

AM69x Processors, Silicon Revision 1.0

1 Features

Processor cores:

- Up to eight 64-bit Arm® Cortex®-A72 microprocessor subsystem at up to 2GHz
 - 2MB shared L2 cache per quad-core Cortex®-A72 cluster
 - 32KB L1 D-Cache and 48KB L1 I-Cache per Cortex®-A72 core
- Up to Four Deep Learning Accelerators:
 - Each with up to 8 Trillion Operations Per Second (TOPS)
 - Total of 32 Trillion Operations Per Second (32TOPS)
- Dual-core Arm® Cortex®-R5F MCUs at up to 1.0GHz in General Compute partition with FFI
 - 16KB L1 D-Cache, 16KB L1 I-Cache, and 64KB L2 TCM
- Dual-core Arm® Cortex®-R5F MCUs at up to 1.0GHz to support Device Management
 - 32K L1 D-Cache, 32K I-Cache, and 64K L2 TCM with SECDED ECC on all memories
- Up to two Vision Processing Accelerators (VPAC) with Image Signal Processor (ISP) and multiple vision assist accelerators
 - 480MPixel/s ISP
 - Support for up to 16-bit input RAW format
 - Wide Dynamic Range (WDR), Lens Distortion Correction (LDC), Vision Imaging Subsystem (VISS), and Multi-Scalar (MSC) support
 - Output color format : 8-bits, 12-bits, and YUV 4:2:2, YUV 4:2:0, RGB, HSV/HSL
- **Multimedia:**
 - Display subsystem supports:
 - Up to 4 displays
 - Up to two DSI 4L TX (up to 2.5K)
 - One eDP 4L
 - One DPI 24-bit RGB parallel interface
 - Safety features such as freeze frame detection and MISR data check
 - 3D Graphics Processing Unit
 - IMG BXS-4-64, up to 800MHz
 - 50GFLOPS, 4GTexels/s
 - Support for APIs OpenGL ES 3.1, Vulkan 1.2
 - Three CSI2.0 4L Camera Serial interface RX (CSI-RX) plus two CSI2.0 4L TX (CSI-TX) with DPHY
 - MIPI CSI 1.3 Compliant + MIPI-DPHY 1.2

- Support for 1,2,3, or 4 data lane mode up to 2.5Gbps
- ECC verification/correction with CRC check + ECC on RAM
- Virtual Channel support (up to 16)
- Ability to write stream data directly to DDR via DMA
- Two Video Encoder/Decoder Modules
 - Support for HEVC (H.265) Main profiles at Level 5.1 High-tier
 - Support for H.264 BaseLine/Main/High Profiles at Level 5.2
 - Support for up to 4K UHD resolution (3840 × 2160) per module
 - Each module supports 4K60 H.264/H.265 Encode/Decode (up to 480MP/s)

Memory subsystem:

- Up to 8MB of on-chip L3 RAM with ECC and coherency
 - ECC error protection
 - Shared coherent cache
 - Supports internal DMA engine
- Up to Four External Memory Interface (EMIF) module with ECC
 - Supports LPDDR4 memory types
 - Supports speeds up to 4266MT/s
 - Up to 4x32-b bus with inline ECC up to 68GB/s
- General-Purpose Memory Controller (GPMC)
- 512KB on-chip SRAM in MAIN domain, protected by ECC
- AEC-Q100 qualified on part number variants ending in Q1

Device security:

- Secure boot with secure run-time support
- Customer programmable root key, up to RSA-4K or ECC-512
- Embedded hardware security module
- Crypto hardware accelerators – PKA with ECC, AES, SHA, RNG, DES and 3DES

High speed serial interfaces:

- Integrated Ethernet switch supporting up to 8 external ports
 - Two ports support 5Gb, 10Gb USXGMII or 5Gb XFI
 - All ports support 1Gb, 2.5Gb SGMII
 - All ports can support QSGMII. A maximum of 2 QSGMII can be enabled and uses all 8 internal lanes. 1 QSGMII interfaces uses 4 internal lanes.



- Up to 4x2-L/2x4L PCI-Express® (PCIe) Gen3 controllers
 - Gen1 (2.5GT/s), Gen2 (5.0GT/s), and Gen3 (8.0GT/s) operation with auto-negotiation
- One USB 3.0 dual-role device (DRD) subsystem
 - Enhanced SuperSpeed Gen1 Port
 - Supports Type-C switching
 - Independently configurable as USB host, USB peripheral, or USB DRD
- One Secure Digital® 3.0 / Secure Digital Input Output 3.0 interfaces (SD3.0/SDIO3.0)
- Universal Flash Storage (UFS 2.1) interface with two lanes
- Two independent flash interfaces configured as
 - One OSPI or HyperBus™ or QSPI flash interfaces, and
 - One QSPI flash interface

System-on-Chip (SoC) architecture:

- Two RGMII/RMII interfaces
- **Ethernet**
- **Automotive interfaces:**
 - Twenty Modular Controller Area Network (MCAN) modules with full CAN-FD support
- **Audio interfaces:**
 - Five Multichannel Audio Serial Port (MCASP) modules
- **Flash memory interfaces:**
 - Embedded MultiMediaCard Interface (eMMC™ 5.1)

TPS6594-Q1 Companion Power Management ICs (PMIC):

- Functional Safety support up to ASIL-D
- Flexible mapping to support different use cases

2 Applications

- Industrial:
 - Machine Vision Camera and computers
 - Smart shopping cart
 - Retail automation
 - Smart agriculture
 - Video surveillance
 - Traffic monitoring
 - Autonomous Mobile Robots (AMR)
 - Drone
 - Industrial transport
 - Industrial Human Machine Interfaces (HMI)
 - Industrial PC
 - Single board computers
 - Patient monitoring and medical devices

3 Description

The AM69, AM69A scalable processor family is based on the evolutionary Jacinto™ 7 architecture, targeted at Smart Vision Camera applications and built on extensive market knowledge accumulated over a decade of TI's leadership in the Vision processor market. The AM69x family is built for a broad set of cost-sensitive high-performance compute applications in Factory Automation, Building Automation, and other markets.

The AM69, AM69A provides high performance compute technology for both traditional and deep learning algorithms at industry leading power/performance ratios with a high level of system integration to enable scalability and lower costs for advanced vision camera applications. Key cores include the latest Arm and GPU processors for general compute, next generation DSP with scalar and vector cores, dedicated deep learning and traditional algorithm accelerators, an integrated next generation imaging subsystem (ISP), video codec, and isolated MCU island. All protected by industrial-grade safety and security hardware accelerators.

General Compute Cores and Integration Overview: Two quad-core cluster configurations (8 cores total) of Arm® Cortex®-A72 facilitate multi-OS applications with minimal need for a software hypervisor. Up to two Dual-core (4 cores total) Arm® Cortex®-R5F subsystems enable low-level, timing critical processing tasks to leave the Arm® Cortex®-A72 core's unencumbered for applications. Building on the existing world-class ISP, TI's 7th generation ISP includes flexibility to process a broader sensor suite, support for higher bit depth, and features targeting analytics applications. Integrated diagnostics and safety features support operations up to SIL-2 levels while the integrated security features protect data against modern day attacks. CSI2.0 ports enable multi sensor inputs.

Key Performance Cores Overview: The C7000™ DSP next generation core ("C7x") combines TI's industry leading DSP and EVE cores into a single higher performance core and adds floating-point vector calculation capabilities, enabling backward compatibility for legacy code while simplifying software programming. Four "MMAv2" deep learning accelerators enable performance up to 32 Trillion Operations Per Second (TOPS) [8TOPS per core] within the lowest power envelope in the industry, even when operating even at the worst case junction temperatures of 105°C and 125°C. The dedicated Vision hardware accelerators provide vision pre-processing with no impact on system performance. The C7x/MMA cores are available only for deep-learning function in the AM69, AM69A class of processors.

Package Information

PART NUMBER	PACKAGE ⁽¹⁾	PACKAGE SIZE ⁽²⁾
XAM69A94	AND (FCBGA, 1063)	27mm x 27mm
XAM6954	AND (FCBGA, 1063)	27mm x 27mm
AM69x	ALY (FCBGA, 1414)	31mm x 31mm
XJ784S4	ALY (FCBGA, 1414)	31mm x 31mm

- (1) For more information, see the [Mechanical, Packaging, and Orderable Information](#) section.
(2) The package size (length × width) is a nominal value and includes pins, where applicable.

3.1 Functional Block Diagram

Figure 3-1 is functional block diagram for the device.

Note

To understand what device features are currently supported by TI Software Development Kits (SDKs), see the [AM69 Software Build Sheet \(PROCESSOR-SDK-AM69\)](#) and [AM69A Software Build Sheet \(PROCESSOR-SDK-AM69A\)](#).

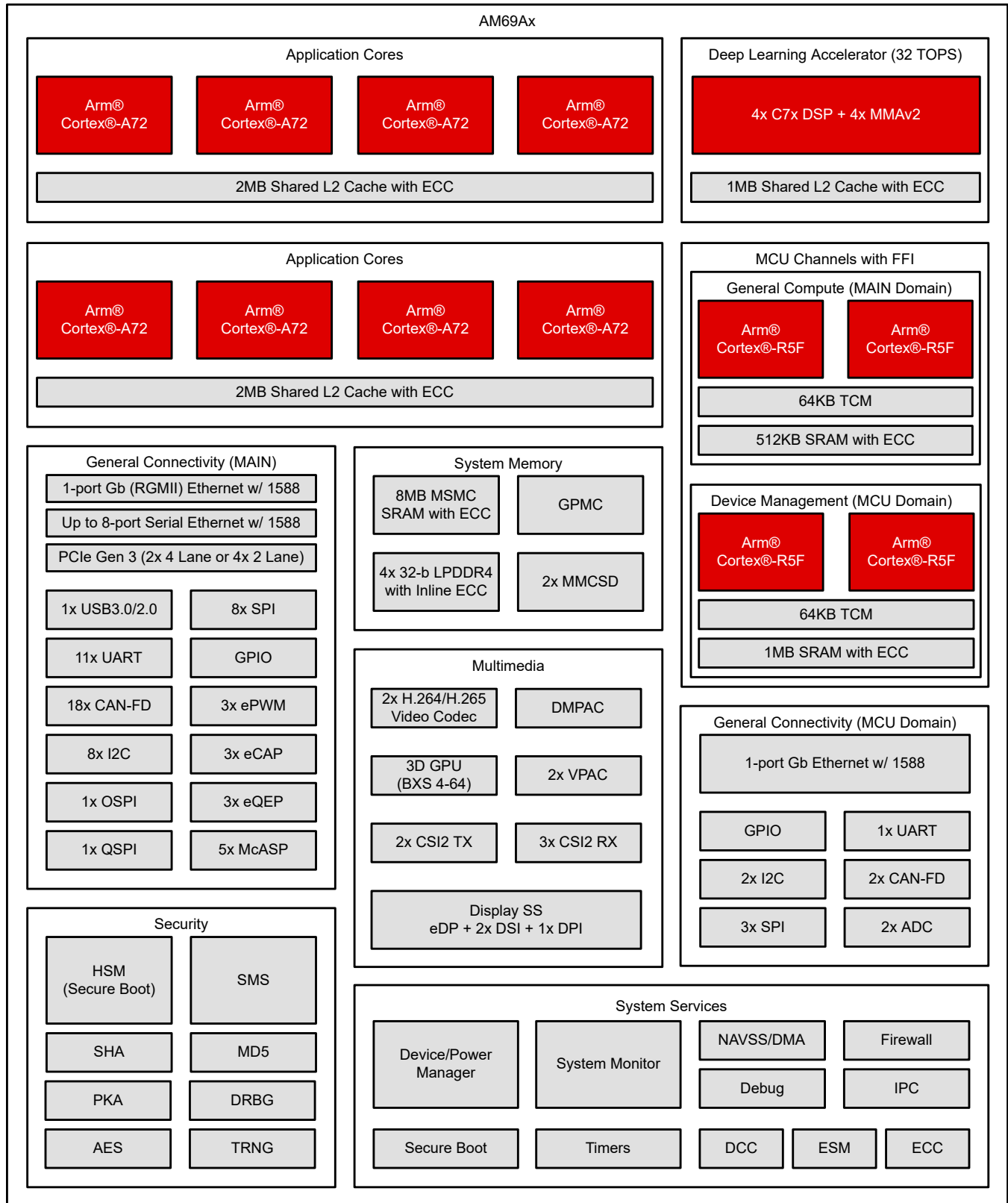

Figure 3-1. Functional Block Diagram

Table of Contents

1 Features	1	9 Device Connection and Layout Fundamentals	290
2 Applications	2	9.1 Power Supply Decoupling and Bulk Capacitors.....	290
3 Description	3	9.2 External Oscillator.....	290
3.1 Functional Block Diagram.....	3	9.3 JTAG and EMU.....	290
4 Device Comparison	6	9.4 Reset.....	290
5 Terminal Configuration and Functions	9	9.5 Unused Pins.....	290
5.1 Pin Diagrams.....	9	9.6 Hardware Design Guide for Jacinto™ 7 Devices...	290
5.2 Pin Attributes.....	10	10 Peripheral- and Interface-Specific Design	
5.3 Signal Descriptions.....	91	Information	291
5.4 Pin Connectivity Requirements.....	137	10.1 LPDDR4 Board Design and Layout Guidelines...	291
6 Specifications	142	10.2 OSPI and QSPI Board Design and Layout	
6.1 Absolute Maximum Ratings.....	142	Guidelines.....	291
6.2 ESD Ratings.....	143	10.3 USB VBUS Design Guidelines.....	294
6.3 Power-On-Hour (POH) Limits.....	144	10.4 System Power Supply Monitor Design	
6.4 Recommended Operating Conditions.....	144	Guidelines using VMON/POK.....	295
6.5 Operating Performance Points.....	146	10.5 High Speed Differential Signal Routing Guidance	296
6.6 Electrical Characteristics.....	147	10.6 Thermal Solution Guidance.....	297
6.7 VPP Specifications for One-Time Programmable		11 Device and Documentation Support	298
(OTP) eFuses.....	153	11.1 Device Nomenclature.....	298
6.8 Thermal Resistance Characteristics.....	155	11.2 Tools and Software.....	301
6.9 Temperature Sensor Characteristics.....	157	11.3 Support Resources.....	301
6.10 Timing and Switching Characteristics.....	158	11.4 Trademarks.....	301
7 Detailed Description	276	11.5 Electrostatic Discharge Caution.....	301
7.1 Overview.....	276	11.6 Glossary.....	301
7.2 Functional Block Diagram.....	276	12 Revision History	301
7.3 Processor Subsystems.....	278	13 Mechanical, Packaging, and Orderable	
7.4 Accelerators and Coprocessors.....	279	Information	303
7.5 Other Subsystems.....	280	13.1 Packaging Information.....	303
8 Applications, Implementation, and Layout	289		

4 Device Comparison

Table 4-1 shows the features of the SoC.

Note

To understand what device features are currently supported by TI Software Development Kits (SDKs), see the [AM69 Software Build Sheet \(PROCESSOR-SDK-AM69\)](#) and [AM69A Software Build Sheet \(PROCESSOR-SDK-AM69A\)](#).

Table 4-1. Device Comparison

FEATURES ⁽⁹⁾	REFERENCE NAME	AM69A98	AM69A94	AM69A78	AM6958	AM6954
MECHANICAL PACKAGES						
ALY (FCBGA, 1414)	31mm x 31mm	Yes	–	Yes	Yes	–
AND (FCBGA, 1063)	27mm x 27mm	–	Yes	–	–	Yes
PROCESSORS AND ACCELERATORS						
Speed Grades		T				
Arm Cortex-A72 Microprocessor Subsystem	Arm A72	Octal Core	Quad Core ⁽¹⁴⁾	Octal Core	Octal Core	Quad Core ⁽¹⁴⁾
Arm Cortex-R5F	Arm R5F Device Management	Dual Core ⁽¹¹⁾				
	Arm R5F General Compute	Dual Core ⁽¹¹⁾				
Security Management Subsystem	SMS	Yes				
Security Accelerators	SA	Yes				
Deep Learning Accelerator (32 TOPS)	C7x DSP + MMA	Quad Core ⁽¹²⁾	3 C7x DSP + 2 MMA ⁽¹²⁾	Quad Core ⁽¹²⁾	No	
Graphics Accelerator IMG BXS-4-64	GPU	Yes		No	Yes	
Depth and Motion Processing Accelerators	DMPAC	Yes			No	
Vision Processing Accelerators	VPAC	Yes			No	
Video Encoder/Decoder	VENC/VDEC	2 × Encode/Decode	1 × Encode/Decode	2 × Encode/Decode		1 × Encode/Decode
SAFETY AND SECURITY						
Safety Targeted	Safety	No ⁽¹⁾				
Device Security	Security	Optional ⁽²⁾				
AEC-Q100 Qualified	Q1	Optional ⁽³⁾				
PROGRAM AND DATA STORAGE						
On-Chip Shared Memory (RAM) in MAIN Domain	OCSRAM	512KB SRAM				
On-Chip Shared Memory (RAM) in MCU Domain	MCU_MSRAM	1MB SRAM				
Multicore Shared Memory Controller	MSMC	8MB (On-Chip SRAM with ECC)	4MB (On-Chip SRAM with ECC)	8MB (On-Chip SRAM with ECC)		4MB (On-Chip SRAM with ECC)
LPDDR4 DDR Subsystem	DDRSS0 ⁽⁵⁾	Up to 8GB (32-bit data) with inline ECC				
	DDRSS1 ⁽⁵⁾	Up to 8GB (32-bit data) with inline ECC				
	DDRSS2 ^{(4) (5)}	Up to 8GB (32-bit data) with inline ECC	No	Up to 8GB (32-bit data) with inline ECC		No
	DDRSS3 ^{(4) (5)}	Up to 8GB (32-bit data) with inline ECC	No	Up to 8GB (32-bit data) with inline ECC		No
	SECEDED	Yes				
General-Purpose Memory Controller	GPMC	Up to 1GB with ECC				

Table 4-1. Device Comparison (continued)

FEATURES ⁽⁹⁾	REFERENCE NAME	AM69A98	AM69A94	AM69A78	AM6958	AM6954
PERIPHERALS						
Display Subsystem	DSS			Yes		
	DSI 4L TX			2		
	eDP 4L			1		
	DPI			1		
Modular Controller Area Network Interface with Full CAN-FD Support	MCAN			20		
General-Purpose I/O	GPIO			155		
Inter-Integrated Circuit Interface	I2C			10		
Improved Inter-Integrated Circuit Interface	I3C			1		
Analog-to-Digital Converter	ADC			2		
Capture Subsystem with Camera Serial Interface (CSI2)	CSI2.0 4L RX			3		
	CSI2.0 4L TX			2		
Multichannel Serial Peripheral Interface	MCSPi			11		
Multichannel Audio Serial Port	MCASP0			16 Serializers		
	MCASP1			5 Serializers		
	MCASP2			5 Serializers		
	MCASP3			3 Serializers		
	MCASP4			5 Serializers		
MultiMedia Card/ Secure Digital Interface	MMCSD0			eMMC (8-bits)		
	MMCSD1			SD/SDIO (4-bits)		
Universal Flash Storage	UFS 2L			No		
Flash Subsystem (FSS)	OSPI0			8-bits ⁽⁸⁾		
	OSPI1 ⁽¹⁰⁾			4-bits		
	HyperBus			Yes ⁽⁸⁾		
4x PCI Express Port with Integrated PHY	PCIE			2x4L or 4x2L ^{(6) (13)}		
Ethernet Interfaces	MCU CPSW2G			RMII or RGMII		
	MAIN CPSW2G			RMII or RGMII		
	CPSW9G	8port SERDES ⁽⁶⁾	4port SERDES ^{(6) (7)}	8port SERDES ⁽⁶⁾		4port SERDES ^{(6) (7)}
General-Purpose Timers	TIMER			30		
Enhanced High Resolution Pulse-Width Modulator Module	eHRPWM			6		
Enhanced Capture Module	eCAP			3		
Enhanced Quadrature Encoder Pulse Module	eQEP			3		
Universal Asynchronous Receiver and Transmitter	UART			12		
Universal Serial Bus (USB3.1) SuperSpeed Dual-Role-Device (DRD) Ports with SS PHY	USB0			Yes ⁽⁶⁾		

- (1) Functional Safety is not supported on this device family, if interested in this feature, please see the [TDA4VH device family](#).
- (2) Device security features including Secure Boot and Customer Programmable Keys are applicable to select part number variants as indicated by the Device Type (Y) identifier in the [Nomenclature Description table](#)
- (3) AEC-Q100 qualification is applicable to select part number variants as indicated by the Automotive Designator (Q1) identifier in the [Nomenclature Description table](#)
- (4) DDRSS2 and DDRSS3 are not available on the 27mm package variant of this SoC. DDR2/DDR3 should be not be used if software compatibility is desired with systems that use the 27mm package
- (5) DDRSS0, DDRSS1, DDRSS2 and DDRSS3 must always be used in incremental order. For instance, when using a single LPDDR component, it must be connected to DDR0_* interface. When using two LPDDR components, they must be connected to DDR0_* and DDR1_* interfaces, and so forth.
- (6) DP, SGMII, USB3.0, and PCIE share a total of 16 SerDes lanes (31mm package) or 12 SerDes lanes (27mm package variant). **SERDES2** is not available on the 27mm package variant of this SoC.
- (7) AM69, AM69A CPSW supports up to 8 ports using the following instances and signals and modes of operation:
 - PORT1 **Signals:** SGMII1, **Modes:** One of 5Gb, 10Gb USXGMII/XFI, 2.5Gb SGMII/XAUI, 1Gb SGMII, 5Gb QSGMII
 - PORT2 **Signals:** SGMII2, **Modes:** One of 5Gb, 10Gb USXGMII/XFI, 2.5Gb SGMII/XAUI, 1Gb SGMII, 5Gb QSGMII
 - PORTn (n=3 thru 8) **Signals:** SGMII n, **Modes:** One of 2.5Gb SGMII/XAUI, 1Gb SGMII, 5Gb QSGMII

If QSGMII is used on any SGMII Port 1 thru 4, then SGMII1/2/3/4 cannot be used for Ethernet functionality since all 4 internal CPSW ports map to the selected QSGMII SERDES port.

If QSGMII is used on any SGMII Port 5 thru 8, then SGMII5/6/7/8 cannot be used for Ethernet functionality since all 4 internal CPSW ports map to the selected QSGMII SERDES port.

AM69A94 (27mm)/AM6954 (27mm) CPSW supports up to 4 ports. To maximize pin muxing flexibility, the system designer can choose based on any available PORTS, but must limit the total number of ports used to four or fewer.

- (8) Two simultaneous flash interfaces configured as OSPI0 and OSPI1, or HyperBus and OSPI1.
- (9) J784S4 is the base part number for the superset device. Software should constrain the features used to match the intended production device.
- (10) OSPI1 module only pins out 4 pins and is referred to as QSPI in some contexts.
- (11) MCU_R5FSS0 includes Dual-Core R5F that provides Device Management functionality, and is reserved for executing TI provided code.
R5FSS1 is a Dual-Core R5F that provides Multimedia Control functionality, and is reserved for executing TI provided code.
- (12) The Deep Learning Accelerator C7x + MMA are reserved for executing TI provided code, and are not available for custom code.
- (13) **AM69A94 (27mm)/AM6954 (27mm)** PCIe supports 1x4L or 2x2L options. To maximize pin muxing flexibility, the system designer can choose any available PCIe instances or available PORTS, but must limit to a maximum of 1x4L or 2x2L.
- (14) The A72SS Quad Core variant provides a single quad core cluster, namely A72SS0_CORE[3:0].

5 Terminal Configuration and Functions

5.1 Pin Diagrams

Note

The terms "ball", "pin", and "terminal" are used interchangeably throughout the document. An attempt is made to use "ball" only when referring to the physical package.

Figure 5-1 shows the ball locations for the 1414-ball flip chip ball grid array (FCBGA) package to quickly locate signal names and ball grid numbering. This figure is used in conjunction with Table 5-1 through Section 5.4 (Pin Attributes table and all Signal Descriptions tables, including the Pin Connectivity Requirements table).

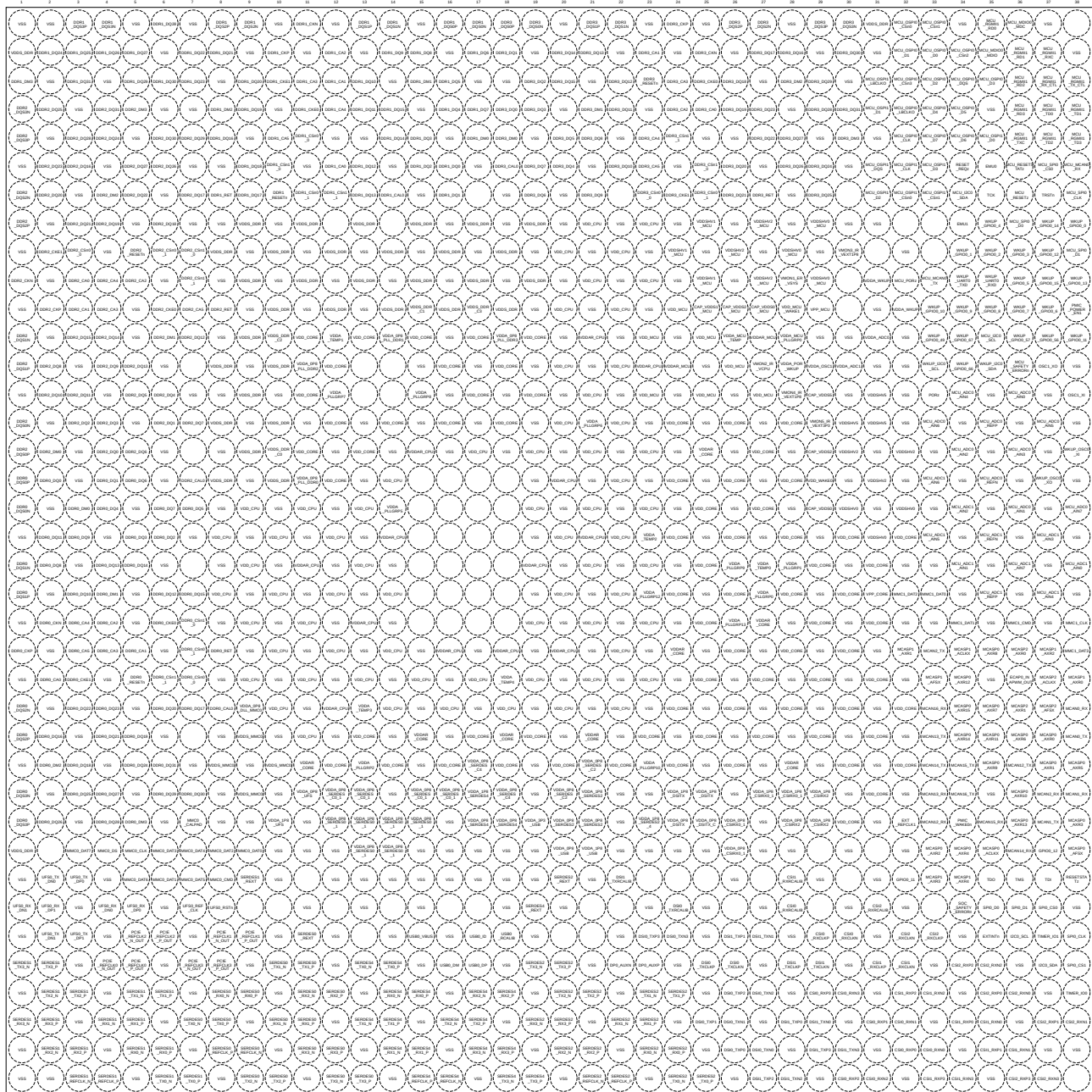

Figure 5-1. ALY FCBGA-N1414 Pin Diagram (Top View)

Figure 5-2 shows the ball locations for the 1063-ball flip chip ball grid array (FCBGA) package to quickly locate signal names and ball grid numbering. This figure is used in conjunction with Table 5-1 through Section 5.4 (Pin Attributes table and all Signal Descriptions tables, including the Pin Connectivity Requirements table).

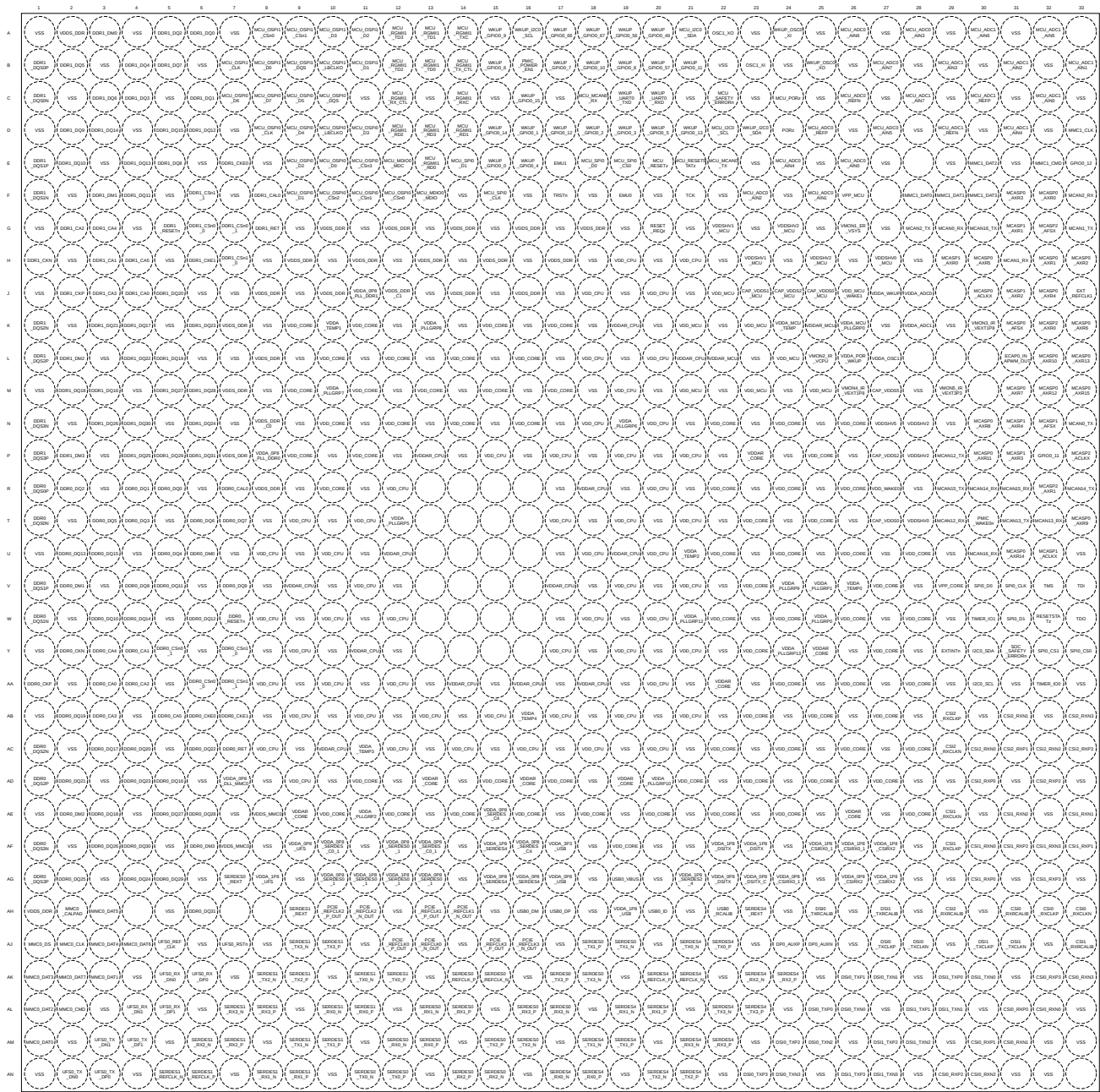

Figure 5-2. AND FCBGA-N1063 Pin Diagram (Top View)

5.2 Pin Attributes

- Ball Number:** Ball numbers assigned to each terminal of the Ball Grid Array package.
- Ball Name:** Ball name assigned to each terminal of the Ball Grid Array package (this name is typically taken from the primary MUXMODE 0 signal function).
- Signal Name:** Signal name of all dedicated and pin multiplexed signal functions associated with a ball.

Note

The *Pin Attributes* table, defines the SoC pin multiplexed signal function implemented at the pin and **does not** define secondary multiplexing of signal functions implemented in device subsystems. Secondary multiplexing of signal functions are not described in this table. For more information on secondary multiplexed signal functions, see the respective peripheral chapter of the device TRM.

4. **Mux Mode:** The MUXMODE value associated with each pin multiplexed signal function:
- MUXMODE 0 is the primary pin multiplexed signal function. However, the primary pin multiplexed signal function is not necessarily the default pin multiplexed signal function.
 - MUXMODE values 1 through 15 are possible for pin multiplexed signal functions. However, not all MUXMODE values have been implemented. The only valid MUXMODE values are those defined as pin multiplexed signal functions within the Pin Attributes table. Only valid values of MUXMODE can be used.
 - Bootstrap defines SOC configuration pins, where the logic state applied to each pin is latched on the rising edge of PORz_OUT. These input signal functions are fixed to their respective pins and are not programmable via MUXMODE.
 - An empty box or "-" means Not Applicable.

Note

- The value found in the MUX MODE AFTER RESET column defines the default pin multiplexed signal function selected when MCU_PORz is deasserted.
- Configuring two pins to the same pin multiplexed signal function can yield unexpected results and is not supported. This can be prevented with proper software configuration.
- Configuring a pad to an undefined multiplexing mode results in undefined behavior and must be avoided.

5. **Signal Type:** Signal type and direction:
- I = Input
 - O = Output
 - OD = Output, with open-drain output function
 - IO = Input, Output, or simultaneously Input and Output
 - IOD = Input, Output, or simultaneously Input and Output, with open-drain output function
 - IOZ = Input, Output, or simultaneously Input and Output, with three-state output function
 - OZ = Output with three-state output function
 - A = Analog
 - CAP = LDO capacitor
 - PWR = Power
 - GND = Ground
6. **I/O VOLTAGE VALUE:** This column describes the IO voltage value (the corresponding power supply). An empty box means Not Applicable.
7. **Ball State During Reset (RX/TX/PULL):** State of the terminal while MCU_PORz is asserted, where RX defines the state of the input buffer, TX defines the state of the output buffer, and PULL defines the state of internal pull resistors:
- RX (Input buffer)
 - Off: The input buffer is **disabled**.
 - On: The input buffer is **enabled**.
 - TX (Output buffer)
 - Off: The output buffer is **disabled**.
 - Low: The output buffer is **enabled** and drives V_{OL} .
 - High: The output buffer is **enabled** and drives V_{OH} .
 - PULL (Internal pull resistors)
 - Off: Internal pull resistors are turned **off**.
 - Up: Internal **pull-up** resistor is turned on.

- Down: Internal **pull-down** resistor is turned on.
 - NA: No internal pull resistor.
 - An empty box, or "-" means Not Applicable.
8. **Ball State After Reset (RX/TX/PULL):** State of the terminal after MCU_PORz is deasserted, where RX defines the state of the input buffer, TX defines the state of the output buffer, and PULL defines the state of internal pull resistors:
- RX (Input buffer)
 - Off: The input buffer is **disabled**.
 - On: The input buffer is **enabled**.
 - TX (Output buffer)
 - Off: The output buffer is **disabled**.
 - SS: The subsystem selected with MUXMODE determines the output buffer state.
 - PULL (Internal pull resistors)
 - Off: Internal pull resistors are turned **off**.
 - Up: Internal **pull-up resistor** is turned on.
 - Down: Internal **pull-down resistor** is turned on.
 - NA: No internal pull resistor.
 - An empty box, NA, or "-" means Not Applicable.
9. **Mux Mode After Reset:** The value found in this column defines the **default** pin multiplexed signal function after MCU_PORz is deasserted.
- An empty box, NA, or "-" means Not Applicable.
10. **PULL TYPE:** Indicates the presence of an internal pullup or pulldown resistor. Pullup and pulldown resistors can be enabled or disabled via software.
- PU: Internal pull-up Only
 - PD: Internal pull-down Only
 - PU/PD: Internal pull-up and pull-down
 - An empty box, NA, or "-" means No internal pull.

Note

Configuring two pins to the same pin multiplexed signal function is not supported as this yields unexpected results. Issues can be easily prevented with the proper software configuration.

When a pad is set into a multiplexing mode which is not defined by pin multiplexing, that pad's behavior is undefined. This must be avoided.

11. **Power:** The power supply of the associated I/O, when applicable.
- An empty box, NA, or "-" means Not Applicable.
12. **Hys:** Indicates if the input buffer associated with this I/O has hysteresis:
- Yes: Hysteresis Support
 - No: **No** Hysteresis Support
 - An empty box, NA, or "-" means Not Applicable.
- For more information, see the hysteresis values in [Electrical Characteristics](#) section.
13. **Voltage Buffer Type:** This column defines the buffer type associated with a terminal. This information can be used to determine the applicable Electrical Characteristics table.
- An empty box, NA, or "-" means Not Applicable.
- For electrical characteristics, refer to the appropriate buffer type table in [Electrical Characteristics](#) section.
14. **IO RET:** Yes means WKUP and IO retention supported.
15. **Pad Configuration Register Name:** This is the name of the device pad/pin configuration register.

- 16. Pad Configuration Register Address:** This is the memory address of the device pad/pin configuration register.

Table 5-1. Pin Attributes (ALY, AND Packages)

ALY Ball Num [1]	AND Ball Num [1]	Ball Name [2] PADCFG Register [15] PADCFG Address [16]	Signal Name [3]	Mux Mode [4]	Signal Type [5]	I/O Voltage [6]	Ball State DURING Reset (RX/TX/PULL) [7]	Ball State AFTER Reset (RX/TX/PULL) [8]	Mux Mode AFTER Reset [9]	Pull Type [10]	Power [11]	Hys [12]	Voltage Buffer Type [13]	IO RET [14]
V29	T27	CAP_VDDS0	CAP_VDDS0		CAP									
L27	J25	CAP_VDDS0_MCU	CAP_VDDS0_MCU		CAP									
L25	J23	CAP_VDDS1_MCU	CAP_VDDS1_MCU		CAP									
T29	P27	CAP_VDDS2	CAP_VDDS2		CAP									
L26	J24	CAP_VDDS2_MCU	CAP_VDDS2_MCU		CAP									
P29	M27	CAP_VDDS5	CAP_VDDS5		CAP									
AN30	AH33	CSI0_RXCLKN	CSI0_RXCLKN		I	1.8 V					VDDA_0P8_ CSIRX0_1 / VDDA_1P8_ CSIRX0_1		D-PHY	
AN29	AH32	CSI0_RXCLKP	CSI0_RXCLKP		I	1.8 V					VDDA_0P8_ CSIRX0_1 / VDDA_1P8_ CSIRX0_1		D-PHY	
AM28	AH31	CSI0_RXRCALIB	CSI0_RXRCALIB		A	1.8 V					VDDA_0P8_ CSIRX0_1 / VDDA_1P8_ CSIRX0_1		D-PHY	
AP32	AE29	CSI1_RXCLKN	CSI1_RXCLKN		I	1.8 V					VDDA_0P8_ CSIRX0_1 / VDDA_1P8_ CSIRX0_1		D-PHY	
AP31	AF29	CSI1_RXCLKP	CSI1_RXCLKP		I	1.8 V					VDDA_0P8_ CSIRX0_1 / VDDA_1P8_ CSIRX0_1		D-PHY	
AL28	AJ33	CSI1_RXRCALIB	CSI1_RXRCALIB		A	1.8 V					VDDA_0P8_ CSIRX0_1 / VDDA_1P8_ CSIRX0_1		D-PHY	
AN32	AC29	CSI2_RXCLKN	CSI2_RXCLKN		I	1.8 V					VDDA_0P8_ CSIRX2 / VDDA_1P8_ CSIRX2		D-PHY	
AN33	AB29	CSI2_RXCLKP	CSI2_RXCLKP		I	1.8 V					VDDA_0P8_ CSIRX2 / VDDA_1P8_ CSIRX2		D-PHY	
AM31	AH29	CSI2_RXRCALIB	CSI2_RXRCALIB		A	1.8 V					VDDA_0P8_ CSIRX2 / VDDA_1P8_ CSIRX2		D-PHY	
AU33	AL32	CSI0_RXN0	CSI0_RXN0		I	1.8 V					VDDA_0P8_ CSIRX0_1 / VDDA_1P8_ CSIRX0_1		D-PHY	

Table 5-1. Pin Attributes (ALY, AND Packages) (continued)

ALY Ball Num [1]	AND Ball Num [1]	Ball Name [2] PADCFG Register [15] PADCFG Address [16]	Signal Name [3]	Mux Mode [4]	Signal Type [5]	I/O Voltage [6]	Ball State DURING Reset (RX/TX/PULL) [7]	Ball State AFTER Reset (RX/TX/PULL) [8]	Mux Mode AFTER Reset [9]	Pull Type [10]	Power [11]	Hys [12]	Voltage Buffer Type [13]	IO RET [14]
AT32	AM31	CSI0_RXN1	CSI0_RXN1		I	1.8 V					VDDA_0P8_CSIRX0_1 / VDDA_1P8_CSIRX0_1		D-PHY	
AV31	AN30	CSI0_RXN2	CSI0_RXN2		I	1.8 V					VDDA_0P8_CSIRX0_1 / VDDA_1P8_CSIRX0_1		D-PHY	
AR30	AK33	CSI0_RXN3	CSI0_RXN3		I	1.8 V					VDDA_0P8_CSIRX0_1 / VDDA_1P8_CSIRX0_1		D-PHY	
AU32	AL31	CSI0_RXP0	CSI0_RXP0		I	1.8 V					VDDA_0P8_CSIRX0_1 / VDDA_1P8_CSIRX0_1		D-PHY	
AT31	AM30	CSI0_RXP1	CSI0_RXP1		I	1.8 V					VDDA_0P8_CSIRX0_1 / VDDA_1P8_CSIRX0_1		D-PHY	
AV30	AN29	CSI0_RXP2	CSI0_RXP2		I	1.8 V					VDDA_0P8_CSIRX0_1 / VDDA_1P8_CSIRX0_1		D-PHY	
AR29	AK32	CSI0_RXP3	CSI0_RXP3		I	1.8 V					VDDA_0P8_CSIRX0_1 / VDDA_1P8_CSIRX0_1		D-PHY	
AT35	AF30	CSI1_RXN0	CSI1_RXN0		I	1.8 V					VDDA_0P8_CSIRX0_1 / VDDA_1P8_CSIRX0_1		D-PHY	
AU36	AE33	CSI1_RXN1	CSI1_RXN1		I	1.8 V					VDDA_0P8_CSIRX0_1 / VDDA_1P8_CSIRX0_1		D-PHY	
AR33	AE31	CSI1_RXN2	CSI1_RXN2		I	1.8 V					VDDA_0P8_CSIRX0_1 / VDDA_1P8_CSIRX0_1		D-PHY	
AV34	AF32	CSI1_RXN3	CSI1_RXN3		I	1.8 V					VDDA_0P8_CSIRX0_1 / VDDA_1P8_CSIRX0_1		D-PHY	
AT34	AG30	CSI1_RXP0	CSI1_RXP0		I	1.8 V					VDDA_0P8_CSIRX0_1 / VDDA_1P8_CSIRX0_1		D-PHY	

Table 5-1. Pin Attributes (ALY, AND Packages) (continued)

ALY Ball Num [1]	AND Ball Num [1]	Ball Name [2] PADCFG Register [15] PADCFG Address [16]	Signal Name [3]	Mux Mode [4]	Signal Type [5]	I/O Voltage [6]	Ball State DURING Reset (RX/TX/PULL) [7]	Ball State AFTER Reset (RX/TX/PULL) [8]	Mux Mode AFTER Reset [9]	Pull Type [10]	Power [11]	Hys [12]	Voltage Buffer Type [13]	IO RET [14]
AU35	AF33	CSI1_RXP1	CSI1_RXP1		I	1.8 V					VDDA_0P8_CSIRX0_1 / VDDA_1P8_CSIRX0_1		D-PHY	
AR32	AF31	CSI1_RXP2	CSI1_RXP2		I	1.8 V					VDDA_0P8_CSIRX0_1 / VDDA_1P8_CSIRX0_1		D-PHY	
AV33	AG32	CSI1_RXP3	CSI1_RXP3		I	1.8 V					VDDA_0P8_CSIRX0_1 / VDDA_1P8_CSIRX0_1		D-PHY	
AR36	AC30	CSI2_RXN0	CSI2_RXN0		I	1.8 V					VDDA_0P8_CSIRX2 / VDDA_1P8_CSIRX2		D-PHY	
AT38	AB31	CSI2_RXN1	CSI2_RXN1		I	1.8 V					VDDA_0P8_CSIRX2 / VDDA_1P8_CSIRX2		D-PHY	
AP35	AC32	CSI2_RXN2	CSI2_RXN2		I	1.8 V					VDDA_0P8_CSIRX2 / VDDA_1P8_CSIRX2		D-PHY	
AV37	AB33	CSI2_RXN3	CSI2_RXN3		I	1.8 V					VDDA_0P8_CSIRX2 / VDDA_1P8_CSIRX2		D-PHY	
AR35	AD30	CSI2_RXP0	CSI2_RXP0		I	1.8 V					VDDA_0P8_CSIRX2 / VDDA_1P8_CSIRX2		D-PHY	
AT37	AC31	CSI2_RXP1	CSI2_RXP1		I	1.8 V					VDDA_0P8_CSIRX2 / VDDA_1P8_CSIRX2		D-PHY	
AP34	AD32	CSI2_RXP2	CSI2_RXP2		I	1.8 V					VDDA_0P8_CSIRX2 / VDDA_1P8_CSIRX2		D-PHY	
AV36	AC33	CSI2_RXP3	CSI2_RXP3		I	1.8 V					VDDA_0P8_CSIRX2 / VDDA_1P8_CSIRX2		D-PHY	
AB2	Y2	DDR0_CKN	DDR0_CKN		IO	1.1 V					VDDS_DDR / VDDS_DDR_C0		DDR	
AC1	AA1	DDR0_CKP	DDR0_CKP		IO	1.1 V					VDDS_DDR / VDDS_DDR_C0		DDR	

Table 5-1. Pin Attributes (ALY, AND Packages) (continued)

ALY Ball Num [1]	AND Ball Num [1]	Ball Name [2] PADCFG Register [15] PADCFG Address [16]	Signal Name [3]	Mux Mode [4]	Signal Type [5]	I/O Voltage [6]	Ball State DURING Reset (RX/TX/PULL) [7]	Ball State AFTER Reset (RX/TX/PULL) [8]	Mux Mode AFTER Reset [9]	Pull Type [10]	Power [11]	Hys [12]	Voltage Buffer Type [13]	IO RET [14]
AD5	W7	DDR0_RESETh	DDR0_RESETh		IO	1.1 V					VDDS_DDR / VDDS_DDR_C0		DDR	
AC8	AC7	DDR0_RET	DDR0_RET		I	1.1 V					VDDS_DDR / VDDS_DDR_C0		DDR	
A11	H1	DDR1_CKN	DDR1_CKN		IO	1.1 V					VDDS_DDR / VDDS_DDR_C1		DDR	
B10	J2	DDR1_CKP	DDR1_CKP		IO	1.1 V					VDDS_DDR / VDDS_DDR_C1		DDR	
G10	G5	DDR1_RESETh	DDR1_RESETh		IO	1.1 V					VDDS_DDR / VDDS_DDR_C1		DDR	
G8	G8	DDR1_RET	DDR1_RET		I	1.1 V					VDDS_DDR / VDDS_DDR_C1		DDR	
K1		DDR2_CKN	DDR2_CKN		IO	1.1 V					VDDS_DDR / VDDS_DDR_C2		DDR	
L2		DDR2_CKP	DDR2_CKP		IO	1.1 V					VDDS_DDR / VDDS_DDR_C2		DDR	
J5		DDR2_RESETh	DDR2_RESETh		IO	1.1 V					VDDS_DDR / VDDS_DDR_C2		DDR	
L8		DDR2_RET	DDR2_RET		I	1.1 V					VDDS_DDR / VDDS_DDR_C2		DDR	
B25		DDR3_CKN	DDR3_CKN		IO	1.1 V					VDDS_DDR / VDDS_DDR_C3		DDR	
A24		DDR3_CKP	DDR3_CKP		IO	1.1 V					VDDS_DDR / VDDS_DDR_C3		DDR	
C23		DDR3_RESETh	DDR3_RESETh		IO	1.1 V					VDDS_DDR / VDDS_DDR_C3		DDR	
G27		DDR3_RET	DDR3_RET		I	1.1 V					VDDS_DDR / VDDS_DDR_C3		DDR	
AD2	AA3	DDR0_CA0	DDR0_CA0		IO	1.1 V					VDDS_DDR / VDDS_DDR_C0		DDR	
AC5	Y4	DDR0_CA1	DDR0_CA1		IO	1.1 V					VDDS_DDR / VDDS_DDR_C0		DDR	

Table 5-1. Pin Attributes (ALY, AND Packages) (continued)

ALY Ball Num [1]	AND Ball Num [1]	Ball Name [2] PADCFG Register [15] PADCFG Address [16]	Signal Name [3]	Mux Mode [4]	Signal Type [5]	I/O Voltage [6]	Ball State DURING Reset (RX/TX/PULL) [7]	Ball State AFTER Reset (RX/TX/PULL) [8]	Mux Mode AFTER Reset [9]	Pull Type [10]	Power [11]	Hys [12]	Voltage Buffer Type [13]	IO RET [14]
AB4	AA4	DDR0_CA2	DDR0_CA2		IO	1.1 V					VDDS_DDR / VDDS_DDR_C0		DDR	
AC4	AB3	DDR0_CA3	DDR0_CA3		IO	1.1 V					VDDS_DDR / VDDS_DDR_C0		DDR	
AB3	Y3	DDR0_CA4	DDR0_CA4		IO	1.1 V					VDDS_DDR / VDDS_DDR_C0		DDR	
AC3	AB5	DDR0_CA5	DDR0_CA5		IO	1.1 V					VDDS_DDR / VDDS_DDR_C0		DDR	
AE8	R7	DDR0_CAL0	DDR0_CAL0		A	1.1 V					VDDS_DDR / VDDS_DDR_C0		DDR	
AB6	AB6	DDR0_CKE0	DDR0_CKE0		IO	1.1 V					VDDS_DDR / VDDS_DDR_C0		DDR	
AD3	AB7	DDR0_CKE1	DDR0_CKE1		IO	1.1 V					VDDS_DDR / VDDS_DDR_C0		DDR	
AD7	AA6	DDR0_CSn0_0	DDR0_CSn0_0		IO	1.1 V					VDDS_DDR / VDDS_DDR_C0		DDR	
AC7	Y5	DDR0_CSn0_1	DDR0_CSn0_1		IO	1.1 V					VDDS_DDR / VDDS_DDR_C0		DDR	
AB7	Y7	DDR0_CSn1_0	DDR0_CSn1_0		IO	1.1 V					VDDS_DDR / VDDS_DDR_C0		DDR	
AD6	AA7	DDR0_CSn1_1	DDR0_CSn1_1		IO	1.1 V					VDDS_DDR / VDDS_DDR_C0		DDR	
V3	U6	DDR0_DM0	DDR0_DM0		IO	1.1 V					VDDS_DDR / VDDS_DDR_C0		DDR	
AA4	V2	DDR0_DM1	DDR0_DM1		IO	1.1 V					VDDS_DDR / VDDS_DDR_C0		DDR	
AG2	AE2	DDR0_DM2	DDR0_DM2		IO	1.1 V					VDDS_DDR / VDDS_DDR_C0		DDR	
AJ5	AF6	DDR0_DM3	DDR0_DM3		IO	1.1 V					VDDS_DDR / VDDS_DDR_C0		DDR	
U2	R5	DDR0_DQ0	DDR0_DQ0		IO	1.1 V					VDDS_DDR / VDDS_DDR_C0		DDR	

Table 5-1. Pin Attributes (ALY, AND Packages) (continued)

ALY Ball Num [1]	AND Ball Num [1]	Ball Name [2] PADCFG Register [15] PADCFG Address [16]	Signal Name [3]	Mux Mode [4]	Signal Type [5]	I/O Voltage [6]	Ball State DURING Reset (RX/TX/PULL) [7]	Ball State AFTER Reset (RX/TX/PULL) [8]	Mux Mode AFTER Reset [9]	Pull Type [10]	Power [11]	Hys [12]	Voltage Buffer Type [13]	IO RET [14]
U4	R4	DDR0_DQ1	DDR0_DQ1		IO	1.1 V					VDDS_DDR / VDDS_DDR_C0		DDR	
W6	R2	DDR0_DQ2	DDR0_DQ2		IO	1.1 V					VDDS_DDR / VDDS_DDR_C0		DDR	
W5	T4	DDR0_DQ3	DDR0_DQ3		IO	1.1 V					VDDS_DDR / VDDS_DDR_C0		DDR	
V4	U5	DDR0_DQ4	DDR0_DQ4		IO	1.1 V					VDDS_DDR / VDDS_DDR_C0		DDR	
V7	T3	DDR0_DQ5	DDR0_DQ5		IO	1.1 V					VDDS_DDR / VDDS_DDR_C0		DDR	
U5	T6	DDR0_DQ6	DDR0_DQ6		IO	1.1 V					VDDS_DDR / VDDS_DDR_C0		DDR	
V6	T7	DDR0_DQ7	DDR0_DQ7		IO	1.1 V					VDDS_DDR / VDDS_DDR_C0		DDR	
Y2	V4	DDR0_DQ8	DDR0_DQ8		IO	1.1 V					VDDS_DDR / VDDS_DDR_C0		DDR	
W3	V7	DDR0_DQ9	DDR0_DQ9		IO	1.1 V					VDDS_DDR / VDDS_DDR_C0		DDR	
AA3	W3	DDR0_DQ10	DDR0_DQ10		IO	1.1 V					VDDS_DDR / VDDS_DDR_C0		DDR	
W2	V5	DDR0_DQ11	DDR0_DQ11		IO	1.1 V					VDDS_DDR / VDDS_DDR_C0		DDR	
AA6	W6	DDR0_DQ12	DDR0_DQ12		IO	1.1 V					VDDS_DDR / VDDS_DDR_C0		DDR	
Y4	U2	DDR0_DQ13	DDR0_DQ13		IO	1.1 V					VDDS_DDR / VDDS_DDR_C0		DDR	
Y5	W4	DDR0_DQ14	DDR0_DQ14		IO	1.1 V					VDDS_DDR / VDDS_DDR_C0		DDR	
AA7	U3	DDR0_DQ15	DDR0_DQ15		IO	1.1 V					VDDS_DDR / VDDS_DDR_C0		DDR	
AF2	AD5	DDR0_DQ16	DDR0_DQ16		IO	1.1 V					VDDS_DDR / VDDS_DDR_C0		DDR	

Table 5-1. Pin Attributes (ALY, AND Packages) (continued)

ALY Ball Num [1]	AND Ball Num [1]	Ball Name [2] PADCFG Register [15] PADCFG Address [16]	Signal Name [3]	Mux Mode [4]	Signal Type [5]	I/O Voltage [6]	Ball State DURING Reset (RX/TX/PULL) [7]	Ball State AFTER Reset (RX/TX/PULL) [8]	Mux Mode AFTER Reset [9]	Pull Type [10]	Power [11]	Hys [12]	Voltage Buffer Type [13]	IO RET [14]
AE7	AC3	DDR0_DQ17	DDR0_DQ17		IO	1.1 V					VDDS_DDR / VDDS_DDR_C0		DDR	
AG3	AE3	DDR0_DQ18	DDR0_DQ18		IO	1.1 V					VDDS_DDR / VDDS_DDR_C0		DDR	
AF5	AB2	DDR0_DQ19	DDR0_DQ19		IO	1.1 V					VDDS_DDR / VDDS_DDR_C0		DDR	
AE6	AC4	DDR0_DQ20	DDR0_DQ20		IO	1.1 V					VDDS_DDR / VDDS_DDR_C0		DDR	
AF4	AD2	DDR0_DQ21	DDR0_DQ21		IO	1.1 V					VDDS_DDR / VDDS_DDR_C0		DDR	
AE3	AC6	DDR0_DQ22	DDR0_DQ22		IO	1.1 V					VDDS_DDR / VDDS_DDR_C0		DDR	
AE4	AD4	DDR0_DQ23	DDR0_DQ23		IO	1.1 V					VDDS_DDR / VDDS_DDR_C0		DDR	
AG5	AG4	DDR0_DQ24	DDR0_DQ24		IO	1.1 V					VDDS_DDR / VDDS_DDR_C0		DDR	
AH3	AG2	DDR0_DQ25	DDR0_DQ25		IO	1.1 V					VDDS_DDR / VDDS_DDR_C0		DDR	
AJ2	AF3	DDR0_DQ26	DDR0_DQ26		IO	1.1 V					VDDS_DDR / VDDS_DDR_C0		DDR	
AH4	AE5	DDR0_DQ27	DDR0_DQ27		IO	1.1 V					VDDS_DDR / VDDS_DDR_C0		DDR	
AJ4	AE6	DDR0_DQ28	DDR0_DQ28		IO	1.1 V					VDDS_DDR / VDDS_DDR_C0		DDR	
AH6	AG5	DDR0_DQ29	DDR0_DQ29		IO	1.1 V					VDDS_DDR / VDDS_DDR_C0		DDR	
AH7	AF4	DDR0_DQ30	DDR0_DQ30		IO	1.1 V					VDDS_DDR / VDDS_DDR_C0		DDR	
AG6	AH6	DDR0_DQ31	DDR0_DQ31		IO	1.1 V					VDDS_DDR / VDDS_DDR_C0		DDR	
V1	T1	DDR0_DQSON	DDR0_DQSON		IO	1.1 V					VDDS_DDR / VDDS_DDR_C0		DDR	

Table 5-1. Pin Attributes (ALY, AND Packages) (continued)

ALY Ball Num [1]	AND Ball Num [1]	Ball Name [2] PADCFG Register [15] PADCFG Address [16]	Signal Name [3]	Mux Mode [4]	Signal Type [5]	I/O Voltage [6]	Ball State DURING Reset (RX/TX/PULL) [7]	Ball State AFTER Reset (RX/TX/PULL) [8]	Mux Mode AFTER Reset [9]	Pull Type [10]	Power [11]	Hys [12]	Voltage Buffer Type [13]	IO RET [14]
U1	R1	DDR0_DQS0P	DDR0_DQS0P		IO	1.1 V					VDDS_DDR / VDDS_DDR_C0		DDR	
Y1	W1	DDR0_DQS1N	DDR0_DQS1N		IO	1.1 V					VDDS_DDR / VDDS_DDR_C0		DDR	
AA1	V1	DDR0_DQS1P	DDR0_DQS1P		IO	1.1 V					VDDS_DDR / VDDS_DDR_C0		DDR	
AE1	AC1	DDR0_DQS2N	DDR0_DQS2N		IO	1.1 V					VDDS_DDR / VDDS_DDR_C0		DDR	
AF1	AD1	DDR0_DQS2P	DDR0_DQS2P		IO	1.1 V					VDDS_DDR / VDDS_DDR_C0		DDR	
AH1	AF1	DDR0_DQS3N	DDR0_DQS3N		IO	1.1 V					VDDS_DDR / VDDS_DDR_C0		DDR	
AJ1	AG1	DDR0_DQS3P	DDR0_DQS3P		IO	1.1 V					VDDS_DDR / VDDS_DDR_C0		DDR	
F12	J4	DDR1_CA0	DDR1_CA0		IO	1.1 V					VDDS_DDR / VDDS_DDR_C1		DDR	
C12	H3	DDR1_CA1	DDR1_CA1		IO	1.1 V					VDDS_DDR / VDDS_DDR_C1		DDR	
B12	G2	DDR1_CA2	DDR1_CA2		IO	1.1 V					VDDS_DDR / VDDS_DDR_C1		DDR	
C11	J3	DDR1_CA3	DDR1_CA3		IO	1.1 V					VDDS_DDR / VDDS_DDR_C1		DDR	
D12	G3	DDR1_CA4	DDR1_CA4		IO	1.1 V					VDDS_DDR / VDDS_DDR_C1		DDR	
E10	H4	DDR1_CA5	DDR1_CA5		IO	1.1 V					VDDS_DDR / VDDS_DDR_C1		DDR	
G14	F8	DDR1_CAL0	DDR1_CAL0		A	1.1 V					VDDS_DDR / VDDS_DDR_C1		DDR	
D11	E7	DDR1_CKE0	DDR1_CKE0		IO	1.1 V					VDDS_DDR / VDDS_DDR_C1		DDR	
C10	H6	DDR1_CKE1	DDR1_CKE1		IO	1.1 V					VDDS_DDR / VDDS_DDR_C1		DDR	

Table 5-1. Pin Attributes (ALY, AND Packages) (continued)

ALY Ball Num [1]	AND Ball Num [1]	Ball Name [2] PADCFG Register [15] PADCFG Address [16]	Signal Name [3]	Mux Mode [4]	Signal Type [5]	I/O Voltage [6]	Ball State DURING Reset (RX/TX/PULL) [7]	Ball State AFTER Reset (RX/TX/PULL) [8]	Mux Mode AFTER Reset [9]	Pull Type [10]	Power [11]	Hys [12]	Voltage Buffer Type [13]	IO RET [14]
E11	G6	DDR1_CSn0_0	DDR1_CSn0_0		IO	1.1 V					VDDS_DDR / VDDS_DDR_C1		DDR	
G11	G7	DDR1_CSn0_1	DDR1_CSn0_1		IO	1.1 V					VDDS_DDR / VDDS_DDR_C1		DDR	
F10	H7	DDR1_CSn1_0	DDR1_CSn1_0		IO	1.1 V					VDDS_DDR / VDDS_DDR_C1		DDR	
G12	F6	DDR1_CSn1_1	DDR1_CSn1_1		IO	1.1 V					VDDS_DDR / VDDS_DDR_C1		DDR	
E17	A3	DDR1_DM0	DDR1_DM0		IO	1.1 V					VDDS_DDR / VDDS_DDR_C1		DDR	
C15	F3	DDR1_DM1	DDR1_DM1		IO	1.1 V					VDDS_DDR / VDDS_DDR_C1		DDR	
D8	L2	DDR1_DM2	DDR1_DM2		IO	1.1 V					VDDS_DDR / VDDS_DDR_C1		DDR	
C1	P2	DDR1_DM3	DDR1_DM3		IO	1.1 V					VDDS_DDR / VDDS_DDR_C1		DDR	
F16	A6	DDR1_DQ0	DDR1_DQ0		IO	1.1 V					VDDS_DDR / VDDS_DDR_C1		DDR	
G16	C6	DDR1_DQ1	DDR1_DQ1		IO	1.1 V					VDDS_DDR / VDDS_DDR_C1		DDR	
F15	A5	DDR1_DQ2	DDR1_DQ2		IO	1.1 V					VDDS_DDR / VDDS_DDR_C1		DDR	
E15	C4	DDR1_DQ3	DDR1_DQ3		IO	1.1 V					VDDS_DDR / VDDS_DDR_C1		DDR	
D16	B4	DDR1_DQ4	DDR1_DQ4		IO	1.1 V					VDDS_DDR / VDDS_DDR_C1		DDR	
C16	B2	DDR1_DQ5	DDR1_DQ5		IO	1.1 V					VDDS_DDR / VDDS_DDR_C1		DDR	
B17	C3	DDR1_DQ6	DDR1_DQ6		IO	1.1 V					VDDS_DDR / VDDS_DDR_C1		DDR	
D17	B5	DDR1_DQ7	DDR1_DQ7		IO	1.1 V					VDDS_DDR / VDDS_DDR_C1		DDR	

Table 5-1. Pin Attributes (ALY, AND Packages) (continued)

ALY Ball Num [1]	AND Ball Num [1]	Ball Name [2] PADCFG Register [15] PADCFG Address [16]	Signal Name [3]	Mux Mode [4]	Signal Type [5]	I/O Voltage [6]	Ball State DURING Reset (RX/TX/PULL) [7]	Ball State AFTER Reset (RX/TX/PULL) [8]	Mux Mode AFTER Reset [9]	Pull Type [10]	Power [11]	Hys [12]	Voltage Buffer Type [13]	IO RET [14]
B15	E5	DDR1_DQ8	DDR1_DQ8		IO	1.1 V					VDDS_DDR / VDDS_DDR_C1		DDR	
B14	D2	DDR1_DQ9	DDR1_DQ9		IO	1.1 V					VDDS_DDR / VDDS_DDR_C1		DDR	
C13	E2	DDR1_DQ10	DDR1_DQ10		IO	1.1 V					VDDS_DDR / VDDS_DDR_C1		DDR	
D13	F4	DDR1_DQ11	DDR1_DQ11		IO	1.1 V					VDDS_DDR / VDDS_DDR_C1		DDR	
F13	D6	DDR1_DQ12	DDR1_DQ12		IO	1.1 V					VDDS_DDR / VDDS_DDR_C1		DDR	
G13	E4	DDR1_DQ13	DDR1_DQ13		IO	1.1 V					VDDS_DDR / VDDS_DDR_C1		DDR	
E14	D3	DDR1_DQ14	DDR1_DQ14		IO	1.1 V					VDDS_DDR / VDDS_DDR_C1		DDR	
D14	D5	DDR1_DQ15	DDR1_DQ15		IO	1.1 V					VDDS_DDR / VDDS_DDR_C1		DDR	
E8	M3	DDR1_DQ16	DDR1_DQ16		IO	1.1 V					VDDS_DDR / VDDS_DDR_C1		DDR	
G9	K4	DDR1_DQ17	DDR1_DQ17		IO	1.1 V					VDDS_DDR / VDDS_DDR_C1		DDR	
F9	M2	DDR1_DQ18	DDR1_DQ18		IO	1.1 V					VDDS_DDR / VDDS_DDR_C1		DDR	
D9	L5	DDR1_DQ19	DDR1_DQ19		IO	1.1 V					VDDS_DDR / VDDS_DDR_C1		DDR	
C9	J5	DDR1_DQ20	DDR1_DQ20		IO	1.1 V					VDDS_DDR / VDDS_DDR_C1		DDR	
B8	K3	DDR1_DQ21	DDR1_DQ21		IO	1.1 V					VDDS_DDR / VDDS_DDR_C1		DDR	
B7	L4	DDR1_DQ22	DDR1_DQ22		IO	1.1 V					VDDS_DDR / VDDS_DDR_C1		DDR	
C7	K6	DDR1_DQ23	DDR1_DQ23		IO	1.1 V					VDDS_DDR / VDDS_DDR_C1		DDR	

Table 5-1. Pin Attributes (ALY, AND Packages) (continued)

ALY Ball Num [1]	AND Ball Num [1]	Ball Name [2] PADCFG Register [15] PADCFG Address [16]	Signal Name [3]	Mux Mode [4]	Signal Type [5]	I/O Voltage [6]	Ball State DURING Reset (RX/TX/PULL) [7]	Ball State AFTER Reset (RX/TX/PULL) [8]	Mux Mode AFTER Reset [9]	Pull Type [10]	Power [11]	Hys [12]	Voltage Buffer Type [13]	IO RET [14]
B2	N6	DDR1_DQ24	DDR1_DQ24		IO	1.1 V					VDDS_DDR / VDDS_DDR_C1		DDR	
B3	P4	DDR1_DQ25	DDR1_DQ25		IO	1.1 V					VDDS_DDR / VDDS_DDR_C1		DDR	
B4	N3	DDR1_DQ26	DDR1_DQ26		IO	1.1 V					VDDS_DDR / VDDS_DDR_C1		DDR	
B5	M5	DDR1_DQ27	DDR1_DQ27		IO	1.1 V					VDDS_DDR / VDDS_DDR_C1		DDR	
A6	M6	DDR1_DQ28	DDR1_DQ28		IO	1.1 V					VDDS_DDR / VDDS_DDR_C1		DDR	
C5	P5	DDR1_DQ29	DDR1_DQ29		IO	1.1 V					VDDS_DDR / VDDS_DDR_C1		DDR	
C6	N4	DDR1_DQ30	DDR1_DQ30		IO	1.1 V					VDDS_DDR / VDDS_DDR_C1		DDR	
C3	P6	DDR1_DQ31	DDR1_DQ31		IO	1.1 V					VDDS_DDR / VDDS_DDR_C1		DDR	
A17	C1	DDR1_DQS0N	DDR1_DQS0N		IO	1.1 V					VDDS_DDR / VDDS_DDR_C1		DDR	
A16	B1	DDR1_DQS0P	DDR1_DQS0P		IO	1.1 V					VDDS_DDR / VDDS_DDR_C1		DDR	
A14	F1	DDR1_DQS1N	DDR1_DQS1N		IO	1.1 V					VDDS_DDR / VDDS_DDR_C1		DDR	
A13	E1	DDR1_DQS1P	DDR1_DQS1P		IO	1.1 V					VDDS_DDR / VDDS_DDR_C1		DDR	
A9	K1	DDR1_DQS2N	DDR1_DQS2N		IO	1.1 V					VDDS_DDR / VDDS_DDR_C1		DDR	
A8	L1	DDR1_DQS2P	DDR1_DQS2P		IO	1.1 V					VDDS_DDR / VDDS_DDR_C1		DDR	
A4	N1	DDR1_DQS3N	DDR1_DQS3N		IO	1.1 V					VDDS_DDR / VDDS_DDR_C1		DDR	
A3	P1	DDR1_DQS3P	DDR1_DQS3P		IO	1.1 V					VDDS_DDR / VDDS_DDR_C1		DDR	

Table 5-1. Pin Attributes (ALY, AND Packages) (continued)

ALY Ball Num [1]	AND Ball Num [1]	Ball Name [2] PADCFG Register [15] PADCFG Address [16]	Signal Name [3]	Mux Mode [4]	Signal Type [5]	I/O Voltage [6]	Ball State DURING Reset (RX/TX/PULL) [7]	Ball State AFTER Reset (RX/TX/PULL) [8]	Mux Mode AFTER Reset [9]	Pull Type [10]	Power [11]	Hys [12]	Voltage Buffer Type [13]	IO RET [14]
K3		DDR2_CA0	DDR2_CA0		IO	1.1 V					VDDS_DDR / VDDS_DDR_C2		DDR	
L3		DDR2_CA1	DDR2_CA1		IO	1.1 V					VDDS_DDR / VDDS_DDR_C2		DDR	
K5		DDR2_CA2	DDR2_CA2		IO	1.1 V					VDDS_DDR / VDDS_DDR_C2		DDR	
L4		DDR2_CA3	DDR2_CA3		IO	1.1 V					VDDS_DDR / VDDS_DDR_C2		DDR	
K4		DDR2_CA4	DDR2_CA4		IO	1.1 V					VDDS_DDR / VDDS_DDR_C2		DDR	
L7		DDR2_CA5	DDR2_CA5		IO	1.1 V					VDDS_DDR / VDDS_DDR_C2		DDR	
U7		DDR2_CAL0	DDR2_CAL0		A	1.1 V					VDDS_DDR / VDDS_DDR_C2		DDR	
L6		DDR2_CKE0	DDR2_CKE0		IO	1.1 V					VDDS_DDR / VDDS_DDR_C2		DDR	
J2		DDR2_CKE1	DDR2_CKE1		IO	1.1 V					VDDS_DDR / VDDS_DDR_C2		DDR	
J3		DDR2_CSn0_0	DDR2_CSn0_0		IO	1.1 V					VDDS_DDR / VDDS_DDR_C2		DDR	
J6		DDR2_CSn0_1	DDR2_CSn0_1		IO	1.1 V					VDDS_DDR / VDDS_DDR_C2		DDR	
J7		DDR2_CSn1_0	DDR2_CSn1_0		IO	1.1 V					VDDS_DDR / VDDS_DDR_C2		DDR	
K7		DDR2_CSn1_1	DDR2_CSn1_1		IO	1.1 V					VDDS_DDR / VDDS_DDR_C2		DDR	
T2		DDR2_DM0	DDR2_DM0		IO	1.1 V					VDDS_DDR / VDDS_DDR_C2		DDR	
M6		DDR2_DM1	DDR2_DM1		IO	1.1 V					VDDS_DDR / VDDS_DDR_C2		DDR	
G4		DDR2_DM2	DDR2_DM2		IO	1.1 V					VDDS_DDR / VDDS_DDR_C2		DDR	

Table 5-1. Pin Attributes (ALY, AND Packages) (continued)

ALY Ball Num [1]	AND Ball Num [1]	Ball Name [2] PADCFG Register [15] PADCFG Address [16]	Signal Name [3]	Mux Mode [4]	Signal Type [5]	I/O Voltage [6]	Ball State DURING Reset (RX/TX/PULL) [7]	Ball State AFTER Reset (RX/TX/PULL) [8]	Mux Mode AFTER Reset [9]	Pull Type [10]	Power [11]	Hys [12]	Voltage Buffer Type [13]	IO RET [14]
D5		DDR2_DM3	DDR2_DM3		IO	1.1 V					VDDS_DDR / VDDS_DDR_C2		DDR	
T4		DDR2_DQ0	DDR2_DQ0		IO	1.1 V					VDDS_DDR / VDDS_DDR_C2		DDR	
R6		DDR2_DQ1	DDR2_DQ1		IO	1.1 V					VDDS_DDR / VDDS_DDR_C2		DDR	
R3		DDR2_DQ2	DDR2_DQ2		IO	1.1 V					VDDS_DDR / VDDS_DDR_C2		DDR	
R4		DDR2_DQ3	DDR2_DQ3		IO	1.1 V					VDDS_DDR / VDDS_DDR_C2		DDR	
P6		DDR2_DQ4	DDR2_DQ4		IO	1.1 V					VDDS_DDR / VDDS_DDR_C2		DDR	
P5		DDR2_DQ5	DDR2_DQ5		IO	1.1 V					VDDS_DDR / VDDS_DDR_C2		DDR	
T5		DDR2_DQ6	DDR2_DQ6		IO	1.1 V					VDDS_DDR / VDDS_DDR_C2		DDR	
R7		DDR2_DQ7	DDR2_DQ7		IO	1.1 V					VDDS_DDR / VDDS_DDR_C2		DDR	
N2		DDR2_DQ8	DDR2_DQ8		IO	1.1 V					VDDS_DDR / VDDS_DDR_C2		DDR	
N4		DDR2_DQ9	DDR2_DQ9		IO	1.1 V					VDDS_DDR / VDDS_DDR_C2		DDR	
P2		DDR2_DQ10	DDR2_DQ10		IO	1.1 V					VDDS_DDR / VDDS_DDR_C2		DDR	
P3		DDR2_DQ11	DDR2_DQ11		IO	1.1 V					VDDS_DDR / VDDS_DDR_C2		DDR	
M7		DDR2_DQ12	DDR2_DQ12		IO	1.1 V					VDDS_DDR / VDDS_DDR_C2		DDR	
N5		DDR2_DQ13	DDR2_DQ13		IO	1.1 V					VDDS_DDR / VDDS_DDR_C2		DDR	
M4		DDR2_DQ14	DDR2_DQ14		IO	1.1 V					VDDS_DDR / VDDS_DDR_C2		DDR	

Table 5-1. Pin Attributes (ALY, AND Packages) (continued)

ALY Ball Num [1]	AND Ball Num [1]	Ball Name [2] PADCFG Register [15] PADCFG Address [16]	Signal Name [3]	Mux Mode [4]	Signal Type [5]	I/O Voltage [6]	Ball State DURING Reset (RX/TX/PULL) [7]	Ball State AFTER Reset (RX/TX/PULL) [8]	Mux Mode AFTER Reset [9]	Pull Type [10]	Power [11]	Hys [12]	Voltage Buffer Type [13]	IO RET [14]
M3		DDR2_DQ15	DDR2_DQ15		IO	1.1 V					VDDS_DDR / VDDS_DDR_C2		DDR	
F3		DDR2_DQ16	DDR2_DQ16		IO	1.1 V					VDDS_DDR / VDDS_DDR_C2		DDR	
G7		DDR2_DQ17	DDR2_DQ17		IO	1.1 V					VDDS_DDR / VDDS_DDR_C2		DDR	
H6		DDR2_DQ18	DDR2_DQ18		IO	1.1 V					VDDS_DDR / VDDS_DDR_C2		DDR	
H4		DDR2_DQ19	DDR2_DQ19		IO	1.1 V					VDDS_DDR / VDDS_DDR_C2		DDR	
G2		DDR2_DQ20	DDR2_DQ20		IO	1.1 V					VDDS_DDR / VDDS_DDR_C2		DDR	
H3		DDR2_DQ21	DDR2_DQ21		IO	1.1 V					VDDS_DDR / VDDS_DDR_C2		DDR	
G5		DDR2_DQ22	DDR2_DQ22		IO	1.1 V					VDDS_DDR / VDDS_DDR_C2		DDR	
F2		DDR2_DQ23	DDR2_DQ23		IO	1.1 V					VDDS_DDR / VDDS_DDR_C2		DDR	
E4		DDR2_DQ24	DDR2_DQ24		IO	1.1 V					VDDS_DDR / VDDS_DDR_C2		DDR	
D2		DDR2_DQ25	DDR2_DQ25		IO	1.1 V					VDDS_DDR / VDDS_DDR_C2		DDR	
F6		DDR2_DQ26	DDR2_DQ26		IO	1.1 V					VDDS_DDR / VDDS_DDR_C2		DDR	
F5		DDR2_DQ27	DDR2_DQ27		IO	1.1 V					VDDS_DDR / VDDS_DDR_C2		DDR	
E3		DDR2_DQ28	DDR2_DQ28		IO	1.1 V					VDDS_DDR / VDDS_DDR_C2		DDR	
E7		DDR2_DQ29	DDR2_DQ29		IO	1.1 V					VDDS_DDR / VDDS_DDR_C2		DDR	
E6		DDR2_DQ30	DDR2_DQ30		IO	1.1 V					VDDS_DDR / VDDS_DDR_C2		DDR	

Table 5-1. Pin Attributes (ALY, AND Packages) (continued)

ALY Ball Num [1]	AND Ball Num [1]	Ball Name [2] PADCFG Register [15] PADCFG Address [16]	Signal Name [3]	Mux Mode [4]	Signal Type [5]	I/O Voltage [6]	Ball State DURING Reset (RX/TX/PULL) [7]	Ball State AFTER Reset (RX/TX/PULL) [8]	Mux Mode AFTER Reset [9]	Pull Type [10]	Power [11]	Hys [12]	Voltage Buffer Type [13]	IO RET [14]
D4		DDR2_DQ31	DDR2_DQ31		IO	1.1 V					VDDS_DDR / VDDS_DDR_C2		DDR	
R1		DDR2_DQS0N	DDR2_DQS0N		IO	1.1 V					VDDS_DDR / VDDS_DDR_C2		DDR	
T1		DDR2_DQS0P	DDR2_DQS0P		IO	1.1 V					VDDS_DDR / VDDS_DDR_C2		DDR	
M1		DDR2_DQS1N	DDR2_DQS1N		IO	1.1 V					VDDS_DDR / VDDS_DDR_C2		DDR	
N1		DDR2_DQS1P	DDR2_DQS1P		IO	1.1 V					VDDS_DDR / VDDS_DDR_C2		DDR	
G1		DDR2_DQS2N	DDR2_DQS2N		IO	1.1 V					VDDS_DDR / VDDS_DDR_C2		DDR	
H1		DDR2_DQS2P	DDR2_DQS2P		IO	1.1 V					VDDS_DDR / VDDS_DDR_C2		DDR	
D1		DDR2_DQS3N	DDR2_DQS3N		IO	1.1 V					VDDS_DDR / VDDS_DDR_C2		DDR	
E1		DDR2_DQS3P	DDR2_DQS3P		IO	1.1 V					VDDS_DDR / VDDS_DDR_C2		DDR	
D25		DDR3_CA0	DDR3_CA0		IO	1.1 V					VDDS_DDR / VDDS_DDR_C3		DDR	
B23		DDR3_CA1	DDR3_CA1		IO	1.1 V					VDDS_DDR / VDDS_DDR_C3		DDR	
D24		DDR3_CA2	DDR3_CA2		IO	1.1 V					VDDS_DDR / VDDS_DDR_C3		DDR	
C24		DDR3_CA3	DDR3_CA3		IO	1.1 V					VDDS_DDR / VDDS_DDR_C3		DDR	
E23		DDR3_CA4	DDR3_CA4		IO	1.1 V					VDDS_DDR / VDDS_DDR_C3		DDR	
F23		DDR3_CA5	DDR3_CA5		IO	1.1 V					VDDS_DDR / VDDS_DDR_C3		DDR	
F18		DDR3_CAL0	DDR3_CAL0		A	1.1 V					VDDS_DDR / VDDS_DDR_C3		DDR	

Table 5-1. Pin Attributes (ALY, AND Packages) (continued)

ALY Ball Num [1]	AND Ball Num [1]	Ball Name [2] PADCFG Register [15] PADCFG Address [16]	Signal Name [3]	Mux Mode [4]	Signal Type [5]	I/O Voltage [6]	Ball State DURING Reset (RX/TX/PULL) [7]	Ball State AFTER Reset (RX/TX/PULL) [8]	Mux Mode AFTER Reset [9]	Pull Type [10]	Power [11]	Hys [12]	Voltage Buffer Type [13]	IO RET [14]
C25		DDR3_CKE0	DDR3_CKE0		IO	1.1 V					VDDS_DDR / VDDS_DDR_C3		DDR	
G24		DDR3_CKE1	DDR3_CKE1		IO	1.1 V					VDDS_DDR / VDDS_DDR_C3		DDR	
G23		DDR3_CSn0_0	DDR3_CSn0_0		IO	1.1 V					VDDS_DDR / VDDS_DDR_C3		DDR	
G25		DDR3_CSn0_1	DDR3_CSn0_1		IO	1.1 V					VDDS_DDR / VDDS_DDR_C3		DDR	
F25		DDR3_CSn1_0	DDR3_CSn1_0		IO	1.1 V					VDDS_DDR / VDDS_DDR_C3		DDR	
E24		DDR3_CSn1_1	DDR3_CSn1_1		IO	1.1 V					VDDS_DDR / VDDS_DDR_C3		DDR	
E18		DDR3_DM0	DDR3_DM0		IO	1.1 V					VDDS_DDR / VDDS_DDR_C3		DDR	
D21		DDR3_DM1	DDR3_DM1		IO	1.1 V					VDDS_DDR / VDDS_DDR_C3		DDR	
C28		DDR3_DM2	DDR3_DM2		IO	1.1 V					VDDS_DDR / VDDS_DDR_C3		DDR	
E30		DDR3_DM3	DDR3_DM3		IO	1.1 V					VDDS_DDR / VDDS_DDR_C3		DDR	
D18		DDR3_DQ0	DDR3_DQ0		IO	1.1 V					VDDS_DDR / VDDS_DDR_C3		DDR	
B18		DDR3_DQ1	DDR3_DQ1		IO	1.1 V					VDDS_DDR / VDDS_DDR_C3		DDR	
C19		DDR3_DQ2	DDR3_DQ2		IO	1.1 V					VDDS_DDR / VDDS_DDR_C3		DDR	
D19		DDR3_DQ3	DDR3_DQ3		IO	1.1 V					VDDS_DDR / VDDS_DDR_C3		DDR	
F20		DDR3_DQ4	DDR3_DQ4		IO	1.1 V					VDDS_DDR / VDDS_DDR_C3		DDR	
E20		DDR3_DQ5	DDR3_DQ5		IO	1.1 V					VDDS_DDR / VDDS_DDR_C3		DDR	

Table 5-1. Pin Attributes (ALY, AND Packages) (continued)

ALY Ball Num [1]	AND Ball Num [1]	Ball Name [2] PADCFG Register [15] PADCFG Address [16]	Signal Name [3]	Mux Mode [4]	Signal Type [5]	I/O Voltage [6]	Ball State DURING Reset (RX/TX/PULL) [7]	Ball State AFTER Reset (RX/TX/PULL) [8]	Mux Mode AFTER Reset [9]	Pull Type [10]	Power [11]	Hys [12]	Voltage Buffer Type [13]	IO RET [14]
G19		DDR3_DQ6	DDR3_DQ6		IO	1.1 V					VDDS_DDR / VDDS_DDR_C3		DDR	
F19		DDR3_DQ7	DDR3_DQ7		IO	1.1 V					VDDS_DDR / VDDS_DDR_C3		DDR	
E21		DDR3_DQ8	DDR3_DQ8		IO	1.1 V					VDDS_DDR / VDDS_DDR_C3		DDR	
G21		DDR3_DQ9	DDR3_DQ9		IO	1.1 V					VDDS_DDR / VDDS_DDR_C3		DDR	
F22		DDR3_DQ10	DDR3_DQ10		IO	1.1 V					VDDS_DDR / VDDS_DDR_C3		DDR	
D22		DDR3_DQ11	DDR3_DQ11		IO	1.1 V					VDDS_DDR / VDDS_DDR_C3		DDR	
C22		DDR3_DQ12	DDR3_DQ12		IO	1.1 V					VDDS_DDR / VDDS_DDR_C3		DDR	
B21		DDR3_DQ13	DDR3_DQ13		IO	1.1 V					VDDS_DDR / VDDS_DDR_C3		DDR	
B20		DDR3_DQ14	DDR3_DQ14		IO	1.1 V					VDDS_DDR / VDDS_DDR_C3		DDR	
C20		DDR3_DQ15	DDR3_DQ15		IO	1.1 V					VDDS_DDR / VDDS_DDR_C3		DDR	
B28		DDR3_DQ16	DDR3_DQ16		IO	1.1 V					VDDS_DDR / VDDS_DDR_C3		DDR	
B27		DDR3_DQ17	DDR3_DQ17		IO	1.1 V					VDDS_DDR / VDDS_DDR_C3		DDR	
C26		DDR3_DQ18	DDR3_DQ18		IO	1.1 V					VDDS_DDR / VDDS_DDR_C3		DDR	
D26		DDR3_DQ19	DDR3_DQ19		IO	1.1 V					VDDS_DDR / VDDS_DDR_C3		DDR	
F26		DDR3_DQ20	DDR3_DQ20		IO	1.1 V					VDDS_DDR / VDDS_DDR_C3		DDR	
G26		DDR3_DQ21	DDR3_DQ21		IO	1.1 V					VDDS_DDR / VDDS_DDR_C3		DDR	

Table 5-1. Pin Attributes (ALY, AND Packages) (continued)

ALY Ball Num [1]	AND Ball Num [1]	Ball Name [2] PADCFG Register [15] PADCFG Address [16]	Signal Name [3]	Mux Mode [4]	Signal Type [5]	I/O Voltage [6]	Ball State DURING Reset (RX/TX/PULL) [7]	Ball State AFTER Reset (RX/TX/PULL) [8]	Mux Mode AFTER Reset [9]	Pull Type [10]	Power [11]	Hys [12]	Voltage Buffer Type [13]	IO RET [14]
E27		DDR3_DQ22	DDR3_DQ22		IO	1.1 V					VDDS_DDR / VDDS_DDR_C3		DDR	
D27		DDR3_DQ23	DDR3_DQ23		IO	1.1 V					VDDS_DDR / VDDS_DDR_C3		DDR	
F29		DDR3_DQ24	DDR3_DQ24		IO	1.1 V					VDDS_DDR / VDDS_DDR_C3		DDR	
G29		DDR3_DQ25	DDR3_DQ25		IO	1.1 V					VDDS_DDR / VDDS_DDR_C3		DDR	
F28		DDR3_DQ26	DDR3_DQ26		IO	1.1 V					VDDS_DDR / VDDS_DDR_C3		DDR	
E28		DDR3_DQ27	DDR3_DQ27		IO	1.1 V					VDDS_DDR / VDDS_DDR_C3		DDR	
D29		DDR3_DQ28	DDR3_DQ28		IO	1.1 V					VDDS_DDR / VDDS_DDR_C3		DDR	
C29		DDR3_DQ29	DDR3_DQ29		IO	1.1 V					VDDS_DDR / VDDS_DDR_C3		DDR	
B30		DDR3_DQ30	DDR3_DQ30		IO	1.1 V					VDDS_DDR / VDDS_DDR_C3		DDR	
D30		DDR3_DQ31	DDR3_DQ31		IO	1.1 V					VDDS_DDR / VDDS_DDR_C3		DDR	
A19		DDR3_DQS0N	DDR3_DQS0N		IO	1.1 V					VDDS_DDR / VDDS_DDR_C3		DDR	
A18		DDR3_DQS0P	DDR3_DQS0P		IO	1.1 V					VDDS_DDR / VDDS_DDR_C3		DDR	
A22		DDR3_DQS1N	DDR3_DQS1N		IO	1.1 V					VDDS_DDR / VDDS_DDR_C3		DDR	
A21		DDR3_DQS1P	DDR3_DQS1P		IO	1.1 V					VDDS_DDR / VDDS_DDR_C3		DDR	
A27		DDR3_DQS2N	DDR3_DQS2N		IO	1.1 V					VDDS_DDR / VDDS_DDR_C3		DDR	
A26		DDR3_DQS2P	DDR3_DQS2P		IO	1.1 V					VDDS_DDR / VDDS_DDR_C3		DDR	

Table 5-1. Pin Attributes (ALY, AND Packages) (continued)

ALY Ball Num [1]	AND Ball Num [1]	Ball Name [2] PADCFG Register [15] PADCFG Address [16]	Signal Name [3]	Mux Mode [4]	Signal Type [5]	I/O Voltage [6]	Ball State DURING Reset (RX/TX/PULL) [7]	Ball State AFTER Reset (RX/TX/PULL) [8]	Mux Mode AFTER Reset [9]	Pull Type [10]	Power [11]	Hys [12]	Voltage Buffer Type [13]	IO RET [14]
A30		DDR3_DQS3N	DDR3_DQS3N		IO	1.1 V					VDD5_DDR / VDD5_DDR_C3		DDR	
A29		DDR3_DQS3P	DDR3_DQS3P		IO	1.1 V					VDD5_DDR / VDD5_DDR_C3		DDR	
AP22	AJ25	DP0_AUXN	DP0_AUXN		IO	1.8 V					VDDA_1P8_SERDES2_4		AUX-PHY	
AP23	AJ24	DP0_AUXP	DP0_AUXP		IO	1.8 V					VDDA_1P8_SERDES2_4		AUX-PHY	
AP26	AJ28	DSI0_TXCLKN	CSI0_TXCLKN		O	1.8 V					VDDA_0P8_DSITX / VDDA_0P8_DSITX_C / VDDA_1P8_DSITX		D-PHY	
			DSI0_TXCLKN		O									
AP25	AJ27	DSI0_TXCLKP	DSI0_TXCLKP		O	1.8 V					VDDA_0P8_DSITX / VDDA_0P8_DSITX_C / VDDA_1P8_DSITX		D-PHY	
			CSI0_TXCLKP		O									
AM24	AH25	DSI0_TXRCALIB	DSI0_TXRCALIB		A	1.8 V					VDDA_0P8_DSITX / VDDA_0P8_DSITX_C / VDDA_1P8_DSITX		D-PHY	
AP29	AJ31	DSI1_TXCLKN	CSI1_TXCLKN		O	1.8 V					VDDA_0P8_DSITX / VDDA_0P8_DSITX_C / VDDA_1P8_DSITX		D-PHY	
			DSI1_TXCLKN		O									
AP28	AJ30	DSI1_TXCLKP	DSI1_TXCLKP		O	1.8 V					VDDA_0P8_DSITX / VDDA_0P8_DSITX_C / VDDA_1P8_DSITX		D-PHY	
			CSI1_TXCLKP		O									
AL22	AH27	DSI1_TXRCALIB	DSI1_TXRCALIB		A	1.8 V					VDDA_0P8_DSITX / VDDA_0P8_DSITX_C / VDDA_1P8_DSITX		D-PHY	
AU27	AL26	DSI0_TXN0	CSI0_TXN0		O	1.8 V					VDDA_0P8_DSITX / VDDA_0P8_DSITX_C / VDDA_1P8_DSITX		D-PHY	
			DSI0_TXN0		IO									

Table 5-1. Pin Attributes (ALY, AND Packages) (continued)

ALY Ball Num [1]	AND Ball Num [1]	Ball Name [2] PADCFG Register [15] PADCFG Address [16]	Signal Name [3]	Mux Mode [4]	Signal Type [5]	I/O Voltage [6]	Ball State DURING Reset (RX/TX/PULL) [7]	Ball State AFTER Reset (RX/TX/PULL) [8]	Mux Mode AFTER Reset [9]	Pull Type [10]	Power [11]	Hys [12]	Voltage Buffer Type [13]	IO RET [14]
AT26	AK27	DSIO_TXN1	CSIO_TXN1		O	1.8 V					VDDA_0P8_DSITX / VDDA_0P8_DSITX_C / VDDA_1P8_DSITX		D-PHY	
			DSIO_TXN1		O									
AR27	AM25	DSIO_TXN2	CSIO_TXN2		O	1.8 V					VDDA_0P8_DSITX / VDDA_0P8_DSITX_C / VDDA_1P8_DSITX		D-PHY	
			DSIO_TXN2		O									
AN24	AN24	DSIO_TXN3	DSIO_TXN3		O	1.8 V					VDDA_0P8_DSITX / VDDA_0P8_DSITX_C / VDDA_1P8_DSITX		D-PHY	
			CSIO_TXN3		O									
AU26	AL25	DSIO_TXP0	DSIO_TXP0		IO	1.8 V					VDDA_0P8_DSITX / VDDA_0P8_DSITX_C / VDDA_1P8_DSITX		D-PHY	
			CSIO_TXP0		O									
AT25	AK26	DSIO_TXP1	DSIO_TXP1		O	1.8 V					VDDA_0P8_DSITX / VDDA_0P8_DSITX_C / VDDA_1P8_DSITX		D-PHY	
			CSIO_TXP1		O									
AR26	AM24	DSIO_TXP2	CSIO_TXP2		O	1.8 V					VDDA_0P8_DSITX / VDDA_0P8_DSITX_C / VDDA_1P8_DSITX		D-PHY	
			DSIO_TXP2		O									
AN23	AN23	DSIO_TXP3	CSIO_TXP3		O	1.8 V					VDDA_0P8_DSITX / VDDA_0P8_DSITX_C / VDDA_1P8_DSITX		D-PHY	
			DSIO_TXP3		O									
AT29	AK30	DSI1_TXN0	DSI1_TXN0		IO	1.8 V					VDDA_0P8_DSITX / VDDA_0P8_DSITX_C / VDDA_1P8_DSITX		D-PHY	
			CSIO_TXN0		O									
AN27	AL29	DSI1_TXN1	DSI1_TXN1		O	1.8 V					VDDA_0P8_DSITX / VDDA_0P8_DSITX_C / VDDA_1P8_DSITX		D-PHY	
			CSIO_TXN1		O									

Table 5-1. Pin Attributes (ALY, AND Packages) (continued)

ALY Ball Num [1]	AND Ball Num [1]	Ball Name [2] PADCFG Register [15] PADCFG Address [16]	Signal Name [3]	Mux Mode [4]	Signal Type [5]	I/O Voltage [6]	Ball State DURING Reset (RX/TX/PULL) [7]	Ball State AFTER Reset (RX/TX/PULL) [8]	Mux Mode AFTER Reset [9]	Pull Type [10]	Power [11]	Hys [12]	Voltage Buffer Type [13]	IO RET [14]
AV28	AM28	DSI1_TXN2	CSI1_TXN2		O	1.8 V					VDDA_0P8_DSITX / VDDA_0P8_DSITX_C / VDDA_1P8_DSITX		D-PHY	
			DSI1_TXN2		O									
AU30	AN27	DSI1_TXN3	DSI1_TXN3		O	1.8 V					VDDA_0P8_DSITX / VDDA_0P8_DSITX_C / VDDA_1P8_DSITX		D-PHY	
			CSI1_TXN3		O									
AT28	AK29	DSI1_TXP0	DSI1_TXP0		IO	1.8 V					VDDA_0P8_DSITX / VDDA_0P8_DSITX_C / VDDA_1P8_DSITX		D-PHY	
			CSI1_TXP0		O									
AN26	AL28	DSI1_TXP1	DSI1_TXP1		O	1.8 V					VDDA_0P8_DSITX / VDDA_0P8_DSITX_C / VDDA_1P8_DSITX		D-PHY	
			CSI1_TXP1		O									
AV27	AM27	DSI1_TXP2	DSI1_TXP2		O	1.8 V					VDDA_0P8_DSITX / VDDA_0P8_DSITX_C / VDDA_1P8_DSITX		D-PHY	
			CSI1_TXP2		O									
AU29	AN26	DSI1_TXP3	DSI1_TXP3		O	1.8 V					VDDA_0P8_DSITX / VDDA_0P8_DSITX_C / VDDA_1P8_DSITX		D-PHY	
			CSI1_TXP3		O									

Table 5-1. Pin Attributes (ALY, AND Packages) (continued)

ALY Ball Num [1]	AND Ball Num [1]	Ball Name [2] PADCFG Register [15] PADCFG Address [16]	Signal Name [3]	Mux Mode [4]	Signal Type [5]	I/O Voltage [6]	Ball State DURING Reset (RX/TX/PULL) [7]	Ball State AFTER Reset (RX/TX/PULL) [8]	Mux Mode AFTER Reset [9]	Pull Type [10]	Power [11]	Hys [12]	Voltage Buffer Type [13]	IO RET [14]																																																												
AD36	L31	ECAP0_IN_APWM_OUT PADCFG: PADCONFIG_49 0x0011C0C4	ECAP0_IN_APWM_OUT	0	IO	1.8 V/3.3 V	Off / Off / Off	Off / Off / Off	7	PU/PD	VDDSHV2	Yes	LVCMOS	Yes																																																												
			MCASP4_AXR2	1	IO																																																																					
			CPTS0_RFT_CLK	2	I																																																																					
			MCAN12_TX	4	O																																																																					
			VOUT0_DATA23	5	O																																																																					
			GPMC0_AD5	6	IO																																																																					
			GPIO0_49	7	IO																																																																					
			SPI6_D0	8	IO																																																																					
			SYNC0_OUT	9	O																																																																					
			TRC_DATA1	10	O																																																																					
			UART2_CTSn	11	I																																																																					
			CPTS0_HW1TSPUSH	12	I																																																																					
			I2C1_SCL	13	IOD																																																																					
			UART3_RXD	14	I																																																																					
F35	F19	EMU0 PADCFG: WKUP_PADCONFIG_75 0x4301C12C	EMU0	0	IO	1.8 V/3.3 V	On / Off / Up	On / Off / Up	0	PU/PD	VDDSHV0_MCU	Yes	LVCMOS	No																																																												
H34	E17	EMU1 PADCFG: WKUP_PADCONFIG_76 0x4301C130	EMU1	0	IO	1.8 V/3.3 V	On / Off / Up	On / Off / Up	0	PU/PD	VDDSHV0_MCU	Yes	LVCMOS	No																																																												
			MCU_OBSCLK0	15	O										AN35	Y29	EXTINTn PADCFG: PADCONFIG_0 0x0011C000	EXTINTn	0	I	1.8 V/3.3 V	Off / Off / Off	Off / SS / Off	7		VDDSHV0	Yes	I2C OPEN DRAIN	No				GPIO0_0	7	IO	AJ32	J33	EXT_REFCLK1 PADCFG: PADCONFIG_50 0x0011C0C8	EXT_REFCLK1	0	I	1.8 V/3.3 V	Off / Off / Off	Off / Off / Off	7	PU/PD	VDDSHV2	Yes	LVCMOS	Yes	MCASP4_ACLKX	1	IO	VOUT0_DATA16	2	O	MCAN1_RX	4	I	GPMC0_AD6	6	IO	GPIO0_50	7	IO	SYNC1_OUT	9	O	TRC_CLK	10	O	UART2_RTSn	11	O
AN35	Y29	EXTINTn PADCFG: PADCONFIG_0 0x0011C000	EXTINTn	0	I	1.8 V/3.3 V	Off / Off / Off	Off / SS / Off	7		VDDSHV0	Yes	I2C OPEN DRAIN	No																																																												
															GPIO0_0	7	IO	AJ32	J33	EXT_REFCLK1 PADCFG: PADCONFIG_50 0x0011C0C8	EXT_REFCLK1	0	I	1.8 V/3.3 V	Off / Off / Off	Off / Off / Off	7	PU/PD	VDDSHV2	Yes	LVCMOS	Yes	MCASP4_ACLKX	1	IO				VOUT0_DATA16	2	O										MCAN1_RX	4	I	GPMC0_AD6	6	IO	GPIO0_50	7	IO	SYNC1_OUT	9	O	TRC_CLK	10	O	UART2_RTSn	11	O	CPTS0_HW2TSPUSH	12	I	I2C1_SDA	13	IOD
AJ32	J33	EXT_REFCLK1 PADCFG: PADCONFIG_50 0x0011C0C8	EXT_REFCLK1	0	I	1.8 V/3.3 V	Off / Off / Off	Off / Off / Off	7	PU/PD	VDDSHV2	Yes	LVCMOS	Yes																																																												
			MCASP4_ACLKX	1	IO																																																																					
			VOUT0_DATA16	2	O																																																																					
			MCAN1_RX	4	I																																																																					
			GPMC0_AD6	6	IO																																																																					
			GPIO0_50	7	IO																																																																					
			SYNC1_OUT	9	O																																																																					
			TRC_CLK	10	O																																																																					
			UART2_RTSn	11	O																																																																					
			CPTS0_HW2TSPUSH	12	I																																																																					
			I2C1_SDA	13	IOD																																																																					
			UART3_TXD	14	O																																																																					

Table 5-1. Pin Attributes (ALY, AND Packages) (continued)

ALY Ball Num [1]	AND Ball Num [1]	Ball Name [2] PADCFG Register [15] PADCFG Address [16]	Signal Name [3]	Mux Mode [4]	Signal Type [5]	I/O Voltage [6]	Ball State DURING Reset (RX/TX/PULL) [7]	Ball State AFTER Reset (RX/TX/PULL) [8]	Mux Mode AFTER Reset [9]	Pull Type [10]	Power [11]	Hys [12]	Voltage Buffer Type [13]	IO RET [14]
AL32	P32	GPIO0_11 PADCFG: PADCONFIG_11 0x0011C02C	MCAN17_TX	0	O	1.8 V/3.3 V	Off / Off / Off	Off / Off / Off	7	PU/PD	VDDSHV2	Yes	LVCMOS	Yes
			VOUT0_DATA18	2	O									
			GPMC0_A14	6	OZ									
			GPIO0_11	7	IO									
			SPI7_CS3	8	IO									
			TRC_DATA25	10	O									
			GPMC0_CSn2	12	O									
			UART7_RXD	13	I									
USB0_DRVVBUS	14	O												
AK37	E33	GPIO0_12 PADCFG: PADCONFIG_12 0x0011C030	MCAN12_RX	0	I	1.8 V/3.3 V	Off / Off / Off	Off / Off / Off	7	PU/PD	VDDSHV2	Yes	LVCMOS	Yes
			VOUT0_DATA17	2	O									
			VOUT0_DATA22	5	O									
			GPMC0_AD4	6	IO									
			GPIO0_12	7	IO									
			SPI6_CLK	8	IO									
			EQEP1_I	9	IO									
			TRC_DATA2	10	O									
			UART9_CTSn	11	I									
UART6_RXD	12	I												
AN36	AA30	I2C0_SCL PADCFG: PADCONFIG_56 0x0011C0E0	I2C0_SCL	0	IOD	1.8 V/3.3 V	Off / Off / Off	On / SS / Off	7		VDDSHV0	Yes	I2C OPEN DRAIN	No
			GPIO0_56	7	IO									
AP37	Y30	I2C0_SDA PADCFG: PADCONFIG_57 0x0011C0E4	I2C0_SDA	0	IOD	1.8 V/3.3 V	Off / Off / Off	On / SS / Off	7		VDDSHV0	Yes	I2C OPEN DRAIN	No
			GPIO0_57	7	IO									
AE38	G29	MCAN0_RX PADCFG: PADCONFIG_26 0x0011C068	MCAN0_RX	0	I	1.8 V/3.3 V	Off / Off / Off	Off / Off / Off	7	PU/PD	VDDSHV2	Yes	LVCMOS	Yes
			MCASP4_AXR1	1	IO									
			VOUT0_DATA3	2	O									
			GPMC0_AD15	6	IO									
			GPIO0_26	7	IO									
			SPI5_CS0	8	IO									
			EHRPWM0_A	9	IO									
			TRC_DATA16	10	O									
			UART2_TXD	11	O									
			UART6_RTSn	12	O									
SPI7_D0	13	IO												

Table 5-1. Pin Attributes (ALY, AND Packages) (continued)

ALY Ball Num [1]	AND Ball Num [1]	Ball Name [2] PADCFG Register [15] PADCFG Address [16]	Signal Name [3]	Mux Mode [4]	Signal Type [5]	I/O Voltage [6]	Ball State DURING Reset (RX/TX/PULL) [7]	Ball State AFTER Reset (RX/TX/PULL) [8]	Mux Mode AFTER Reset [9]	Pull Type [10]	Power [11]	Hys [12]	Voltage Buffer Type [13]	IO RET [14]
AF38	N33	MCAN0_TX PADCFG: PADCONFIG_25 0x0011C064	MCAN0_TX	0	O	1.8 V/3.3 V	Off / Off / Off	Off / Off / Off	7	PU/PD	VDDSHV2	Yes	LVCMOS	Yes
			MCASP2_AXR2	1	IO									
			VOUT0_DATA4	2	O									
			GPMC0_AD14	6	IO									
			GPIO0_25	7	IO									
			SPI5_CS1	8	IO									
			EHRPWM0_B	9	IO									
			TRC_DATA11	10	O									
			UART2_RXD	11	I									
			UART6_CTSn	12	I									
			I2C3_SCL	13	IOD									
AH38	H31	MCAN1_RX PADCFG: PADCONFIG_28 0x0011C070	MCAN1_RX	0	I	1.8 V/3.3 V	Off / Off / Off	Off / Off / Off	7	PU/PD	VDDSHV2	Yes	LVCMOS	Yes
			MCASP4_AXR3	1	IO									
			VOUT0_DATA1	2	O									
			VOUT0_DATA19	5	O									
			GPMC0_BE0n_CLE	6	O									
			GPIO0_28	7	IO									
			SPI5_D0	8	IO									
			EHRPWM0_SYNCI	9	I									
			TRC_DATA5	10	O									
			UART3_RTSn	11	O									
			AJ37	G33	MCAN1_TX PADCFG: PADCONFIG_27 0x0011C06C									
MCASP4_AFSX	1	IO												
VOUT0_EXTPCLKIN	2	I												
DSS_FSYNC0	4	O												
GPMC0_AD7	6	IO												
GPIO0_27	7	IO												
EHRPWM_TZn_IN5	9	I												
TRC_CTL	10	O												
UART6_TXD	11	O												

Table 5-1. Pin Attributes (ALY, AND Packages) (continued)

ALY Ball Num [1]	AND Ball Num [1]	Ball Name [2] PADCFG Register [15] PADCFG Address [16]	Signal Name [3]	Mux Mode [4]	Signal Type [5]	I/O Voltage [6]	Ball State DURING Reset (RX/TX/PULL) [7]	Ball State AFTER Reset (RX/TX/PULL) [8]	Mux Mode AFTER Reset [9]	Pull Type [10]	Power [11]	Hys [12]	Voltage Buffer Type [13]	IO RET [14]
AH37	F33	MCAN2_RX PADCFG: PADCONFIG_30 0x0011C078	MCAN2_RX	0	I	1.8 V/3.3 V	Off / Off / Off	Off / Off / Off	7	PU/PD	VDDSHV2	Yes	LVCMOS	Yes
			AUDIO_EXT_REFCLK1	1	IO									
			VOUT0_PCLK	2	O									
			GPMC0_CSn1	6	O									
			GPIO0_30	7	IO									
			SPI6_CS1	8	IO									
			EHRPWM4_B	9	IO									
			TRC_DATA17	10	O									
			UART3_TXD	11	O									
			GPMC0_DIR	12	O									
I2C5_SDA	13	IOD												
AC33	G28	MCAN2_TX PADCFG: PADCONFIG_29 0x0011C074	MCAN2_TX	0	O	1.8 V/3.3 V	Off / Off / Off	Off / Off / Off	7	PU/PD	VDDSHV2	Yes	LVCMOS	Yes
			MCASP2_AXR3	1	IO									
			VOUT0_DATA0	2	O									
			VOUT0_DATA18	5	O									
			GPMC0_WAIT0	6	I									
			GPIO0_29	7	IO									
			SPI6_D1	8	IO									
			EHRPWM1_B	9	IO									
			TRC_DATA3	10	O									
			UART3_RXD	11	I									
GPMC0_DIR	12	O												
I2C5_SCL	13	IOD												
AJ33	T29	MCAN12_RX PADCFG: PADCONFIG_2 0x0011C008	MCAN12_RX	0	I	1.8 V/3.3 V	Off / Off / Off	Off / Off / Off	7	PU/PD	VDDSHV2	Yes	LVCMOS	Yes
			UART0_DCDn	1	I									
			DSS_FSYNC1	3	O									
			GPMC0_A23	6	OZ									
			GPIO0_2	7	IO									
			TRC_CTL	10	O									
			UART5_RXD	11	I									
GPMC0_CSn3	12	O												

Table 5-1. Pin Attributes (ALY, AND Packages) (continued)

ALY Ball Num [1]	AND Ball Num [1]	Ball Name [2] PADCFG Register [15] PADCFG Address [16]	Signal Name [3]	Mux Mode [4]	Signal Type [5]	I/O Voltage [6]	Ball State DURING Reset (RX/TX/PULL) [7]	Ball State AFTER Reset (RX/TX/PULL) [8]	Mux Mode AFTER Reset [9]	Pull Type [10]	Power [11]	Hys [12]	Voltage Buffer Type [13]	IO RET [14]
AG36	P29	MCAN12_TX PADCFG: PADCONFIG_1 0x0011C004	MCAN12_TX	0	O	1.8 V/3.3 V	Off / Off / Off	Off / Off / Off	7	PU/PD	VDDSHV2	Yes	LVCMOS	Yes
			DSS_FSYNC0	3	O									
			GPMC0_A24	6	OZ									
			GPIO0_1	7	IO									
			TRC_CLK	10	O									
			UART5_TXD	11	O									
			GPMC0_CLK	12	IO									
AH33	T32	MCAN13_RX PADCFG: PADCONFIG_4 0x0011C010	MCAN13_RX	0	I	1.8 V/3.3 V	Off / Off / Off	Off / Off / Off	7	PU/PD	VDDSHV2	Yes	LVCMOS	Yes
			UART0_DTRn	1	O									
			DSS_FSYNC3	3	O									
			GPMC0_A21	6	OZ									
			GPIO0_4	7	IO									
			I2C4_SDA	8	IOD									
			TRC_DATA1	10	O									
UART6_TXD	11	O												
AF33	T31	MCAN13_TX PADCFG: PADCONFIG_3 0x0011C00C	MCAN13_TX	0	O	1.8 V/3.3 V	Off / Off / Off	Off / Off / Off	7	PU/PD	VDDSHV2	Yes	LVCMOS	Yes
			UART0_DSRn	1	I									
			DSS_FSYNC2	3	O									
			GPMC0_A22	6	OZ									
			GPIO0_3	7	IO									
			TRC_DATA0	10	O									
			UART4_TXD	11	O									
GPMC0_WAIT2	12	I												
AK36	R30	MCAN14_RX PADCFG: PADCONFIG_6 0x0011C018	MCAN14_RX	0	I	1.8 V/3.3 V	Off / Off / Off	Off / Off / Off	7	PU/PD	VDDSHV2	Yes	LVCMOS	Yes
			VOU0_DATA23	2	O									
			GPMC0_A19	6	OZ									
			GPIO0_6	7	IO									
			I2C5_SDA	8	IOD									
			TRC_DATA3	10	O									
UART9_TXD	11	O												

Table 5-1. Pin Attributes (ALY, AND Packages) (continued)

ALY Ball Num [1]	AND Ball Num [1]	Ball Name [2] PADCFG Register [15] PADCFG Address [16]	Signal Name [3]	Mux Mode [4]	Signal Type [5]	I/O Voltage [6]	Ball State DURING Reset (RX/TX/PULL) [7]	Ball State AFTER Reset (RX/TX/PULL) [8]	Mux Mode AFTER Reset [9]	Pull Type [10]	Power [11]	Hys [12]	Voltage Buffer Type [13]	IO RET [14]
AG33	R33	MCAN14_TX PADCFG: PADCONFIG_5 0x0011C014	MCAN14_TX	0	O	1.8 V/3.3 V	Off / Off / Off	Off / Off / Off	7	PU/PD	VDDSHV2	Yes	LVCMOS	Yes
			UART0_RIn	1	I									
			GPMC0_A20	6	OZ									
			GPIO0_5	7	IO									
			I2C4_SCL	8	IOD									
			TRC_DATA2	10	O									
			UART6_RXD	11	I									
DP0_HPDP	13	I												
AJ35	R31	MCAN15_RX PADCFG: PADCONFIG_8 0x0011C020	MCAN15_RX	0	I	1.8 V/3.3 V	Off / Off / Off	Off / Off / Off	7	PU/PD	VDDSHV2	Yes	LVCMOS	Yes
			VOUT0_DATA21	2	O									
			GPMC0_A17	6	OZ									
			GPIO0_8	7	IO									
			SPI0_CS2	8	IO									
			TRC_DATA22	10	O									
I2C1_SCL	12	IOD												
AG34	R29	MCAN15_TX PADCFG: PADCONFIG_7 0x0011C01C	MCAN15_TX	0	O	1.8 V/3.3 V	Off / Off / Off	Off / Off / Off	7	PU/PD	VDDSHV2	Yes	LVCMOS	Yes
			VOUT0_DATA22	2	O									
			GPMC0_A18	6	OZ									
			GPIO0_7	7	IO									
			I2C5_SCL	8	IOD									
			TRC_DATA21	10	O									
UART9_RXD	11	I												
AE33	U30	MCAN16_RX PADCFG: PADCONFIG_10 0x0011C028	MCAN16_RX	0	I	1.8 V/3.3 V	Off / Off / Off	Off / Off / Off	7	PU/PD	VDDSHV2	Yes	LVCMOS	Yes
			VOUT0_DATA19	2	O									
			GPMC0_A15	6	OZ									
			GPIO0_10	7	IO									
			SPI0_CS3	8	IO									
			TRC_DATA24	10	O									
GPMC0_WAIT1	12	I												
AH34	G30	MCAN16_TX PADCFG: PADCONFIG_9 0x0011C024	MCAN16_TX	0	O	1.8 V/3.3 V	Off / Off / Off	Off / Off / Off	7	PU/PD	VDDSHV2	Yes	LVCMOS	Yes
			VOUT0_DATA20	2	O									
			GPMC0_A16	6	OZ									
			GPIO0_9	7	IO									
			SPI1_CS3	8	IO									
			TRC_DATA23	10	O									
I2C1_SDA	12	IOD												

Table 5-1. Pin Attributes (ALY, AND Packages) (continued)

ALY Ball Num [1]	AND Ball Num [1]	Ball Name [2] PADCFG Register [15] PADCFG Address [16]	Signal Name [3]	Mux Mode [4]	Signal Type [5]	I/O Voltage [6]	Ball State DURING Reset (RX/TX/PULL) [7]	Ball State AFTER Reset (RX/TX/PULL) [8]	Mux Mode AFTER Reset [9]	Pull Type [10]	Power [11]	Hys [12]	Voltage Buffer Type [13]	IO RET [14]
AK35	J30	MCASP0_ACLKX PADCFG: PADCONFIG_14 0x0011C038	MCAN5_TX	0	O	1.8 V/3.3 V	Off / Off / Off	Off / Off / Off	7	PU/PD	VDDSHV2	Yes	LVCMOS	Yes
			MCASP0_ACLKX	1	IO									
			VOUT0_DATA15	2	O									
			GPMC0_AD0	6	IO									
			GPIO0_14	7	IO									
			EHRPWM_TZn_IN2	9	I									
			UART8_RXD	11	I									
AK38	K31	MCASP0_AFSX PADCFG: PADCONFIG_15 0x0011C03C	MCAN5_RX	0	I	1.8 V/3.3 V	Off / Off / Off	Off / Off / Off	7	PU/PD	VDDSHV2	Yes	LVCMOS	Yes
			MCASP0_AFSX	1	IO									
			VOUT0_DATA14	2	O									
			GPMC0_AD1	6	IO									
			GPIO0_15	7	IO									
			EHRPWM2_B	9	IO									
			UART8_TXD	11	O									
AC34	U32	MCASP1_ACLKX PADCFG: PADCONFIG_46 0x0011C0B8	MCAN10_RX	0	I	1.8 V/3.3 V	Off / Off / Off	Off / Off / Off	7	PU/PD	VDDSHV2	Yes	LVCMOS	Yes
			MCASP1_ACLKX	1	IO									
			DP0_HPD	3	I									
			PCIE0_CLKREQn	4	IO									
			GPMC0_A11	5	OZ									
			RGMI1_RD0	6	I									
			GPIO0_46	7	IO									
			EQEP0_S	9	IO									
			UART4_RTSn	11	O									
			SPI3_CS3	12	IO									
			UART9_RTSn	13	O									
AD33	N32	MCASP1_AFSX PADCFG: PADCONFIG_47 0x0011C0BC	MCAN11_TX	0	O	1.8 V/3.3 V	Off / Off / Off	Off / Off / Off	7	PU/PD	VDDSHV2	Yes	LVCMOS	Yes
			MCASP1_AFSX	1	IO									
			GPMC0_A12	5	OZ									
			MDIO0_MDIO	6	IO									
			GPIO0_47	7	IO									
			SPI3_CS0	8	IO									
			EQEP0_I	9	IO									
			UART0_RXD	11	I									

Table 5-1. Pin Attributes (ALY, AND Packages) (continued)

ALY Ball Num [1]	AND Ball Num [1]	Ball Name [2] PADCFG Register [15] PADCFG Address [16]	Signal Name [3]	Mux Mode [4]	Signal Type [5]	I/O Voltage [6]	Ball State DURING Reset (RX/TX/PULL) [7]	Ball State AFTER Reset (RX/TX/PULL) [8]	Mux Mode AFTER Reset [9]	Pull Type [10]	Power [11]	Hys [12]	Voltage Buffer Type [13]	IO RET [14]
AD37	P33	MCASP2_ACLKX PADCFG: PADCONFIG_21 0x0011C054	MCAN8_RX	0	I	1.8 V/3.3 V	Off / Off / Off	Off / Off / Off	7	PU/PD	VDDSHV2	Yes	LVCMOS	Yes
			MCASP2_ACLKX	1	IO									
			VOUT0_DATA8	2	O									
			VOUT0_DATA20	5	O									
			GPMC0_AD10	6	IO									
			GPIO0_21	7	IO									
			SPI5_CS2	8	IO									
			EQEP2_S	9	IO									
			TRC_DATA4	10	O									
			UART1_RXD	11	I									
			SPI7_CS1	13	IO									
			SYNC3_OUT	14	O									
AE37	G32	MCASP2_AFSX PADCFG: PADCONFIG_22 0x0011C058	MCAN9_TX	0	O	1.8 V/3.3 V	Off / Off / Off	Off / Off / Off	7	PU/PD	VDDSHV2	Yes	LVCMOS	Yes
			MCASP2_AFSX	1	IO									
			VOUT0_DATA7	2	O									
			MDIO1_MDC	4	O									
			GPMC0_AD11	6	IO									
			GPIO0_22	7	IO									
			SPI5_CS3	8	IO									
			EHRPWM_SOC_A	9	O									
			TRC_DATA9	10	O									
			UART1_TXD	11	O									
SPI7_CS2	13	IO												
AF37	F32	MCASP0_AXR0 PADCFG: PADCONFIG_16 0x0011C040	MCAN6_TX	0	O	1.8 V/3.3 V	Off / Off / Off	Off / Off / Off	7	PU/PD	VDDSHV2	Yes	LVCMOS	Yes
			MCASP0_AXR0	1	IO									
			VOUT0_DATA13	2	O									
			GPMC0_AD2	6	IO									
			GPIO0_16	7	IO									
			SPI2_CS2	8	IO									
			EHRPWM2_A	9	IO									
			TRC_DATA14	10	O									
			UART4_RXD	11	I									
			SPI7_CLK	13	IO									
UART8_CTSn	14	I												

Table 5-1. Pin Attributes (ALY, AND Packages) (continued)

ALY Ball Num [1]	AND Ball Num [1]	Ball Name [2] PADCFG Register [15] PADCFG Address [16]	Signal Name [3]	Mux Mode [4]	Signal Type [5]	I/O Voltage [6]	Ball State DURING Reset (RX/TX/PULL) [7]	Ball State AFTER Reset (RX/TX/PULL) [8]	Mux Mode AFTER Reset [9]	Pull Type [10]	Power [11]	Hys [12]	Voltage Buffer Type [13]	IO RET [14]
AG37	H32	MCASP0_AXR1 PADCFG: PADCONFIG_17 0x0011C044	MCAN6_RX	0	I	1.8 V/3.3 V	Off / Off / Off	Off / Off / Off	7	PU/PD	VDDSHV2	Yes	LVCMOS	Yes
			MCASP0_AXR1	1	IO									
			VOUT0_DATA12	2	O									
			OBSCLK1	4	O									
			GPMC0_AD3	6	IO									
			GPIO0_17	7	IO									
			SPI2_CS3	8	IO									
			EHRPWM0_SYNCO	9	O									
			TRC_DATA12	10	O									
			UART4_TXD	11	O									
			SPI7_CS0	13	IO									
			UART8_RTSn	14	O									
AK33	H33	MCASP0_AXR2 PADCFG: PADCONFIG_18 0x0011C048	MCAN7_TX	0	O	1.8 V/3.3 V	Off / Off / Off	Off / Off / Off	7	PU/PD	VDDSHV2	Yes	LVCMOS	Yes
			MCASP0_AXR2	1	IO									
			VOUT0_DATA11	2	O									
			GPMC0_ADVn_ALE	6	O									
			GPIO0_18	7	IO									
			EQEP2_A	9	I									
			TRC_DATA10	10	O									
			UART4_CTSn	11	I									
			GPMC0_WPn	12	O									
			UART9_CTSn	13	I									
AJ38	F31	MCASP0_AXR3 PADCFG: PADCONFIG_31 0x0011C07C	MCAN3_TX	0	O	1.8 V/3.3 V	Off / Off / Off	Off / Off / Off	7	PU/PD	VDDSHV2	Yes	LVCMOS	Yes
			MCASP0_AXR3	1	IO									
			VOUT0_DATA2	2	O									
			GPMC0_BE1n	6	O									
			GPIO0_31	7	IO									
			SPI5_CLK	8	IO									
			EHRPWM_TZn_IN0	9	I									
			TRC_DATA7	10	O									
			UART3_CTSn	11	I									
			SPI3_CS1	12	IO									
SPI7_D1	13	IO												

Table 5-1. Pin Attributes (ALY, AND Packages) (continued)

ALY Ball Num [1]	AND Ball Num [1]	Ball Name [2] PADCFG Register [15] PADCFG Address [16]	Signal Name [3]	Mux Mode [4]	Signal Type [5]	I/O Voltage [6]	Ball State DURING Reset (RX/TX/PULL) [7]	Ball State AFTER Reset (RX/TX/PULL) [8]	Mux Mode AFTER Reset [9]	Pull Type [10]	Power [11]	Hys [12]	Voltage Buffer Type [13]	IO RET [14]
AK34	J32	MCASP0_AXR4 PADCFG: PADCONFIG_32 0x0011C080	MCAN3_RX	0	I	1.8 V/3.3 V	Off / Off / Off	Off / Off / Off	7	PU/PD	VDDSHV2	Yes	LVCMOS	Yes
			MCASP0_AXR4	1	IO									
			VOUT0_HSYNC	2	O									
			VOUT0_VP0_HSYNC	4	O									
			VOUT0_VP2_HSYNC	5	O									
			GPMC0_OE_n_REn	6	O									
			GPIO0_32	7	IO									
			SPI6_CS2	8	IO									
			EHRPWM5_B	9	IO									
			TRC_DATA18	10	O									
AG38	H30	MCASP0_AXR5 PADCFG: PADCONFIG_33 0x0011C084	MCAN4_TX	0	O	1.8 V/3.3 V	Off / Off / Off	Off / Off / Off	7	PU/PD	VDDSHV2	Yes	LVCMOS	Yes
			MCASP0_AXR5	1	IO									
			VOUT0_DE	2	O									
			MCASP1_ACLKR	3	IO									
			VOUT0_VP0_DE	4	O									
			VOUT0_VP2_DE	5	O									
			GPMC0_CSn0	6	O									
			GPIO0_33	7	IO									
			SPI6_CS3	8	IO									
			EHRPWM5_A	9	IO									
TRC_DATA19	10	O												
AF36	K33	MCASP0_AXR6 PADCFG: PADCONFIG_34 0x0011C088	MCAN4_RX	0	I	1.8 V/3.3 V	Off / Off / Off	Off / Off / Off	7	PU/PD	VDDSHV2	Yes	LVCMOS	Yes
			MCASP0_AXR6	1	IO									
			VOUT0_VSYNC	2	O									
			MCASP1_AFSR	3	IO									
			VOUT0_VP0_VSYNC	4	O									
			VOUT0_VP2_VSYNC	5	O									
			GPMC0_CLKOUT	6	O									
			GPIO0_34	7	IO									
			SPI3_CS2	8	IO									
			EHRPWM_TZn_IN4	9	I									
TRC_DATA20	10	O												
SPI5_D1	11	IO												
GPMC0_FCLK_MUX	12	O												

Table 5-1. Pin Attributes (ALY, AND Packages) (continued)

ALY Ball Num [1]	AND Ball Num [1]	Ball Name [2] PADCFG Register [15] PADCFG Address [16]	Signal Name [3]	Mux Mode [4]	Signal Type [5]	I/O Voltage [6]	Ball State DURING Reset (RX/TX/PULL) [7]	Ball State AFTER Reset (RX/TX/PULL) [8]	Mux Mode AFTER Reset [9]	Pull Type [10]	Power [11]	Hys [12]	Voltage Buffer Type [13]	IO RET [14]
AE35	M31	MCASP0_AXR7 PADCFG: PADCONFIG_35 0x0011C08C	MCAN5_TX	0	O	1.8 V/3.3 V	Off / Off / Off	Off / Off / Off	7	PU/PD	VDDSHV2	Yes	LVCMOS	Yes
			MCASP0_AXR7	1	IO									
			MCASP4_ACLKR	3	IO									
			GPMC0_A0	5	OZ									
			RGMI1_TD0	6	O									
			GPIO0_35	7	IO									
			GPMC0_A14	8	OZ									
			EHRPWM3_A	9	IO									
			UART4_RXD	11	I									
			GPMC0_CSn2	12	O									
USB0_DRVVBUS	14	O												
AC35	N30	MCASP0_AXR8 PADCFG: PADCONFIG_36 0x0011C090	MCAN5_RX	0	I	1.8 V/3.3 V	Off / Off / Off	Off / Off / Off	7	PU/PD	VDDSHV2	Yes	LVCMOS	Yes
			MCASP0_AXR8	1	IO									
			MCASP4_AFSR	3	IO									
			GPMC0_A1	5	OZ									
			RGMI1_TD1	6	O									
			GPIO0_36	7	IO									
			RMII1_RXD0	8	I									
			EHRPWM_TZn_IN3	9	I									
			UART4_TXD	11	O									
AG35	T33	MCASP0_AXR9 PADCFG: PADCONFIG_37 0x0011C094	MCAN6_TX	0	O	1.8 V/3.3 V	Off / Off / Off	Off / Off / Off	7	PU/PD	VDDSHV2	Yes	LVCMOS	Yes
			MCASP0_AXR9	1	IO									
			MCASP4_AXR4	2	IO									
			GPMC0_A2	5	OZ									
			RGMI1_TD2	6	O									
			GPIO0_37	7	IO									
			RMII1_RXD1	8	I									
			EHRPWM3_SYNCO	9	O									
UART4_CTSn	11	I												
AH36	L32	MCASP0_AXR10 PADCFG: PADCONFIG_38 0x0011C098	MCAN6_RX	0	I	1.8 V/3.3 V	Off / Off / Off	Off / Off / Off	7	PU/PD	VDDSHV2	Yes	LVCMOS	Yes
			MCASP0_AXR10	1	IO									
			GPMC0_A3	5	OZ									
			RGMI1_TD3	6	O									
			GPIO0_38	7	IO									
			RMII1_CRS_DV	8	I									
			EHRPWM3_SYNCI	9	I									
			UART4_RTSn	11	O									

Table 5-1. Pin Attributes (ALY, AND Packages) (continued)

ALY Ball Num [1]	AND Ball Num [1]	Ball Name [2] PADCFG Register [15] PADCFG Address [16]	Signal Name [3]	Mux Mode [4]	Signal Type [5]	I/O Voltage [6]	Ball State DURING Reset (RX/TX/PULL) [7]	Ball State AFTER Reset (RX/TX/PULL) [8]	Mux Mode AFTER Reset [9]	Pull Type [10]	Power [11]	Hys [12]	Voltage Buffer Type [13]	IO RET [14]
AF35	P30	MCASP0_AXR11 PADCFG: PADCONFIG_39 0x0011C09C	MCAN7_TX	0	O	1.8 V/3.3 V	Off / Off / Off	Off / Off / Off	7	PU/PD	VDDSHV2	Yes	LVCMOS	Yes
			MCASP0_AXR11	1	IO									
			DSS_FSYNC2	4	O									
			GPMC0_A4	5	OZ									
			RGMII1_TX_CTL	6	O									
			GPIO0_39	7	IO									
			RMII1_RX_ER	8	I									
			EHRPWM3_B	9	IO									
			SPI2_CS1	10	IO									
UART5_RXD	11	I												
AD34	M32	MCASP0_AXR12 PADCFG: PADCONFIG_40 0x0011C0A0	MCAN7_RX	0	I	1.8 V/3.3 V	Off / Off / Off	Off / Off / Off	7	PU/PD	VDDSHV2	Yes	LVCMOS	Yes
			MCASP0_AXR12	1	IO									
			MCASP2_ACLKR	3	IO									
			DSS_FSYNC3	4	O									
			GPMC0_A5	5	OZ									
			RGMII1_RD1	6	I									
			GPIO0_40	7	IO									
			RMII1_TXD0	8	O									
			EHRPWM_SOCB	9	O									
			SPI2_CLK	10	IO									
			UART5_TXD	11	O									
AJ36	L33	MCASP0_AXR13 PADCFG: PADCONFIG_41 0x0011C0A4	MCAN8_TX	0	O	1.8 V/3.3 V	Off / Off / Off	Off / Off / Off	7	PU/PD	VDDSHV2	Yes	LVCMOS	Yes
			MCASP0_AXR13	1	IO									
			MCASP2_AFSR	3	IO									
			GPMC0_A6	5	OZ									
			RGMII1_RD2	6	I									
			GPIO0_41	7	IO									
			RMII_REF_CLK	8	I									
			EHRPWM4_A	9	IO									
			SPI2_CS0	10	IO									
			UART5_CTSn	11	I									
UART7_RXD	13	I												

Table 5-1. Pin Attributes (ALY, AND Packages) (continued)

ALY Ball Num [1]	AND Ball Num [1]	Ball Name [2] PADCFG Register [15] PADCFG Address [16]	Signal Name [3]	Mux Mode [4]	Signal Type [5]	I/O Voltage [6]	Ball State DURING Reset (RX/TX/PULL) [7]	Ball State AFTER Reset (RX/TX/PULL) [8]	Mux Mode AFTER Reset [9]	Pull Type [10]	Power [11]	Hys [12]	Voltage Buffer Type [13]	IO RET [14]
AF34	U31	MCASP0_AXR14 PADCFG: PADCONFIG_42 0x0011C0A8	MCAN8_RX	0	I	1.8 V/3.3 V	Off / Off / Off	Off / Off / Off	7	PU/PD	VDDSHV2	Yes	LVCMOS	Yes
			MCASP0_AXR14	1	IO									
			MCASP2_AXR4	2	IO									
			MCASP0_ACLKR	3	IO									
			GPMC0_A7	5	OZ									
			RGMI1_RD3	6	I									
			GPIO0_42	7	IO									
			CLKOUT	8	IO									
			EQEP0_A	9	I									
			SPI2_D0	10	IO									
			UART5_RTSn	11	O									
			UART7_TXD	13	O									
AE34	M33	MCASP0_AXR15 PADCFG: PADCONFIG_43 0x0011C0AC	MCAN9_TX	0	O	1.8 V/3.3 V	Off / Off / Off	Off / Off / Off	7	PU/PD	VDDSHV2	Yes	LVCMOS	Yes
			MCASP0_AXR15	1	IO									
			MCASP0_AFSR	3	IO									
			GPMC0_A8	5	OZ									
			RGMI1_RX_CTL	6	I									
			GPIO0_43	7	IO									
			RMII1_TX_EN	8	O									
			EQEP0_B	9	I									
			SPI2_D1	10	IO									
			UART8_RXD	11	I									
			I2C1_SCL	13	IOD									
			AD38	H29	MCASP1_AXR0 PADCFG: PADCONFIG_48 0x0011C0C0									
MCASP1_AXR0	1	IO												
GPMC0_A13	5	OZ												
MDIO0_MDC	6	O												
GPIO0_48	7	IO												
SPI3_CLK	8	IO												
EQEP1_S	9	IO												
UART0_TXD	11	O												
GPMC0_WAIT3	12	I												
SYNC2_OUT	14	O												

Table 5-1. Pin Attributes (ALY, AND Packages) (continued)

ALY Ball Num [1]	AND Ball Num [1]	Ball Name [2] PADCFG Register [15] PADCFG Address [16]	Signal Name [3]	Mux Mode [4]	Signal Type [5]	I/O Voltage [6]	Ball State DURING Reset (RX/TX/PULL) [7]	Ball State AFTER Reset (RX/TX/PULL) [8]	Mux Mode AFTER Reset [9]	Pull Type [10]	Power [11]	Hys [12]	Voltage Buffer Type [13]	IO RET [14]
AC32	G31	MCASP1_AXR1 PADCFG: PADCONFIG_19 0x0011C04C	MCAN7_RX	0	I	1.8 V/3.3 V	Off / Off / Off	Off / Off / Off	7	PU/PD	VDDSHV2	Yes	LVCMOS	Yes
			MCASP1_AXR1	1	IO									
			VOUT0_DATA10	2	O									
			GPMC0_AD8	6	IO									
			GPIO0_19	7	IO									
			SPI3_D0	8	IO									
			EHRPWM_TZn_IN1	9	I									
			TRC_DATA8	10	O									
			UART0_CTSn	11	I									
			UART9_RXD	12	I									
			I2C2_SCL	13	IOD									
AC37	J31	MCASP1_AXR2 PADCFG: PADCONFIG_20 0x0011C050	MCAN8_TX	0	O	1.8 V/3.3 V	Off / Off / Off	Off / Off / Off	7	PU/PD	VDDSHV2	Yes	LVCMOS	Yes
			MCASP1_AXR2	1	IO									
			VOUT0_DATA9	2	O									
			VOUT0_DATA21	5	O									
			GPMC0_AD9	6	IO									
			GPIO0_20	7	IO									
			SPI3_D1	8	IO									
			EQEP2_B	9	I									
			TRC_DATA6	10	O									
			UART0_RTSn	11	O									
			UART9_TXD	12	O									
I2C2_SDA	13	IOD												
AL33	P31	MCASP1_AXR3 PADCFG: PADCONFIG_44 0x0011C0B0	MCAN9_RX	0	I	1.8 V/3.3 V	Off / Off / Off	Off / Off / Off	7	PU/PD	VDDSHV2	Yes	LVCMOS	Yes
			MCASP1_AXR3	1	IO									
			PCIE2_CLKREQn	4	IO									
			GPMC0_A9	5	OZ									
			RGMI1_RXC	6	I									
			GPIO0_44	7	IO									
			RMII1_TXD1	8	O									
			EQEP1_A	9	I									
UART8_TXD	11	O												
I2C1_SDA	13	IOD												

Table 5-1. Pin Attributes (ALY, AND Packages) (continued)

ALY Ball Num [1]	AND Ball Num [1]	Ball Name [2] PADCFG Register [15] PADCFG Address [16]	Signal Name [3]	Mux Mode [4]	Signal Type [5]	I/O Voltage [6]	Ball State DURING Reset (RX/TX/PULL) [7]	Ball State AFTER Reset (RX/TX/PULL) [8]	Mux Mode AFTER Reset [9]	Pull Type [10]	Power [11]	Hys [12]	Voltage Buffer Type [13]	IO RET [14]
AL34	N31	MCASP1_AXR4 PADCFG: PADCONFIG_45 0x0011C0B4	MCAN10_TX	0	O	1.8 V/3.3 V	Off / Off / Off	Off / Off / Off	7	PU/PD	VDDSHV2	Yes	LVCMOS	Yes
			MCASP1_AXR4	1	IO									
			PCIE3_CLKREQn	4	IO									
			GPMC0_A10	5	OZ									
			RGMI1_TXC	6	O									
			GPIO0_45	7	IO									
			EQEP1_B	9	I									
UART4_RXD	11	I												
AC36	K32	MCASP2_AXR0 PADCFG: PADCONFIG_23 0x0011C05C	MCAN9_RX	0	I	1.8 V/3.3 V	Off / Off / Off	Off / Off / Off	7	PU/PD	VDDSHV2	Yes	LVCMOS	Yes
			MCASP2_AXR0	1	IO									
			VOUT0_DATA6	2	O									
			MDIO1_MDIO	4	IO									
			GPMC0_AD12	6	IO									
			GPIO0_23	7	IO									
			EQEP2_I	9	IO									
			TRC_DATA15	10	O									
			UART1_CTSn	11	I									
UART6_RXD	12	I												
AE36	R32	MCASP2_AXR1 PADCFG: PADCONFIG_24 0x0011C060	MCAN17_RX	0	I	1.8 V/3.3 V	Off / Off / Off	Off / Off / Off	7	PU/PD	VDDSHV2	Yes	LVCMOS	Yes
			MCASP2_AXR1	1	IO									
			VOUT0_DATA5	2	O									
			GPMC0_AD13	6	IO									
			GPIO0_24	7	IO									
			EHRPWM1_A	9	IO									
			TRC_DATA13	10	O									
			UART1_RTSn	11	O									
			UART6_TXD	12	O									
I2C3_SDA	13	IOD												
U35	C26	MCU_ADC0_REFN	MCU_ADC0_REFN		A	1.8 V				VDDA_ADC0			ADC12B	No
R35	D25	MCU_ADC0_REFP	MCU_ADC0_REFP		A	1.8 V				VDDA_ADC0			ADC12B	No
W35	D29	MCU_ADC1_REFN	MCU_ADC1_REFN		A	1.8 V				VDDA_ADC1			ADC12B	No
AA35	C30	MCU_ADC1_REFP	MCU_ADC1_REFP		A	1.8 V				VDDA_ADC1			ADC12B	No
P36	E26	MCU_ADC0_AIN0 PADCFG: WKUP_PADCONFIG_77 0x4301C134	WKUP_GPIO0_71	- (1)	I	1.8 V			0		VDDA_ADC0		ADC12B	No
			MCU_ADC0_AIN0	0	A									

Table 5-1. Pin Attributes (ALY, AND Packages) (continued)

ALY Ball Num [1]	AND Ball Num [1]	Ball Name [2] PADCFG Register [15] PADCFG Address [16]	Signal Name [3]	Mux Mode [4]	Signal Type [5]	I/O Voltage [6]	Ball State DURING Reset (RX/TX/PULL) [7]	Ball State AFTER Reset (RX/TX/PULL) [8]	Mux Mode AFTER Reset [9]	Pull Type [10]	Power [11]	Hys [12]	Voltage Buffer Type [13]	IO RET [14]
V36	F25	MCU_ADC0_AIN1 PADCFG: WKUP_PADCONFIG_78 0x4301C138	WKUP_GPIO0_72	-(1)	I	1.8 V			0		VDDA_ADC0		ADC12B	No
			MCU_ADC0_AIN1	0	A									
T34	F23	MCU_ADC0_AIN2 PADCFG: WKUP_PADCONFIG_79 0x4301C13C	MCU_ADC0_AIN2	0	A	1.8 V			0		VDDA_ADC0		ADC12B	No
			WKUP_GPIO0_73	-(1)	I									
T36	A28	MCU_ADC0_AIN3 PADCFG: WKUP_PADCONFIG_80 0x4301C140	MCU_ADC0_AIN3	0	A	1.8 V			0		VDDA_ADC0		ADC12B	No
			WKUP_GPIO0_74	-(1)	I									
P34	E24	MCU_ADC0_AIN4 PADCFG: WKUP_PADCONFIG_81 0x4301C144	WKUP_GPIO0_75	-(1)	I	1.8 V			0		VDDA_ADC0		ADC12B	No
			MCU_ADC0_AIN4	0	A									
R37	D27	MCU_ADC0_AIN5 PADCFG: WKUP_PADCONFIG_82 0x4301C148	MCU_ADC0_AIN5	0	A	1.8 V			0		VDDA_ADC0		ADC12B	No
			WKUP_GPIO0_76	-(1)	I									
R33	A26	MCU_ADC0_AIN6 PADCFG: WKUP_PADCONFIG_83 0x4301C14C	WKUP_GPIO0_77	-(1)	I	1.8 V			0		VDDA_ADC0		ADC12B	No
			MCU_ADC0_AIN6	0	A									
V38	B27	MCU_ADC0_AIN7 PADCFG: WKUP_PADCONFIG_84 0x4301C150	MCU_ADC0_AIN7	0	A	1.8 V			0		VDDA_ADC0		ADC12B	No
			WKUP_GPIO0_78	-(1)	I									
Y38	C32	MCU_ADC1_AIN0 PADCFG: WKUP_PADCONFIG_85 0x4301C154	WKUP_GPIO0_79	-(1)	I	1.8 V			0		VDDA_ADC1		ADC12B	No
			MCU_ADC1_AIN0	0	A									
Y34	B33	MCU_ADC1_AIN1 PADCFG: WKUP_PADCONFIG_86 0x4301C158	WKUP_GPIO0_80	-(1)	I	1.8 V			0		VDDA_ADC1		ADC12B	No
			MCU_ADC1_AIN1	0	A									
V34	B31	MCU_ADC1_AIN2 PADCFG: WKUP_PADCONFIG_87 0x4301C15C	WKUP_GPIO0_81	-(1)	I	1.8 V			0		VDDA_ADC1		ADC12B	No
			MCU_ADC1_AIN2	0	A									
W37	B29	MCU_ADC1_AIN3 PADCFG: WKUP_PADCONFIG_88 0x4301C160	MCU_ADC1_AIN3	0	A	1.8 V			0		VDDA_ADC1		ADC12B	No
			WKUP_GPIO0_82	-(1)	I									

Table 5-1. Pin Attributes (ALY, AND Packages) (continued)

ALY Ball Num [1]	AND Ball Num [1]	Ball Name [2] PADCFG Register [15] PADCFG Address [16]	Signal Name [3]	Mux Mode [4]	Signal Type [5]	I/O Voltage [6]	Ball State DURING Reset (RX/TX/PULL) [7]	Ball State AFTER Reset (RX/TX/PULL) [8]	Mux Mode AFTER Reset [9]	Pull Type [10]	Power [11]	Hys [12]	Voltage Buffer Type [13]	IO RET [14]
AA37	D31	MCU_ADC1_AIN4 PADCFG: WKUP_PADCONFIG_89 0x4301C164	WKUP_GPIO0_83	-(1)	I	1.8 V			0		VDDA_ADC1		ADC12B	No
			MCU_ADC1_AIN4	0	A									
W33	A32	MCU_ADC1_AIN5 PADCFG: WKUP_PADCONFIG_90 0x4301C168	MCU_ADC1_AIN5	0	A	1.8 V			0		VDDA_ADC1		ADC12B	No
			WKUP_GPIO0_84	-(1)	I									
U33	A30	MCU_ADC1_AIN6 PADCFG: WKUP_PADCONFIG_91 0x4301C16C	WKUP_GPIO0_85	-(1)	I	1.8 V			0		VDDA_ADC1		ADC12B	No
			MCU_ADC1_AIN6	0	A									
Y36	C28	MCU_ADC1_AIN7 PADCFG: WKUP_PADCONFIG_92 0x4301C170	WKUP_GPIO0_86	-(1)	I	1.8 V			0		VDDA_ADC1		ADC12B	No
			MCU_ADC1_AIN7	0	A									
M35	D22	MCU_I2C0_SCL PADCFG: WKUP_PADCONFIG_66 0x4301C108	MCU_I2C0_SCL	0	IOD	1.8 V/3.3 V	Off / Off / Off	On / SS / Off	0		VDDSHV0_MCU	Yes	I2C OPEN DRAIN	Yes
			WKUP_GPIO0_65	7	IO									
G34	A21	MCU_I2C0_SDA PADCFG: WKUP_PADCONFIG_67 0x4301C10C	MCU_I2C0_SDA	0	IOD	1.8 V/3.3 V	Off / Off / Off	On / SS / Off	0		VDDSHV0_MCU	Yes	I2C OPEN DRAIN	Yes
			WKUP_GPIO0_87	7	IO									
F38	C18	MCU_MCAN0_RX PADCFG: WKUP_PADCONFIG_47 0x4301C0BC	MCU_MCAN0_RX	0	I	1.8 V/3.3 V	Off / Off / Off	Off / Off / Off	7	PU/PD	VDDSHV0_MCU	Yes	LVCMOS	Yes
			WKUP_GPIO0_61	7	IO									
K33	E22	MCU_MCAN0_TX PADCFG: WKUP_PADCONFIG_46 0x4301C0B8	MCU_MCAN0_TX	0	O	1.8 V/3.3 V	Off / Off / Off	Off / Off / Off	7	PU/PD	VDDSHV0_MCU	Yes	LVCMOS	Yes
			WKUP_GPIO0_60	7	IO									
A36	E12	MCU_MDIO0_MDC PADCFG: WKUP_PADCONFIG_39 0x4301C09C	MCU_MDIO0_MDC	0	O	1.8 V/3.3 V	Off / Off / Off	Off / Off / Off	7	PU/PD	VDDSHV2_MCU	Yes	LVCMOS	No
			WKUP_GPIO0_53	7	IO									
B35	F13	MCU_MDIO0_MDIO PADCFG: WKUP_PADCONFIG_38 0x4301C098	MCU_MDIO0_MDIO	0	IO	1.8 V/3.3 V	Off / Off / Off	Off / Off / Off	7	PU/PD	VDDSHV2_MCU	Yes	LVCMOS	No
			WKUP_GPIO0_52	7	IO									
E32	D8	MCU_OSPI0_CLK PADCFG: WKUP_PADCONFIG_0 0x4301C000	MCU_OSPI0_CLK	0	O	1.8 V/3.3 V	Off / Off / Off	Off / Off / Off	7	PU/PD	VDDSHV1_MCU	Yes	LVCMOS	No
			MCU_HYPERBUS0_CK	1	O									
			WKUP_GPIO0_16	7	IO									

Table 5-1. Pin Attributes (ALY, AND Packages) (continued)

ALY Ball Num [1]	AND Ball Num [1]	Ball Name [2] PADCFG Register [15] PADCFG Address [16]	Signal Name [3]	Mux Mode [4]	Signal Type [5]	I/O Voltage [6]	Ball State DURING Reset (RX/TX/PULL) [7]	Ball State AFTER Reset (RX/TX/PULL) [8]	Mux Mode AFTER Reset [9]	Pull Type [10]	Power [11]	Hys [12]	Voltage Buffer Type [13]	IO RET [14]
C34	C10	MCU_OSPI0_DQS PADCFG: WKUP_PADCONFIG_2 0x4301C008	MCU_OSPI0_DQS	0	I	1.8 V/3.3 V	Off / Off / Off	Off / Off / Off	7	PU/PD	VDDSHV1_MCU	Yes	LVCMOS	No
			MCU_HYPERBUS0_RWDS	1	IO									
			WKUP_GPIO0_18	7	IO									
D32	D10	MCU_OSPI0_LBCLKO PADCFG: WKUP_PADCONFIG_1 0x4301C004	MCU_OSPI0_LBCLKO	0	IO	1.8 V/3.3 V	Off / Off / Off	On / Off / Off	7	PU/PD	VDDSHV1_MCU	Yes	LVCMOS	No
			MCU_HYPERBUS0_CKn	1	O									
			WKUP_GPIO0_17	7	IO									
F32	B7	MCU_OSPI1_CLK PADCFG: WKUP_PADCONFIG_16 0x4301C040	MCU_OSPI1_CLK	0	O	1.8 V/3.3 V	Off / Off / Off	Off / Off / Off	7	PU/PD	VDDSHV1_MCU	Yes	LVCMOS	No
			WKUP_GPIO0_31	7	IO									
F31	B9	MCU_OSPI1_DQS PADCFG: WKUP_PADCONFIG_18 0x4301C048	MCU_OSPI1_DQS	0	I	1.8 V/3.3 V	Off / Off / Off	Off / Off / Off	7	PU/PD	VDDSHV1_MCU	Yes	LVCMOS	No
			MCU_OSPI0_CSn3	1	O									
			MCU_HYPERBUS0_INTn	2	I									
			MCU_OSPI0_ECC_FAIL	6	I									
C31	B10	MCU_OSPI1_LBCLKO PADCFG: WKUP_PADCONFIG_17 0x4301C044	MCU_OSPI1_LBCLKO	0	IO	1.8 V/3.3 V	Off / Off / Off	On / Off / Off	7	PU/PD	VDDSHV1_MCU	Yes	LVCMOS	No
			MCU_OSPI0_CSn2	1	O									
			MCU_HYPERBUS0_RESETOh	2	I									
			MCU_OSPI0_RESET_OUT0	6	O									
A32	F12	MCU_OSPI0_CSn0 PADCFG: WKUP_PADCONFIG_11 0x4301C02C	MCU_OSPI0_CSn0	0	O	1.8 V/3.3 V	Off / Off / Off	Off / Off / Off	7	PU/PD	VDDSHV1_MCU	Yes	LVCMOS	No
			MCU_HYPERBUS0_CSn0	1	O									
			WKUP_GPIO0_27	7	IO									
A33	F11	MCU_OSPI0_CSn1 PADCFG: WKUP_PADCONFIG_12 0x4301C030	MCU_OSPI0_CSn1	0	O	1.8 V/3.3 V	Off / Off / Off	Off / Off / Off	7	PU/PD	VDDSHV1_MCU	Yes	LVCMOS	No
			MCU_HYPERBUS0_RESETOh	1	O									
			WKUP_GPIO0_28	7	IO									
B34	F10	MCU_OSPI0_CSn2 PADCFG: WKUP_PADCONFIG_14 0x4301C038	MCU_OSPI0_CSn2	0	O	1.8 V/3.3 V	Off / Off / Off	Off / Off / Off	7	PU/PD	VDDSHV1_MCU	Yes	LVCMOS	No
			MCU_OSPI0_CSn2	1	O									
			MCU_HYPERBUS0_RESETOh	2	I									
			MCU_HYPERBUS0_WPn	3	O									
			MCU_HYPERBUS0_CSn1	4	O									
			MCU_OSPI0_RESET_OUT0	6	O									
WKUP_GPIO0_29	7	IO												

Table 5-1. Pin Attributes (ALY, AND Packages) (continued)

ALY Ball Num [1]	AND Ball Num [1]	Ball Name [2] PADCFG Register [15] PADCFG Address [16]	Signal Name [3]	Mux Mode [4]	Signal Type [5]	I/O Voltage [6]	Ball State DURING Reset (RX/TX/PULL) [7]	Ball State AFTER Reset (RX/TX/PULL) [8]	Mux Mode AFTER Reset [9]	Pull Type [10]	Power [11]	Hys [12]	Voltage Buffer Type [13]	IO RET [14]
C32	E11	MCU_OSPI0_CSn3 PADCFG: WKUP_PADCONFIG_15 0x4301C03C	MCU_OSPI0_CSn3	0	O	1.8 V/3.3 V	Off / Off / Off	Off / Off / Off	7	PU/PD	VDDSHV1_MCU	Yes	LVCMOS	No
			MCU_OSPI0_CSn3	1	O									
			MCU_HYPERBUS0_INTn	2	I									
			MCU_HYPERBUS0_WPn	3	O									
			MCU_OSPI0_RESET_OUT1	5	O									
			MCU_OSPI0_ECC_FAIL	6	I									
			WKUP_GPIO0_30	7	IO									
B33	E10	MCU_OSPI0_D0 PADCFG: WKUP_PADCONFIG_3 0x4301C00C	MCU_OSPI0_D0	0	IO	1.8 V/3.3 V	On / Off / Off	On / Off / Off	7	PU/PD	VDDSHV1_MCU	Yes	LVCMOS	No
			MCU_HYPERBUS0_DQ0	1	IO									
			WKUP_GPIO0_19	7	IO									
			BOOTMODE00		BOOTS TRAP									
B32	F9	MCU_OSPI0_D1 PADCFG: WKUP_PADCONFIG_4 0x4301C010	MCU_OSPI0_D1	0	IO	1.8 V/3.3 V	On / Off / Off	On / Off / Off	7	PU/PD	VDDSHV1_MCU	Yes	LVCMOS	No
			MCU_HYPERBUS0_DQ1	1	IO									
			WKUP_GPIO0_20	7	IO									
			BOOTMODE01		BOOTS TRAP									
C33	E9	MCU_OSPI0_D2 PADCFG: WKUP_PADCONFIG_5 0x4301C014	MCU_OSPI0_D2	0	IO	1.8 V/3.3 V	Off / Off / Off	Off / Off / Off	7	PU/PD	VDDSHV1_MCU	Yes	LVCMOS	No
			MCU_HYPERBUS0_DQ2	1	IO									
			WKUP_GPIO0_21	7	IO									
C35	D11	MCU_OSPI0_D3 PADCFG: WKUP_PADCONFIG_6 0x4301C018	MCU_OSPI0_D3	0	IO	1.8 V/3.3 V	Off / Off / Off	Off / Off / Off	7	PU/PD	VDDSHV1_MCU	Yes	LVCMOS	No
			MCU_HYPERBUS0_DQ3	1	IO									
			WKUP_GPIO0_22	7	IO									
D33	D9	MCU_OSPI0_D4 PADCFG: WKUP_PADCONFIG_7 0x4301C01C	MCU_OSPI0_D4	0	IO	1.8 V/3.3 V	On / Off / Off	On / Off / Off	7	PU/PD	VDDSHV1_MCU	Yes	LVCMOS	No
			MCU_HYPERBUS0_DQ4	1	IO									
			WKUP_GPIO0_23	7	IO									
			BOOTMODE02		BOOTS TRAP									
D34	C9	MCU_OSPI0_D5 PADCFG: WKUP_PADCONFIG_8 0x4301C020	MCU_OSPI0_D5	0	IO	1.8 V/3.3 V	On / Off / Off	On / Off / Off	7	PU/PD	VDDSHV1_MCU	Yes	LVCMOS	No
			MCU_HYPERBUS0_DQ5	1	IO									
			WKUP_GPIO0_24	7	IO									
			BOOTMODE03		BOOTS TRAP									
E34	C7	MCU_OSPI0_D6 PADCFG: WKUP_PADCONFIG_9 0x4301C024	MCU_OSPI0_D6	0	IO	1.8 V/3.3 V	Off / Off / Off	Off / Off / Off	7	PU/PD	VDDSHV1_MCU	Yes	LVCMOS	No
			MCU_HYPERBUS0_DQ6	1	IO									
			WKUP_GPIO0_25	7	IO									

Table 5-1. Pin Attributes (ALY, AND Packages) (continued)

ALY Ball Num [1]	AND Ball Num [1]	Ball Name [2] PADCFG Register [15] PADCFG Address [16]	Signal Name [3]	Mux Mode [4]	Signal Type [5]	I/O Voltage [6]	Ball State DURING Reset (RX/TX/PULL) [7]	Ball State AFTER Reset (RX/TX/PULL) [8]	Mux Mode AFTER Reset [9]	Pull Type [10]	Power [11]	Hys [12]	Voltage Buffer Type [13]	IO RET [14]
E33	C8	MCU_OSPI0_D7 PADCFG: WKUP_PADCONFIG_10 0x4301C028	MCU_OSPI0_D7	0	IO	1.8 V/3.3 V	Off / Off / Off	Off / Off / Off	7	PU/PD	VDDSHV1_MCU	Yes	LVCMOS	No
			MCU_HYPERBUS0_DQ7	1	IO									
			WKUP_GPIO0_26	7	IO									
G32	A8	MCU_OSPI1_CSn0 PADCFG: WKUP_PADCONFIG_23 0x4301C05C	MCU_OSPI1_CSn0	0	O	1.8 V/3.3 V	Off / Off / Off	Off / Off / Off	7	PU/PD	VDDSHV1_MCU	Yes	LVCMOS	No
			WKUP_GPIO0_38	7	IO									
G33	A9	MCU_OSPI1_CSn1 PADCFG: WKUP_PADCONFIG_24 0x4301C060	MCU_OSPI1_CSn1	0	O	1.8 V/3.3 V	Off / Off / Off	Off / Off / Off	7	PU/PD	VDDSHV1_MCU	Yes	LVCMOS	No
			MCU_HYPERBUS0_WPn	1	O									
			MCU_TIMER_IO0	2	IO									
			MCU_HYPERBUS0_CSn1	3	O									
			MCU_UART0_RTSn	4	O									
			MCU_SPI0_CS2	5	IO									
			MCU_OSPI0_RESET_OUT1	6	O									
WKUP_GPIO0_39	7	IO												
E35	B8	MCU_OSPI1_D0 PADCFG: WKUP_PADCONFIG_19 0x4301C04C	MCU_OSPI1_D0	0	IO	1.8 V/3.3 V	Off / Off / Off	Off / Off / Off	7	PU/PD	VDDSHV1_MCU	Yes	LVCMOS	No
			WKUP_GPIO0_34	7	IO									
D31	B11	MCU_OSPI1_D1 PADCFG: WKUP_PADCONFIG_20 0x4301C050	MCU_OSPI1_D1	0	IO	1.8 V/3.3 V	Off / Off / Off	Off / Off / Off	7	PU/PD	VDDSHV1_MCU	Yes	LVCMOS	No
			MCU_UART0_RXD	4	I									
			MCU_SPI1_CS1	5	IO									
			WKUP_GPIO0_35	7	IO									
G31	A11	MCU_OSPI1_D2 PADCFG: WKUP_PADCONFIG_21 0x4301C054	MCU_OSPI1_D2	0	IO	1.8 V/3.3 V	Off / Off / Off	Off / Off / Off	7	PU/PD	VDDSHV1_MCU	Yes	LVCMOS	No
			MCU_UART0_TXD	4	O									
			MCU_SPI1_CS2	5	IO									
			WKUP_GPIO0_36	7	IO									
F33	A10	MCU_OSPI1_D3 PADCFG: WKUP_PADCONFIG_22 0x4301C058	MCU_OSPI1_D3	0	IO	1.8 V/3.3 V	Off / Off / Off	Off / Off / Off	7	PU/PD	VDDSHV1_MCU	Yes	LVCMOS	No
			MCU_UART0_CTSn	4	I									
			MCU_SPI0_CS1	5	IO									
			WKUP_GPIO0_37	7	IO									
K32	C24	MCU_PORz	MCU_PORz		I	1.8 V					VDDA_WKU_P	Yes	FS_RESET	No
F36	E21	MCU_RESETSTATz PADCFG: WKUP_PADCONFIG_71 0x4301C11C	MCU_RESETSTATz	0	O	1.8 V/3.3 V	Off / Low / Off	Off / SS / Off	0	PU/PD	VDDSHV0_MCU	Yes	LVCMOS	No
			WKUP_GPIO0_68	7	IO									

Table 5-1. Pin Attributes (ALY, AND Packages) (continued)

ALY Ball Num [1]	AND Ball Num [1]	Ball Name [2] PADCFG Register [15] PADCFG Address [16]	Signal Name [3]	Mux Mode [4]	Signal Type [5]	I/O Voltage [6]	Ball State DURING Reset (RX/TX/PULL) [7]	Ball State AFTER Reset (RX/TX/PULL) [8]	Mux Mode AFTER Reset [9]	Pull Type [10]	Power [11]	Hys [12]	Voltage Buffer Type [13]	IO RET [14]
G36	E20	MCU_RESETz PADCFG: WKUP_PADCONFIG_70 0x4301C118	MCU_RESETz	0	I	1.8 V/3.3 V	On / NA / Up	On / Off / Up	0	PU/PD	VDDSHV0_MCU	Yes	LVC MOS	No
B37	C14	MCU_RGMII1_RXC PADCFG: WKUP_PADCONFIG_33 0x4301C084	MCU_RGMII1_RXC	0	I	1.8 V/3.3 V	Off / Off / Off	Off / Off / Off	7	PU/PD	VDDSHV2_MCU	Yes	LVC MOS	No
			MCU_RMII1_REF_CLK	1	I									
			WKUP_GPIO0_47	7	IO									
C37	C12	MCU_RGMII1_RX_CTL PADCFG: WKUP_PADCONFIG_27 0x4301C06C	MCU_RGMII1_RX_CTL	0	I	1.8 V/3.3 V	Off / Off / Off	Off / Off / Off	7	PU/PD	VDDSHV2_MCU	Yes	LVC MOS	No
			MCU_RMII1_RX_ER	1	I									
			WKUP_GPIO0_41	7	IO									
E36	A14	MCU_RGMII1_TXC PADCFG: WKUP_PADCONFIG_32 0x4301C080	MCU_RGMII1_TXC	0	O	1.8 V/3.3 V	Off / Off / Off	Off / Off / Off	7	PU/PD	VDDSHV2_MCU	Yes	LVC MOS	No
			MCU_RMII1_TX_EN	1	O									
			WKUP_GPIO0_46	7	IO									
C38	B14	MCU_RGMII1_TX_CTL PADCFG: WKUP_PADCONFIG_26 0x4301C068	MCU_RGMII1_TX_CTL	0	O	1.8 V/3.3 V	Off / Off / Off	Off / Off / Off	7	PU/PD	VDDSHV2_MCU	Yes	LVC MOS	No
			MCU_RMII1_CRD_DV	1	I									
			WKUP_GPIO0_40	7	IO									
A35	E13	MCU_RGMII1_RD0 PADCFG: WKUP_PADCONFIG_37 0x4301C094	MCU_RGMII1_RD0	0	I	1.8 V/3.3 V	Off / Off / Off	Off / Off / Off	7	PU/PD	VDDSHV2_MCU	Yes	LVC MOS	No
			MCU_RMII1_RXD0	1	I									
			WKUP_GPIO0_51	7	IO									
B36	D14	MCU_RGMII1_RD1 PADCFG: WKUP_PADCONFIG_36 0x4301C090	MCU_RGMII1_RD1	0	I	1.8 V/3.3 V	Off / Off / Off	Off / Off / Off	7	PU/PD	VDDSHV2_MCU	Yes	LVC MOS	No
			MCU_RMII1_RXD1	1	I									
			WKUP_GPIO0_50	7	IO									
C36	D12	MCU_RGMII1_RD2 PADCFG: WKUP_PADCONFIG_35 0x4301C08C	MCU_RGMII1_RD2	0	I	1.8 V/3.3 V	Off / Off / Off	Off / Off / Off	7	PU/PD	VDDSHV2_MCU	Yes	LVC MOS	No
			MCU_TIMER_IO5	1	IO									
			WKUP_GPIO0_62	7	IO									
D36	D13	MCU_RGMII1_RD3 PADCFG: WKUP_PADCONFIG_34 0x4301C088	MCU_RGMII1_RD3	0	I	1.8 V/3.3 V	Off / Off / Off	Off / Off / Off	7	PU/PD	VDDSHV2_MCU	Yes	LVC MOS	No
			MCU_TIMER_IO4	1	IO									
			WKUP_GPIO0_48	7	IO									
D37	B13	MCU_RGMII1_TD0 PADCFG: WKUP_PADCONFIG_31 0x4301C07C	MCU_RGMII1_TD0	0	O	1.8 V/3.3 V	Off / Off / Off	Off / Off / Off	7	PU/PD	VDDSHV2_MCU	Yes	LVC MOS	No
			MCU_RMII1_TXD0	1	O									
			WKUP_GPIO0_45	7	IO									
D38	A13	MCU_RGMII1_TD1 PADCFG: WKUP_PADCONFIG_30 0x4301C078	MCU_RGMII1_TD1	0	O	1.8 V/3.3 V	Off / Off / Off	Off / Off / Off	7	PU/PD	VDDSHV2_MCU	Yes	LVC MOS	No
			MCU_RMII1_TXD1	1	O									
			WKUP_GPIO0_44	7	IO									

Table 5-1. Pin Attributes (ALY, AND Packages) (continued)

ALY Ball Num [1]	AND Ball Num [1]	Ball Name [2] PADCFG Register [15] PADCFG Address [16]	Signal Name [3]	Mux Mode [4]	Signal Type [5]	I/O Voltage [6]	Ball State DURING Reset (RX/TX/PULL) [7]	Ball State AFTER Reset (RX/TX/PULL) [8]	Mux Mode AFTER Reset [9]	Pull Type [10]	Power [11]	Hys [12]	Voltage Buffer Type [13]	IO RET [14]
E37	B12	MCU_RGMII1_TD2 PADCFG: WKUP_PADCONFIG_29 0x4301C074	MCU_RGMII1_TD2	0	O	1.8 V/3.3 V	Off / Off / Off	Off / Off / Off	7	PU/PD	VDDSHV2_MCU	Yes	LVCMOS	No
			MCU_TIMER_IO3	1	IO									
			MCU_ADC_EXT_TRIGGER1	3	I									
			WKUP_GPIO0_43	7	IO									
E38	A12	MCU_RGMII1_TD3 PADCFG: WKUP_PADCONFIG_28 0x4301C070	MCU_RGMII1_TD3	0	O	1.8 V/3.3 V	Off / Off / Off	Off / Off / Off	7	PU/PD	VDDSHV2_MCU	Yes	LVCMOS	No
			MCU_TIMER_IO2	1	IO									
			MCU_ADC_EXT_TRIGGER0	3	I									
			WKUP_GPIO0_42	7	IO									
N36	C22	MCU_SAFETY_ERRORn PADCFG: WKUP_PADCONFIG_69 0x4301C114	MCU_SAFETY_ERRORn	0	IO	1.8 V	Off / Off / Down	On / SS / Down	0	PU/PD	VDDA_WKUP	Yes	LVCMOS	No
G38	F15	MCU_SPI0_CLK PADCFG: WKUP_PADCONFIG_40 0x4301C0A0	MCU_SPI0_CLK	0	IO	1.8 V/3.3 V	On / Off / Off	On / Off / Off	7	PU/PD	VDDSHV0_MCU	Yes	LVCMOS	Yes
			WKUP_GPIO0_54	7	IO									
			MCU_BOOTMODE00	BOOTS TRAP	I									
F37	E19	MCU_SPI0_CS0 PADCFG: WKUP_PADCONFIG_43 0x4301C0AC	MCU_SPI0_CS0	0	IO	1.8 V/3.3 V	Off / Off / Off	Off / Off / Off	7	PU/PD	VDDSHV0_MCU	Yes	LVCMOS	Yes
			MCU_TIMER_IO1	4	IO									
			WKUP_GPIO0_70	7	IO									
H36	E18	MCU_SPI0_D0 PADCFG: WKUP_PADCONFIG_41 0x4301C0A4	MCU_SPI0_D0	0	IO	1.8 V/3.3 V	On / Off / Off	On / Off / Off	7	PU/PD	VDDSHV0_MCU	Yes	LVCMOS	Yes
			WKUP_GPIO0_55	7	IO									
			MCU_BOOTMODE01	BOOTS TRAP	I									
J38	E14	MCU_SPI0_D1 PADCFG: WKUP_PADCONFIG_42 0x4301C0A8	MCU_SPI0_D1	0	IO	1.8 V/3.3 V	On / Off / Off	On / Off / Off	7	PU/PD	VDDSHV0_MCU	Yes	LVCMOS	Yes
			MCU_TIMER_IO0	4	IO									
			WKUP_GPIO0_69	7	IO									
			MCU_BOOTMODE02	BOOTS TRAP	I									
AJ7	AH2	MMC0_CALPAD	MMC0_CALPAD		A	1.8 V				PU/PD	VDD5_MMC0		eMMCPHY	No
AK5	AJ2	MMC0_CLK	MMC0_CLK		O	1.8 V	On / Low / Off	On / SS / Off		PU/PD	VDD5_MMC0		eMMCPHY	No
AL8	AL2	MMC0_CMD	MMC0_CMD		IO	1.8 V	On / Off / Up	On / SS / Up		PU/PD	VDD5_MMC0		eMMCPHY	No
AK4	AJ1	MMC0_DS	MMC0_DS		IO	1.8 V	On / Off / Down	On / Off / Down		PU/PD	VDD5_MMC0		eMMCPHY	No

Table 5-1. Pin Attributes (ALY, AND Packages) (continued)

ALY Ball Num [1]	AND Ball Num [1]	Ball Name [2] PADCFG Register [15] PADCFG Address [16]	Signal Name [3]	Mux Mode [4]	Signal Type [5]	I/O Voltage [6]	Ball State DURING Reset (RX/TX/PULL) [7]	Ball State AFTER Reset (RX/TX/PULL) [8]	Mux Mode AFTER Reset [9]	Pull Type [10]	Power [11]	Hys [12]	Voltage Buffer Type [13]	IO RET [14]
AB38	D33	MMC1_CLK PADCFG: PADCONFIG_65 0x0011C104	MMC1_CLK	0	IO	1.8 V/3.3 V	Off / Off / Off	Off / Off / Off	7	PU/PD	VDDSHV5	Yes	SDIO	No
			UART8_RXD	1	I									
			TIMER_IO6	3	IO									
			EHRPWM2_B	4	IO									
			UART4_CTSn	5	I									
			EHRPWM5_A	6	IO									
			GPIO0_64	7	IO									
			SPI1_CLK	8	IO									
			UART0_RTSn	9	O									
			I2C6_SDA	10	IOD									
			MCAN15_TX	11	O									
			PCIE2_CLKREQn	12	IO									
AB36	E32	MMC1_CMD PADCFG: PADCONFIG_66 0x0011C108	MMC1_CMD	0	IO	1.8 V/3.3 V	Off / Off / Off	Off / Off / Off	7	PU/PD	VDDSHV5	Yes	SDIO	No
			UART8_TXD	1	O									
			TIMER_IO7	3	IO									
			EHRPWM2_A	4	IO									
			UART4_RTSn	5	O									
			GPIO0_65	7	IO									
			SPI1_D1	8	IO									
			I2C6_SCL	10	IOD									
			MCAN15_RX	11	I									
PCIE3_CLKREQn	12	IO												
AK9	AM1	MMC0_DAT0	MMC0_DAT0		IO	1.8 V	On / Off / Up	On / SS / Up		PU/PD	VDD5_MMC0		eMMC PHY	No
AL6	AK3	MMC0_DAT1	MMC0_DAT1		IO	1.8 V	On / Off / Up	On / SS / Up		PU/PD	VDD5_MMC0		eMMC PHY	No
AK8	AL1	MMC0_DAT2	MMC0_DAT2		IO	1.8 V	On / Off / Up	On / SS / Up		PU/PD	VDD5_MMC0		eMMC PHY	No
AK6	AK1	MMC0_DAT3	MMC0_DAT3		IO	1.8 V	On / Off / Up	On / SS / Up		PU/PD	VDD5_MMC0		eMMC PHY	No
AK7	AJ3	MMC0_DAT4	MMC0_DAT4		IO	1.8 V	On / Off / Up	On / SS / Up		PU/PD	VDD5_MMC0		eMMC PHY	No
AL7	AH3	MMC0_DAT5	MMC0_DAT5		IO	1.8 V	On / Off / Up	On / SS / Up		PU/PD	VDD5_MMC0		eMMC PHY	No
AL5	AJ4	MMC0_DAT6	MMC0_DAT6		IO	1.8 V	On / Off / Up	On / SS / Up		PU/PD	VDD5_MMC0		eMMC PHY	No
AK3	AK2	MMC0_DAT7	MMC0_DAT7		IO	1.8 V	On / Off / Up	On / SS / Up		PU/PD	VDD5_MMC0		eMMC PHY	No

Table 5-1. Pin Attributes (ALY, AND Packages) (continued)

ALY Ball Num [1]	AND Ball Num [1]	Ball Name [2] PADCFG Register [15] PADCFG Address [16]	Signal Name [3]	Mux Mode [4]	Signal Type [5]	I/O Voltage [6]	Ball State DURING Reset (RX/TX/PULL) [7]	Ball State AFTER Reset (RX/TX/PULL) [8]	Mux Mode AFTER Reset [9]	Pull Type [10]	Power [11]	Hys [12]	Voltage Buffer Type [13]	IO RET [14]
AA33	F28	MMC1_DAT0 PADCFG: PADCONFIG_63 0x0011C0FC	MMC1_DAT0	0	IO	1.8 V/3.3 V	Off / Off / Off	Off / Off / Off	7	PU/PD	VDDSHV5	Yes	SDIO	No
			UART7_RTSn	1	O									
			ECAP1_IN_APWM_OUT	2	IO									
			TIMER_IO5	3	IO									
			EHRPWM1_A	4	IO									
			UART4_TXD	5	O									
			GPIO0_63	7	IO									
			SPI1_D0	8	IO									
			UART5_RTSn	9	O									
			I2C4_SCL	10	IOD									
			UART2_TXD	11	O									
AB34	F29	MMC1_DAT1 PADCFG: PADCONFIG_62 0x0011C0F8	MMC1_DAT1	0	IO	1.8 V/3.3 V	Off / Off / Off	Off / Off / Off	7	PU/PD	VDDSHV5	Yes	SDIO	No
			UART7_CTSn	1	I									
			ECAP0_IN_APWM_OUT	2	IO									
			TIMER_IO4	3	IO									
			EHRPWM1_B	4	IO									
			UART4_RXD	5	I									
			EHRPWM4_A	6	IO									
			GPIO0_62	7	IO									
			SPI1_CS2	8	IO									
			UART5_CTSn	9	I									
			I2C4_SDA	10	IOD									
UART2_RXD	11	I												
AA32	E30	MMC1_DAT2 PADCFG: PADCONFIG_61 0x0011C0F4	MMC1_DAT2	0	IO	1.8 V/3.3 V	Off / Off / Off	Off / Off / Off	7	PU/PD	VDDSHV5	Yes	SDIO	No
			UART7_TXD	1	O									
			TIMER_IO3	3	IO									
			EHRPWM0_A	4	IO									
			GPIO0_61	7	IO									
			SPI1_CS1	8	IO									
			CPTS0_TS_SYNC	9	O									
			I2C3_SDA	10	IOD									
UART5_TXD	11	O												

Table 5-1. Pin Attributes (ALY, AND Packages) (continued)

ALY Ball Num [1]	AND Ball Num [1]	Ball Name [2] PADCFG Register [15] PADCFG Address [16]	Signal Name [3]	Mux Mode [4]	Signal Type [5]	I/O Voltage [6]	Ball State DURING Reset (RX/TX/PULL) [7]	Ball State AFTER Reset (RX/TX/PULL) [8]	Mux Mode AFTER Reset [9]	Pull Type [10]	Power [11]	Hys [12]	Voltage Buffer Type [13]	IO RET [14]
AC38	F30	MMC1_DAT3 PADCFG: PADCONFIG_60 0x0011C0F0	MMC1_DAT3	0	IO	1.8 V/3.3 V	Off / Off / Off	Off / Off / Off	7	PU/PD	VDDSHV5	Yes	SDIO	No
			UART7_RXD	1	I									
			PCIE1_CLKREQn	2	IO									
			TIMER_IO2	3	IO									
			EHRPWM0_B	4	IO									
			EHRPWM3_A	6	IO									
			GPIO0_60	7	IO									
			SPI1_CS0	8	IO									
			UART0_CTSn	9	I									
			I2C3_SCL	10	IOD									
			UART5_RXD	11	I									
P38	B23	OSC1_XI	OSC1_XI		I	1.8 V					VDDA_OSC1	Yes	HFXOSC	
N37	A22	OSC1_XO	OSC1_XO		O	1.8 V					VDDA_OSC1	Yes	HFXOSC	
AP4	AJ13	PCIE_REFCLK0_N_OUT	PCIE_REFCLK0_N_OUT		O	1.8 V					VDDA_0P8_SERDES0_1 / VDDA_0P8_SERDES_C0_1 / VDDA_1P8_SERDES0_1		4L_PHY	
AP5	AJ12	PCIE_REFCLK0_P_OUT	PCIE_REFCLK0_P_OUT		O	1.8 V					VDDA_0P8_SERDES0_1 / VDDA_0P8_SERDES_C0_1 / VDDA_1P8_SERDES0_1		4L_PHY	
AN8	AH14	PCIE_REFCLK1_N_OUT	PCIE_REFCLK1_N_OUT		O	1.8 V					VDDA_0P8_SERDES0_1 / VDDA_0P8_SERDES_C0_1 / VDDA_1P8_SERDES0_1		4L_PHY	
AN9	AH13	PCIE_REFCLK1_P_OUT	PCIE_REFCLK1_P_OUT		O	1.8 V					VDDA_0P8_SERDES0_1 / VDDA_0P8_SERDES_C0_1 / VDDA_1P8_SERDES0_1		4L_PHY	

Table 5-1. Pin Attributes (ALY, AND Packages) (continued)

ALY Ball Num [1]	AND Ball Num [1]	Ball Name [2] PADCFG Register [15] PADCFG Address [16]	Signal Name [3]	Mux Mode [4]	Signal Type [5]	I/O Voltage [6]	Ball State DURING Reset (RX/TX/PULL) [7]	Ball State AFTER Reset (RX/TX/PULL) [8]	Mux Mode AFTER Reset [9]	Pull Type [10]	Power [11]	Hys [12]	Voltage Buffer Type [13]	IO RET [14]
AN5	AH11	PCIE_REFCLK2_N_OUT	PCIE_REFCLK2_N_OUT		O	1.8 V					VDDA_0P8_SERDES0_1 / VDDA_0P8_SERDES_C0_1 / VDDA_1P8_SERDES0_1		4L_PHY	
AN6	AH10	PCIE_REFCLK2_P_OUT	PCIE_REFCLK2_P_OUT		O	1.8 V					VDDA_0P8_SERDES0_1 / VDDA_0P8_SERDES_C0_1 / VDDA_1P8_SERDES0_1		4L_PHY	
AP7	AJ16	PCIE_REFCLK3_N_OUT	PCIE_REFCLK3_N_OUT		O	1.8 V					VDDA_0P8_SERDES0_1 / VDDA_0P8_SERDES_C0_1 / VDDA_1P8_SERDES0_1		4L_PHY	
AP8	AJ15	PCIE_REFCLK3_P_OUT	PCIE_REFCLK3_P_OUT		O	1.8 V					VDDA_0P8_SERDES0_1 / VDDA_0P8_SERDES_C0_1 / VDDA_1P8_SERDES0_1		4L_PHY	
L38	B16	PMIC_POWER_EN1	PMIC_POWER_EN1	0	O	1.8 V/3.3 V	Off / Off / Off	Off / Off / Off	7	PU/PD	VDDSHV0_MCU	Yes	LVCMOS	Yes
		PADCFG: WKUP_PADCONFIG_68 0x4301C110	MCU_I3C0_SDAPULLEN	5	OD									
			WKUP_GPIO0_88	7	IO									
AJ34	T30	PMIC_WAKE0n PADCFG: PADCONFIG_13 0x0011C034	PMIC_WAKE0n	0	O	1.8 V/3.3 V	Off / Off / Off	Off / Off / Off	7	PU/PD	VDDSHV2	Yes	LVCMOS	No
			MCASP4_AXR0	1	IO									
			DSS_FSYNC1	4	O									
			MCAN17_RX	5	I									
			GPMC0_WEn	6	O									
			GPIO0_13	7	IO									
			SPI6_CS0	8	IO									
			TRC_DATA0	10	O									
			UART9_RTSn	11	O									
UART7_TXD	13	O												
AUDIO_EXT_REFCLK0	14	IO												

Table 5-1. Pin Attributes (ALY, AND Packages) (continued)

ALY Ball Num [1]	AND Ball Num [1]	Ball Name [2] PADCFG Register [15] PADCFG Address [16]	Signal Name [3]	Mux Mode [4]	Signal Type [5]	I/O Voltage [6]	Ball State DURING Reset (RX/TX/PULL) [7]	Ball State AFTER Reset (RX/TX/PULL) [8]	Mux Mode AFTER Reset [9]	Pull Type [10]	Power [11]	Hys [12]	Voltage Buffer Type [13]	IO RET [14]
P33	D24	PORz PADCFG: WKUP_PADCONFIG_94 0x4301C178	PORz	0	I	1.8 V			0		VDDA_WKU_P	Yes	FS_RESET	No
AL38	W32	RESETSTATz PADCFG: PADCONFIG_67 0x0011C10C	RESETSTATz	0	O	1.8 V/3.3 V	Off / Low / Off	Off / SS / Off	0	PU/PD	VDDSHV0	Yes	LVC MOS	No
F34	G20	RESET_REQz PADCFG: WKUP_PADCONFIG_93 0x4301C174	RESET_REQz	0	I	1.8 V/3.3 V	On / Off / Up	On / Off / Up	0	PU/PD	VDDSHV0_MCU	Yes	LVC MOS	No
AU9	AK15	SERDES0_REFCLK_N	SERDES0_REFCLK_N		IO	1.8 V					VDDA_0P8_SERDES0_1 / VDDA_0P8_SERDES_C0_1 / VDDA_1P8_SERDES0_1		4L_PHY	
AU8	AK14	SERDES0_REFCLK_P	SERDES0_REFCLK_P		IO	1.8 V					VDDA_0P8_SERDES0_1 / VDDA_0P8_SERDES_C0_1 / VDDA_1P8_SERDES0_1		4L_PHY	
AN11	AG7	SERDES0_REXT	SERDES0_REXT		I	1.8 V					VDDA_0P8_SERDES0_1 / VDDA_0P8_SERDES_C0_1 / VDDA_1P8_SERDES0_1		4L_PHY	
AV3	AN5	SERDES1_REFCLK_N	SERDES1_REFCLK_N	0	IO	1.8 V					VDDA_0P8_SERDES0_1 / VDDA_0P8_SERDES_C0_1 / VDDA_1P8_SERDES0_1		4L_PHY	
AV4	AN6	SERDES1_REFCLK_P	SERDES1_REFCLK_P	0	IO	1.8 V					VDDA_0P8_SERDES0_1 / VDDA_0P8_SERDES_C0_1 / VDDA_1P8_SERDES0_1		4L_PHY	

Table 5-1. Pin Attributes (ALY, AND Packages) (continued)

ALY Ball Num [1]	AND Ball Num [1]	Ball Name [2] PADCFG Register [15] PADCFG Address [16]	Signal Name [3]	Mux Mode [4]	Signal Type [5]	I/O Voltage [6]	Ball State DURING Reset (RX/TX/PULL) [7]	Ball State AFTER Reset (RX/TX/PULL) [8]	Mux Mode AFTER Reset [9]	Pull Type [10]	Power [11]	Hys [12]	Voltage Buffer Type [13]	IO RET [14]
AL9	AH9	SERDES1_REXT	SERDES1_REXT	0	I	1.8 V					VDDA_0P8_SERDES0_1 / VDDA_0P8_SERDES_C0_1 / VDDA_1P8_SERDES0_1		4L_PHY	
AV21		SERDES2_REFCLK_N	SERDES2_REFCLK_N		IO	1.8 V					VDDA_0P8_SERDES2 / VDDA_0P8_SERDES_C2 / VDDA_1P8_SERDES2		4L_PHY	
AV22		SERDES2_REFCLK_P	SERDES2_REFCLK_P		IO	1.8 V					VDDA_0P8_SERDES2 / VDDA_0P8_SERDES_C2 / VDDA_1P8_SERDES2		4L_PHY	
AL20		SERDES2_REXT	SERDES2_REXT	0	IO	1.8 V					VDDA_0P8_SERDES2 / VDDA_0P8_SERDES_C2 / VDDA_1P8_SERDES2		4L_PHY	
AV16	AK21	SERDES4_REFCLK_N	SERDES4_REFCLK_N		IO	1.8 V					VDDA_0P8_SERDES4 / VDDA_0P8_SERDES_C4 / VDDA_1P8_SERDES4		4L_PHY	
AV15	AK20	SERDES4_REFCLK_P	SERDES4_REFCLK_P		IO	1.8 V					VDDA_0P8_SERDES4 / VDDA_0P8_SERDES_C4 / VDDA_1P8_SERDES4		4L_PHY	
AM19	AH23	SERDES4_REXT	SERDES4_REXT		IO	1.8 V					VDDA_0P8_SERDES4 / VDDA_0P8_SERDES_C4 / VDDA_1P8_SERDES4		4L_PHY	

Table 5-1. Pin Attributes (ALY, AND Packages) (continued)

ALY Ball Num [1]	AND Ball Num [1]	Ball Name [2] PADCFG Register [15] PADCFG Address [16]	Signal Name [3]	Mux Mode [4]	Signal Type [5]	I/O Voltage [6]	Ball State DURING Reset (RX/TX/PULL) [7]	Ball State AFTER Reset (RX/TX/PULL) [8]	Mux Mode AFTER Reset [9]	Pull Type [10]	Power [11]	Hys [12]	Voltage Buffer Type [13]	IO RET [14]
AR8	AM12	SERDES0_RX0_N	PCIE1_RXN0		I	1.8 V					VDDA_0P8_SERDES0_1 / VDDA_0P8_SERDES_C0_1 / VDDA_1P8_SERDES0_1		4L_PHY	
AR9	AM13	SERDES0_RX0_P	PCIE1_RXP0	1	I	1.8 V					VDDA_0P8_SERDES0_1 / VDDA_0P8_SERDES_C0_1 / VDDA_1P8_SERDES0_1		4L_PHY	
AT10	AL13	SERDES0_RX1_N	PCIE1_RXN1	1	I	1.8 V					VDDA_0P8_SERDES0_1 / VDDA_0P8_SERDES_C0_1 / VDDA_1P8_SERDES0_1		4L_PHY	
AT11	AL14	SERDES0_RX1_P	PCIE1_RXP1		I	1.8 V					VDDA_0P8_SERDES0_1 / VDDA_0P8_SERDES_C0_1 / VDDA_1P8_SERDES0_1		4L_PHY	
AR11	AN15	SERDES0_RX2_N	USB0_SSRX1N		I	1.8 V					VDDA_0P8_SERDES0_1 / VDDA_0P8_SERDES_C0_1 / VDDA_1P8_SERDES0_1		4L_PHY	
			PCIE3_RXN0		I									
			PCIE1_RXN2		I									
AR12	AN14	SERDES0_RX2_P	PCIE1_RXP2		I	1.8 V					VDDA_0P8_SERDES0_1 / VDDA_0P8_SERDES_C0_1 / VDDA_1P8_SERDES0_1		4L_PHY	
			USB0_SSRX1P		I									
			PCIE3_RXP0		I									

Table 5-1. Pin Attributes (ALY, AND Packages) (continued)

ALY Ball Num [1]	AND Ball Num [1]	Ball Name [2] PADCFG Register [15] PADCFG Address [16]	Signal Name [3]	Mux Mode [4]	Signal Type [5]	I/O Voltage [6]	Ball State DURING Reset (RX/TX/PULL) [7]	Ball State AFTER Reset (RX/TX/PULL) [8]	Mux Mode AFTER Reset [9]	Pull Type [10]	Power [11]	Hys [12]	Voltage Buffer Type [13]	IO RET [14]
AU11	AL17	SERDES0_RX3_N	USB0_SSRX2N		I	1.8 V					VDDA_0P8_SERDES0_1 / VDDA_0P8_SERDES_C0_1 / VDDA_1P8_SERDES0_1		4L_PHY	
			PCIE3_RXN1		I									
			PCIE1_RXN3		I									
AU12	AL16	SERDES0_RX3_P	PCIE3_RXP1		I	1.8 V					VDDA_0P8_SERDES0_1 / VDDA_0P8_SERDES_C0_1 / VDDA_1P8_SERDES0_1		4L_PHY	
			PCIE1_RXP3		I									
			USB0_SSRX2P		I									
AT7	AN11	SERDES0_TX0_N	PCIE1_TXN0	1	O	1.8 V					VDDA_0P8_SERDES0_1 / VDDA_0P8_SERDES_C0_1 / VDDA_1P8_SERDES0_1		4L_PHY	
AT8	AN12	SERDES0_TX0_P	PCIE1_TXP0	1	O	1.8 V					VDDA_0P8_SERDES0_1 / VDDA_0P8_SERDES_C0_1 / VDDA_1P8_SERDES0_1		4L_PHY	
AP10	AJ19	SERDES0_TX1_N	PCIE1_TXN1	1	O	1.8 V					VDDA_0P8_SERDES0_1 / VDDA_0P8_SERDES_C0_1 / VDDA_1P8_SERDES0_1		4L_PHY	
AP11	AJ18	SERDES0_TX1_P	PCIE1_TXP1	1	O	1.8 V					VDDA_0P8_SERDES0_1 / VDDA_0P8_SERDES_C0_1 / VDDA_1P8_SERDES0_1		4L_PHY	

Table 5-1. Pin Attributes (ALY, AND Packages) (continued)

ALY Ball Num [1]	AND Ball Num [1]	Ball Name [2] PADCFG Register [15] PADCFG Address [16]	Signal Name [3]	Mux Mode [4]	Signal Type [5]	I/O Voltage [6]	Ball State DURING Reset (RX/TX/PULL) [7]	Ball State AFTER Reset (RX/TX/PULL) [8]	Mux Mode AFTER Reset [9]	Pull Type [10]	Power [11]	Hys [12]	Voltage Buffer Type [13]	IO RET [14]
AV9	AM16	SERDES0_TX2_N	PCIE1_TXN2	1	O	1.8 V					VDDA_0P8_SERDES0_1 / VDDA_0P8_SERDES_C0_1 / VDDA_1P8_SERDES0_1		4L_PHY	
			USB0_SSTX1N	2	O									
			PCIE3_TXN0	3	O									
AV10	AM15	SERDES0_TX2_P	PCIE1_TXP2	1	O	1.8 V					VDDA_0P8_SERDES0_1 / VDDA_0P8_SERDES_C0_1 / VDDA_1P8_SERDES0_1		4L_PHY	
			USB0_SSTX1P	2	O									
			PCIE3_TXP0	3	O									
AV12	AK18	SERDES0_TX3_N	PCIE3_TXN1		O	1.8 V					VDDA_0P8_SERDES0_1 / VDDA_0P8_SERDES_C0_1 / VDDA_1P8_SERDES0_1		4L_PHY	
			USB0_SSTX2N		O									
			PCIE1_TXN3		O									
AV13	AK17	SERDES0_TX3_P	PCIE1_TXP3		O	1.8 V					VDDA_0P8_SERDES0_1 / VDDA_0P8_SERDES_C0_1 / VDDA_1P8_SERDES0_1		4L_PHY	
			USB0_SSTX2P		O									
			PCIE3_TXP1		O									
AU5	AL10	SERDES1_RX0_N	SGMII3_RXN0		I	1.8 V					VDDA_0P8_SERDES0_1 / VDDA_0P8_SERDES_C0_1 / VDDA_1P8_SERDES0_1		4L_PHY	
			PCIE0_RXN0		I									
AU6	AL11	SERDES1_RX0_P	SGMII3_RXP0		I	1.8 V					VDDA_0P8_SERDES0_1 / VDDA_0P8_SERDES_C0_1 / VDDA_1P8_SERDES0_1		4L_PHY	
			PCIE0_RXP0		I									

Table 5-1. Pin Attributes (ALY, AND Packages) (continued)

ALY Ball Num [1]	AND Ball Num [1]	Ball Name [2] PADCFG Register [15] PADCFG Address [16]	Signal Name [3]	Mux Mode [4]	Signal Type [5]	I/O Voltage [6]	Ball State DURING Reset (RX/TX/PULL) [7]	Ball State AFTER Reset (RX/TX/PULL) [8]	Mux Mode AFTER Reset [9]	Pull Type [10]	Power [11]	Hys [12]	Voltage Buffer Type [13]	IO RET [14]
AT4	AN8	SERDES1_RX1_N	PCIE0_RXN1		I	1.8 V					VDDA_0P8_SERDES0_1 / VDDA_0P8_SERDES_C0_1 / VDDA_1P8_SERDES0_1		4L_PHY	
			SGMII4_RXN0		I									
AT5	AN9	SERDES1_RX1_P	SGMII4_RXP0		I	1.8 V					VDDA_0P8_SERDES0_1 / VDDA_0P8_SERDES_C0_1 / VDDA_1P8_SERDES0_1		4L_PHY	
			PCIE0_RXP1		I									
AU2	AM6	SERDES1_RX2_N	PCIE2_RXN0		I	1.8 V					VDDA_0P8_SERDES0_1 / VDDA_0P8_SERDES_C0_1 / VDDA_1P8_SERDES0_1		4L_PHY	
			PCIE0_RXN2		I									
			SGMII1_RXN0		I									
AU3	AM7	SERDES1_RX2_P	PCIE0_RXP2		I	1.8 V					VDDA_0P8_SERDES0_1 / VDDA_0P8_SERDES_C0_1 / VDDA_1P8_SERDES0_1		4L_PHY	
			SGMII1_RXP0		I									
			PCIE2_RXP0		I									
AT1	AL7	SERDES1_RX3_N	SGMII2_RXN0		I	1.8 V					VDDA_0P8_SERDES0_1 / VDDA_0P8_SERDES_C0_1 / VDDA_1P8_SERDES0_1		4L_PHY	
			PCIE0_RXN3		I									
			PCIE2_RXN1		I									
AT2	AL8	SERDES1_RX3_P	SGMII2_RXP0		I	1.8 V					VDDA_0P8_SERDES0_1 / VDDA_0P8_SERDES_C0_1 / VDDA_1P8_SERDES0_1		4L_PHY	
			PCIE2_RXP1		I									
			PCIE0_RXP3		I									

Table 5-1. Pin Attributes (ALY, AND Packages) (continued)

ALY Ball Num [1]	AND Ball Num [1]	Ball Name [2] PADCFG Register [15] PADCFG Address [16]	Signal Name [3]	Mux Mode [4]	Signal Type [5]	I/O Voltage [6]	Ball State DURING Reset (RX/TX/PULL) [7]	Ball State AFTER Reset (RX/TX/PULL) [8]	Mux Mode AFTER Reset [9]	Pull Type [10]	Power [11]	Hys [12]	Voltage Buffer Type [13]	IO RET [14]
AV6	AK11	SERDES1_TX0_N	PCIE0_TXN0		O	1.8 V					VDDA_0P8_SERDES0_1 / VDDA_0P8_SERDES_C0_1 / VDDA_1P8_SERDES0_1		4L_PHY	
			SGMII3_TXN0		O									
AV7	AK12	SERDES1_TX0_P	SGMII3_TXP0		O	1.8 V					VDDA_0P8_SERDES0_1 / VDDA_0P8_SERDES_C0_1 / VDDA_1P8_SERDES0_1		4L_PHY	
			PCIE0_TXP0		O									
AR5	AM9	SERDES1_TX1_N	PCIE0_TXN1		O	1.8 V					VDDA_0P8_SERDES0_1 / VDDA_0P8_SERDES_C0_1 / VDDA_1P8_SERDES0_1		4L_PHY	
			SGMII4_TXN0		O									
AR6	AM10	SERDES1_TX1_P	PCIE0_TXP1		O	1.8 V					VDDA_0P8_SERDES0_1 / VDDA_0P8_SERDES_C0_1 / VDDA_1P8_SERDES0_1		4L_PHY	
			SGMII4_TXP0		O									
AR2	AK8	SERDES1_TX2_N	SGMII1_TXN0		O	1.8 V					VDDA_0P8_SERDES0_1 / VDDA_0P8_SERDES_C0_1 / VDDA_1P8_SERDES0_1		4L_PHY	
			PCIE2_TXN0		O									
			PCIE0_TXN2		O									
AR3	AK9	SERDES1_TX2_P	SGMII1_TXP0		O	1.8 V					VDDA_0P8_SERDES0_1 / VDDA_0P8_SERDES_C0_1 / VDDA_1P8_SERDES0_1		4L_PHY	
			PCIE2_TXP0		O									
			PCIE0_TXP2		O									

Table 5-1. Pin Attributes (ALY, AND Packages) (continued)

ALY Ball Num [1]	AND Ball Num [1]	Ball Name [2] PADCFG Register [15] PADCFG Address [16]	Signal Name [3]	Mux Mode [4]	Signal Type [5]	I/O Voltage [6]	Ball State DURING Reset (RX/TX/PULL) [7]	Ball State AFTER Reset (RX/TX/PULL) [8]	Mux Mode AFTER Reset [9]	Pull Type [10]	Power [11]	Hys [12]	Voltage Buffer Type [13]	IO RET [14]
AP1	AJ9	SERDES1_TX3_N	PCIE0_TXN3		O	1.8 V					VDDA_0P8_SERDES0_1 / VDDA_0P8_SERDES_C0_1 / VDDA_1P8_SERDES0_1		4L_PHY	
			SGMII2_TXN0		O									
			PCIE2_TXN1		O									
AP2	AJ10	SERDES1_TX3_P	SGMII2_TXP0		O	1.8 V					VDDA_0P8_SERDES0_1 / VDDA_0P8_SERDES_C0_1 / VDDA_1P8_SERDES0_1		4L_PHY	
			PCIE2_TXP1		O									
			PCIE0_TXP3		O									
AU23		SERDES2_RX0_N	SGMII5_RXN0	0	I	1.8 V				VDDA_0P8_SERDES2 / VDDA_0P8_SERDES_C2 / VDDA_1P8_SERDES2		4L_PHY		
AU24		SERDES2_RX0_P	SGMII5_RXP0	0	I	1.8 V				VDDA_0P8_SERDES2 / VDDA_0P8_SERDES_C2 / VDDA_1P8_SERDES2		4L_PHY		
AT22		SERDES2_RX1_N	SGMII6_RXN0	0	I	1.8 V				VDDA_0P8_SERDES2 / VDDA_0P8_SERDES_C2 / VDDA_1P8_SERDES2		4L_PHY		
AT23		SERDES2_RX1_P	SGMII6_RXP0	0	I	1.8 V				VDDA_0P8_SERDES2 / VDDA_0P8_SERDES_C2 / VDDA_1P8_SERDES2		4L_PHY		
AU20		SERDES2_RX2_N	SGMII7_RXN0	0	I	1.8 V					VDDA_0P8_SERDES2 / VDDA_0P8_SERDES_C2 / VDDA_1P8_SERDES2		4L_PHY	
			SGMII1_RXN0	1	I									

Table 5-1. Pin Attributes (ALY, AND Packages) (continued)

ALY Ball Num [1]	AND Ball Num [1]	Ball Name [2] PADCFG Register [15] PADCFG Address [16]	Signal Name [3]	Mux Mode [4]	Signal Type [5]	I/O Voltage [6]	Ball State DURING Reset (RX/TX/PULL) [7]	Ball State AFTER Reset (RX/TX/PULL) [8]	Mux Mode AFTER Reset [9]	Pull Type [10]	Power [11]	Hys [12]	Voltage Buffer Type [13]	IO RET [14]
AU21		SERDES2_RX2_P	SGMII7_RXP0	0	I	1.8 V					VDDA_0P8_SERDES2 / VDDA_0P8_SERDES_C2 / VDDA_1P8_SERDES2		4L_PHY	
			SGMII1_RXP0	1	I									
AT19		SERDES2_RX3_N	SGMII8_RXN0	0	I	1.8 V					VDDA_0P8_SERDES2 / VDDA_0P8_SERDES_C2 / VDDA_1P8_SERDES2		4L_PHY	
			SGMII2_RXN0	1	I									
AT20		SERDES2_RX3_P	SGMII8_RXP0	0	I	1.8 V					VDDA_0P8_SERDES2 / VDDA_0P8_SERDES_C2 / VDDA_1P8_SERDES2		4L_PHY	
			SGMII2_RXP0	1	I									
AV24		SERDES2_TX0_N	SGMII5_TXN0	0	O	1.8 V					VDDA_0P8_SERDES2 / VDDA_0P8_SERDES_C2 / VDDA_1P8_SERDES2		4L_PHY	
AV25		SERDES2_TX0_P	SGMII5_TXP0	0	O	1.8 V					VDDA_0P8_SERDES2 / VDDA_0P8_SERDES_C2 / VDDA_1P8_SERDES2		4L_PHY	
AR23		SERDES2_TX1_N	SGMII6_TXN0	0	O	1.8 V					VDDA_0P8_SERDES2 / VDDA_0P8_SERDES_C2 / VDDA_1P8_SERDES2		4L_PHY	
AR24		SERDES2_TX1_P	SGMII6_TXP0	0	O	1.8 V					VDDA_0P8_SERDES2 / VDDA_0P8_SERDES_C2 / VDDA_1P8_SERDES2		4L_PHY	

Table 5-1. Pin Attributes (ALY, AND Packages) (continued)

ALY Ball Num [1]	AND Ball Num [1]	Ball Name [2] PADCFG Register [15] PADCFG Address [16]	Signal Name [3]	Mux Mode [4]	Signal Type [5]	I/O Voltage [6]	Ball State DURING Reset (RX/TX/PULL) [7]	Ball State AFTER Reset (RX/TX/PULL) [8]	Mux Mode AFTER Reset [9]	Pull Type [10]	Power [11]	Hys [12]	Voltage Buffer Type [13]	IO RET [14]
AR20		SERDES2_TX2_N	SGMII7_TXN0	0	O	1.8 V					VDDA_0P8_SERDES2 / VDDA_0P8_SERDES_C2 / VDDA_1P8_SERDES2		4L_PHY	
			SGMII1_TXN0	1	O									
AR21		SERDES2_TX2_P	SGMII1_TXP0		O	1.8 V					VDDA_0P8_SERDES2 / VDDA_0P8_SERDES_C2 / VDDA_1P8_SERDES2		4L_PHY	
			SGMII7_TXP0		O									
AP19		SERDES2_TX3_N	SGMII8_TXN0		O	1.8 V					VDDA_0P8_SERDES2 / VDDA_0P8_SERDES_C2 / VDDA_1P8_SERDES2		4L_PHY	
			SGMII2_TXN0		O									
AP20		SERDES2_TX3_P	SGMII2_TXP0		O	1.8 V					VDDA_0P8_SERDES2 / VDDA_0P8_SERDES_C2 / VDDA_1P8_SERDES2		4L_PHY	
			SGMII8_TXP0		O									
AR14	AN17	SERDES4_RX0_N	SGMII5_RXN0		I	1.8 V					VDDA_0P8_SERDES4 / VDDA_0P8_SERDES_C4 / VDDA_1P8_SERDES4		4L_PHY	
AR15	AN18	SERDES4_RX0_P	SGMII5_RXP0		I	1.8 V					VDDA_0P8_SERDES4 / VDDA_0P8_SERDES_C4 / VDDA_1P8_SERDES4		4L_PHY	
AU14	AL19	SERDES4_RX1_N	SGMII6_RXN0		I	1.8 V					VDDA_0P8_SERDES4 / VDDA_0P8_SERDES_C4 / VDDA_1P8_SERDES4		4L_PHY	

Table 5-1. Pin Attributes (ALY, AND Packages) (continued)

ALY Ball Num [1]	AND Ball Num [1]	Ball Name [2] PADCFG Register [15] PADCFG Address [16]	Signal Name [3]	Mux Mode [4]	Signal Type [5]	I/O Voltage [6]	Ball State DURING Reset (RX/TX/PULL) [7]	Ball State AFTER Reset (RX/TX/PULL) [8]	Mux Mode AFTER Reset [9]	Pull Type [10]	Power [11]	Hys [12]	Voltage Buffer Type [13]	IO RET [14]
AU15	AL20	SERDES4_RX1_P	SGMII6_RXP0		I	1.8 V					VDDA_0P8_SERDES4 / VDDA_0P8_SERDES_C4 / VDDA_1P8_SERDES4		4L_PHY	
AR17	AK23	SERDES4_RX2_N	USB0_SSRX1N		I	1.8 V					VDDA_0P8_SERDES4 / VDDA_0P8_SERDES_C4 / VDDA_1P8_SERDES4		4L_PHY	
			SGMII7_RXN0		I									
AR18	AK24	SERDES4_RX2_P	USB0_SSRX1P		I	1.8 V					VDDA_0P8_SERDES4 / VDDA_0P8_SERDES_C4 / VDDA_1P8_SERDES4		4L_PHY	
			SGMII7_RXP0		I									
AU17	AM21	SERDES4_RX3_N	SGMII8_RXN0		I	1.8 V					VDDA_0P8_SERDES4 / VDDA_0P8_SERDES_C4 / VDDA_1P8_SERDES4		4L_PHY	
			USB0_SSRX2N		I									
AU18	AM22	SERDES4_RX3_P	USB0_SSRX2P		I	1.8 V					VDDA_0P8_SERDES4 / VDDA_0P8_SERDES_C4 / VDDA_1P8_SERDES4		4L_PHY	
			SGMII8_RXP0		I									
AP13	AJ21	SERDES4_TX0_N	SGMII5_TXN0		O	1.8 V					VDDA_0P8_SERDES4 / VDDA_0P8_SERDES_C4 / VDDA_1P8_SERDES4		4L_PHY	
			DP0_TXN0		O									
AP14	AJ22	SERDES4_TX0_P	SGMII5_TXP0		O	1.8 V					VDDA_0P8_SERDES4 / VDDA_0P8_SERDES_C4 / VDDA_1P8_SERDES4		4L_PHY	
			DP0_TXP0		O									

Table 5-1. Pin Attributes (ALY, AND Packages) (continued)

ALY Ball Num [1]	AND Ball Num [1]	Ball Name [2] PADCFG Register [15] PADCFG Address [16]	Signal Name [3]	Mux Mode [4]	Signal Type [5]	I/O Voltage [6]	Ball State DURING Reset (RX/TX/PULL) [7]	Ball State AFTER Reset (RX/TX/PULL) [8]	Mux Mode AFTER Reset [9]	Pull Type [10]	Power [11]	Hys [12]	Voltage Buffer Type [13]	IO RET [14]
AT13	AM18	SERDES4_TX1_N	SGMII6_TXN0		O	1.8 V					VDDA_0P8_SERDES4 / VDDA_0P8_SERDES_C4 / VDDA_1P8_SERDES4		4L_PHY	
			DP0_TXN1		O									
AT14	AM19	SERDES4_TX1_P	DP0_TXP1		O	1.8 V					VDDA_0P8_SERDES4 / VDDA_0P8_SERDES_C4 / VDDA_1P8_SERDES4		4L_PHY	
			SGMII6_TXP0		O									
AT16	AN20	SERDES4_TX2_N	DP0_TXN2		O	1.8 V					VDDA_0P8_SERDES4 / VDDA_0P8_SERDES_C4 / VDDA_1P8_SERDES4		4L_PHY	
			SGMII7_TXN0		O									
			USB0_SSTX1N		O									
AT17	AN21	SERDES4_TX2_P	SGMII7_TXP0		O	1.8 V					VDDA_0P8_SERDES4 / VDDA_0P8_SERDES_C4 / VDDA_1P8_SERDES4		4L_PHY	
			USB0_SSTX1P		O									
			DP0_TXP2		O									
AV18	AL22	SERDES4_TX3_N	SGMII8_TXN0		O	1.8 V					VDDA_0P8_SERDES4 / VDDA_0P8_SERDES_C4 / VDDA_1P8_SERDES4		4L_PHY	
			DP0_TXN3		O									
			USB0_SSTX2N		O									
AV19	AL23	SERDES4_TX3_P	DP0_TXP3		O	1.8 V					VDDA_0P8_SERDES4 / VDDA_0P8_SERDES_C4 / VDDA_1P8_SERDES4		4L_PHY	
			USB0_SSTX2P		O									
			SGMII8_TXP0		O									
AM34	Y31	SOC_SAFETY_ERRORn PADCFG: PADCONFIG_68 0x0011C110	SOC_SAFETY_ERRORn	0	IO	1.8 V/3.3 V	Off / Off / Down	On / SS / Down	0	PU/PD	VDDSHV0	Yes	LVC MOS	No

Table 5-1. Pin Attributes (ALY, AND Packages) (continued)

ALY Ball Num [1]	AND Ball Num [1]	Ball Name [2] PADCFG Register [15] PADCFG Address [16]	Signal Name [3]	Mux Mode [4]	Signal Type [5]	I/O Voltage [6]	Ball State DURING Reset (RX/TX/PULL) [7]	Ball State AFTER Reset (RX/TX/PULL) [8]	Mux Mode AFTER Reset [9]	Pull Type [10]	Power [11]	Hys [12]	Voltage Buffer Type [13]	IO RET [14]
AN38	V31	SPI0_CLK PADCFG: PADCONFIG_53 0x0011C0D4	SPI0_CLK	0	IO	1.8 V/3.3 V	Off / Off / Off	Off / Off / Off	7	PU/PD	VDDSHV0	Yes	LVCMOS	No
			UART1_CTSn	1	I									
			I2C2_SCL	2	IOD									
			MCASP3_AXR0	3	IO									
			EHRPWM2_A	5	IO									
			GPIO0_53	7	IO									
			UART8_TXD	11	O									
AM37	Y33	SPI0_CS0 PADCFG: PADCONFIG_51 0x0011C0CC	SPI0_CS0	0	IO	1.8 V/3.3 V	Off / Off / Off	Off / Off / Off	7	PU/PD	VDDSHV0	Yes	LVCMOS	No
			MCASP3_ACLKX	3	IO									
			MCASP3_ACLKR	4	IO									
			EHRPWM0_A	5	IO									
			GPIO0_51	7	IO									
			MCAN14_TX	9	O									
			DP0_HPD	12	I									
AP38	Y32	SPI0_CS1 PADCFG: PADCONFIG_52 0x0011C0D0	SPI0_CS1	0	IO	1.8 V/3.3 V	Off / Off / Off	Off / Off / Off	7	PU/PD	VDDSHV0	Yes	LVCMOS	No
			CPTS0_TS_COMP	1	O									
			UART0_RTSn	2	O									
			MCASP3_AFSX	3	IO									
			MCASP3_AFSR	4	IO									
			EHRPWM1_A	5	IO									
			GPIO0_52	7	IO									
			MCAN14_RX	9	I									
UART8_RXD	11	I												
AM35	V30	SPI0_D0 PADCFG: PADCONFIG_54 0x0011C0D8	SPI0_D0	0	IO	1.8 V/3.3 V	Off / Off / Off	Off / Off / Off	7	PU/PD	VDDSHV0	Yes	LVCMOS	No
			UART1_RTSn	1	O									
			I2C2_SDA	2	IOD									
			MCASP3_AXR1	3	IO									
			EHRPWM3_A	5	IO									
			GPIO0_54	7	IO									
			UART2_RXD	11	I									
AM36	W31	SPI0_D1 PADCFG: PADCONFIG_55 0x0011C0DC	SPI0_D1	0	IO	1.8 V/3.3 V	Off / Off / Off	Off / Off / Off	7	PU/PD	VDDSHV0	Yes	LVCMOS	No
			MCASP3_AXR2	3	IO									
			EHRPWM4_A	5	IO									
			GPIO0_55	7	IO									
			UART2_TXD	11	O									

Table 5-1. Pin Attributes (ALY, AND Packages) (continued)

ALY Ball Num [1]	AND Ball Num [1]	Ball Name [2] PADCFG Register [15] PADCFG Address [16]	Signal Name [3]	Mux Mode [4]	Signal Type [5]	I/O Voltage [6]	Ball State DURING Reset (RX/TX/PULL) [7]	Ball State AFTER Reset (RX/TX/PULL) [8]	Mux Mode AFTER Reset [9]	Pull Type [10]	Power [11]	Hys [12]	Voltage Buffer Type [13]	IO RET [14]
G35	F21	TCK PADCFG: WKUP_PADCONFIG_73 0x4301C124	TCK	0	I	1.8 V/3.3 V	On / NA / Up	On / Off / Up	0	PU/PD	VDDSHV0_MCU	Yes	LVC MOS	No
AL37	V33	TDI PADCFG: PADCONFIG_69 0x0011C114	TDI	0	I	1.8 V/3.3 V	On / Off / Up	On / Off / Up	0	PU/PD	VDDSHV0	Yes	LVC MOS	No
AL35	W33	TDO PADCFG: PADCONFIG_70 0x0011C118	TDO	0	OZ	1.8 V/3.3 V	Off / Off / Up	Off / SS / Up	0	PU/PD	VDDSHV0	Yes	LVC MOS	No
AR38	AA32	TIMER_IO0 PADCFG: PADCONFIG_58 0x0011C0E8	TIMER_IO0	0	IO	1.8 V/3.3 V	Off / Off / Off	Off / Off / Off	7	PU/PD	VDDSHV0	Yes	LVC MOS	No
			ECAP1_IN_APWM_OUT	1	IO									
			SYSCLKOUT0	2	O									
			UART3_RXD	5	I									
			PCIE1_CLKREQn	6	IO									
			GPIO0_58	7	IO									
			MMC1_SDCD	8	I									
			MCAN13_TX	9	O									
I2C6_SDA	13	IOD												
AN37	W30	TIMER_IO1 PADCFG: PADCONFIG_59 0x0011C0EC	TIMER_IO1	0	IO	1.8 V/3.3 V	Off / Off / Off	Off / Off / Off	7	PU/PD	VDDSHV0	Yes	LVC MOS	No
			ECAP2_IN_APWM_OUT	1	IO									
			OBSCLK0	2	O									
			UART3_TXD	5	O									
			USB0_DRVVBUS	6	O									
			GPIO0_59	7	IO									
			MMC1_SDWP	8	I									
			MCAN13_RX	9	I									
I2C6_SCL	13	IOD												
OBSCLK0	15	O												
AL36	V32	TMS PADCFG: PADCONFIG_71 0x0011C11C	TMS	0	I	1.8 V/3.3 V	On / Off / Up	On / Off / Up	0	PU/PD	VDDSHV0	Yes	LVC MOS	No
G37	F17	TRSTn PADCFG: WKUP_PADCONFIG_74 0x4301C128	TRSTn	0	I	1.8 V/3.3 V	On / NA / Down	On / Off / Down	0	PU/PD	VDDSHV0_MCU	Yes	LVC MOS	No

Table 5-1. Pin Attributes (ALY, AND Packages) (continued)

ALY Ball Num [1]	AND Ball Num [1]	Ball Name [2] PADCFG Register [15] PADCFG Address [16]	Signal Name [3]	Mux Mode [4]	Signal Type [5]	I/O Voltage [6]	Ball State DURING Reset (RX/TX/PULL) [7]	Ball State AFTER Reset (RX/TX/PULL) [8]	Mux Mode AFTER Reset [9]	Pull Type [10]	Power [11]	Hys [12]	Voltage Buffer Type [13]	IO RET [14]
AM7	AJ5	UFS0_REF_CLK	UFS0_REF_CLK	0	I	1.2 V					VDDA_1p8_UFS / VDDA_0P8_UFS		M-PHY	
			UFS0_REF_CLK	16	I									
AM8	AJ7	UFS0_RSTn	UFS0_RSTn	0	I	1.2 V					VDDA_1p8_UFS / VDDA_0P8_UFS		M-PHY	
			UFS0_RSTn	16	I									
AM4	AK5	UFS0_RX_DN0	UFS0_RX_DN0	0	I	1.8 V					VDDA_1p8_UFS / VDDA_0P8_UFS		M-PHY	
			UFS0_RX_DN0	16	I									
AM1	AL4	UFS0_RX_DN1	UFS0_RX_DN1	0	I	1.8 V					VDDA_1p8_UFS / VDDA_0P8_UFS		M-PHY	
			UFS0_RX_DN1	16	I									
AM5	AK6	UFS0_RX_DP0	UFS0_RX_DP0	0	I	1.8 V					VDDA_1p8_UFS / VDDA_0P8_UFS		M-PHY	
			UFS0_RX_DP0	16	I									
AM2	AL5	UFS0_RX_DP1	UFS0_RX_DP1	0	I	1.8 V					VDDA_1p8_UFS / VDDA_0P8_UFS		M-PHY	
			UFS0_RX_DP1	16	I									
AL2	AN2	UFS0_TX_DN0	UFS0_TX_DN0	0	I	1.8 V					VDDA_1p8_UFS / VDDA_0P8_UFS		M-PHY	
			UFS0_TX_DN0	16	I									
AN2	AM3	UFS0_TX_DN1	UFS0_TX_DN1	0	I	1.8 V					VDDA_1p8_UFS / VDDA_0P8_UFS		M-PHY	
			UFS0_TX_DN1	16	I									
AL3	AN3	UFS0_TX_DP0	UFS0_TX_DP0	0	I	1.8 V					VDDA_1p8_UFS / VDDA_0P8_UFS		M-PHY	
			UFS0_TX_DP0	16	I									
AN3	AM4	UFS0_TX_DP1	UFS0_TX_DP1	0	I	1.8 V					VDDA_1p8_UFS / VDDA_0P8_UFS		M-PHY	
			UFS0_TX_DP1	16	I									
AP16	AH16	USB0_DM	USB0_DM		IO	3.3 V					VDDA_0P8_USB / VDDA_1P8_USB / VDDA_3P3_USB		USB2PHY	
AP17	AH17	USB0_DP	USB0_DP		IO	3.3 V					VDDA_0P8_USB / VDDA_1P8_USB / VDDA_3P3_USB		USB2PHY	

Table 5-1. Pin Attributes (ALY, AND Packages) (continued)

ALY Ball Num [1]	AND Ball Num [1]	Ball Name [2] PADCFG Register [15] PADCFG Address [16]	Signal Name [3]	Mux Mode [4]	Signal Type [5]	I/O Voltage [6]	Ball State DURING Reset (RX/TX/PULL) [7]	Ball State AFTER Reset (RX/TX/PULL) [8]	Mux Mode AFTER Reset [9]	Pull Type [10]	Power [11]	Hys [12]	Voltage Buffer Type [13]	IO RET [14]
AN17	AH20	USB0_ID	USB0_ID		A	3.3 V					VDDA_0P8_USB / VDDA_1P8_USB / VDDA_3P3_USB		USB2PHY	
AN18	AH22	USB0_RCALIB	USB0_RCALIB		A	3.3 V					VDDA_0P8_USB / VDDA_1P8_USB / VDDA_3P3_USB		USB2PHY	
AN15	AG19	USB0_VBUS	USB0_VBUS		A	5.0 V					VDDA_0P8_USB / VDDA_1P8_USB / VDDA_3P3_USB		DDR	
AB27, AC24, AF15, AF18, AF21, AG11, AG28, T25	AA22, AD13, AD16, AD19, AE26, AE9, P23, Y25	VDDAR_CORE	VDDAR_CORE		PWR									
AB13, AC16, AC18, AC20, AE12, M21, N23, T15, U20, W14, W21, Y11, Y19	AA14, AA16, AA18, AC10, K19, L21, P13, R18, U12, U19, V17, V9, Y11	VDDAR_CPU	VDDAR_CPU		PWR									
M27, N24	K25, L22	VDDAR_MCU	VDDAR_MCU		PWR									
AJ24	AG22	VDDA_0P8_DSITX	VDDA_0P8_DSITX		PWR									
AJ25	AG23	VDDA_0P8_DSITX_C	VDDA_0P8_DSITX_C		PWR									
AH11	AF9	VDDA_0P8_UFS	VDDA_0P8_UFS		PWR									
AK20	AG17	VDDA_0P8_USB	VDDA_0P8_USB		PWR									
AJ28	AG26	VDDA_0P8_CSIRX2	VDDA_0P8_CSIRX2		PWR									
AJ26, AK26	AG24	VDDA_0P8_CSIRX0_1	VDDA_0P8_CSIRX0_1		PWR									
AE9	AD7	VDDA_0P8_DLL_MMC0	VDDA_0P8_DLL_MMC0		PWR									
U11	P8	VDDA_0P8_PLL_DDR0	VDDA_0P8_PLL_DDR0		PWR									
M14	J11	VDDA_0P8_PLL_DDR1	VDDA_0P8_PLL_DDR1		PWR									
N11		VDDA_0P8_PLL_DDR2	VDDA_0P8_PLL_DDR2		PWR									
M18		VDDA_0P8_PLL_DDR3	VDDA_0P8_PLL_DDR3		PWR									
AJ20, AJ21		VDDA_0P8_SERDES2	VDDA_0P8_SERDES2		PWR									

Table 5-1. Pin Attributes (ALY, AND Packages) (continued)

ALY Ball Num [1]	AND Ball Num [1]	Ball Name [2] PADCFG Register [15] PADCFG Address [16]	Signal Name [3]	Mux Mode [4]	Signal Type [5]	I/O Voltage [6]	Ball State DURING Reset (RX/TX/PULL) [7]	Ball State AFTER Reset (RX/TX/PULL) [8]	Mux Mode AFTER Reset [9]	Pull Type [10]	Power [11]	Hys [12]	Voltage Buffer Type [13]	IO RET [14]
AJ17, AJ18	AG15, AG16	VDDA_0P8_SERDES4	VDDA_0P8_SERDES4		PWR									
AJ12, AJ15, AK13, AK14	AF12, AG10, AG13	VDDA_0P8_SERDES0_1	VDDA_0P8_SERDES0_1		PWR									
AG21, AH20		VDDA_0P8_SERDES_C2	VDDA_0P8_SERDES_C2		PWR									
AG17, AH18	AE15, AF16	VDDA_0P8_SERDES_C4	VDDA_0P8_SERDES_C4		PWR									
AH12, AH13, AH15, AH16	AF10, AF13	VDDA_0P8_SERDES_C0_1	VDDA_0P8_SERDES_C0_1		PWR									
AH24, AH25	AF22, AF23	VDDA_1P8_DSITX	VDDA_1P8_DSITX		PWR									
AJ10	AG8	VDDA_1P8_UFS	VDDA_1P8_UFS		PWR									
AK21	AH19	VDDA_1P8_USB	VDDA_1P8_USB		PWR									
AH29, AJ29	AF27, AG27	VDDA_1P8_CSIRX2	VDDA_1P8_CSIRX2		PWR									
AH27, AH28	AF25, AF26	VDDA_1P8_CSIRX0_1	VDDA_1P8_CSIRX0_1		PWR									
AH21		VDDA_1P8_SERDES2	VDDA_1P8_SERDES2		PWR									
AH17	AF15	VDDA_1P8_SERDES4	VDDA_1P8_SERDES4		PWR									
AJ13, AJ14	AG11, AG12	VDDA_1P8_SERDES0_1	VDDA_1P8_SERDES0_1		PWR									
AJ23	AG21	VDDA_1P8_SERDES2_4	VDDA_1P8_SERDES2_4		PWR									
AJ19	AF17	VDDA_3P3_USB	VDDA_3P3_USB		PWR									
M31	J28	VDDA_ADC0	VDDA_ADC0		PWR									
N30	K28	VDDA_ADC1	VDDA_ADC1		PWR									
M28	K26	VDDA_MCU_PLLGRP0	VDDA_MCU_PLLGRP0		PWR									
M26	K24	VDDA_MCU_TEMP	VDDA_MCU_TEMP		PWR									
N29	L27	VDDA_OSC1	VDDA_OSC1		PWR									
AA27	W25	VDDA_PLLGRP0	VDDA_PLLGRP0		PWR									
Y28	V25	VDDA_PLLGRP1	VDDA_PLLGRP1		PWR									
AG13	AE11	VDDA_PLLGRP2	VDDA_PLLGRP2		PWR									
V14	T12	VDDA_PLLGRP5	VDDA_PLLGRP5		PWR									
R21	N19	VDDA_PLLGRP6	VDDA_PLLGRP6		PWR									
P12	M10	VDDA_PLLGRP7	VDDA_PLLGRP7		PWR									
P15	K13	VDDA_PLLGRP8	VDDA_PLLGRP8		PWR									
Y26	V24	VDDA_PLLGRP9	VDDA_PLLGRP9		PWR									
AG23	AD20	VDDA_PLLGRP10	VDDA_PLLGRP10		PWR									

Table 5-1. Pin Attributes (ALY, AND Packages) (continued)

ALY Ball Num [1]	AND Ball Num [1]	Ball Name [2] PADCFG Register [15] PADCFG Address [16]	Signal Name [3]	Mux Mode [4]	Signal Type [5]	I/O Voltage [6]	Ball State DURING Reset (RX/TX/PULL) [7]	Ball State AFTER Reset (RX/TX/PULL) [8]	Mux Mode AFTER Reset [9]	Pull Type [10]	Power [11]	Hys [12]	Voltage Buffer Type [13]	IO RET [14]
AA23	W21	VDDA_PLLGRP12	VDDA_PLLGRP12		PWR									
AB26	Y24	VDDA_PLLGRP13	VDDA_PLLGRP13		PWR									
N28	L26	VDDA_POR_WKUP	VDDA_POR_WKUP		PWR									
Y27	V26	VDDA_TEMP0	VDDA_TEMP0		PWR									
M12	K10	VDDA_TEMP1	VDDA_TEMP1		PWR									
W23	U21	VDDA_TEMP2	VDDA_TEMP2		PWR									
AE13	AC11	VDDA_TEMP3	VDDA_TEMP3		PWR									
AD18	AB16	VDDA_TEMP4	VDDA_TEMP4		PWR									
K31, L32	J27	VDDA_WKUP	VDDA_WKUP		PWR									
V30, V32, W31	T28	VDDSHV0	VDDSHV0		PWR									
H29, J28, K29	H27	VDDSHV0_MCU	VDDSHV0_MCU		PWR									
H25, J24, K25	G22, H23	VDDSHV1_MCU	VDDSHV1_MCU		PWR									
T30, T32, U31	N28, P28	VDDSHV2	VDDSHV2		PWR									
H27, J26, K27	G24, H25	VDDSHV2_MCU	VDDSHV2_MCU		PWR									
P31, R30, R31	N27	VDDSHV5	VDDSHV5		PWR									
A31, AK1, B1, H11, H13, H15, H17, H19, H9, J10, J12, J14, J16, J18, J8, K11, K13, K15, K17, K19, K9, L10, L12, L14, L16, L18, M9, N10, N8, P9, R10, R8, T9, U10, U8	A2, AH1, G10, G12, G14, G16, G18, H11, H13, H15, H17, H9, J10, J14, J16, J8, K7, L8, M7, P7, R8	VDDSDDR	VDDSDDR		PWR									
T10	N8	VDDSDDR_C0	VDDSDDR_C0		PWR									
L15	J12	VDDSDDR_C1	VDDSDDR_C1		PWR									
M10		VDDSDDR_C2	VDDSDDR_C2		PWR									
L17		VDDSDDR_C3	VDDSDDR_C3		PWR									
AF9, AG10, AG8, AH9	AE8, AF7	VDDSDMMC0	VDDSDMMC0		PWR									

Table 5-1. Pin Attributes (ALY, AND Packages) (continued)

ALY Ball Num [1]	AND Ball Num [1]	Ball Name [2] PADCFG Register [15] PADCFG Address [16]	Signal Name [3]	Mux Mode [4]	Signal Type [5]	I/O Voltage [6]	Ball State DURING Reset (RX/TX/PULL) [7]	Ball State AFTER Reset (RX/TX/PULL) [8]	Mux Mode AFTER Reset [9]	Pull Type [10]	Power [11]	Hys [12]	Voltage Buffer Type [13]	IO RET [14]
AA24, AA26, AA28, AA30, AB25, AB29, AB31, AC26, AC28, AC30, AD25, AD27, AD29, AD31, AE24, AE26, AE28, AE30, AE32, AF13, AF17, AF19, AF23, AF25, AF27, AF29, AF31, AG12, AG14, AG16, AG18, AG20, AG22, AG24, AG26, AG30, AG32, AH31, AJ30, M11, M13, M15, M17, M19, N12, N16, N18, P11, P17, P19, R12, R14, R16, R18, R24, R26, R28, T11, T13, T27, U12, U24, U26, U28, V25, V27, W24, W26, W28, W30, W32, Y25, Y29, Y31	AA24, AA26, AA28, AB23, AB25, AB27, AC22, AC24, AC26, AC28, AD11, AD15, AD17, AD21, AD23, AD25, AD27, AE10, AE12, AE14, AE16, AE18, AE20, AE22, AE24, AE28, AF19, K11, K15, K17, K9, L10, L12, L14, L16, M11, M13, M15, M17, M9, N10, N12, N14, N16, N22, N24, N26, P11, P25, P9, R10, R22, R24, R26, T23, T25, U22, U24, U26, U28, V23, V27, W22, W24, W26, W28, Y23, Y27	VDD_CORE	VDD_CORE		PWR									

Table 5-1. Pin Attributes (ALY, AND Packages) (continued)

ALY Ball Num [1]	AND Ball Num [1]	Ball Name [2] PADCFG Register [15] PADCFG Address [16]	Signal Name [3]	Mux Mode [4]	Signal Type [5]	I/O Voltage [6]	Ball State DURING Reset (RX/TX/PULL) [7]	Ball State AFTER Reset (RX/TX/PULL) [8]	Mux Mode AFTER Reset [9]	Pull Type [10]	Power [11]	Hys [12]	Voltage Buffer Type [13]	IO RET [14]
AA10, AA12, AA14, AA20, AA22, AA8, AB11, AB19, AB21, AB23, AB9, AC10, AC12, AC14, AC22, AD11, AD13, AD15, AD17, AD19, AD21, AD23, AD9, AE10, AE14, AE16, AE18, AE20, AE22, AF11, H21, H23, J20, J22, K21, K23, L20, L22, N20, N22, P21, R20, R22, T17, T19, T21, T23, U14, U22, V11, V13, V19, V21, V23, V9, W10, W12, W20, W22, W8, Y13, Y21, Y23, Y9	AA10, AA12, AA20, AA8, AB11, AB13, AB15, AB17, AB19, AB21, AB9, AC12, AC14, AC16, AC18, AC20, AC8, AD9, H19, H21, J18, J20, L18, L20, M19, N18, N20, P15, P17, P19, P21, R12, R20, T11, T17, T19, T21, T9, U10, U18, U20, U8, V11, V19, V21, W10, W12, W18, W20, W8, Y17, Y19, Y21, Y9	VDD_CPU	VDD_CPU		PWR									
L24, M23, M25, N26, P23, P25, P27	J22, K21, K23, L24, M21, M23, M25	VDD_MCU	VDD_MCU		PWR									
L28	J26	VDD_MCU_WAKE1	VDD_MCU_WAKE1		PWR									
U29	R27	VDD_WAKE0	VDD_WAKE0		PWR									
K28	G26	VMON1_ER_VSYS	VMON1_ER_VSYS		A									
N27	L25	VMON2_IR_VCPU	VMON2_IR_VCPU		A									
J30	K30	VMON3_IR_VEXT1P8	VMON3_IR_VEXT1P8		A									
P28	M26	VMON4_IR_VEXT1P8	VMON4_IR_VEXT1P8		A									

Table 5-1. Pin Attributes (ALY, AND Packages) (continued)

ALY Ball Num [1]	AND Ball Num [1]	Ball Name [2] PADCFG Register [15] PADCFG Address [16]	Signal Name [3]	Mux Mode [4]	Signal Type [5]	I/O Voltage [6]	Ball State DURING Reset (RX/TX/PULL) [7]	Ball State AFTER Reset (RX/TX/PULL) [8]	Mux Mode AFTER Reset [9]	Pull Type [10]	Power [11]	Hys [12]	Voltage Buffer Type [13]	IO RET [14]
R29	M29	VMON5_IR_VEXT3P3	VMON5_IR_VEXT3P3		A									
AA31	V29	VPP_CORE	VPP_CORE		PWR									
L29	F26	VPP_MCU	VPP_MCU		PWR									

Table 5-1. Pin Attributes (ALY, AND Packages) (continued)

ALY Ball Num [1]	AND Ball Num [1]	Ball Name [2] PADCFG Register [15] PADCFG Address [16]	Signal Name [3]	Mux Mode [4]	Signal Type [5]	I/O Voltage [6]	Ball State DURING Reset (RX/TX/PULL) [7]	Ball State AFTER Reset (RX/TX/PULL) [8]	Mux Mode AFTER Reset [9]	Pull Type [10]	Power [11]	Hys [12]	Voltage Buffer Type [13]	IO RET [14]
A1, A10, A12, A15, A2, A20, A23, A25, A28, A34, A37, A5, A7, AA11, AA13, AA19, AA2, AA21, AA25, AA29, AA34, AA36, AA38, AA5, AA9, AB1, AB10, AB12, AB14, AB20, AB22, AB24, AB28, AB30, AB32, AB33, AB35, AB37, AB5, AB8, AC11, AC13, AC15, AC17, AC19, AC2, AC21, AC23, AC25, AC27, AC29, AC31, AC6, AC9, AD1, AD10, AD12, AD14, AD16, AD20, AD22, AD24, AD26, AD28, AD30, AD32, AD35, AD4, AD8, AE11, AE15, AE17, AE19, AE2, AE21, AE23, AE25, AE27, AE30, AE32, AE4, AE7, AF11, AF14,	A1, A23, A25, A27, A29, A31, A4, A7, AA11, AA13, AA15, AA17, AA19, AA2, AA21, AA23, AA25, AA27, AA29, AA31, AA33, AA5, AA9, AB1, AB10, AB12, AB14, AB18, AB20, AB22, AB24, AB28, AB30, AB32, AB28, AB30, AB32, AB4, AB8, AC13, AC15, AC17, AC19, AC2, AC21, AC23, AC25, AC27, AC5, AC9, AD10, AD12, AD14, AD18, AD22, AD24, AD26, AD28, AD29, AD3, AD31, AD33, AD6, AD8, AE1, AE13, AE17, AE19, AE21, AE23, AE25, AE27, AE30, AE32, AE4, AE7, AF11, AF14,	VSS	VSS		GND									

Table 5-1. Pin Attributes (ALY, AND Packages) (continued)

ALY Ball Num [1]	AND Ball Num [1]	Ball Name [2] PADCFG Register [15] PADCFG Address [16]	Signal Name [3]	Mux Mode [4]	Signal Type [5]	I/O Voltage [6]	Ball State DURING Reset (RX/TX/PULL) [7]	Ball State AFTER Reset (RX/TX/PULL) [8]	Mux Mode AFTER Reset [9]	Pull Type [10]	Power [11]	Hys [12]	Voltage Buffer Type [13]	IO RET [14]
AE27, AE29, AE31, AE5, AF10, AF12, AF14, AF16, AF20, AF22, AF24, AF26, AF28, AF3, AF30, AF32, AF6, AF8, AG1, AG15, AG19, AG25, AG27, AG29, AG31, AG4, AG7, AG9, AH10, AH14, AH19, AH2, AH22, AH23, AH26, AH30, AH32, AH35, AH5, AH8, AJ11, AJ16, AJ22, AJ27, AJ3, AJ31, AJ6, AJ8, AJ9, AK10, AK11, AK12, AK15, AK16, AK17, AK18, AK19, AK22, AK23, AK24, AK25, AK27, AK28, AK30, AK32, AL1, AL10, AL12, AL13, AL14, AL15, AL16, AL17,	AF18, AF2, AF20, AF21, AF24, AF28, AF5, AF8, AG14, AG18, AG20, AG25, AG28, AG29, AG3, AG31, AG33, AG6, AG9, AH12, AH15, AH18, AH21, AH24, AH26, AH28, AH30, AH5, AJ11, AJ14, AJ17, AJ20, AJ23, AJ26, AJ29, AJ32, AJ6, AJ8, AK10, AK13, AK16, AK19, AK22, AK25, AK28, AK31, AK4, AK7, AL12, AL15, AL18, AL21, AL24, AL27, AL3, AL30, AL33, AL6, AL9, AM11, AM14, AM17, AM2, AM20, AM23, AM26, AM29, AM32, AM33, AM5, AM8, AN1, AN10, AN13, AN16, AN19, AN22, AN25,													

Table 5-1. Pin Attributes (ALY, AND Packages) (continued)

ALY Ball Num [1]	AND Ball Num [1]	Ball Name [2] PADCFG Register [15] PADCFG Address [16]	Signal Name [3]	Mux Mode [4]	Signal Type [5]	I/O Voltage [6]	Ball State DURING Reset (RX/TX/PULL) [7]	Ball State AFTER Reset (RX/TX/PULL) [8]	Mux Mode AFTER Reset [9]	Pull Type [10]	Power [11]	Hys [12]	Voltage Buffer Type [13]	IO RET [14]
AL18, AL19, AL21, AL26, AL29, AL31, AL4, AM11, AM13, AM15, AM18, AM20, AM23, AM25, AM27, AM3, AM30, AM32, AM38, AM6, AN1, AN10, AN12, AN14, AN16, AN19, AN22, AN25, AN28, AN31, AN34, AN4, AN7, AP12, AP15, AP18, AP21, AP24, AP27, AP3, AP30, AP33, AP36, AP6, AP9, AR1, AR10, AR13, AR16, AR19, AR22, AR25, AR28, AR31, AR34, AR37, AR4, AR7, AT12, AT15, AT18, AT21, AT24, AT27, AT3, AT30, AT33, AT36, AT6, AT9, AU1,	AN28, AN31, AN32, AN4, AN7, B22, B24, B26, B28, B3, B30, B32, B6, C11, C13, C15, C17, C2, C21, C23, C25, C27, C29, C31, C33, C5, D1, D26, D28, D30, D32, D4, D7, E23, E25, E27, E29, E3, E31, E6, E8, F14, F16, F18, F2, F20, F22, F24, F5, F7, G1, G11, G13, G15, G17, G19, G21, G23, G25, G27, G4, G9, H10, H12, H14, H16, H18, H2, H20, H22, H24, H26, H28, H5, H8, J1, J13, J15, J17, J19, J21, J6, J7, J9, K12, K14, K16, K18, K2, K20, K22, K27, K29, K5, K8, L11, L13, L15, L17, L19, L23, L3, L6, L7, L9, M1, M12, M14, M16, M18, M20, M22, M24, M28, M4, M8, N11, N13, N15, N17,													

Table 5-1. Pin Attributes (ALY, AND Packages) (continued)

ALY Ball Num [1]	AND Ball Num [1]	Ball Name [2] PADCFG Register [15] PADCFG Address [16]	Signal Name [3]	Mux Mode [4]	Signal Type [5]	I/O Voltage [6]	Ball State DURING Reset (RX/TX/PULL) [7]	Ball State AFTER Reset (RX/TX/PULL) [8]	Mux Mode AFTER Reset [9]	Pull Type [10]	Power [11]	Hys [12]	Voltage Buffer Type [13]	IO RET [14]
AU10, AU13, AU16, AU19, AU22, AU25, AU28, AU31, AU34, AU37, AU38, AU4, AU7, AV1, AV11, AV14, AV17, AV2, AV20, AV23, AV26, AV29, AV32, AV35, AV5, AV8, B11, B13, B16, B19, B22, B24, B26, B29, B31, B38, B6, B9, C14, C17, C18, C2, C21, C27, C30, C4, C8, D10, D15, D20, D23, D28, D3, D35, D6, D7, E12, E13, E16, E19, E2, E22, E25, E26, E29, E31, E5, E9, F1, F11, F14, F17, F21, F24, F27, F30, F4, F7, F8, G15, G18, G20, G28, G3, G6, H10, H16, H18, H2, H20, H22, H24, H26, H28, H30, H31, H5, H7, H8, J1, J11, J13,	N2, N21, N23, N25, N29, N5, N7, N9, P10, P12, P14, P16, P18, P20, P22, P24, P26, P3, R11, R17, R19, R21, R23, R25, R28, R3, R6, R9, T10, T18, T2, T20, T22, T24, T26, T5, T8, U1, U11, U17, U23, U25, U27, U29, U33, U4, U7, U9, V10, V12, V18, V20, V22, V28, V3, V6, V8, W11, W17, W19, W2, W23, W27, W29, W5, W9, Y1, Y10, Y12, Y18, Y20, Y22, Y26, Y28, Y6, Y8													

Table 5-1. Pin Attributes (ALY, AND Packages) (continued)

ALY Ball Num [1]	AND Ball Num [1]	Ball Name [2] PADCFG Register [15] PADCFG Address [16]	Signal Name [3]	Mux Mode [4]	Signal Type [5]	I/O Voltage [6]	Ball State DURING Reset (RX/TX/PULL) [7]	Ball State AFTER Reset (RX/TX/PULL) [8]	Mux Mode AFTER Reset [9]	Pull Type [10]	Power [11]	Hys [12]	Voltage Buffer Type [13]	IO RET [14]
J15, J17, J19, J21, J23, J25, J27, J29, J32, J4, J9, K10, K12, K14, K16, K18, K2, K20, K22, K24, K26, K6, K8, L1, L11, L13, L19, L21, L23, L31, L5, L9, M16, M2, M20, M22, M24, M29, M30, M32, M5, M8, N15, N17, N19, N21, N25, N3, N31, N32, N38, N6, N9, P1, P10, P16, P18, P20, P22, P24, P26, P30, P32, P35, P37, P4, P7, P8, R11, R13, R15, R17, R19, R2, R23, R25, R27, R32, R34, R36, R38, R5, R9, T12, T14, T16, T18, T20, T22, T24, T26, T28, T3, T31, T33, T35, T37, T6, T8, U13, U19, U21, U23, U25, U27, U3, U30, U32, U34, U36, U38, U6, U9, V10, V12, V2, V20, V22, V24, V26,														

Table 5-1. Pin Attributes (ALY, AND Packages) (continued)

ALY Ball Num [1]	AND Ball Num [1]	Ball Name [2] PADCFG Register [15] PADCFG Address [16]	Signal Name [3]	Mux Mode [4]	Signal Type [5]	I/O Voltage [6]	Ball State DURING Reset (RX/TX/PULL) [7]	Ball State AFTER Reset (RX/TX/PULL) [8]	Mux Mode AFTER Reset [9]	Pull Type [10]	Power [11]	Hys [12]	Voltage Buffer Type [13]	IO RET [14]
V28, V31, V33, V35, V37, V5, V8, W1, W11, W13, W19, W25, W27, W29, W34, W36, W38, W4, W7, W9, Y10, Y12, Y14, Y20, Y22, Y24, Y3, Y30, Y32, Y33, Y35, Y37, Y6, Y8														
H38	E15	WKUP_GPIO0_0 PADCFG: WKUP_PADCONFIG_48 0x4301C0C0	MCU_SPI1_CLK	0	IO	1.8 V/3.3 V	On / Off / Off	On / Off / Off	7	PU/PD	VDDSHV0_MCU	Yes	LVCMOS	Yes
			MCU_SPI1_CLK	1	IO									
			WKUP_GPIO0_0	7	IO									
			MCU_BOOTMODE03	BOOTS TRAP	I									
J34	D16	WKUP_GPIO0_1 PADCFG: WKUP_PADCONFIG_49 0x4301C0C4	MCU_SPI1_D0	0	IO	1.8 V/3.3 V	On / Off / Off	On / Off / Off	7	PU/PD	VDDSHV0_MCU	Yes	LVCMOS	Yes
			MCU_SPI1_D0	1	IO									
			WKUP_GPIO0_1	7	IO									
			MCU_BOOTMODE04	BOOTS TRAP	I									
J35	D18	WKUP_GPIO0_2 PADCFG: WKUP_PADCONFIG_50 0x4301C0C8	MCU_SPI1_D1	0	IO	1.8 V/3.3 V	On / Off / Off	On / Off / Off	7	PU/PD	VDDSHV0_MCU	Yes	LVCMOS	Yes
			MCU_SPI1_D1	1	IO									
			WKUP_GPIO0_2	7	IO									
			MCU_BOOTMODE05	BOOTS TRAP	I									
J36	D19	WKUP_GPIO0_3 PADCFG: WKUP_PADCONFIG_51 0x4301C0CC	MCU_SPI1_CS0	0	IO	1.8 V/3.3 V	Off / Off / Off	Off / Off / Off	7	PU/PD	VDDSHV0_MCU	Yes	LVCMOS	Yes
			MCU_SPI1_CS0	1	IO									
			WKUP_GPIO0_3	7	IO									
H35	E16	WKUP_GPIO0_4 PADCFG: WKUP_PADCONFIG_52 0x4301C0D0	MCU_MCAN1_TX	0	O	1.8 V/3.3 V	Off / Off / Off	Off / Off / Off	7	PU/PD	VDDSHV0_MCU	Yes	LVCMOS	Yes
			MCU_MCAN1_TX	1	O									
			MCU_SPI0_CS3	2	IO									
			MCU_ADC_EXT_TRIGGER0	3	I									
			WKUP_GPIO0_4	7	IO									

Table 5-1. Pin Attributes (ALY, AND Packages) (continued)

ALY Ball Num [1]	AND Ball Num [1]	Ball Name [2] PADCFG Register [15] PADCFG Address [16]	Signal Name [3]	Mux Mode [4]	Signal Type [5]	I/O Voltage [6]	Ball State DURING Reset (RX/TX/PULL) [7]	Ball State AFTER Reset (RX/TX/PULL) [8]	Mux Mode AFTER Reset [9]	Pull Type [10]	Power [11]	Hys [12]	Voltage Buffer Type [13]	IO RET [14]
K36	D20	WKUP_GPIO0_5 PADCFG: WKUP_PADCONFIG_53 0x4301C0D4	MCU_MCAN1_RX	0	I	1.8 V/3.3 V	Off / Off / Off	Off / Off / Off	7	PU/PD	VDDSHV0_MCU	Yes	LVCMOS	Yes
			MCU_MCAN1_RX	1	I									
			MCU_SPI1_CS3	2	IO									
			MCU_ADC_EXT_TRIGGER1	3	I									
			WKUP_GPIO0_5	7	IO									
L37	B15	WKUP_GPIO0_6 PADCFG: WKUP_PADCONFIG_54 0x4301C0D8	WKUP_UART0_CTSn	0	I	1.8 V/3.3 V	Off / Off / Off	Off / Off / Off	7	PU/PD	VDDSHV0_MCU	Yes	LVCMOS	Yes
			WKUP_UART0_CTSn	1	I									
			MCU_CPTS0_HW1TSPUSH	2	I									
			MCU_I2C1_SCL	3	IOD									
L36	B17	WKUP_GPIO0_7 PADCFG: WKUP_PADCONFIG_55 0x4301C0DC	WKUP_UART0_RTSn	0	O	1.8 V/3.3 V	Off / Off / Off	Off / Off / Off	7	PU/PD	VDDSHV0_MCU	Yes	LVCMOS	Yes
			WKUP_UART0_RTSn	1	O									
			MCU_CPTS0_HW2TSPUSH	2	I									
			MCU_I2C1_SDA	3	IOD									
L35	B19	WKUP_GPIO0_8 PADCFG: WKUP_PADCONFIG_56 0x4301C0E0	MCU_I2C1_SCL	0	IOD	1.8 V/3.3 V	Off / Off / Off	Off / Off / Off	7	PU/PD	VDDSHV0_MCU	Yes	LVCMOS	Yes
			MCU_I2C1_SCL	1	IOD									
			MCU_CPTS0_TS_SYNC	2	O									
			MCU_I3C0_SCL	3	IO									
			MCU_TIMER_IO6	4	IO									
WKUP_GPIO0_8	7	IO												
L34	A15	WKUP_GPIO0_9 PADCFG: WKUP_PADCONFIG_57 0x4301C0E4	MCU_I2C1_SDA	0	IOD	1.8 V/3.3 V	Off / Off / Off	Off / Off / Off	7	PU/PD	VDDSHV0_MCU	Yes	LVCMOS	Yes
			MCU_I2C1_SDA	1	IOD									
			MCU_CPTS0_TS_COMP	2	O									
			MCU_I3C0_SDA	3	IO									
			MCU_TIMER_IO7	4	IO									
WKUP_GPIO0_9	7	IO												
L33	B18	WKUP_GPIO0_10 PADCFG: WKUP_PADCONFIG_58 0x4301C0E8	MCU_EXT_REFCLK0	0	I	1.8 V/3.3 V	Off / Off / Off	Off / Off / Off	7	PU/PD	VDDSHV0_MCU	Yes	LVCMOS	Yes
			MCU_EXT_REFCLK0	1	I									
			MCU_UART0_TXD	2	O									
			MCU_ADC_EXT_TRIGGER0	3	I									
			MCU_CPTS0_RFT_CLK	4	I									
			MCU_SYSCLKOUT0	5	O									
			WKUP_GPIO0_10	7	IO									

Table 5-1. Pin Attributes (ALY, AND Packages) (continued)

ALY Ball Num [1]	AND Ball Num [1]	Ball Name [2] PADCFG Register [15] PADCFG Address [16]	Signal Name [3]	Mux Mode [4]	Signal Type [5]	I/O Voltage [6]	Ball State DURING Reset (RX/TX/PULL) [7]	Ball State AFTER Reset (RX/TX/PULL) [8]	Mux Mode AFTER Reset [9]	Pull Type [10]	Power [11]	Hys [12]	Voltage Buffer Type [13]	IO RET [14]
M38	B21	WKUP_GPIO0_11 PADCFG: WKUP_PADCONFIG_59 0x4301C0EC	MCU_OBSCLK0	0	O	1.8 V/3.3 V	Off / Off / Off	Off / Off / Off	7	PU/PD	VDDSHV0_MCU	Yes	LVCMOS	Yes
			MCU_OBSCLK0	1	O									
			MCU_UART0_RXD	2	I									
			MCU_ADC_EXT_TRIGGER1	3	I									
			MCU_TIMER_IO1	4	IO									
			MCU_I3C0_SDAPULLEN	5	OD									
			MCU_CLKOUT0	6	OZ									
WKUP_GPIO0_11	7	IO												
J37	D17	WKUP_GPIO0_12 PADCFG: WKUP_PADCONFIG_60 0x4301C0F0	MCU_UART0_TXD	0	O	1.8 V/3.3 V	On / Off / Off	On / Off / Off	7	PU/PD	VDDSHV0_MCU	Yes	LVCMOS	Yes
			MCU_SPI0_CS1	1	IO									
			WKUP_GPIO0_12	7	IO									
			MCU_BOOTMODE08		BOOTS TRAP									
K38	D21	WKUP_GPIO0_13 PADCFG: WKUP_PADCONFIG_61 0x4301C0F4	MCU_UART0_RXD	0	I	1.8 V/3.3 V	On / Off / Off	On / Off / Off	7	PU/PD	VDDSHV0_MCU	Yes	LVCMOS	Yes
			MCU_SPI1_CS1	1	IO									
			WKUP_GPIO0_13	7	IO									
			MCU_BOOTMODE09		BOOTS TRAP									
H37	D15	WKUP_GPIO0_14 PADCFG: WKUP_PADCONFIG_62 0x4301C0F8	MCU_UART0_CTSn	0	I	1.8 V/3.3 V	On / Off / Off	On / Off / Off	7	PU/PD	VDDSHV0_MCU	Yes	LVCMOS	Yes
			MCU_SPI0_CS2	1	IO									
			MCU_TIMER_IO8	4	IO									
			WKUP_GPIO0_14	7	IO									
K37	C16	WKUP_GPIO0_15 PADCFG: WKUP_PADCONFIG_63 0x4301C0FC	MCU_UART0_RTSn	0	O	1.8 V/3.3 V	On / Off / Off	On / Off / Off	7	PU/PD	VDDSHV0_MCU	Yes	LVCMOS	Yes
			MCU_SPI1_CS2	1	IO									
			MCU_TIMER_IO9	4	IO									
			WKUP_GPIO0_15	7	IO									
M33	A20	WKUP_GPIO0_49 PADCFG: WKUP_PADCONFIG_100 0x4301C190	PMIC_WAKE1n	0	O	1.8 V/3.3 V	Off / Off / Off	Off / Off / Off	7	PU/PD	VDDSHV0_MCU	Yes	LVCMOS	No
			MCU_EXT_REFCLK0	1	I									
			MCU_CPTS0_RFT_CLK	2	I									
			WKUP_GPIO0_49	7	IO									
M37	A19	WKUP_GPIO0_56 PADCFG: WKUP_PADCONFIG_72 0x4301C120	MCU_TIMER_IO6	4	IO	1.8 V/3.3 V	On / Off / Off	On / Off / Off	7	PU/PD	VDDSHV0_MCU	Yes	LVCMOS	No
			WKUP_GPIO0_56	7	IO									
			BOOTMODE04		BOOTS TRAP									

Table 5-1. Pin Attributes (ALY, AND Packages) (continued)

ALY Ball Num [1]	AND Ball Num [1]	Ball Name [2] PADCFG Register [15] PADCFG Address [16]	Signal Name [3]	Mux Mode [4]	Signal Type [5]	I/O Voltage [6]	Ball State DURING Reset (RX/TX/PULL) [7]	Ball State AFTER Reset (RX/TX/PULL) [8]	Mux Mode AFTER Reset [9]	Pull Type [10]	Power [11]	Hys [12]	Voltage Buffer Type [13]	IO RET [14]
M36	B20	WKUP_GPIO0_57 PADCFG: WKUP_PADCONFIG_95 0x4301C17C	MCU_TIMER_I07	4	IO	1.8 V/3.3 V	On / Off / Off	On / Off / Off	7	PU/PD	VDDSHV0_MCU	Yes	LVCMOS	No
			WKUP_GPIO0_57	7	IO									
			BOOTMODE05	BOOTS TRAP	I									
N34	A17	WKUP_GPIO0_66 PADCFG: WKUP_PADCONFIG_96 0x4301C180	WKUP_GPIO0_66	7	IO	1.8 V/3.3 V	On / Off / Off	On / Off / Off	7	PU/PD	VDDSHV0_MCU	Yes	LVCMOS	Yes
			BOOTMODE06	BOOTS TRAP	I									
M34	A18	WKUP_GPIO0_67 PADCFG: WKUP_PADCONFIG_97 0x4301C184	WKUP_LF_CLKIN	1	I	1.8 V/3.3 V	On / Off / Off	On / Off / Off	7	PU/PD	VDDSHV0_MCU	Yes	LVCMOS	Yes
			WKUP_GPIO0_67	7	IO									
			BOOTMODE07	BOOTS TRAP	I									
N33	A16	WKUP_I2C0_SCL PADCFG: WKUP_PADCONFIG_64 0x4301C100	WKUP_I2C0_SCL	0	I/O	1.8 V/3.3 V	Off / Off / Off	On / SS / Off	0		VDDSHV0_MCU	Yes	I2C OPEN DRAIN	Yes
			WKUP_GPIO0_63	7	IO									
N35	D23	WKUP_I2C0_SDA PADCFG: WKUP_PADCONFIG_65 0x4301C104	WKUP_I2C0_SDA	0	I/O	1.8 V/3.3 V	Off / Off / Off	On / SS / Off	0		VDDSHV0_MCU	Yes	I2C OPEN DRAIN	Yes
			WKUP_GPIO0_64	7	IO									
T38	A24	WKUP_OSC0_XI	WKUP_OSC0_XI		I	1.8 V					VDDA_WKU_P	Yes	HFXOSC	No
U37	B25	WKUP_OSC0_XO	WKUP_OSC0_XO		O	1.8 V					VDDA_WKU_P	Yes	HFXOSC	No
K35	C20	WKUP_UART0_RXD PADCFG: WKUP_PADCONFIG_44 0x4301C0B0	WKUP_UART0_RXD	0	I	1.8 V/3.3 V	Off / Off / Off	Off / Off / Off	7	PU/PD	VDDSHV0_MCU	Yes	LVCMOS	Yes
			WKUP_GPIO0_58	7	IO									
K34	C19	WKUP_UART0_TXD PADCFG: WKUP_PADCONFIG_45 0x4301C0B4	WKUP_UART0_TXD	0	O	1.8 V/3.3 V	Off / Off / Off	Off / Off / Off	7	PU/PD	VDDSHV0_MCU	Yes	LVCMOS	Yes
			WKUP_GPIO0_59	7	IO									

- (1) The MUXMODE field is not used to select the multiplexed signal function for this pin. For more information, see *ADC Integration Details* section in *Device Configuration* chapter of the device TRM.

5.3 Signal Descriptions

1. **SIGNAL NAME:** The name of the signal passing through the pin.

Note

Signal names and descriptions provided in each Signal Descriptions table, represent the pin multiplexed signal function which is implemented at the pin and selected via PADCONFIG registers. Device subsystems may provide secondary multiplexing of signal functions, which are not described in these tables. For more information on secondary multiplexed signal functions, see the respective peripheral chapter of the device TRM.

2. **PIN TYPE:** Signal direction and type:

- I = Input
- O = Output
- OD = Output, with open-drain output function
- IO = Input, Output, or simultaneously Input and Output
- IOD = Input, Output, or simultaneously Input and Output with open-drain output function
- IOZ = Input, Output, or simultaneously Input and Output with three-state output function
- OZ = Output with three-state output function
- A = Analog
- PWR = Power
- GND = Ground
- CAP = LDO Capacitor

3. **DESCRIPTION:** Description of the signal

4. **BALL:** Ball number(s) associated with signal

For more information on the IO cell configurations, see the *Pad Configuration Registers* section in *Device Configuration* chapter of the device TRM.

5.3.1 ADC

5.3.1.1 MCU Domain

Table 5-2. MCU_ADC Signal Descriptions

SIGNAL NAME [1]	PIN TYPE [2]	DESCRIPTION [3]	ALY PIN [4]	AND PIN [4]
MCU_ADC_EXT_TRIGGER0	I	ADC Trigger Input	E38, H35, L33	A12, B18, E16
MCU_ADC_EXT_TRIGGER1	I	ADC Trigger Input	E37, K36, M38	B12, B21, D20

Table 5-3. MCU_ADC0 Signal Descriptions

SIGNAL NAME [1]	PIN TYPE [2]	DESCRIPTION [3]	ALY PIN [4]	AND PIN [4]
MCU_ADC0_REFN	A	ADC Reference (Negative)	U35	C26
MCU_ADC0_REFP	A	ADC Reference (Positive)	R35	D25
MCU_ADC0_AIN0	A	ADC Input 0	P36	E26
MCU_ADC0_AIN1	A	ADC Input 1	V36	F25
MCU_ADC0_AIN2	A	ADC Input 2	T34	F23
MCU_ADC0_AIN3	A	ADC Input 3	T36	A28
MCU_ADC0_AIN4	A	ADC Input 4	P34	E24
MCU_ADC0_AIN5	A	ADC Input 5	R37	D27
MCU_ADC0_AIN6	A	ADC Input 6	R33	A26
MCU_ADC0_AIN7	A	ADC Input 7	V38	B27

Table 5-4. MCU_ADC1 Signal Descriptions

SIGNAL NAME [1]	PIN TYPE [2]	DESCRIPTION [3]	ALY PIN [4]	AND PIN [4]
MCU_ADC1_REFN	A	ADC Reference (Negative)	W35	D29
MCU_ADC1_REFP	A	ADC Reference (Positive)	AA35	C30
MCU_ADC1_AIN0	A	ADC Input 0	Y38	C32
MCU_ADC1_AIN1	A	ADC Input 1	Y34	B33
MCU_ADC1_AIN2	A	ADC Input 2	V34	B31
MCU_ADC1_AIN3	A	ADC Input 3	W37	B29
MCU_ADC1_AIN4	A	ADC Input 4	AA37	D31
MCU_ADC1_AIN5	A	ADC Input 5	W33	A32
MCU_ADC1_AIN6	A	ADC Input 6	U33	A30
MCU_ADC1_AIN7	A	ADC Input 7	Y36	C28

5.3.2 DDRSS**5.3.2.1 MAIN Domain****Table 5-5. DDRSS0 Signal Descriptions**

SIGNAL NAME [1] ⁽²⁾	PIN TYPE [2]	DESCRIPTION [3]	ALY PIN [4]	AND PIN [4]
DDR0_CKN	IO	DDRSS Differential Clock (negative)	AB2	Y2
DDR0_CKP	IO	DDRSS Differential Clock (positive)	AC1	AA1
DDR0_RESETn	IO	DDRSS Reset	AD5	W7
DDR0_RET	I	DDR Retention Enable	AC8	AC7
DDR0_CA0	IO	DDRSS Command Address	AD2	AA3
DDR0_CA1	IO	DDRSS Command Address	AC5	Y4
DDR0_CA2	IO	DDRSS Command Address	AB4	AA4
DDR0_CA3	IO	DDRSS Command Address	AC4	AB3
DDR0_CA4	IO	DDRSS Command Address	AB3	Y3
DDR0_CA5	IO	DDRSS Command Address	AC3	AB5
DDR0_CAL0 ⁽¹⁾	A	IO Pad Calibration Resistor	AE8	R7
DDR0_CKE0	IO	DDRSS Clock Enable	AB6	AB6
DDR0_CKE1	IO	DDRSS Clock Enable	AD3	AB7
DDR0_CSn0_0	IO	DDRSS Chip Select	AD7	AA6
DDR0_CSn0_1	IO	DDRSS Chip Select	AC7	Y5
DDR0_CSn1_0	IO	DDRSS Chip Select	AB7	Y7
DDR0_CSn1_1	IO	DDRSS Chip Select	AD6	AA7
DDR0_DM0	IO	DDRSS Data Mask	V3	U6
DDR0_DM1	IO	DDRSS Data Mask	AA4	V2
DDR0_DM2	IO	DDRSS Data Mask	AG2	AE2
DDR0_DM3	IO	DDRSS Data Mask	AJ5	AF6
DDR0_DQ0	IO	DDRSS Data	U2	R5
DDR0_DQ1	IO	DDRSS Data	U4	R4
DDR0_DQ2	IO	DDRSS Data	W6	R2
DDR0_DQ3	IO	DDRSS Data	W5	T4
DDR0_DQ4	IO	DDRSS Data	V4	U5
DDR0_DQ5	IO	DDRSS Data	V7	T3
DDR0_DQ6	IO	DDRSS Data	U5	T6
DDR0_DQ7	IO	DDRSS Data	V6	T7
DDR0_DQ8	IO	DDRSS Data	Y2	V4

Table 5-5. DDRSS0 Signal Descriptions (continued)

SIGNAL NAME [1] (2)	PIN TYPE [2]	DESCRIPTION [3]	ALY PIN [4]	AND PIN [4]
DDR0_DQ9	IO	DDRSS Data	W3	V7
DDR0_DQ10	IO	DDRSS Data	AA3	W3
DDR0_DQ11	IO	DDRSS Data	W2	V5
DDR0_DQ12	IO	DDRSS Data	AA6	W6
DDR0_DQ13	IO	DDRSS Data	Y4	U2
DDR0_DQ14	IO	DDRSS Data	Y5	W4
DDR0_DQ15	IO	DDRSS Data	AA7	U3
DDR0_DQ16	IO	DDRSS Data	AF2	AD5
DDR0_DQ17	IO	DDRSS Data	AE7	AC3
DDR0_DQ18	IO	DDRSS Data	AG3	AE3
DDR0_DQ19	IO	DDRSS Data	AF5	AB2
DDR0_DQ20	IO	DDRSS Data	AE6	AC4
DDR0_DQ21	IO	DDRSS Data	AF4	AD2
DDR0_DQ22	IO	DDRSS Data	AE3	AC6
DDR0_DQ23	IO	DDRSS Data	AE4	AD4
DDR0_DQ24	IO	DDRSS Data	AG5	AG4
DDR0_DQ25	IO	DDRSS Data	AH3	AG2
DDR0_DQ26	IO	DDRSS Data	AJ2	AF3
DDR0_DQ27	IO	DDRSS Data	AH4	AE5
DDR0_DQ28	IO	DDRSS Data	AJ4	AE6
DDR0_DQ29	IO	DDRSS Data	AH6	AG5
DDR0_DQ30	IO	DDRSS Data	AH7	AF4
DDR0_DQ31	IO	DDRSS Data	AG6	AH6
DDR0_QS0N	IO	DDRSS Complimentary Data Strobe	V1	T1
DDR0_QS0P	IO	DDRSS Data Strobe	U1	R1
DDR0_QS1N	IO	DDRSS Complimentary Data Strobe	Y1	W1
DDR0_QS1P	IO	DDRSS Data Strobe	AA1	V1
DDR0_QS2N	IO	DDRSS Complimentary Data Strobe	AE1	AC1
DDR0_QS2P	IO	DDRSS Data Strobe	AF1	AD1
DDR0_QS3N	IO	DDRSS Complimentary Data Strobe	AH1	AF1
DDR0_QS3P	IO	DDRSS Data Strobe	AJ1	AG1

- (1) An external 240 Ω ±1% resistor must be connected between this pin and VSS. No external voltage should be applied to this pin.
(2) DDRSS0, DDRSS1, DDRSS2, and DDRSS3 must always be used in incremental order. For instance, when using a single LPDDR component, it must be connected to the DDR0_* interface. When using two LPDDR components, they must be connected to DDR0_* and DDR1_* interfaces, and so forth.

Table 5-6. DDRSS1 Signal Descriptions

SIGNAL NAME [1] (2)	PIN TYPE [2]	DESCRIPTION [3]	ALY PIN [4]	AND PIN [4]
DDR1_CKN	IO	DDRSS Differential Clock (negative)	A11	H1
DDR1_CKP	IO	DDRSS Differential Clock (positive)	B10	J2
DDR1_RESETn	IO	DDRSS Reset	G10	G5
DDR1_RET	I	DDR Retention Enable	G8	G8
DDR1_CA0	IO	DDRSS Command Address	F12	J4
DDR1_CA1	IO	DDRSS Command Address	C12	H3
DDR1_CA2	IO	DDRSS Command Address	B12	G2
DDR1_CA3	IO	DDRSS Command Address	C11	J3

Table 5-6. DDRSS1 Signal Descriptions (continued)

SIGNAL NAME [1] ⁽²⁾	PIN TYPE [2]	DESCRIPTION [3]	ALY PIN [4]	AND PIN [4]
DDR1_CA4	IO	DDRSS Command Address	D12	G3
DDR1_CA5	IO	DDRSS Command Address	E10	H4
DDR1_CAL0 ⁽¹⁾	A	IO Pad Calibration Resistor	G14	F8
DDR1_CKE0	IO	DDRSS Clock Enable	D11	E7
DDR1_CKE1	IO	DDRSS Clock Enable	C10	H6
DDR1_CSn0_0	IO	DDRSS Chip Select	E11	G6
DDR1_CSn0_1	IO	DDRSS Chip Select	G11	G7
DDR1_CSn1_0	IO	DDRSS Chip Select	F10	H7
DDR1_CSn1_1	IO	DDRSS Chip Select	G12	F6
DDR1_DM0	IO	DDRSS Data Mask	E17	A3
DDR1_DM1	IO	DDRSS Data Mask	C15	F3
DDR1_DM2	IO	DDRSS Data Mask	D8	L2
DDR1_DM3	IO	DDRSS Data Mask	C1	P2
DDR1_DQ0	IO	DDRSS Data	F16	A6
DDR1_DQ1	IO	DDRSS Data	G16	C6
DDR1_DQ2	IO	DDRSS Data	F15	A5
DDR1_DQ3	IO	DDRSS Data	E15	C4
DDR1_DQ4	IO	DDRSS Data	D16	B4
DDR1_DQ5	IO	DDRSS Data	C16	B2
DDR1_DQ6	IO	DDRSS Data	B17	C3
DDR1_DQ7	IO	DDRSS Data	D17	B5
DDR1_DQ8	IO	DDRSS Data	B15	E5
DDR1_DQ9	IO	DDRSS Data	B14	D2
DDR1_DQ10	IO	DDRSS Data	C13	E2
DDR1_DQ11	IO	DDRSS Data	D13	F4
DDR1_DQ12	IO	DDRSS Data	F13	D6
DDR1_DQ13	IO	DDRSS Data	G13	E4
DDR1_DQ14	IO	DDRSS Data	E14	D3
DDR1_DQ15	IO	DDRSS Data	D14	D5
DDR1_DQ16	IO	DDRSS Data	E8	M3
DDR1_DQ17	IO	DDRSS Data	G9	K4
DDR1_DQ18	IO	DDRSS Data	F9	M2
DDR1_DQ19	IO	DDRSS Data	D9	L5
DDR1_DQ20	IO	DDRSS Data	C9	J5
DDR1_DQ21	IO	DDRSS Data	B8	K3
DDR1_DQ22	IO	DDRSS Data	B7	L4
DDR1_DQ23	IO	DDRSS Data	C7	K6
DDR1_DQ24	IO	DDRSS Data	B2	N6
DDR1_DQ25	IO	DDRSS Data	B3	P4
DDR1_DQ26	IO	DDRSS Data	B4	N3
DDR1_DQ27	IO	DDRSS Data	B5	M5
DDR1_DQ28	IO	DDRSS Data	A6	M6
DDR1_DQ29	IO	DDRSS Data	C5	P5
DDR1_DQ30	IO	DDRSS Data	C6	N4
DDR1_DQ31	IO	DDRSS Data	C3	P6

Table 5-6. DDRSS1 Signal Descriptions (continued)

SIGNAL NAME [1] (2)	PIN TYPE [2]	DESCRIPTION [3]	ALY PIN [4]	AND PIN [4]
DDR1_DQS0N	IO	DDRSS Complimentary Data Strobe	A17	C1
DDR1_DQS0P	IO	DDRSS Data Strobe	A16	B1
DDR1_DQS1N	IO	DDRSS Complimentary Data Strobe	A14	F1
DDR1_DQS1P	IO	DDRSS Data Strobe	A13	E1
DDR1_DQS2N	IO	DDRSS Complimentary Data Strobe	A9	K1
DDR1_DQS2P	IO	DDRSS Data Strobe	A8	L1
DDR1_DQS3N	IO	DDRSS Complimentary Data Strobe	A4	N1
DDR1_DQS3P	IO	DDRSS Data Strobe	A3	P1

- (1) An external 240 Ω \pm 1% resistor must be connected between this pin and VSS. No external voltage should be applied to this pin.
- (2) DDRSS0, DDRSS1, DDRSS2, and DDRSS3 must always be used in incremental order. For instance, when using a single LPDDR component, it must be connected to the DDR0_* interface. When using two LPDDR components, they must be connected to DDR0_* and DDR1_* interfaces, and so forth.

Table 5-7. DDRSS2 Signal Descriptions

SIGNAL NAME [1] (3) (2)	PIN TYPE [2]	DESCRIPTION [3]	ALY PIN [4]	AND PIN [4]
DDR2_CKN	IO	DDRSS Differential Clock (negative)	K1	
DDR2_CKP	IO	DDRSS Differential Clock (positive)	L2	
DDR2_RESETh	IO	DDRSS Reset	J5	
DDR2_RET	I	DDR Retention Enable	L8	
DDR2_CA0	IO	DDRS Command Address	K3	
DDR2_CA1	IO	DDRS Command Address	L3	
DDR2_CA2	IO	DDRS Command Address	K5	
DDR2_CA3	IO	DDRS Command Address	L4	
DDR2_CA4	IO	DDRS Command Address	K4	
DDR2_CA5	IO	DDRS Command Address	L7	
DDR2_CAL0 (1)	A	DDRSS IO Pad Calibration Resistor	U7	
DDR2_CKE0	IO	DDR Clock Enable	L6	
DDR2_CKE1	IO	DDR Clock Enable	J2	
DDR2_CSn0_0	IO	DDRSS Chip Select	J3	
DDR2_CSn0_1	IO	DDRSS Chip Select	J6	
DDR2_CSn1_0	IO	DDRSS Chip Select	J7	
DDR2_CSn1_1	IO	DDRSS Chip Select	K7	
DDR2_DM0	IO	DDRSS Data Mask	T2	
DDR2_DM1	IO	DDRSS Data Mask	M6	
DDR2_DM2	IO	DDRSS Data Mask	G4	
DDR2_DM3	IO	DDRSS Data Mask	D5	
DDR2_DQ0	IO	DDRSS Data	T4	
DDR2_DQ1	IO	DDRSS Data	R6	
DDR2_DQ2	IO	DDRSS Data	R3	
DDR2_DQ3	IO	DDRSS Data	R4	
DDR2_DQ4	IO	DDRSS Data	P6	
DDR2_DQ5	IO	DDRSS Data	P5	
DDR2_DQ6	IO	DDRSS Data	T5	
DDR2_DQ7	IO	DDRSS Data	R7	
DDR2_DQ8	IO	DDRSS Data	N2	
DDR2_DQ9	IO	DDRSS Data	N4	

Table 5-7. DDRSS2 Signal Descriptions (continued)

SIGNAL NAME [1] ⁽³⁾ ⁽²⁾	PIN TYPE [2]	DESCRIPTION [3]	ALY PIN [4]	AND PIN [4]
DDR2_DQ10	IO	DDRSS Data	P2	
DDR2_DQ11	IO	DDRSS Data	P3	
DDR2_DQ12	IO	DDRSS Data	M7	
DDR2_DQ13	IO	DDRSS Data	N5	
DDR2_DQ14	IO	DDRSS Data	M4	
DDR2_DQ15	IO	DDRSS Data	M3	
DDR2_DQ16	IO	DDRSS Data	F3	
DDR2_DQ17	IO	DDRSS Data	G7	
DDR2_DQ18	IO	DDRSS Data	H6	
DDR2_DQ19	IO	DDRSS Data	H4	
DDR2_DQ20	IO	DDRSS Data	G2	
DDR2_DQ21	IO	DDRSS Data	H3	
DDR2_DQ22	IO	DDRSS Data	G5	
DDR2_DQ23	IO	DDRSS Data	F2	
DDR2_DQ24	IO	DDRSS Data	E4	
DDR2_DQ25	IO	DDRSS Data	D2	
DDR2_DQ26	IO	DDRSS Data	F6	
DDR2_DQ27	IO	DDRSS Data	F5	
DDR2_DQ28	IO	DDRSS Data	E3	
DDR2_DQ29	IO	DDRSS Data	E7	
DDR2_DQ30	IO	DDRSS Data	E6	
DDR2_DQ31	IO	DDRSS Data	D4	
DDR2_QS0N	IO	DDRS Complimentary Data Strobe	R1	
DDR2_QS0P	IO	DDRS Data Strobe	T1	
DDR2_QS1N	IO	DDRS Complimentary Data Strobe	M1	
DDR2_QS1P	IO	DDRS Data Strobe	N1	
DDR2_QS2N	IO	DDRS Complimentary Data Strobe	G1	
DDR2_QS2P	IO	DDRS Data Strobe	H1	
DDR2_QS3N	IO	DDRS Complimentary Data Strobe	D1	
DDR2_QS3P	IO	DDRS Data Strobe	E1	

- (1) An external 240 Ω \pm 1% resistor must be connected between this pin and VSS. No external voltage should be applied to this pin.
- (2) DDRSS0, DDRSS1, DDRSS2, and DDRSS3 must always be used in incremental order. For instance, when using a single LPDDR component, it must be connected to the DDR0_* interface. When using two LPDDR components, they must be connected to DDR0_* and DDR1_* interfaces, and so forth.
- (3) DDRSS2, DDRSS3, and SERDES2 are not available on the 27mm package variant of this SoC. DDRSS2/DDRSS3/SERDES2 should be avoided if software compatibility is desired with systems that use the 27mm package.

Table 5-8. DDRSS3 Signal Descriptions

SIGNAL NAME [1] ⁽³⁾ ⁽²⁾	PIN TYPE [2]	DESCRIPTION [3]	ALY PIN [4]	AND PIN [4]
DDR3_CKN	IO	DDRSS Differential Clock (negative)	B25	
DDR3_CKP	IO	DDRSS Differential Clock (positive)	A24	
DDR3_RESETn	IO	DDRSS Reset	C23	
DDR3_RET	I	DDR Retention Enable	G27	
DDR3_CA0	IO	DDRSS Command Address	D25	
DDR3_CA1	IO	DDRSS Command Address	B23	
DDR3_CA2	IO	DDRSS Command Address	D24	
DDR3_CA3	IO	DDRSS Command Address	C24	

Table 5-8. DDRSS3 Signal Descriptions (continued)

SIGNAL NAME [1] ⁽³⁾ ⁽²⁾	PIN TYPE [2]	DESCRIPTION [3]	ALY PIN [4]	AND PIN [4]
DDR3_CA4	IO	DDRSS Command Address	E23	
DDR3_CA5	IO	DDRSS Command Address	F23	
DDR3_CAL0 ⁽¹⁾	A	DDRSS IO Pad Calibration Resistor	F18	
DDR3_CKE0	IO	DDRSS Clock Enable	C25	
DDR3_CKE1	IO	DDRSS Clock Enable	G24	
DDR3_CSn0_0	IO	DDRSS Chip Select	G23	
DDR3_CSn0_1	IO	DDRSS Chip Select	G25	
DDR3_CSn1_0	IO	DDRSS Chip Select	F25	
DDR3_CSn1_1	IO	DDRSS Chip Select	E24	
DDR3_DM0	IO	DDRSS Data Mask	E18	
DDR3_DM1	IO	DDRSS Data Mask	D21	
DDR3_DM2	IO	DDRSS Data Mask	C28	
DDR3_DM3	IO	DDRSS Data Mask	E30	
DDR3_DQ0	IO	DDRSS Data	D18	
DDR3_DQ1	IO	DDRSS Data	B18	
DDR3_DQ2	IO	DDRSS Data	C19	
DDR3_DQ3	IO	DDRSS Data	D19	
DDR3_DQ4	IO	DDRSS Data	F20	
DDR3_DQ5	IO	DDRSS Data	E20	
DDR3_DQ6	IO	DDRSS Data	G19	
DDR3_DQ7	IO	DDRSS Data	F19	
DDR3_DQ8	IO	DDRSS Data	E21	
DDR3_DQ9	IO	DDRSS Data	G21	
DDR3_DQ10	IO	DDRSS Data	F22	
DDR3_DQ11	IO	DDRSS Data	D22	
DDR3_DQ12	IO	DDRSS Data	C22	
DDR3_DQ13	IO	DDRSS Data	B21	
DDR3_DQ14	IO	DDRSS Data	B20	
DDR3_DQ15	IO	DDRSS Data	C20	
DDR3_DQ16	IO	DDRSS Data	B28	
DDR3_DQ17	IO	DDRSS Data	B27	
DDR3_DQ18	IO	DDRSS Data	C26	
DDR3_DQ19	IO	DDRSS Data	D26	
DDR3_DQ20	IO	DDRSS Data	F26	
DDR3_DQ21	IO	DDRSS Data	G26	
DDR3_DQ22	IO	DDRSS Data	E27	
DDR3_DQ23	IO	DDRSS Data	D27	
DDR3_DQ24	IO	DDRSS Data	F29	
DDR3_DQ25	IO	DDRSS Data	G29	
DDR3_DQ26	IO	DDRSS Data	F28	
DDR3_DQ27	IO	DDRSS Data	E28	
DDR3_DQ28	IO	DDRSS Data	D29	
DDR3_DQ29	IO	DDRSS Data	C29	
DDR3_DQ30	IO	DDRSS Data	B30	
DDR3_DQ31	IO	DDRSS Data	D30	

Table 5-8. DDRSS3 Signal Descriptions (continued)

SIGNAL NAME [1] ⁽³⁾ ⁽²⁾	PIN TYPE [2]	DESCRIPTION [3]	ALY PIN [4]	AND PIN [4]
DDR3_DQS0N	IO	DDRSS Complimentary Data Strobe	A19	
DDR3_DQS0P	IO	DDRSS Data Strobe	A18	
DDR3_DQS1N	IO	DDRSS Complimentary Data Strobe	A22	
DDR3_DQS1P	IO	DDRSS Data Strobe	A21	
DDR3_DQS2N	IO	DDRSS Complimentary Data Strobe	A27	
DDR3_DQS2P	IO	DDRSS Data Strobe	A26	
DDR3_DQS3N	IO	DDRSS Complimentary Data Strobe	A30	
DDR3_DQS3P	IO	DDRSS Data Strobe	A29	

- (1) An external 240 Ω \pm 1% resistor must be connected between this pin and VSS. No external voltage should be applied to this pin.
- (2) DDRSS0, DDRSS1, DDRSS2, and DDRSS3 must always be used in incremental order. For instance, when using a single LPDDR component, it must be connected to the DDR0_* interface. When using two LPDDR components, they must be connected to DDR0_* and DDR1_* interfaces, and so forth.
- (3) DDRSS2, DDRSS3, and SERDES2 are not available on the 27mm package variant of this SoC. DDRSS2/DDRSS3/SERDES2 should be avoided if software compatibility is desired with systems that use the 27mm package.

5.3.3 GPIO

5.3.3.1 MAIN Domain

Table 5-9. GPIO0 Signal Descriptions

SIGNAL NAME [1]	PIN TYPE [2]	DESCRIPTION [3]	ALY PIN [4]	AND PIN [4]
GPIO0_0	IO	General Purpose Input/Output	AN35	Y29
GPIO0_1	IO	General Purpose Input/Output	AG36	P29
GPIO0_2	IO	General Purpose Input/Output	AJ33	T29
GPIO0_3	IO	General Purpose Input/Output	AF33	T31
GPIO0_4	IO	General Purpose Input/Output	AH33	T32
GPIO0_5	IO	General Purpose Input/Output	AG33	R33
GPIO0_6	IO	General Purpose Input/Output	AK36	R30
GPIO0_7	IO	General Purpose Input/Output	AG34	R29
GPIO0_8	IO	General Purpose Input/Output	AJ35	R31
GPIO0_9	IO	General Purpose Input/Output	AH34	G30
GPIO0_10	IO	General Purpose Input/Output	AE33	U30
GPIO0_11	IO	General Purpose Input/Output	AL32	P32
GPIO0_12	IO	General Purpose Input/Output	AK37	E33
GPIO0_13	IO	General Purpose Input/Output	AJ34	T30
GPIO0_14	IO	General Purpose Input/Output	AK35	J30
GPIO0_15	IO	General Purpose Input/Output	AK38	K31
GPIO0_16	IO	General Purpose Input/Output	AF37	F32
GPIO0_17	IO	General Purpose Input/Output	AG37	H32
GPIO0_18	IO	General Purpose Input/Output	AK33	H33
GPIO0_19	IO	General Purpose Input/Output	AC32	G31
GPIO0_20	IO	General Purpose Input/Output	AC37	J31
GPIO0_21	IO	General Purpose Input/Output	AD37	P33
GPIO0_22	IO	General Purpose Input/Output	AE37	G32
GPIO0_23	IO	General Purpose Input/Output	AC36	K32
GPIO0_24	IO	General Purpose Input/Output	AE36	R32
GPIO0_25	IO	General Purpose Input/Output	AF38	N33
GPIO0_26	IO	General Purpose Input/Output	AE38	G29
GPIO0_27	IO	General Purpose Input/Output	AJ37	G33

Table 5-9. GPIO0 Signal Descriptions (continued)

SIGNAL NAME [1]	PIN TYPE [2]	DESCRIPTION [3]	ALY PIN [4]	AND PIN [4]
GPIO0_28	IO	General Purpose Input/Output	AH38	H31
GPIO0_29	IO	General Purpose Input/Output	AC33	G28
GPIO0_30	IO	General Purpose Input/Output	AH37	F33
GPIO0_31	IO	General Purpose Input/Output	AJ38	F31
GPIO0_32	IO	General Purpose Input/Output	AK34	J32
GPIO0_33	IO	General Purpose Input/Output	AG38	H30
GPIO0_34	IO	General Purpose Input/Output	AF36	K33
GPIO0_35	IO	General Purpose Input/Output	AE35	M31
GPIO0_36	IO	General Purpose Input/Output	AC35	N30
GPIO0_37	IO	General Purpose Input/Output	AG35	T33
GPIO0_38	IO	General Purpose Input/Output	AH36	L32
GPIO0_39	IO	General Purpose Input/Output	AF35	P30
GPIO0_40	IO	General Purpose Input/Output	AD34	M32
GPIO0_41	IO	General Purpose Input/Output	AJ36	L33
GPIO0_42	IO	General Purpose Input/Output	AF34	U31
GPIO0_43	IO	General Purpose Input/Output	AE34	M33
GPIO0_44	IO	General Purpose Input/Output	AL33	P31
GPIO0_45	IO	General Purpose Input/Output	AL34	N31
GPIO0_46	IO	General Purpose Input/Output	AC34	U32
GPIO0_47	IO	General Purpose Input/Output	AD33	N32
GPIO0_48	IO	General Purpose Input/Output	AD38	H29
GPIO0_49	IO	General Purpose Input/Output	AD36	L31
GPIO0_50	IO	General Purpose Input/Output	AJ32	J33
GPIO0_51	IO	General Purpose Input/Output	AM37	Y33
GPIO0_52	IO	General Purpose Input/Output	AP38	Y32
GPIO0_53	IO	General Purpose Input/Output	AN38	V31
GPIO0_54	IO	General Purpose Input/Output	AM35	V30
GPIO0_55	IO	General Purpose Input/Output	AM36	W31
GPIO0_56	IO	General Purpose Input/Output	AN36	AA30
GPIO0_57	IO	General Purpose Input/Output	AP37	Y30
GPIO0_58	IO	General Purpose Input/Output	AR38	AA32
GPIO0_59	IO	General Purpose Input/Output	AN37	W30
GPIO0_60	IO	General Purpose Input/Output	AC38	F30
GPIO0_61	IO	General Purpose Input/Output	AA32	E30
GPIO0_62	IO	General Purpose Input/Output	AB34	F29
GPIO0_63	IO	General Purpose Input/Output	AA33	F28
GPIO0_64	IO	General Purpose Input/Output	AB38	D33
GPIO0_65	IO	General Purpose Input/Output	AB36	E32

5.3.3.2 WKUP Domain

Table 5-10. WKUP_GPIO0 Signal Descriptions

SIGNAL NAME [1]	PIN TYPE [2]	DESCRIPTION [3]	ALY PIN [4]	AND PIN [4]
WKUP_GPIO0_0	IO	General Purpose Input/Output	H38	E15
WKUP_GPIO0_1	IO	General Purpose Input/Output	J34	D16
WKUP_GPIO0_2	IO	General Purpose Input/Output	J35	D18

Table 5-10. WKUP_GPIO0 Signal Descriptions (continued)

SIGNAL NAME [1]	PIN TYPE [2]	DESCRIPTION [3]	ALY PIN [4]	AND PIN [4]
WKUP_GPIO0_3	IO	General Purpose Input/Output	J36	D19
WKUP_GPIO0_4	IO	General Purpose Input/Output	H35	E16
WKUP_GPIO0_5	IO	General Purpose Input/Output	K36	D20
WKUP_GPIO0_6	IO	General Purpose Input/Output	L37	B15
WKUP_GPIO0_7	IO	General Purpose Input/Output	L36	B17
WKUP_GPIO0_8	IO	General Purpose Input/Output	L35	B19
WKUP_GPIO0_9	IO	General Purpose Input/Output	L34	A15
WKUP_GPIO0_10	IO	General Purpose Input/Output	L33	B18
WKUP_GPIO0_11	IO	General Purpose Input/Output	M38	B21
WKUP_GPIO0_12	IO	General Purpose Input/Output	J37	D17
WKUP_GPIO0_13	IO	General Purpose Input/Output	K38	D21
WKUP_GPIO0_14	IO	General Purpose Input/Output	H37	D15
WKUP_GPIO0_15	IO	General Purpose Input/Output	K37	C16
WKUP_GPIO0_16	IO	General Purpose Input/Output	E32	D8
WKUP_GPIO0_17	IO	General Purpose Input/Output	D32	D10
WKUP_GPIO0_18	IO	General Purpose Input/Output	C34	C10
WKUP_GPIO0_19	IO	General Purpose Input/Output	B33	E10
WKUP_GPIO0_20	IO	General Purpose Input/Output	B32	F9
WKUP_GPIO0_21	IO	General Purpose Input/Output	C33	E9
WKUP_GPIO0_22	IO	General Purpose Input/Output	C35	D11
WKUP_GPIO0_23	IO	General Purpose Input/Output	D33	D9
WKUP_GPIO0_24	IO	General Purpose Input/Output	D34	C9
WKUP_GPIO0_25	IO	General Purpose Input/Output	E34	C7
WKUP_GPIO0_26	IO	General Purpose Input/Output	E33	C8
WKUP_GPIO0_27	IO	General Purpose Input/Output	A32	F12
WKUP_GPIO0_28	IO	General Purpose Input/Output	A33	F11
WKUP_GPIO0_29	IO	General Purpose Input/Output	B34	F10
WKUP_GPIO0_30	IO	General Purpose Input/Output	C32	E11
WKUP_GPIO0_31	IO	General Purpose Input/Output	F32	B7
WKUP_GPIO0_32	IO	General Purpose Input/Output	C31	B10
WKUP_GPIO0_33	IO	General Purpose Input/Output	F31	B9
WKUP_GPIO0_34	IO	General Purpose Input/Output	E35	B8
WKUP_GPIO0_35	IO	General Purpose Input/Output	D31	B11
WKUP_GPIO0_36	IO	General Purpose Input/Output	G31	A11
WKUP_GPIO0_37	IO	General Purpose Input/Output	F33	A10
WKUP_GPIO0_38	IO	General Purpose Input/Output	G32	A8
WKUP_GPIO0_39	IO	General Purpose Input/Output	G33	A9
WKUP_GPIO0_40	IO	General Purpose Input/Output	C38	B14
WKUP_GPIO0_41	IO	General Purpose Input/Output	C37	C12
WKUP_GPIO0_42	IO	General Purpose Input/Output	E38	A12
WKUP_GPIO0_43	IO	General Purpose Input/Output	E37	B12
WKUP_GPIO0_44	IO	General Purpose Input/Output	D38	A13
WKUP_GPIO0_45	IO	General Purpose Input/Output	D37	B13
WKUP_GPIO0_46	IO	General Purpose Input/Output	E36	A14
WKUP_GPIO0_47	IO	General Purpose Input/Output	B37	C14

Table 5-10. WKUP_GPIO0 Signal Descriptions (continued)

SIGNAL NAME [1]	PIN TYPE [2]	DESCRIPTION [3]	ALY PIN [4]	AND PIN [4]
WKUP_GPIO0_48	IO	General Purpose Input/Output	D36	D13
WKUP_GPIO0_49	IO	General Purpose Input/Output	M33	A20
WKUP_GPIO0_50	IO	General Purpose Input/Output	B36	D14
WKUP_GPIO0_51	IO	General Purpose Input/Output	A35	E13
WKUP_GPIO0_52	IO	General Purpose Input/Output	B35	F13
WKUP_GPIO0_53	IO	General Purpose Input/Output	A36	E12
WKUP_GPIO0_54	IO	General Purpose Input/Output	G38	F15
WKUP_GPIO0_55	IO	General Purpose Input/Output	H36	E18
WKUP_GPIO0_56	IO	General Purpose Input/Output	M37	A19
WKUP_GPIO0_57	IO	General Purpose Input/Output	M36	B20
WKUP_GPIO0_58	IO	General Purpose Input/Output	K35	C20
WKUP_GPIO0_59	IO	General Purpose Input/Output	K34	C19
WKUP_GPIO0_60	IO	General Purpose Input/Output	K33	E22
WKUP_GPIO0_61	IO	General Purpose Input/Output	F38	C18
WKUP_GPIO0_62	IO	General Purpose Input/Output	C36	D12
WKUP_GPIO0_63	IO	General Purpose Input/Output	N33	A16
WKUP_GPIO0_64	IO	General Purpose Input/Output	N35	D23
WKUP_GPIO0_65	IO	General Purpose Input/Output	M35	D22
WKUP_GPIO0_66	IO	General Purpose Input/Output	N34	A17
WKUP_GPIO0_67	IO	General Purpose Input/Output	M34	A18
WKUP_GPIO0_68	IO	General Purpose Input/Output	F36	E21
WKUP_GPIO0_69	IO	General Purpose Input/Output	J38	E14
WKUP_GPIO0_70	IO	General Purpose Input/Output	F37	E19
WKUP_GPIO0_71	I	General Purpose Input/Output	P36	E26
WKUP_GPIO0_72	I	General Purpose Input/Output	V36	F25
WKUP_GPIO0_73	I	General Purpose Input/Output	T34	F23
WKUP_GPIO0_74	I	General Purpose Input/Output	T36	A28
WKUP_GPIO0_75	I	General Purpose Input/Output	P34	E24
WKUP_GPIO0_76	I	General Purpose Input/Output	R37	D27
WKUP_GPIO0_77	I	General Purpose Input/Output	R33	A26
WKUP_GPIO0_78	I	General Purpose Input/Output	V38	B27
WKUP_GPIO0_79	I	General Purpose Input/Output	Y38	C32
WKUP_GPIO0_80	I	General Purpose Input/Output	Y34	B33
WKUP_GPIO0_81	I	General Purpose Input/Output	V34	B31
WKUP_GPIO0_82	I	General Purpose Input/Output	W37	B29
WKUP_GPIO0_83	I	General Purpose Input/Output	AA37	D31
WKUP_GPIO0_84	I	General Purpose Input/Output	W33	A32
WKUP_GPIO0_85	I	General Purpose Input/Output	U33	A30
WKUP_GPIO0_86	I	General Purpose Input/Output	Y36	C28
WKUP_GPIO0_87	IO	General Purpose Input/Output	G34	A21
WKUP_GPIO0_88	IO	General Purpose Input/Output	L38	B16

5.3.4 I2C

5.3.4.1 MAIN Domain

Table 5-11. I2C0 Signal Descriptions

SIGNAL NAME [1]	PIN TYPE [2]	DESCRIPTION [3]	ALY PIN [4]	AND PIN [4]
I2C0_SCL	IOD	I2C Clock	AN36	AA30
I2C0_SDA	IOD	I2C Data	AP37	Y30

Table 5-12. I2C1 Signal Descriptions

SIGNAL NAME [1]	PIN TYPE [2]	DESCRIPTION [3]	ALY PIN [4]	AND PIN [4]
I2C1_SCL	IOD	I2C Clock	AD36, AE34, AJ35	L31, M33, R31
I2C1_SDA	IOD	I2C Data	AH34, AJ32, AL33	G30, J33, P31

Table 5-13. I2C2 Signal Descriptions

SIGNAL NAME [1]	PIN TYPE [2]	DESCRIPTION [3]	ALY PIN [4]	AND PIN [4]
I2C2_SCL	IOD	I2C Clock	AC32, AN38	G31, V31
I2C2_SDA	IOD	I2C Data	AC37, AM35	J31, V30

Table 5-14. I2C3 Signal Descriptions

SIGNAL NAME [1]	PIN TYPE [2]	DESCRIPTION [3]	ALY PIN [4]	AND PIN [4]
I2C3_SCL	IOD	I2C Clock	AC38, AF38	F30, N33
I2C3_SDA	IOD	I2C Data	AA32, AE36	E30, R32

Table 5-15. I2C4 Signal Descriptions

SIGNAL NAME [1]	PIN TYPE [2]	DESCRIPTION [3]	ALY PIN [4]	AND PIN [4]
I2C4_SCL	IOD	I2C Clock	AA33, AG33, AG38	F28, H30, R33
I2C4_SDA	IOD	I2C Data	AB34, AH33, AK34	F29, J32, T32

Table 5-16. I2C5 Signal Descriptions

SIGNAL NAME [1]	PIN TYPE [2]	DESCRIPTION [3]	ALY PIN [4]	AND PIN [4]
I2C5_SCL	IOD	I2C Clock	AC33, AG34	G28, R29
I2C5_SDA	IOD	I2C Data	AH37, AK36	F33, R30

Table 5-17. I2C6 Signal Descriptions

SIGNAL NAME [1]	PIN TYPE [2]	DESCRIPTION [3]	ALY PIN [4]	AND PIN [4]
I2C6_SCL	IOD	I2C Clock	AB36, AN37	E32, W30
I2C6_SDA	IOD	I2C Data	AB38, AR38	AA32, D33

5.3.4.2 MCU Domain

Table 5-18. MCU_I2C0 Signal Descriptions

SIGNAL NAME [1]	PIN TYPE [2]	DESCRIPTION [3]	ALY PIN [4]	AND PIN [4]
MCU_I2C0_SCL	IOD	I2C Clock	M35	D22
MCU_I2C0_SDA	IOD	I2C Data	G34	A21

Table 5-19. MCU_I2C1 Signal Descriptions

SIGNAL NAME [1]	PIN TYPE [2]	DESCRIPTION [3]	ALY PIN [4]	AND PIN [4]
MCU_I2C1_SCL	IOD	I2C Clock	L35, L37	B15, B19

Table 5-19. MCU_I2C1 Signal Descriptions (continued)

SIGNAL NAME [1]	PIN TYPE [2]	DESCRIPTION [3]	ALY PIN [4]	AND PIN [4]
MCU_I2C1_SDA	IOD	I2C Data	L34, L36	A15, B17

5.3.4.3 WKUP Domain

Table 5-20. WKUP_I2C0 Signal Descriptions

SIGNAL NAME [1]	PIN TYPE [2]	DESCRIPTION [3]	ALY PIN [4]	AND PIN [4]
WKUP_I2C0_SCL	IOD	I2C Clock	N33	A16
WKUP_I2C0_SDA	IOD	I2C Data	N35	D23

5.3.5 I3C

5.3.5.1 MCU Domain

Table 5-21. MCU_I3C0 Signal Descriptions

SIGNAL NAME [1]	PIN TYPE [2]	DESCRIPTION [3]	ALY PIN [4]	AND PIN [4]
MCU_I3C0_SCL	IO	I3C Clock	L35	B19
MCU_I3C0_SDA	IO	I3C Data	L34	A15
MCU_I3C0_SDAPULLEN	OD	I3C Data Pull Enable	L38, M38	B16, B21

5.3.6 MCAN

5.3.6.1 MAIN Domain

Table 5-22. MCAN0 Signal Descriptions

SIGNAL NAME [1]	PIN TYPE [2]	DESCRIPTION [3]	ALY PIN [4]	AND PIN [4]
MCAN0_RX	I	MCAN Receive Data	AE38	G29
MCAN0_TX	O	MCAN Transmit Data	AF38	N33

Table 5-23. MCAN1 Signal Descriptions

SIGNAL NAME [1]	PIN TYPE [2]	DESCRIPTION [3]	ALY PIN [4]	AND PIN [4]
MCAN1_RX	I	MCAN Receive Data	AH38, AJ32	H31, J33
MCAN1_TX	O	MCAN Transmit Data	AJ37	G33

Table 5-24. MCAN2 Signal Descriptions

SIGNAL NAME [1]	PIN TYPE [2]	DESCRIPTION [3]	ALY PIN [4]	AND PIN [4]
MCAN2_RX	I	MCAN Receive Data	AH37	F33
MCAN2_TX	O	MCAN Transmit Data	AC33	G28

Table 5-25. MCAN3 Signal Descriptions

SIGNAL NAME [1]	PIN TYPE [2]	DESCRIPTION [3]	ALY PIN [4]	AND PIN [4]
MCAN3_RX	I	MCAN Receive Data	AK34	J32
MCAN3_TX	O	MCAN Transmit Data	AJ38	F31

Table 5-26. MCAN4 Signal Descriptions

SIGNAL NAME [1]	PIN TYPE [2]	DESCRIPTION [3]	ALY PIN [4]	AND PIN [4]
MCAN4_RX	I	MCAN Receive Data	AF36	K33
MCAN4_TX	O	MCAN Transmit Data	AG38	H30

Table 5-27. MCAN5 Signal Descriptions

SIGNAL NAME [1]	PIN TYPE [2]	DESCRIPTION [3]	ALY PIN [4]	AND PIN [4]
MCAN5_RX	I	MCAN Receive Data	AC35, AK38	K31, N30
MCAN5_TX	O	MCAN Transmit Data	AE35, AK35	J30, M31

Table 5-28. MCAN6 Signal Descriptions

SIGNAL NAME [1]	PIN TYPE [2]	DESCRIPTION [3]	ALY PIN [4]	AND PIN [4]
MCAN6_RX	I	MCAN Receive Data	AG37, AH36	H32, L32
MCAN6_TX	O	MCAN Transmit Data	AF37, AG35	F32, T33

Table 5-29. MCAN7 Signal Descriptions

SIGNAL NAME [1]	PIN TYPE [2]	DESCRIPTION [3]	ALY PIN [4]	AND PIN [4]
MCAN7_RX	I	MCAN Receive Data	AC32, AD34	G31, M32
MCAN7_TX	O	MCAN Transmit Data	AF35, AK33	H33, P30

Table 5-30. MCAN8 Signal Descriptions

SIGNAL NAME [1]	PIN TYPE [2]	DESCRIPTION [3]	ALY PIN [4]	AND PIN [4]
MCAN8_RX	I	MCAN Receive Data	AD37, AF34	P33, U31
MCAN8_TX	O	MCAN Transmit Data	AC37, AJ36	J31, L33

Table 5-31. MCAN9 Signal Descriptions

SIGNAL NAME [1]	PIN TYPE [2]	DESCRIPTION [3]	ALY PIN [4]	AND PIN [4]
MCAN9_RX	I	MCAN Receive Data	AC36, AL33	K32, P31
MCAN9_TX	O	MCAN Transmit Data	AE34, AE37	G32, M33

Table 5-32. MCAN10 Signal Descriptions

SIGNAL NAME [1]	PIN TYPE [2]	DESCRIPTION [3]	ALY PIN [4]	AND PIN [4]
MCAN10_RX	I	MCAN Receive Data	AC34	U32
MCAN10_TX	O	MCAN Transmit Data	AL34	N31

Table 5-33. MCAN11 Signal Descriptions

SIGNAL NAME [1]	PIN TYPE [2]	DESCRIPTION [3]	ALY PIN [4]	AND PIN [4]
MCAN11_RX	I	MCAN Receive Data	AD38	H29
MCAN11_TX	O	MCAN Transmit Data	AD33	N32

Table 5-34. MCAN12 Signal Descriptions

SIGNAL NAME [1]	PIN TYPE [2]	DESCRIPTION [3]	ALY PIN [4]	AND PIN [4]
MCAN12_RX	I	MCAN Receive Data	AJ33, AK37	E33, T29
MCAN12_TX	O	MCAN Transmit Data	AD36, AG36	L31, P29

Table 5-35. MCAN13 Signal Descriptions

SIGNAL NAME [1]	PIN TYPE [2]	DESCRIPTION [3]	ALY PIN [4]	AND PIN [4]
MCAN13_RX	I	MCAN Receive Data	AH33, AN37	T32, W30
MCAN13_TX	O	MCAN Transmit Data	AF33, AR38	AA32, T31

Table 5-36. MCAN14 Signal Descriptions

SIGNAL NAME [1]	PIN TYPE [2]	DESCRIPTION [3]	ALY PIN [4]	AND PIN [4]
MCAN14_RX	I	MCAN Receive Data	AK36, AP38	R30, Y32

Table 5-36. MCAN14 Signal Descriptions (continued)

SIGNAL NAME [1]	PIN TYPE [2]	DESCRIPTION [3]	ALY PIN [4]	AND PIN [4]
MCAN14_TX	O	MCAN Transmit Data	AG33, AM37	R33, Y33

Table 5-37. MCAN15 Signal Descriptions

SIGNAL NAME [1]	PIN TYPE [2]	DESCRIPTION [3]	ALY PIN [4]	AND PIN [4]
MCAN15_RX	I	MCAN Receive Data	AB36, AJ35	E32, R31
MCAN15_TX	O	MCAN Transmit Data	AB38, AG34	D33, R29

Table 5-38. MCAN16 Signal Descriptions

SIGNAL NAME [1]	PIN TYPE [2]	DESCRIPTION [3]	ALY PIN [4]	AND PIN [4]
MCAN16_RX	I	MCAN Receive Data	AE33	U30
MCAN16_TX	O	MCAN Transmit Data	AH34	G30

Table 5-39. MCAN17 Signal Descriptions

SIGNAL NAME [1]	PIN TYPE [2]	DESCRIPTION [3]	ALY PIN [4]	AND PIN [4]
MCAN17_RX	I	MCAN Receive Data	AE36, AJ34	R32, T30
MCAN17_TX	O	MCAN Transmit Data	AL32	P32

5.3.6.2 MCU Domain

Table 5-40. MCU_MCAN0 Signal Descriptions

SIGNAL NAME [1]	PIN TYPE [2]	DESCRIPTION [3]	ALY PIN [4]	AND PIN [4]
MCU_MCAN0_RX	I	MCAN Receive Data	F38	C18
MCU_MCAN0_TX	O	MCAN Transmit Data	K33	E22

Table 5-41. MCU_MCAN1 Signal Descriptions

SIGNAL NAME [1]	PIN TYPE [2]	DESCRIPTION [3]	ALY PIN [4]	AND PIN [4]
MCU_MCAN1_RX	I	MCAN Receive Data	K36	D20
MCU_MCAN1_TX	O	MCAN Transmit Data	H35	E16

5.3.7 MCSPI

5.3.7.1 MAIN Domain

Table 5-42. MCSPI0 Signal Descriptions

SIGNAL NAME [1]	PIN TYPE [2]	DESCRIPTION [3]	ALY PIN [4]	AND PIN [4]
SPI0_CLK	IO	SPI Clock	AN38	V31
SPI0_CS0	IO	SPI Chip Select 0	AM37	Y33
SPI0_CS1	IO	SPI Chip Select 1	AP38	Y32
SPI0_CS2	IO	SPI Chip Select 2	AJ35	R31
SPI0_CS3	IO	SPI Chip Select 3	AE33	U30
SPI0_D0	IO	SPI Data 0	AM35	V30
SPI0_D1	IO	SPI Data 1	AM36	W31

Table 5-43. MCSPI1 Signal Descriptions

SIGNAL NAME [1]	PIN TYPE [2]	DESCRIPTION [3]	ALY PIN [4]	AND PIN [4]
SPI1_CLK	IO	SPI Clock	AB38	D33
SPI1_CS0	IO	SPI Chip Select 0	AC38	F30
SPI1_CS1	IO	SPI Chip Select 1	AA32	E30

Table 5-43. MCSPI1 Signal Descriptions (continued)

SIGNAL NAME [1]	PIN TYPE [2]	DESCRIPTION [3]	ALY PIN [4]	AND PIN [4]
SPI1_CS2	IO	SPI Chip Select 2	AB34	F29
SPI1_CS3	IO	SPI Chip Select 3	AH34	G30
SPI1_D0	IO	SPI Data 0	AA33	F28
SPI1_D1	IO	SPI Data 1	AB36	E32

Table 5-44. MCSPI2 Signal Descriptions

SIGNAL NAME [1]	PIN TYPE [2]	DESCRIPTION [3]	ALY PIN [4]	AND PIN [4]
SPI2_CLK	IO	SPI Clock	AD34	M32
SPI2_CS0	IO	SPI Chip Select 0	AJ36	L33
SPI2_CS1	IO	SPI Chip Select 1	AF35	P30
SPI2_CS2	IO	SPI Chip Select 2	AF37	F32
SPI2_CS3	IO	SPI Chip Select 3	AG37	H32
SPI2_D0	IO	SPI Data 0	AF34	U31
SPI2_D1	IO	SPI Data 1	AE34	M33

Table 5-45. MCSPI3 Signal Descriptions

SIGNAL NAME [1]	PIN TYPE [2]	DESCRIPTION [3]	ALY PIN [4]	AND PIN [4]
SPI3_CLK	IO	SPI Clock	AD38	H29
SPI3_CS0	IO	SPI Chip Select 0	AD33	N32
SPI3_CS1	IO	SPI Chip Select 1	AJ38	F31
SPI3_CS2	IO	SPI Chip Select 2	AF36	K33
SPI3_CS3	IO	SPI Chip Select 3	AC34	U32
SPI3_D0	IO	SPI Data 0	AC32	G31
SPI3_D1	IO	SPI Data 1	AC37	J31

Table 5-46. MCSPI5 Signal Descriptions

SIGNAL NAME [1]	PIN TYPE [2]	DESCRIPTION [3]	ALY PIN [4]	AND PIN [4]
SPI5_CLK	IO	SPI Clock	AJ38	F31
SPI5_CS0	IO	SPI Chip Select 0	AE38	G29
SPI5_CS1	IO	SPI Chip Select 1	AF38	N33
SPI5_CS2	IO	SPI Chip Select 2	AD37	P33
SPI5_CS3	IO	SPI Chip Select 3	AE37	G32
SPI5_D0	IO	SPI Data 0	AH38	H31
SPI5_D1	IO	SPI Data 1	AF36	K33

Table 5-47. MCSPI6 Signal Descriptions

SIGNAL NAME [1]	PIN TYPE [2]	DESCRIPTION [3]	ALY PIN [4]	AND PIN [4]
SPI6_CLK	IO	SPI Clock	AK37	E33
SPI6_CS0	IO	SPI Chip Select 0	AJ34	T30
SPI6_CS1	IO	SPI Chip Select 1	AH37	F33
SPI6_CS2	IO	SPI Chip Select 2	AK34	J32
SPI6_CS3	IO	SPI Chip Select 3	AG38	H30
SPI6_D0	IO	SPI Data 0	AD36	L31
SPI6_D1	IO	SPI Data 1	AC33	G28

Table 5-48. MCSPI7 Signal Descriptions

SIGNAL NAME [1]	PIN TYPE [2]	DESCRIPTION [3]	ALY PIN [4]	AND PIN [4]
SPI7_CLK	IO	SPI Clock	AF37	F32
SPI7_CS0	IO	SPI Chip Select 0	AG37	H32
SPI7_CS1	IO	SPI Chip Select 1	AD37	P33
SPI7_CS2	IO	SPI Chip Select 2	AE37	G32
SPI7_CS3	IO	SPI Chip Select 3	AL32	P32
SPI7_D0	IO	SPI Data 0	AE38	G29
SPI7_D1	IO	SPI Data 1	AJ38	F31

5.3.7.2 MCU Domain

Table 5-49. MCU_MCSPI0 Signal Descriptions

SIGNAL NAME [1]	PIN TYPE [2]	DESCRIPTION [3]	ALY PIN [4]	AND PIN [4]
MCU_SPIO_CLK	IO	SPI Clock	G38	F15
MCU_SPIO_CS0	IO	SPI Chip Select 0	F37	E19
MCU_SPIO_CS1	IO	SPI Chip Select 1	F33, J37	A10, D17
MCU_SPIO_CS2	IO	SPI Chip Select 2	G33, H37	A9, D15
MCU_SPIO_CS3	IO	SPI Chip Select 3	H35	E16
MCU_SPIO_D0	IO	SPI Data 0	H36	E18
MCU_SPIO_D1	IO	SPI Data 1	J38	E14

Table 5-50. MCU_MCSPI1 Signal Descriptions

SIGNAL NAME [1]	PIN TYPE [2]	DESCRIPTION [3]	ALY PIN [4]	AND PIN [4]
MCU_SPI1_CLK	IO	SPI Clock	H38	E15
MCU_SPI1_CS0	IO	SPI Chip Select 0	J36	D19
MCU_SPI1_CS1	IO	SPI Chip Select 1	D31, K38	B11, D21
MCU_SPI1_CS2	IO	SPI Chip Select 2	G31, K37	A11, C16
MCU_SPI1_CS3	IO	SPI Chip Select 3	K36	D20
MCU_SPI1_D0	IO	SPI Data 0	J34	D16
MCU_SPI1_D1	IO	SPI Data 1	J35	D18

5.3.8 UART

5.3.8.1 MAIN Domain

Table 5-51. UART0 Signal Descriptions

SIGNAL NAME [1]	PIN TYPE [2]	DESCRIPTION [3]	ALY PIN [4]	AND PIN [4]
UART0_CTSn	I	UART Clear to Send (active low)	AC32, AC38	F30, G31
UART0_DCDn	I	UART Data Carrier Detect (active low)	AJ33	T29
UART0_DSRn	I	UART Data Set Ready (active low)	AF33	T31
UART0_DTRn	O	UART Data Terminal Ready (active low)	AH33	T32
UART0_RIn	I	UART Ring Indicator	AG33	R33
UART0_RTSn	O	UART Request to Send (active low)	AB38, AC37, AP38	D33, J31, Y32
UART0_RXD	I	UART Receive Data	AD33	N32
UART0_TXD	O	UART Transmit Data	AD38	H29

Table 5-52. UART1 Signal Descriptions

SIGNAL NAME [1]	PIN TYPE [2]	DESCRIPTION [3]	ALY PIN [4]	AND PIN [4]
UART1_CTSn	I	UART Clear to Send (active low)	AC36, AN38	K32, V31

Table 5-52. UART1 Signal Descriptions (continued)

SIGNAL NAME [1]	PIN TYPE [2]	DESCRIPTION [3]	ALY PIN [4]	AND PIN [4]
UART1_RTSn	O	UART Request to Send (active low)	AE36, AM35	R32, V30
UART1_RXD	I	UART Receive Data	AD37	P33
UART1_TXD	O	UART Transmit Data	AE37	G32

Table 5-53. UART2 Signal Descriptions

SIGNAL NAME [1]	PIN TYPE [2]	DESCRIPTION [3]	ALY PIN [4]	AND PIN [4]
UART2_CTSn	I	UART Clear to Send (active low)	AD36	L31
UART2_RTSn	O	UART Request to Send (active low)	AJ32	J33
UART2_RXD	I	UART Receive Data	AB34, AF38, AM35	F29, N33, V30
UART2_TXD	O	UART Transmit Data	AA33, AE38, AM36	F28, G29, W31

Table 5-54. UART3 Signal Descriptions

SIGNAL NAME [1]	PIN TYPE [2]	DESCRIPTION [3]	ALY PIN [4]	AND PIN [4]
UART3_CTSn	I	UART Clear to Send (active low)	AJ38	F31
UART3_RTSn	O	UART Request to Send (active low)	AH38	H31
UART3_RXD	I	UART Receive Data	AC33, AD36, AR38	AA32, G28, L31
UART3_TXD	O	UART Transmit Data	AH37, AJ32, AN37	F33, J33, W30

Table 5-55. UART4 Signal Descriptions

SIGNAL NAME [1]	PIN TYPE [2]	DESCRIPTION [3]	ALY PIN [4]	AND PIN [4]
UART4_CTSn	I	UART Clear to Send (active low)	AB38, AG35, AK33	D33, H33, T33
UART4_RTSn	O	UART Request to Send (active low)	AB36, AC34, AH36	E32, L32, U32
UART4_RXD	I	UART Receive Data	AB34, AE35, AF37, AL34	F29, F32, M31, N31
UART4_TXD	O	UART Transmit Data	AA33, AC35, AF33, AG37	F28, H32, N30, T31

Table 5-56. UART5 Signal Descriptions

SIGNAL NAME [1]	PIN TYPE [2]	DESCRIPTION [3]	ALY PIN [4]	AND PIN [4]
UART5_CTSn	I	UART Clear to Send (active low)	AB34, AJ36	F29, L33
UART5_RTSn	O	UART Request to Send (active low)	AA33, AF34	F28, U31
UART5_RXD	I	UART Receive Data	AC38, AF35, AJ33	F30, P30, T29
UART5_TXD	O	UART Transmit Data	AA32, AD34, AG36	E30, M32, P29

Table 5-57. UART6 Signal Descriptions

SIGNAL NAME [1]	PIN TYPE [2]	DESCRIPTION [3]	ALY PIN [4]	AND PIN [4]
UART6_CTSn	I	UART Clear to Send (active low)	AF38	N33
UART6_RTSn	O	UART Request to Send (active low)	AE38	G29
UART6_RXD	I	UART Receive Data	AC36, AG33, AK37	E33, K32, R33
UART6_TXD	O	UART Transmit Data	AE36, AH33, AJ37	G33, R32, T32

Table 5-58. UART7 Signal Descriptions

SIGNAL NAME [1]	PIN TYPE [2]	DESCRIPTION [3]	ALY PIN [4]	AND PIN [4]
UART7_CTSn	I	UART Clear to Send (active low)	AB34	F29
UART7_RTSn	O	UART Request to Send (active low)	AA33	F28
UART7_RXD	I	UART Receive Data	AC38, AJ36, AL32	F30, L33, P32

Table 5-58. UART7 Signal Descriptions (continued)

SIGNAL NAME [1]	PIN TYPE [2]	DESCRIPTION [3]	ALY PIN [4]	AND PIN [4]
UART7_TXD	O	UART Transmit Data	AA32, AF34, AJ34	E30, T30, U31

Table 5-59. UART8 Signal Descriptions

SIGNAL NAME [1]	PIN TYPE [2]	DESCRIPTION [3]	ALY PIN [4]	AND PIN [4]
UART8_CTSn	I	UART Clear to Send (active low)	AF37	F32
UART8_RTSn	O	UART Request to Send (active low)	AG37	H32
UART8_RXD	I	UART Receive Data	AB38, AE34, AK35, AP38	D33, J30, M33, Y32
UART8_TXD	O	UART Transmit Data	AB36, AK38, AL33, AN38	E32, K31, P31, V31

Table 5-60. UART9 Signal Descriptions

SIGNAL NAME [1]	PIN TYPE [2]	DESCRIPTION [3]	ALY PIN [4]	AND PIN [4]
UART9_CTSn	I	UART Clear to Send (active low)	AK33, AK37	E33, H33
UART9_RTSn	O	UART Request to Send (active low)	AC34, AJ34	T30, U32
UART9_RXD	I	UART Receive Data	AC32, AG34	G31, R29
UART9_TXD	O	UART Transmit Data	AC37, AK36	J31, R30

5.3.8.2 MCU Domain

Table 5-61. MCU_UART0 Signal Descriptions

SIGNAL NAME [1]	PIN TYPE [2]	DESCRIPTION [3]	ALY PIN [4]	AND PIN [4]
MCU_UART0_CTSn	I	UART Clear to Send (active low)	F33, H37	A10, D15
MCU_UART0_RTSn	O	UART Request to Send (active low)	G33, K37	A9, C16
MCU_UART0_RXD	I	UART Receive Data	D31, K38, M38	B11, B21, D21
MCU_UART0_TXD	O	UART Transmit Data	G31, J37, L33	A11, B18, D17

5.3.8.3 WKUP Domain

Table 5-62. WKUP_UART0 Signal Descriptions

SIGNAL NAME [1]	PIN TYPE [2]	DESCRIPTION [3]	ALY PIN [4]	AND PIN [4]
WKUP_UART0_CTSn	I	UART Clear to Send (active low)	L37	B15
WKUP_UART0_RTSn	O	UART Request to Send (active low)	L36	B17
WKUP_UART0_RXD	I	UART Receive Data	K35	C20
WKUP_UART0_TXD	O	UART Transmit Data	K34	C19

5.3.9 MDIO

5.3.9.1 MAIN Domain

Table 5-63. MDIO0 Signal Descriptions

SIGNAL NAME [1]	PIN TYPE [2]	DESCRIPTION [3]	ALY PIN [4]	AND PIN [4]
MDIO0_MDC	O	MDIO Clock	AD38	H29
MDIO0_MDIO	IO	MDIO Data	AD33	N32

Table 5-64. MDIO1 Signal Descriptions

SIGNAL NAME [1]	PIN TYPE [2]	DESCRIPTION [3]	ALY PIN [4]	AND PIN [4]
MDIO1_MDC	O	MDIO Clock	AE37	G32
MDIO1_MDIO	IO	MDIO Data	AC36	K32

5.3.9.2 MCU Domain

Table 5-65. MCU_MDIO0 Signal Descriptions

SIGNAL NAME [1]	PIN TYPE [2]	DESCRIPTION [3]	ALY PIN [4]	AND PIN [4]
MCU_MDIO0_MDC	O	MDIO Clock	A36	E12
MCU_MDIO0_MDIO	IO	MDIO Data	B35	F13

5.3.10 UFS

5.3.10.1 MAIN Domain

Table 5-66. UFS0 Signal Descriptions

SIGNAL NAME [1]	PIN TYPE [2]	DESCRIPTION [3]	ALY PIN [4]	AND PIN [4]
UFS0_REF_CLK	I	UFS Reference Clock	AM7	AJ5
UFS0_RSTn	I	UFS Reset	AM8	AJ7
UFS0_RX_DN0	I	UFS Receive Data (negative)	AM4	AK5
UFS0_RX_DN1	I	UFS Receive Data (negative)	AM1	AL4
UFS0_RX_DP0	I	UFS Receive Data (positive)	AM5	AK6
UFS0_RX_DP1	I	UFS Receive Data (positive)	AM2	AL5
UFS0_TX_DN0	I	UFS Transmit Data (negative)	AL2	AN2
UFS0_TX_DN1	I	UFS Transmit Data (negative)	AN2	AM3
UFS0_TX_DP0	I	UFS Transmit Data (positive)	AL3	AN3
UFS0_TX_DP1	I	UFS Transmit Data (positive)	AN3	AM4

5.3.11 CPSW2G

5.3.11.1 MAIN Domain

Table 5-67. CPSW2G0 Signal Descriptions

SIGNAL NAME [1]	PIN TYPE [2]	DESCRIPTION [3]	ALY PIN [4]	AND PIN [4]
CLKOUT	IO	RMII Clock Output	AF34	U31
RGMII1_RXC	I	RGMII Receive Clock	AL33	P31
RGMII1_RX_CTL	I	RGMII Receive Control	AE34	M33
RGMII1_TXC	O	RGMII Transmit Clock	AL34	N31
RGMII1_TX_CTL	O	RGMII Transmit Control	AF35	P30
RGMII1_RD0	I	RGMII Receive Data 0	AC34	U32
RGMII1_RD1	I	RGMII Receive Data 1	AD34	M32
RGMII1_RD2	I	RGMII Receive Data 2	AJ36	L33
RGMII1_RD3	I	RGMII Receive Data 3	AF34	U31
RGMII1_TD0	O	RGMII Transmit Data 0	AE35	M31
RGMII1_TD1	O	RGMII Transmit Data 1	AC35	N30
RGMII1_TD2	O	RGMII Transmit Data 2	AG35	T33
RGMII1_TD3	O	RGMII Transmit Data 3	AH36	L32
RMII1_CRSDV	I	RMII Carrier Sense / Data Valid	AH36	L32
RMII1_RX_ER	I	RMII Receive Data Error	AF35	P30
RMII1_TX_EN	O	RMII Transmit Enable	AE34	M33
RMII1_RXD0	I	RMII Receive Data 0	AC35	N30
RMII1_RXD1	I	RMII Receive Data 1	AG35	T33
RMII1_TXD0	O	RMII Transmit Data 0	AD34	M32
RMII1_TXD1	O	RMII Transmit Data 1	AL33	P31
RMII_REF_CLK	I	RMII Reference Clock	AJ36	L33

5.3.11.2 MCU Domain

Table 5-68. MCU_CPSW2G0 Signal Descriptions

SIGNAL NAME [1]	PIN TYPE [2]	DESCRIPTION [3]	ALY PIN [4]	AND PIN [4]
MCU_RGMII1_RXC	I	RGMII Receive Clock	B37	C14
MCU_RGMII1_RX_CTL	I	RGMII Receive Control	C37	C12
MCU_RGMII1_TXC	O	RGMII Transmit Clock	E36	A14
MCU_RGMII1_TX_CTL	O	RGMII Transmit Control	C38	B14
MCU_RGMII1_RD0	I	RGMII Receive Data 0	A35	E13
MCU_RGMII1_RD1	I	RGMII Receive Data 1	B36	D14
MCU_RGMII1_RD2	I	RGMII Receive Data 2	C36	D12
MCU_RGMII1_RD3	I	RGMII Receive Data 3	D36	D13
MCU_RGMII1_TD0	O	RGMII Transmit Data 0	D37	B13
MCU_RGMII1_TD1	O	RGMII Transmit Data 1	D38	A13
MCU_RGMII1_TD2	O	RGMII Transmit Data 2	E37	B12
MCU_RGMII1_TD3	O	RGMII Transmit Data 3	E38	A12
MCU_RMII1_CRD_V	I	RMII Carrier Sense / Data Valid	C38	B14
MCU_RMII1_REF_CLK	I	RMII Reference Clock	B37	C14
MCU_RMII1_RX_ER	I	RMII Receive Data Error	C37	C12
MCU_RMII1_TX_EN	O	RMII Transmit Enable	E36	A14
MCU_RMII1_RXD0	I	RMII Receive Data 0	A35	E13
MCU_RMII1_RXD1	I	RMII Receive Data 1	B36	D14
MCU_RMII1_TXD0	O	RMII Transmit Data 0	D37	B13
MCU_RMII1_TXD1	O	RMII Transmit Data 1	D38	A13

5.3.12 SGMII

5.3.12.1 MAIN Domain

Table 5-69. CPSW9X0 Signal Descriptions

SIGNAL NAME [1]	PIN TYPE [2]	DESCRIPTION [3]	ALY PIN [4]	AND PIN [4]
SGMII1_RXN0	I	SGMII Receive (negative)	AU2, AU20	AM6
SGMII1_RXP0	I	SGMII Receive (positive)	AU21, AU3	AM7
SGMII1_TXN0	O	SGMII Transmit (negative)	AR2, AR20	AK8
SGMII1_TXP0	O	SGMII Transmit (positive)	AR21, AR3	AK9
SGMII2_RXN0	I	SGMII Receive (negative)	AT1, AT19	AL7
SGMII2_RXP0	I	SGMII Receive (positive)	AT2, AT20	AL8
SGMII2_TXN0	O	SGMII Transmit (negative)	AP1, AP19	AJ9
SGMII2_TXP0	O	SGMII Transmit (positive)	AP2, AP20	AJ10
SGMII3_RXN0	I	SGMII Receive (negative)	AU5	AL10
SGMII3_RXP0	I	SGMII Receive (positive)	AU6	AL11
SGMII3_TXN0	O	SGMII Transmit (negative)	AV6	AK11
SGMII3_TXP0	O	SGMII Transmit (positive)	AV7	AK12
SGMII4_RXN0	I	SGMII Receive (negative)	AT4	AN8
SGMII4_RXP0	I	SGMII Receive (positive)	AT5	AN9
SGMII4_TXN0	O	SGMII Transmit (negative)	AR5	AM9
SGMII4_TXP0	O	SGMII Transmit (positive)	AR6	AM10
SGMII5_RXN0	I	SGMII Receive (negative)	AR14, AU23	AN17
SGMII5_RXP0	I	SGMII Receive (positive)	AR15, AU24	AN18
SGMII5_TXN0	O	SGMII Transmit (negative)	AP13, AV24	AJ21

Table 5-69. CPSW9X0 Signal Descriptions (continued)

SIGNAL NAME [1]	PIN TYPE [2]	DESCRIPTION [3]	ALY PIN [4]	AND PIN [4]
SGMII5_TXP0	O	SGMII Transmit (positive)	AP14, AV25	AJ22
SGMII6_RXN0	I	SGMII Receive (negative)	AT22, AU14	AL19
SGMII6_RXP0	I	SGMII Receive (positive)	AT23, AU15	AL20
SGMII6_TXN0	O	SGMII Transmit (negative)	AR23, AT13	AM18
SGMII6_TXP0	O	SGMII Transmit (positive)	AR24, AT14	AM19
SGMII7_RXN0	I	SGMII Receive (negative)	AR17, AU20	AK23
SGMII7_RXP0	I	SGMII Receive (positive)	AR18, AU21	AK24
SGMII7_TXN0	O	SGMII Transmit (negative)	AR20, AT16	AN20
SGMII7_TXP0	O	SGMII Transmit (positive)	AR21, AT17	AN21
SGMII8_RXN0	I	SGMII Receive (negative)	AT19, AU17	AM21
SGMII8_RXP0	I	SGMII Receive (positive)	AT20, AU18	AM22
SGMII8_TXN0	O	SGMII Transmit (negative)	AP19, AV18	AL22
SGMII8_TXP0	O	SGMII Transmit (positive)	AP20, AV19	AL23

5.3.13 ECAP**5.3.13.1 MAIN Domain****Table 5-70. ECAP0 Signal Descriptions**

SIGNAL NAME [1]	PIN TYPE [2]	DESCRIPTION [3]	ALY PIN [4]	AND PIN [4]
ECAP0_IN_APWM_OUT	IO	Enhanced Capture (ECAP) Input or Auxiliary PWM (APWM) Output	AB34, AD36	F29, L31

Table 5-71. ECAP1 Signal Descriptions

SIGNAL NAME [1]	PIN TYPE [2]	DESCRIPTION [3]	ALY PIN [4]	AND PIN [4]
ECAP1_IN_APWM_OUT	IO	Enhanced Capture (ECAP) Input or Auxiliary PWM (APWM) Output	AA33, AR38	AA32, F28

Table 5-72. ECAP2 Signal Descriptions

SIGNAL NAME [1]	PIN TYPE [2]	DESCRIPTION [3]	ALY PIN [4]	AND PIN [4]
ECAP2_IN_APWM_OUT	IO	Enhanced Capture (ECAP) Input or Auxiliary PWM (APWM) Output	AN37	W30

5.3.14 EQEP**5.3.14.1 MAIN Domain****Table 5-73. EQEP0 Signal Descriptions**

SIGNAL NAME [1]	PIN TYPE [2]	DESCRIPTION [3]	ALY PIN [4]	AND PIN [4]
EQEP0_A	I	EQEP Quadrature Input A	AF34	U31
EQEP0_B	I	EQEP Quadrature Input B	AE34	M33
EQEP0_I	IO	EQEP Index	AD33	N32
EQEP0_S	IO	EQEP Strobe	AC34	U32

Table 5-74. EQEP1 Signal Descriptions

SIGNAL NAME [1]	PIN TYPE [2]	DESCRIPTION [3]	ALY PIN [4]	AND PIN [4]
EQEP1_A	I	EQEP Quadrature Input A	AL33	P31
EQEP1_B	I	EQEP Quadrature Input B	AL34	N31
EQEP1_I	IO	EQEP Index	AK37	E33
EQEP1_S	IO	EQEP Strobe	AD38	H29

Table 5-75. EQEP2 Signal Descriptions

SIGNAL NAME [1]	PIN TYPE [2]	DESCRIPTION [3]	ALY PIN [4]	AND PIN [4]
EQEP2_A	I	EQEP Quadrature Input A	AK33	H33
EQEP2_B	I	EQEP Quadrature Input B	AC37	J31
EQEP2_I	IO	EQEP Index	AC36	K32
EQEP2_S	IO	EQEP Strobe	AD37	P33

5.3.15 EPWM

5.3.15.1 MAIN Domain

Table 5-76. EPWM Signal Descriptions

SIGNAL NAME [1]	PIN TYPE [2]	DESCRIPTION [3]	ALY PIN [4]	AND PIN [4]
EHRPWM_SOC_A	O	EHRPWM Start of Conversion A	AE37	G32
EHRPWM_SOC_B	O	EHRPWM Start of Conversion B	AD34	M32
EHRPWM_TZn_IN0	I	EHRPWM Trip Zone Input 0 (active low)	AJ38	F31
EHRPWM_TZn_IN1	I	EHRPWM Trip Zone Input 1 (active low)	AC32	G31
EHRPWM_TZn_IN2	I	EHRPWM Trip Zone Input 2 (active low)	AK35	J30
EHRPWM_TZn_IN3	I	EHRPWM Trip Zone Input 3 (active low)	AC35	N30
EHRPWM_TZn_IN4	I	EHRPWM Trip Zone Input 4 (active low)	AF36	K33
EHRPWM_TZn_IN5	I	EHRPWM Trip Zone Input 5 (active low)	AJ37	G33

Table 5-77. EPWM0 Signal Descriptions

SIGNAL NAME [1]	PIN TYPE [2]	DESCRIPTION [3]	ALY PIN [4]	AND PIN [4]
EHRPWM0_A	IO	EHRPWM Output A	AA32, AE38, AM37	E30, G29, Y33
EHRPWM0_B	IO	EHRPWM Output B	AC38, AF38	F30, N33
EHRPWM0_SYNCI	I	Sync Input to EHRPWM module from an external pin	AH38	H31
EHRPWM0_SYNCO	O	Sync Output to EHRPWM module to an external pin	AG37	H32

Table 5-78. EPWM1 Signal Descriptions

SIGNAL NAME [1]	PIN TYPE [2]	DESCRIPTION [3]	ALY PIN [4]	AND PIN [4]
EHRPWM1_A	IO	EHRPWM Output A	AA33, AE36, AP38	F28, R32, Y32
EHRPWM1_B	IO	EHRPWM Output B	AB34, AC33	F29, G28

Table 5-79. EPWM2 Signal Descriptions

SIGNAL NAME [1]	PIN TYPE [2]	DESCRIPTION [3]	ALY PIN [4]	AND PIN [4]
EHRPWM2_A	IO	EHRPWM Output A	AB36, AF37, AN38	E32, F32, V31
EHRPWM2_B	IO	EHRPWM Output B	AB38, AK38	D33, K31

Table 5-80. EPWM3 Signal Descriptions

SIGNAL NAME [1]	PIN TYPE [2]	DESCRIPTION [3]	ALY PIN [4]	AND PIN [4]
EHRPWM3_A	IO	EHRPWM Output A	AC38, AE35, AM35	F30, M31, V30
EHRPWM3_B	IO	EHRPWM Output B	AF35	P30
EHRPWM3_SYNCI	I	Sync Input to EHRPWM module from an external pin	AH36	L32
EHRPWM3_SYNCO	O	Sync Output to EHRPWM module to an external pin	AG35	T33

Table 5-81. EPWM4 Signal Descriptions

SIGNAL NAME [1]	PIN TYPE [2]	DESCRIPTION [3]	ALY PIN [4]	AND PIN [4]
EHRPWM4_A	IO	EHRPWM Output A	AB34, AJ36, AM36	F29, L33, W31
EHRPWM4_B	IO	EHRPWM Output B	AH37	F33

Table 5-82. EPWM5 Signal Descriptions

SIGNAL NAME [1]	PIN TYPE [2]	DESCRIPTION [3]	ALY PIN [4]	AND PIN [4]
EHRPWM5_A	IO	EHRPWM Output A	AB38, AG38	D33, H30
EHRPWM5_B	IO	EHRPWM Output B	AK34	J32

5.3.16 USB**5.3.16.1 MAIN Domain****Table 5-83. USB0 Signal Descriptions**

SIGNAL NAME [1]	PIN TYPE [2]	DESCRIPTION [3]	ALY PIN [4]	AND PIN [4]
USB0_DM	IO	USB 2.0 Differential Data (negative)	AP16	AH16
USB0_DP	IO	USB 2.0 Differential Data (positive)	AP17	AH17
USB0_DRVVBUS	O	USB VBUS Control Output (active high)	AE35, AL32, AN37	M31, P32, W30
USB0_ID	A	USB 2.0 Dual-Role Device Role Select	AN17	AH20
USB0_RCALIB ⁽¹⁾	A	Pin to connect to calibration resistor	AN18	AH22
USB0_VBUS ⁽²⁾	A	USB Level-shifted VBUS Detector	AN15	AG19
USB0_SSRX1N	I	SERDES_USB Differential Receive Data (negative)	AR11, AR17	AK23, AN15
USB0_SSRX1P	I	SERDES_USB Differential Receive Data (positive)	AR12, AR18	AK24, AN14
USB0_SSRX2N	I	SERDES_USB Differential Receive Data (negative)	AU11, AU17	AL17, AM21
USB0_SSRX2P	I	SERDES_USB Differential Receive Data (positive)	AU12, AU18	AL16, AM22
USB0_SSTX1N	O	SERDES_USB Differential Transmit Data (negative)	AT16, AV9	AM16, AN20
USB0_SSTX1P	O	SERDES_USB Differential Transmit Data (positive)	AT17, AV10	AM15, AN21
USB0_SSTX2N	O	SERDES_USB Differential Transmit Data (negative)	AV12, AV18	AK18, AL22
USB0_SSTX2P	O	SERDES_USB Differential Transmit Data (positive)	AV13, AV19	AK17, AL23

(1) An external 500 Ω ±1% resistor must be connected between this pin and VSS, even when the pin is unused

(2) An external resistor divider is required to limit the voltage applied to the device pin. For more information, see *USB VBUS Design Guidelines*.

5.3.17 Display Port**5.3.17.1 MAIN Domain****Table 5-84. DP0 Signal Descriptions**

SIGNAL NAME [1]	PIN TYPE [2]	DESCRIPTION [3]	ALY PIN [4]	AND PIN [4]
DP0_AUXN	IO	Display Port Differential Auxiliary Data (negative)	AP22	AJ25
DP0_AUXP	IO	Display Port Differential Auxiliary Data (positive)	AP23	AJ24
DP0_HPDP	I	Display Port Hot Plug Detection	AC34, AG33, AM37	R33, U32, Y33
DP0_TXN0	O	Display Port Differential Transmit (negative)	AP13	AJ21
DP0_TXN1	O	Display Port Differential Transmit (negative)	AT13	AM18

Table 5-84. DP0 Signal Descriptions (continued)

SIGNAL NAME [1]	PIN TYPE [2]	DESCRIPTION [3]	ALY PIN [4]	AND PIN [4]
DP0_TXN2	O	Display Port Differential Transmit (negative)	AT16	AN20
DP0_TXN3	O	Display Port Differential Transmit (negative)	AV18	AL22
DP0_TXP0	O	Display Port Differential Transmit (positive)	AP14	AJ22
DP0_TXP1	O	Display Port Differential Transmit (positive)	AT14	AM19
DP0_TXP2	O	Display Port Differential Transmit (positive)	AT17	AN21
DP0_TXP3	O	Display Port Differential Transmit (positive)	AV19	AL23

5.3.18 PCIE

5.3.18.1 MAIN Domain

Table 5-85. PCIE Signal Descriptions

SIGNAL NAME [1]	PIN TYPE [2]	DESCRIPTION [3]	ALY PIN [4]	AND PIN [4]
PCIE0_CLKREQn	IO	PCIE Clock Request Signal	AC34	U32
PCIE1_CLKREQn	IO	PCIE Clock Request Signal	AC38, AR38	AA32, F30
PCIE2_CLKREQn	IO	PCIE Clock Request Signal	AB38, AL33	D33, P31
PCIE3_CLKREQn	IO	PCIE Clock Request Signal	AB36, AL34	E32, N31
PCIE0_RXN0	I	SERDES_PCIE Differential Receive Data (negative)	AU5	AL10
PCIE0_RXN1	I	SERDES_PCIE Differential Receive Data (negative)	AT4	AN8
PCIE0_RXN2	I	SERDES_PCIE Differential Receive Data (negative)	AU2	AM6
PCIE0_RXN3	I	SERDES_PCIE Differential Receive Data (negative)	AT1	AL7
PCIE0_RXP0	I	SERDES_PCIE Differential Receive Data (positive)	AU6	AL11
PCIE0_RXP1	I	SERDES_PCIE Differential Receive Data (positive)	AT5	AN9
PCIE0_RXP2	I	SERDES_PCIE Differential Receive Data (positive)	AU3	AM7
PCIE0_RXP3	I	SERDES_PCIE Differential Receive Data (positive)	AT2	AL8
PCIE0_TXN0	O	SERDES_PCIE Differential Transmit Data (negative)	AV6	AK11
PCIE0_TXN1	O	SERDES_PCIE Differential Transmit Data (negative)	AR5	AM9
PCIE0_TXN2	O	SERDES_PCIE Differential Transmit Data (negative)	AR2	AK8
PCIE0_TXN3	O	SERDES_PCIE Differential Transmit Data (positive)	AP1	AJ9
PCIE0_TXP0	O	SERDES_PCIE Differential Transmit Data (positive)	AV7	AK12
PCIE0_TXP1	O	SERDES_PCIE Differential Transmit Data (positive)	AR6	AM10
PCIE0_TXP2	O	SERDES_PCIE Differential Transmit Data (positive)	AR3	AK9
PCIE0_TXP3	O	SERDES_PCIE Differential Transmit Data (positive)	AP2	AJ10
PCIE1_RXN0	I	SERDES_PCIE Differential Receive Data (negative)	AR8	AM12
PCIE1_RXN1	I	SERDES_PCIE Differential Receive Data (negative)	AT10	AL13

Table 5-85. PCIE Signal Descriptions (continued)

SIGNAL NAME [1]	PIN TYPE [2]	DESCRIPTION [3]	ALY PIN [4]	AND PIN [4]
PCIE1_RXN2	I	SERDES_PCIE Differential Receive Data (negative)	AR11	AN15
PCIE1_RXN3	I	SERDES_PCIE Differential Receive Data (negative)	AU11	AL17
PCIE1_RXP0	I	SERDES_PCIE Differential Receive Data (positive)	AR9	AM13
PCIE1_RXP1	I	SERDES_PCIE Differential Receive Data (positive)	AT11	AL14
PCIE1_RXP2	I	SERDES_PCIE Differential Receive Data (positive)	AR12	AN14
PCIE1_RXP3	I	SERDES_PCIE Differential Receive Data (positive)	AU12	AL16
PCIE1_TXN0	O	SERDES_PCIE Differential Transmit Data (negative)	AT7	AN11
PCIE1_TXN1	O	SERDES_PCIE Differential Transmit Data (negative)	AP10	AJ19
PCIE1_TXN2	O	SERDES_PCIE Differential Transmit Data (negative)	AV9	AM16
PCIE1_TXN3	O	SERDES_PCIE Differential Transmit Data (negative)	AV12	AK18
PCIE1_TXP0	O	SERDES_PCIE Differential Transmit Data (positive)	AT8	AN12
PCIE1_TXP1	O	SERDES_PCIE Differential Transmit Data (positive)	AP11	AJ18
PCIE1_TXP2	O	SERDES_PCIE Differential Transmit Data (positive)	AV10	AM15
PCIE1_TXP3	O	SERDES_PCIE Differential Transmit Data (positive)	AV13	AK17
PCIE2_RXN0	I	SERDES_PCIE Differential Receive Data (negative)	AU2	AM6
PCIE2_RXN1	I	SERDES_PCIE Differential Receive Data (negative)	AT1	AL7
PCIE2_RXP0	I	SERDES_PCIE Differential Receive Data (positive)	AU3	AM7
PCIE2_RXP1	I	SERDES_PCIE Differential Receive Data (positive)	AT2	AL8
PCIE2_TXN0	O	SERDES_PCIE Differential Transmit Data (negative)	AR2	AK8
PCIE2_TXN1	O	SERDES_PCIE Differential Transmit Data (negative)	AP1	AJ9
PCIE2_TXP0	O	SERDES_PCIE Differential Transmit Data (negative)	AR3	AK9
PCIE2_TXP1	O	SERDES_PCIE Differential Transmit Data (positive)	AP2	AJ10
PCIE3_RXN0	I	SERDES_PCIE Differential Receive Data (negative)	AR11	AN15
PCIE3_RXN1	I	SERDES_PCIE Differential Receive Data (negative)	AU11	AL17
PCIE3_RXP0	I	SERDES_PCIE Differential Receive Data (positive)	AR12	AN14
PCIE3_RXP1	I	SERDES_PCIE Differential Receive Data (positive)	AU12	AL16
PCIE3_TXN0	O	SERDES_PCIE Differential Transmit Data (negative)	AV9	AM16

Table 5-85. PCIE Signal Descriptions (continued)

SIGNAL NAME [1]	PIN TYPE [2]	DESCRIPTION [3]	ALY PIN [4]	AND PIN [4]
PCIE3_TXN1	O	SERDES_PCIE Differential Transmit Data (negative)	AV12	AK18
PCIE3_TXP0	O	SERDES_PCIE Differential Transmit Data (positive)	AV10	AM15
PCIE3_TXP1	O	SERDES_PCIE Differential Transmit Data (positive)	AV13	AK17
PCIE_REFCLK0_N_OUT	O	SERDES_PCIE Reference Clock Negative	AP4	AJ13
PCIE_REFCLK0_P_OUT	O	SERDES_PCIE Reference Clock Positive	AP5	AJ12
PCIE_REFCLK1_N_OUT	O	SERDES_PCIE Reference Clock Out Negative	AN8	AH14
PCIE_REFCLK1_P_OUT	O	SERDES_PCIE Reference Clock Out Positive	AN9	AH13
PCIE_REFCLK2_N_OUT	O	SERDES_PCIE Reference Clock Out Negative	AN5	AH11
PCIE_REFCLK2_P_OUT	O	SERDES_PCIE Reference Clock Out Positive	AN6	AH10
PCIE_REFCLK3_N_OUT	O	SERDES_PCIE Reference Clock Out Negative	AP7	AJ16
PCIE_REFCLK3_P_OUT	O	SERDES_PCIE Reference Clock Out Positive	AP8	AJ15

5.3.19 SERDES

5.3.19.1 MAIN Domain

Table 5-86. SERDES0 Signal Descriptions

SIGNAL NAME [1]	PIN TYPE [2]	DESCRIPTION [3]	ALY PIN [4]	AND PIN [4]
SERDES0_REFCLK_N	IO	Serdes Reference Clock Input/Output (negative)	AU9	AK15
SERDES0_REFCLK_P	IO	Serdes Reference Clock Input/Output (positive)	AU8	AK14
SERDES0_REXT ⁽¹⁾	I	External Calibration Resistor	AN11	AG7

(1) An external 3.01 kΩ ±1% resistor must be connected between this pin and VSS. No external voltage should be applied to this pin.

Table 5-87. SERDES1 Signal Descriptions

SIGNAL NAME [1]	PIN TYPE [2]	DESCRIPTION [3]	ALY PIN [4]	AND PIN [4]
SERDES1_REFCLK_N	IO	Serdes Reference Clock Input/Output (negative)	AV3	AN5
SERDES1_REFCLK_P	IO	Serdes Reference Clock Input/Output (positive)	AV4	AN6
SERDES1_REXT ⁽¹⁾	I	External Calibration Resistor	AL9	AH9

(1) An external 3.01 kΩ ±1% resistor must be connected between this pin and VSS. No external voltage should be applied to this pin.

Table 5-88. SERDES2 Signal Descriptions

SIGNAL NAME [1] ⁽²⁾	PIN TYPE [2]	DESCRIPTION [3]	ALY PIN [4]	AND PIN [4]
SERDES2_REFCLK_N	IO	Serdes Reference Clock Input/Output (negative)	AV21	
SERDES2_REFCLK_P	IO	Serdes Reference Clock Input/Output (positive)	AV22	
SERDES2_REXT ⁽¹⁾	IO	External Calibration Resistor	AL20	

(1) An external 3.01 kΩ ±1% resistor must be connected between this pin and VSS. No external voltage should be applied to this pin.

(2) DDRSS2, DDRSS3, and SERDES2 are not available on the 27mm package variant of this SoC. DDRSS2/DDRSS3/SERDES2 should be avoided if software compatibility is desired with systems that use the 27mm package.

Table 5-89. SERDES4 Signal Descriptions

SIGNAL NAME [1]	PIN TYPE [2]	DESCRIPTION [3]	ALY PIN [4]	AND PIN [4]
SERDES4_REFCLK_N	IO	Serdes Reference Clock Input/Output (negative)	AV16	AK21
SERDES4_REFCLK_P	IO	Serdes Reference Clock Input/Output (positive)	AV15	AK20
SERDES4_REXT ⁽¹⁾	IO	External Calibration Resistor	AM19	AH23

(1) An external 3.01 kΩ ±1% resistor must be connected between this pin and VSS. No external voltage should be applied to this pin.

5.3.20 DSI

5.3.20.1 MAIN Domain

Table 5-90. DSI0 Signal Descriptions

SIGNAL NAME [1]	PIN TYPE [2]	DESCRIPTION [3]	ALY PIN [4]	AND PIN [4]
CSI0_TXCLKN	O	CSI Differential Transmit Clock Output (negative)	AP26	AJ28
CSI0_TXCLKP	O	CSI Differential Transmit Clock Output (positive)	AP25	AJ27
CSI0_TXN0	O	CSI Differential Transmit Output (negative)	AU27	AL26
CSI0_TXN1	O	CSI Differential Transmit Output (negative)	AT26	AK27
CSI0_TXN2	O	CSI Differential Transmit Output (negative)	AR27	AM25
CSI0_TXN3	O	CSI Differential Transmit Output (negative)	AN24	AN24
CSI0_TXP0	O	CSI Differential Transmit Output (positive)	AU26	AL25
CSI0_TXP1	O	CSI Differential Transmit Output (positive)	AT25	AK26
CSI0_TXP2	O	CSI Differential Transmit Output (positive)	AR26	AM24
CSI0_TXP3	O	CSI Differential Transmit Output (positive)	AN23	AN23
DSI0_TXCLKN	O	DSI Transmit clock (negative)	AP26	AJ28
DSI0_TXCLKP	O	DSI Transmit clock (positive)	AP25	AJ27
DSI0_TXRCALIB ⁽¹⁾	A	DSI Transmit Calibration Resistor	AM24	AH25
DSI0_TXN0	IO	DSI Transmit (negative)	AU27	AL26
DSI0_TXN1	O	DSI Transmit (negative)	AT26	AK27
DSI0_TXN2	O	DSI Transmit (negative)	AR27	AM25
DSI0_TXN3	O	DSI Transmit (negative)	AN24	AN24
DSI0_TXP0	IO	DSI Transmit (positive)	AU26	AL25
DSI0_TXP1	O	DSI Transmit (positive)	AT25	AK26
DSI0_TXP2	O	DSI Transmit (positive)	AR26	AM24
DSI0_TXP3	O	DSI Transmit (positive)	AN23	AN23

(1) An external 500 Ω ±1% resistor must be connected between this pin and VSS, even when the pin is unused.

Table 5-91. DSI1 Signal Descriptions

SIGNAL NAME [1]	PIN TYPE [2]	DESCRIPTION [3]	ALY PIN [4]	AND PIN [4]
CSI1_TXCLKN	O	CSI Differential Transmit Clock Output (negative)	AP29	AJ31
CSI1_TXCLKP	O	CSI Differential Transmit Clock Output (positive)	AP28	AJ30
CSI1_TXN0	O	CSI Differential Transmit Output (negative)	AT29	AK30
CSI1_TXN1	O	CSI Differential Transmit Output (negative)	AN27	AL29
CSI1_TXN2	O	CSI Differential Transmit Output (negative)	AV28	AM28
CSI1_TXN3	O	CSI Differential Transmit Output (negative)	AU30	AN27
CSI1_TXP0	O	CSI Differential Transmit Output (positive)	AT28	AK29

Table 5-91. DSI1 Signal Descriptions (continued)

SIGNAL NAME [1]	PIN TYPE [2]	DESCRIPTION [3]	ALY PIN [4]	AND PIN [4]
CSI1_TXP1	O	CSI Differential Transmit Output (positive)	AN26	AL28
CSI1_TXP2	O	CSI Differential Transmit Output (positive)	AV27	AM27
CSI1_TXP3	O	CSI Differential Transmit Output (positive)	AU29	AN26
DSI1_TXCLKN	O	DSI Transmit clock (negative)	AP29	AJ31
DSI1_TXCLKP	O	DSI Transmit clock (positive)	AP28	AJ30
DSI1_TXRCALIB ⁽¹⁾	A	DSI Transmit Calibration Resistor	AL22	AH27
DSI1_TXN0	IO	DSI Transmit (negative)	AT29	AK30
DSI1_TXN1	O	DSI Transmit (negative)	AN27	AL29
DSI1_TXN2	O	DSI Transmit (negative)	AV28	AM28
DSI1_TXN3	O	DSI Transmit (negative)	AU30	AN27
DSI1_TXP0	IO	DSI Transmit (positive)	AT28	AK29
DSI1_TXP1	O	DSI Transmit (positive)	AN26	AL28
DSI1_TXP2	O	DSI Transmit (positive)	AV27	AM27
DSI1_TXP3	O	DSI Transmit (positive)	AU29	AN26

(1) An external 500 Ω ±1% resistor must be connected between this pin and VSS, even when the pin is unused.

5.3.21 CSI

5.3.21.1 MAIN Domain

Table 5-92. CSI0 Signal Descriptions

SIGNAL NAME [1]	PIN TYPE [2]	DESCRIPTION [3]	ALY PIN [4]	AND PIN [4]
CSI0_RXCLKN	I	CSI Differential Receive Clock Input (negative)	AN30	AH33
CSI0_RXCLKP	I	CSI Differential Receive Clock Input (positive)	AN29	AH32
CSI0_RXRCALIB ⁽¹⁾	A	CSI Pin connected to external resistor for on-chip resistor calibration	AM28	AH31
CSI0_RXN0	I	CSI Differential Receive Input (negative)	AU33	AL32
CSI0_RXN1	I	CSI Differential Receive Input (negative)	AT32	AM31
CSI0_RXN2	I	CSI Differential Receive Input (negative)	AV31	AN30
CSI0_RXN3	I	CSI Differential Receive Input (negative)	AR30	AK33
CSI0_RXP0	I	CSI Differential Receive Input (positive)	AU32	AL31
CSI0_RXP1	I	CSI Differential Receive Input (positive)	AT31	AM30
CSI0_RXP2	I	CSI Differential Receive Input (positive)	AV30	AN29
CSI0_RXP3	I	CSI Differential Receive Input (positive)	AR29	AK32

(1) An external 500 Ω ±1% resistor must be connected between this pin and VSS, even when the pin is unused.

Table 5-93. CSI1 Signal Descriptions

SIGNAL NAME [1]	PIN TYPE [2]	DESCRIPTION [3]	ALY PIN [4]	AND PIN [4]
CSI1_RXCLKN	I	CSI Differential Receive Clock Input (negative)	AP32	AE29
CSI1_RXCLKP	I	CSI Differential Receive Clock Input (positive)	AP31	AF29
CSI1_RXRCALIB ⁽¹⁾	A	CSI pin connected to external resistor for on-chip resistor calibration	AL28	AJ33
CSI1_RXN0	I	CSI Differential Receive Input (negative)	AT35	AF30
CSI1_RXN1	I	CSI Differential Receive Input (negative)	AU36	AE33
CSI1_RXN2	I	CSI Differential Receive Input (negative)	AR33	AE31
CSI1_RXN3	I	CSI Differential Receive Input (negative)	AV34	AF32
CSI1_RXP0	I	CSI Differential Receive Input (positive)	AT34	AG30

Table 5-93. CSI1 Signal Descriptions (continued)

SIGNAL NAME [1]	PIN TYPE [2]	DESCRIPTION [3]	ALY PIN [4]	AND PIN [4]
CSI1_RXP1	I	CSI Differential Receive Input (positive)	AU35	AF33
CSI1_RXP2	I	CSI Differential Receive Input (positive)	AR32	AF31
CSI1_RXP3	I	CSI Differential Receive Input (positive)	AV33	AG32

(1) An external 500 Ω \pm 1% resistor must be connected between this pin and VSS, even when the pin is unused.

Table 5-94. CSI2 Signal Descriptions

SIGNAL NAME [1]	PIN TYPE [2]	DESCRIPTION [3]	ALY PIN [4]	AND PIN [4]
CSI2_RXCLKN	I	CSI Differential Receive Clock Input (negative)	AN32	AC29
CSI2_RXCLKP	I	CSI Differential Receive Clock Input (positive)	AN33	AB29
CSI2_RXRCALIB ⁽¹⁾	A	CSI Pin connected to external resistor for on-chip resistor calibration	AM31	AH29
CSI2_RXN0	I	CSI Differential Receive Input (negative)	AR36	AC30
CSI2_RXN1	I	CSI Differential Receive Input (negative)	AT38	AB31
CSI2_RXN2	I	CSI Differential Receive Input (negative)	AP35	AC32
CSI2_RXN3	I	CSI Differential Receive Input (negative)	AV37	AB33
CSI2_RXP0	I	CSI Differential Receive Input (positive)	AR35	AD30
CSI2_RXP1	I	CSI Differential Receive Input (positive)	AT37	AC31
CSI2_RXP2	I	CSI Differential Receive Input (positive)	AP34	AD32
CSI2_RXP3	I	CSI Differential Receive Input (positive)	AV36	AC33

(1) An external 500 Ω \pm 1% resistor must be connected between this pin and VSS, even when the pin is unused.

5.3.22 MCASP

5.3.22.1 MAIN Domain

Table 5-95. MCASP0 Signal Descriptions

SIGNAL NAME [1]	PIN TYPE [2]	DESCRIPTION [3]	ALY PIN [4]	AND PIN [4]
MCASP0_ACLKR	IO	MCASP Receive Bit Clock	AF34	U31
MCASP0_ACLKX	IO	MCASP Transmit Bit Clock	AK35	J30
MCASP0_AFSR	IO	MCASP Receive Frame Sync	AE34	M33
MCASP0_AFSX	IO	MCASP Transmit Frame Sync	AK38	K31
MCASP0_AXR0	IO	MCASP Serial Data (Input/Output)	AF37	F32
MCASP0_AXR1	IO	MCASP Serial Data (Input/Output)	AG37	H32
MCASP0_AXR2	IO	MCASP Serial Data (Input/Output)	AK33	H33
MCASP0_AXR3	IO	MCASP Serial Data (Input/Output)	AJ38	F31
MCASP0_AXR4	IO	MCASP Serial Data (Input/Output)	AK34	J32
MCASP0_AXR5	IO	MCASP Serial Data (Input/Output)	AG38	H30
MCASP0_AXR6	IO	MCASP Serial Data (Input/Output)	AF36	K33
MCASP0_AXR7	IO	MCASP Serial Data (Input/Output)	AE35	M31
MCASP0_AXR8	IO	MCASP Serial Data (Input/Output)	AC35	N30
MCASP0_AXR9	IO	MCASP Serial Data (Input/Output)	AG35	T33
MCASP0_AXR10	IO	MCASP Serial Data (Input/Output)	AH36	L32
MCASP0_AXR11	IO	MCASP Serial Data (Input/Output)	AF35	P30
MCASP0_AXR12	IO	MCASP Serial Data (Input/Output)	AD34	M32
MCASP0_AXR13	IO	MCASP Serial Data (Input/Output)	AJ36	L33
MCASP0_AXR14	IO	MCASP Serial Data (Input/Output)	AF34	U31
MCASP0_AXR15	IO	MCASP Serial Data (Input/Output)	AE34	M33

Table 5-96. MCASP1 Signal Descriptions

SIGNAL NAME [1]	PIN TYPE [2]	DESCRIPTION [3]	ALY PIN [4]	AND PIN [4]
MCASP1_ACLKR	IO	MCASP Receive Bit Clock	AG38	H30
MCASP1_ACLKX	IO	MCASP Transmit Bit Clock	AC34	U32
MCASP1_AFSR	IO	MCASP Receive Frame Sync	AF36	K33
MCASP1_AFSX	IO	MCASP Transmit Frame Sync	AD33	N32
MCASP1_AXR0	IO	MCASP Serial Data (Input/Output)	AD38	H29
MCASP1_AXR1	IO	MCASP Serial Data (Input/Output)	AC32	G31
MCASP1_AXR2	IO	MCASP Serial Data (Input/Output)	AC37	J31
MCASP1_AXR3	IO	MCASP Serial Data (Input/Output)	AL33	P31
MCASP1_AXR4	IO	MCASP Serial Data (Input/Output)	AL34	N31

Table 5-97. MCASP2 Signal Descriptions

SIGNAL NAME [1]	PIN TYPE [2]	DESCRIPTION [3]	ALY PIN [4]	AND PIN [4]
MCASP2_ACLKR	IO	MCASP Receive Bit Clock	AD34	M32
MCASP2_ACLKX	IO	MCASP Transmit Bit Clock	AD37	P33
MCASP2_AFSR	IO	MCASP Receive Frame Sync	AJ36	L33
MCASP2_AFSX	IO	MCASP Transmit Frame Sync	AE37	G32
MCASP2_AXR0	IO	MCASP Serial Data (Input/Output)	AC36	K32
MCASP2_AXR1	IO	MCASP Serial Data (Input/Output)	AE36	R32
MCASP2_AXR2	IO	MCASP Serial Data (Input/Output)	AF38	N33
MCASP2_AXR3	IO	MCASP Serial Data (Input/Output)	AC33	G28
MCASP2_AXR4	IO	MCASP Serial Data (Input/Output)	AF34	U31

Table 5-98. MCASP3 Signal Descriptions

SIGNAL NAME [1]	PIN TYPE [2]	DESCRIPTION [3]	ALY PIN [4]	AND PIN [4]
MCASP3_ACLKR	IO	MCASP Receive Bit Clock	AM37	Y33
MCASP3_ACLKX	IO	MCASP Transmit Bit Clock	AM37	Y33
MCASP3_AFSR	IO	MCASP Receive Frame Sync	AP38	Y32
MCASP3_AFSX	IO	MCASP Transmit Frame Sync	AP38	Y32
MCASP3_AXR0	IO	MCASP Serial Data (Input/Output)	AN38	V31
MCASP3_AXR1	IO	MCASP Serial Data (Input/Output)	AM35	V30
MCASP3_AXR2	IO	MCASP Serial Data (Input/Output)	AM36	W31

Table 5-99. MCASP4 Signal Descriptions

SIGNAL NAME [1]	PIN TYPE [2]	DESCRIPTION [3]	ALY PIN [4]	AND PIN [4]
MCASP4_ACLKR	IO	MCASP Receive Bit Clock	AE35	M31
MCASP4_ACLKX	IO	MCASP Transmit Bit Clock	AJ32	J33
MCASP4_AFSR	IO	MCASP Receive Frame Sync	AC35	N30
MCASP4_AFSX	IO	MCASP Transmit Frame Sync	AJ37	G33
MCASP4_AXR0	IO	MCASP Serial Data (Input/Output)	AJ34	T30
MCASP4_AXR1	IO	MCASP Serial Data (Input/Output)	AE38	G29
MCASP4_AXR2	IO	MCASP Serial Data (Input/Output)	AD36	L31
MCASP4_AXR3	IO	MCASP Serial Data (Input/Output)	AH38	H31
MCASP4_AXR4	IO	MCASPI Serial Data (Input/Output)	AG35	T33

5.3.23 DMTIMER

5.3.23.1 MAIN Domain

Table 5-100. DMTIMER Signal Descriptions

SIGNAL NAME [1]	PIN TYPE [2]	DESCRIPTION [3]	ALY PIN [4]	AND PIN [4]
TIMER_IO0	IO	Timer Inputs and Outputs (Can be used with any MAIN domain timer instance)	AR38	AA32
TIMER_IO1	IO	Timer Inputs and Outputs (Can be used with any MAIN domain timer instance)	AN37	W30
TIMER_IO2	IO	Timer Inputs and Outputs (Can be used with any MAIN domain timer instance)	AC38	F30
TIMER_IO3	IO	Timer Inputs and Outputs (Can be used with any MAIN domain timer instance)	AA32	E30
TIMER_IO4	IO	Timer Inputs and Outputs (Can be used with any MAIN domain timer instance)	AB34	F29
TIMER_IO5	IO	Timer Inputs and Outputs (Can be used with any MAIN domain timer instance)	AA33	F28
TIMER_IO6	IO	Timer Inputs and Outputs (Can be used with any MAIN domain timer instance)	AB38	D33
TIMER_IO7	IO	Timer Inputs and Outputs (Can be used with any MAIN domain timer instance)	AB36	E32

5.3.23.2 MCU Domain

Table 5-101. MCU_DMTIMER Signal Descriptions

SIGNAL NAME [1]	PIN TYPE [2]	DESCRIPTION [3]	ALY PIN [4]	AND PIN [4]
MCU_TIMER_IO0	IO	Timer Inputs and Outputs (Can be used with any MCU domain timer instance.)	G33, J38	A9, E14
MCU_TIMER_IO1	IO	Timer Inputs and Outputs (Can be used with any MCU domain timer instance.)	F37, M38	B21, E19
MCU_TIMER_IO2	IO	Timer Inputs and Outputs (Can be used with any MCU domain timer instance.)	E38	A12
MCU_TIMER_IO3	IO	Timer Inputs and Outputs (Can be used with any MCU domain timer instance.)	E37	B12
MCU_TIMER_IO4	IO	Timer Inputs and Outputs (Can be used with any MCU domain timer instance.)	D36	D13
MCU_TIMER_IO5	IO	Timer Inputs and Outputs (Can be used with any MCU domain timer instance.)	C36	D12
MCU_TIMER_IO6	IO	Timer Inputs and Outputs (Can be used with any MCU domain timer instance.)	L35, M37	A19, B19
MCU_TIMER_IO7	IO	Timer Inputs and Outputs (Can be used with any MCU domain timer instance.)	L34, M36	A15, B20
MCU_TIMER_IO8	IO	Timer Inputs and Outputs (Can be used with any MCU domain timer instance.)	H37	D15
MCU_TIMER_IO9	IO	Timer Inputs and Outputs (Can be used with any MCU domain timer instance.)	K37	C16

5.3.24 CPTS

5.3.24.1 MAIN Domain

Table 5-102. CPTS0 Signal Descriptions

SIGNAL NAME [1]	PIN TYPE [2]	DESCRIPTION [3]	ALY PIN [4]	AND PIN [4]
CPTS0_RFT_CLK	I	CPTS Reference Clock	AD36	L31
CPTS0_TS_COMP	O	CPTS Time Stamp Counter Compare	AP38	Y32
CPTS0_TS_SYNC	O	CPTS Time Stamp Counter Bit	AA32	E30

Table 5-102. CPTS0 Signal Descriptions (continued)

SIGNAL NAME [1]	PIN TYPE [2]	DESCRIPTION [3]	ALY PIN [4]	AND PIN [4]
CPTS0_HW1TSPUSH	I	CPTS Hardware Time Stamp Push 1	AD36	L31
CPTS0_HW2TSPUSH	I	CPTS Hardware Time Stamp Push 2	AJ32	J33

5.3.24.2 MCU Domain

Table 5-103. MCU_CPTS0 Signal Descriptions

SIGNAL NAME [1]	PIN TYPE [2]	DESCRIPTION [3]	ALY PIN [4]	AND PIN [4]
MCU_CPTS0_RFT_CLK	I	CPTS Reference Clock	L33, M33	A20, B18
MCU_CPTS0_TS_COMP	O	CPTS Time Stamp Counter Compare	L34	A15
MCU_CPTS0_TS_SYNC	O	CPTS Time Stamp Counter Bit	L35	B19
MCU_CPTS0_HW1TSPUSH	I	CPTS Hardware Time Stamp Push 1	L37	B15
MCU_CPTS0_HW2TSPUSH	I	CPTS Hardware Time Stamp Push 2	L36	B17

5.3.25 DSS

5.3.25.1 MAIN Domain

Table 5-104. DSS0 Signal Descriptions

SIGNAL NAME [1]	PIN TYPE [2]	DESCRIPTION [3]	ALY PIN [4]	AND PIN [4]
DSS_FSYNC0	O	Video Output Frame Sync	AG36, AJ37	G33, P29
DSS_FSYNC1	O	Video Output Frame Sync	AJ33, AJ34	T29, T30
DSS_FSYNC2	O	Video Output Frame Sync	AF33, AF35	P30, T31
DSS_FSYNC3	O	Video Output Frame Sync	AD34, AH33	M32, T32
VOU0_DE	O	Video Output Data Enable	AG38	H30
VOU0_EXTPCLKIN	I	Video Output External Pixel Clock Input	AJ37	G33
VOU0_HSYNC	O	Video Output Horizontal Sync	AK34	J32
VOU0_PCLK	O	Video Output Pixel Clock Output	AH37	F33
VOU0_VSYNC	O	Video Output Vertical Sync	AF36	K33
VOU0_DATA0	O	Video Output Data 0	AC33	G28
VOU0_DATA1	O	Video Output Data 1	AH38	H31
VOU0_DATA2	O	Video Output Data 2	AJ38	F31
VOU0_DATA3	O	Video Output Data 3	AE38	G29
VOU0_DATA4	O	Video Output Data 4	AF38	N33
VOU0_DATA5	O	Video Output Data 5	AE36	R32
VOU0_DATA6	O	Video Output Data 6	AC36	K32
VOU0_DATA7	O	Video Output Data 7	AE37	G32
VOU0_DATA8	O	Video Output Data 8	AD37	P33
VOU0_DATA9	O	Video Output Data 9	AC37	J31
VOU0_DATA10	O	Video Output Data 10	AC32	G31
VOU0_DATA11	O	Video Output Data 11	AK33	H33
VOU0_DATA12	O	Video Output Data 12	AG37	H32
VOU0_DATA13	O	Video Output Data 13	AF37	F32
VOU0_DATA14	O	Video Output Data 14	AK38	K31
VOU0_DATA15	O	Video Output Data 15	AK35	J30
VOU0_DATA16	O	Video Output Data 16	AJ32	J33
VOU0_DATA17	O	Video Output Data 17	AK37	E33
VOU0_DATA18	O	Video Output Data 18	AC33, AL32	G28, P32
VOU0_DATA19	O	Video Output Data 19	AE33, AH38	H31, U30

Table 5-104. DSS0 Signal Descriptions (continued)

SIGNAL NAME [1]	PIN TYPE [2]	DESCRIPTION [3]	ALY PIN [4]	AND PIN [4]
VOUT0_DATA20	O	Video Output Data 20	AD37, AH34	G30, P33
VOUT0_DATA21	O	Video Output Data 21	AC37, AJ35	J31, R31
VOUT0_DATA22	O	Video Output Data 22	AG34, AK37	E33, R29
VOUT0_DATA23	O	Video Output Data 23	AD36, AK36	L31, R30
VOUT0_VP0_DE	O	Alternative Output Data Enable	AG38	H30
VOUT0_VP0_HSYNC	O	Alternative Output Horizontal Sync	AK34	J32
VOUT0_VP0_VSYNC	O	Alternative Output Vertical Sync	AF36	K33
VOUT0_VP2_DE	O	Alternative Output Data Enable	AG38	H30
VOUT0_VP2_HSYNC	O	Alternative Output Horizontal Sync	AK34	J32
VOUT0_VP2_VSYNC	O	Alternative Output Vertical Sync	AF36	K33

5.3.26 GPMC**5.3.26.1 MAIN Domain****Table 5-105. GPMC0 Signal Descriptions**

SIGNAL NAME [1]	PIN TYPE [2]	DESCRIPTION [3]	ALY PIN [4]	AND PIN [4]
GPMC0_ADVn_ALE	O	GPMC Address Valid (active low) or Address Latch Enable	AK33	H33
GPMC0_CLK	IO	GPMC clock	AG36	P29
GPMC0_CLKOUT	O	GPMC clock generated for external synchronization	AF36	K33
GPMC0_DIR	O	GPMC Data Bus Signal Direction Control	AC33, AH37	F33, G28
GPMC0_OEn_REn	O	GPMC Output Enable (active low) or Read Enable (active low)	AK34	J32
GPMC0_WEn	O	GPMC Write Enable (active low)	AJ34	T30
GPMC0_WPn	O	GPMC Flash Write Protect (active low)	AK33	H33
GPMC0_A0	OZ	GPMC Address 0 Output. Only used to effectively address 8-bit data non-multiplexed memories	AE35	M31
GPMC0_A1	OZ	GPMC Address 1 Output in A/D non-multiplexed mode and Address 17 in A/D multiplexed mode	AC35	N30
GPMC0_A2	OZ	GPMC Address 2 Output in A/D non-multiplexed mode and Address 18 in A/D multiplexed mode	AG35	T33
GPMC0_A3	OZ	GPMC Address 3 Output in A/D non-multiplexed mode and Address 19 in A/D multiplexed mode	AH36	L32
GPMC0_A4	OZ	GPMC Address 4 Output in A/D non-multiplexed mode and Address 20 in A/D multiplexed mode	AF35	P30
GPMC0_A5	OZ	GPMC Address 5 Output in A/D non-multiplexed mode and Address 21 in A/D multiplexed mode	AD34	M32
GPMC0_A6	OZ	GPMC Address 6 Output in A/D non-multiplexed mode and Address 22 in A/D multiplexed mode	AJ36	L33
GPMC0_A7	OZ	GPMC Address 7 Output in A/D non-multiplexed mode and Address 23 in A/D multiplexed mode	AF34	U31
GPMC0_A8	OZ	GPMC Address 8 Output in A/D non-multiplexed mode and Address 24 in A/D multiplexed mode	AE34	M33

Table 5-105. GPMC0 Signal Descriptions (continued)

SIGNAL NAME [1]	PIN TYPE [2]	DESCRIPTION [3]	ALY PIN [4]	AND PIN [4]
GPMC0_A9	OZ	GPMC Address 9 Output in A/D non-multiplexed mode and Address 25 in A/D multiplexed mode	AL33	P31
GPMC0_A10	OZ	GPMC Address 10 Output in A/D non-multiplexed mode and Address 26 in A/D multiplexed mode	AL34	N31
GPMC0_A11	OZ	GPMC Address 11 Output in A/D non-multiplexed mode and unused in A/D multiplexed mode	AC34	U32
GPMC0_A12	OZ	GPMC Address 12 Output in A/D non-multiplexed mode and unused in A/D multiplexed mode	AD33	N32
GPMC0_A13	OZ	GPMC Address 13 Output in A/D non-multiplexed mode and unused in A/D multiplexed mode	AD38	H29
GPMC0_A14	OZ	GPMC Address 14 Output in A/D non-multiplexed mode and unused in A/D multiplexed mode	AE35, AL32	M31, P32
GPMC0_A15	OZ	GPMC Address 15 Output in A/D non-multiplexed mode and unused in A/D multiplexed mode	AE33	U30
GPMC0_A16	OZ	GPMC Address 16 Output in A/D non-multiplexed mode and unused in A/D multiplexed mode	AH34	G30
GPMC0_A17	OZ	GPMC Address 17 Output in A/D non-multiplexed mode and unused in A/D multiplexed mode	AJ35	R31
GPMC0_A18	OZ	GPMC Address 18 Output in A/D non-multiplexed mode and unused in A/D multiplexed mode	AG34	R29
GPMC0_A19	OZ	GPMC Address 19 Output in A/D non-multiplexed mode and unused in A/D multiplexed mode	AK36	R30
GPMC0_A20	OZ	GPMC Address 20 Output in A/D non-multiplexed mode and unused in A/D multiplexed mode	AG33	R33
GPMC0_A21	OZ	GPMC Address 21 Output in A/D non-multiplexed mode and unused in A/D multiplexed mode	AH33	T32
GPMC0_A22	OZ	GPMC Address 22 Output in A/D non-multiplexed mode and unused in A/D multiplexed mode	AF33	T31
GPMC0_A23	OZ	GPMC Address 23 Output in A/D non-multiplexed mode and unused in A/D multiplexed mode	AJ33	T29
GPMC0_A24	OZ	GPMC Address 24 Output in A/D non-multiplexed mode and unused in A/D multiplexed mode	AG36	P29
GPMC0_AD0	IO	GPMC Data 0 Input/Output in A/D non-multiplexed mode and additionally Address 1 Output in A/D multiplexed mode	AK35	J30
GPMC0_AD1	IO	GPMC Data 1 Input/Output in A/D non-multiplexed mode and additionally Address 2 Output in A/D multiplexed mode	AK38	K31
GPMC0_AD2	IO	GPMC Data 2 Input/Output in A/D non-multiplexed mode and additionally Address 3 Output in A/D multiplexed mode	AF37	F32

Table 5-105. GPMC0 Signal Descriptions (continued)

SIGNAL NAME [1]	PIN TYPE [2]	DESCRIPTION [3]	ALY PIN [4]	AND PIN [4]
GPMC0_AD3	IO	GPMC Data 3 Input/Output in A/D non-multiplexed mode and additionally Address 4 Output in A/D multiplexed mode	AG37	H32
GPMC0_AD4	IO	GPMC Data 4 Input/Output in A/D non-multiplexed mode and additionally Address 5 Output in A/D multiplexed mode	AK37	E33
GPMC0_AD5	IO	GPMC Data 5 Input/Output in A/D non-multiplexed mode and additionally Address 6 Output in A/D multiplexed mode	AD36	L31
GPMC0_AD6	IO	GPMC Data 6 Input/Output in A/D non-multiplexed mode and additionally Address 7 Output in A/D multiplexed mode	AJ32	J33
GPMC0_AD7	IO	GPMC Data 7 Input/Output in A/D non-multiplexed mode and additionally Address 8 Output in A/D multiplexed mode	AJ37	G33
GPMC0_AD8	IO	GPMC Data 8 Input/Output in A/D non-multiplexed mode and additionally Address 9 Output in A/D multiplexed mode	AC32	G31
GPMC0_AD9	IO	GPMC Data 9 Input/Output in A/D non-multiplexed mode and additionally Address 10 Output in A/D multiplexed mode	AC37	J31
GPMC0_AD10	IO	GPMC Data 10 Input/Output in A/D non-multiplexed mode and additionally Address 11 Output in A/D multiplexed mode	AD37	P33
GPMC0_AD11	IO	GPMC Data 11 Input/Output in A/D non-multiplexed mode and additionally Address 12 Output in A/D multiplexed mode	AE37	G32
GPMC0_AD12	IO	GPMC Data 12 Input/Output in A/D non-multiplexed mode and additionally Address 13 Output in A/D multiplexed mode	AC36	K32
GPMC0_AD13	IO	GPMC Data 13 Input/Output in A/D non-multiplexed mode and additionally Address 14 Output in A/D multiplexed mode	AE36	R32
GPMC0_AD14	IO	GPMC Data 14 Input/Output in A/D non-multiplexed mode and additionally Address 15 Output in A/D multiplexed mode	AF38	N33
GPMC0_AD15	IO	GPMC Data 15 Input/Output in A/D non-multiplexed mode and additionally Address 16 Output in A/D multiplexed mode	AE38	G29
GPMC0_BE0n_CLE	O	GPMC Lower-Byte Enable (active low) or Command Latch Enable	AH38	H31
GPMC0_BE1n	O	GPMC Upper-Byte Enable (active low)	AJ38	F31
GPMC0_CSn0	O	GPMC Chip Select 0 (active low)	AG38	H30
GPMC0_CSn1	O	GPMC Chip Select 1 (active low)	AH37	F33
GPMC0_CSn2	O	GPMC Chip Select 2 (active low)	AE35, AL32	M31, P32
GPMC0_CSn3	O	GPMC Chip Select 3 (active low)	AJ33	T29
GPMC0_WAIT0	I	GPMC External Indication of Wait	AC33	G28
GPMC0_WAIT1	I	GPMC External Indication of Wait	AE33	U30
GPMC0_WAIT2	I	GPMC External Indication of Wait	AF33	T31
GPMC0_WAIT3	I	GPMC External Indication of Wait	AD38	H29

5.3.27 MMC

5.3.27.1 MAIN Domain

Table 5-106. MMC0 Signal Descriptions

SIGNAL NAME [1]	PIN TYPE [2]	DESCRIPTION [3]	ALY PIN [4]	AND PIN [4]
MMC0_CALPAD ⁽¹⁾	A	MMC/SD/SDIO Calibration Resistor	AJ7	AH2
MMC0_CLK	O	MMC/SD/SDIO Clock	AK5	AJ2
MMC0_CMD	IO	MMC/SD/SDIO Command	AL8	AL2
MMC0_DS	IO	MMC Data Strobe	AK4	AJ1
MMC0_DAT0	IO	MMC/SD/SDIO Data	AK9	AM1
MMC0_DAT1	IO	MMC/SD/SDIO Data	AL6	AK3
MMC0_DAT2	IO	MMC/SD/SDIO Data	AK8	AL1
MMC0_DAT3	IO	MMC/SD/SDIO Data	AK6	AK1
MMC0_DAT4	IO	MMC/SD/SDIO Data	AK7	AJ3
MMC0_DAT5	IO	MMC/SD/SDIO Data	AL7	AH3
MMC0_DAT6	IO	MMC/SD/SDIO Data	AL5	AJ4
MMC0_DAT7	IO	MMC/SD/SDIO Data	AK3	AK2

(1) An external 10 kΩ ±1% resistor must be connected between this pin and VSS. No external voltage should be applied to this pin.

Table 5-107. MMC1 Signal Descriptions

SIGNAL NAME [1]	PIN TYPE [2]	DESCRIPTION [3]	ALY PIN [4]	AND PIN [4]
MMC1_CLK ⁽²⁾	IO	MMC/SD/SDIO Clock	AB38	D33
MMC1_CMD	IO	MMC/SD/SDIO Command	AB36	E32
MMC1_SDCD ⁽¹⁾	I	SD Card Detect	AR38	AA32
MMC1_SDWP	I	SD Write Protect	AN37	W30
MMC1_DAT0	IO	MMC/SD/SDIO Data	AA33	F28
MMC1_DAT1	IO	MMC/SD/SDIO Data	AB34	F29
MMC1_DAT2	IO	MMC/SD/SDIO Data	AA32	E30
MMC1_DAT3	IO	MMC/SD/SDIO Data	AC38	F30

- (1) For ROM boot from MMC1 interface to work properly, the MMC1_SDCD pin should be pulled low externally with a resistor to indicate an SD Card/Memory device is present.
- (2) For MMC1_CLK signal to work properly, the RXACTIVE bit of the CTRLMMR_PADCONFIG171 register should be set to 0x1 because of retiming purposes.

5.3.28 OSPI

5.3.28.1 MCU Domain

Table 5-108. MCU_OSPI0 Signal Descriptions

SIGNAL NAME [1]	PIN TYPE [2]	DESCRIPTION [3]	ALY PIN [4]	AND PIN [4]
MCU_OSPI0_CLK	O	OSPI Clock	E32	D8
MCU_OSPI0_DQS	I	OSPI Data Strobe (DQS) or Loopback Clock Input	C34	C10
MCU_OSPI0_ECC_FAIL	I	OSPI ECC Status	C32, F31	B9, E11
MCU_OSPI0_LBCLKO	IO	OSPI Loopback Clock Output	D32	D10
MCU_OSPI0_CSn0	O	OSPI Chip Select 0 (active low)	A32	F12
MCU_OSPI0_CSn1	O	OSPI Chip Select 1 (active low)	A33	F11
MCU_OSPI0_CSn2	O	OSPI Chip Select 2 (active low)	B34, C31	B10, F10
MCU_OSPI0_CSn3	O	OSPI Chip Select 3 (active low)	C32, F31	B9, E11
MCU_OSPI0_D0	IO	OSPI Data 0	B33	E10
MCU_OSPI0_D1	IO	OSPI Data 1	B32	F9

Table 5-108. MCU_OSPI0 Signal Descriptions (continued)

SIGNAL NAME [1]	PIN TYPE [2]	DESCRIPTION [3]	ALY PIN [4]	AND PIN [4]
MCU_OSPI0_D2	IO	OSPI Data 2	C33	E9
MCU_OSPI0_D3	IO	OSPI Data 3	C35	D11
MCU_OSPI0_D4	IO	OSPI Data 4	D33	D9
MCU_OSPI0_D5	IO	OSPI Data 5	D34	C9
MCU_OSPI0_D6	IO	OSPI Data 6	E34	C7
MCU_OSPI0_D7	IO	OSPI Data 7	E33	C8
MCU_OSPI0_RESET_OUT0	O	OSPI Reset	B34, C31	B10, F10
MCU_OSPI0_RESET_OUT1	O	OSPI Reset	C32, G33	A9, E11

Table 5-109. MCU_OSPI1 Signal Descriptions

SIGNAL NAME [1]	PIN TYPE [2]	DESCRIPTION [3]	ALY PIN [4]	AND PIN [4]
MCU_OSPI1_CLK	O	OSPI Clock	F32	B7
MCU_OSPI1_DQS	I	OSPI Data Strobe (DQS) or Loopback Clock Input	F31	B9
MCU_OSPI1_LBCLKO	IO	OSPI Loopback Clock Output	C31	B10
MCU_OSPI1_CSn0	O	OSPI Chip Select 0 (active low)	G32	A8
MCU_OSPI1_CSn1	O	OSPI Chip Select 1 (active low)	G33	A9
MCU_OSPI1_D0	IO	OSPI Data 0	E35	B8
MCU_OSPI1_D1	IO	OSPI Data 1	D31	B11
MCU_OSPI1_D2	IO	OSPI Data 2	G31	A11
MCU_OSPI1_D3	IO	OSPI Data 3	F33	A10

5.3.29 Hyperbus

5.3.29.1 MCU Domain

Table 5-110. MCU_HYPERBUS0 Signal Descriptions

SIGNAL NAME [1]	PIN TYPE [2]	DESCRIPTION [3]	ALY PIN [4]	AND PIN [4]
MCU_HYPERBUS0_CK	O	Hyperbus Differential Clock (positive)	E32	D8
MCU_HYPERBUS0_CKn	O	Hyperbus Differential Clock (negative)	D32	D10
MCU_HYPERBUS0_INTn	I	Hyperbus Interrupt (active low)	C32, F31	B9, E11
MCU_HYPERBUS0_RESETn	O	Hyperbus Reset (active low) Output	A33	F11
MCU_HYPERBUS0_RESETOn	I	Hyperbus Reset Status Indicator (active low) from Hyperbus Memory	B34, C31	B10, F10
MCU_HYPERBUS0_RWDS	IO	Hyperbus Read-Write Data Strobe	C34	C10
MCU_HYPERBUS0_WPn	O	Hyperbus Write Protect (Not in use)	B34, C32, G33	A9, E11, F10
MCU_HYPERBUS0_CSn0	O	Hyperbus Chip Select 0	A32	F12
MCU_HYPERBUS0_CSn1	O	Hyperbus Chip Select 1	B34, G33	A9, F10
MCU_HYPERBUS0_DQ0	IO	Hyperbus Data 0	B33	E10
MCU_HYPERBUS0_DQ1	IO	Hyperbus Data 1	B32	F9
MCU_HYPERBUS0_DQ2	IO	Hyperbus Data 2	C33	E9
MCU_HYPERBUS0_DQ3	IO	Hyperbus Data 3	C35	D11
MCU_HYPERBUS0_DQ4	IO	Hyperbus Data 4	D33	D9
MCU_HYPERBUS0_DQ5	IO	Hyperbus Data 5	D34	C9
MCU_HYPERBUS0_DQ6	IO	Hyperbus Data 6	E34	C7
MCU_HYPERBUS0_DQ7	IO	Hyperbus Data 7	E33	C8

5.3.30 Emulation and Debug

5.3.30.1 MAIN Domain

Table 5-111. JTAG Signal Descriptions

SIGNAL NAME [1]	PIN TYPE [2]	DESCRIPTION [3]	ALY PIN [4]	AND PIN [4]
EMU0	IO	Emulation Control 0	F35	F19
EMU1	IO	Emulation Control 1	H34	E17
TCK	I	JTAG Test Clock Input	G35	F21
TDI	I	JTAG Test Data Input	AL37	V33
TDO	OZ	JTAG Test Data Output	AL35	W33
TMS	I	JTAG Test Mode Select Input	AL36	V32
TRSTn	I	JTAG Reset	G37	F17

Table 5-112. Trace Signal Descriptions

SIGNAL NAME [1]	PIN TYPE [2]	DESCRIPTION [3]	ALY PIN [4]	AND PIN [4]
TRC_CLK	O	Trace Clock	AG36, AJ32	J33, P29
TRC_CTL	O	Trace Control	AJ33, AJ37	G33, T29
TRC_DATA0	O	Trace Data 0	AF33, AJ34	T30, T31
TRC_DATA1	O	Trace Data 1	AD36, AH33	L31, T32
TRC_DATA2	O	Trace Data 2	AG33, AK37	E33, R33
TRC_DATA3	O	Trace Data 3	AC33, AK36	G28, R30
TRC_DATA4	O	Trace Data 4	AD37	P33
TRC_DATA5	O	Trace Data 5	AH38	H31
TRC_DATA6	O	Trace Data 6	AC37	J31
TRC_DATA7	O	Trace Data 7	AJ38	F31
TRC_DATA8	O	Trace Data 8	AC32	G31
TRC_DATA9	O	Trace Data 9	AE37	G32
TRC_DATA10	O	Trace Data 10	AK33	H33
TRC_DATA11	O	Trace Data 11	AF38	N33
TRC_DATA12	O	Trace Data 12	AG37	H32
TRC_DATA13	O	Trace Data 13	AE36	R32
TRC_DATA14	O	Trace Data 14	AF37	F32
TRC_DATA15	O	Trace Data 15	AC36	K32
TRC_DATA16	O	Trace Data 16	AE38	G29
TRC_DATA17	O	Trace Data 17	AH37	F33
TRC_DATA18	O	Trace Data 18	AK34	J32
TRC_DATA19	O	Trace Data 19	AG38	H30
TRC_DATA20	O	Trace Data 20	AF36	K33
TRC_DATA21	O	Trace Data 21	AG34	R29
TRC_DATA22	O	Trace Data 22	AJ35	R31
TRC_DATA23	O	Trace Data 23	AH34	G30
TRC_DATA24	O	Trace Data 24	AE33	U30
TRC_DATA25	O	Trace Data 25	AL32	P32

5.3.31 System and Miscellaneous

5.3.31.1 Boot Mode configuration

Table 5-113. Sysboot Signal Descriptions

SIGNAL NAME [1]	PIN TYPE [2]	DESCRIPTION [3]	ALY PIN [4]	AND PIN [4]
BOOTMODE00	I	Bootmode Pin 0	B33	E10
BOOTMODE01	I	Bootmode Pin 1	B32	F9
BOOTMODE02	I	Bootmode Pin 2	D33	D9
BOOTMODE03	I	Bootmode Pin 3	D34	C9
BOOTMODE04	I	Bootmode Pin 4	M37	A19
BOOTMODE05	I	Bootmode Pin 5	M36	B20
BOOTMODE06	I	Bootmode Pin 6	N34	A17
BOOTMODE07	I	Bootmode Pin 7	M34	A18
MCU_BOOTMODE00	I	MCU Bootmode Pin 0	G38	F15
MCU_BOOTMODE01	I	MCU Bootmode Pin 1	H36	E18
MCU_BOOTMODE02	I	MCU Bootmode Pin 2	J38	E14
MCU_BOOTMODE03	I	MCU Bootmode Pin 3	H38	E15
MCU_BOOTMODE04	I	MCU Bootmode Pin 4	J34	D16
MCU_BOOTMODE05	I	MCU Bootmode Pin 5	J35	D18
MCU_BOOTMODE06	I	MCU Bootmode Pin 6	H37	D15
MCU_BOOTMODE07	I	MCU Bootmode Pin 7	K37	C16
MCU_BOOTMODE08	I	MCU Bootmode Pin 8	J37	D17
MCU_BOOTMODE09	I	MCU Bootmode Pin 9	K38	D21

5.3.31.2 Clock

Table 5-114. Clock0 Signal Descriptions

SIGNAL NAME [1]	PIN TYPE [2]	DESCRIPTION [3]	ALY PIN [4]	AND PIN [4]
WKUP_LF_CLKIN	I	Low Frequency (32.768 KHz) Oscillator Input	M34	A18
WKUP_OSC0_XI	I	High Frequency Oscillator Input	T38	A24
WKUP_OSC0_XO	O	High Frequency Oscillator Output	U37	B25

Table 5-115. Clock1 Signal Descriptions

SIGNAL NAME [1]	PIN TYPE [2]	DESCRIPTION [3]	ALY PIN [4]	AND PIN [4]
OSC1_XI	I	High Frequency Oscillator Input	P38	B23
OSC1_XO	O	High Frequency Oscillator Output	N37	A22

5.3.31.3 System

Table 5-116. MCU System Signal Descriptions

SIGNAL NAME [1]	PIN TYPE [2]	DESCRIPTION [3]	ALY PIN [4]	AND PIN [4]
MCU_CLKOUT0	OZ	Reference clock output for Ethernet PHYs (50MHz or 25MHz)	M38	B21
MCU_EXT_REFCLK0	I	External system clock input	L33, M33	A20, B18
MCU_OBSCLK0	O	Observation clock output for test and debug purposes only	H34, M38	B21, E17
MCU_PORz	I	MCU Domain Cold Reset	K32	C24
MCU_RESETSTATz	O	MCU Domain Warm Reset status output	F36	E21
MCU_RESETz	I	MCU Domain Warm Reset	G36	E20
MCU_SAFETY_ERRORn	IO	Error signal output from MCU Domain ESM	N36	C22

Table 5-116. MCU System Signal Descriptions (continued)

SIGNAL NAME [1]	PIN TYPE [2]	DESCRIPTION [3]	ALY PIN [4]	AND PIN [4]
MCU_SYSCCLKOUT0	O	MCU Domain system clock output for test and debug purposes only	L33	B18

Table 5-117. System Signal Descriptions

SIGNAL NAME [1]	PIN TYPE [2]	DESCRIPTION [3]	ALY PIN [4]	AND PIN [4]
AUDIO_EXT_REFCLK0	IO	External clock routed to ATL or McASP as one of the selectable input clock sources, or as a output clock output for ATL or McASP	AJ34	T30
AUDIO_EXT_REFCLK1	IO	External clock routed to ATL or McASP as one of the selectable input clock sources, or as a output clock output for ATL or McASP	AH37	F33
EXTINTn	I	External Interrupt	AN35	Y29
EXT_REFCLK1	I	External clock input to Main Domain, routed to Timer clock muxes as one of the selectable input clock sources for Timer/WDT modules, or as reference clock to MAIN_PLL2 (PER1 PLL)	AJ32	J33
GPMC0_FCLK_MUX	O	GPMC functional clock output selected through a mux logic	AF36	K33
OBSCLK0	O	Observation clock output for test and debug purposes only	AN37	W30
OBSCLK1	O	Observation clock output for test and debug purposes only	AG37	H32
PMIC_POWER_EN1	O	Power enable output for MAIN Domain supplies	L38	B16
PMIC_WAKE0n	O	PMIC WakeUp	AJ34	T30
PMIC_WAKE1n	O	PMIC WakeUp	M33	A20
PORz	I	SoC PORz Reset Signal	P33	D24
RESETSTATz	O	Main Domain Warm Reset status output	AL38	W32
RESET_REQz	I	Main Domain external Warm Reset request input	F34	G20
SOC_SAFETY_ERRORn	IO	Error signal output from Main Domain ESM	AM34	Y31
SYNC0_OUT	O	CPTS Time Stamp Generator Bit 0	AD36	L31
SYNC1_OUT	O	CPTS Time Stamp Generator Bit 1	AJ32	J33
SYNC2_OUT	O	CPTS Time Stamp Generator Bit 2	AD38	H29
SYNC3_OUT	O	CPTS Time Stamp Generator Bit 3	AD37	P33
SYSCCLKOUT0	O	SYSCCLK0 output from Main PLL controller (divided by 6) for test and debug purposes only	AR38	AA32

5.3.31.4 EFUSE

Table 5-118. EFUSE Signal Descriptions

SIGNAL NAME [1]	PIN TYPE [2]	DESCRIPTION [3]	ALY PIN [4]	AND PIN [4]
VPP_CORE	PWR	Programming Voltage for MAIN Domain Efuses	AA31	V29
VPP_MCU	PWR	Programming Voltage for MCU Domain Efuses	L29	F26

5.3.31.5 VMON

Table 5-119. VMON Signal Descriptions

SIGNAL NAME [1]	PIN TYPE [2]	DESCRIPTION [3]	ALY PIN [4]	AND PIN [4]
VMON1_ER_VSYS	A	Voltage Monitor, fixed 0.45V (+/-3%) threshold. Use with external precision voltage divider to monitor a higher voltage rail such as the PMIC input supply.	K28	G26
VMON2_IR_VCPU	A	Must be externally connected directly to VDD_CPU	N27	L25
VMON3_IR_VEXT1P8	A	General purpose voltage monitor for external supplies, 1.8V threshold. With internal resistor divider.	J30	K30
VMON4_IR_VEXT1P8	A	General purpose voltage monitor for external supplies, 1.8V threshold. With internal resistor divider.	P28	M26
VMON5_IR_VEXT3P3	A	General purpose voltage monitor for external supplies, 3.3V threshold. With internal resistor divider.	R29	M29

5.3.32 Power

Table 5-120. Power Supply Signal Descriptions

SIGNAL NAME [1]	PIN TYPE [2]	DESCRIPTION [3]	ALY PIN [4]	AND PIN [4]
CAP_VDDSD0 ⁽¹⁾	CAP	External Capacitor Connection	V29	T27
CAP_VDDSD0_MCU ⁽¹⁾	CAP	External Capacitor Connection	L27	J25
CAP_VDDSD1_MCU ⁽¹⁾	CAP	External Capacitor Connection	L25	J23
CAP_VDDSD2 ⁽¹⁾	CAP	External Capacitor Connection	T29	P27
CAP_VDDSD2_MCU ⁽¹⁾	CAP	External Capacitor Connection	L26	J24
CAP_VDDSD5 ⁽¹⁾	CAP	External Capacitor Connection	P29	M27
VDDAR_CORE	PWR	Core RAM Supply	AB27, AC24, AF15, AF18, AF21, AG11, AG28, T25	AA22, AD13, AD16, AD19, AE26, AE9, P23, Y25
VDDAR_CPU	PWR	CPU RAM Supply	AB13, AC16, AC18, AC20, AE12, M21, N23, T15, U20, W14, W21, Y11, Y19	AA14, AA16, AA18, AC10, K19, L21, P13, R18, U12, U19, V17, V9, Y11
VDDAR_MCU	PWR	MCU RAM Supply	M27, N24	K25, L22
VDDA_0P8_DSITX	PWR	Analog Supply for DSITX	AJ24	AG22
VDDA_0P8_DSITX_C	PWR	DSITX Clock Supply	AJ25	AG23
VDDA_0P8_UFS	PWR	UFS 0.8V Supply	AH11	AF9
VDDA_0P8_USB	PWR	USB 0.8V Supply	AK20	AG17
VDDA_0P8_CSIRX2	PWR	Analog Supply for CSIRX	AJ28	AG26
VDDA_0P8_CSIRX0_1	PWR	Analog Supply for CSIRX	AJ26, AK26	AG24
VDDA_0P8_DLL_MMC0	PWR	MMC DLL Analog Supply	AE9	AD7
VDDA_0P8_PLL_DDR0	PWR	DDR de-skew PLL Analog Supply	U11	P8
VDDA_0P8_PLL_DDR1	PWR	DDR de-skew PLL Analog Supply	M14	J11
VDDA_0P8_PLL_DDR2	PWR	DDR de-skew PLL Analog Supply	N11	
VDDA_0P8_PLL_DDR3	PWR	DDR de-skew PLL Analog Supply	M18	
VDDA_0P8_SERDES2	PWR	SERDES 0.8V Supply	AJ20, AJ21	
VDDA_0P8_SERDES4	PWR	SERDES 0.8V Supply	AJ17, AJ18	AG15, AG16
VDDA_0P8_SERDES0_1	PWR	SERDES 0.8V Supply	AJ12, AJ15, AK13, AK14	AF12, AG10, AG13
VDDA_0P8_SERDES_C2	PWR	SERDES 0.8V Clock Supply	AG21, AH20	

Table 5-120. Power Supply Signal Descriptions (continued)

SIGNAL NAME [1]	PIN TYPE [2]	DESCRIPTION [3]	ALY PIN [4]	AND PIN [4]
VDDA_0P8_SERDES_C4	PWR	SERDES 0.8V Clock Supply	AG17, AH18	AE15, AF16
VDDA_0P8_SERDES_C0_1	PWR	SERDES 0.8V Clock Supply	AH12, AH13, AH15, AH16	AF10, AF13
VDDA_1P8_DSITX	PWR	Analog Supply for DSITX	AH24, AH25	AF22, AF23
VDDA_1P8_UFS	PWR	UFS 1.8V Supply	AJ10	AG8
VDDA_1P8_USB	PWR	USB 1.8V Supply	AK21	AH19
VDDA_1P8_CSIRX2	PWR	Analog Supply for CSIRX	AH29, AJ29	AF27, AG27
VDDA_1P8_CSIRX0_1	PWR	Analog Supply for CSIRX	AH27, AH28	AF25, AF26
VDDA_1P8_SERDES2	PWR	SERDES 1.8V Supply	AH21	
VDDA_1P8_SERDES4	PWR	SERDES 1.8V Supply	AH17	AF15
VDDA_1P8_SERDES0_1	PWR	SERDES 1.8V Supply	AJ13, AJ14	AG11, AG12
VDDA_1P8_SERDES2_4	PWR	SERDES 1.8V Supply	AJ23	AG21
VDDA_3P3_USB	PWR	USB 3.3V Supply	AJ19	AF17
VDDA_ADC0	PWR	ADC0 Analog Supply	M31	J28
VDDA_ADC1	PWR	ADC1 Analog Supply	N30	K28
VDDA_MCU_PLLGRP0	PWR	Analog Supply for MCU PLL Group 0	M28	K26
VDDA_MCU_TEMP	PWR	Analog Supply for MCU temperature sensor	M26	K24
VDDA_OSC1	PWR	HFOSC1 Supply	N29	L27
VDDA_PLLGRP0	PWR	Analog Supply for MAIN PLL Group 0	AA27	W25
VDDA_PLLGRP1	PWR	Analog Supply for MAIN PLL Group 1	Y28	V25
VDDA_PLLGRP2	PWR	Analog Supply for MAIN PLL Group 2	AG13	AE11
VDDA_PLLGRP5	PWR	Analog Supply for MAIN PLL Group 5	V14	T12
VDDA_PLLGRP6	PWR	Analog Supply for MAIN PLL Group 6	R21	N19
VDDA_PLLGRP7	PWR	Analog Supply for MAIN PLL Group 7	P12	M10
VDDA_PLLGRP8	PWR	Analog Supply for MAIN PLL Group 8	P15	K13
VDDA_PLLGRP9	PWR	Analog Supply for MAIN PLL Group 9	Y26	V24
VDDA_PLLGRP10	PWR	Analog Supply for MAIN PLL Group 10	AG23	AD20
VDDA_PLLGRP12	PWR	Analog Supply for MAIN PLL Group 12	AA23	W21
VDDA_PLLGRP13	PWR	Analog Supply for MAIN PLL Group 13	AB26	Y24
VDDA_POR_WKUP	PWR	WKUP domain Analog Supply	N28	L26
VDDA_TEMP0	PWR	Analog Supply for temperature sensor 0	Y27	V26
VDDA_TEMP1	PWR	Analog Supply for temperature sensor 1	M12	K10
VDDA_TEMP2	PWR	Analog Supply for temperature sensor 2	W23	U21
VDDA_TEMP3	PWR	Analog Supply for temperature sensor 3	AE13	AC11
VDDA_TEMP4	PWR	Analog Supply for temperature sensor 4	AD18	AB16
VDDA_WKUP	PWR	Oscillator Supply for WKUP domain	K31, L32	J27
VDDSHV0	PWR	IO Power Supply	V30, V32, W31	T28
VDDSHV0_MCU	PWR	IO Power Supply	H29, J28, K29	H27
VDDSHV1_MCU	PWR	IO Power Supply	H25, J24, K25	G22, H23
VDDSHV2	PWR	IO Power Supply	T30, T32, U31	N28, P28
VDDSHV2_MCU	PWR	IO Power Supply	H27, J26, K27	G24, H25
VDDSHV5	PWR	IO Power Supply	P31, R30, R31	N27

Table 5-120. Power Supply Signal Descriptions (continued)

SIGNAL NAME [1]	PIN TYPE [2]	DESCRIPTION [3]	ALY PIN [4]	AND PIN [4]
VDDS_DDR	PWR	DDR PHY IO Supply	A31, AK1, B1, H11, H13, H15, H17, H19, H9, J10, J12, J14, J16, J18, J8, K11, K13, K15, K17, K19, K9, L10, L12, L14, L16, L18, M9, N10, N8, P9, R10, R8, T9, U10, U8	A2, AH1, G10, G12, G14, G16, G18, H11, H13, H15, H17, H9, J10, J14, J16, J8, K7, L8, M7, P7, R8
VDDS_DDR_C0	PWR	IO Power Supply for DDR Clock	T10	N8
VDDS_DDR_C1	PWR	IO Power Supply for DDR Clock	L15	J12
VDDS_DDR_C2	PWR	IO Power Supply for DDR Clock	M10	
VDDS_DDR_C3	PWR	IO Power Supply for DDR Clock	L17	
VDDS_MMC0	PWR	MMC0 PHY IO Supply	AF9, AG10, AG8, AH9	AE8, AF7
VDD_CORE	PWR	MAIN domain core Supply	AA24, AA26, AA28, AA30, AB25, AB29, AB31, AC26, AC28, AC30, AD25, AD27, AD29, AD31, AE24, AE26, AE28, AE30, AE32, AF13, AF17, AF19, AF23, AF25, AF27, AF29, AF31, AG12, AG14, AG16, AG18, AG20, AG22, AG24, AG26, AG30, AG32, AH31, AJ30, M11, M13, M15, M17, M19, N12, N16, N18, P11, P17, P19, R12, R14, R16, R18, R24, R26, R28, T11, T13, T27, U12, U24, U26, U28, V25, V27, W24, W26, W28, W30, W32, Y25, Y29, Y31	AA24, AA26, AA28, AB23, AB25, AB27, AC22, AC24, AC26, AC28, AD11, AD15, AD17, AD21, AD23, AD25, AD27, AE10, AE12, AE14, AE16, AE18, AE20, AE22, AE24, AE28, AF19, K11, K15, K17, K9, L10, L12, L14, L16, M11, M13, M15, M17, M9, N10, N12, N14, N16, N22, N24, N26, P11, P25, P9, R10, R22, R24, R26, T23, T25, U22, U24, U26, U28, V23, V27, W22, W24, W26, W28, Y23, Y27
VDD_CPU	PWR	CPU core Supply	AA10, AA12, AA14, AA20, AA22, AA8, AB11, AB19, AB21, AB23, AB9, AC10, AC12, AC14, AC22, AD11, AD13, AD15, AD17, AD19, AD21, AD23, AD9, AE10, AE14, AE16, AE18, AE20, AE22, AF11, H21, H23, J20, J22, K21, K23, L20, L22, N20, N22, P21, R20, R22, T17, T19, T21, T23, U14, U22, V11, V13, V19, V21, V23, V9, W10, W12, W20, W22, W8, Y13, Y21, Y23, Y9	AA10, AA12, AA20, AA8, AB11, AB13, AB15, AB17, AB19, AB21, AB9, AC12, AC14, AC16, AC18, AC20, AC8, AD9, H19, H21, J18, J20, L18, L20, M19, N18, N20, P15, P17, P19, P21, R12, R20, T11, T17, T19, T21, T9, U10, U18, U20, U8, V11, V19, V21, W10, W12, W18, W20, W8, Y17, Y19, Y21, Y9
VDD_MCU	PWR	MCU core Supply	L24, M23, M25, N26, P23, P25, P27	J22, K21, K23, L24, M21, M23, M25
VDD_MCU_WAKE1	PWR	Core Supply for MCU daisy chain	L28	J26
VDD_WAKE0	PWR	Core Supply for MAIN domain daisy chain	U29	R27

Table 5-120. Power Supply Signal Descriptions (continued)

SIGNAL NAME [1]	PIN TYPE [2]	DESCRIPTION [3]	ALY PIN [4]	AND PIN [4]
VSS	GND	Ground	A1, A10, A12, A15, A2, A20, A23, A25, A28, A34, A37, A5, A7, AA11, AA13, AA19, AA2, AA21, AA25, AA29, AA34, AA36, AA38, AA5, AA9, AB1, AB10, AB12, AB14, AB20, AB22, AB24, AB28, AB30, AB32, AB33, AB35, AB37, AB5, AB8, AC11, AC13, AC15, AC17, AC19, AC2, AC21, AC23, AC25, AC27, AC29, AC31, AC6, AC9, AD1, AD10, AD12, AD14, AD16, AD20, AD22, AD24, AD26, AD28, AD30, AD32, AD35, AD4, AD8, AE11, AE15, AE17, AE19, AE2, AE21, AE23, AE25, AE27, AE29, AE31, AE5, AF10, AF12, AF14, AF16, AF20, AF22, AF24, AF26, AF28, AF3, AF30, AF32, AF6, AF8, AG1, AG15, AG19, AG25, AG27, AG29, AG31, AG4, AG7, AG9, AH10, AH14, AH19, AH2, AH22, AH23, AH26, AH30, AH32, AH35, AH5, AH8, AJ11, AJ16, AJ22, AJ27, AJ3, AJ31, AJ6, AJ8, AJ9, AK10, AK11, AK12, AK15, AK16, AK17, AK18, AK19, AK22, AK23, AK24, AK25, AK27, AK28, AK30, AK32, AL1, AL10, AL12, AL13, AL14, AL15, AL16, AL17, AL18, AL19, AL21, AL26, AL29, AL31, AL4, AM11, AM13, AM15, AM18, AM20, AM23, AM25, AM27, AM3, AM30, AM32, AM38, AM6, AN1, AN10, AN12, AN14, AN16, AN19, AN22, AN25, AN28, AN31, AN34, AN4, AN7, AP12, AP15, AP18, AP21, AP24, AP27, AP3, AP30, AP33, AP36, AP6, AP9, AR1, AR10, AR13, AR16,	A1, A23, A25, A27, A29, A31, A4, A7, AA11, AA13, AA15, AA17, AA19, AA2, AA21, AA23, AA25, AA27, AA29, AA31, AA33, AA5, AA9, AB1, AB10, AB12, AB14, AB18, AB20, AB22, AB24, AB26, AB28, AB30, AB32, AB4, AB8, AC13, AC15, AC17, AC19, AC2, AC21, AC23, AC25, AC27, AC5, AC9, AD10, AD12, AD14, AD18, AD22, AD24, AD26, AD28, AD29, AD3, AD31, AD33, AD6, AD8, AE1, AE13, AE17, AE19, AE21, AE23, AE25, AE27, AE30, AE32, AE4, AE7, AF11, AF14, AF18, AF2, AF20, AF21, AF24, AF28, AF5, AF8, AG14, AG18, AG20, AG25, AG28, AG29, AG3, AG31, AG33, AG6, AG9, AH12, AH15, AH18, AH21, AH24, AH26, AH28, AH30, AH5, AJ11, AJ14, AJ17, AJ20, AJ23, AJ26, AJ29, AJ32, AJ6, AJ8, AK10, AK13, AK16, AK19, AK22, AK25, AK28, AK31, AK4, AK7, AL12, AL15, AL18, AL21, AL24, AL27, AL3, AL30, AL33, AL6, AL9, AM11, AM14, AM17, AM2, AM20, AM23, AM26, AM29, AM32, AM33, AM5, AM8, AN1, AN10, AN13, AN16, AN19, AN22, AN25, AN28, AN31, AN32, AN4, AN7, B22, B24, B26, B28, B3, B30, B32, B6, C11, C13, C15, C17, C2, C21, C23, C25, C27, C29, C31, C33, C5, D1, D26, D28, D30, D32, D4, D7, E23, E25, E27, E29, E3, E31, E6, E8, F14, F16, F18, F2, F20, F22, F24, F5, F7, G1, G11, G13, G15, G17, G19, G21,

Table 5-120. Power Supply Signal Descriptions (continued)

SIGNAL NAME [1]	PIN TYPE [2]	DESCRIPTION [3]	ALY PIN [4]	AND PIN [4]
			AR19, AR22, AR25, AR28, AR31, AR34, AR37, AR4, AR7, AT12, AT15, AT18, AT21, AT24, AT27, AT3, AT30, AT33, AT36, AT6, AT9, AU1, AU10, AU13, AU16, AU19, AU22, AU25, AU28, AU31, AU34, AU37, AU38, AU4, AU7, AV1, AV11, AV14, AV17, AV2, AV20, AV23, AV26, AV29, AV32, AV35, AV5, AV8, B11, B13, B16, B19, B22, B24, B26, B29, B31, B38, B6, B9, C14, C17, C18, C2, C21, C27, C30, C4, C8, D10, D15, D20, D23, D28, D3, D35, D6, D7, E12, E13, E16, E19, E2, E22, E25, E26, E29, E31, E5, E9, F1, F11, F14, F17, F21, F24, F27, F30, F4, F7, F8, G15, G18, G20, G28, G3, G6, H10, H16, H18, H2, H20, H22, H24, H26, H28, H30, H31, H5, H7, H8, J1, J11, J13, J15, J17, J19, J21, J23, J25, J27, J29, J32, J4, J9, K10, K12, K14, K16, K18, K2, K20, K22, K24, K26, K6, K8, L1, L11, L13, L19, L21, L23, L31, L5, L9, M16, M2, M20, M22, M24, M29, M30, M32, M5, M8, N15, N17, N19, N21, N25, N3, N31, N32, N38, N6, N9, P1, P10, P16, P18, P20, P22, P24, P26, P30, P32, P35, P37, P4, P7, P8, R11, R13, R15, R17, R19, R2, R23, R25, R27, R32, R34, R36, R38, R5, R9, T12, T14, T16, T18, T20, T22, T24, T26, T28, T3, T31, T33, T35, T37, T6, T8, U13, U19, U21, U23, U25, U27, U3, U30, U32, U34, U36, U38, U6, U9, V10, V12, V2, V20, V22, V24, V26, V28, V31, V33,	G23, G25, G27, G4, G9, H10, H12, H14, H16, H18, H2, H20, H22, H24, H26, H28, H5, H8, J1, J13, J15, J17, J19, J21, J6, J7, J9, K12, K14, K16, K18, K2, K20, K22, K27, K29, K5, K8, L11, L13, L15, L17, L19, L23, L3, L6, L7, L9, M1, M12, M14, M16, M18, M20, M22, M24, M28, M4, M8, N11, N13, N15, N17, N2, N21, N23, N25, N29, N5, N7, N9, P10, P12, P14, P16, P18, P20, P22, P24, P26, P3, R11, R17, R19, R21, R23, R25, R28, R3, R6, R9, T10, T18, T2, T20, T22, T24, T26, T5, T8, U1, U11, U17, U23, U25, U27, U29, U33, U4, U7, U9, V10, V12, V18, V20, V22, V28, V3, V6, V8, W11, W17, W19, W2, W23, W27, W29, W5, W9, Y1, Y10, Y12, Y18, Y20, Y22, Y26, Y28, Y6, Y8

Table 5-120. Power Supply Signal Descriptions (continued)

SIGNAL NAME [1]	PIN TYPE [2]	DESCRIPTION [3]	ALY PIN [4]	AND PIN [4]
			V35, V37, V5, V8, W1, W11, W13, W19, W25, W27, W29, W34, W36, W38, W4, W7, W9, Y10, Y12, Y14, Y20, Y22, Y24, Y3, Y30, Y32, Y33, Y35, Y37, Y6, Y8	

(1) This pin must always be connected via a 1- μ F \pm 10% capacitor to VSS.

5.4 Pin Connectivity Requirements

This section describes connectivity requirements for package balls that have specific connectivity requirements and unused package balls.

Note

All power balls must be supplied with the voltages specified in the [Recommended Operating Conditions](#) section, unless otherwise specified in [Signal Descriptions](#).

Note

For additional clarification, "leave unconnected" or "no connect" (NC) means no signal traces can be connected to these device ball number.

[Table 5-121](#) shows the connectivity requirements for specific signals by ball name and ball number.

Table 5-121. Connectivity Requirements

ALY BALL NUMBER	AND BALL NUMBER	BALL NAME	CONNECTION REQUIREMENT	
P38	B23	OSC1_XI	Each of these balls must be connected to VSS through a separate external pull resistor to ensure these balls are held to a valid logic low-level, if unused.	
T38	A24	WKUP_OSC0_XI		
G37	F17	TRSTN		
U1	R1	DDR0_DQS0P		
AA1	V1	DDR0_DQS1P		
AF1	AD1	DDR0_DQS2P		
AJ1	AG1	DDR0_DQS3P		
A16	B1	DDR1_DQS0P		
A13	E1	DDR1_DQS1P		
A8	L1	DDR1_DQS2P		
A3	P1	DDR1_DQS3P		
T1	–	DDR2_DQS0P		
N1	–	DDR2_DQS1P		
H1	–	DDR2_DQS2P		
E1	–	DDR2_DQS3P		
A18	–	DDR3_DQS0P		
A21	–	DDR3_DQS1P		
A26	–	DDR3_DQS2P		
A29	–	DDR3_DQS3P		
AC8	AC7	DDR0_RET		
G8	G8	DDR1_RET		
L8	-	DDR2_RET		
G27	-	DDR3_RET		
K28	G26	VMON1_ER_VSYS		
N27	L25	VMON2_IR_VCPU		
J30	K30	VMON3_IR_VEXT1P8		
P28	M26	VMON4_IR_VEXT1P8		
R29	M29	VMON5_IR_VEXT3P3		
P36	E26	MCU_ADC0_AIN0		Each of these balls can be connected to VSS through a separate external pull resistor or can be connected directly to VSS to ensure these balls are held to a valid logic low-level, if unused.
V36	F25	MCU_ADC0_AIN1		
T34	F23	MCU_ADC0_AIN2		
T36	A28	MCU_ADC0_AIN3		
P34	E24	MCU_ADC0_AIN4		
R37	D27	MCU_ADC0_AIN5		
R33	A26	MCU_ADC0_AIN6		
V38	B27	MCU_ADC0_AIN7		
Y38	C32	MCU_ADC1_AIN0		
Y34	B33	MCU_ADC1_AIN1		
V34	B31	MCU_ADC1_AIN2		
W37	B29	MCU_ADC1_AIN3		
AA37	D31	MCU_ADC1_AIN4		
W33	A32	MCU_ADC1_AIN5		
U33	A30	MCU_ADC1_AIN6		
Y36	C28	MCU_ADC1_AIN7		

Table 5-121. Connectivity Requirements (continued)

ALY BALL NUMBER	AND BALL NUMBER	BALL NAME	CONNECTION REQUIREMENT
AN11	AG7	SERDES0_REXT	Each of these balls must be connected to VSS through appropriate external pull resistor to ensure these balls are held to a valid logic low level, if unused. Refer to Signal Descriptions footnote for appropriate value of pull-resistor for each signal.
AL9	AH9	SERDES1_REXT	
AL20	-	SERDES2_REXT	
AM19	AH23	SERDES4_REXT	
AM28	AH31	CSI0_RXRCALIB	
AL28	AJ33	CSI1_RXRCALIB	
AM31	AH29	CSI2_RXRCALIB	
AE8	R7	DDR0_CAL0	
G14	F8	DDR1_CAL0	
U7	-	DDR2_CAL0	
F18	-	DDR3_CAL0	
AM24	AH25	DSI0_TXRCALIB	
AL22	AH27	DSI1_TXRCALIB	
AN18	AH22	USB0_RCALIB	

Table 5-121. Connectivity Requirements (continued)

ALY BALL NUMBER	AND BALL NUMBER	BALL NAME	CONNECTION REQUIREMENT
G36	E20	MCU_RESETZ	Each of these balls must be connected to the corresponding power supply through a separate external pull resistor to ensure these balls are held to a valid logic high level, if unused.
K32	C24	MCU_PORZ	
P33	D24	PORZ	
F34	G20	RESET_REQZ	
G35	F21	TCK	
AL36	V32	TMS	
G34	A21	MCU_I2C0_SDA	
M35	D22	MCU_I2C0_SCL	
N33	A16	WKUP_I2C0_SCL	
N35	D23	WKUP_I2C0_SDA	
AN36	AA30	I2C0_SCL	
AP37	Y30	I2C0_SDA	
AN35	Y29	EXTINTN	
AL37	V33	TDI	
AL35	W33	TDO	
F35	F19	EMU0	
H34	E17	EMU1	
V1	T1	DDR0_DQS0N	
Y1	W1	DDR0_DQS1N	
AE1	AC1	DDR0_DQS2N	
AH1	AF1	DDR0_DQS3N	
A17	C1	DDR1_DQS0N	
A14	F1	DDR1_DQS1N	
A9	K1	DDR1_DQS2N	
A4	N1	DDR1_DQS3N	
R1	-	DDR2_DQS0N	
M1	-	DDR2_DQS1N	
G1	-	DDR2_DQS2N	
D1	-	DDR2_DQS3N	
A19	-	DDR3_DQS0N	
A22	-	DDR3_DQS1N	
A27	-	DDR3_DQS2N	
A30	-	DDR3_DQS3N	
R35	D25	MCU_ADC0_REFP	If the MCU_ADCn interface is not used, these signals should be connected to the same power supply as the VDDA_ADCn supply input.
AA35	C30	MCU_ADC1_REFP	
U35	C26	MCU_ADC0_REFN	If the MCU_ADCn interface is not used, these signals should be connected to VSS.
W35	D29	MCU_ADC1_REFN	
L29	F26	VPP_MCU	Each of these balls must be left unconnected, if unused.
AA31	V29	VPP_CORE	
AJ7	AH2	MMC0_CALPAD	

Table 5-121. Connectivity Requirements (continued)

ALY BALL NUMBER	AND BALL NUMBER	BALL NAME	CONNECTION REQUIREMENT
		DDR0_*	DDRSS0, DDRSS1, DDRSS2 and DDRSS3 must always be used in incremental order. For instance, when using a single LPDDR component, it must be connected to the DDR0_* interface. When using two LPDDR components, they must be connected to DDR0_* and DDR1_* interfaces, and so forth.
		DDR1_*	
		DDR2_*	
		DDR3_*	

Table 5-122 shows the specific connection requirements for the RESERVED ball numbers on the device.

Note

For additional clarification, "left unconnected" or "no connect" (NC) means **no** signal traces can be connected to these device ball numbers.

Table 5-122. Reserved Balls Specific Connection Requirements

ALY BALL NUMBERS	AND BALL NUMBERS	CONNECTION REQUIREMENTS
AF7 / AK2 / AK29 / AK31 / AL11 / AL23 / AL24 / AL25 / AL27 / AL30 / AM10 / AM12 / AM14 / AM16 / AM17 / AM21 / AM22 / AM26 / AM29 / AM33 / AM9 / AN13 / AN20 / AN21 / G17 / G22 / G30 / H12 / H14 / H32 / H33 / J31 / J33 / K30 / L30 / N7 / T7 / Y7	AH4 / AH7 / AH8 / E28 / F27 / J29 / L28 / L29 / L30 / M30	RESERVED. These balls must be left unconnected.

6 Specifications

6.1 Absolute Maximum Ratings

over operating free-air temperature range (unless otherwise noted)^{(1) (2)}

PARAMETER		MIN	MAX	UNIT
VDD_*(3)	Core supplies	-0.3	1.05	V
VDDAR_*(3)	RAM supplies	-0.3	1.05	V
VDDA_0P8_*(3)	Analog supplies for 0.8V domains	-0.3	1.05	V
VDDA_1P8_*(3)	Analog supplies for 1.8 V PHY domains	-0.3	2.2	V
VDDA_3P3_USB	Analog supply for 3.3V USB domain	-0.3	3.8	V
VDDA_*(3)	Analog supply for 1.8V PLL and other domains	-0.3	2.2	V
VDDS_DDR_*(3)	DDR interface power supplies	-0.3	1.2	V
VDDS_MMC0	MMC0 IO supply	-0.3	2.2	V
VDDSHV*(3)	Dual Voltage LVCMOS IO supplies	1.8 V	2.2	V
		3.3 V	3.8	V
VPP_CORE VPP MCU	Supply voltage range for EFUSE domains	-0.3	1.89	V
USB0_VBUS(9)	Voltage range for USB VBUS comparator input	-0.3	3.6	V
Steady State Max. Voltage at all fail-safe IO pins	I2C0_SCL, I2C0_SDA, WKUP_I2C0_SCL, WKUP_I2C0_SDA, MCU_I2C0_SCL, MCU_I2C0_SDA, EXTINTn	-0.3	3.8	V
	MCU_PORz, PORz	-0.3	3.8	V
Steady State Max. Voltage at all other IO pins(4)	VMON1_ER_VSYS(8), VMON3_IR_VEXT1P8, VMON4_IR_VEXT1P8	-0.3	2.2	V
	VMON2_IR_VCPU	-0.3	1.05	V
	VMON5_IR_VEXT3P3	-0.3	3.8	V
	All other IO pins	-0.3	IO supply voltage + 0.3	V
Transient Overshoot and Undershoot specification at IO pin	20% of IO supply voltage for up to 20% of signal period Figure 6-1 (see <i>IO Transient Voltage Ranges</i>)		$0.2 \times VDD^{(7)}$	V
Latch-up Performance, Class II (125°C)(5)	I-Test	-100	100	mA
	Over-Voltage (OV) Test	NA	$1.5 \times VDD^{(7)}$	V
T _{STG} (6)	Storage temperature	-55	+150	°C

- (1) Operation outside the Absolute Maximum Ratings may cause permanent device damage. Absolute Maximum Ratings do not imply functional operation of the device at these or any other conditions beyond those listed under [Recommended Operating Conditions](#). If used outside the Recommended Operating Conditions but within the Absolute Maximum Ratings, the device may not be fully functional, and this may affect device reliability, functionality, performance, and shorten the device lifetime.

- (2) All voltage values are with respect to their associated VSS or VSSA_x, unless otherwise noted.
- (3) **VDD_* includes:** VDD_CORE, VDD_CPU, VDD_MCU, VDD_MCU_WAKE1, VDD_WAKE0
VDDAR_* includes: VDDAR_CORE, VDDAR_CPU, VDDAR_MCU
VDDA_0P8_* includes: VDDA_0P8_CSIRX0_1, VDDA_0P8_CSIRX2, VDDA_0P8_DLL_MMC0, VDDA_0P8_DSITX, VDDA_0P8_DSITX_C, VDDA_0P8_PLL_DDR0, VDDA_0P8_PLL_DDR1, VDDA_0P8_PLL_DDR2, VDDA_0P8_PLL_DDR3, VDDA_0P8_SERDES_C0_1, VDDA_0P8_SERDES_C2, VDDA_0P8_SERDES_C4, VDDA_0P8_SERDES0_1, VDDA_0P8_SERDES2, VDDA_0P8_SERDES4, VDDA_0P8_UFS, VDDA_0P8_USB
VDDA_1P8_* includes: VDDA_1P8_CSIRX0_1, VDDA_1P8_CSIRX2, VDDA_1P8_DSITX, VDDA_1P8_SERDES0_1, VDDA_1P8_SERDES2, VDDA_1P8_SERDES2_4, VDDA_1P8_SERDES4, VDDA_1P8_UFS, VDDA_1P8_USB
VDDA_* includes: VDDA_ADC0, VDDA_ADC1, VDDA_MCU_PLLGRP0, VDDA_MCU_TEMP, VDDA_OSC1, VDDA_PLLGRP0, VDDA_PLLGRP1, VDDA_PLLGRP10, VDDA_PLLGRP12, VDDA_PLLGRP13, VDDA_PLLGRP2, VDDA_PLLGRP5, VDDA_PLLGRP6, VDDA_PLLGRP7, VDDA_PLLGRP8, VDDA_PLLGRP9, VDDA_POR_WKUP, VDDA_TEMP0, VDDA_TEMP1, VDDA_TEMP2, VDDA_TEMP3, VDDA_TEMP4, VDDA_WKUP
VDDS_DDR_* includes: VDDS_DDR, VDDS_DDR_C0, VDDS_DDR_C1, VDDS_DDR_C2, VDDS_DDR_C3
VDDSHV* includes: VDDSHV0, VDDSHV0_MCU, VDDSHV1_MCU, VDDSHV2, VDDSHV2_MCU, VDDSHV5
- (4) This parameter applies to all IO pins which are not fail-safe and the requirement applies to all values of IO supply voltage. For example, if the voltage applied to a specific IO supply is 0 volts the valid input voltage range for any IO powered by that supply will be -0.3 to +0.3 volts. Special attention should be applied anytime peripheral devices are not powered from the same power sources used to power the respective IO supply. It is important the attached peripheral never sources a voltage outside the valid input voltage range, including power supply ramp-up and ramp-down sequences.
- (5) For current pulse injection:
Pins stressed per JEDEC JESD78E (Class II) and passed with specified I/O pin injection current and clamp voltage of 1.5 times maximum recommended I/O voltage and negative 0.5 times maximum recommended I/O voltage.
For overvoltage performance:
Supplies stressed per JEDEC JESD78E (Class II) and passed specified voltage injection.
- (6) For tape and reel the storage temperature range is [-10°C; +50°C] with a maximum relative humidity of 70%. TI recommends returning to ambient room temperature before usage.
- (7) VDD is the voltage on the corresponding power-supply pin(s) for the IO.
- (8) The VMON_ER_VSYS pin provides a way to monitor the system power supply. For more information, see [System Power Supply Monitor Design Guidelines using VMON/POK](#).
- (9) An external resistor divider is required to limit the voltage applied to this device pin. For more information, see the [USB VBUS Design Guidelines](#).

Fail-safe IO terminals are designed such they do not have dependencies on the respective IO power supply voltage. This allows external voltage sources to be connected to these IO terminals when the respective IO power supplies are turned off. The I2C0_SCL, I2C0_SDA, I2C1_SCL, I2C1_SDA, DDR_FS_RESEt_n, and NMI_n are the only fail-safe IO terminals. All other IO terminals are not fail-safe and the voltage applied to them should be limited to the value defined by the Steady State Max. Voltage at all IO pins parameter in [Absolute Maximum Ratings](#).

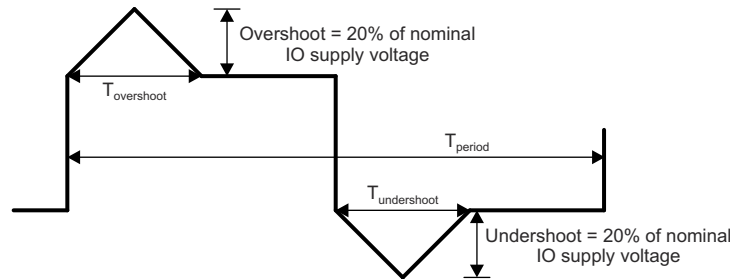

A. $T_{overshoot} + T_{undershoot} < 20\%$ of T_{period}

Figure 6-1. IO Transient Voltage Ranges

6.2 ESD Ratings

			VALUE	UNIT	
V _(ESD)	Electrostatic discharge	Human-body model (HBM), per AEC Q100-002 ⁽¹⁾	±1000	V	
		Charged-device model (CDM), per AEC Q100-011	All pins		±250
			Corner pins (A1, AJ29)		±750

(1) AEC Q100-002 indicates that HBM stressing shall be in accordance with the ANSI/ESDA/JEDEC JS-001 specification.

6.3 Power-On-Hour (POH) Limits

IP ⁽¹⁾ (2) (3)	VOLTAGE DOMAIN	VOLTAGE (V) (MAX)	FREQUENCY (MHz) (MAX)	T _j (°C)	POH
All	100%	All	All Supported OPPs	Automotive -40°C to 125°C ⁽⁴⁾	20000
All	100%	All	All Supported OPPs	Extended -40°C to 105°C	100000
All	100%	All	All Supported OPPs	Commercial 0°C to 90°C	100000

- (1) The information in the section below is provided solely for your convenience and does not extend or modify the warranty provided under TI's standard terms and conditions for TI semiconductor products.
- (2) Unless specified in the table above, all voltage domains and operating conditions are supported in the device at the noted temperatures
- (3) POH is a functional of voltage, temperature and time. Usage at higher voltages and temperatures will result in a reduction in POH to achieve the same reliability performance. For assessment of alternate use cases, contact your local TI representative.
- (4) Automotive profile is defined as 20000 power on hours with junction temperature as follows: 5%@-40°C, 65%@70°C, 20%@110°C, 10%@125°C.

6.4 Recommended Operating Conditions

over operating free-air temperature range (unless otherwise noted)

SUPPLY NAME	DESCRIPTION	MIN ⁽¹⁾	NOM	MAX ⁽¹⁾	UNIT	
VDD_CORE	Boot/Active voltage for MAIN domain core supply	0.76 ⁽¹⁾	0.8	0.84 ⁽¹⁾	V	
VDD_MCU	Boot/Active voltage for MCUSS core supply	0.76 ⁽¹⁾	0.8	0.89 ⁽¹⁾	V	
VDD_CPU	Boot voltage for CPU core supply, applied at cold power up event	0.76 ⁽¹⁾	0.8	0.84 ⁽¹⁾	V	
	Active voltage for CPU core supply, after AVS mode enabled in software	AVS ⁽³⁾ –5% ⁽¹⁾	AVS ⁽³⁾	AVS ⁽³⁾ +5% ⁽¹⁾	V	
VDD_CPU AVS Range	AVS valid voltage range for VDD_CPU	0.6		0.9	V	
VDDAR_*(⁵)	RAM supplis	0.81	0.85	0.89	V	
VDDA_0P8_*(⁵)	Analog supplies for 0.8V domains	0.76	0.8	0.84	V	
VDDA_1P8_*(⁵)	Analog supplies for 1.8V PHY domains	1.71	1.8	1.89	V	
VDDA_3P3_USB(⁵)	Analog supply for 3.3V USB domain	3.14	3.3	3.46	V	
VDDA_*(⁵)	Analog supply for 1.8V PLL and other domains	1.71	1.8	1.89	V	
VDDA_*	Peak to Peak Noise for all VDDA inputs			25	mV	
VDDS_DDR_*(⁵)	DDR interface power supply	1.06	1.1	1.15	V	
VDDS_MMC0	MMC0 IO supply	1.71	1.8	1.89	V	
VDDSHV*(⁵)	Dual Voltage LVCMOS IO supplies	1.8-V operation	1.71	1.8	1.89	V
		3.3-V operation	3.14	3.3	3.46	V
USB0_VBUS	Voltage range for USB VBUS comparator input	0	See ⁽⁴⁾	3.46	V	
USB0_ID	Voltage range for the USB ID input		See ⁽²⁾		V	
VSS	Ground		0		V	
T _J	Operating junction temperature range	Automotive	-40	125	°C	
		Extended	-40	105	°C	
		Commercial	0	90	°C	

- (1) For all VDD* supply inputs, the voltage at the device ball must never be below the MIN voltage or above the MAX voltage for any amount of time. This requirement includes dynamic voltage events such as AC ripple, voltage transients, voltage dips, and so forth. This is required for all supply inputs, but special care should be given to the VDD_CORE, VDD_MCU, and VDD_CPU domains which have higher transient current demand compared to other rails.
- (2) This terminal is connected to analog circuits in the respective USB PHY. The circuit sources a known current while measuring the voltage to determine if the terminal is connected to VSS with a resistance less than 10 Ω or greater than 100 kΩ. The terminal should be connected to ground for USB host operation or open-circuit for USB peripheral operation, and should never be connected to any external voltage source.
- (3) The AVS Voltages are device-dependent, voltage domain-dependent, and OPP-dependent. They must be read from the VTM_DEVINFO_VDn. For information about VTM_DEVINFO_VDn Registers address, please refer to Voltage and Thermal Manager section in the device TRM. The power supply should be adjustable over the ranges shown in the VDD_CPU AVS Range entry.

- (4) An external resistor divider is required to limit the voltage applied to this device pin. For more information, see [USB VBUS Design Guidelines](#).
- (5) **VDD_* includes:** VDD_CORE, VDD_CPU, VDD_MCU, VDD_MCU_WAKE1, VDD_WAKE0
VDDAR_* includes: VDDAR_CORE, VDDAR_CPU, VDDAR_MCU
VDDA_0P8_* includes: VDDA_0P8_CSIRX0_1, VDDA_0P8_CSIRX2, VDDA_0P8_DLL_MMC0, VDDA_0P8_DSITX, VDDA_0P8_DSITX_C, VDDA_0P8_PLL_DDR0, VDDA_0P8_PLL_DDR1, VDDA_0P8_PLL_DDR2, VDDA_0P8_PLL_DDR3, VDDA_0P8_SERDES_C0_1, VDDA_0P8_SERDES_C2, VDDA_0P8_SERDES_C4, VDDA_0P8_SERDES0_1, VDDA_0P8_SERDES2, VDDA_0P8_SERDES4, VDDA_0P8_UFS, VDDA_0P8_USB
VDDA_1P8_* includes: VDDA_1P8_CSIRX0_1, VDDA_1P8_CSIRX2, VDDA_1P8_DSITX, VDDA_1P8_SERDES0_1, VDDA_1P8_SERDES2, VDDA_1P8_SERDES2_4, VDDA_1P8_SERDES4, VDDA_1P8_UFS, VDDA_1P8_USB
VDDA_* includes: VDDA_ADC0, VDDA_ADC1, VDDA_MCU_PLLGRP0, VDDA_MCU_TEMP, VDDA_OSC1, VDDA_PLLGRP0, VDDA_PLLGRP1, VDDA_PLLGRP10, VDDA_PLLGRP12, VDDA_PLLGRP13, VDDA_PLLGRP2, VDDA_PLLGRP5, VDDA_PLLGRP6, VDDA_PLLGRP7, VDDA_PLLGRP8, VDDA_PLLGRP9, VDDA_POR_WKUP, VDDA_TEMP0, VDDA_TEMP1, VDDA_TEMP2, VDDA_TEMP3, VDDA_TEMP4, VDDA_WKUP
VDDS_DDR_* includes: VDDS_DDR, VDDS_DDR_C0, VDDS_DDR_C1, VDDS_DDR_C2, VDDS_DDR_C3
VDDSHV* includes: VDDSHV0, VDDSHV0_MCU, VDDSHV1_MCU, VDDSHV2, VDDSHV2_MCU, VDDSHV5

6.5 Operating Performance Points

This section describes the operating conditions of the device. This section also contains the description of each Operating Performance Point (OPP) for processor clocks and device core clocks.

[Table 6-1](#) describes the maximum supported frequency per speed grade for the device.

Table 6-1. Speed Grade Maximum Frequency

DEVICE	MAXIMUM FREQUENCY (MHz)									
	A72SS0	C71SS0	R5FSS0/1	MCU_ R5SS0	GPU	CBASS0	VPAC	VENCDEC	DMSC	LPDDR4
AM69Ax...T	2000	1000	1000	1000	800	500	720	550 (960 or 480MP/s) ⁽²⁾	333	4266 MT/s ⁽¹⁾

- (1) Maximum DDR Frequency will be limited based on the specific memory type (vendor) used in a system and by PCB implementation. TI strongly recommends all designs to follow the TI LPDDR4 EVM PCB layout exactly in every detail (routing, spacing, vias/backdrill, PCB material, etc.) in order to achieve the full specified clock frequency. Refer to the Jacinto 7 [LPDDR Board Design and Layout Guidelines](#) for details
- (2) Refer to the [Device Comparison](#) table to determine specific part numbers that include 1 × VENCDEC module (480 MP/s) or 2 × VENCDEC modules (960 MP/s).

6.6 Electrical Characteristics

Note

The interfaces or signals described in [Section 6.6.1](#) through [Section 6.6.8](#) correspond to the interfaces or signals available in multiplexing mode 0 (Primary Function).

All interfaces or signals multiplexed on the balls described in these tables have the same DC electrical characteristics, unless multiplexing involves a PHY and GPIO combination, in which case different DC electrical characteristics are specified for the different multiplexing modes (Functions).

6.6.1 I2C, Open-Drain, Fail-Safe (I2C OD FS) Electrical Characteristics

Over recommended operating conditions (unless otherwise noted)

PARAMETER		TEST CONDITIONS	MIN	TYP	MAX	UNIT
1.8-V MODE						
V _{IL}	Input low-level threshold				0.3 × VDDSHV ⁽¹⁾	V
V _{ILSS}	Input low-level threshold steady state				0.3 × VDDSHV ⁽¹⁾	V
V _{IH}	Input high-level threshold		0.7 × VDDSHV ⁽¹⁾			V
V _{IHSS}	Input high-level threshold steady state		0.7 × VDDSHV ⁽¹⁾			V
V _{HYS}	Input Hysteresis Voltage		0.1 × VDDSHV ⁽¹⁾			mV
I _{IN}	Input Leakage Current	V _I = 1.8 V or 0 V			±10	µA
V _{OL}	Output low-level voltage				0.2 × VDDSHV ⁽¹⁾	V
I _{OL}	Low Level Output Current	V _{OL(MAX)}	6			mA
3.3-V MODE						
V _{IL}	Input low-level threshold				0.3 × VDDSHV ⁽¹⁾	V
V _{ILSS}	Input low-level threshold steady state				0.25 × VDDSHV ⁽¹⁾	V
V _{IH}	Input high-level threshold		0.7 × VDDSHV ⁽¹⁾			V
V _{IHSS}	Input high-level threshold steady state		0.7 × VDDSHV ⁽¹⁾			V
V _{HYS}	Input Hysteresis Voltage		0.05 × VDDSHV ⁽¹⁾			mV
I _{IN}	Input Leakage Current	V _I = 3.3 V or 0 V			±10	µA
V _{OL}	Output low-level voltage				0.4	V
I _{OL}	Low Level Output Current	V _{OL(MAX)}	6			mA

(1) VDDSHV stands for corresponding power supply. For more information on the power supply name and the corresponding ball, see the [Pin Attributes](#), POWER column.

6.6.2 Fail-Safe Reset (FS Reset) Electrical Characteristics

Over recommended operating conditions (unless otherwise noted)

PARAMETER		TEST CONDITIONS	MIN	TYP	MAX	UNIT
V _{IL}	Input low-level threshold				0.3 × VDDSHV ⁽¹⁾	V
V _{ILSS}	Input low-level threshold steady state				0.3 × VDDSHV ⁽¹⁾	V

Over recommended operating conditions (unless otherwise noted)

PARAMETER		TEST CONDITIONS	MIN	TYP	MAX	UNIT
V _{IH}	Input high-level threshold		0.7 × VDDSHV ⁽¹⁾			V
V _{IHSS}	Input high-level threshold steady state		0.7 × VDDSHV ⁽¹⁾			V
V _{HYS}	Input Hysteresis Voltage		200			mV
I _{IN}	Input Leakage Current	V _I = 1.8 V or 0 V			±10	μA

(1) VDDSHV stands for corresponding power supply. For more information on the power supply name and the corresponding ball, see the *Pin Attributes*, POWER column.

6.6.3 HFOSC/LFOSC Electrical Characteristics

Over recommended operating conditions (unless otherwise noted)

PARAMETER		TEST CONDITIONS	MIN	TYP	MAX	UNIT
HIGH FREQUENCY OSCILLATOR						
V _{IH}	Input high-level threshold		0.65 × VDDSHV ⁽¹⁾			V
V _{IL}	Input low-level threshold				0.35 × VDDSHV ⁽¹⁾	V
V _{HYS}	Input Hysteresis Voltage			49		mV
LOW FREQUENCY OSCILLATOR						
V _{IH}	Input high-level threshold		0.65 × VDDA_WKUP ⁽¹⁾			V
V _{IL}	Input low-level threshold				0.35 × VDDA_WKUP ⁽¹⁾	V
V _{HYS}	Input Hysteresis Voltage	Active Mode		85		mV
		Bypass Mode		324		mV

(1) VDDSHV stands for corresponding power supply. For WKUP_OSC0, the corresponding power supply is VDDA_WKUP. For OSC1_XI, the corresponding power supply is VDDS_OSC1.

6.6.4 eMMC PHY Electrical Characteristics

Over operating free-air temperature range (unless otherwise noted)

PARAMETER		TEST CONDITIONS	MIN	NOM	MAX	UNIT
V _{IL}	Input low-level threshold				0.35 × VDDSHV ⁽¹⁾	V
V _{ILSS}	Input low-level threshold steady state				0.20	V
V _{IH}	Input high-level threshold		0.65 × VDDSHV ⁽¹⁾			V
V _{IHSS}	Input high-level threshold steady state		1.4			V
I _{IN}	Input Leakage Current	V _I = 1.8 V or 0 V			±10	μA
I _{OZ}	Tri-state Output Leakage Current	V _O = 1.8 V or 0 V			±10	μA
R _{PU}	Pull-up Resistor		15	20	25	kΩ
R _{PD}	Pull-down Resistor		15	20	25	kΩ
V _{OL}	Output low-level voltage				0.30	V
V _{OH}	Output high-level voltage		VDDSHV - 0.30 ⁽¹⁾			V
I _{OL}	Low Level Output Current	V _{OL(MAX)}	2			mA
I _{OH}	High Level Output Current	V _{OH(MAX)}	2			mA

Over operating free-air temperature range (unless otherwise noted)

PARAMETER		TEST CONDITIONS	MIN	NOM	MAX	UNIT
SR _I	Input Slew Rate		5E +8			V/s

- (1) VDDSHV stands for corresponding power supply (vddshv8). For more information on the power supply name and the corresponding ball, see the *Pin Attributes*, POWER column..

6.6.5 SDIO Electrical Characteristics

Over operating free-air temperature range (unless otherwise noted)

PARAMETER		TEST CONDITIONS	MIN	NOM	MAX	UNIT
1.8-V MODE						
V _{IL}	Input low-level threshold				0.58	V
V _{ILSS}	Input low-level threshold steady state				0.58	V
V _{IH}	Input high-level threshold		1.27			V
V _{IHSS}	Input high-level threshold steady state		1.7			V
V _{HYS}	Input Hysteresis Voltage		150			mV
I _{IN}	Input Leakage Current	V _I = 1.8 V or 0 V			±10	µA
R _{PU}	Pull-up Resistor		40	50	60	kΩ
R _{PD}	Pull-down Resistor		40	50	60	kΩ
V _{OL}	Output low-level voltage				0.45	V
V _{OH}	Output high-level voltage		VDDSHV-0.45 ⁽¹⁾			V
I _{OL}	Low Level Output Current	V _{OL(MAX)}	4			mA
I _{OH}	High Level Output Current	V _{OH(MAX)}	4			mA
3.3-V Mode						
V _{IL}	Input low-level threshold				0.25 × VDDSHV ⁽¹⁾	V
V _{ILSS}	Input low-level threshold steady state				0.15 × VDDSHV ⁽¹⁾	V
V _{IH}	Input high-level threshold		0.625 × VDDSHV ⁽¹⁾			V
V _{IHSS}	Input high-level threshold steady state		0.625 × VDDSHV ⁽¹⁾			V
V _{HYS}	Input Hysteresis Voltage		150			mV
I _{IN}	Input Leakage Current	V _I = 1.8 V or 0 V			±10	µA
R _{PU}	Pull-up Resistor		40	50	60	kΩ
R _{PD}	Pull-down Resistor		40	50	60	kΩ
V _{OL}	Output low-level voltage				0.125 × VDDSHV ⁽¹⁾	V
V _{OH}	Output high-level voltage		0.75 × VDDSHV ⁽¹⁾			V
I _{OL}	Low Level Output Current	V _{OL(MAX)}	6			mA
I _{OH}	High Level Output Current	V _{OH(MAX)}	10			mA

- (1) VDDSHV stands for corresponding power supply (vddshv8). For more information on the power supply name and the corresponding ball, see the *Pin Attributes* , POWER column.

6.6.6 CSI2/DSI D-PHY Electrical Characteristics

Over operating free-air temperature range (unless otherwise noted)

PARAMETER		MIN	NOM	MAX	UNIT
Low-Power Receiver (LP-RX)					
V _{IH}	Input high-level threshold	740			mV

Over operating free-air temperature range (unless otherwise noted)

PARAMETER		MIN	NOM	MAX	UNIT
V _{IL}	Input low-level threshold			550	mV
V _{HYS}	Hysteresis	25			mV
Ultra-Low Power Receiver (ULP-RX)					
V _{ITH}	Input high-level threshold	740			mV
V _{ITL-ULPM}	Input low-level threshold			300	mV
V _{HYS}	Hysteresis	25			mV
High Speed Receiver (HS-RX)					
V _{IDTH}	Differential input high-level threshold			40	mV
V _{IDTL}	Differential input low-level threshold	-40			mV
V _{IDMAX}	Maximum differential input voltage			270	mV
V _{ILHS}	Single-ended input low-level threshold	-40			mV
V _{IHHS}	Single-ended input high-level threshold			460	mV
V _{CMRXDC}	Common-mode voltage	70		330	mV

6.6.7 ADC12B Electrical Characteristics

Over recommended operating conditions (unless otherwise noted)

PARAMETER		TEST CONDITIONS	MIN	TYP	MAX	UNIT
Analog Input						
V _{MCU_ADC0/1_AIN[7:0]}	Full-scale Input Range		VSS	VDDA_ADC0/1		V
DNL	Differential Non-Linearity		-1	0.5	4	LSB
INL	Integral Non-Linearity			±1	±4	LSB
LSB _{GAIN-ERROR}	Gain Error			±2		LSB
LSB _{OFFSET-ERROR}	Offset Error			±2		LSB
C _{IN}	Input Sampling Capacitance			5.5		pF
SNR	Signal-to-Noise Ratio	Input Signal: 200 kHz sine wave at -0.5 dB Full Scale		70		dB
THD	Total Harmonic Distortion	Input Signal: 200 kHz sine wave at -0.5 dB Full Scale		73		dB
SFDR	Spurious Free Dynamic Range	Input Signal: 200 kHz sine wave at -0.5 dB Full Scale		76		dB
SNR _(PLUS)	Signal-to-Noise Plus Distortion	Input Signal: 200 kHz sine wave at -0.5 dB Full Scale		69		dB
R _{MCU_ADC0/1_AIN[0:7]}	Input Impedance of MCU_ADC0/1_AIN[7:0]	f = input frequency		$[1/((65.97 \times 10^{-12}) \times f_{\text{SMPL_CLK}})]$		Ω
I _{IN}	Input Leakage	MCU_ADC0/1_AIN[7:0] = VSS			-10	μA
		MCU_ADC0/1_AIN[7:0] = VDDA_ADC0/1			24	μA
Sampling Dynamics						
F _{SMPL_CLK}	SMPL_CLK Frequency			60		MHz
t _C	Conversion Time			13		ADC0/1 SMPL_CLK Cycles

Over recommended operating conditions (unless otherwise noted)

PARAMETER		TEST CONDITIONS	MIN	TYP	MAX	UNIT
t _{ACQ}	Acquisition time		2		257	ADC0/1 SMPL_CLK K Cycles
T _R	Sampling Rate	ADC0/1 SMPL_CLK = 60 MHz		4		MSPS
CCISO	Channel to Channel Isolation			100		dB
General Purpose Input Mode⁽¹⁾						
V _{IL}	Input low-level threshold				0.35 × VDDA_ADC0/ 1	V
V _{ILSS}	Input high-level threshold steady state				0.35 × VDDA_ADC0/ 1	V
V _{IH}	Input high-level threshold		0.65 × VDDA_ADC0/ 1			V
V _{IHSS}	Input high-level threshold steady state		0.65 × VDDA_ADC0/ 1			V
V _{HYS}	Input Hysteresis Voltage		200			mV
I _{IN}	Input Leakage Current	V _I = 1.8 V or 0 V			6	μA

(1) MCU_ADC0/1 can be configured to operate in General Purpose Input mode, where all MCU_ADC0/1_AIN[7:0] inputs are globally enabled to operate as digital inputs via the ADC0/1_CTRL register (gpi_mode_en = 1).

6.6.8 LVCMOS Electrical Characteristics

Over recommended operating conditions (unless otherwise noted)

PARAMETER		TEST CONDITIONS	MIN	TYP	MAX	UNIT
1.8-V MODE						
V _{IL}	Input Low Voltage				0.35 × VDD ⁽¹⁾	V
V _{ILSS}	Input Low Voltage Steady State				0.3 × VDD ⁽¹⁾	V
V _{IH}	Input High Voltage		0.65 × VDD ⁽¹⁾			V
V _{IHSS}	Input High Voltage Steady State		0.85 × VDD ⁽¹⁾			V
V _{HYS}	Input Hysteresis Voltage		150			mV
I _{IN}	Input Leakage Current.	V _I = 1.8 V or 0 V			±10	μA
R _{PU}	Pull-up Resistor		15	22	30	kΩ
R _{PD}	Pull-down Resistor		15	22	30	kΩ
V _{OL}	Output Low Voltage				0.45	V
V _{OH}	Output High Voltage		VDD ⁽¹⁾ - 0.45			V
I _{OL}	Low Level Output Current	V _{OL(MAX)}	3			mA
I _{OH}	High Level Output Current	V _{OH(MIN)}	3			mA
3.3-V MODE						
V _{IL}	Input Low Voltage				0.8	V
V _{ILSS}	Input Low Voltage Steady State				0.6	V
V _{IH}	Input High Voltage		2.0			V
V _{IHSS}	Input High Voltage Steady State		2.0			V
V _{HYS}	Input Hysteresis Voltage		150			mV
I _{IN}	Input Leakage Current.	V _I = 3.3 V or 0 V			±10	μA
R _{PU}	Pull-up Resistor		15	22	30	kΩ
R _{PD}	Pull-down Resistor		15	22	30	kΩ

Over recommended operating conditions (unless otherwise noted)

PARAMETER		TEST CONDITIONS	MIN	TYP	MAX	UNIT
V _{OL}	Output Low Voltage				0.4	V
V _{OH}	Output High Voltage		2.4			V
I _{OL}	Low Level Output Current	V _{OL(MAX)}	5			mA
I _{OH}	High Level Output Current	V _{OH(MIN)}	6			mA

- (1) VDD stands for corresponding power supply. For more information on the power supply name and the corresponding ball, see the *Pin Attributes*, POWER column.

6.6.9 USB2PHY Electrical Characteristics

Note

USB0 and USB1 Electrical Characteristics are compliant with Universal Serial Bus Revision 2.0 Specification dated April 27, 2000 including ECNs and Errata as applicable.

6.6.10 SerDes 2-L-PHY/4-L-PHY Electrical Characteristics

Note

The PCIe interfaces are compliant with the electrical parameters specified in PCI Express® Base Specification Revision 4.0, September 27, 2017.

This Device imposes an additional limit on SERDES REFCLK when used in Input mode with internal termination enabled, as described by parameter V_{REFCLK_TERM} in Table 6-2, 4-L-PHY SERDES REFCLK Electrical Characteristics. Internal termination is enabled by default and must be disabled before applying a reference clock signal that exceeds the limits defined by V_{REFCLK_TERM}. External termination should always be enabled on the source side.

Table 6-2. 4-L-PHY SERDES REFCLK Electrical Characteristics

Only applies when internal termination is enabled. Over recommended operating conditions (unless otherwise noted)

PARAMETER		MIN	TYP	MAX	UNIT
V _{REFCLK_TERM}	Single ended voltage threshold at the reference clock pin when internal termination is enabled			400	mV
R _{TERM}	Internal termination	40	50	62.5	Ω

Note

The SerDes USB interfaces are compliant with the USB3.1 SuperSpeed Transmitter and Receiver Normative Electrical Parameters as defined in the Universal Serial Bus 3.1 Specification, Revision 1.0, July 26, 2013.

Note

The SGMII interfaces electrical characteristics are compliant with 1000BASE-KX per IEEE802.3 Clause 70.

Note

The SGMII 2.5G / XAUI interfaces electrical characteristics are compliant with IEEE802.3 Clause 47.

Note

The QSGMII interface electrical characteristics are compliant with QSGMII Specification revision 1.2.

Note

The UFS interface electrical characteristics are compliant with MIPI M-PHY Specification v3.1, February 17, 2014.

Note

The DP interface electrical characteristics are compliant with the VESA DisplayPort (DP) Standard v 1.4 February 23, 2016.

Note

The eDP interface electrical characteristics are compliant with the VESA Embedded DisplayPort (eDP) Standard v1.4b October 23, 2015.

6.6.13 DDR0 Electrical Characteristics

Note

The DDR interface is compatible with JESD209-4B standard compliant LPDDR4 SDRAM devices.

6.7 VPP Specifications for One-Time Programmable (OTP) eFuses

This section specifies the operating conditions required for programming the OTP eFuses and is applicable only for High-Security Devices.

6.7.1 Recommended Operating Conditions for OTP eFuse Programming

over operating free-air temperature range (unless otherwise noted)

PARAMETER	DESCRIPTION	MIN	NOM	MAX	UNIT
VDD_CORE	Supply voltage range for the core domain during OTP operation; OPP NOM (BOOT)	See Recommended Operating Conditions			V
VDD_MCU	Supply voltage range for the core domain during OTP operation; OPP NOM (BOOT)	See Recommended Operating Conditions			V
VPP_CORE	Supply voltage range for the eFuse ROM domain during normal operation	N/A ⁽²⁾			
	Supply voltage range for the eFuse ROM domain during OTP programming ⁽¹⁾	1.71	1.8	1.89	V
VPP_MCU	Supply voltage range for the eFuse ROM domain during normal operation	N/A ⁽²⁾			
	Supply voltage range for the eFuse ROM domain during OTP programming ⁽¹⁾	1.71	1.8	1.89	V

(1) Supply voltage range includes DC errors and peak-to-peak noise.

(2) N/A stands for Not Applicable.

6.7.2 Hardware Requirements

The following hardware requirements must be met when programming keys in the OTP eFuses:

- The VPP_CORE and VPP_MCU power supplies must be disabled when not programming OTP registers.
- The VPP_CORE and VPP_MCU power supplies must be ramped up after the proper device power-up sequence (for more details, see *Power Supply Sequencing*).

6.7.3 Programming Sequence

Programming sequence for OTP eFuses:

- Power on the board per the power-up sequencing. No voltage should be applied on the VPP_CORE and VPP_MCU terminals during power up and normal operation.
- Load the OTP write software required to program the eFuse (contact your local TI representative for the OTP software package).
- Apply the voltage on the VPP_CORE and VPP_MCU terminals according to the specification in [Section 6.7.1](#).
- Run the software that programs the OTP registers.
- After validating the content of the OTP registers, remove the voltage from the VPP_CORE and VPP_MCU terminals.

6.7.4 Impact to Your Hardware Warranty

You recognize and accept at your own risk that your use of eFuse permanently alters the TI device. You acknowledge that eFuse can fail due to incorrect operating conditions or programming sequence. Such a failure may render the TI device inoperable and TI will be unable to confirm the TI device conformed to TI device specifications prior to the attempted eFuse. CONSEQUENTLY, TI WILL HAVE NO LIABILITY FOR ANY TI DEVICES THAT HAVE BEEN eFUSED.

6.8 Thermal Resistance Characteristics

This section provides the thermal resistance characteristics used on this device.

For reliability and operability concerns, the maximum junction temperature of the device has to be at or below the T_J value identified in [Recommended Operating Conditions](#).

6.8.1 Thermal Resistance Characteristics for ALY Package

It is recommended to perform thermal simulations at the system level with the worst case device power consumption.

NO.	PARAMETER	DESCRIPTION	ALY PACKAGE	
			$^{\circ}\text{C}/\text{W}^{(1) (3)}$	AIR FLOW (m/s) ⁽²⁾
T1	$\text{R}\theta_{\text{JC}}$	Junction-to-case	0.11	N/A
T2	$\text{R}\theta_{\text{JB}}$	Junction-to-board	1.6	N/A
T3	$\text{R}\theta_{\text{JA}}$	Junction-to-free air	8.3	0
T4		Junction-to-moving air	4.7	1
T5			3.9	2
T7	Ψ_{JT}	Junction-to-package top	0.1	0
T8			0.1	1
T9			0.1	2
T11	Ψ_{JB}	Junction-to-board	1.3	0
T12			1.1	1
T13			1.0	2

(1) These values are based on a JEDEC defined 2S2P system (with the exception of the Theta JC [$\text{R}\theta_{\text{JC}}$] value, which is based on a JEDEC defined 1S0P system) and will change based on environment as well as application. For more information, see these EIA/JEDEC standards:

- JESD51-2, *Integrated Circuits Thermal Test Method Environment Conditions - Natural Convection (Still Air)*
- JESD51-3, *Low Effective Thermal Conductivity Test Board for Leaded Surface Mount Packages*
- JESD51-6, *Integrated Circuit Thermal Test Method Environmental Conditions - Forced Convection (Moving Air)*
- JESD51-7, *High Effective Thermal Conductivity Test Board for Leaded Surface Mount Packages*
- JESD51-9, *Test Boards for Area Array Surface Mount Packages*

(2) m/s = meters per second.

(3) $^{\circ}\text{C}/\text{W}$ = degrees Celsius per watt.

6.8.2 Thermal Resistance Characteristics for AND Package

It is recommended to perform thermal simulations at the system level with the worst case device power consumption.

NO.	PARAMETER	DESCRIPTION	AND PACKAGE	
			$^{\circ}\text{C}/\text{W}^{(1) (3)}$	AIR FLOW (m/s) ⁽²⁾
T1	$\text{R}\theta_{\text{JC}}$	Junction-to-case	0.16	N/A
T2	$\text{R}\theta_{\text{JB}}$	Junction-to-board	1.47	N/A
T3	$\text{R}\theta_{\text{JA}}$	Junction-to-free air	9.22	0
T4		Junction-to-moving air	5.07	1
T5			4.31	2
T7	Ψ_{JT}	Junction-to-package top	0.10	0
T8			0.10	1
T9			0.10	2

It is recommended to perform thermal simulations at the system level with the worst case device power consumption.

NO.	PARAMETER	DESCRIPTION	AND PACKAGE	
			°C/W ^{(1) (3)}	AIR FLOW (m/s) ⁽²⁾
T11	Ψ_{JB}	Junction-to-board	1.30	0
T12			1.23	1
T13			1.18	2

(1) These values are based on a JEDEC defined 2S2P system (with the exception of the Theta JC [R θ JC] value, which is based on a JEDEC defined 1S0P system) and will change based on environment as well as application. For more information, see these EIA/JEDEC standards:

- JESD51-2, *Integrated Circuits Thermal Test Method Environment Conditions - Natural Convection (Still Air)*
- JESD51-3, *Low Effective Thermal Conductivity Test Board for Leaded Surface Mount Packages*
- JESD51-6, *Integrated Circuit Thermal Test Method Environmental Conditions - Forced Convection (Moving Air)*
- JESD51-7, *High Effective Thermal Conductivity Test Board for Leaded Surface Mount Packages*
- JESD51-9, *Test Boards for Area Array Surface Mount Packages*

(2) m/s = meters per second.

(3) °C/W = degrees Celsius per watt.

6.9 Temperature Sensor Characteristics

This section summarizes the Voltage and Temperature Module (VTM) on die temperature sensor characteristics. For reliability and operability concerns, the maximum junction temperature of the device has to be at or below the T_J value identified in the [Recommended Operating Conditions](#).

Table 6-3. VTM Die Temperature sensor Characteristics

PARAMETER		TEST CONDITIONS	MIN	TYP	MAX	UNIT
T _{acc}	VTM temperature sensor accuracy	-40 to 110 °C	-5		5	°C
		110 to 125 °C	-2		2	°C

6.10 Timing and Switching Characteristics

Note

The timings presented in this section are valid when the DRV_STR (Drive Strength) control in the associated PADCONFIG registers are set to the default “0h – Nominal (recommended)” value.

6.10.1 Timing Parameters and Information

The timing parameter symbols used in [Timing and Switching Characteristics](#) are created in accordance with JEDEC Standard 100. To shorten the symbols, some pin names and other related terminologies have been abbreviated in [Table 6-4](#):

Table 6-4. Timing Parameters Subscripts

SYMBOL	PARAMETER
c	Cycle time (period)
d	Delay time
dis	Disable time
en	Enable time
h	Hold time
su	Setup time
START	Start bit
t	Transition time
v	Valid time
w	Pulse duration (width)
X	Unknown, changing, or don't care level
F	Fall time
H	High
L	Low
R	Rise time
V	Valid
IV	Invalid
AE	Active Edge
FE	First Edge
LE	Last Edge
Z	High impedance

6.10.2 Power Supply Sequencing

This section describes power supply sequencing required to ensure proper device operation. The device can be operated using either an isolated or combined MCU & Main power distribution network (PDN). Two different primary power sequences are recommended based upon isolated and combined MCU & Main PDNs. In addition, the device can be operated in either MCU Only or DDR Retention or GPIO Retention low power modes. Two different desired device power supply sequences for entry and exit of low power modes are shown.

The power supply names used in this section are specific to this device and align to names given in the Signal Descriptions section. Common power supply names may be used across different devices within the Jacinto 7™ processor family. These common supply names will have very similar if not identical functions across devices.

All power sequencing timing diagrams shown will use the following terminology:

- Primary = Essential power sequences of all voltage domains between off and full active states.
- $V_{OPR\ MIN}$ = Minimum operational voltage level that ensures functionality as specified in Recommended Operating Conditions
- Ramp-up = start of a voltage supply transition time from off condition to $V_{opr\ min}$.
- Ramp-down = start of a voltage supply transition time from V_{opr} to off condition
- Supply_“n” = multiple instances of similar power supplies (i.e. $VDDSHV_n = VDDSHV_0, VDDSHV_1, VDDSHV_2 \dots VDDSHV_6$)
- Supply_“xxx” = multiple instances of similar power supplies used for different signal types (i.e. $VDDA_{1P8_xxx} = VDDA_{1P8_DSITX}, VDDA_{1P8_USB}, VDDA_{0P8_DSITX}, VDDA_{0P8_USB}, \text{etc.}$)
- Time stamps = “T#” markers with descriptions and approximate elapsed times for general reference. Specific timing transitions are dependent upon PDN design (see PDN User Guide for details).

6.10.2.1 Power Supply Slew Rate Requirement

To maintain the safe operating range of the internal ESD protection devices, TI recommends limiting the maximum slew rate of supplies to be less than 100 mV/us, as shown in Figure 6-2. For instance, a 1.8V supply should have a ramp time $> 18 \mu s$ to ensure the slew rate $< 100 \text{mV/us}$.

Figure 6-2 describes the Power Supply Slew Rate Requirement in the device.

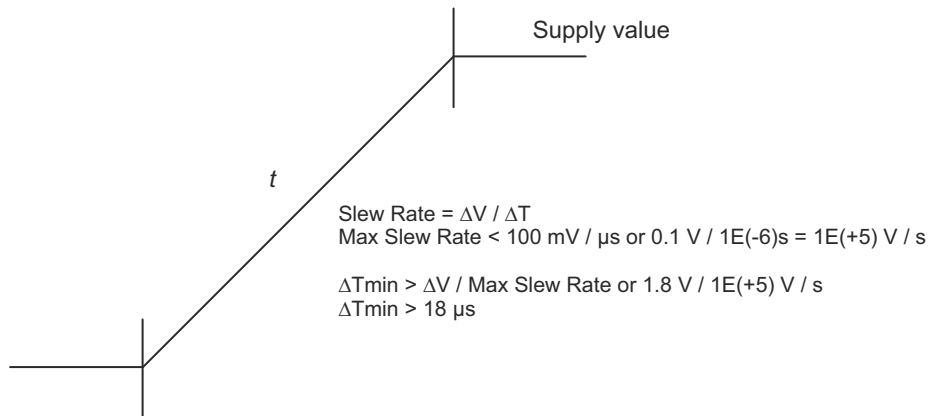
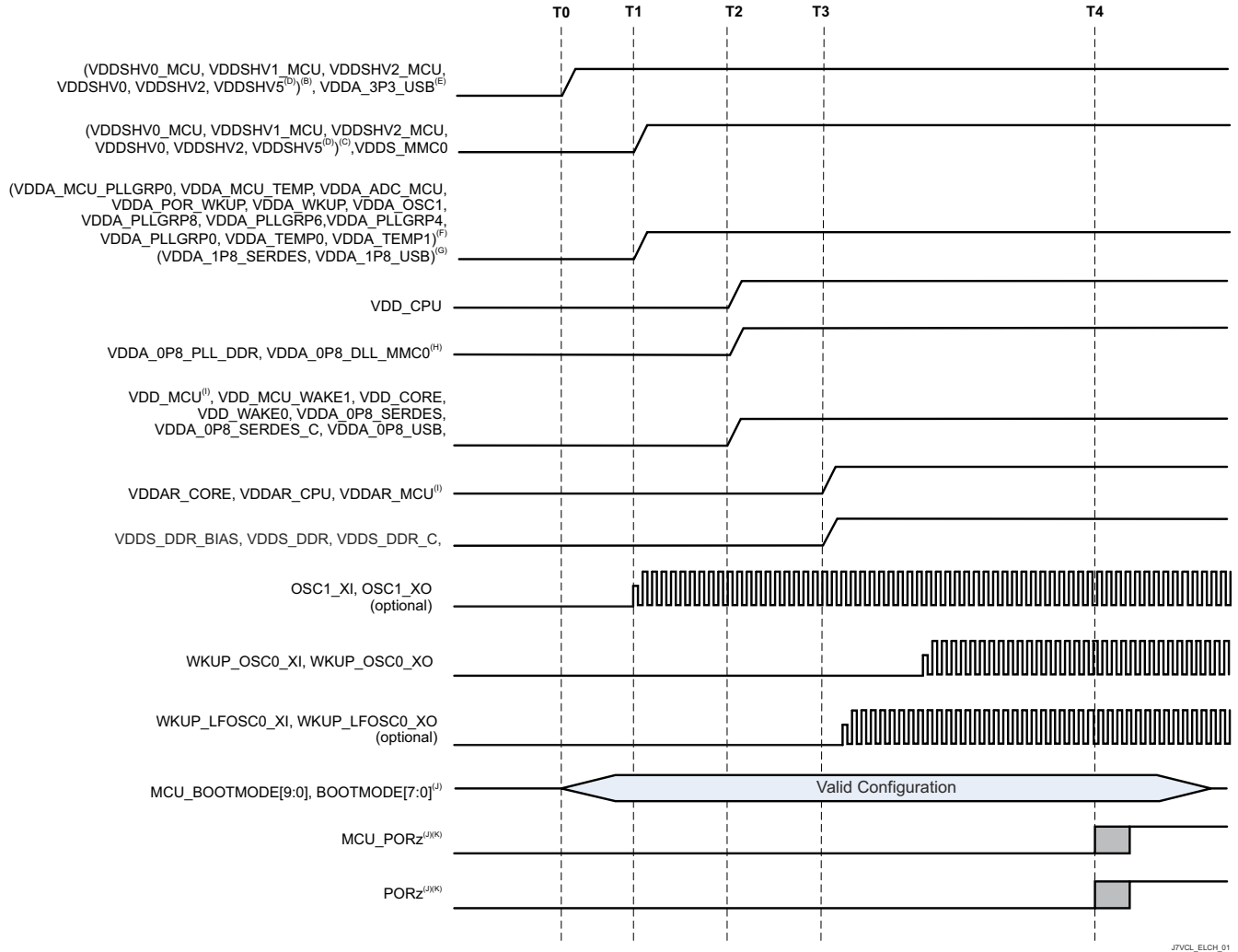

Figure 6-2. Power Supply Slew and Slew Rate

6.10.2.2 Combined MCU and Main Domains Power- Up Sequencing

Section 6.10.2.2 describes the primary power-up sequencing when similar MCU and Main voltage domains are combined into common power rails. Combining MCU and Main voltage domains simplifies PDN design by reducing total number of power rails and sources while making MCU and Main processor sub-systems operational dependent on common power rails.



J7VCL_ELCH_01

- A. Time stamp markers:
- T0 – 3.3V voltages start ramp-up to $V_{OPR\ MIN}$. (0 ms)
 - T1 – 1.8-V voltages start ramp-up to $V_{OPR\ MIN}$. (2 ms)
 - T2 – Low voltage core supplies start ramp-up to $V_{OPR\ MIN}$. (3 ms)
 - T3 – Low voltage RAM array voltages start ramp-up to $V_{OPR\ MIN}$. (4 ms)
 - T4 – OSC1 is stable and PORz/MCU_PORz are de-asserted to release processor from reset. (13 ms)
- B. Any MCU or Main dual voltage IO supplies (VDDSHVn_MCU or VDDSHVn) being supplied by 3.3V to support 3.3V digital interfaces. A few supplies could have varying start times between T0 to T1 due to PDN designs using different power resources with varying turn-on & ramp-up time delays.
- C. Any MCU or Main dual voltage IO supplies (VDDSHVn_MCU or VDDSHVn) being supplied by 1.8 V to support 1.8-V digital interfaces. When eMMC memories are used, Main 1.8-V supplies could have a ramp-up aligned to T3 due to PDN designs grouping supplies with VDD_MMC0.
- D. VDDSHV5 supports MMC1 signaling for SD memory cards. If compliant high-speed SD card operation is needed, then an independent, dual voltage (3.3 V/1.8 V) power source and rail are required. The start of ramp-up to 3.3 V will be same as other 3.3-V domains as shown. If SD card is not needed or standard data rates with fixed 3.3 V operation is acceptable, then domain can be grouped with digital IO 3.3-V power rail. If a SD card is capable of operating with fixed 1.8 V, then domain can be grouped with digital IO 1.8-V power rail.

- E. VDDA_3P3_USB is 3.3-V analog domain used for USB 2.0 differential interface signaling. A low noise, analog supply is recommended to provide best signal integrity for USB data eye mask compliance. The start of ramp-up to 3.3 V will be same as other 3.3-V domains as shown. If USB interface is not needed or data bit errors can be tolerated, then domain can be grouped with 3.3-V digital IO power rail either directly or through a supply filter.
- F. VDDA_1P8_<clk/pll/ana> are 1.8-V analog domains supporting clock oscillator, PLL and analog circuitry needing a low noise supply for optimal performance. It is not recommended to combine digital VDDSHVn_MCU and VDDSHVn IO domains since high frequency switching noise could negatively impact jitter performance of clock, PLL and DLL signals. Combining analog VDDA_1p8_<phy> domains should be avoided but if grouped, then in-line ferrite bead supply filtering is required.
- G. VDDA_1P8_<phy> are 1.8-V analog domains supporting multiple serial PHY interfaces. A low noise, analog supply is recommended to provide best signal integrity, interface performance and spec compliance. If any of these interfaces are not needed, data bit errors or non-compliant operation can be tolerated, then domains can be grouped with digital IO 1.8-V power rail either directly or through an in-line supply filter is allowed.
- H. VDDA_0P8_<dll/pll> are 0.8-V analog domains supporting PLL and DLL circuitry needing a low noise supply for optimal performance. It is not recommended to combine these domains with any other 0.8-V domains since high frequency switching noise could negatively impact jitter performance of PLL and DLL signals.
- I. VDD_MCU is a digital voltage domain with a wide operational voltage range enabling it to be grouped either with VDDAR_MCU domain or with VDD_CORE; for the “Combined MCU and Main Domains Power-Up Sequencing,” VDD_MCU can be grouped with VDD_CORE, and VDDAR_MCU can be grouped with VDDAR_CPU and VDDAR_CORE. If VDD_MCU is grouped with VDD_CORE, VDD_MCU must be ramped-up from a common voltage resource with 0.8-V VDD_CORE at T2. If VDD_MCU is not grouped with VDD_CORE, VDD_MCU must be ramped-up before T2. In either case, the VDDAR supplies must be ramped at T3.
- J. Minimum set-up and hold times shown with respect to MCU_PORz and PORz asserting high to latch MCU_BOOTMODEn (referenced to MCU_VDDSHV0) and BOOTMODEn (reference to VDDSHV2) settings into registers during power up sequence.
- K. Minimum elapsed time from crystal oscillator circuitry being energized (VDDA_OSC1 at T1) until stable clock frequency is reached depends upon on crystal oscillator, capacitor parameters and PCB parasitic values. A conservative 10 ms elapsed time defined by (T4 – T1) time stamps is shown. This could be reduced depending upon customer’s clock circuit (that is, crystal oscillator or clock generator) and PCB designs.

Figure 6-3. Combined MCU and Main Domains, Primary Power-Up Sequence

6.10.2.3 Combined MCU and Main Domains Power- Down Sequencing

Figure 6-4 describes the device power-down sequencing.

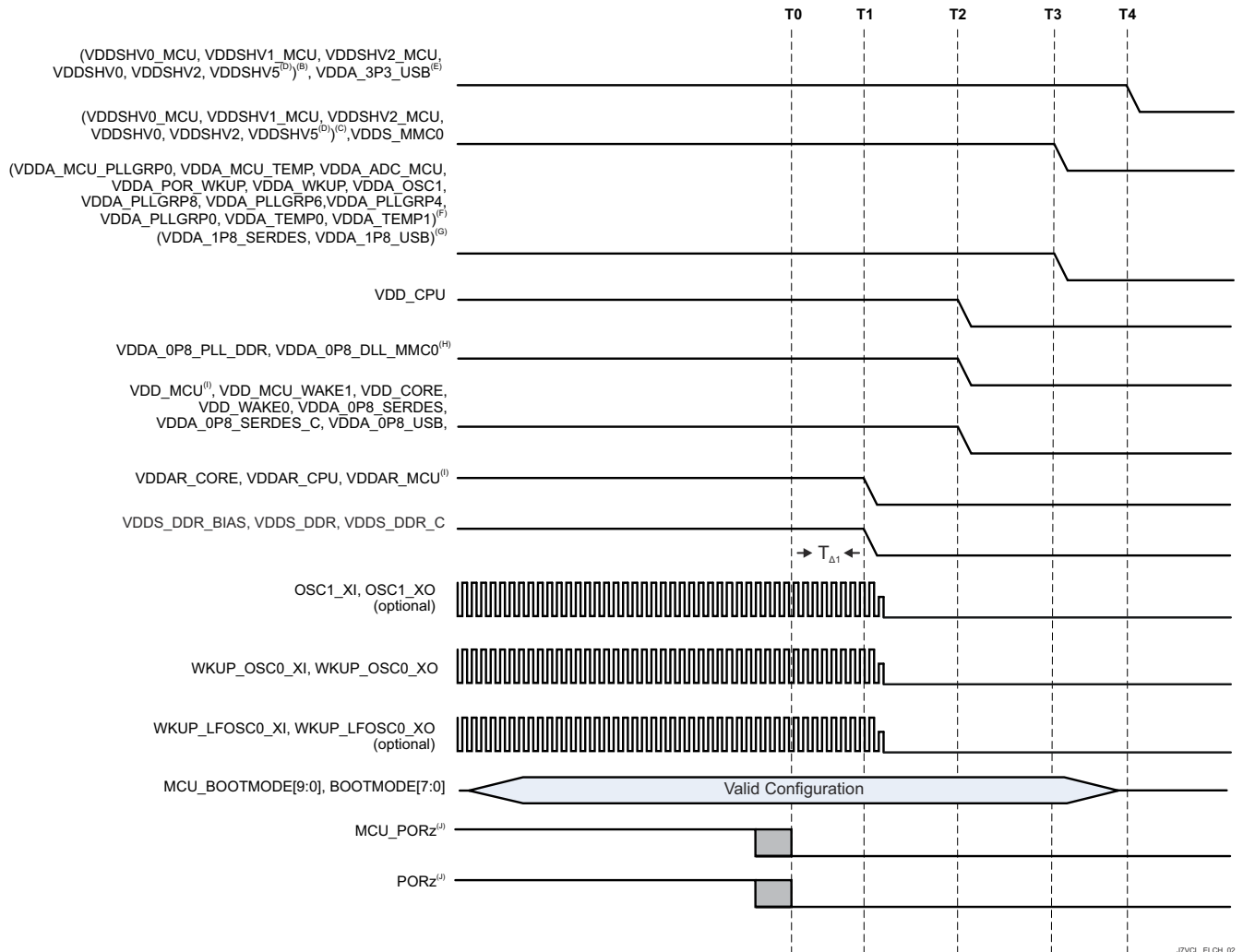

A. Time stamp markers:

- T0 – MCU_PORz & PORz assert low to put all processor resources in safe state. (0 ms)
- T1 – Main DDR, SRAM Core, and SRAM CPU power supplies start ramp-down. (0.5 ms)
- T2 – Low voltage core supplies start supply ramp-down. (2.5 ms)
- T3 – 1.8-V voltages start supply ramp-down. (3.0 ms)
- T4 – 3.3V voltages start supply ramp-down. (3.5 ms)

- B. Any MCU or Main dual voltage IO domains (VDDSHVn_MCU or VDDSHVn) being supplied by 3.3 V to support 3.3-V digital interfaces.
- C. Any MCU or Main dual voltage IO domains (VDDSHVn_MCU or VDDSHVn) being supplied by 1.8 V to support 1.8-V digital interfaces.
- D. VDDSHV5 supports MMC1 signaling for SD memory cards. A dual voltage (3.3 V/1.8 V) power rail is required for compliant, high-speed SD card operations. If SD card is not needed or standard data rates with fixed 3.3-V operation is acceptable, then domain can be grouped with digital IO 3.3-V power rail. If a SD card is capable of operating with fixed 1.8 V, then domain can be grouped with digital IO 1.8-V power rail.
- E. VDDA_3P3_USB is 3.3-V analog domain used for USB 2.0 differential interface signaling. A low noise, analog supply is recommended to provide best signal integrity for USB data eye mask compliance. If USB interface is not needed or data bit errors can be tolerated, then domain can be grouped with 3.3-V digital IO power rail either directly or through a supply filter.
- F. VDDA_1P8_<clk/pll/ana> are 1.8V analog domains supporting clock oscillator, PLL and analog circuitry needing a low noise supply for optimal performance. It is not recommended to combine digital VDDSHVn_MCU and VDDSHVn IO domains since high frequency switching noise could negatively impact jitter performance of clock, PLL and DLL signals. Combining analog VDDA_1p8_<phy> domains should be avoided but if grouped, then in-line ferrite bead supply filtering is required .

- G. VDDA_1P8_<phy> are 1.8-V analog domains supporting multiple serial PHY interfaces. A low noise, analog supply is recommended to provide best signal integrity, interface performance and spec compliance. If any of these interfaces are not needed, data bit errors or non-compliant operation can be tolerated, then domains can be grouped with digital IO 1.8-V power rail either directly or through an in-line supply filter is allowed.
- H. VDDA_0P8_<dll/pll> are 0.8-V analog domains supporting PLL and DLL circuitry needing a low noise supply for optimal performance. It is not recommended to combine these domains with any other 0.8-V domains since high frequency switching noise could negatively impact jitter performance of PLL and DLL signals.
- I. MCU_PORz and PORz must be asserted low for $T_{\Delta 1} = 200 \text{ us}$ MIN to ensure SoC resources enter into safe state before any voltage begins to ramp down.

Figure 6-4. Combined MCU and Main Domains, Primary Power-Down Sequence

6.10.2.4 Isolated MCU and Main Domains Power- Up Sequencing

Isolated MCU and Main voltage domains enable an SoC's MCU and Main processor sub-systems to operate independently. There are 2 reasons an SoC's PDN design may need to support independent MCU and Main processor functionality. First is to provide flexibility to enable SoC low power modes that can significantly reduce SoC power dissipation when processor operations are not needed. Second is to enable robustness to gain freedom from interference (FFI) of a single fault impacting both MCU and Main processor sub-systems which is especially beneficial if using the SoC's MCU as the system safety monitoring processor. The number of additional PDN power rails needed is dependent upon number of different MCU IO signaling voltage levels. If only 1.8V IO signaling is used, then only 2 additional power rails could be required. If both 1.8 and 3.3V IO signaling is desired, then 4 additional power rails could be needed.

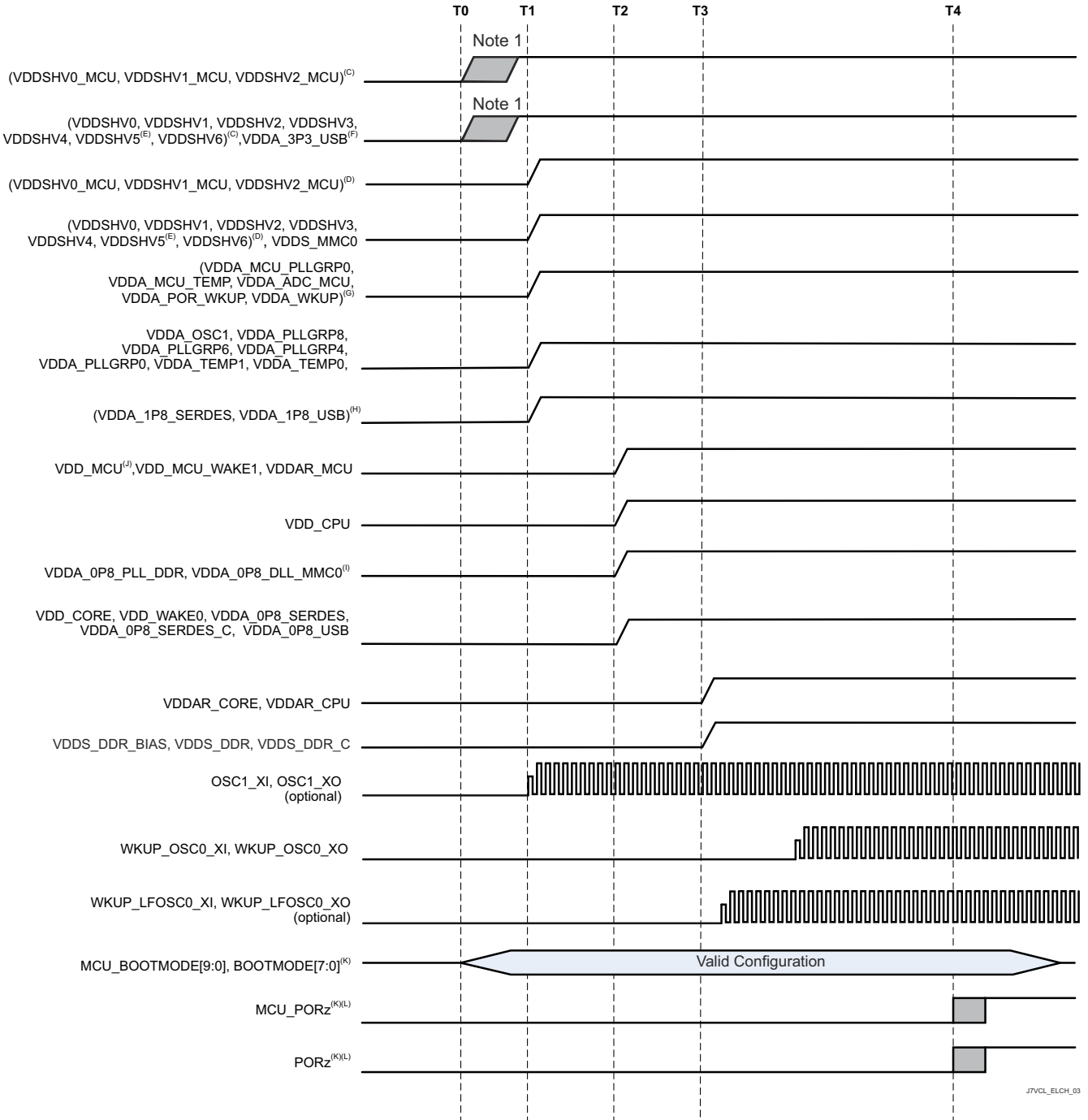

- A. T1 Time stamp markers:
- T0 – All 3.3-V voltages start supply ramp-up to $V_{OPR\ MIN}$. (0 ms)
 - T1 – All 1.8-V voltages start supply ramp-up to $V_{OPR\ MIN}$. (2 ms)
 - T2 – All core voltages start supply ramp-up to $V_{OPR\ MIN}$. (3 ms)
 - T3 – All RAM array voltages start supply ramp-up to $V_{OPR\ MIN}$. (4 ms)
 - T4 – OSC1 is stable and PORz/MCU_PORz are de-asserted to release processor from reset. (13 ms)
- B. Any MCU or Main dual voltage IO supplies (VDDSHV_n_MCU or VDDSHV_n) being supplied by 3.3 V to support 3.3-V digital interfaces. A few supplies could have varying start times between T0 to T1 due to PDN designs using different power resources with varying turn-on & ramp-up time delays.

- C. Any MCU or Main dual voltage IO supplies (VDDSHVn_MCU or VDDSHVn) being supplied by 1.8 V to support 1.8-V digital interfaces. When eMMC memories are used, Main 1.8-V supplies could have delayed start times that aligns to T3 due to PDN designs grouping supplies with VDD_MMC0.
- D. VDDSHV5 supports MMC1 signaling for SD memory cards. If compliant UHS-I SD card operation is needed, then an independent, dual voltage (3.3 V/1.8 V) power source and rail are required. The start of ramp-up to 3.3 V will be same as other 3.3-V domains as shown. If SD card is not needed or standard data rates with fixed 3.3-V operation is acceptable, then supply can be grouped with digital IO 3.3-V power rail. If a SD card is capable of operating with fixed 1.8 V, then supply can be grouped with digital IO 1.8-V power rail.
- E. VDDA_3P3_USB is 3.3-V analog supply used for USB 2.0 differential interface signaling. A low noise, analog supply is recommended to provide best signal integrity for USB data eye mask compliance. The start of ramp-up to 3.3 V will be same as other 3.3-V domains as shown. If USB interface is not needed or data bit errors can be tolerated, then supply can be grouped with 3.3-V digital IO power rail either directly or through a supply filter.
- F. VDDA_1P8_<clk/pll/ana> are 1.8-V analog domains supporting clock oscillator, PLL and analog circuitry needing a low noise supply for optimal performance. It is not recommended to combine digital VDDSHVn_MCU and VDDSHVn IO domains since high frequency switching noise could negatively impact jitter performance of clock, PLL and DLL signals. Combining analog VDDA_1p8_<phy> domains should be avoided but if grouped, then in-line ferrite bead supply filtering is required.
- G. VDDA_1P8_<phy> are 1.8-V analog domains supporting multiple serial PHY interfaces. A low noise, analog supply is recommended to provide best signal integrity, interface performance and spec compliance. If any of these interfaces are not needed, data bit errors or non-compliant operation can be tolerated, then domains can be grouped with digital IO 1.8-V power rail either directly or through an in-line supply filter is allowed.
- H. VDDA_0P8_<dll/pll> are 0.8-V analog domains supporting PLL and DLL circuitry needing a low noise supply for optimal performance. It is not recommended to combine these domains with any other 0.8-V domains since high frequency switching noise could negatively impact jitter performance of PLL and DLL signals.
- I. VDD_MCU is a digital voltage domain with a wide operational voltage range enabling it to be grouped either with VDDAR_MCU domain or with VDD_CORE; for the “Isolated MCU and Main Domains Power-Up Sequencing,” VDD_MCU can be grouped with VDDAR_MCU; VDD_MCU must be ramped-up before T2. If VDDAR_MCU is not grouped with VDD_MCU, it must be ramped at T3.
- J. Minimum set-up and hold times shown with respect to MCU_PORz and PORz asserting high to latch MCU_BOOTMODEn (referenced to MCU_VDDSHV0) and BOOTMODEn (reference to VDDSHV2) settings into registers during power up sequence.
- K. Minimum elapsed time from crystal oscillator circuitry being energized (VDDA_OSC1 at T1) until stable clock frequency is reached depends upon on crystal oscillator, capacitor parameters and PCB parasitic values. A conservative 10 ms elapsed time defined by (T4 – T1) time stamps is shown. This could be reduced depending upon customer’s clock circuit (that is, crystal oscillator or clock generator) and PCB designs.

Figure 6-5. Isolated MCU and Main Domains, Primary Power-Up Sequence

6.10.2.5 Isolated MCU and Main Domains Power- Down Sequencing

Figure 6-6 describes the device power-down sequencing.

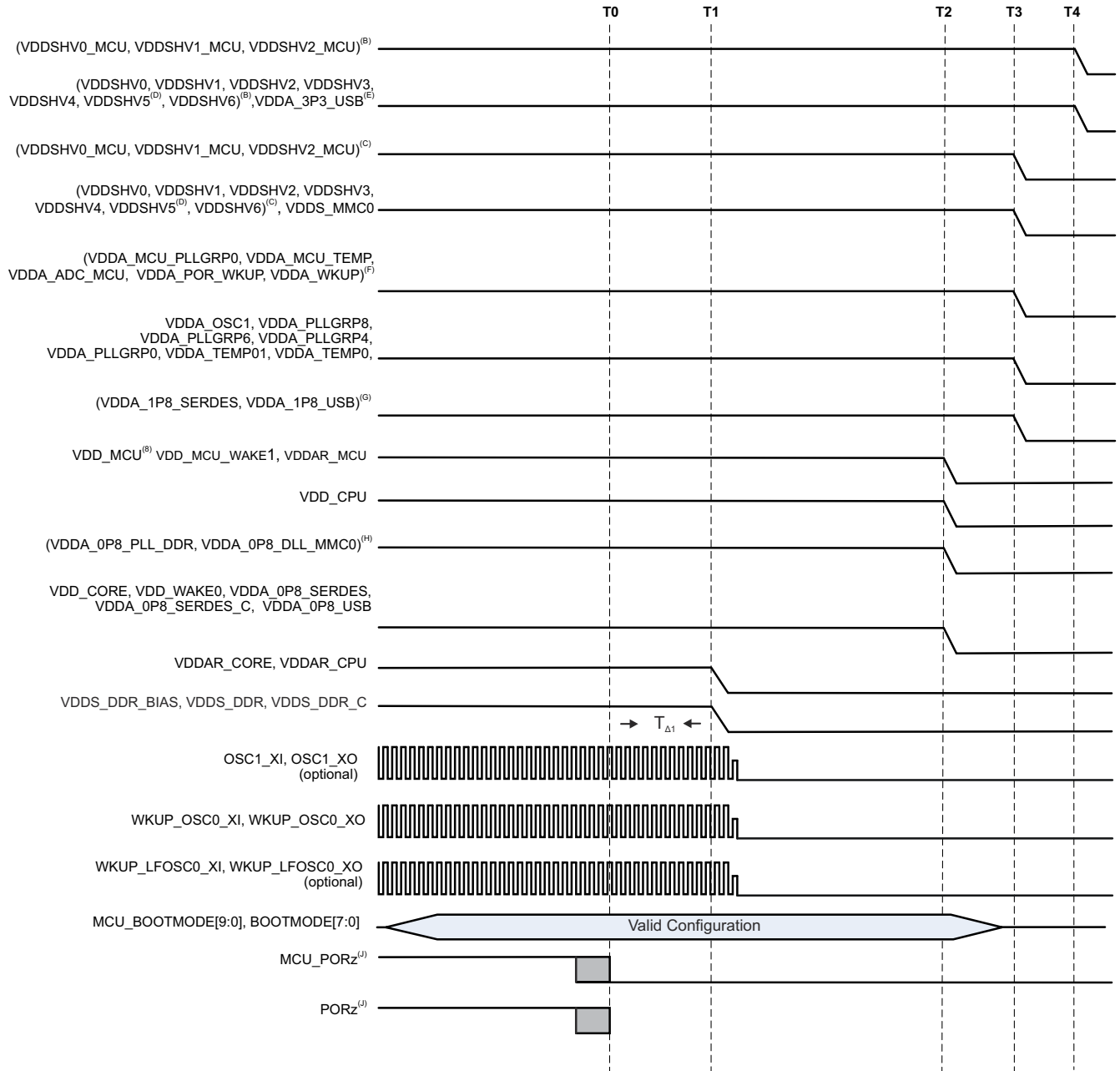

J7VCL_ELCH_04

A. Time stamp markers:

- T0 – MCU_PORz and PORz assert low to put all processor resources in safe state. (0 ms)
- T1 – Main DDR, SRAM Core, and SRAM CPU power domains start ramp-down. (0.5 ms)
- T2 – All core voltages start supply ramp-down. (2.5 ms)
- T3 – All 1.8V voltages start supply ramp-down. (3.0 ms)
- T4 – All 3.3V voltages start supply ramp-down. (3.5 ms)

B. Any MCU or Main dual voltage IO domains (VDDSHVn_MCU or VDDSHVn) being supplied by 3.3 V to support 3.3-V digital interfaces.

C. Any MCU or Main dual voltage IO supplies (VDDSHVn_MCU or VDDSHVn) being supplied by 1.8 V to support 1.8-V digital interfaces. When eMMC memories are used, Main 1.8-V supplies could have a ramp-down aligned to T1 due to PDN designs grouping supplies with VDD_MMC0.

- D. VDDSHV5 supports MMC1 signaling for SD memory cards. A dual voltage (3.3 V/1.8 V) power rail is required for compliant, high-speed SD card operations. If compliant high-speed SD card operation is needed, then an independent, dual voltage (3.3 V/1.8 V) power source and rail are required. The start of ramp-down from 3.3 V/1.8 V will be same as other 3.3-V domains as shown. If SD card is not needed or standard data rates with fixed 3.3-V operation is acceptable, then domain can be grouped with digital IO 3.3-V power rail. If a SD card is capable of operating with fixed 1.8 V, then domain can be grouped with digital IO 1.8-V power rail.
- E. VDDA_3P3_USB is 3.3-V analog domain used for USB 2.0 differential interface signaling. A low noise, analog supply is recommended to provide best signal integrity for USB data eye mask compliance. The start of ramp-down from 3.3 V will be same as other 3.3-V domains as shown. If USB interface is not needed or data bit errors can be tolerated, then domain can be grouped with 3.3-V digital IO power rail either directly or through a supply filter.
- F. VDDA_1P8_<clk/pll/ana> are 1.8-V analog domains supporting clock oscillator, PLL and analog circuitry needing a low noise supply for optimal performance. It is not recommended to combine digital VDDSHVn_MCU and VDDSHVn IO domains since high frequency switching noise could negatively impact jitter performance of clock, PLL and DLL signals. Combining analog VDDA_1p8_<phy> domains should be avoided but if grouped, then in-line ferrite bead supply filtering is required.
- G. VDDA_1P8_<phy> are 1.8-V analog domains supporting multiple serial PHY interfaces. A low noise, analog supply is recommended to provide best signal integrity, interface performance and spec compliance. If any of these interfaces are not needed, data bit errors or non-compliant operation can be tolerated, then domains can be grouped with digital IO 1.8-V power rail either directly or through an in-line supply filter is allowed.
- H. VDDA_0P8_<dll/pll> are 0.8-V analog domains supporting PLL and DLL circuitry needing a low noise supply for optimal performance. It is not recommended to combine these domains with any other 0.8-V domains since high frequency switching noise could negatively impact jitter performance of PLL and DLL signals.
- I. MCU_PORz and PORz must be asserted low for $T_{\Delta 1} = 200 \mu s$ MIN to ensure SoC resources enter into safe state before any voltage begins to ramp down.

Figure 6-6. Isolated MCU and Main Domains, Primary Power- Down Sequencing

6.10.2.6 Independent MCU and Main Domains, Entry and Exit of MCU Only Sequencing

Entry into MCU Only state is accomplished by executing a power down sequence except for the 4 MCU domains that remain energized. Exit from MCU Only state is accomplished by executing a power up sequence with the 4 MCU domains remaining energized throughout the sequ.

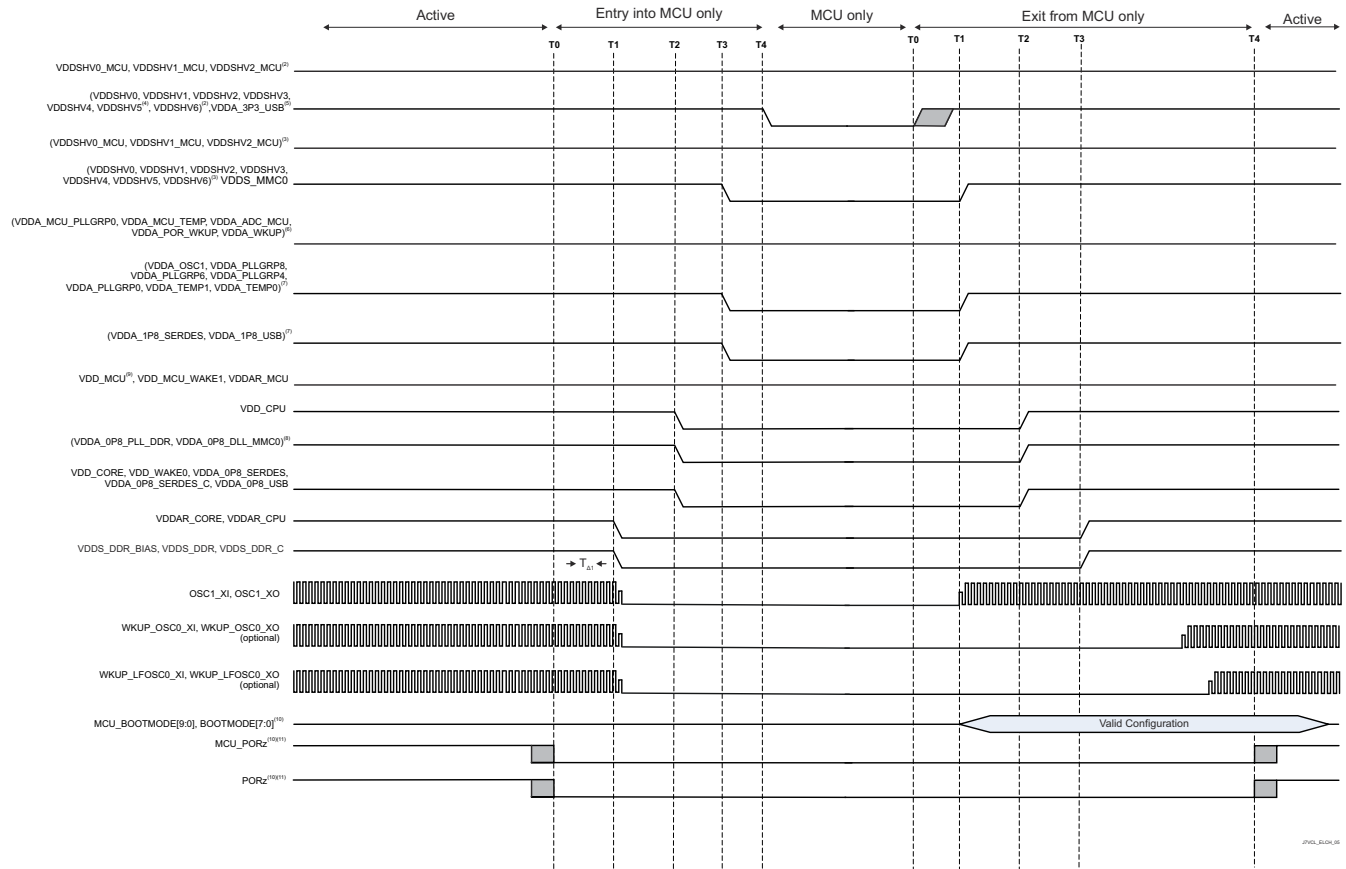

Figure 6-7. Independent MCU and Main Domains, Entry and Exit of MCU Only Sequencing

6.10.2.7 Independent MCU and Main Domains, Entry and Exit of DDR Retention State

Entry into DDR Retention state is accomplished by executing a power down sequence except for the 4 DDR domains that remain energized. Exit from DDR Retention state is accomplished by executing a power up sequence with the 3 DDR domains remaining energized throughout the sequence.

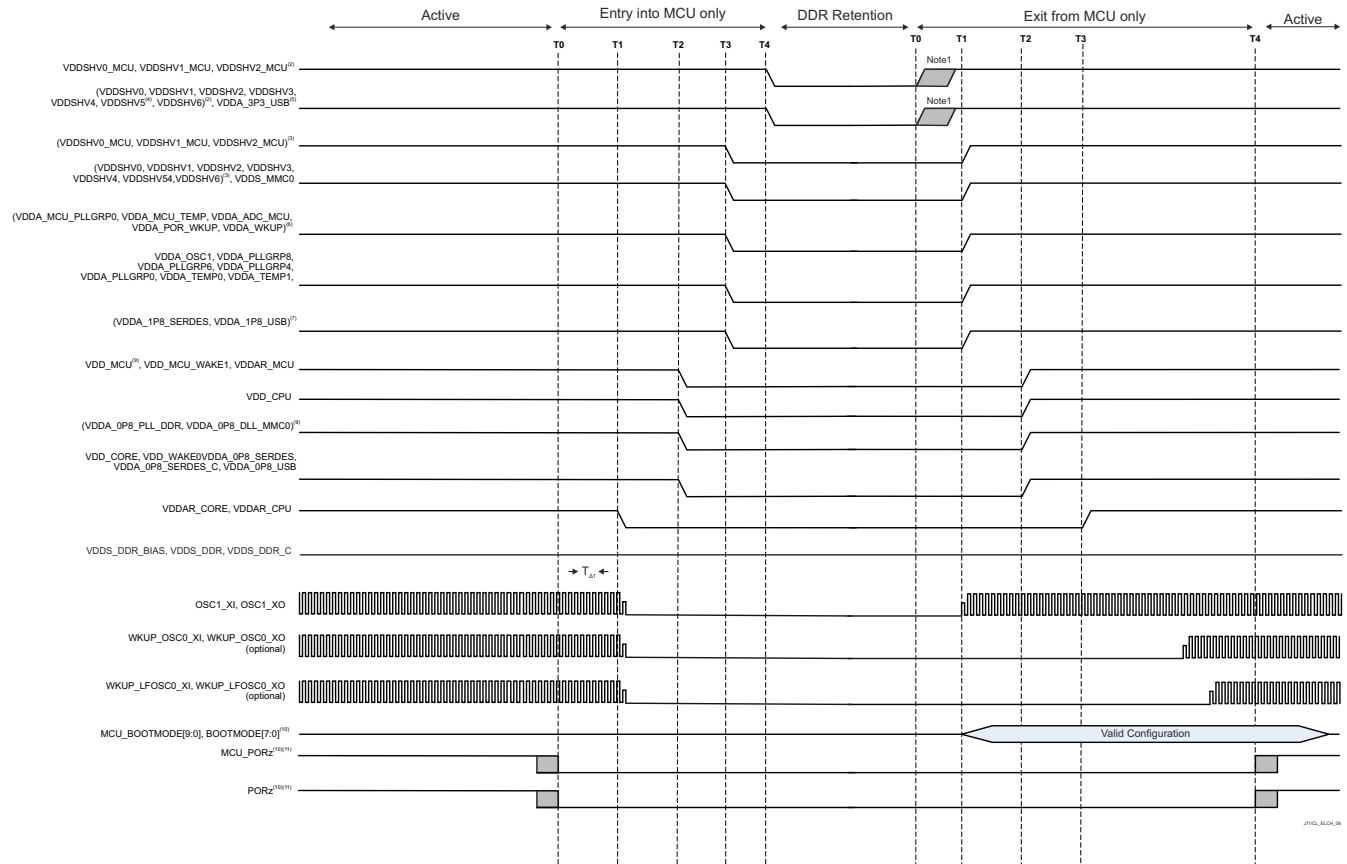

Figure 6-8. Independent MCU and Main Domains, Entry and Exit of DDR Retention State

6.10.2.8 Independent MCU and Main Domains, Entry and Exit of GPIO Retention Sequencing

Entry into GPIO Retention state is accomplished by executing a power down sequence except for the 2 or 4 wake domains that remain energized. Exit from GPIO Retention state is accomplished by executing a power up sequence with the 2 or 4 wake DDR domains remaining energized throughout the sequence.

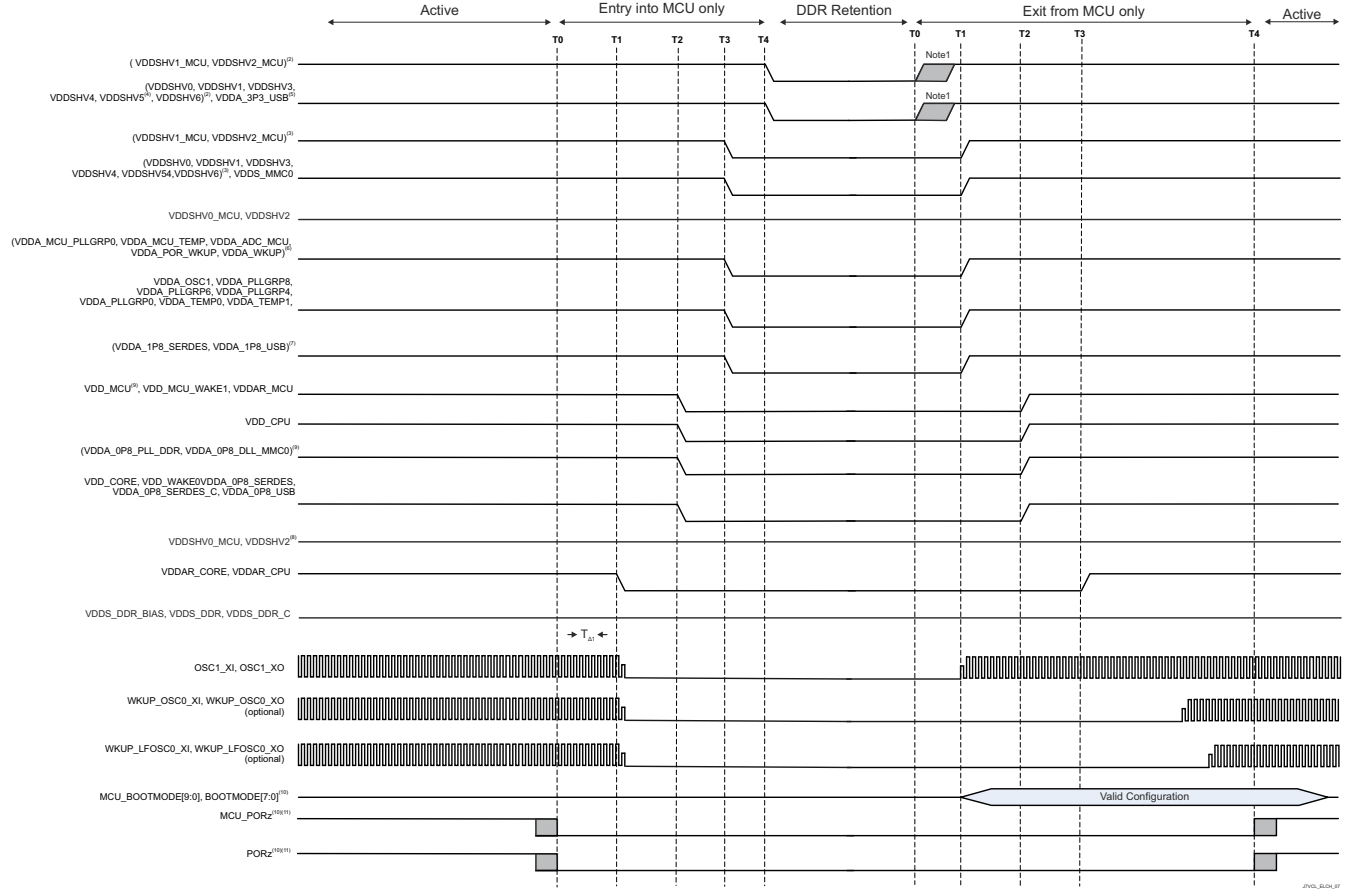

Figure 6-9. Independent MCU and Main Domains, Entry and Exit of GPIO Retention Sequencing

6.10.3 System Timing

For more details about features and additional description information on the subsystem multiplexing signals, see the corresponding sections within [Signal Descriptions](#) and *Detailed Description*.

Table 6-5. System Timing Conditions

PARAMETER		MIN	MAX	UNIT
INPUT CONDITIONS				
SR _I	Input slew rate	0.5	2	V/ns
OUTPUT CONDITIONS				
C _L	Output load capacitance	3	30	pF

6.10.3.1 Reset Timing

The tables and figures provided in this section define the timing requirements and switching characteristics for reset related signals.

Table 6-6. MCU_PORz Timing Requirements

see [Figure 6-10](#)

NO.			MIN	TYP	MAX	UNIT
RST1		Hold time, MCU_PORz active (low) at Power-up after all MCU DOMAIN supplies valid (using external crystal)	N + 1200 ⁽²⁾	9500000		ns
RST2	t _h (MCUD_SUPPLIES_VALID - MCU_PORz)	Hold time, MCU_PORz active (low) at Power-up after all MCU DOMAIN supplies ⁽¹⁾ valid and external clock stable (using external LVCMOS oscillator)	1200			ns
RST3	t _w (MCU_PORzL)	Pulse Width minimum, MCU_PORz low after Power-up (without removal of Power or system reference clock MCU_OSC0_XI/XO)	1200			ns

- (1) For the definition of the MCU DOMAIN supplies, see the [Section 6.10.2.2, Combined MCU and Main Domains Poewr-Up Sequencing](#).
- (2) N = oscillator start-up time

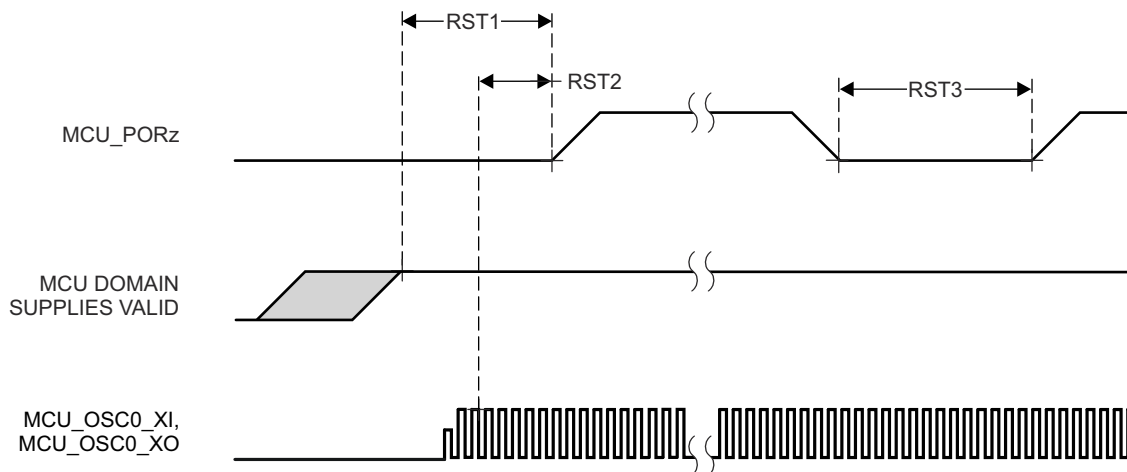

Figure 6-10. MCU_PORz Timing Requirements

Table 6-7. PORz Timing Requirements

see [Figure 6-11](#)

NO.		MIN	MAX	UNIT
RST4	$t_{h(MAIN_SUPPLIES_VALID - PORz)}$ Hold time, PORz active (low) at Power-up after all MAIN DOMAIN supplies ⁽¹⁾ valid	1200		ns
RST5	$t_{w(PORzL)}$ Pulse Width minimum, PORz low after Power-up	1200		ns

(1) For the definition of the MAIN DOMAIN supplies, see the [Section 6.10.2.2, Combined MCU and Main Domains Poewr-Up Sequencing](#).

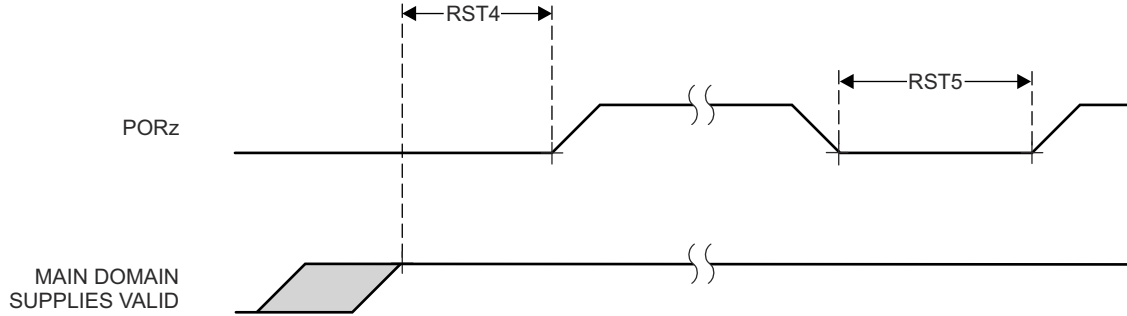

Figure 6-11. PORz Timing Requirements

Table 6-8. MCU_PORz initiates; MCU_PORz_OUT, PORz_OUT, MCU_RESETSTATz, and RESETSTATz Switching Characteristics

see [Figure 6-12](#)

NO.	PARAMETER	MODE	MIN	MAX	UNIT
RST6	$t_{d(MCU_PORzL-MCU_PORz_OUTL)}$ Delay time, MCU_PORz active (low) to MCU_PORz_OUT active (low)		0		ns
RST7	$t_{d(MCU_PORzH-MCU_PORz_OUTH)}$ Delay time, MCU_PORz inactive (high) to MCU_PORz_OUT inactive (high)		0		ns
RST8	$t_{d(MCU_PORzL-PORz_OUTL)}$ Delay time, MCU_PORz active (low) to PORz_OUT active (low)		0		ns
RST9	$t_{d(MCU_PORzH-PORz_OUTH)}$ Delay time, MCU_PORz inactive (high) to PORz_OUT inactive (high)		1500		ns
RST10	$t_{d(MCU_PORzL-MCU_RESETSTATzL)}$ Delay time, MCU_PORz active (low) to MCU_RESETSTATz active (low)		0		ns
RST11	$t_{d(MCU_PORzH-MCU_RESETSTATzH)}$ Delay time, MCU_PORz inactive (high) to MCU_RESETSTATz inactive (high)	POST bypass	12000*S ⁽¹⁾		ns
RST12	$t_{d(MCU_PORzL-RESETSTATzL)}$ Delay time, MCU_PORz active (low) to RESETSTATz active (low)		0		ns
RST13	$t_{d(MCU_PORzH-RESETSTATzH)}$ Delay time, MCU_PORz inactive (high) to RESETSTATz inactive (high)		14500*S ⁽¹⁾		ns
RST14	$t_{w(MCU_PORz_OUTL)}$ Pulse width minimum, MCU_PORz_OUT active (low)		1200		ns
RST15	$t_{w(PORz_OUTL)}$ Pulse Width Minimum PORz_OUT low		2550		ns
RST16	$t_{w(MCU_RESETSTATzL)}$ Pulse Width Minimum MCU_RESETSTATz low		3900*S ⁽¹⁾		ns
RST17	$t_{w(RESETSTATzL)}$ Pulse Width Minimum RESETSTATz low		2650*S ⁽¹⁾		ns

(1) S = MCU_OSC0_XI/XO clock period.

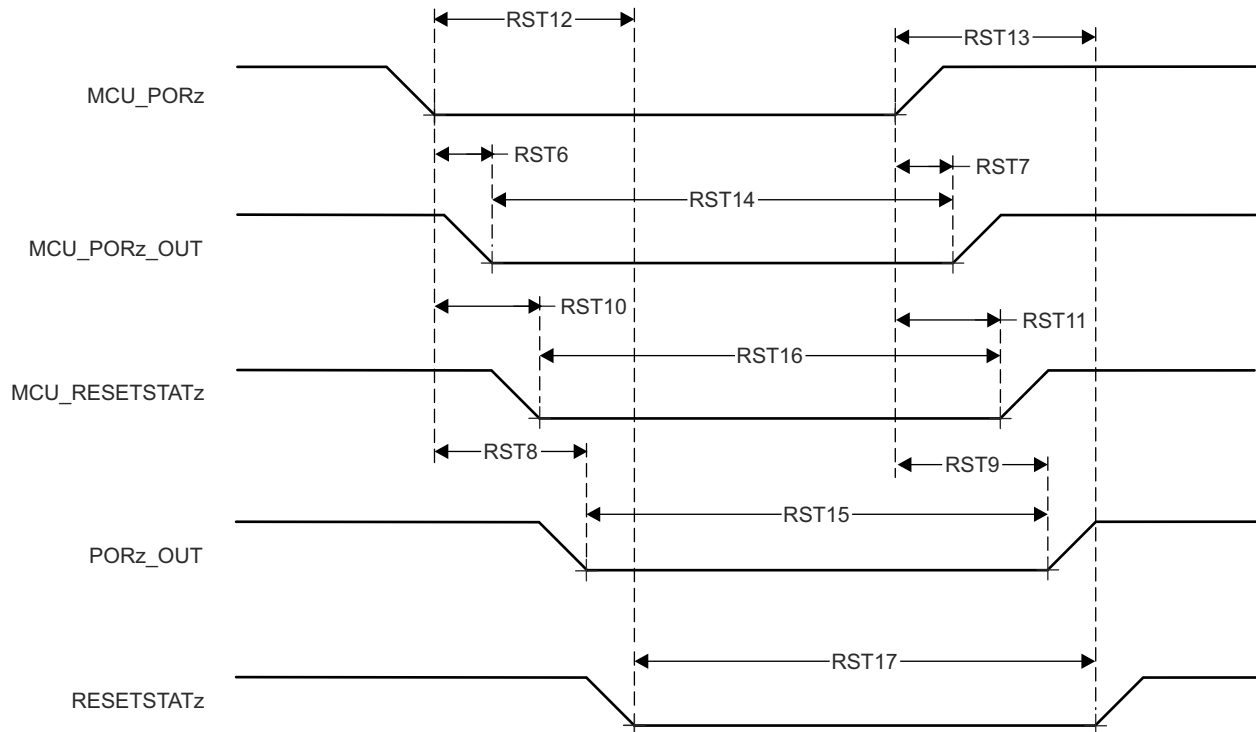

Figure 6-12. MCU_PORz initiates; MCU_PORz_OUT, PORz_OUT, MCU_RESETSTATz, and RESETSTATz Switching Characteristics

Table 6-9. PORz Initiates; PORz_OUT and RESETSTATz Switching Characteristics

see [Figure 6-13](#)

NO.	PARAMETER		MODE	MIN	MAX	UNIT
RST18	$t_{d(PORzL-PORz_OUTL)}$	Delay time, PORz active (low) toPORz_OUT active (low)	software control of POR_RST_ISO_DONE_Z	$T^{(1)}$		
			CTRLMMR_WKUP_POR_RST_CTRL[0].POR_RST_ISO_DONE_Z = 0	0		ns
RST19	$t_{d(PORzH-PORz_OUTH)}$	Delay time, PORz active (high) toPORz_OUT active (high)		1300		ns
RST20	$t_{d(PORzL-RESETSTATzL)}$	Delay time, PORz active (low) to RESETSTATz active (low)	software control of POR_RST_ISO_DONE_Z	$T^{(1)}$		
			CTRLMMR_WKUP_POR_RST_CTRL[0].POR_RST_ISO_DONE_Z = 0	0		ns
RST21	$t_{d(PORzH-RESETSTATzH)}$	Delay time, PORz active (high) to RESETSTATz active (high)		14500*S ⁽²⁾		ns

- (1) T = Reset Isolation Time (Software Dependent).
- (2) S = MCU_OSC0_XI/XO clock period.

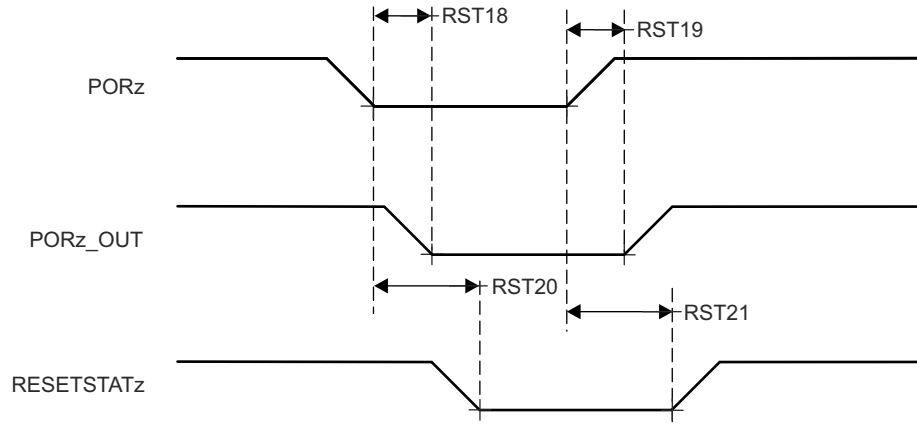

Figure 6-13. PORz initiates; PORz_OUT and RESETSTATz Switching Characteristics

Table 6-10. MCU_RESETz Timing Requirements

see [Figure 6-14](#)

NO.		MIN	MAX	UNIT
RST22	$t_{w(MCU_RESETzL)}$ ⁽¹⁾	1200		ns

(1) Timing for MCU_RESETz is valid only after all supplies are valid and MCU_PORz has been asserted for the specified time.

Table 6-11. MCU_RESETz initiates; MCU_RESETSTATz, and RESETSTATz Switching Characteristics

see [Figure 6-14](#)

NO.	PARAMETER	MIN	MAX	UNIT
RST23	$t_{d(MCU_RESETzL-MCU_RESETSTATzL)}$	800		ns
RST24	$t_{d(MCU_RESETzH-MCU_RESETSTATzH)}$	3900*S ⁽¹⁾		ns
RST25	$t_{d(MCU_RESETzL-RESETSTATzL)}$	800		ns
RST26	$t_{d(MCU_RESETzH-RESETSTATzH)}$	3900*S ⁽¹⁾		ns

(1) S = MCU_OSC0_XI/XO clock period.

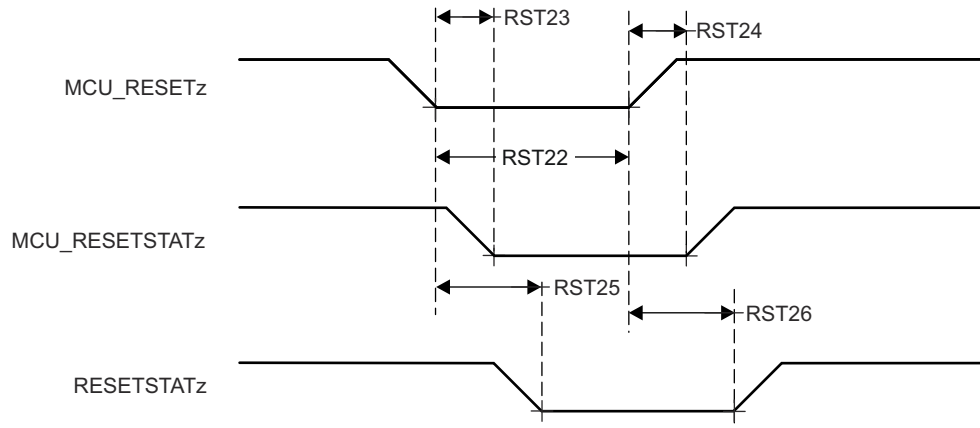

Figure 6-14. MCU_RESETz initiates; MCU_RESETSTATz, and RESETSTATz Timing Requirements and Switching Characteristics

Table 6-12. RESET_REQz Timing Requirements

see [Figure 6-15](#)

NO.		MIN	MAX	UNIT
RST27	$t_{w(RESSET_REQzL)}$ ⁽¹⁾ Pulse Width minimum, RESET_REQz active (low)	1200		ns

(1) Timing for RESET_REQz is valid only after all supplies are valid and MCU_PORz has been asserted for the specified time.

Table 6-13. RESET_REQz initiates; RESETSTATz Switching Characteristics

see [Figure 6-15](#)

NO.	PARAMETER	MODE	MIN	MAX	UNIT
RST28	$t_{d(RESSET_REQzL-RESSETSTATzL)}$ Delay time, RESET_REQz active (low) to RESETSTATz active (low)	software control of SOC_WARMRST_ISO_DONE_Z	T ⁽¹⁾		
		CTRLMMR_WKUP_MAIN_WARM_RST_CTRL[0].SOC_WARMRST_ISO_DONE_Z = 0	740		ns
RST29	$t_{d(RESSET_REQzH-RESSETSTATzH)}$ Delay time, RESET_REQz inactive (high) to RESETSTATz inactive (high)		2650*S ⁽²⁾		ns

(1) T = Reset Isolation Time (Software Dependent).

(2) S = MCU_OSC0_XI/XO clock period.

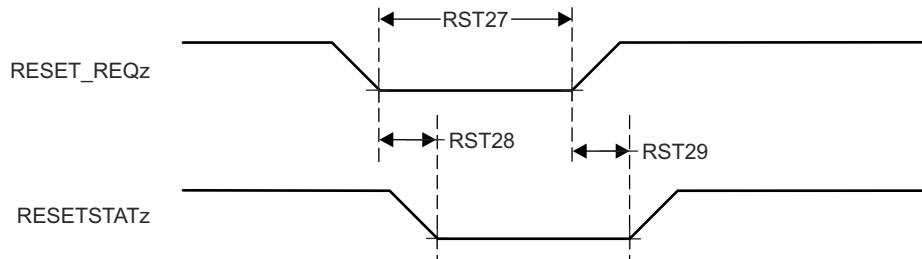

Figure 6-15. RESET_REQz initiates; RESETSTATz Timing Requirements and Switching Characteristics

Table 6-14. EMUx Timing Requirements

see [Figure 6-16](#)

NO.			MIN	MAX	UNIT
RST30	$t_{su}(EMUx-MCU_PORz)$	Setup time, EMU[1:0] before MCU_PORz inactive (high)	$3 \cdot S^{(1)}$		ns
RST31	$t_h(MCU_PORz - EMUx)$	Hold time, EMU[1:0] after MCU_PORz inactive (high)	10		ns

(1) S = MCU_OSC0_XI/XO clock period.

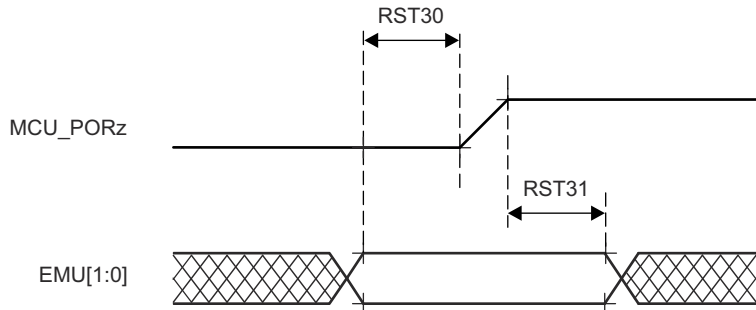

Figure 6-16. EMUx Timing Requirements

Table 6-15. MCU_BOOTMODE Timing Requirements

see [Figure 6-17](#)

NO.			MIN	MAX	UNIT
RST32	$t_{su}(MCU_BOOTMODE-MCU_PORz_OUT)$	Setup time, MCU_BOOTMODE[09:00] before MCU_PORz_OUT high	$3 \cdot S^{(1)}$		ns
RST33	$t_h(MCU_PORz_OUT - MCU_BOOTMODE)$	Hold time, MCU_BOOTMODE[09:00] after MCU_PORz_OUT high	0		ns

(1) S = MCU_OSC0_XI/XO clock period.

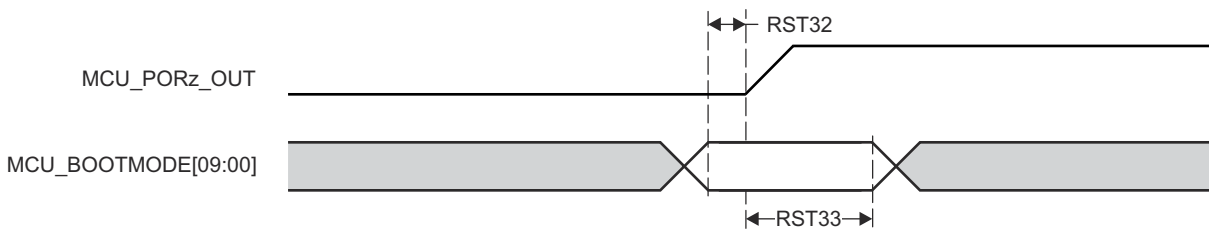

Figure 6-17. MCU_BOOTMODE Timing Requirements

Table 6-16. BOOTMODE Timing Requirements

see [Figure 6-18](#)

NO.			MIN	MAX	UNIT
RST34	$t_{su}(\text{BOOTMODE-PORz_OUT})$	Setup time, BOOTMODE[7:0] before PORz_OUT high	$3 \cdot S^{(1)}$		ns
RST35	$t_h(\text{PORz_OUT - BOOTMODE})$	Hold time, BOOTMODE[7:0] after PORz_OUT high	0		ns

(1) S = MCU_OSC0_XI/XO clock period.

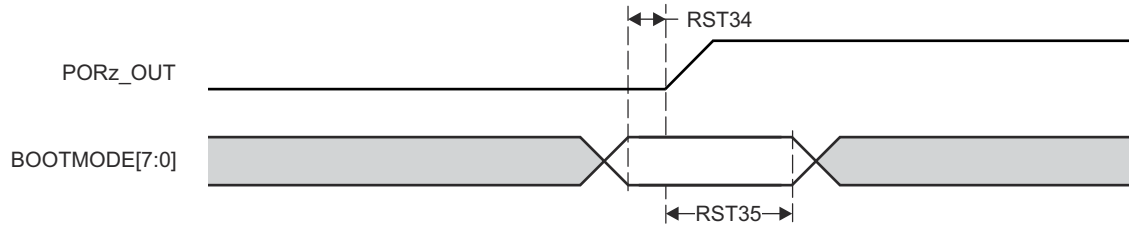

Figure 6-18. BOOTMODE Timing Requirements

6.10.3.2 Safety Signal Timing

Tables and figures provided in this section define switching characteristics for MCU_SAFETY_ERRORn and SOC_SAFETY_ERRORn.

Table 6-17. MCU_SAFETY_ERRORn Switching Characteristics

see [Figure 6-19](#)

NO.	PARAMETER	MIN	MAX	UNIT
SFTY1	$t_{w(MCU_SAFETY_ERRORn)}$ Pulse width minimum, MCU_SAFETY_ERRORn active (PWM mode disabled)	$P \cdot R^{(1) (2)}$		ns
SFTY2	$t_{d(ERROR_CONDITION-MCU_SAFETY_ERRORnL)}$ Delay time, ERROR CONDITION to MCU_SAFETY_ERRORn active	$50 \cdot P^{(1)}$		ns

- (1) P = ESM functional clock (MCU_SYCLK0 /6).
- (2) R = Error Pin Counter Pre-Load Register count value.

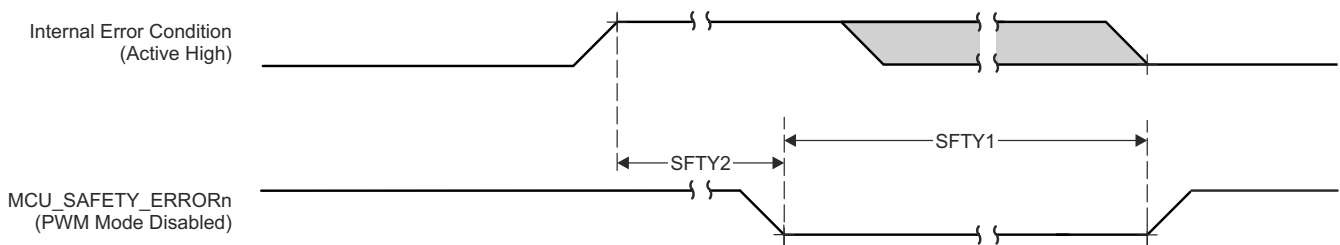

Figure 6-19. MCU_SAFETY_ERRORn Switching Characteristics

Table 6-18. SOC_SAFETY_ERRORn Switching Characteristics

see [Figure 6-20](#)

NO.	PARAMETER	MIN	MAX	UNIT
SFTY3	$t_{w(SOC_SAFETY_ERRORn)}$ Pulse width minimum, SOC_SAFETY_ERRORn active (PWM mode disabled)	$P \cdot R^{(1) (2)}$		ns
SFTY4	$t_{d(ERROR_CONDITION-SOC_SAFETY_ERRORnL)}$ Delay time, ERROR CONDITION to SOC_SAFETY_ERRORn active	$50 \cdot P^{(1)}$		ns

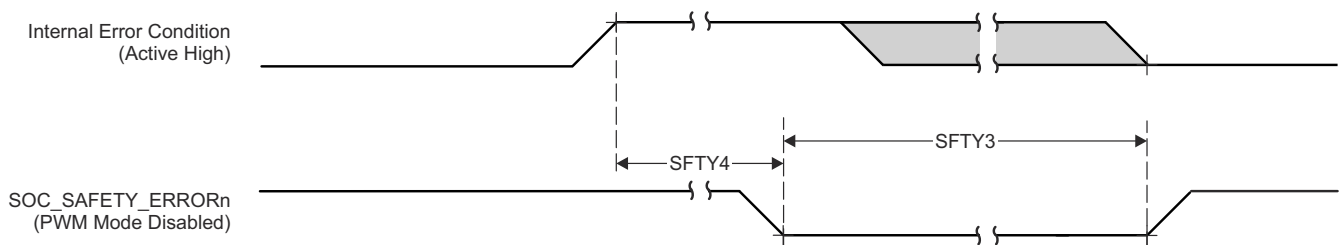

Figure 6-20. SOC_SAFETY_ERRORn Switching Characteristics

6.10.3.3 Clock Timing

Tables and figures provided in this section define timing requirements and switching characteristics for clock signals.

Table 6-19. Clock Timng Reiequiments

see [Figure 6-21](#)

NO.			MIN	MAX	UNIT
CLK1	$t_{c(EXT_REFCLK1)}$	Cycle time minimum, EXT_REFCLK1	10		ns
CLK2	$t_{w(EXT_REFCLK1H)}$	Pulse Duration minimum, EXT_REFCLK1 high	$E*0.45^{(1)}$	$E*0.55^{(1)}$	ns
CLK3	$t_{w(EXT_REFCLK1L)}$	Pulse Duration minimum, EXT_REFCLK1 low	$E*0.45^{(1)}$	$E*0.55^{(1)}$	ns

(1) E = EXT_REFCLK1 cycle time.

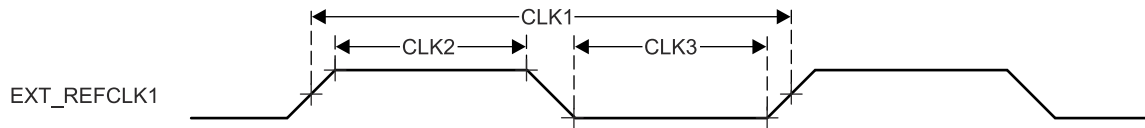

Figure 6-21. Clock Timing Requirements

Table 6-20. Clock Switching Characteristics

see [Figure 6-22](#)

NO.		PARAMETER	MIN	MAX	UNIT
CLK4	$t_{c(SYSCLKOUT0)}$	Cycle time minimum, SYSCLKOUT0	8		ns
CLK5	$t_{w(SYSCLKOUT0H)}$	Pulse Duration minimum, SYSCLKOUT0 high	$A*0.4^{(1)}$	$A*0.6^{(1)}$	ns
CLK6	$t_{w(SYSCLKOUT0L)}$	Pulse Duration minimum, SYSCLKOUT0 low	$A*0.4^{(1)}$	$A*0.6^{(1)}$	ns
CLK7	$t_{c(OBSCLK0)}$	Cycle time minimum, OBSCLK0	5		ns
CLK8	$t_{w(OBSCLK0H)}$	Pulse Duration minimum, OBSCLK0 high	$B*0.4^{(2)}$	$B*0.6^{(2)}$	ns
CLK9	$t_{w(OBSCLK0L)}$	Pulse Duration minimum, OBSCLK0 low	$B*0.4^{(2)}$	$B*0.6^{(2)}$	ns
CLK10	$t_{c(CLKOUT0)}$	Cycle time minimum, CLKOUT0	20		ns
CLK11	$t_{w(CLKOUT0H)}$	Pulse Duration minimum, CLKOUT0 high	$C*0.4^{(3)}$	$C*0.6^{(3)}$	ns
CLK12	$t_{w(CLKOUT0L)}$	Pulse Duration minimum, CLKOUT0 low	$C*0.4^{(3)}$	$C*0.6^{(3)}$	ns

(1) A = SYSCLKOUT0 cycle time.

(2) B = OBSCLK0 cycle time.

(3) C = CLKOUT0 cycle time.

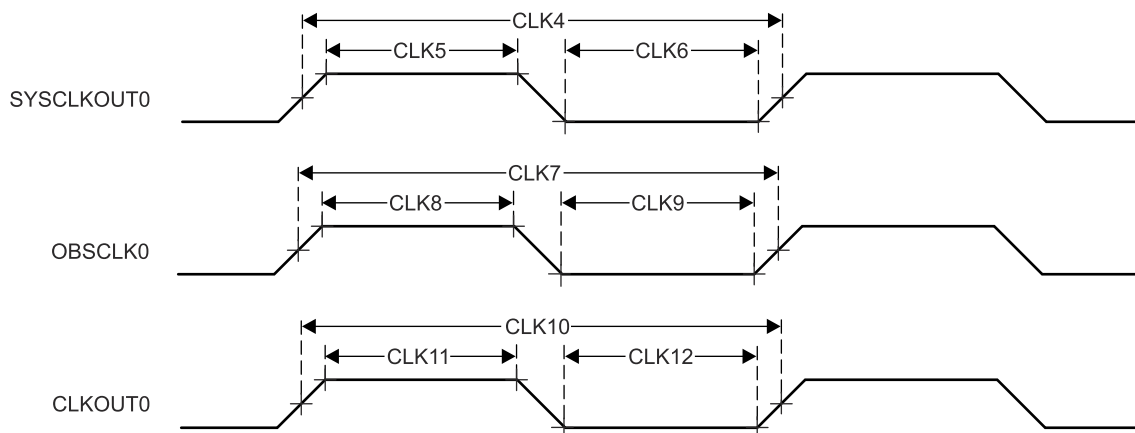

Figure 6-22. Clock Switching Characteristics

6.10.4 Clock Specifications

6.10.4.1 Input and Output Clocks / Oscillators

Various external clock inputs/outputs are needed to drive the device. Summary of these input clock signals is as follows:

- High frequency oscillators inputs
 - OSC1_XO/OSC1_XI — external main crystal interface pins connected to internal oscillator which sources reference clock. Provides reference clock to PLLs within MCU domain and MAIN domain. This high-frequency oscillator is used to provide audio clock frequencies to MCASPs.
 - WKUP_OSC0_XO/WKUP_OSC0_XI — external main crystal interface pins connected to internal oscillator which sources reference clock. Provides reference clock to PLLs within WKUP and MAIN domain.
- Low frequency digital input
 - WKUP_LF_CLKIN - Low Frequency 32k digital clock input, optionally sourced from an external PMIC or other clock source. This SoC does not support a LFOSC crystal input.
- General purpose clock inputs
 - MCU_EXT_REFCLK0 - optional external System clock input (MCU domain).
 - EXT_REFCLK1 — optional external System clock input (MAIN domain).
- Peripheral clocks - refer to the Signal Descriptions for peripheral specific clocks

For more information about Input clock interfaces, see *Clocking* section in *Device Configuration* chapter in the device TRM.

6.10.4.1.1 WKUP_OSC0 Internal Oscillator Clock Source

Figure 6-23 shows the recommended crystal circuit. All discrete components used to implement the oscillator circuit should be placed as close as possible to the WKUP_OSC0_XI and WKUP_OSC0_XO pins.

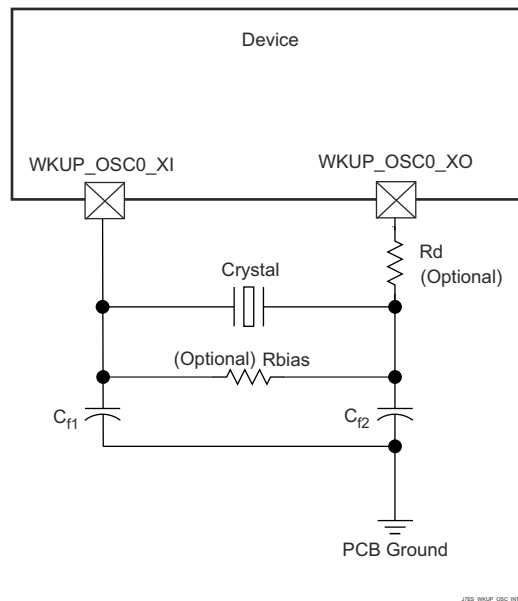

Figure 6-23. WKUP_OSC0 Crystal Implementation

The crystal must be in the fundamental mode of operation and parallel resonant. Table 6-21 summarizes the required electrical constraints.

Table 6-21. WKUP_OSC0 Crystal Electrical Characteristics

PARAMETER		MIN	TYP	MAX	UNIT
F_{xtal}	Crystal Parallel Resonance Frequency	19.2, 20, 24, 25, 26, 27			MHz

Table 6-21. WKUP_OSC0 Crystal Electrical Characteristics (continued)

PARAMETER		MIN	TYP	MAX	UNIT
F _{xtal}	Crystal Frequency Stability and Tolerance	Ethernet RGMII and RMII not used		±100	ppm
		Ethernet RGMII and RMII using derived clock		±50	
C _{L1+PCBXI}	Capacitance of C _{L1} + C _{PCBXI}	12		24	pF
C _{L2+PCBXO}	Capacitance of C _{L2} + C _{PCBXO}	12		24	pF
C _L	Crystal Load Capacitance	6		12	pF
C _{shunt}	Crystal Circuit Shunt Capacitance	ESR _{xtal} = 30 Ω	19.2 MHz, 20 MHz, 24 MHz, 25 MHz, 26 MHz, 27 MHz	7	pF
		ESR _{xtal} = 40 Ω	19.2 MHz, 20 MHz, 24 MHz, 25 MHz, 26 MHz, 27 MHz	5	pF
		ESR _{xtal} = 50 Ω	19.2 MHz, 20 MHz, 24 MHz, 25 MHz, 26 MHz, 27 MHz	5	pF
		ESR _{xtal} = 60 Ω	19.2 MHz, 20 MHz, 24 MHz	5	pF
		ESR _{xtal} = 80 Ω	19.2 MHz, 20 MHz	5	pF
			25 MHz	3	pF
ESR _{xtal} = 100 Ω	19.2 MHz, 20 MHz	3	pF		
ESR _{xtal}	Crystal Effective Series Resistance			100	Ω

When selecting a crystal, the system design must consider the temperature and aging characteristics of a based on the worst case environment and expected life expectancy of the system.

Table 6-22 details the switching characteristics of the oscillator and the requirements of the input clock.

Table 6-22. WKUP_OSC0 Switching Characteristics – Crystal Mode

PARAMETER		MIN	TYP	MAX	UNIT
C _{XI}	XI Capacitance			1.55	pF
C _{XO}	XO Capacitance			1.35	pF
C _{XIXO}	XI to XO Mutual Capacitance			0.9	fF
t _s	Maximum Start-up Time		9.5 ⁽¹⁾		ms

- (1) TI strongly encourages each customer to submit samples of the device to the resonator/crystal vendors for validation. The vendors are equipped to determine what load capacitors will best tune their resonator/crystal to the microcontroller device for optimum startup and operation over temperature/voltage extremes.

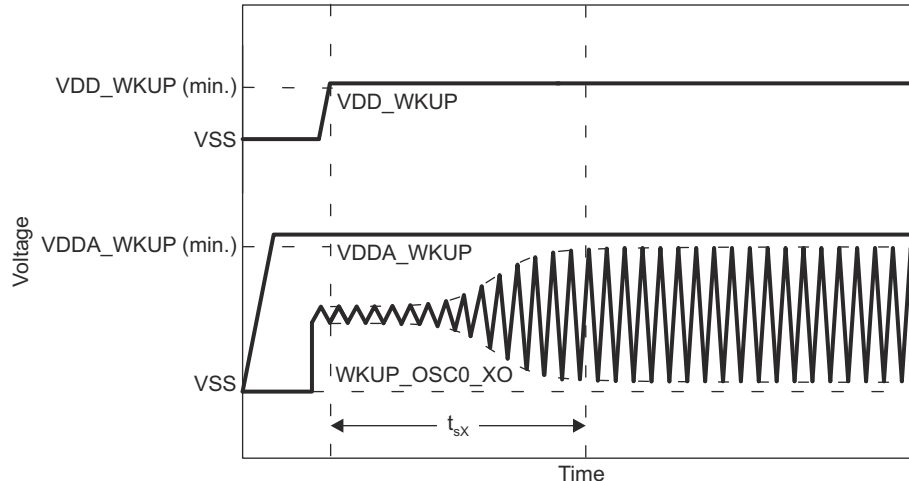

Figure 6-24. WKUP_OSC0 Start-up Time

6.10.4.1.1.1 Load Capacitance

The crystal circuit must be designed such that it applies the appropriate capacitive load to the crystal, as defined by the crystal manufacturer. The capacitive load, C_L , of this circuit is a combination of discrete capacitors C_{L1} , C_{L2} , and several parasitic contributions. PCB signal traces which connect crystal circuit components to WKUP_OSC0_XI and WKUP_OSC0_XO have parasitic capacitance to ground, C_{PCBXI} and C_{PCBXO} , where the PCB designer should be able to extract parasitic capacitance for each signal trace. The WKUP_OSC0 circuits and device package have combined parasitic capacitance to ground, C_{PCBXI} and C_{PCBXO} , where these parasitic capacitance values are defined in [Table 6-22](#).

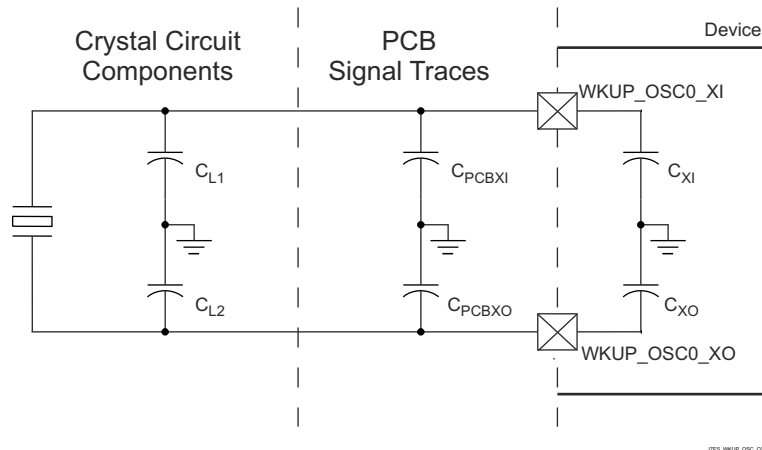

Figure 6-25. Load Capacitance

Load capacitors, C_{L1} and C_{L2} in [Figure 6-23](#), should be chosen such that the below equation is satisfied. C_L in the equation is the load specified by the crystal manufacturer.

$$C_L = [(C_{L1} + C_{PCBXI} + C_{XI}) \times (C_{L2} + C_{PCBXO} + C_{XO})] / [(C_{L1} + C_{PCBXI} + C_{XI}) + (C_{L2} + C_{PCBXO} + C_{XO})]$$

To determine the value of C_{L1} and C_{L2} , multiply the capacitive load value C_L by 2. Using this result, subtract the combined values of $C_{PCBXI} + C_{XI}$ to determine the value of C_{L1} and the combined values of $C_{PCBXO} + C_{XO}$ to determine the value of C_{L2} . For example, if $C_L = 10$ pF, $C_{PCBXI} = 2.9$ pF, $C_{XI} = 0.5$ pF, $C_{PCBXO} = 3.7$ pF, $C_{XO} = 0.5$ pF, the value of $C_{L1} = [(2C_L) - (C_{PCBXI} + C_{XI})] = [(2 \times 10 \text{ pF}) - 2.9 \text{ pF} - 0.5 \text{ pF}] = 16.6$ pF and $C_{L2} = [(2C_L) - (C_{PCBXO} + C_{XO})] = [(2 \times 10 \text{ pF}) - 3.7 \text{ pF} - 0.5 \text{ pF}] = 15.8$ pF

6.10.4.1.1.2 Shunt Capacitance

The crystal circuit must also be designed such that it does not exceed the maximum shunt capacitance for WKUP_OSC0 operating conditions defined in Table 6-21. Shunt capacitance, C_{shunt} , of the crystal circuit is a combination of crystal shunt capacitance and parasitic contributions. PCB signal traces which connect crystal circuit components to WKUP_OSC0 have mutual parasitic capacitance to each other, $C_{PCBXIXO}$, where the PCB designer should be able to extract mutual parasitic capacitance between these signal traces. The device package also has mutual parasitic capacitance, C_{XIXO} , where this mutual parasitic capacitance value is defined in Table 6-22.

PCB routing should be designed to minimize mutual capacitance between XI and XO signal traces. This is typically done by keeping signal traces short and not routing them in close proximity. Mutual capacitance can also be minimized by placing a ground trace between these signals when the layout requires them to be routed in close proximity. It is important to minimize the mutual capacitance on the PCB to provide as much margin as possible when selecting a crystal.

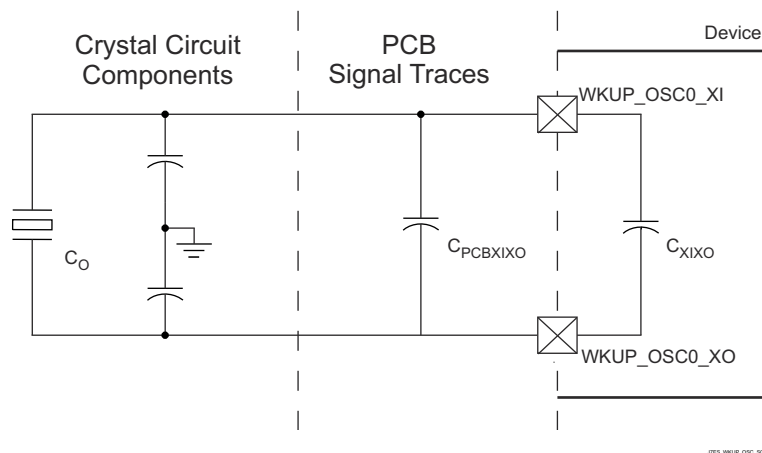

Figure 6-26. Shunt Capacitance

A crystal should be chosen such that the below equation is satisfied. C_O in the equation is the maximum shunt capacitance specified by the crystal manufacturer.

$$C_{shunt} \geq C_O + C_{PCBXIXO} + C_{XIXO}$$

For example, the equation would be satisfied when the crystal being used is 25 MHz with an ESR = 30 Ω , $C_{PCBXIXO} = 0.04$ pF, $C_{XIXO} = 0.01$ pF, and shunt capacitance of the crystal is less than or equal to 6.95 pF.

6.10.4.1.2 WKUP_OSC0 LVC MOS Digital Clock Source

Figure 6-27 shows the recommended oscillator connections when WKUP_OSC0_XI is connected to a 1.8-V LVC MOS square-wave digital clock source.

Note

A DC steady-state condition is not allowed on WKUP_OSC0_XI when the oscillator is powered up. This is not allowed because WKUP_OSC0_XI is internally AC coupled to a comparator that may enter an unknown state when DC is applied to the input. Therefore, application software should power down WKUP_OSC0 any time WKUP_OSC0_XI is not toggling between logic states.

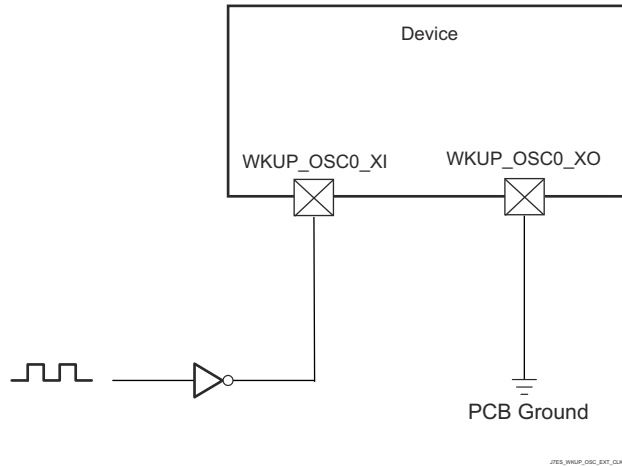

Figure 6-27. 1.8-V LVC MOS-Compatible Clock Input

6.10.4.1.3 Auxiliary OSC1 Internal Oscillator Clock Source

Figure 6-28 shows the recommended crystal circuit. All discrete components used to implement the oscillator circuit should be placed as close as possible to the OSC1_XI and OSC1_XO pins.

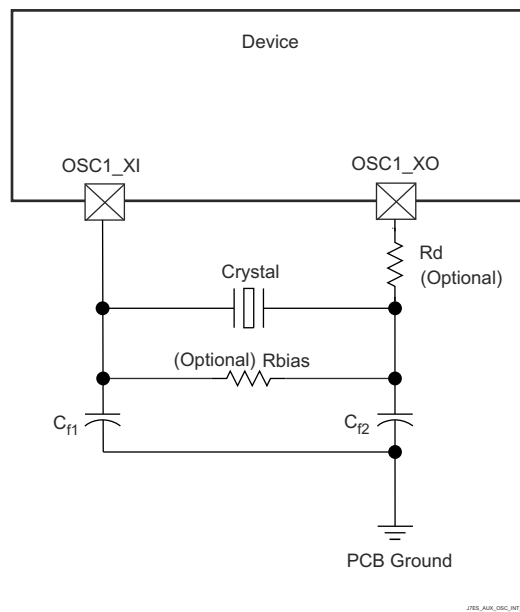

Figure 6-28. OSC1 Crystal Implementation

The crystal must be in the fundamental mode of operation and parallel resonant. [Table 6-23](#) summarizes the required electrical constraints.

Table 6-23. OSC1 Crystal Electrical Characteristics

PARAMETER		MIN	TYP	MAX	UNIT
F _{xtal}	Crystal Parallel Resonance Frequency	19.2		27	MHz
F _{xtal}	Crystal Frequency Stability and Tolerance	Ethernet RGMII and RMII not used		±100	ppm
		Ethernet RGMII and RMII using derived clock		±50	
C _{L1+PCBXI}	Capacitance of C _{L1} + C _{PCBXI}	12		24	pF
C _{L2+PCBXO}	Capacitance of C _{L2} + C _{PCBXO}	12		24	pF
C _L	Crystal Load Capacitance	6		12	pF
C _{shunt}	Crystal Circuit Shunt Capacitance	ESR _{xtal} = 30 Ω	19.2 MHz, 20 MHz, 24 MHz, 25 MHz, 26 MHz, 27 MHz	7	pF
		ESR _{xtal} = 40 Ω	19.2 MHz, 20 MHz, 24 MHz, 25 MHz, 26 MHz, 27 MHz	5	pF
		ESR _{xtal} = 50 Ω	19.2 MHz, 20 MHz, 24 MHz, 25 MHz, 26 MHz, 27 MHz	5	pF
		ESR _{xtal} = 60 Ω	19.2 MHz, 20 MHz, 24 MHz	5	pF
		ESR _{xtal} = 80 Ω	19.2 MHz, 20 MHz	5	pF
			25 MHz	3	pF
		ESR _{xtal} = 100 Ω	19.2 MHz, 20 MHz	3	pF
ESR _{xtal}	Crystal Effective Series Resistance			100	Ω

When selecting a crystal, the system design must consider the temperature and aging characteristics of a based on the worst case environment and expected life expectancy of the system.

[Table 6-24](#) details the switching characteristics of the oscillator and the requirements of the input clock.

Table 6-24. OSC1 Switching Characteristics – Crystal Mode

PARAMETER		MIN	TYP	MAX	UNIT
C _{XI}	XI Capacitance			1.55	pF
C _{XO}	XO Capacitance			1.35	pF
C _{XIXO}	XI to XO Mutual Capacitance			0.9	fF
t _s	Maximum Start-up Time		9.5 ⁽¹⁾		ms

- (1) TI strongly encourages each customer to submit samples of the device to the resonator/crystal vendors for validation. The vendors are equipped to determine what load capacitors will best tune their resonator/crystal to the microcontroller device for optimum startup and operation over temperature/voltage extremes.

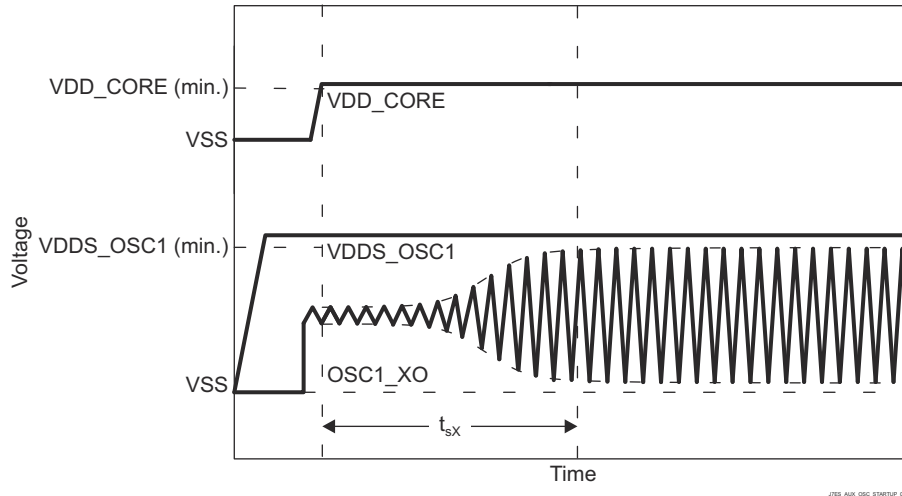

Figure 6-29. OSC1 Start-up Time

6.10.4.1.3.1 Load Capacitance

The crystal circuit must be designed such that it applies the appropriate capacitive load to the crystal, as defined by the crystal manufacturer. The capacitive load, C_L , of this circuit is a combination of discrete capacitors C_{L1} , C_{L2} , and several parasitic contributions. PCB signal traces which connect crystal circuit components to OSC1_XI and OSC1_XO have parasitic capacitance to ground, C_{PCBXI} and C_{PCBXO} , where the PCB designer should be able to extract parasitic capacitance for each signal trace. The OSC1 circuits and device package have combined parasitic capacitance to ground, C_{PCBXI} and C_{PCBXO} , where these parasitic capacitance values are defined in [Table 6-24](#).

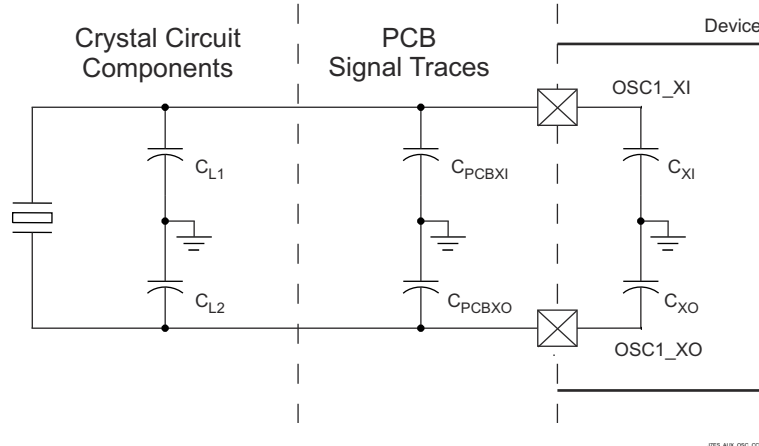

Figure 6-30. Load Capacitance

Load capacitors, C_{L1} and C_{L2} in [Figure 6-28](#), should be chosen such that the below equation is satisfied. C_L in the equation is the load specified by the crystal manufacturer.

$$C_L = [(C_{L1} + C_{PCBXI} + C_{XI}) \times (C_{L2} + C_{PCBXO} + C_{XO})] / [(C_{L1} + C_{PCBXI} + C_{XI}) + (C_{L2} + C_{PCBXO} + C_{XO})]$$

To determine the value of C_{L1} and C_{L2} , multiply the capacitive load value C_L by 2. Using this result, subtract the combined values of $C_{PCBXI} + C_{XI}$ to determine the value of C_{L1} and the combined values of $C_{PCBXO} + C_{XO}$ to determine the value of C_{L2} . For example, if $C_L = 10$ pF, $C_{PCBXI} = 2.9$ pF, $C_{XI} = 0.5$ pF, $C_{PCBXO} = 3.7$ pF, $C_{XO} = 0.5$ pF, the value of $C_{L1} = [(2C_L) - (C_{PCBXI} + C_{XI})] = [(2 \times 10 \text{ pF}) - 2.9 \text{ pF} - 0.5 \text{ pF}] = 16.6$ pF and $C_{L2} = [(2C_L) - (C_{PCBXO} + C_{XO})] = [(2 \times 10 \text{ pF}) - 3.7 \text{ pF} - 0.5 \text{ pF}] = 15.8$ pF

6.10.4.1.3.2 Shunt Capacitance

The crystal circuit must also be designed such that it does not exceed the maximum shunt capacitance for OSC1 operating conditions defined in Table 6-23. Shunt capacitance, C_{shunt} , of the crystal circuit is a combination of crystal shunt capacitance and parasitic contributions. PCB signal traces which connect crystal circuit components to OSC1 have mutual parasitic capacitance to each other, $C_{PCBXIXO}$, where the PCB designer should be able to extract mutual parasitic capacitance between these signal traces. The device package also has mutual parasitic capacitance, C_{XIXO} , where this mutual parasitic capacitance value is defined in Table 6-24.

PCB routing should be designed to minimize mutual capacitance between XI and XO signal traces. This is typically done by keeping signal traces short and not routing them in close proximity. Mutual capacitance can also be minimized by placing a ground trace between these signals when the layout requires them to be routed in close proximity. It is important to minimize the mutual capacitance on the PCB to provide as much margin as possible when selecting a crystal.

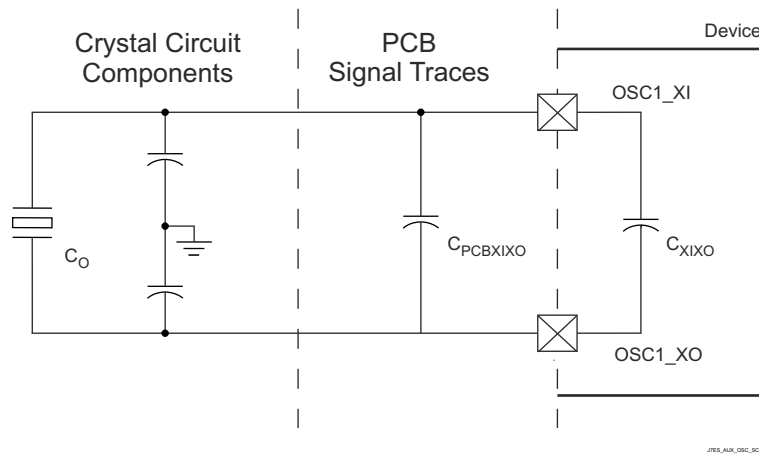

Figure 6-31. Shunt Capacitance

A crystal should be chosen such that the below equation is satisfied. C_O in the equation is the maximum shunt capacitance specified by the crystal manufacturer.

$$C_{shunt} \geq C_O + C_{PCBXIXO} + C_{XIXO}$$

For example, the equation would be satisfied when the crystal being used is 25 MHz with an ESR = 30 Ω , $C_{PCBXIXO} = 0.04$ pF, $C_{XIXO} = 0.01$ pF, and shunt capacitance of the crystal is less than or equal to 6.95 pF.

6.10.4.1.4 Auxiliary OSC1 LVCMOS Digital Clock Source

Figure 6-32 shows the recommended oscillator connections when OSC1 is connected to a 1.8-V LVCMOS square-wave digital clock source.

Note

A DC steady-state condition is not allowed on OSC1_XI when the oscillator is powered up. This is not allowed because OSC1_XI is internally AC coupled to a comparator that may enter a unknown state when DC is applied to the input. Therefore, application software should power down OSC1 any time OSC1_XI is not toggling between logic states.

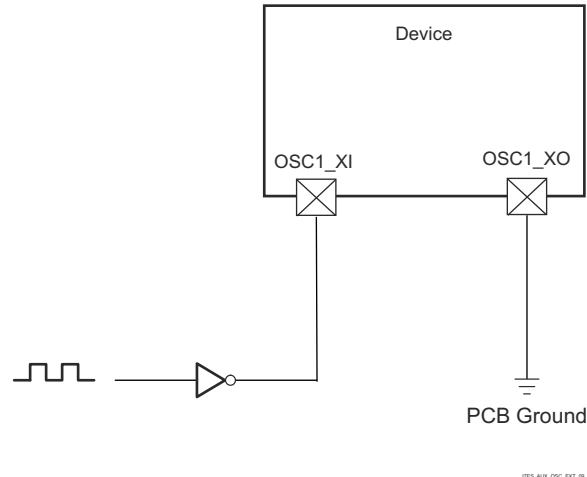

Figure 6-32. 1.8-V LVCMOS-Compatible Clock Input

6.10.4.1.5 Auxiliary OSC1 Not Used

Figure 6-33 shows the recommended oscillator connections when OSC1 is not used. OSC1_XI must be connected to VSS through an external pull resistor (R_{pd}) to ensure this input is held to a valid low level when unused since the internal pull-down resistor is disabled by default.

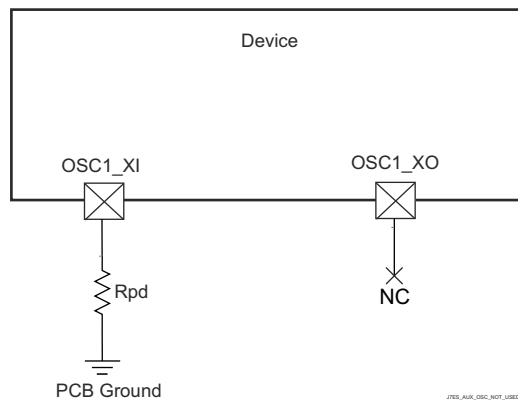

Figure 6-33. OSC1 Not Used

6.10.4.2 Output Clocks

The device provides several system clock outputs. Summary of these output clocks are as follows:

- **MCU_CLKOUT0**
 - Reference clock output for Ethernet PHYs (50 MHz or 25 MHz)
- **MCU_SYSCLKOUT0**
 - MCU_SYSCLK0 is divided by 4 and then sent out of the device as a LVCMOS clock signal (MCU_SYSCLKOUT0). This signal can be used to test if the main chip clock is functioning or not. This signal should not be used as a clock source for external devices on a board.
- **MCU_OBSCLK0**
 - On the clock output MCU_OBSCLK0, oscillators and PLLs clocks can be observed for tests and debug. This signal should not be used as a clock source for external devices on a board.
- **SYSCLKOUT0**
 - SYSCLK0 is divided by 4 and then sent out of the device as a LVCMOS clock signal (SYSCLKOUT0). This signal can be used to test if the main chip clock is functioning or not. This signal should not be used as a clock source for external devices on a board.
- **CLKOUT**

- Reference clock output for Ethernet PHYs (50 MHz)
- **OBCLK[1:0]**
 - On the clock output OBCLK0/1, oscillators and PLLs clocks can be observed for tests and debug.

6.10.4.3 PLLs

Power is supplied to the Phase-Locked Loop circuitries (PLLs) by internal regulators that derive power from the off-chip power-supply.

There are total of three PLLs in the device in WKUP and MCU domains:

- MCU_PLL0 (MCU R5FSS PLL) with WKUP_PLLCTRL0
- MCU_PLL1 (MCU PERIPHERAL PLL)
- MCU_PLL2 (MCU CPSW PLL)

There are total of twenty PLLs in the device in MAIN domain:

- PLL0 (MAIN PLL) with PLLCTRL0
- PLL1 (PER0 PLL)
- PLL2 (PER1 PLL)
- PLL3 (CPSW9G PLL)
- PLL4 (AUDIO0 PLL)
- PLL5 (VIDEO PLL)
- PLL6 (GPU PLL)
- PLL7 (C7x PLL)
- PLL8 (ARM0 PLL)
- PLL12 (DDR PLL)
- PLL13 (C66 PLL)
- PLL14 (R5F PLL)
- PLL15 (AUDIO1 PLL)
- PLL16 (DSS PLL0)
- PLL17 (DSS PLL1)
- PLL18 (DSS PLL2)
- PLL19 (DSS PLL3)
- PLL23 (DSS PLL7)
- PLL24 (MLB PLL)
- PLL25 (VISION PLL)

Note

For more information, see:

- *Device Configuration / Clocking / PLLs* section in the device TRM.
 - *Peripherals / Display Subsystem Overview* section in the device TRM.
-

Note

The input reference clock (OSC1_XI/OSC1_XO) is specified and the lock time is ensured by the PLL controller, as documented in the *Device Configuration* chapter in the device TRM.

6.10.4.4 Module and Peripheral Clocks Frequencies

[Section 6.10.5, Peripherals](#) section documents the maximum frequency associated with the peripheral clocks of the device.

For more details on the clocking structure of each module, reference *Device Configurations* chapter in the device TRM.

6.10.5 Peripherals

6.10.5.1 ATL

The device contains ATL module that can be used for asynchronous sample rate conversion of audio. The ATL calculates the error between two time bases, such as audio syncs, and optionally generates an averaged clock using cycle stealing via software.

Note

For more information about ATL, see *Audio Tracking Logic (ATL)* section in *Peripherals* chapter in the device TRM.

Table 6-25 represents ATL timing conditions.

Table 6-25. ATL Timing Conditions

PARAMETER		MODE	MIN	MAX	UNIT
INPUT CONDITIONS					
SR _I	Input slew rate	External reference CLK	0.5	5	V/ns
OUTPUT CONDITIONS					
C _L	Output load capacitance	Internal reference CLK	1	10	pF

Section 6.10.5.1.1, Section 6.10.5.1.2, Section 6.10.5.1.3, and Section 6.10.5.1.4 present timing requirements and switching characteristics for ATL.

6.10.5.1.1 ATL_PCLK Timing Requirements

NO.	PARAMETER		MODE	MIN	MAX	UNIT
D1	t _{c(pclk)}	Cycle time, ATL_PCLK	External reference CLK	5		ns
D2	t _{w(pclkL)}	Pulse Duration, ATL_PCLK low	External reference CLK	0.45 × M ⁽¹⁾ + 2.5		ns
D3	t _{w(pclkH)}	Pulse Duration, ATL_PCLK high	External reference CLK	0.45 × M ⁽¹⁾ + 2.5		ns

(1) M = ATL_CLK[x] period

6.10.5.1.2 ATL_AWS[x] Timing Requirements

NO.	PARAMETER		MODE	MIN	MAX	UNIT
D4	t _{c(aws)}	Cycle Time, ATL_AWS[x] ⁽³⁾	External reference CLK	2 × M ⁽¹⁾		ns
D5	t _{w(awsL)}	Pulse Duration, ATL_AWS[x] ⁽³⁾ low	External reference CLK	0.45 × A ⁽²⁾ + 2.5		ns
D6	t _{w(awsH)}	Pulse Duration, ATL_AWS[x] ⁽³⁾ high	External reference CLK	0.45 × A ⁽²⁾ + 2.5		ns

(1) M = ATL_CLK[x] period

(2) A = ATL_AWS[x] period

(3) x = 0 to 3

6.10.5.1.3 ATL_BWS[x] Timing Requirements

NO.	PARAMETER		MODE	MIN	MAX	UNIT
D7	t _{c(bws)}	Cycle Time, ATL_BWS[x] ⁽³⁾	External reference clock	2 × M ⁽¹⁾		ns
D8	t _{w(bwsL)}	Pulse Duration, ATL_BWS[x] low ⁽³⁾	External reference clock	0.45 × B ⁽²⁾ + 2.5		ns

NO.			MODE	MIN	MAX	UNIT
D9	$t_{w(bwsH)}$	Pulse Duration, ATCL_BWS[x] high ⁽³⁾	External reference clock	$0.45 \times B^{(2)} + 2.5$		ns

- (1) M = ATCL_CLK[x] period
 (2) B = ATCL_BWS[x] period
 (3) x = 0 to 3

6.10.5.1.4 ATCLK[x] Switching Characteristics

NO.	PARAMETER		MODE	MIN	MAX	UNIT
D10	$t_{c(atclk)}$	Cycle time, ATCLK[x] ⁽³⁾	Internal reference CLK	20		ns
D11	$t_{w(atclkL)}$	Pulse Duration, ATCLK[x] low ⁽³⁾	Internal reference CLK	$0.45 \times P^{(2)} - M^{(1)} - 0.3$		ns
D12	$t_{w(atclkH)}$	Pulse Duration, ATCLK[x] high ⁽³⁾	Internal reference CLK	$0.45 \times P^{(2)} - M^{(1)} - 0.3$		ns

- (1) M = ATCL_CLK[x] period
 (2) P = ATCLK[x] period
 (3) x = 0 to 3

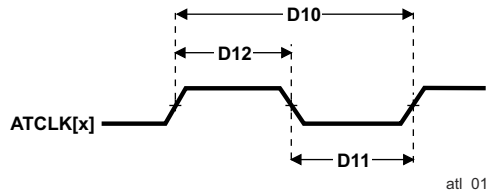

Figure 6-34. ATCLK[x] Timing

6.10.5.2 CPSW2G

For more details about features and additional description information on the device Gigabit Ethernet MAC, see the corresponding sections within [Signal Descriptions](#) and *Detailed Description*.

6.10.5.2.1 CPSW2G MDIO Interface Timings

Table 6-26 represents CPSW2G timing conditions.

Table 6-26. CPSW2G MDIO Timing Conditions

PARAMETER	DESCRIPTION	MIN	MAX	UNIT
INPUT CONDITIONS				
SR _I	Input signal slew rate	0.9	3.6	V/ns
OUTPUT CONDITIONS				
C _L	Output load capacitance	10	470	pF

Table 6-27, Table 6-28, and Figure 6-35 present timing requirements for MDIO.

Table 6-27. CPSW2G MDIO Timing Requirements

NO.	PARAMETER	DESCRIPTION	MIN	MAX	UNIT
MDIO1	t _{su(mdioV-mdcH)}	Setup time, MDIO[x]_MDIO valid before MDIO[x]_MDC high	90		ns
MDIO2	t _{h(mdcH-mdioV)}	Hold time, MDIO[x]_MDIO valid after MDIO[x]_MDC high	0		ns

Table 6-28. CPSW2G MDIO Switching Characteristics

NO.	PARAMETER	DESCRIPTION	MIN	MAX	UNIT
MDIO3	t _{c(mdc)}	Cycle time, MDIO[x]_MDC	400		ns
MDIO4	t _{w(mdcH)}	Pulse Duration, MDIO[x]_MDC high	160		ns
MDIO5	t _{w(mdcL)}	Pulse Duration, MDIO[x]_MDC low	160		ns
MDIO7	t _{d(mdcL-mdioV)}	Delay time, MDIO[x]_MDC low to MDIO[x]_MDIO valid	-150	150	ns

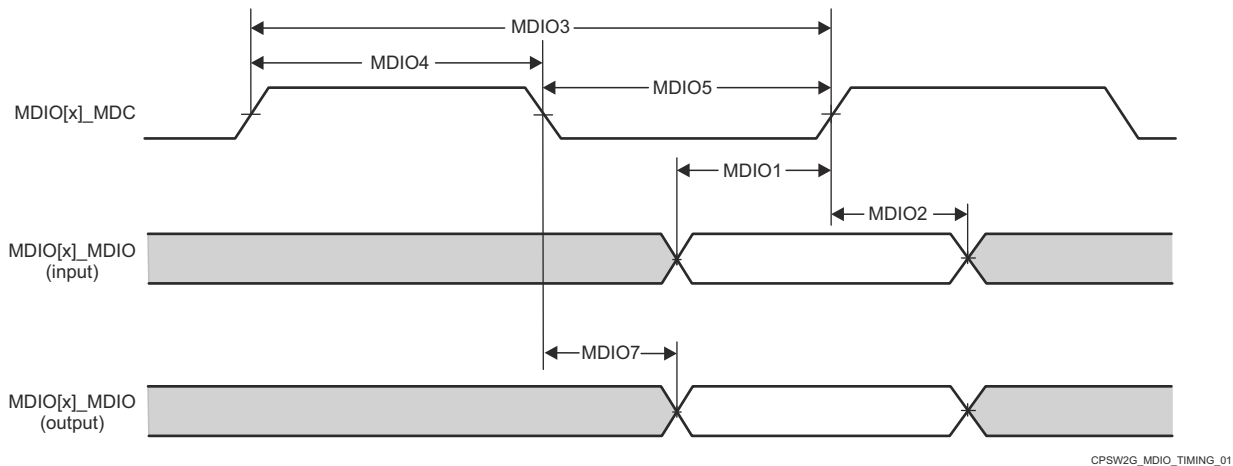

CPSW2G_MDIO_TIMING_01

Note

x = 0 in MCU domain

Figure 6-35. CPSW2G MDIO Timing Requirements and Switching Characteristics

6.10.5.2.2 CPSW2G RMII Timings

Table 6-29, Section 6.10.5.2.2.1, Section 6.10.5.2.2.2, and Section 6.10.5.2.2.3 present timing conditions, requirements, and switching characteristics for CPSW2G RMII.

Table 6-29. CPSW2G RMII Timing Conditions

PARAMETER		MIN	MAX	UNIT	
INPUT CONDITIONS					
SR _I	Input signal slew rate	VDD ⁽¹⁾ = 1.8 V	0.108	0.54	V/ns
		VDD ⁽¹⁾ = 3.3 V	0.4	1.2	V/ns
OUTPUT CONDITIONS					
C _L	Output load capacitance	3	25	pF	

(1) VDD stands for corresponding power supply. For more information on the power supply name and the corresponding ball(s), see POWER column of the [Pin Attributes](#)

6.10.5.2.2.1 CPSW2G RMII[x]_REF_CLK Timing Requirements – RMII Mode

see [Figure 6-36](#)

NO.			MIN	MAX	UNIT
RMII1	t _{c(ref_clk)}	Cycle time, RMII[x]_REF_CLK	19.999	20	ns
RMII2	t _{w(ref_clkH)}	Pulse Duration, RMII[x]_REF_CLK high	7	13	ns
RMII3	t _{w(ref_clkL)}	Pulse Duration, RMII[x]_REF_CLK low	7	13	ns

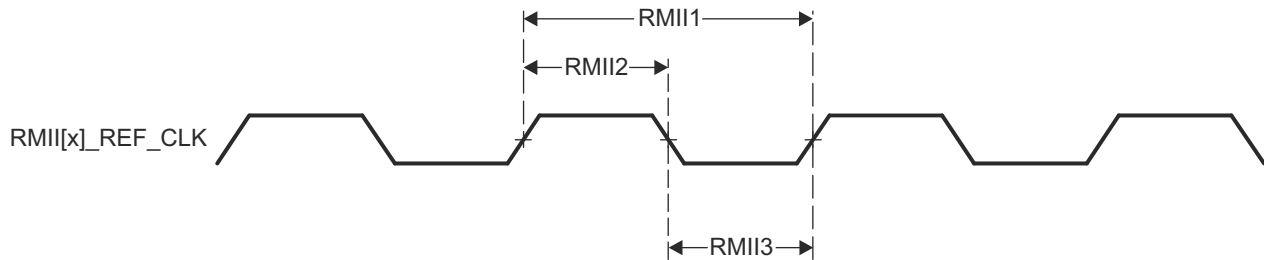

A. x = 1 in MCU domain.

Figure 6-36. CPSW2G RMII[x]_REFCLK Timing Requirements – RMII Mode

6.10.5.2.2.2 CPSW2G RMII[x]_RXD[1:0], RMII[x]_CRS_DV, and RMII[x]_RX_ER Timing Requirements – RMII Mode

NO.			MIN	MAX	UNIT
RMII4	t _{su(rxdV-ref_clkH)}	Setup time, RMII[x]_RXD[1:0] valid before RMII[x]_REF_CLK rising edge	4		ns
	t _{su(crs_dvV-ref_clkH)}	Setup time, RMII[x]_CRS_DV valid before RMII[x]_REF_CLK rising edge	4		ns
	t _{su(rx_erV-ref_clkH)}	Setup time, RMII[x]_RX_ER valid before RMII[x]_REF_CLK rising edge	4		ns
RMII5	t _{h(ref_clkH-rxdV)}	Hold time, RMII[x]_RXD[1:0] valid after RMII[x]_REF_CLK rising edge	2		ns
	t _{h(ref_clkH-crs_dvV)}	Hold time, RMII[x]_CRS_DV valid after RMII[x]_REF_CLK rising edge	2		ns
	t _{h(ref_clkH-rx_erV)}	Hold time, RMII[x]_RX_ER valid after RMII[x]_REF_CLK rising edge	2		ns

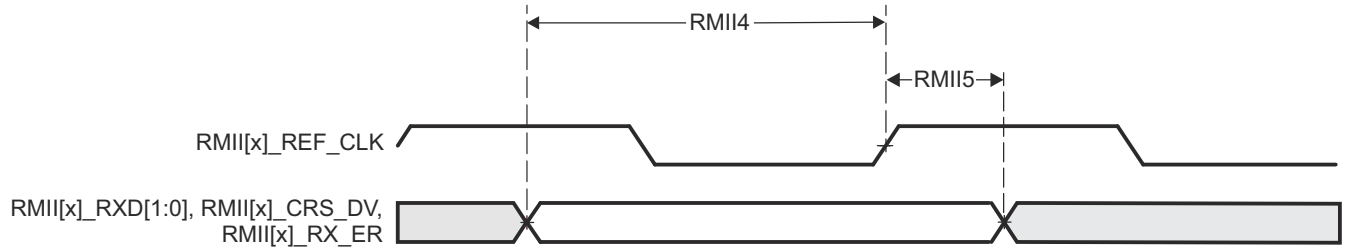

Figure 6-37. CPSW2G RMII[x]_RXD[1:0], RMII[x]_CRS_DV, RMII[x]_RX_ER Timing Requirements – RMII Mode

Section 6.10.5.2.2.3, and Figure 6-38 present switching characteristics for CPSW2G RMII Transmit.

6.10.5.2.2.3 CPSW2G RMII[x]_TXD[1:0], and RMII[x]_TX_EN Switching Characteristics – RMII Mode

see Figure 6-38

NO.	PARAMETER		MIN	MAX	UNIT
RMII6	$t_{d(\text{ref_clkH-txdV})}$	Delay time, RMII[x]_REF_CLK rising edge to RMII[x]_TXD[1:0] valid	2	10	ns
	$t_{d(\text{ref_clkH-tx_enV})}$	Delay time, RMII[x]_REF_CLK rising edge to RMII[x]_TX_EN valid	2	10	ns

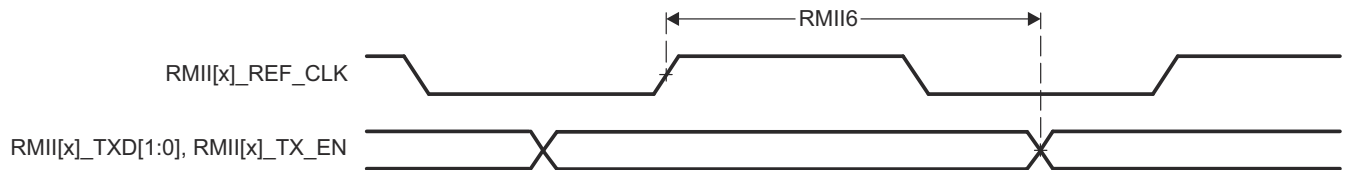

Figure 6-38. RMII[x]_TXD[1:0], and RMII[x]_TX_EN Switching Characteristics – RMII Mode

6.10.5.2.3 CPSW2G RGMII Timings

Section 6.10.5.2.3.1, Section 6.10.5.2.3.2, and Figure 6-40 present timing requirements for receive RGMII operation.

For more information, see *Gigabit Ethernet MAC (MCU_CPSW0)* section in *Peripherals* chapter in the device TRM.

Table 6-30. CPSW2G RGMII Timing Conditions

PARAMETER		MIN	MAX	UNIT
INPUT CONDITIONS				
SR _i	Input slew rate	VDD ⁽¹⁾ = 1.8 V	1.44	5 V/ns
		VDD ⁽¹⁾ = 3.3 V	2.64	5 V/ns
OUTPUT CONDITIONS				
C _L	Output load capacitance	2	20	pF
PCB CONNECTIVITY REQUIREMENTS				
t _d (Trace Mismatch Delay)	Propagation delay mismatch across all traces	RGMII[x]_RXC, RGMII[x]_RD[3:0], RGMII[x]_RX_CTL	50	ps
		RGMII[x]_TXC, RGMII[x]_TD[3:0], RGMII[x]_TX_CTL	50	ps

(1) VDD stands for corresponding power supply. For more information on the power supply name and the corresponding ball(s), see POWER column of the [Pin Attributes](#).

6.10.5.2.3.1 RGMII[x]_RXC Timing Requirements – RGMII Mode

see [Figure 6-39](#)

NO.			MODE	MIN	MAX	UNIT
RGMII1	$t_{c(rx)}$	Cycle time, RGMII[x]_RXC	10Mbps	360	440	ns
			100Mbps	36	44	ns
			1000Mbps	7.2	8.8	ns
RGMII2	$t_{w(rxch)}$	Pulse duration, RGMII[x]_RXC high	10Mbps	160	240	ns
			100Mbps	16	24	ns
			1000Mbps	3.6	4.4	ns
RGMII3	$t_{w(rxcl)}$	Pulse duration, RGMII[x]_RXC low	10Mbps	160	240	ns
			100Mbps	16	24	ns
			1000Mbps	3.6	4.4	ns

6.10.5.2.3.2 CPSW2G Timing Requirements for RGMII[x]_RD[3:0], and RGMII[x]_RCTL – RGMII Mode

see [Figure 6-39](#)

NO.			MODE	MIN	MAX	UNIT
RGMII4	$t_{su(rdV-rxcV)}$	Setup time, RGMII[x]_RD[3:0] valid before RGMII[x]_RXC transition	10Mbps	1		ns
			100Mbps	1		ns
			1000Mbps	1		ns
	$t_{su(rx_ctlV-rxcV)}$	Setup time, RGMII[x]_RX_CTL valid before RGMII[x]_RXC transition	10Mbps	1		ns
			100Mbps	1		ns
			1000Mbps	1		ns
RGMII5	$t_{h(rxV-rdV)}$	Hold time, RGMII[x]_RD[3:0] valid after RGMII[x]_RXC transition	10Mbps	1		ns
			100Mbps	1		ns
			1000Mbps	1		ns
	$t_{h(rxV-rx_ctlV)}$	Hold time, RGMII[x]_RX_CTL valid after RGMII[x]_RXC transition	10Mbps	1		ns
			100Mbps	1		ns
			1000Mbps	1		ns

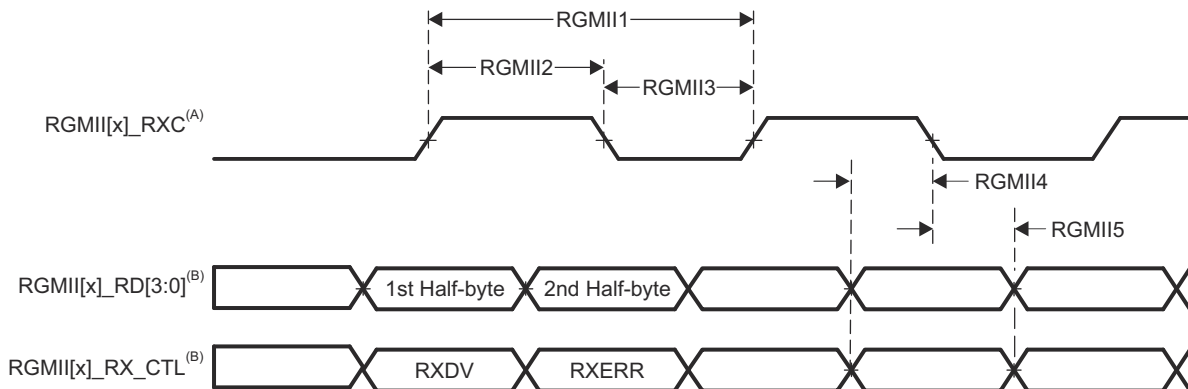

- A. RGMII_RXC must be externally delayed relative to the data and control pins.
- B. Data and control information is received using both edges of the clocks. RGMII_RXD[3:0] carries data bits 3-0 on the rising edge of RGMII_RXC and data bits 7-4 on the falling edge of RGMII_RXC. Similarly, RGMII_RXCTL carries RXDV on rising edge of RGMII_RXC and RXERR on falling edge of RGMII_RXC.

Figure 6-39. CPSW2G Receive Interface Timing, RGMII Operation

[Section 6.10.5.2.3.3](#), [Section 6.10.5.2.3.4](#) present switching characteristics for transmit - RGMII for 10 Mbps, 100 Mbps, and 1000 Mbps.

6.10.5.2.3.3 CPSW2G RGMII[x]_TXC Switching Characteristics – RGMII Mode

NO.	PARAMETER		MODE	MIN	MAX	UNIT
RGMII6	$t_{c(tc)}$	Cycle time, RGMII[x]_TXC	10Mbps	360	440	ns
			100Mbps	36	44	ns
			1000Mbps	7.2	8.8	ns
RGMII7	$t_{w(tcH)}$	Pulse duration, RGMII[x]_TXC high	10Mbps	160	240	ns
			100Mbps	16	24	ns
			1000Mbps	3.6	4.4	ns
RGMII8	$t_{w(tcL)}$	Pulse duration, RGMII[x]_TXC low	10Mbps	160	240	ns
			100Mbps	16	24	ns
			1000Mbps	3.6	4.4	ns

6.10.5.2.3.4 RGMII[x]_TD[3:0], and RGMII[x]_TX_CTL Switching Characteristics – RGMII Mode

see Figure 6-40

NO.	PARAMETER		MODE	MIN	MAX	UNIT
RGMII9	$t_{osu(tdV-txcV)}$	Output setup time, RGMII[x]_TD[3:0] valid to RGMII[x]_TXC transition	10Mbps	1.2		ns
			100Mbps	1.2		ns
			1000Mbps	1.2		ns
	$t_{osu(tx_ctlV-txcV)}$	Output setup time, RGMII[x]_TX_CTL valid to RGMII[x]_TXC transition	10Mbps	1.2		ns
			100Mbps	1.2		ns
			1000Mbps	1.2		ns
RGMII10	$t_{oh(tdV-txcV)}$	Output hold time, RGMII[x]_TD[3:0] valid after RGMII[x]_TXC transition	10Mbps	1.2		ns
			100Mbps	1.2		ns
			1000Mbps	1.2		ns
	$t_{oh(tx_ctlV-txcV)}$	Output hold time, RGMII[x]_TX_CTL valid after RGMII[x]_TXC transition	10Mbps	1.2		ns
			100Mbps	1.2		ns
			1000Mbps	1.2		ns

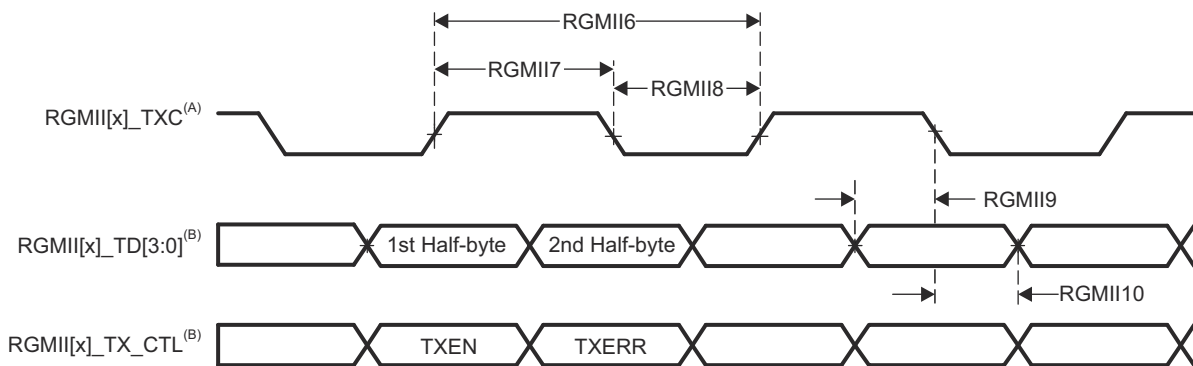

- A. TXC is delayed internally before being driven to the RGMII[x]_TXC pin. This internal delay is always enabled.
- B. Data and control information is received using both edges of the clocks. RGMII_TD[3:0] carries data bits 3-0 on the rising edge of RGMII_TXC and data bits 7-4 on the falling edge of RGMII_TXC. Similarly, RGMII_TX_CTL carries TXDV on rising edge of RGMII_TXC and RTXERR on falling edge of RGMII_TXC.

Figure 6-40. CPSW2G Transmit Interface Timing RGMII Mode

6.10.5.3 CSI-2

Note

For more information, see the Camera Streaming Interface Receiver (CSI_RX_IF) chapter in the device TRM.

The CSI_RX_IF deals with the processing of the pixel data coming from an external image sensor and data from memory. It is a key component for the following multimedia applications: camera viewfinder, video record, and still image capture.

The CSI_RX_IF has a primary serial interface (CSI-2 port) compliant with the MIPI D-PHY RX specification v1.2 and the MIPI CSI-2 specification v1.3, with 4 differential data lanes plus 1 differential clock lane in synchronous mode, double data rate. Refer to the specification for timing details.

- 2.5 Gbps (1.25 GHz) for each lane.

6.10.5.4 DDRSS

For more details about features and additional description information on the device LPDDR4 Memory Interfaces, see the corresponding sections within [Signal Descriptions](#) and *Detailed Description*.

The device has dedicated interface to LPDDR4. It supports JEDEC JESD209-4B standard compliant LPDDR4 SDRAM devices with the following features:

- 32-bit data path to external SDRAM memory
- Memory device capacity: Up to 8GB address space available over two chip selects (4GB per rank)
- No support for byte mode LPDDR4 memories, or memories with more than 17 row address bits

[Table 6-31](#) and [Figure 6-41](#) present switching characteristics for DDRSS.

Table 6-31. Switching Characteristics for DDRSS

NO.	PARAMETER	DDR TYPE	MIN	MAX	UNIT
1	$t_{c(DDR_CKP/DDR_CKN)}$ Cycle time, DDR0_CKP and DDR0_CKN	LPDDR4	0.4681	3.003	ns

1. Maximum DDR Frequency will be limited based on the specific memory type (vendor) used in a system and by PCB implementation. TI strongly recommends all designs to follow the TI LPDDR4 EVM PCB layout exactly in every detail (routing, spacing, vias/backdrill, PCB material, etc.) in order to achieve the full specified clock frequency. Refer to the Jacinto 7 DDR Board Design and Layout Guidelines for details.

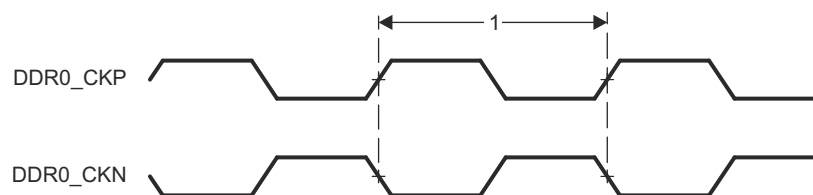

Figure 6-41. DDRSS Memory Interface Clock Timing

For more information, see *DDR Subsystem (DDRSS)* section in *Memory Controllers* chapter in the device TRM.

6.10.5.5 DSS

For more details about features and additional description information on the device Display Subsystem – Video Output Ports, see the corresponding sections within [Signal Descriptions](#) and *Detailed Description*.

[Table 6-32](#) represents DPI timing conditions.

Table 6-32. DPI Timing Conditions

PARAMETER	MIN	MAX	UNIT
INPUT CONDITIONS			
SR_i Input slew rate	1.44	26.4	V/ns

Table 6-32. DPI Timing Conditions (continued)

PARAMETER		MIN	MAX	UNIT
OUTPUT CONDITIONS				
C_L	Output load capacitance	1.5	5	pF
PCB CONNECTIVITY REQUIREMENTS				
t_d (Trace Mismatch Delay)	Propagation delay mismatch across all traces		100	ps

Table 6-33, Table 6-34, Figure 6-42 and Figure 6-43 assume testing over the recommended operating conditions and electrical characteristic conditions.

Table 6-33. DPI Video Output Switching Characteristics

NO.(2)	PARAMETER		MIN	MAX	UNIT
D1	$t_{c(pclk)}$	Cycle time, VOUT(x)_PCLK	6.06		ns
D2	$t_{w(pclkL)}$	Pulse duration, VOUT(x)_PCLK low	$0.475 \times P^{(1)}$		ns
D3	$t_{w(pclkH)}$	Pulse duration, VOUT(x)_PCLK high	$0.475 \times P^{(1)}$		ns
D4	$t_{d(pclkV-dataV)}$	Delay time, VOUT(x)_PCLK transition to VOUT(x)_DATA[23:0] transition	-0.68	1.78	ns
D5	$t_{d(pclkV-ctrlL)}$	Delay time, VOUT(x)_PCLK transition to control signals VOUT(x)_VSYNC, VOUT(x)_HSYNC, VOUT(x)_DE falling edge	-0.68	1.78	ns

- (1) P = output VOUT(x)_PCLK period in ns.
 (2) x in VOUT(x) = 1 or 2

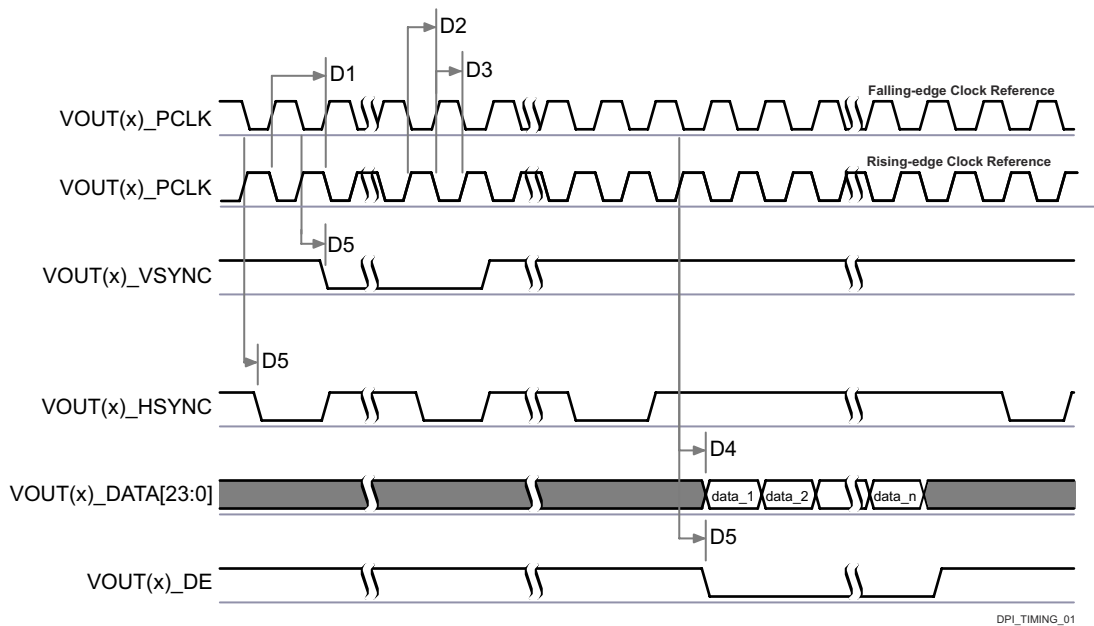

- A. The configuration of assertion of the data can be programmed on the falling or rising edge of the pixel clock.
- B. The polarity and the pulse width of VOUT(x)_HSYNC and VOUT(x)_VSYNC are programmable, refer to *Display Subsystem (DSS)* section in *Peripherals* chapter in the device TRM.
- C. The VOUT(x)_PCLK frequency can be configured, refer to *Display Subsystem* section in *Peripherals* chapter in the device TRM.
- D. x in VOUT(x) = 1 or 2.

Figure 6-42. DPI Video Output

Table 6-34. DPI External Pixel Clock Timing Requirements

NO. ⁽²⁾			MIN	MAX	UNIT
D6	$t_{c(\text{extpclkIn})}$	Cycle time, VOUT(x)_EXTPCLKIN	6.06		ns
D7	$t_{w(\text{extpclkInL})}$	Pulse duration, VOUT(x)_EXTPCLKIN low	$0.45 \times P^{(1)}$		ns
D8	$t_{w(\text{extpclkInH})}$	Pulse duration, VOUT(x)_EXTPCLKIN high	$0.45 \times P^{(1)}$		ns

(1) P = output VOUT(x)_PCLK period in ns.

(2) x in VOUT(x) = 1 or 2

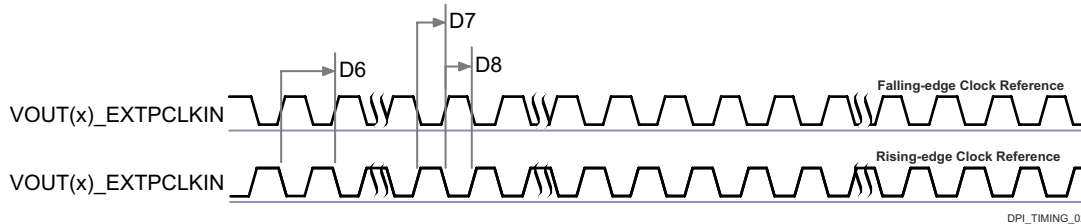
**Figure 6-43. DPI External Pixel Clock Input**

For more information, see *Display Subsystem (DSS) and Peripherals* section in *Peripherals* chapter in the device TRM.

6.10.5.6 eCAP

The supported features by the device ECAP are:

- 32-bit time base counter
- 4-event time-stamp registers (each 32 bits)
- Independent edge polarity selection for up to four sequenced time-stamp capture events
- Interrupt capabilities on any of the four capture events
- Input capture signal pre-scaling (from 1 to 16)
- Support of different capture modes (single shot capture, continuous mode capture, absolute timestamp capture or difference mode time-stamp capture)

Table 6-35 represents ECAP timing conditions.

Table 6-35. ECAP Timing Conditions

PARAMETER		MIN	MAX	UNIT
INPUT CONDITIONS				
SR _I	Input slew rate	1	4	V/ns
OUTPUT CONDITIONS				
C _L	Output load capacitance	2	7	pF

Section 6.10.5.6.1 and Section 6.10.5.6.2 present timing and switching characteristics for eCAP (see Figure 6-44 and Figure 6-45).

6.10.5.6.1 Timing Requirements for eCAP

NO.	PARAMETER	DESCRIPTION	MIN	MAX	UNIT
CAP1	$t_{w(\text{cap})}$	Pulse duration, CAP (asynchronous)	$2 + 2P^{(1)}$		ns

(1) P = sysclk



Figure 6-44. eCAP Input Timings

6.10.5.6.2 Switching Characteristics for eCAP

NO.	PARAMETER	DESCRIPTION	MIN	MAX	UNIT
CAP2	$t_{w(\text{apwm})}$	Pulse duration, APWM	$-2 + 2P^{(1)}$		ns

(1) P = sysclk

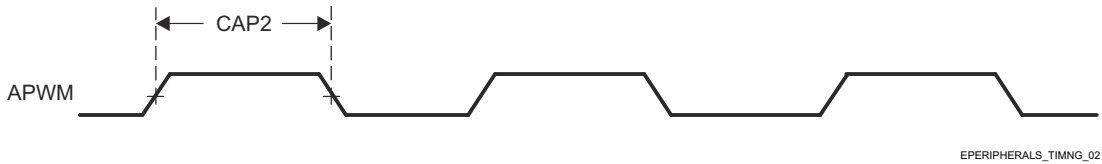

Figure 6-45. eCAP Output Timings

For more information, see *Enhanced Capture (ECAP) Module* section in *Peripherals* chapter in the device TRM.

6.10.5.7 EPWM

The supported features by the device EPWM are:

- Dedicated 16-bit time-base counter with period and frequency control
- Two independent PWM outputs which can be used in different configurations (with single-edge operation, with dual-edge symmetric operation or one independent PWM output with dual-edge asymmetric operation)
- Asynchronous override control of PWM signals during fault conditions
- Programmable phase-control support for lag or lead operation relative to other EPWM modules
- Dead-band generation with independent rising and falling edge delay control
- Programmable trip zone allocation of both latched and un-latched fault conditions
- Events enabling to trigger both CPU interrupts and start of ADC conversions

Table 6-36 represents EPWM timing conditions.

Table 6-36. EPWM Timing Conditions

PARAMETER	DESCRIPTION	MIN	MAX	UNIT
INPUT CONDITIONS				
SR_i	Input slew rate	1	4	V/ns
OUTPUT CONDITIONS				
C_L	Output load capacitance	2	7	pF

Section 6.10.5.7.2, Section 6.10.5.7.1 and present timing and switching characteristics for eHRPWM (see Figure 6-47, Figure 6-48, Figure 6-49, and Figure 6-46).

6.10.5.7.1 Timing Requirements for eHRPWM

NO.	PARAMETER	DESCRIPTION	MIN	MAX	UNIT
PWM6	$t_{w(\text{synci})}$	Pulse duration, EHRPWM_SYNCI	2 + 2P ⁽¹⁾		ns
PWM7	$t_{w(\text{tz})}$	Pulse duration, EHRPWM_TZn_IN low	2 + 3P ⁽¹⁾		ns

(1) P = sysclk

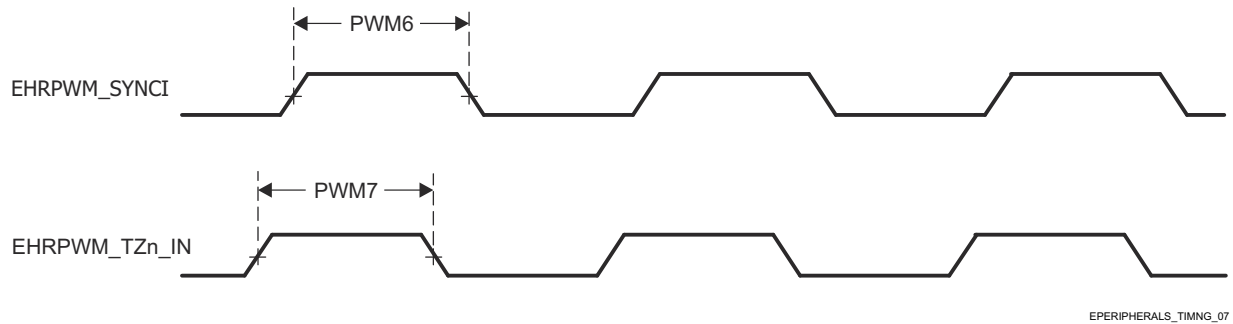

Figure 6-46. ePWM_SYNCI and ePWM_TZn_IN Output Timings

For more information, see *Camera Subsystem* section in *Peripherals* chapter in the device TRM.

6.10.5.7.2 Switching Characteristics for eHRPWM

NO.	PARAMETER	DESCRIPTION	MIN	MAX	UNIT
PWM1	$t_{w(\text{pwm})}$	Pulse duration, EHRPWM_A/B, high or low	P-3 ⁽¹⁾		ns
PWM2	$t_{w(\text{syncout})}$	Pulse duration, EHRPWM_SYNCO	P-3 ⁽¹⁾		ns
PWM3	$t_{d(\text{tzL-pwmV})}$	Delay time, EHRPWM_TZn_IN falling edge to EHRPWM_A/B valid		11	ns
PWM4	$t_{d(\text{tzL-pwmZ})}$	Delay time, EHRPWM_TZn_IN falling edge to EHRPWM_A/B Hi-Z		11	ns

NO.	PARAMETER	DESCRIPTION	MIN	MAX	UNIT
PWM5	$t_{w(soc)}$	Pulse duration, EHRPWM_SOC A/B	P-3 ⁽¹⁾		ns

(1) P = sysclk

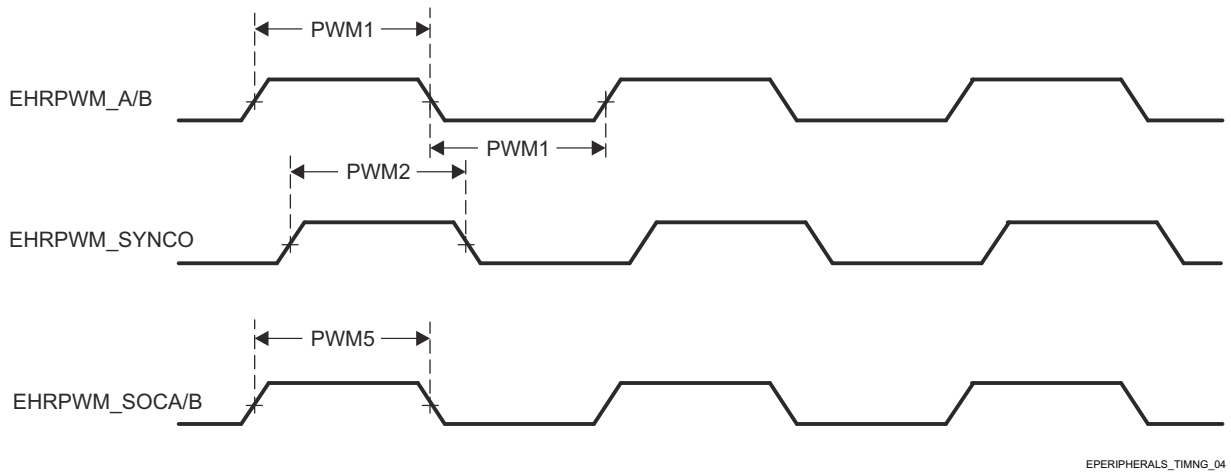

Figure 6-47. EPWM_A/B_out, ePWM_SYNCO, and ePWM_SOC A/B Input Timings

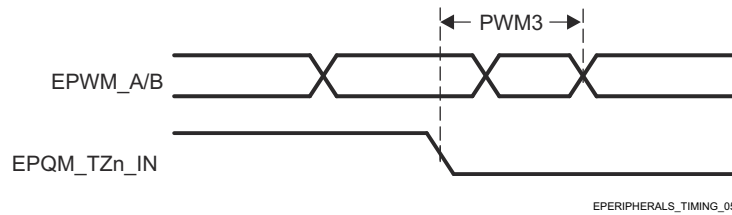

Figure 6-48. EPWM_A/B and ePWM_TZn_IN Forced High/Low Input Timings

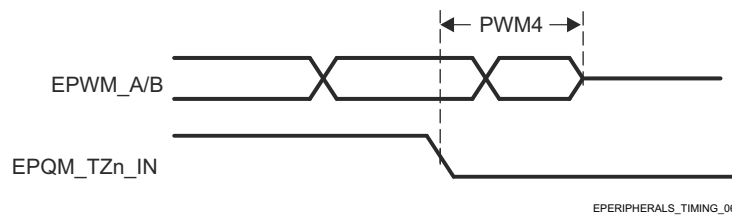

Figure 6-49. EPWM_A/B and ePWM_TZn_IN Hi-Z Input Timings

6.10.5.8 eQEP

The supported features by the device eQEP are:

- Input Synchronization
- Three Stage/Six Stage Digital Noise Filter
- Quadrature Decoder Unit
- Position Counter and Control unit for position measurement
- Quadrature Edge Capture unit for low speed measurement
- Unit Time base for speed/frequency measurement
- Watchdog Timer for detecting stalls

Table 6-37 represents EQEP timing conditions.

Table 6-37. EQEP Timing Conditions

PARAMETER		MIN	MAX	UNIT
INPUT CONDITIONS				
SR _I	Input slew rate	1	4	V/ns
OUTPUT CONDITIONS				
C _L	Output load capacitance	2	7	pF

Section 6.10.5.8.1 and Section 6.10.5.8.2 present timing requirements and switching characteristics for eQEP (see Figure 6-50).

6.10.5.8.1 Timing Requirements for eQEP

NO.	PARAMETER	MIN	MAX	UNIT
QEP1	$t_{w(qep)}$ Pulse duration, QEP_A/B	$2 + 2P^{(1)}$		ns
QEP2	$t_{w(qepiH)}$ Pulse duration, QEP_I high	$2 + 2P^{(1)}$		ns
QEP3	$t_{w(qepiL)}$ Pulse duration, QEP_I low	$2 + 2P^{(1)}$		ns
QEP4	$t_{w(qepsH)}$ Pulse duration, QEP_S high	$2 + 2P^{(1)}$		ns
QEP5	$t_{w(qepsL)}$ Pulse duration, QEP_S low	$2 + 2P^{(1)}$		ns

(1) P = sysclk

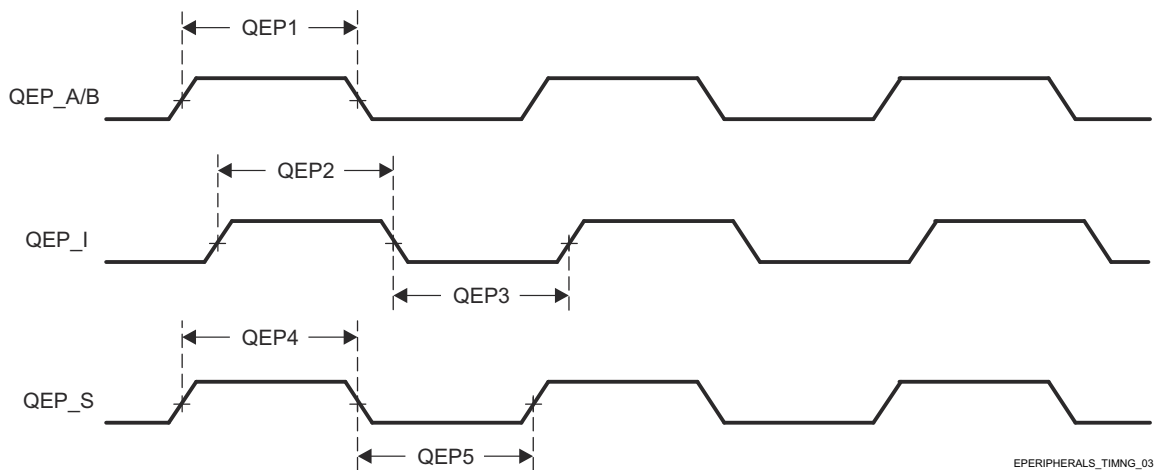
**Figure 6-50. eQEP Input Timings**

6.10.5.8.2 Switching Characteristics for eQEP

NO.	PARAMETER	MIN	MAX	UNIT
QEP6	$t_{d(QEP-CNTR)}$ Delay time, external clock to counter increment		24	ns

For more information, see *Enhanced Quadrature Encoder Pulse (EQEP) Module* section in *Peripherals* chapter in the device TRM.

6.10.5.9 GPIO

The device has ten instances of GPIO modules. The GPIO modules are integrated in three groups.

- Group one: WKUP_GPIO0 and WKUP_GPIO1
- Group two: GPIO0, GPIO2, GPIO4, and GPIO6
- Group three: GPIO1, GPIO3, GPIO5, and GPIO7

Within each group, exactly one module is selected to control the corresponding I/O pins and pin interrupts.

The GPIO pins are grouped into banks (16 pins per bank), which means that each GPIO module provides up to 144 dedicated general-purpose pins with input and output capabilities; thus, the general-purpose interface supports up to 432 (3 instances × (9 banks × 16 pins)) pins. Since WKUP_GPIOu_[84:143] (u = 0, 1), GPIO_n_[128:143] (n = 0, 2, 4, 6), and GPIO_m_[36:143] (m = 1, 3, 5, 7) are reserved in this device, general purpose interface supports up to 248 I/O pins.

For more details about features and additional description information on the device General-Purpose Interface, see the corresponding sections within [Signal Descriptions](#) and [Detailed Description](#).

Note

The general-purpose input/output *i* (*i* = 0 to 1) is also referred to as GPIO_{*i*}.

[Table 6-38](#), [Section 6.10.5.9.1](#), and [Section 6.10.5.9.2](#) present timing conditions, requirements, and switching characteristics for GPIO.

Table 6-38. GPIO Timing Conditions

PARAMETER		BUFFER TYPE	MIN	MAX	UNIT
INPUT CONDITIONS					
SR _{<i>i</i>}	Input slew rate	LVCMOS	0.2	6.6	V/ns
		I2C OD FS	0.2	0.8	V/ns
OUTPUT CONDITIONS					
C _L	Output load capacitance	LVCMOS	3	10	pF
		I2C OD FS	3	100	pF

6.10.5.9.1 GPIO Timing Requirements

NO.	PARAMETER		BUFFER TYPE	MIN	MAX	UNIT
GPIO1	t _{w(gpio_in)}	Pulse width, GPIO _n _x	1.8 V	2P + 2.6 ⁽¹⁾		ns
			3.3 V	2P + 3.4 ⁽¹⁾		ns

(1) P = functional clock period in ns.

6.10.5.9.2 GPIO Switching Characteristics

NO.	PARAMETER		BUFFER TYPE	MIN	MAX	UNIT
GPIO3	t _{w(GPIO_OUT)}	Minimum Output Pulse Width	LVCMOS	-3.6 + 0.975P ⁽¹⁾		ns
GPIO4	t _{w(GPIO_OUT)}	Minimum Output Pulse Width Low	I2C Open Drain	160		ns
GPIO5	t _{w(GPIO_OUT)}	Minimum Output Pulse Width High	I2C Open Drain	60		ns

(1) P = functional clock period in ns.

For more information, see *General-Purpose Interface (GPIO)* section in *Peripherals* chapter in the device TRM.

6.10.5.10 GPMC

For more details about features and additional description information on the device General-Purpose Memory Controller, see the corresponding sections within [Signal Descriptions](#) and [Detailed Description](#).

[Table 6-39](#) represents GPMC timing conditions.

Note

The IO timings provided in this section are applicable for all combinations of signals for GPMC0. However, the timings are only valid for GPMC0 if signals within a single IOSET are used. The IOSETs are defined in the [GPMC0_IOSET](#), [GPMC0_IOSET](#) table.

Table 6-39. GPMC Timing Conditions

PARAMETER	DESCRIPTION	MIN	MAX	UNIT	
Input Conditions					
SR _i	Input slew rate	1.65	4	V/ns	
Output Conditions					
C _L	Output load capacitance	5	20	pF	
PCB Connectivity Requirements					
t _d (Trace Delay)	Propagation delay of each trace	133 MHz Synchronous Mode	140	360	ps
		All other modes	140	720	
t _d (Trace Mismatch Delay)	Propagation mismatch across all traces		200	ps	

6.10.5.10.1 GPMC and NOR Flash — Synchronous Mode

Section 6.10.5.10.1.1 and Section 6.10.5.10.1.2 assume testing over the recommended operating conditions and electrical characteristic conditions below (see Figure 6-51 through Figure 6-55).

6.10.5.10.1.1 GPMC and NOR Flash Timing Requirements — Synchronous Mode

NO.	PARAMETER	DESCRIPTION ⁽²⁾	MODE ⁽³⁾	MIN	MAX	MIN	MAX	UNIT
				100 MHz ⁽⁴⁾		133 MHz ⁽⁴⁾		
F12	t _{su} (dV-clkH)	Setup time, input data GPMC_AD[15:0] valid before output clock GPMC_CLK high	div_by_1_mode; GPMC_FCLK_MUX; TIMEPARAGRANULARITY_X1	1.81		1.11		ns
			not_div_by_1_mode; GPMC_FCLK_MUX; TIMEPARAGRANULARITY_X1	1.06				ns
F13	t _h (clkH-dV)	Hold time, input data GPMC_AD[15:0] valid after output clock GPMC_CLK high	div_by_1_mode; GPMC_FCLK_MUX; TIMEPARAGRANULARITY_X1	1.78		2.28		ns
			not_div_by_1_mode; GPMC_FCLK_MUX; TIMEPARAGRANULARITY_X1	1.78				ns
F21	t _{su} (waitV-clkH)	Setup time, input wait GPMC_WAIT[j] valid before output clock GPMC_CLK high ⁽¹⁾	div_by_1_mode; GPMC_FCLK_MUX; TIMEPARAGRANULARITY_X1	1.81		1.11		ns
			not_div_by_1_mode; GPMC_FCLK_MUX; TIMEPARAGRANULARITY_X1	1.06				ns
F22	t _h (clkH-waitV)	Hold time, input wait GPMC_WAIT[j] valid after output clock GPMC_CLK high ⁽¹⁾	div_by_1_mode; GPMC_FCLK_MUX; TIMEPARAGRANULARITY_X1	1.78		2.28		ns
			not_div_by_1_mode; GPMC_FCLK_MUX; TIMEPARAGRANULARITY_X1	1.78				ns

(1) In GPMC_WAIT[j], j is equal to 0, 1, 2, or 3.

(2) Wait monitoring support is limited to a WaitMonitoringTime value > 0. For a full description of wait monitoring feature, see *General-Purpose Memory Controller (GPMC)* section in the device TRM.

(3) For div_by_1_mode:

- GPMC_CONFIG1_i Register: GPMCFCLKDIVIDER = 0h:
 - GPMC_CLK frequency = GPMC_FCLK frequency
- GPMC_CONFIG1_i Register: GPMCFCLKDIVIDER = 1h to 3h:
 - GPMC_CLK frequency = GPMC_FCLK frequency / (2 to 4)
- CTRLMMR_GPMC_CLKSEL[1-0] CLK_SEL = 01 = PER1_PLL_CLKOUT / 3 = 300 / 3 = 100 MHz
- For TIMEPARAGRANULARITY_X1:

- GPMC_CONFIG1_i Register: TIMEPARAGRANULARITY = 0h = x1 latencies (affecting RD/WRCYCLETIME, RD/WRACCESTIME, PAGEBURSTACCESTIME, CSONTIME, CSRD/WROFFTIME, ADVONTIME, ADVRD/WROFFTIME, OEONTIME, OEOFFTIME, WEONTIME, WEOFFTIME, CYCLE2CYCLEDELAY, BUSTURNAROUND, TIMEOUTSTARTVALUE, WRDATAONADMUXBUS)

(4) For 100 MHz:

- CTRLMMR_GPMC_CLKSEL[1-0] CLK_SEL = 01 = MAIN_PLL2_HSDIV1_CLKOUT / 3

For 133 MHz:

- CTRLMMR_GPMC_CLKSEL[1-0] CLK_SEL = 00 = MAIN_PLL0_HSDIV3_CLKOUT

6.10.5.10.1.2 GPMC and NOR Flash Switching Characteristics – Synchronous Mode

NO. ⁽²⁾	PARAMETER	DESCRIPTION	MODE ⁽¹⁹⁾	MIN	MAX	MIN	MAX	UNIT
				100 MHz ⁽²⁰⁾		133 MHz ⁽²⁰⁾		
F0	tc(clk)	Period, output clock GPMC_CLK ⁽¹⁸⁾	div_by_1_mode; ; GPMC_FCLK_MUX; TIMEPARAGRANULARITY_X1	10		7.52		ns
F1	t _w (clkH)	Typical pulse duration, output clock GPMC_CLK high	div_by_1_mode ; GPMC_FCLK_MUX; TIMEPARAGRANULARITY_X1	0.475*P ⁽¹⁵⁾ - 0.3		0.475*P ⁽¹⁵⁾ - 0.3		ns
F1	t _w (clkL)	Typical pulse duration, output clock GPMC_CLK low	div_by_1_mode ; GPMC_FCLK_MUX; TIMEPARAGRANULARITY_X1	0.475*P ⁽¹⁵⁾ - 0.3		0.475*P ⁽¹⁵⁾ - 0.3		ns
F2	t _d (clkH-csnV)	Delay time, output clock GPMC_CLK rising edge to output chip select GPMC_CSn[j] transition ⁽¹⁴⁾	div_by_1_mode ; GPMC_FCLK_MUX; TIMEPARAGRANULARITY_X1 no extra_delay	F ⁽⁶⁾ - 2.2	F+3.75	F ⁽⁶⁾ - 2.2	F ⁽⁶⁾ + 3.75	ns
F3	t _d (clkH-CSn[j]V)	Delay time, output clock GPMC_CLK rising edge to output chip select GPMC_CSn[j] invalid ⁽¹⁴⁾	div_by_1_mode ; GPMC_FCLK_MUX; TIMEPARAGRANULARITY_X1 no extra_delay	E ⁽⁵⁾ - 2.2	E ⁽⁵⁾ + 3.75	E ⁽⁵⁾ - 2.2	E ⁽⁵⁾ + 3.75	ns
F4	t _d (aV-clk)	Delay time, output address GPMC_A[27:1] valid to output clock GPMC_CLK first edge	div_by_1_mode ; GPMC_FCLK_MUX; TIMEPARAGRANULARITY_X1	B ⁽²⁾ -2.3	B ⁽²⁾ +4.5	B ⁽²⁾ -2.3	B ⁽²⁾ +4.5	ns
F5	t _d (clkH-aV)	Delay time, output clock GPMC_CLK rising edge to output address GPMC_A[27:1] invalid	div_by_1_mode; GPMC_FCLK_MUX; TIMEPARAGRANULARITY_X1	-2.3	4.5	-2.3	4.5	ns
F6	t _d (be[x]nV-clk)	Delay time, output lower byte enable and command latch enable GPMC_BE0n_CLE, output upper byte enable GPMC_BE1n valid to output clock GPMC_CLK first edge	div_by_1_mode ; GPMC_FCLK_MUX; TIMEPARAGRANULARITY_X1	B ⁽²⁾ -2.3	B ⁽²⁾ +1.9	B ⁽²⁾ -2.3	B ⁽²⁾ +1.9	ns
F7	t _d (clkH-be[x]nV)	Delay time, output clock GPMC_CLK rising edge to output lower byte enable and command latch enable GPMC_BE0n_CLE, output upper byte enable GPMC_BE1n invalid ⁽¹¹⁾	div_by_1_mode ; GPMC_FCLK_MUX; TIMEPARAGRANULARITY_X1	D ⁽⁴⁾ -2.3	D ⁽⁴⁾ +1.9	D ⁽⁴⁾ -2.3	D ⁽⁴⁾ +1.9	ns
F7	t _d (clkL-be[x]nV)	Delay time, GPMC_CLK falling edge to GPMC_BE0n_CLE, GPMC_BE1n invalid ⁽¹²⁾	div_by_1_mode ; GPMC_FCLK_MUX; TIMEPARAGRANULARITY_X1	D ⁽⁴⁾ -2.3	D ⁽⁴⁾ +1.9	D ⁽⁴⁾ -2.3	D ⁽⁴⁾ +1.9	ns
F7	t _d (clkL-be[x]nV)	Delay time, GPMC_CLK falling edge to GPMC_BE0n_CLE, GPMC_BE1n invalid ⁽¹³⁾	div_by_1_mode ; GPMC_FCLK_MUX; TIMEPARAGRANULARITY_X1	D ⁽⁴⁾ -2.3	D ⁽⁴⁾ +1.9	D ⁽⁴⁾ -2.3	D ⁽⁴⁾ +1.9	ns

NO. ⁽²⁾	PARAMETER	DESCRIPTION	MODE ⁽¹⁹⁾	MIN	MAX	MIN	MAX	UNI T
				100 MHz ⁽²⁰⁾		133 MHz ⁽²⁰⁾		
F8	t _d (clkH-advn)	Delay time, output clock GPMC_CLK rising edge to output address valid and address latch enable GPMC_ADVn_ALE transition	div_by_1_mode ; GPMC_FCLK_MUX; TIMEPARAGRANULARITY_X1 no extra_delay	G ⁽⁷⁾ -2.3	G ⁽⁷⁾ +4.5	G ⁽⁷⁾ -2.3	G ⁽⁷⁾ +4.5	ns
F9	t _d (clkH-advnIV)	Delay time, output clock GPMC_CLK rising edge to output address valid and address latch enable GPMC_ADVn_ALE invalid	div_by_1_mode; GPMC_FCLK_MUX; TIMEPARAGRANULARITY_X1 no extra_delay	D ⁽⁴⁾ -2.3	D ⁽⁴⁾ +4.5	D ⁽⁴⁾ -2.3	D ⁽⁴⁾ +4.5	ns
F10	t _d (clkH-oen)	Delay time, output clock GPMC_CLK rising edge to output enable GPMC_OEn_REn transition	div_by_1_mode ; GPMC_FCLK_MUX; TIMEPARAGRANULARITY_X1 no extra_delay	H ⁽⁸⁾ -2.3	H ⁽⁸⁾ +3.5	H ⁽⁸⁾ -2.3	H ⁽⁸⁾ +3.5	ns
F11	t _d (clkH-oenIV)	Delay time, output clock GPMC_CLK rising edge to output enable GPMC_OEn_REn invalid	div_by_1_mode ; GPMC_FCLK_MUX; TIMEPARAGRANULARITY_X1 no extra_delay	E ⁽⁸⁾ -2.3	E ⁽⁸⁾ +3.5	E ⁽⁸⁾ -2.3	E ⁽⁸⁾ +3.5	ns
F14	t _d (clkH-wen)	Delay time, output clock GPMC_CLK rising edge to output write enable GPMC_WEn transition	div_by_1_mode ; GPMC_FCLK_MUX; TIMEPARAGRANULARITY_X1 no extra_delay	I ⁽⁹⁾ -2.3	I ⁽⁹⁾ +4.5	I ⁽⁹⁾ -2.3	I ⁽⁹⁾ +4.5	ns
F15	t _d (clkH-do)	Delay time, output clock GPMC_CLK rising edge to output data GPMC_AD[15:0] transition ⁽¹¹⁾	div_by_1_mode ; GPMC_FCLK_MUX; TIMEPARAGRANULARITY_X1	J ⁽¹⁰⁾ -2.3	J ⁽¹⁰⁾ +2.7	J ⁽¹⁰⁾ -2.3	J ⁽¹⁰⁾ +2.7	ns
F15	t _d (clkL-do)	Delay time, GPMC_CLK falling edge to GPMC_AD[15:0] data bus transition ⁽¹²⁾	div_by_1_mode ; GPMC_FCLK_MUX; TIMEPARAGRANULARITY_X1	J ⁽¹⁰⁾ -2.3	J ⁽¹⁰⁾ +2.7	J ⁽¹⁰⁾ -2.3	J ⁽¹⁰⁾ +2.7	ns
F15	t _d (clkL-do)	Delay time, GPMC_CLK falling edge to GPMC_AD[15:0] data bus transition ⁽¹³⁾	div_by_1_mode ; GPMC_FCLK_MUX; TIMEPARAGRANULARITY_X1	J ⁽¹⁰⁾ -2.3	J ⁽¹⁰⁾ +2.7	J ⁽¹⁰⁾ -2.3	J ⁽¹⁰⁾ +2.7	ns
F17	t _d (clkH-be[x]n)	Delay time, output clock GPMC_CLK rising edge to output lower byte enable and command latch enable GPMC_BE0n_CLE transition ⁽¹¹⁾	div_by_1_mode ; GPMC_FCLK_MUX; TIMEPARAGRANULARITY_X1	J ⁽¹⁰⁾ -2.3	J ⁽¹⁰⁾ +1.9	J ⁽¹⁰⁾ -2.3	J ⁽¹⁰⁾ +1.9	ns
F17	t _d (clkL-be[x]n)	Delay time, GPMC_CLK falling edge to GPMC_BE0n_CLE, GPMC_BE1n transition ⁽¹²⁾	div_by_1_mode ; GPMC_FCLK_MUX; TIMEPARAGRANULARITY_X1	J ⁽¹⁰⁾ -2.3	J ⁽¹⁰⁾ +1.9	J ⁽¹⁰⁾ -2.3	J ⁽¹⁰⁾ +1.9	ns
F17	t _d (clkL-be[x]n)	Delay time, GPMC_CLK falling edge to GPMC_BE0n_CLE, GPMC_BE1n transition ⁽¹³⁾	div_by_1_mode ; GPMC_FCLK_MUX; TIMEPARAGRANULARITY_X1	J ⁽¹⁰⁾ -2.3	J ⁽¹⁰⁾ +1.9	J ⁽¹⁰⁾ -2.3	J ⁽¹⁰⁾ +1.9	ns
F18	t _w (csnV)	Pulse duration, output chip select GPMC_CS[n] low ⁽¹⁴⁾	Read	A ⁽¹⁾		A ⁽¹⁾		ns
			Write	A ⁽¹⁾		A ⁽¹⁾		ns
F19	t _w (be[x]nV)	Pulse duration, output lower byte enable and command latch enable GPMC_BE0n_CLE, output upper byte enable GPMC_BE1n low	Read	C ⁽³⁾		C ⁽³⁾		ns
			Write	C ⁽³⁾		C ⁽³⁾		ns

NO. ⁽²⁾	PARAMETER	DESCRIPTION	MODE ⁽¹⁹⁾	MIN	MAX	MIN	MAX	UNI T
				100 MHz ⁽²⁰⁾		133 MHz ⁽²⁰⁾		
F20	t _{w(advnV)}	Pulse duration, output address valid and address latch enable GPMC_ADVn_ALE low	Read	K ⁽¹⁶⁾		K ⁽¹⁶⁾		ns
			Write	K ⁽¹⁶⁾		K ⁽¹⁶⁾		ns

- (1) For single read: $A = (\text{CSRdOffTime} - \text{CSOnTime}) \times (\text{TimeParaGranularity} + 1) \times \text{GPMC_FCLK}^{(17)}$
 For burst read: $A = (\text{CSRdOffTime} - \text{CSOnTime} + (n - 1) \times \text{PageBurstAccessTime}) \times (\text{TimeParaGranularity} + 1) \times \text{GPMC_FCLK}^{(17)}$
 For burst write: $A = (\text{CSWrOffTime} - \text{CSOnTime} + (n - 1) \times \text{PageBurstAccessTime}) \times (\text{TimeParaGranularity} + 1) \times \text{GPMC_FCLK}^{(17)}$
 With n being the page burst access number.

(2) $B = \text{ClkActivationTime} \times \text{GPMC_FCLK}^{(17)}$

- (3) For single read: $C = \text{RdCycleTime} \times (\text{TimeParaGranularity} + 1) \times \text{GPMC_FCLK}^{(17)}$
 For burst read: $C = (\text{RdCycleTime} + (n - 1) \times \text{PageBurstAccessTime}) \times (\text{TimeParaGranularity} + 1) \times \text{GPMC_FCLK}^{(17)}$
 For burst write: $C = (\text{WrCycleTime} + (n - 1) \times \text{PageBurstAccessTime}) \times (\text{TimeParaGranularity} + 1) \times \text{GPMC_FCLK}^{(17)}$
 With n being the page burst access number.

- (4) For single read: $D = (\text{RdCycleTime} - \text{AccessTime}) \times (\text{TimeParaGranularity} + 1) \times \text{GPMC_FCLK}^{(17)}$
 For burst read: $D = (\text{RdCycleTime} - \text{AccessTime}) \times (\text{TimeParaGranularity} + 1) \times \text{GPMC_FCLK}^{(17)}$
 For burst write: $D = (\text{WrCycleTime} - \text{AccessTime}) \times (\text{TimeParaGranularity} + 1) \times \text{GPMC_FCLK}^{(17)}$

- (5) For single read: $E = (\text{CSRdOffTime} - \text{AccessTime}) \times (\text{TimeParaGranularity} + 1) \times \text{GPMC_FCLK}^{(17)}$
 For burst read: $E = (\text{CSRdOffTime} - \text{AccessTime}) \times (\text{TimeParaGranularity} + 1) \times \text{GPMC_FCLK}^{(17)}$
 For burst write: $E = (\text{CSWrOffTime} - \text{AccessTime}) \times (\text{TimeParaGranularity} + 1) \times \text{GPMC_FCLK}^{(17)}$

- (6) For csn falling edge (CS activated):

- Case GPMCFCLKDIVIDER = 0:
 - $F = 0.5 \times \text{CSEExtraDelay} \times \text{GPMC_FCLK}^{(17)}$
- Case GPMCFCLKDIVIDER = 1:
 - $F = 0.5 \times \text{CSEExtraDelay} \times \text{GPMC_FCLK}^{(17)}$ if (ClkActivationTime and CSOnTime are odd) or (ClkActivationTime and CSOnTime are even)
 - $F = (1 + 0.5 \times \text{CSEExtraDelay}) \times \text{GPMC_FCLK}^{(17)}$ otherwise
- Case GPMCFCLKDIVIDER = 2:
 - $F = 0.5 \times \text{CSEExtraDelay} \times \text{GPMC_FCLK}^{(17)}$ if ((CSOnTime - ClkActivationTime) is a multiple of 3)
 - $F = (1 + 0.5 \times \text{CSEExtraDelay}) \times \text{GPMC_FCLK}^{(17)}$ if ((CSOnTime - ClkActivationTime - 1) is a multiple of 3)
 - $F = (2 + 0.5 \times \text{CSEExtraDelay}) \times \text{GPMC_FCLK}^{(17)}$ if ((CSOnTime - ClkActivationTime - 2) is a multiple of 3)

- (7) For ADV falling edge (ADV activated):

- Case GPMCFCLKDIVIDER = 0:
 - $G = 0.5 \times \text{ADVExtraDelay} \times \text{GPMC_FCLK}^{(17)}$
- Case GPMCFCLKDIVIDER = 1:
 - $G = 0.5 \times \text{ADVExtraDelay} \times \text{GPMC_FCLK}^{(17)}$ if (ClkActivationTime and ADVOnTime are odd) or (ClkActivationTime and ADVOnTime are even)
 - $G = (1 + 0.5 \times \text{ADVExtraDelay}) \times \text{GPMC_FCLK}^{(17)}$ otherwise
- Case GPMCFCLKDIVIDER = 2:
 - $G = 0.5 \times \text{ADVExtraDelay} \times \text{GPMC_FCLK}^{(17)}$ if ((ADVOnTime - ClkActivationTime) is a multiple of 3)
 - $G = (1 + 0.5 \times \text{ADVExtraDelay}) \times \text{GPMC_FCLK}^{(17)}$ if ((ADVOnTime - ClkActivationTime - 1) is a multiple of 3)
 - $G = (2 + 0.5 \times \text{ADVExtraDelay}) \times \text{GPMC_FCLK}^{(17)}$ if ((ADVOnTime - ClkActivationTime - 2) is a multiple of 3)

For ADV rising edge (ADV deactivated) in Reading mode:

- Case GPMCFCLKDIVIDER = 0:
 - $G = 0.5 \times \text{ADVExtraDelay} \times \text{GPMC_FCLK}^{(17)}$
- Case GPMCFCLKDIVIDER = 1:
 - $G = 0.5 \times \text{ADVExtraDelay} \times \text{GPMC_FCLK}^{(17)}$ if (ClkActivationTime and ADVRdOffTime are odd) or (ClkActivationTime and ADVRdOffTime are even)
 - $G = (1 + 0.5 \times \text{ADVExtraDelay}) \times \text{GPMC_FCLK}^{(17)}$ otherwise
- Case GPMCFCLKDIVIDER = 2:
 - $G = 0.5 \times \text{ADVExtraDelay} \times \text{GPMC_FCLK}^{(17)}$ if ((ADVRdOffTime - ClkActivationTime) is a multiple of 3)
 - $G = (1 + 0.5 \times \text{ADVExtraDelay}) \times \text{GPMC_FCLK}^{(17)}$ if ((ADVRdOffTime - ClkActivationTime - 1) is a multiple of 3)
 - $G = (2 + 0.5 \times \text{ADVExtraDelay}) \times \text{GPMC_FCLK}^{(17)}$ if ((ADVRdOffTime - ClkActivationTime - 2) is a multiple of 3)

For ADV rising edge (ADV deactivated) in Writing mode:

- Case GPMCFCLKDIVIDER = 0:

- $G = 0.5 \times \text{ADVExtraDelay} \times \text{GPMC_FCLK}^{(17)}$
 - Case GPMCFCLKDIVIDER = 1:
 - $G = 0.5 \times \text{ADVExtraDelay} \times \text{GPMC_FCLK}^{(17)}$ if (ClkActivationTime and ADVWrOffTime are odd) or (ClkActivationTime and ADVWrOffTime are even)
 - $G = (1 + 0.5 \times \text{ADVExtraDelay}) \times \text{GPMC_FCLK}^{(17)}$ otherwise
 - Case GPMCFCLKDIVIDER = 2:
 - $G = 0.5 \times \text{ADVExtraDelay} \times \text{GPMC_FCLK}^{(17)}$ if ((ADVWrOffTime - ClkActivationTime) is a multiple of 3)
 - $G = (1 + 0.5 \times \text{ADVExtraDelay}) \times \text{GPMC_FCLK}^{(17)}$ if ((ADVWrOffTime - ClkActivationTime - 1) is a multiple of 3)
 - $G = (2 + 0.5 \times \text{ADVExtraDelay}) \times \text{GPMC_FCLK}^{(17)}$ if ((ADVWrOffTime - ClkActivationTime - 2) is a multiple of 3)
- (8) For OE falling edge (OE activated) and IO DIR rising edge (Data Bus input direction):
- Case GPMCFCLKDIVIDER = 0:
 - $H = 0.5 \times \text{OEEExtraDelay} \times \text{GPMC_FCLK}^{(17)}$
 - Case GPMCFCLKDIVIDER = 1:
 - $H = 0.5 \times \text{OEEExtraDelay} \times \text{GPMC_FCLK}^{(17)}$ if (ClkActivationTime and OEOnTime are odd) or (ClkActivationTime and OEOnTime are even)
 - $H = (1 + 0.5 \times \text{OEEExtraDelay}) \times \text{GPMC_FCLK}^{(17)}$ otherwise
 - Case GPMCFCLKDIVIDER = 2:
 - $H = 0.5 \times \text{OEEExtraDelay} \times \text{GPMC_FCLK}^{(17)}$ if ((OEOnTime - ClkActivationTime) is a multiple of 3)
 - $H = (1 + 0.5 \times \text{OEEExtraDelay}) \times \text{GPMC_FCLK}^{(17)}$ if ((OEOnTime - ClkActivationTime - 1) is a multiple of 3)
 - $H = (2 + 0.5 \times \text{OEEExtraDelay}) \times \text{GPMC_FCLK}^{(17)}$ if ((OEOnTime - ClkActivationTime - 2) is a multiple of 3)
- For OE rising edge (OE deactivated):
- Case GPMCFCLKDIVIDER = 0:
 - $H = 0.5 \times \text{OEEExtraDelay} \times \text{GPMC_FCLK}^{(17)}$
 - Case GPMCFCLKDIVIDER = 1:
 - $H = 0.5 \times \text{OEEExtraDelay} \times \text{GPMC_FCLK}^{(17)}$ if (ClkActivationTime and OEOffTime are odd) or (ClkActivationTime and OEOffTime are even)
 - $H = (1 + 0.5 \times \text{OEEExtraDelay}) \times \text{GPMC_FCLK}^{(17)}$ otherwise
 - Case GPMCFCLKDIVIDER = 2:
 - $H = 0.5 \times \text{OEEExtraDelay} \times \text{GPMC_FCLK}^{(17)}$ if ((OEOffTime - ClkActivationTime) is a multiple of 3)
 - $H = (1 + 0.5 \times \text{OEEExtraDelay}) \times \text{GPMC_FCLK}^{(17)}$ if ((OEOffTime - ClkActivationTime - 1) is a multiple of 3)
 - $H = (2 + 0.5 \times \text{OEEExtraDelay}) \times \text{GPMC_FCLK}^{(17)}$ if ((OEOffTime - ClkActivationTime - 2) is a multiple of 3)
- (9) For WE falling edge (WE activated):
- Case GPMCFCLKDIVIDER = 0:
 - $I = 0.5 \times \text{WEEExtraDelay} \times \text{GPMC_FCLK}^{(17)}$
 - Case GPMCFCLKDIVIDER = 1:
 - $I = 0.5 \times \text{WEEExtraDelay} \times \text{GPMC_FCLK}^{(17)}$ if (ClkActivationTime and WEOnTime are odd) or (ClkActivationTime and WEOnTime are even)
 - $I = (1 + 0.5 \times \text{WEEExtraDelay}) \times \text{GPMC_FCLK}^{(17)}$ otherwise
 - Case GPMCFCLKDIVIDER = 2:
 - $I = 0.5 \times \text{WEEExtraDelay} \times \text{GPMC_FCLK}^{(17)}$ if ((WEOnTime - ClkActivationTime) is a multiple of 3)
 - $I = (1 + 0.5 \times \text{WEEExtraDelay}) \times \text{GPMC_FCLK}^{(17)}$ if ((WEOnTime - ClkActivationTime - 1) is a multiple of 3)
 - $I = (2 + 0.5 \times \text{WEEExtraDelay}) \times \text{GPMC_FCLK}^{(17)}$ if ((WEOnTime - ClkActivationTime - 2) is a multiple of 3)
- For WE rising edge (WE deactivated):
- Case GPMCFCLKDIVIDER = 0:
 - $I = 0.5 \times \text{WEEExtraDelay} \times \text{GPMC_FCLK}^{(17)}$
 - Case GPMCFCLKDIVIDER = 1:
 - $I = 0.5 \times \text{WEEExtraDelay} \times \text{GPMC_FCLK}^{(17)}$ if (ClkActivationTime and WEOffTime are odd) or (ClkActivationTime and WEOffTime are even)
 - $I = (1 + 0.5 \times \text{WEEExtraDelay}) \times \text{GPMC_FCLK}^{(17)}$ otherwise
 - Case GPMCFCLKDIVIDER = 2:
 - $I = 0.5 \times \text{WEEExtraDelay} \times \text{GPMC_FCLK}^{(17)}$ if ((WEOffTime - ClkActivationTime) is a multiple of 3)
 - $I = (1 + 0.5 \times \text{WEEExtraDelay}) \times \text{GPMC_FCLK}^{(17)}$ if ((WEOffTime - ClkActivationTime - 1) is a multiple of 3)

- $I = (2 + 0.5 \times \text{WEEExtraDelay}) \times \text{GPMC_FCLK}^{(17)}$ if $((\text{WEOffTime} - \text{ClkActivationTime} - 2))$ is a multiple of 3
- (10) $J = \text{GPMC_FCLK}^{(17)}$
- (11) First transfer only for CLK DIV 1 mode.
- (12) Half cycle; for all data after initial transfer for CLK DIV 1 mode.
- (13) Half cycle of GPMC_CLKOUT; for all data for modes other than CLK DIV 1 mode. GPMC_CLKOUT divide down from GPMC_FCLK.
- (14) In GPMC_CS*n*[*i*], *i* is equal to 0, 1, 2, or 3. In GPMC_WAIT[j], *j* is equal to 0, 1, 2, or 3.
- (15) P = GPMC_CLK period in ns
- (16) For read: $K = (\text{ADVrdOffTime} - \text{ADVOnTime}) \times (\text{TimeParaGranularity} + 1) \times \text{GPMC_FCLK}^{(17)}$
For write: $K = (\text{ADVwrOffTime} - \text{ADVOnTime}) \times (\text{TimeParaGranularity} + 1) \times \text{GPMC_FCLK}^{(17)}$
- (17) GPMC_FCLK is general-purpose memory controller internal functional clock period in ns.
- (18) Related to the GPMC_CLK output clock maximum and minimum frequencies programmable in the GPMC module by setting the GPMC_CONFIG1_i configuration register bit field GPMCFCLKDIVIDER.
- (19) For div_by_1_mode:
 - GPMC_CONFIG1_i register: GPMCFCLKDIVIDER = 0h:
 - GPMC_CLK frequency = GPMC_FCLK frequency
 - CTRLMMR_GPMC_CLKSEL[1-0] CLK_SEL = 01 = PER1_PLL_CLKOUT / 3 = 300 / 3 = 100 MHz
 - GPMC_CONFIG1_i Register: TIMEPARAGRANULARITY = 0h = x1 latencies (affecting RD/WRCYCLETIME, RD/WRACCESSTIME, PAGEBURSTACCESSTIME, CSONTIME, CSRd/WROFFTIME, ADVONTIME, ADVRD/WROFFTIME, OEONTIME, OEOFFTIME, WEONTIME, WEOFFTIME, CYCLE2CYCLEDELAY, BUSTURNAROUND, TIMEOUTSTARTVALUE, WRDATAONADMUXBUS)
- For no extra_delay:
 - GPMC_CONFIG2_i Register: CSEXTRADELAY = 0h = CS*n* Timing control signal is not delayed
 - GPMC_CONFIG4_i Register: WEEXTRADELAY = 0h = nWE timing control signal is not delayed
 - GPMC_CONFIG4_i Register: OEEXTRADELAY = 0h = nOE timing control signal is not delayed
 - GPMC_CONFIG3_i Register: ADVEXTRADELAY = 0h = nADV timing control signal is not delayed
- (20) For 100 MHz:
 - CTRLMMR_GPMC_CLKSEL[1-0] CLK_SEL = 01 = MAIN_PLL2_HSDIV1_CLKOUT / 3
- For 133 MHz:
 - CTRLMMR_GPMC_CLKSEL[1-0] CLK_SEL = 00 = MAIN_PLL0_HSDIV3_CLKOUT

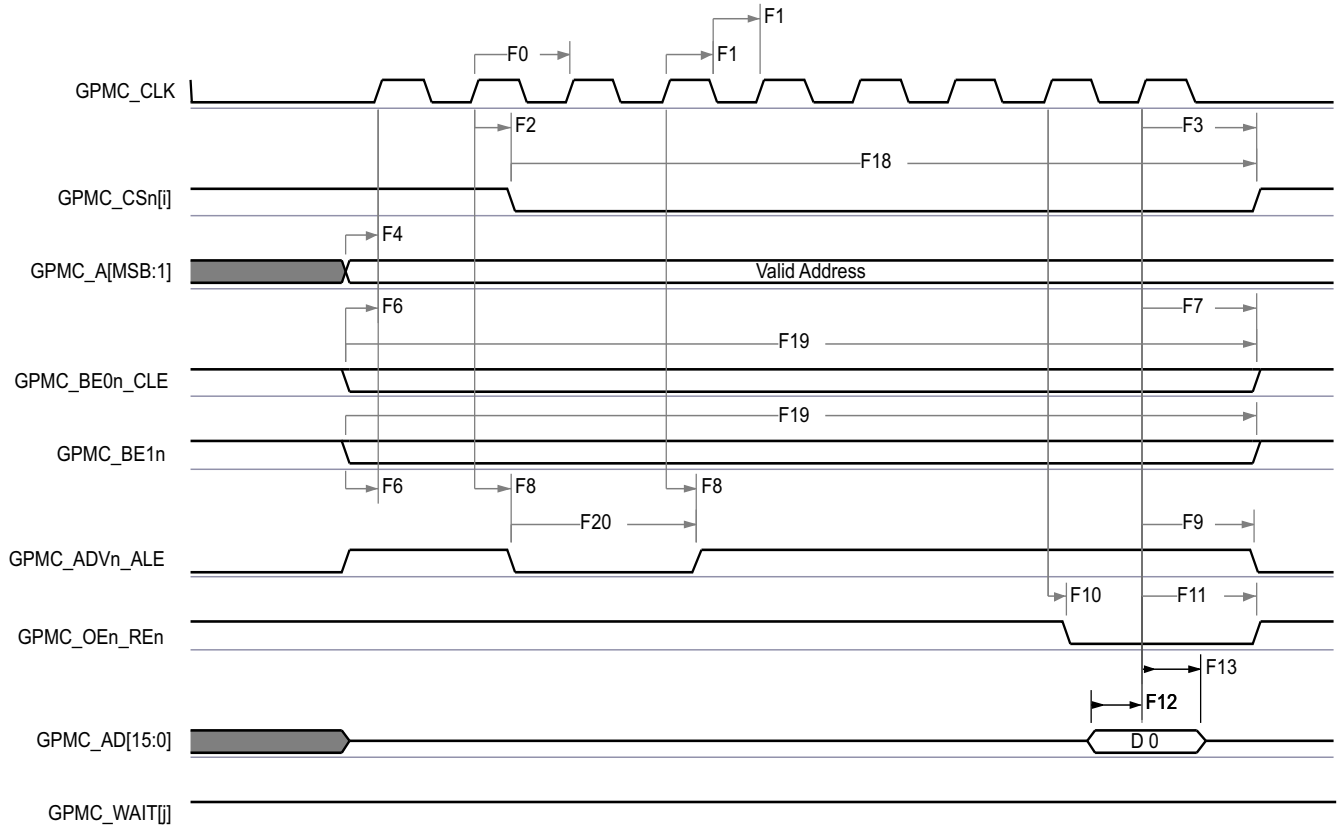

GPMC_01

- A. In GPMC_CSn[i], i is equal to 0, 1, 2 or 3.
- B. In GPMC_WAIT[j], j is equal to 0, 1, 2, or 3.

Figure 6-51. GPMC and NOR Flash — Synchronous Single Read (GPMCFCLKDIVIDER = 0)

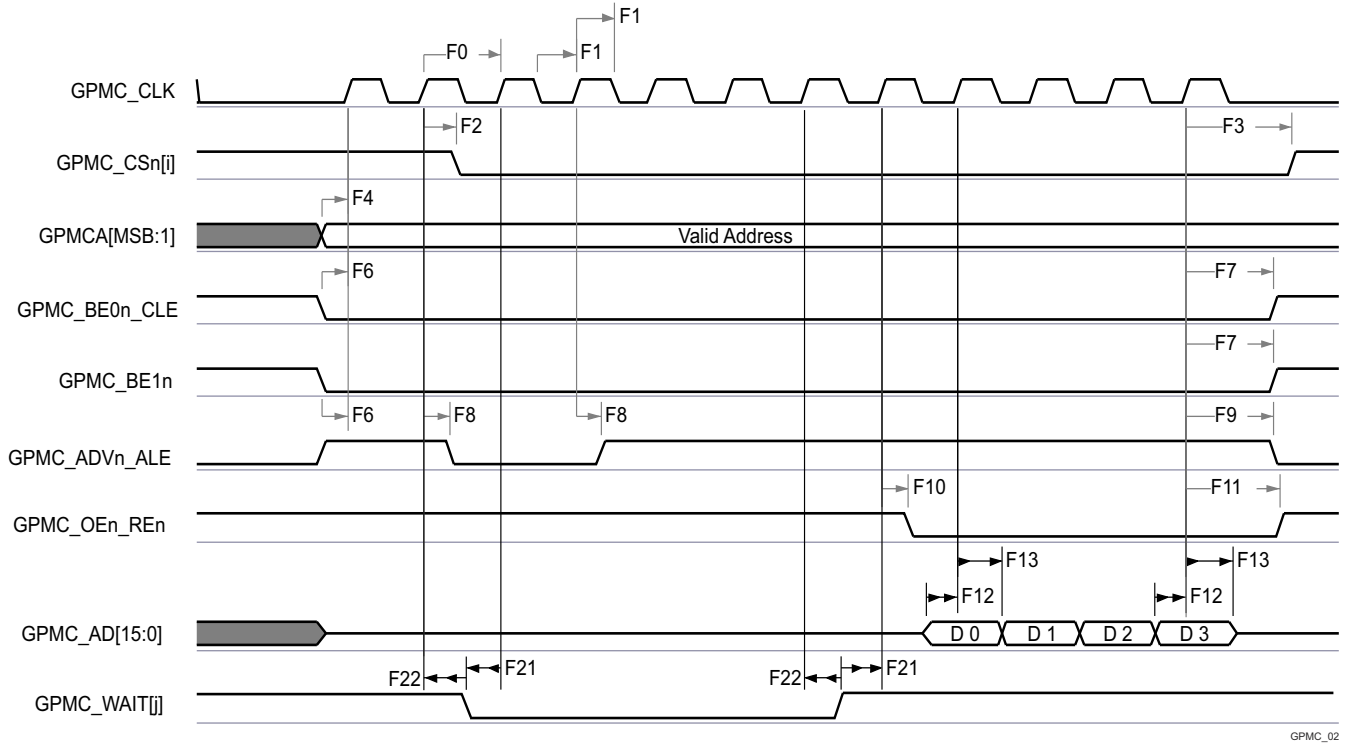

GPMC_02

- A. In GPMC_CS*n*[*j*], *i* is equal to 0, 1, 2 or 3.
- B. In GPMC_WAIT[i], *j* is equal to 0, 1, 2, or 3.

Figure 6-52. GPMC and NOR Flash — Synchronous Burst Read — 4x16-bit (GPMCFCLKDIVIDER = 0)

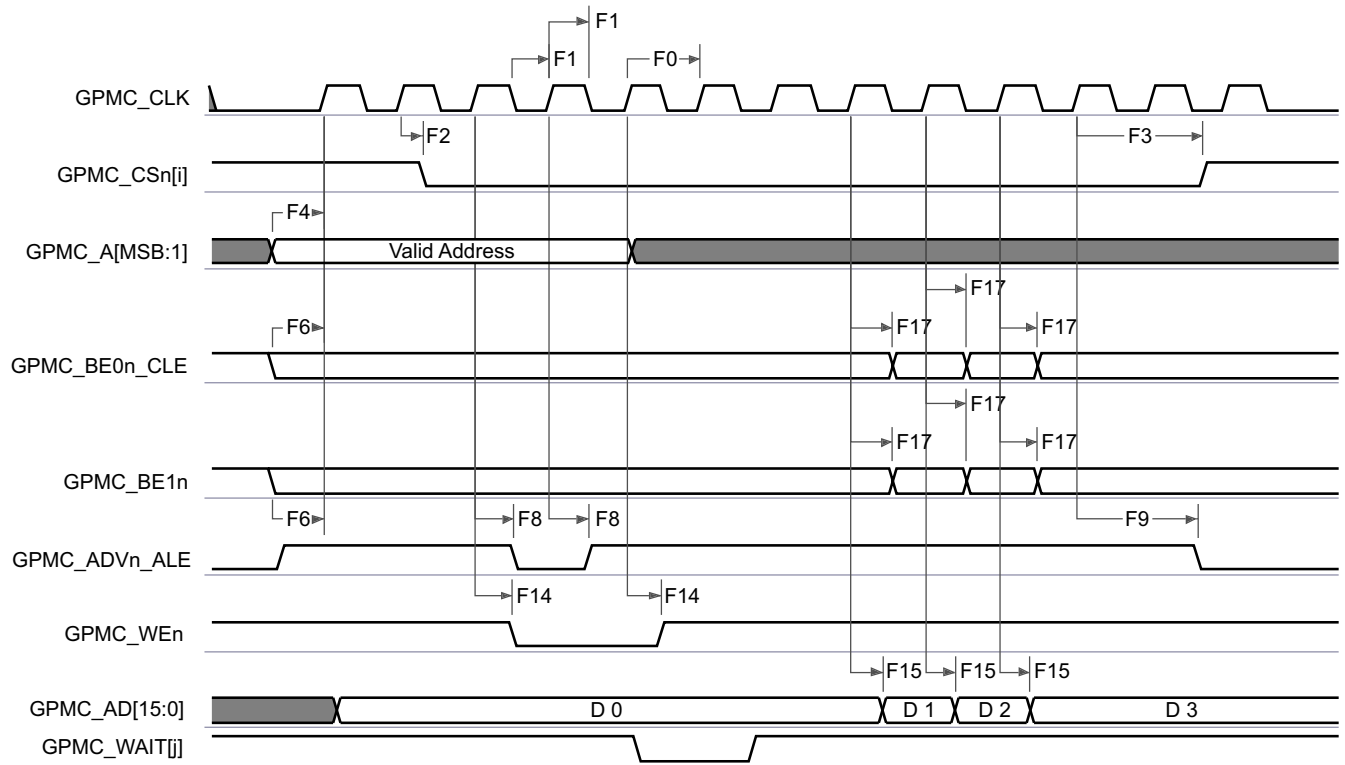

GPMC_03

- A. In GPMC_CS*n*[*j*], *i* is equal to 0, 1, 2 or 3.

B. In GPMC_WAIT[j], j is equal to 0, 1, 2, or 3.

Figure 6-53. GPMC and NOR Flash—Synchronous Burst Write (GPMCFCLKDIVIDER = 0)

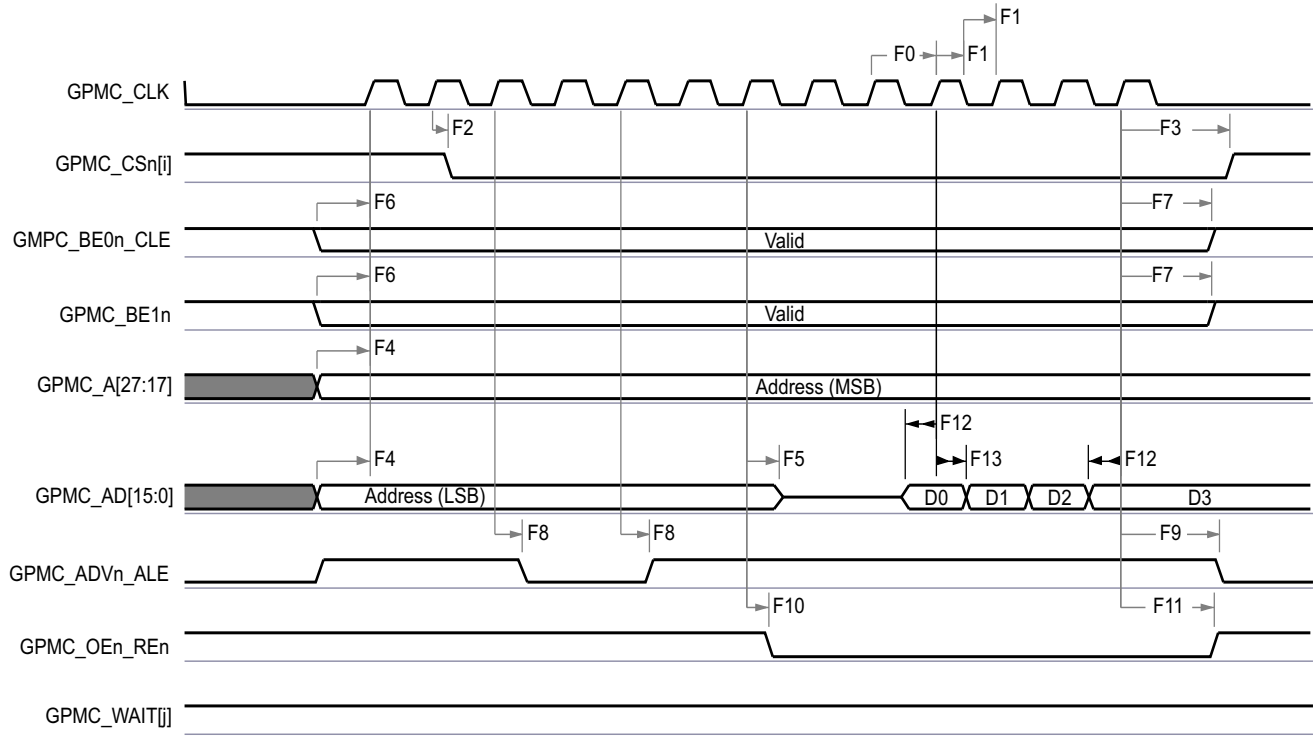

GPMC_04

A. In GPMC_CSn[i], i is equal to 0, 1, 2 or 3.

B. In GPMC_WAIT[j], j is equal to 0, 1, 2, or 3.

Figure 6-54. GPMC and Multiplexed NOR Flash — Synchronous Burst Read

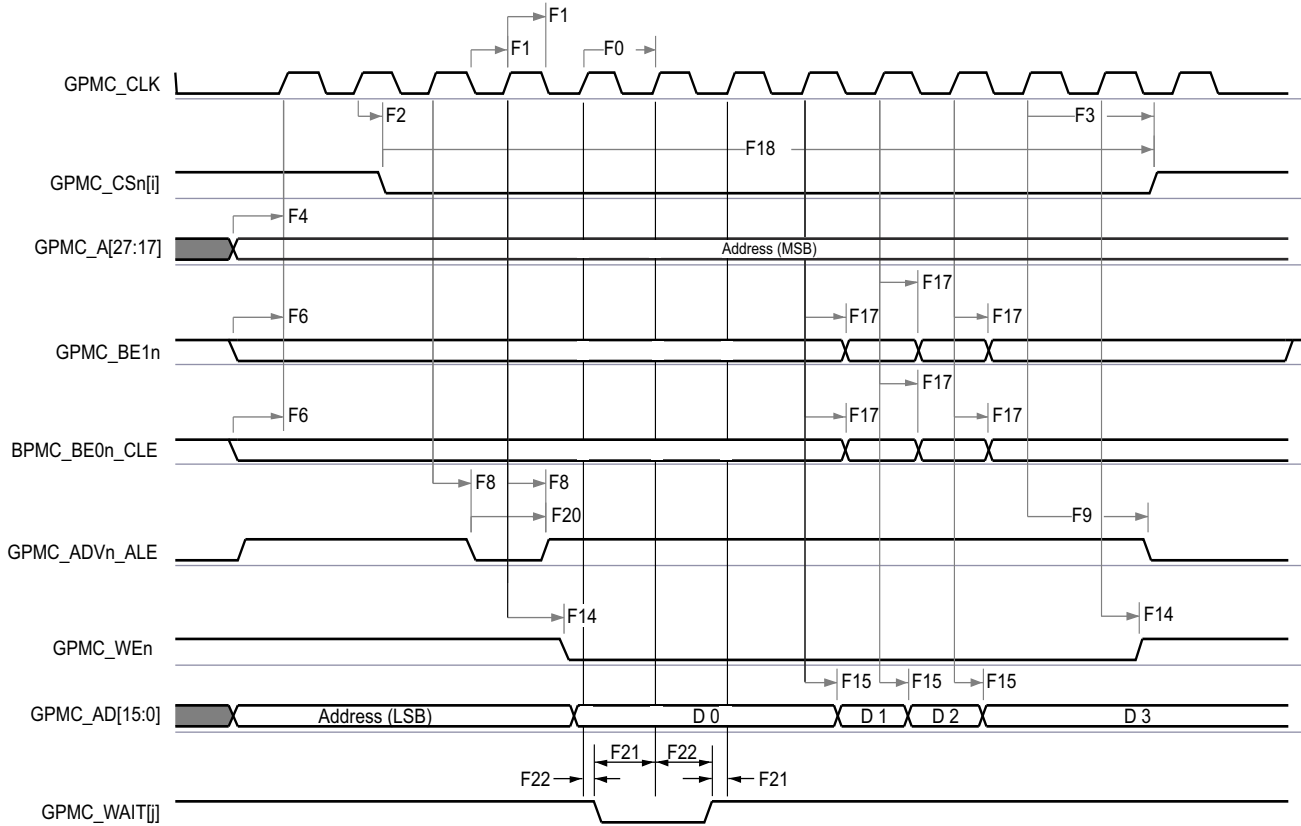

GPMC_05

- A. In GPMC_CS[n], i is equal to 0, 1, 2 or 3.
- B. In GPMC_WAIT[j], j is equal to 0, 1, 2, or 3.

Figure 6-55. GPMC and Multiplexed NOR Flash — Synchronous Burst Write

6.10.5.10.2 GPMC and NOR Flash — Asynchronous Mode

Section 6.10.5.10.2.1 and Section 6.10.5.10.2.2 assume testing over the recommended operating conditions and electrical characteristic conditions below (see Figure 6-56 through Figure 6-61).

6.10.5.10.2.1 GPMC and NOR Flash Timing Requirements – Asynchronous Mode

NO.			MODE ⁽⁷⁾	MIN	MAX	UNIT
FA5 ⁽¹⁾	t _{acc(d)}	Data access time	div_by_1_mode ; GPMC_FCLK_MUX; TIMEPARAGRANULARITY_X 1		H ⁽⁵⁾	ns
FA20 ⁽²⁾	t _{acc1-pgmode(d)}	Page mode successive data access time	div_by_1_mode ; GPMC_FCLK_MUX; TIMEPARAGRANULARITY_X 1		P ⁽⁴⁾	ns
FA21 ⁽³⁾	t _{acc2-pgmode(d)}	Page mode first data access time	div_by_1_mode ; GPMC_FCLK_MUX; TIMEPARAGRANULARITY_X 1		H ⁽⁵⁾	ns

- (1) The FA5 parameter illustrates the amount of time required to internally sample input data. It is expressed in number of GPMC functional clock cycles. From start of read cycle and after FA5 functional clock cycles, input data is internally sampled by active functional clock edge. FA5 value must be stored inside the AccessTime register bit field.
- (2) The FA20 parameter illustrates amount of time required to internally sample successive input page data. It is expressed in number of GPMC functional clock cycles. After each access to input page data, next input page data is internally sampled by active functional clock edge after FA20 functional clock cycles. The FA20 value must be stored in the PageBurstAccessTime register bit field.

- (3) The FA21 parameter illustrates amount of time required to internally sample first input page data. It is expressed in number of GPMC functional clock cycles. From start of read cycle and after FA21 functional clock cycles, first input page data is internally sampled by active functional clock edge. FA21 value must be stored inside the AccessTime register bit field.
- (4) $P = \text{PageBurstAccessTime} \times (\text{TimeParaGranularity} + 1) \times \text{GPMC_FCLK}^{(6)}$
- (5) $H = \text{AccessTime} \times (\text{TimeParaGranularity} + 1) \times \text{GPMC_FCLK}^{(6)}$
- (6) GPMC_FCLK is general-purpose memory controller internal functional clock period in ns.
- (7) For div_by_1_mode:
- GPMC_CONFIG1_i Register: GPMCFCLKDIVIDER = 0h:
 - GPMC_CLK frequency = GPMC_FCLK frequency
 - CTRLMMR_GPMC_CLKSEL[1-0] CLK_SEL = 00 = CPSWHS DIV_CLKOUT3 = 2000/15 = 133.33 MHz
 - GPMC_CONFIG1_i Register: TIMEPARAGRANULARITY = 0h = x1 latencies (affecting RD/WRCYCLETIME, RD/WRACCESSTIME, PAGEBURSTACCESSTIME, CSONTIME, CSRD/WROFFTIME, ADVONTIME, ADVRD/WROFFTIME, OEONTIME, OEOFFTIME, WEONTIME, WEOFFTIME, CYCLE2CYCLEDELAY, BUSTURNAROUND, TIMEOUTSTARTVALUE, WRDATAONADMUXBUS)

6.10.5.10.2.2 GPMC and NOR Flash Switching Characteristics – Asynchronous Mode

NO.	PARAMETER	DESCRIPTION	MODE ⁽¹⁵⁾	MIN	MAX	UNIT
				133 MHz ⁽¹⁶⁾		
FA0	$t_{w(\text{be}[x]nV)}$	Pulse duration, output lower-byte enable and command latch enable GPMC_BE0n_CLE, output upper-byte enable GPMC_BE1n valid time	Read		N ⁽¹²⁾	ns
			Write		N ⁽¹²⁾	
FA1	$t_{w(\text{csn}V)}$	Pulse duration, output chip select GPMC_CS _n [j] ⁽¹³⁾ low	Read		A ⁽¹⁾	ns
			Write		A ⁽¹⁾	
FA3	$t_{d(\text{csn}V\text{-advn}IV)}$	Delay time, output chip select GPMC_CS _n [j] ⁽¹³⁾ valid to output address valid and address latch enable GPMC_ADV _n _ALE invalid	Read	B ⁽²⁾ - 2.55	B ⁽²⁾ + 2.65	ns
			Write	B ⁽²⁾ - 2.55	B ⁽²⁾ + 2.65	
FA4	$t_{d(\text{csn}V\text{-oen}IV)}$	Delay time, output chip select GPMC_CS _n [j] ⁽¹³⁾ valid to output enable GPMC_OEn_REn invalid (Single read)	div_by_1_mode; GPMC_FCLK_MUX; TIMEPARAGRANULARITY_X1	C ⁽³⁾ - 2.55	C ⁽³⁾ + 2.65	ns
FA9	$t_{d(\text{a}V\text{-csn}V)}$	Delay time, output address GPMC_A[27:1] valid to output chip select GPMC_CS _n [j] ⁽¹³⁾ valid	div_by_1_mode; GPMC_FCLK_MUX; TIMEPARAGRANULARITY_X1	J ⁽⁹⁾ - 2.55	J ⁽⁹⁾ + 2.65	ns
FA10	$t_{d(\text{be}[x]nV\text{-csn}V)}$	Delay time, output lower-byte enable and command latch enable GPMC_BE0n_CLE, output upper-byte enable GPMC_BE1n valid to output chip select GPMC_CS _n [j] ⁽¹³⁾ valid	div_by_1_mode; GPMC_FCLK_MUX; TIMEPARAGRANULARITY_X1	J ⁽⁹⁾ - 2.55	J ⁽⁹⁾ + 2.65	ns
FA12	$t_{d(\text{csn}V\text{-advn}V)}$	Delay time, output chip select GPMC_CS _n [j] ⁽¹³⁾ valid to output address valid and address latch enable GPMC_ADV _n _ALE valid	div_by_1_mode; GPMC_FCLK_MUX; TIMEPARAGRANULARITY_X1	K ⁽¹⁰⁾ - 2.55	K ⁽¹⁰⁾ + 2.65	ns
FA13	$t_{d(\text{csn}V\text{-oen}V)}$	Delay time, output chip select GPMC_CS _n [j] ⁽¹³⁾ valid to output enable GPMC_OEn_REn valid	div_by_1_mode; GPMC_FCLK_MUX; TIMEPARAGRANULARITY_X1	L ⁽¹¹⁾ - 2.55	L ⁽¹¹⁾ + 2.65	ns
FA16	$t_{w(\text{a}IV)}$	Pulse duration output address GPMC_A[26:1] invalid between 2 successive read and write accesses	div_by_1_mode; GPMC_FCLK_MUX; TIMEPARAGRANULARITY_X1	G ⁽⁷⁾		ns
FA18	$t_{d(\text{csn}V\text{-oen}IV)}$	Delay time, output chip select GPMC_CS _n [j] ⁽¹³⁾ valid to output enable GPMC_OEn_REn invalid (Burst read)	div_by_1_mode; GPMC_FCLK_MUX; TIMEPARAGRANULARITY_X1	I ⁽⁸⁾ - 2.55	I ⁽⁸⁾ + 2.65	ns
FA20	$t_{w(\text{a}V)}$	Pulse duration, output address GPMC_A[27:1] valid - 2nd, 3rd, and 4th accesses	div_by_1_mode; GPMC_FCLK_MUX; TIMEPARAGRANULARITY_X1	D ⁽⁴⁾		ns

NO.	PARAMETER	DESCRIPTION	MODE ⁽¹⁵⁾	MIN	MAX	UNIT
				133 MHz ⁽¹⁶⁾		
FA25	$t_{d(csnV-wenV)}$	Delay time, output chip select GPMC_CS <i>n</i> [<i>j</i>] ⁽¹³⁾ valid to output write enable GPMC_WEn valid	div_by_1_mode; GPMC_FCLK_MUX; TIMEPARAGRANULARITY_X1	E ⁽⁵⁾ - 2.55	E ⁽⁵⁾ + 2.65	ns
FA27	$t_{d(csnV-wenIV)}$	Delay time, output chip select GPMC_CS <i>n</i> [<i>j</i>] ⁽¹³⁾ valid to output write enable GPMC_WEn invalid	div_by_1_mode; GPMC_FCLK_MUX; TIMEPARAGRANULARITY_X1	F ⁽⁶⁾ - 2.55	F ⁽⁶⁾ + 2.65	ns
FA28	$t_{d(wenV-dV)}$	Delay time, output write enable GPMC_WEn valid to output data GPMC_AD[15:0] valid	div_by_1_mode; GPMC_FCLK_MUX; TIMEPARAGRANULARITY_X1		2.65	ns
FA29	$t_{d(dV-csnV)}$	Delay time, output data GPMC_AD[15:0] valid to output chip select GPMC_CS <i>n</i> [<i>j</i>] ⁽¹³⁾ valid	div_by_1_mode; GPMC_FCLK_MUX; TIMEPARAGRANULARITY_X1	J ⁽⁹⁾ - 2.55	J ⁽⁹⁾ + 2.65	ns
FA37	$t_{d(oenV-alV)}$	Delay time, output enable GPMC_OEn_REn valid to output address GPMC_AD[15:0] phase end	div_by_1_mode; GPMC_FCLK_MUX; TIMEPARAGRANULARITY_X1		2.65	ns

- (1) For single read: $A = (CSRdOffTime - CSOnTime) \times (TimeParaGranularity + 1) \times GPMC_FCLK^{(14)}$
 For single write: $A = (CSWrOffTime - CSOnTime) \times (TimeParaGranularity + 1) \times GPMC_FCLK^{(14)}$
 For burst read: $A = (CSRdOffTime - CSOnTime + (n - 1) \times PageBurstAccessTime) \times (TimeParaGranularity + 1) \times GPMC_FCLK^{(14)}$
 For burst write: $A = (CSWrOffTime - CSOnTime + (n - 1) \times PageBurstAccessTime) \times (TimeParaGranularity + 1) \times GPMC_FCLK^{(14)}$
 with n being the page burst access number
- (2) For reading: $B = ((ADVrOffTime - CSOnTime) \times (TimeParaGranularity + 1) + 0.5 \times (ADVExtraDelay - CSEExtraDelay)) \times GPMC_FCLK^{(14)}$
 For writing: $B = ((ADVWrOffTime - CSOnTime) \times (TimeParaGranularity + 1) + 0.5 \times (ADVExtraDelay - CSEExtraDelay)) \times GPMC_FCLK^{(14)}$
- (3) $C = ((OEOffTime - CSOnTime) \times (TimeParaGranularity + 1) + 0.5 \times (OEEExtraDelay - CSEExtraDelay)) \times GPMC_FCLK^{(14)}$
- (4) $D = PageBurstAccessTime \times (TimeParaGranularity + 1) \times GPMC_FCLK^{(14)}$
- (5) $E = ((WEOnTime - CSOnTime) \times (TimeParaGranularity + 1) + 0.5 \times (WEEExtraDelay - CSEExtraDelay)) \times GPMC_FCLK^{(14)}$
- (6) $F = ((WEOffTime - CSOnTime) \times (TimeParaGranularity + 1) + 0.5 \times (WEEExtraDelay - CSEExtraDelay)) \times GPMC_FCLK^{(14)}$
- (7) $G = Cycle2CycleDelay \times GPMC_FCLK^{(14)}$
- (8) $I = ((OEOffTime + (n - 1) \times PageBurstAccessTime - CSOnTime) \times (TimeParaGranularity + 1) + 0.5 \times (OEEExtraDelay - CSEExtraDelay)) \times GPMC_FCLK^{(14)}$
- (9) $J = (CSOnTime \times (TimeParaGranularity + 1) + 0.5 \times CSEExtraDelay) \times GPMC_FCLK^{(14)}$
- (10) $K = ((ADVOnTime - CSOnTime) \times (TimeParaGranularity + 1) + 0.5 \times (ADVExtraDelay - CSEExtraDelay)) \times GPMC_FCLK^{(14)}$
- (11) $L = ((OEOnTime - CSOnTime) \times (TimeParaGranularity + 1) + 0.5 \times (OEEExtraDelay - CSEExtraDelay)) \times GPMC_FCLK^{(14)}$
- (12) For single read: $N = RdCycleTime \times (TimeParaGranularity + 1) \times GPMC_FCLK^{(14)}$
 For single write: $N = WrCycleTime \times (TimeParaGranularity + 1) \times GPMC_FCLK^{(14)}$
 For burst read: $N = (RdCycleTime + (n - 1) \times PageBurstAccessTime) \times (TimeParaGranularity + 1) \times GPMC_FCLK^{(14)}$
 For burst write: $N = (WrCycleTime + (n - 1) \times PageBurstAccessTime) \times (TimeParaGranularity + 1) \times GPMC_FCLK^{(14)}$
- (13) In GPMC_CS*n*[*j*], i is equal to 0, 1, 2 or 3.
- (14) GPMC_FCLK is general-purpose memory controller internal functional clock period in ns.
- (15) For div_by_1_mode:
 - GPMC_CONFIG1_i Register: GPMCFCLKDIVIDER = 0h:
 - GPMC_CLK frequency = GPMC_FCLK frequency
 - CTRLMMR_GPMC_CLKSEL[1-0] CLK_SEL = 00 = CPSWHS DIV_CLKOUT3 = 2000/15 = 133.33 MHz
 - GPMC_CONFIG1_i Register: TIMEPARAGRANULARITY = 0h = x1 latencies (affecting RD/WRCYCLETIME, RD/WRACCESSTIME, PAGEBURSTACCESSTIME, CSONTIME, CSRd/WROFFTIME, ADVONTIME, ADVRD/WROFFTIME, OEONTIME, OEOFFTIME, WEONTIME, WEOFFTIME, CYCLE2CYCLEDELAY, BUSTURNAROUND, TIMEOUTSTARTVALUE, WRDATAONADMUXBUS)
- (16) For 133 MHz:
 - CTRLMMR_GPMC_CLKSEL[1-0] CLK_SEL = 00 = MAIN_PLL0_HSDIV3_CLKOUT

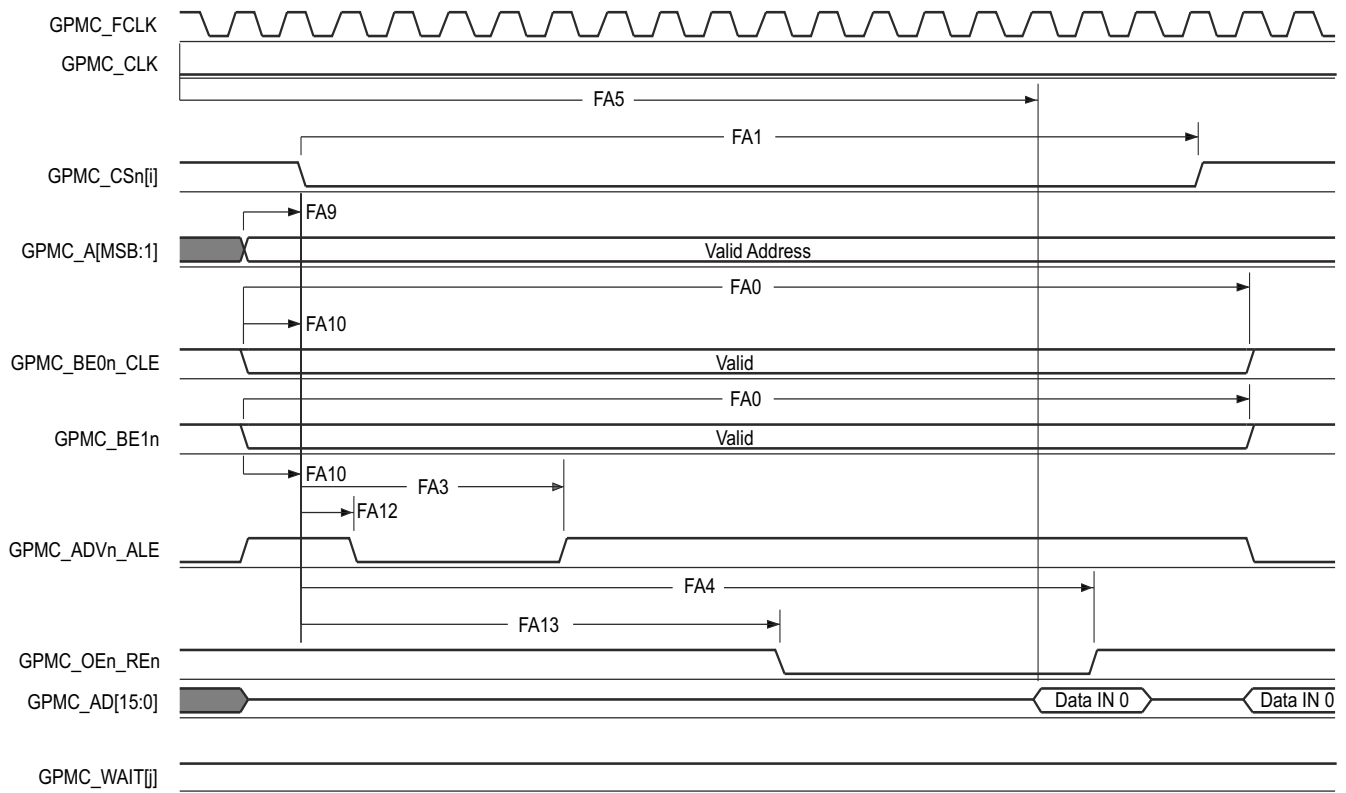

GPMC_06

- A. In GPMC_CS*n*[*i*], *i* is equal to 0, 1, 2 or 3. In GPMC_WAIT[j], *j* is equal to 0, 1, 2, or 3.
- B. FA5 parameter illustrates amount of time required to internally sample input data. It is expressed in number of GPMC functional clock cycles. From start of read cycle and after FA5 functional clock cycles, input data will be internally sampled by active functional clock edge. FA5 value must be stored inside AccessTime register bits field.
- C. GPMC_FCLK is an internal clock (GPMC functional clock) not provided externally.

Figure 6-56. GPMC and NOR Flash — Asynchronous Read — Single Word

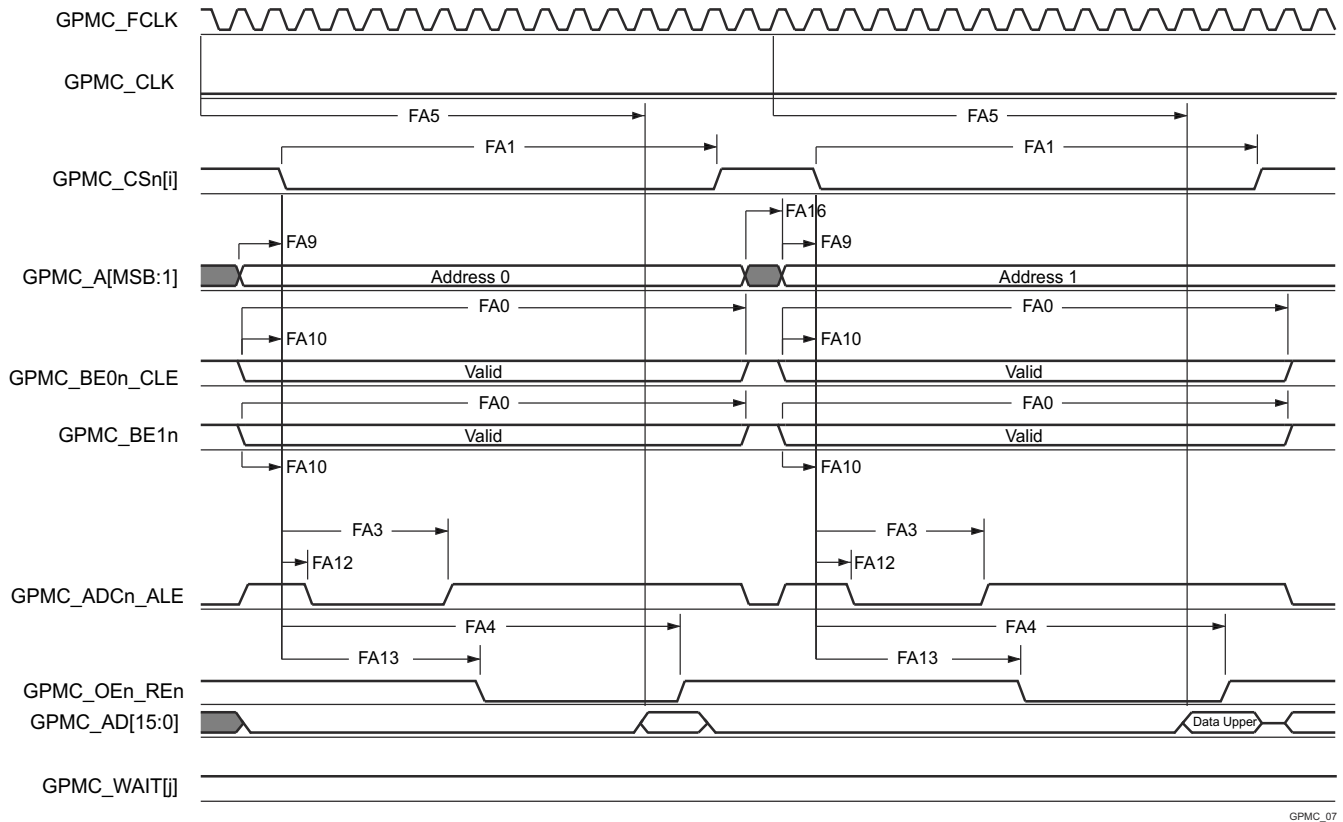

GPMC_07

- A. In GPMC_CS*n*[*i*], *i* is equal to 0, 1, 2 or 3. In GPMC_WAIT[j], *j* is equal to 0, 1, 2, or 3.
- B. FA5 parameter illustrates amount of time required to internally sample input data. It is expressed in number of GPMC functional clock cycles. From start of read cycle and after FA5 functional clock cycles, input data will be internally sampled by active functional clock edge. FA5 value must be stored inside AccessTime register bits field.
- C. GPMC_FCLK is an internal clock (GPMC functional clock) not provided externally.

Figure 6-57. GPMC and NOR Flash — Asynchronous Read — 32-Bit

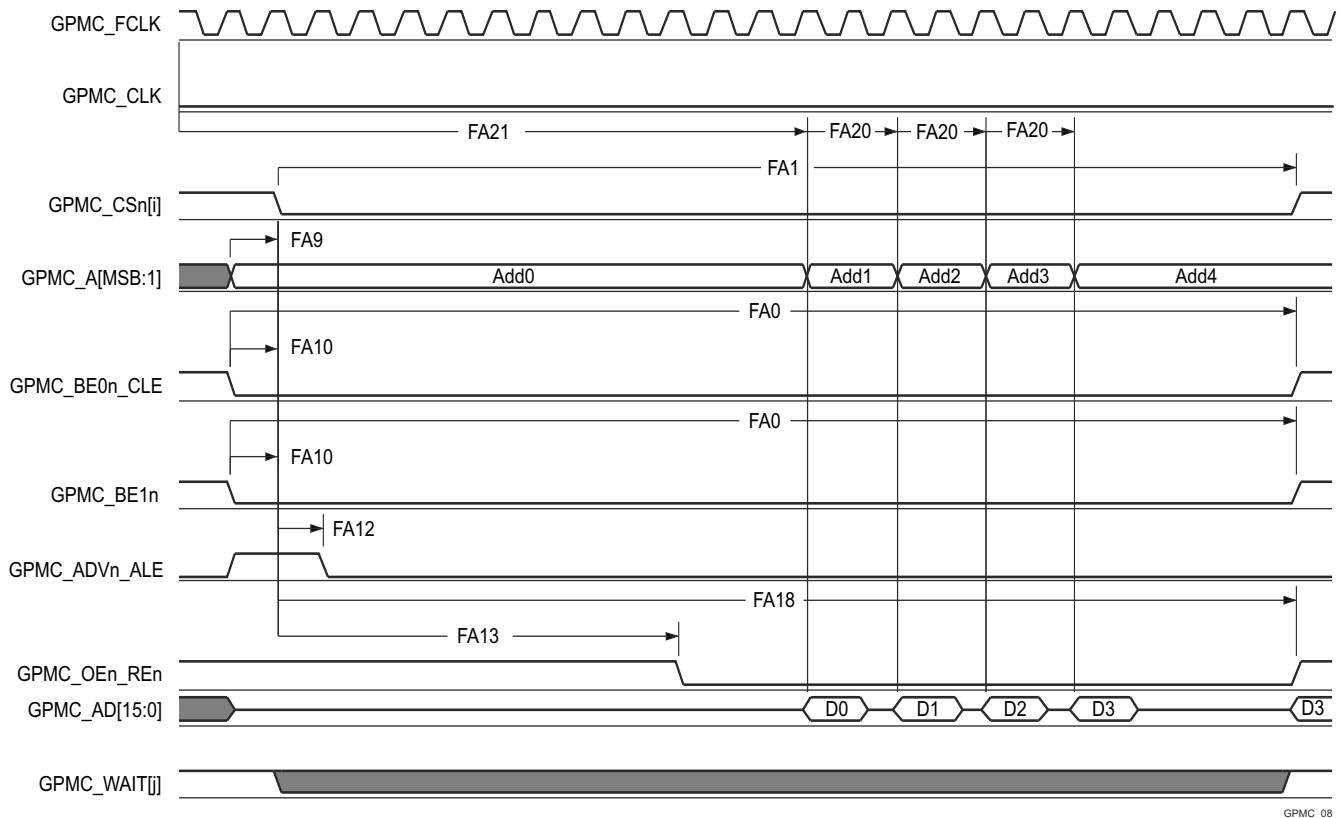

- A. In GPMC_CS*n*[*i*], *i* is equal to 0, 1, 2 or 3. In GPMC_WAIT[j], *j* is equal to 0, 1, 2, or 3.
- B. FA21 parameter illustrates amount of time required to internally sample first input page data. It is expressed in number of GPMC functional clock cycles. From start of read cycle and after FA21 functional clock cycles, first input page data will be internally sampled by active functional clock edge. FA21 calculation must be stored inside AccessTime register bits field.
- C. FA20 parameter illustrates amount of time required to internally sample successive input page data. It is expressed in number of GPMC functional clock cycles. After each access to input page data, next input page data will be internally sampled by active functional clock edge after FA20 functional clock cycles. FA20 is also the duration of address phases for successive input page data (excluding first input page data). FA20 value must be stored in PageBurstAccessTime register bits field.
- D. GPMC_FCLK is an internal clock (GPMC functional clock) not provided externally.

Figure 6-58. GPMC and NOR Flash — Asynchronous Read — Page Mode 4x16-Bit

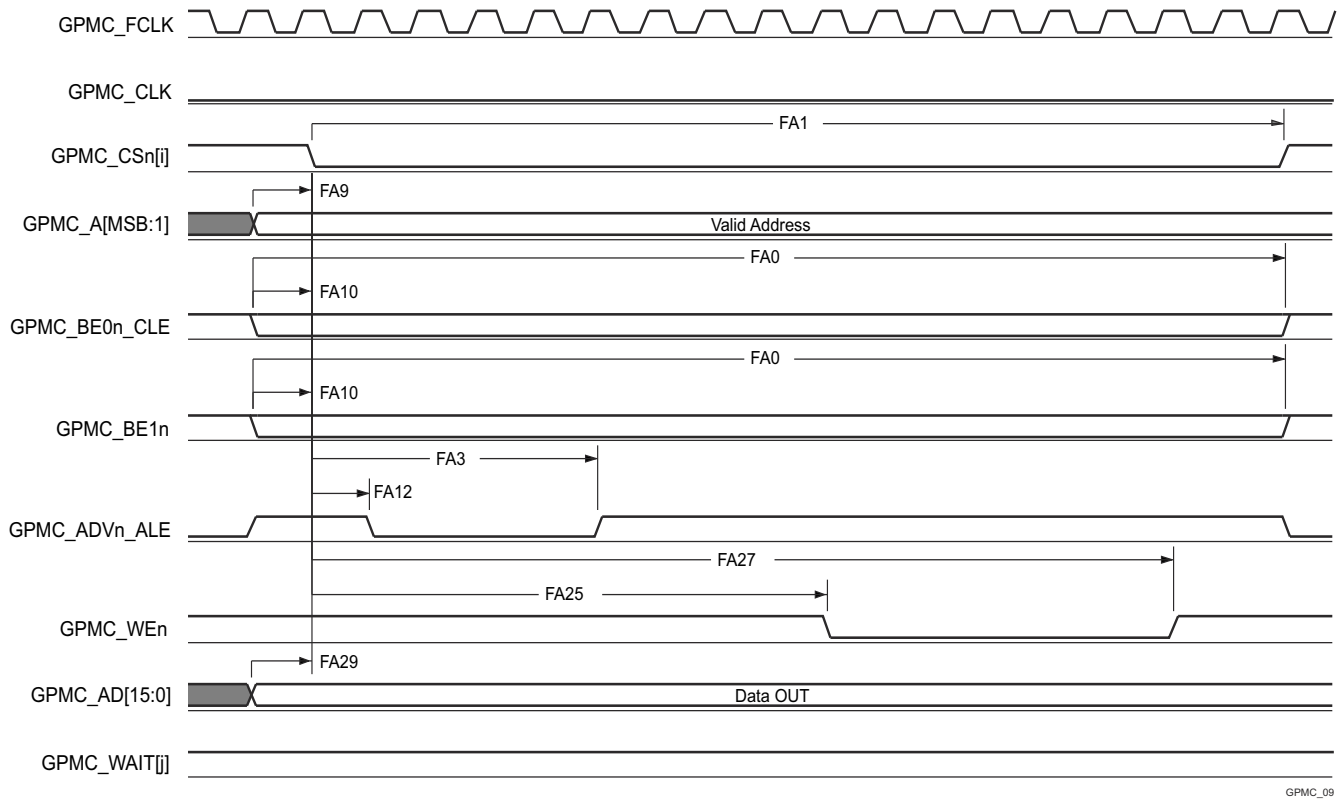

GPMC_09

A. In GPMC_CSn[i], i is equal to 0, 1, 2 or 3. In GPMC_WAIT[j], j is equal to 0, 1, 2, or 3.

Figure 6-59. GPMC and NOR Flash — Asynchronous Write — Single Word

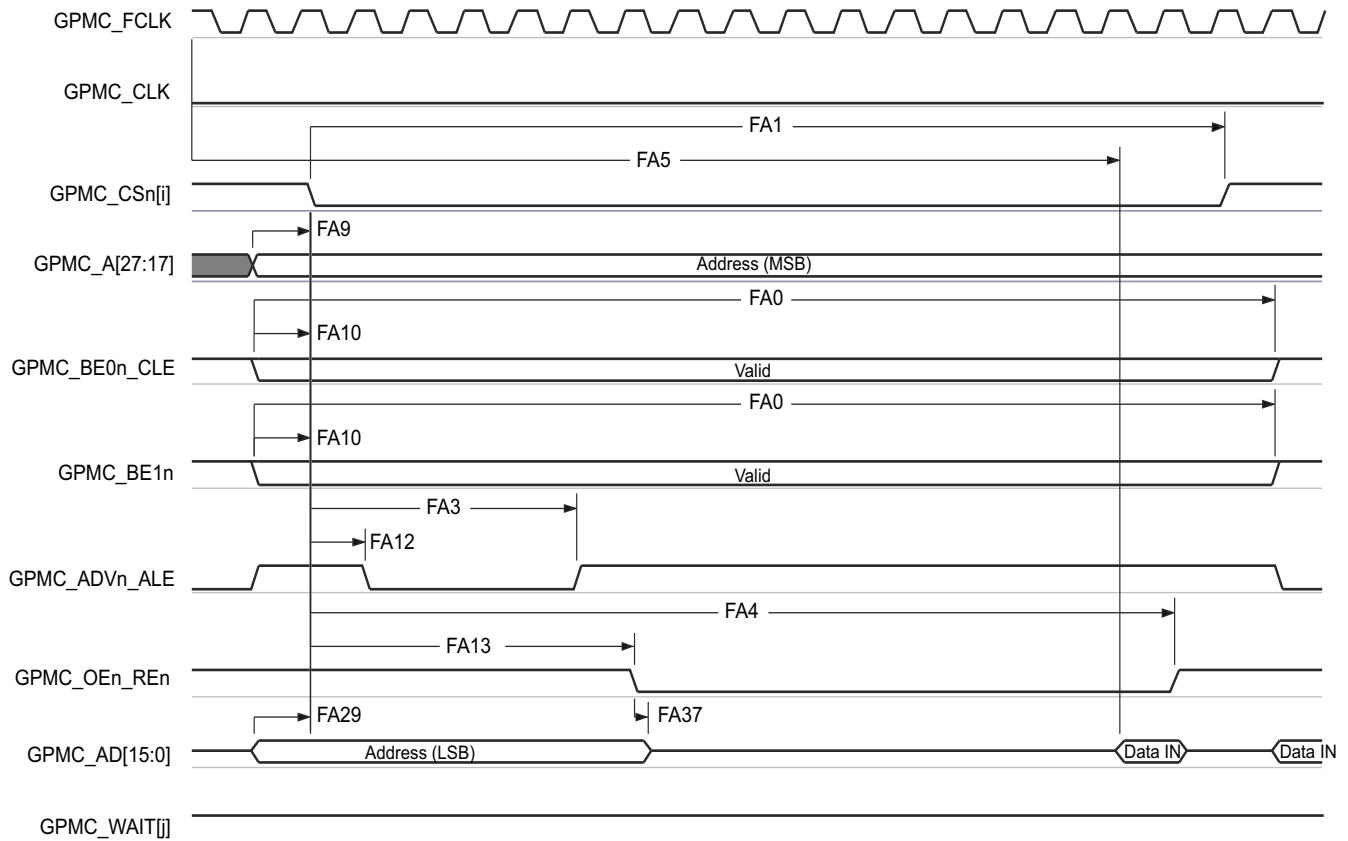

GPMC_10

- A. In GPMC_CSn[i], i is equal to 0, 1, 2 or 3. In GPMC_WAIT[j], j is equal to 0, 1, 2, or 3.
- B. FA5 parameter illustrates amount of time required to internally sample input data. It is expressed in number of GPMC functional clock cycles. From start of read cycle and after FA5 functional clock cycles, input data will be internally sampled by active functional clock edge. FA5 value must be stored inside AccessTime register bits field.
- C. GPMC_FCLK is an internal clock (GPMC functional clock) not provided externally.

Figure 6-60. GPMC and Multiplexed NOR Flash — Asynchronous Read — Single Word

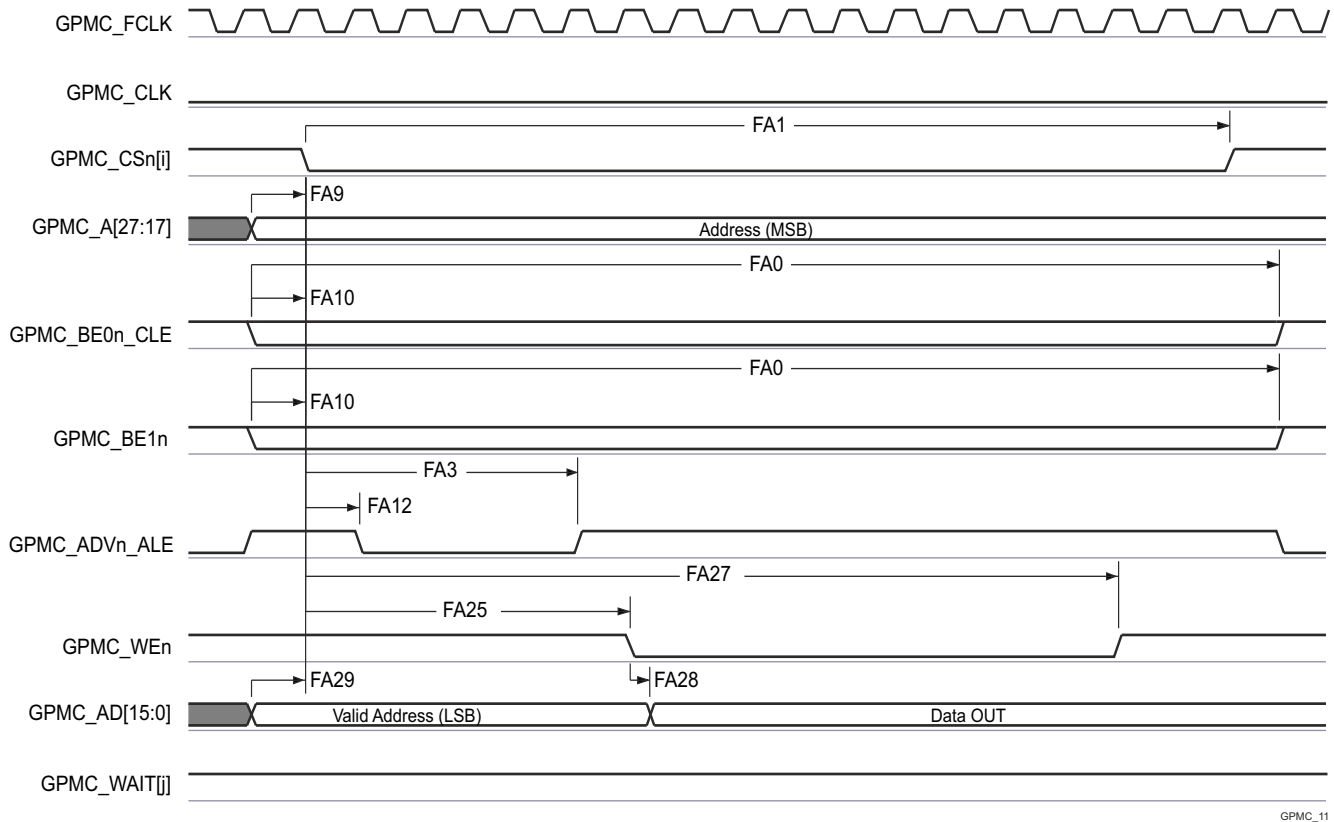

GPMC_11

A. In GPMC_CSn[i], i is equal to 0, 1, 2 or 3. In GPMC_WAIT[j], j is equal to 0, 1, 2, or 3.

Figure 6-61. GPMC and Multiplexed NOR Flash — Asynchronous Write — Single Word

6.10.5.10.3 GPMC and NAND Flash — Asynchronous Mode

Section 6.10.5.10.3.1 and Section 6.10.5.10.3.2 assume testing over the recommended operating conditions and electrical characteristic conditions below (see Figure 6-62 through Figure 6-65).

6.10.5.10.3.1 GPMC and NAND Flash Timing Requirements – Asynchronous Mode

NO.		MODE ⁽⁴⁾	MIN	MAX	UNIT
			133 MHz ⁽⁵⁾		
GNF12 ⁽¹⁾	$t_{acc(d)}$ Access time, input data GPMC_AD[15:0] ⁽³⁾	div_by_1_mode; GPMC_FCLK_MUX; TIMEPARAGRANULARITY_X1		J ⁽²⁾	ns

- (1) The GNF12 parameter illustrates the amount of time required to internally sample input data. It is expressed in number of GPMC functional clock cycles. From start of the read cycle and after GNF12 functional clock cycles, input data is internally sampled by the active functional clock edge. The GNF12 value must be stored inside AccessTime register bit field.
- (2) $J = \text{AccessTime} \times (\text{TimeParaGranularity} + 1) \times \text{GPMC_FCLK}$ ⁽³⁾
- (3) GPMC_FCLK is general-purpose memory controller internal functional clock period in ns.
- (4) For div_by_1_mode:
 - GPMC_CONFIG1_i Register: GPMCFCLKDIVIDER = 0h:
 - GPMC_CLK frequency = GPMC_FCLK frequency
 - CTRLMMR_GPMC_CLKSEL[1-0] CLK_SEL = 00 = CPSWHSDDIV_CLKOUT3 = 2000/15 = 133.33 MHz
 - GPMC_CONFIG1_i Register: TIMEPARAGRANULARITY = 0h = x1 latencies (affecting RD/WRCYCLETIME, RD/WRACCESSTIME, PAGEBURSTACCESSTIME, CSONTIME, CSRD/WROFFTIME, ADVONTIME, ADVRD/WROFFTIME, OEONTIME, OEOFFTIME, WEONTIME, WEOFFTIME, CYCLE2CYCLEDELAY, BUSTURNAROUND, TIMEOUTSTARTVALUE, WRDATAONADMUXBUS)
- (5) For 133 MHz:
 - CTRLMMR_GPMC_CLKSEL[1-0] CLK_SEL = 00 = MAIN_PLL0_HSDIV3_CLKOUT

6.10.5.10.3.2 GPMC and NAND Flash Switching Characteristics – Asynchronous Mode

NO.	PARAMETER	MODE ⁽¹⁵⁾	MIN	MAX	UNIT
			133 MHz ⁽¹⁶⁾		
GNF0	$t_{w(wenV)}$ Pulse duration, output write enable GPMC_WEn valid	div_by_1_mode; GPMC_FCLK_MUX; TIMEPARAGRANULARITY_X1	A ⁽¹⁾		ns
GNF1	$t_{d(csnV-wenV)}$ Delay time, output chip select GPMC_CS <i>n</i> [<i>i</i>] ⁽¹³⁾ valid to output write enable GPMC_WEn valid	div_by_1_mode; GPMC_FCLK_MUX; TIMEPARAGRANULARITY_X1	B ⁽²⁾ - 2.55	B ⁽²⁾⁺ 2.65	ns
GNF2	$t_{w(cleH-wenV)}$ Delay time, output lower-byte enable and command latch enable GPMC_BE0 <i>n</i> _CLE high to output write enable GPMC_WEn valid	div_by_1_mode; GPMC_FCLK_MUX; TIMEPARAGRANULARITY_X1	C ⁽³⁾ - 2.55	C ⁽³⁾⁺ 2.65	ns
GNF3	$t_{w(wenV-dV)}$ Delay time, output data GPMC_AD[15:0] valid to output write enable GPMC_WEn valid	div_by_1_mode; GPMC_FCLK_MUX; TIMEPARAGRANULARITY_X1	D ⁽⁴⁾ - 2.55	D ⁽⁴⁾⁺ 2.65	ns
GNF4	$t_{w(wenIV-dIV)}$ Delay time, output write enable GPMC_WEn invalid to output data GPMC_AD[15:0] invalid	div_by_1_mode; GPMC_FCLK_MUX; TIMEPARAGRANULARITY_X1	E ⁽⁵⁾ - 2.55	E ⁽⁵⁾⁺ 2.65	ns
GNF5	$t_{w(wenIV-cleIV)}$ Delay time, output write enable GPMC_WEn invalid to output lower-byte enable and command latch enable GPMC_BE0 <i>n</i> _CLE invalid	div_by_1_mode; GPMC_FCLK_MUX; TIMEPARAGRANULARITY_X1	F ⁽⁶⁾ - 2.55	F ⁽⁶⁾⁺ 2.65	ns

NO.	PARAMETER		MODE ⁽¹⁵⁾	MIN	MAX	UNIT
				133 MHz ⁽¹⁶⁾		
GNF6	$t_{w(wenIV-CSn[i])}$	Delay time, output write enable GPMC_WEn invalid to output chip select GPMC_CS <i>n</i> [<i>i</i>] ⁽¹³⁾ invalid	div_by_1_mode; GPMC_FCLK_MUX; TIMEPARAGRANULARITY_X1	G ⁽⁷⁾ - 2.55	G ⁽⁷⁾⁺ 2.65	ns
GNF7	$t_{w(aleH-wenV)}$	Delay time, output address valid and address latch enable GPMC_ADV <i>n</i> _ALE high to output write enable GPMC_WEn valid	div_by_1_mode; GPMC_FCLK_MUX; TIMEPARAGRANULARITY_X1	C ⁽³⁾ - 2.55	C ⁽³⁾⁺ 2.65	ns
GNF8	$t_{w(wenIV-aleIV)}$	Delay time, output write enable GPMC_WEn invalid to output address valid and address latch enable GPMC_ADV <i>n</i> _ALE invalid	div_by_1_mode; GPMC_FCLK_MUX; TIMEPARAGRANULARITY_X1	F ⁽⁶⁾ - 2.55	F ⁽⁶⁾⁺ 2.65	ns
GNF9	$t_{c(wen)}$	Cycle time, write	div_by_1_mode; GPMC_FCLK_MUX; TIMEPARAGRANULARITY_X1		H ⁽⁸⁾	ns
GNF10	$t_{d(csnV-oenV)}$	Delay time, output chip select GPMC_CS <i>n</i> [<i>i</i>] ⁽¹³⁾ valid to output enable GPMC_OEn_RE <i>n</i> valid	div_by_1_mode; GPMC_FCLK_MUX; TIMEPARAGRANULARITY_X1	I ⁽⁹⁾ - 2.55	I ⁽⁹⁾⁺ 2.65	ns
GNF13	$t_{w(oenV)}$	Pulse duration, output enable GPMC_OEn_RE <i>n</i> valid	div_by_1_mode; GPMC_FCLK_MUX; TIMEPARAGRANULARITY_X1		K ⁽¹⁰⁾	ns
GNF14	$t_{c(oen)}$	Cycle time, read	div_by_1_mode; GPMC_FCLK_MUX; TIMEPARAGRANULARITY_X1	L ⁽¹¹⁾		ns
GNF15	$t_{w(oenIV-CSn[i])}$	Delay time, output enable GPMC_OEn_RE <i>n</i> invalid to output chip select GPMC_CS <i>n</i> [<i>i</i>] ⁽¹³⁾ invalid	div_by_1_mode;	M ⁽¹²⁾ - 2.55	M ⁽¹²⁾⁺ 2.65	ns

- (1) $A = (WEOffTime - WEOnTime) \times (TimeParaGranularity + 1) \times GPMC_FCLK^{(14)}$
- (2) $B = ((WEOnTime - CSOnTime) \times (TimeParaGranularity + 1) + 0.5 \times (WEEExtraDelay - CSEExtraDelay)) \times GPMC_FCLK^{(14)}$
- (3) $C = ((WEOnTime - ADVOnTime) \times (TimeParaGranularity + 1) + 0.5 \times (WEEExtraDelay - ADVExtraDelay)) \times GPMC_FCLK^{(14)}$
- (4) $D = (WEOnTime \times (TimeParaGranularity + 1) + 0.5 \times WEEExtraDelay) \times GPMC_FCLK^{(14)}$
- (5) $E = ((WrCycleTime - WEOffTime) \times (TimeParaGranularity + 1) - 0.5 \times WEEExtraDelay) \times GPMC_FCLK^{(14)}$
- (6) $F = ((ADVWrOffTime - WEOffTime) \times (TimeParaGranularity + 1) + 0.5 \times (ADVExtraDelay - WEEExtraDelay)) \times GPMC_FCLK^{(14)}$
- (7) $G = ((CSWrOffTime - WEOffTime) \times (TimeParaGranularity + 1) + 0.5 \times (CSEExtraDelay - WEEExtraDelay)) \times GPMC_FCLK^{(14)}$
- (8) $H = WrCycleTime \times (1 + TimeParaGranularity) \times GPMC_FCLK^{(14)}$
- (9) $I = ((OEOntime - CSOnTime) \times (TimeParaGranularity + 1) + 0.5 \times (OEEExtraDelay - CSEExtraDelay)) \times GPMC_FCLK^{(14)}$
- (10) $K = (OEOffTime - OEOnTime) \times (1 + TimeParaGranularity) \times GPMC_FCLK^{(14)}$
- (11) $L = RdCycleTime \times (1 + TimeParaGranularity) \times GPMC_FCLK^{(14)}$
- (12) $M = ((CSRdOffTime - OEOffTime) \times (TimeParaGranularity + 1) + 0.5 \times (CSEExtraDelay - OEEExtraDelay)) \times GPMC_FCLK^{(14)}$
- (13) In GPMC_CS*n*[*i*], *i* is equal to 0, 1, 2 or 3.
- (14) GPMC_FCLK is general-purpose memory controller internal functional clock period in ns.
- (15) For div_by_1_mode:
- GPMC_CONFIG1_i Register: GPMCFCLKDIVIDER = 0h:
 - GPMC_CLK frequency = GPMC_FCLK frequency
- For GPMC_FCLK_MUX:
- CTRLMMR_GPMC_CLKSEL[1-0] CLK_SEL = 00 = CPSWHSIDIV_CLKOUT3 = 2000/15 = 133.33 MHz
- For TIMEPARAGRANULARITY_X1:
- GPMC_CONFIG1_i Register: TIMEPARAGRANULARITY = 0h = x1 latencies (affecting RD/WRCYCLETIME, RD/WRACCESSTIME, PAGEBURSTACCESSTIME, CSONTIME, CSRd/WROFFTIME, ADVONTIME, ADVRD/WROFFTIME, OEONTIME, OEOFFTIME, WEONTIME, WEOFFTIME, CYCLE2CYCLEDELAY, BUSTURNAROUND, TIMEOUTSTARTVALUE, WRDATAONADMUXBUS)
- (16) For 133 MHz:
- CTRLMMR_GPMC_CLKSEL[1-0] CLK_SEL = 00 = MAIN_PLL0_HSDIV3_CLKOUT

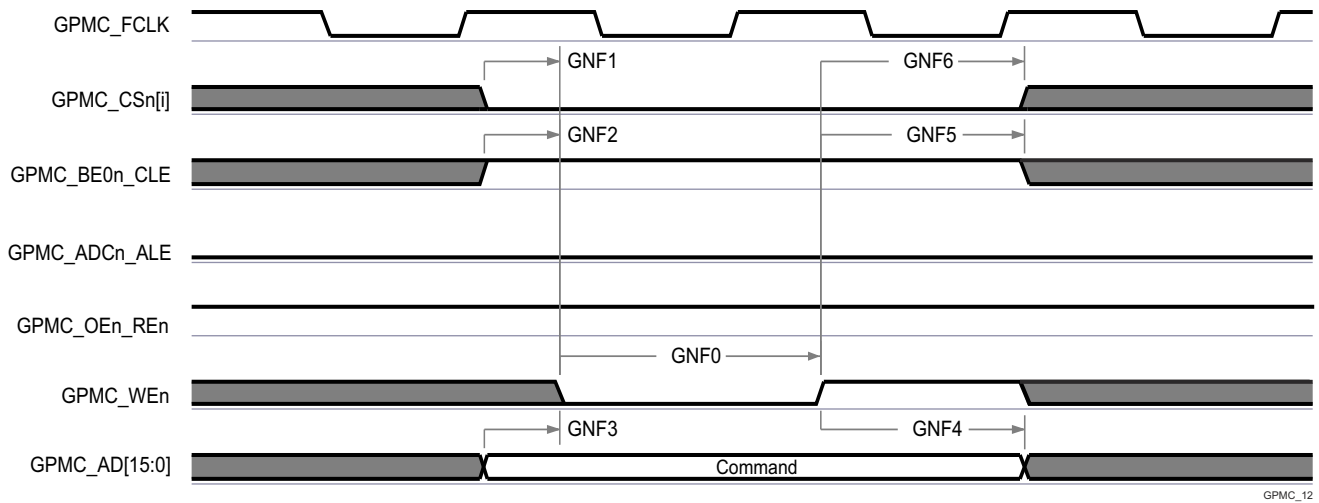

GPMC_12

A. In GPMC_CSn[i], i is equal to 0, 1, 2 or 3.

Figure 6-62. GPMC and NAND Flash — Command Latch Cycle

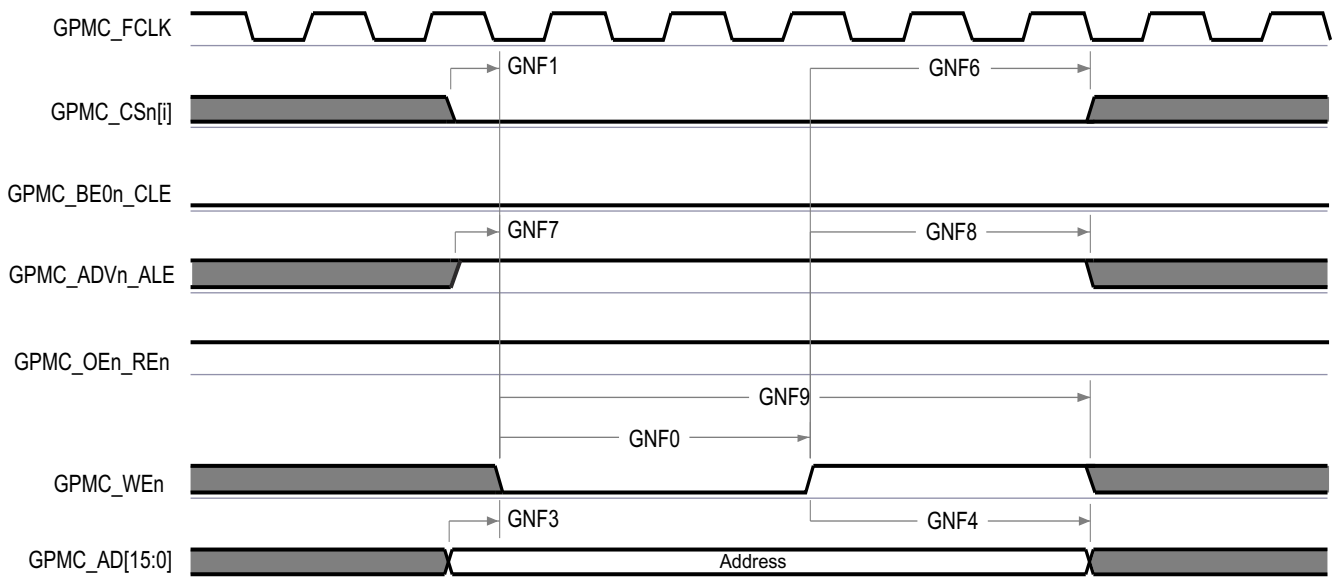

GPMC_13

A. In GPMC_CSn[i], i is equal to 0, 1, 2 or 3.

Figure 6-63. GPMC and NAND Flash — Address Latch Cycle

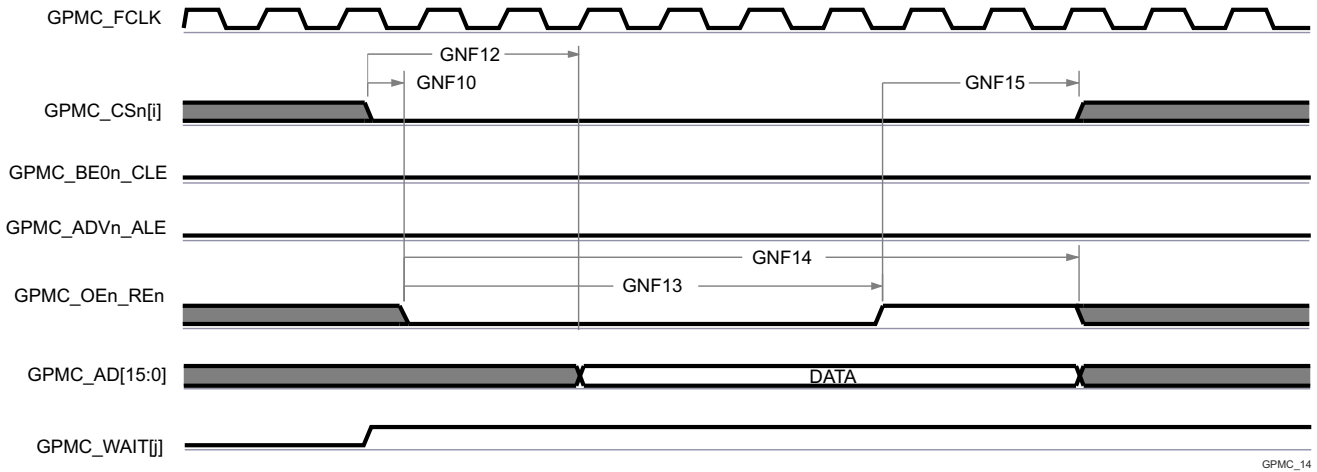

GPMC_14

- A. GNF12 parameter illustrates amount of time required to internally sample input data. It is expressed in number of GPMC functional clock cycles. From start of read cycle and after GNF12 functional clock cycles, input data will be internally sampled by active functional clock edge. GNF12 value must be stored inside AccessTime register bits field.
- B. GPMC_FCLK is an internal clock (GPMC functional clock) not provided externally.
- C. In GPMC_CS*n*[*i*], *i* is equal to 0, 1, 2 or 3. In GPMC_WAIT[j], *j* is equal to 0, 1, 2, or 3.

Figure 6-64. GPMC and NAND Flash — Data Read Cycle

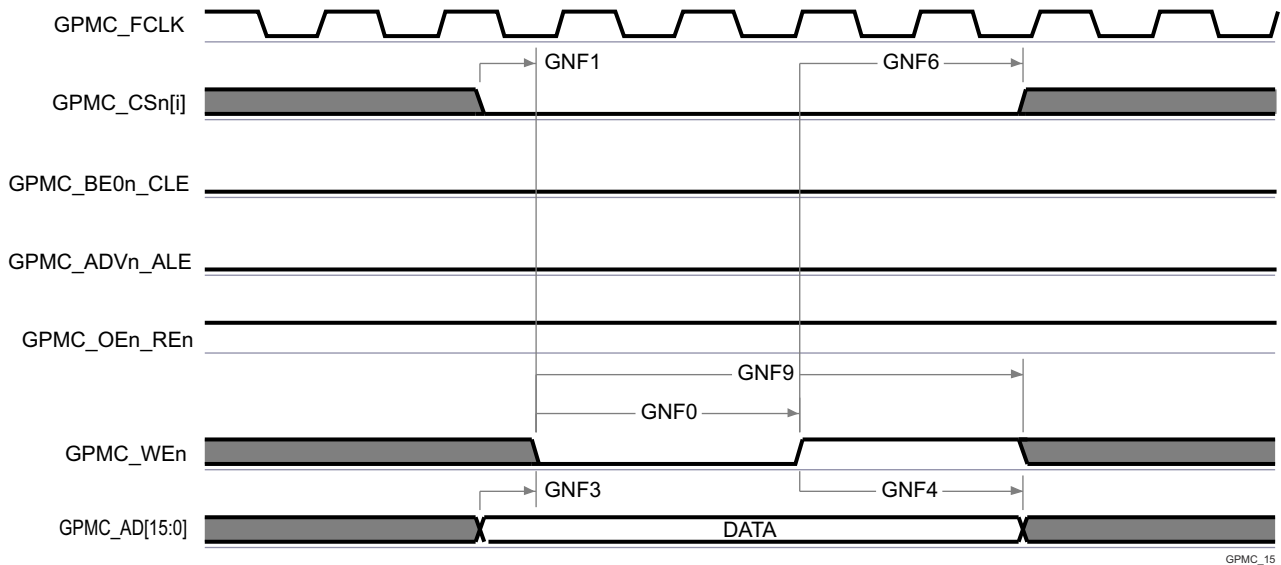

GPMC_15

- A. In GPMC_CS*n*[*i*], *i* is equal to 0, 1, 2 or 3.

Figure 6-65. GPMC and NAND Flash — Data Write Cycle

For more information, see *Enhanced Pulse Width Modulation (EPWM) Module* section in *Peripherals* chapter in the device TRM.

6.10.5.10.4 GPMC0 IOSET

Table 6-40 present the specific groupings of signals (IOSET) for use with GPMC0.

Table 6-40. GPMC0 IOSET

Signals	IOSET1		IOSET2	
	BALL NAME	MUX	BALL NAME	MUX
GPMC0_WAIT2	MDIO0_MDC	8	MDIO0_MDC	8
GPMC0_BE1n	PRG1_PRU0_GPO0	8	RGMII6_RD1	8

Table 6-40. GPMC0 IOSET (continued)

Signals	IOSET1		IOSET2	
	BALL NAME	MUX	BALL NAME	MUX
GPMC0_WAIT0	PRG1_PRU0_GPO1	8	PRG1_PRU0_GPO1	8
GPMC0_WAIT1	PRG1_PRU0_GPO2	8	PRG1_PRU0_GPO2	8
GPMC0_DIR	PRG1_PRU0_GPO3	8	PRG1_PRU0_GPO3	8
GPMC0_CSn2	PRG1_PRU0_GPO4	8	PRG1_PRU0_GPO4	8
GPMC0_WEn	PRG1_PRU0_GPO5	8	PRG1_PRU0_GPO5	8
GPMC0_CSn3	PRG1_PRU0_GPO6	8	PRG1_PRU0_GPO6	8
GPMC0_OEn_REn	PRG1_PRU0_GPO8	8	PRG1_PRU0_GPO8	8
GPMC0_ADVh_ALE	PRG1_PRU0_GPO9	8	PRG1_PRU0_GPO9	8
GPMC0_BE0n_CLE	PRG1_PRU0_GPO10	8	PRG1_PRU0_GPO10	8
GPMC0_WPn	PRG1_PRU1_GPO5	8	PRG1_PRU1_GPO5	8
GPMC0_CSn1	PRG1_PRU1_GPO8	8	PRG1_PRU1_GPO8	8
GPMC0_CSn0	PRG1_PRU1_GPO9	8	PRG1_PRU1_GPO9	8
GPMC0_CLKOUT	PRG1_PRU1_GPO10	8	PRG1_PRU1_GPO10	8
GPMC0_AD0	PRG0_PRU0_GPO5	8	PRG0_PRU0_GPO5	8
GPMC0_AD1	PRG0_PRU0_GPO7	8	PRG0_PRU0_GPO7	8
GPMC0_AD2	PRG0_PRU0_GPO8	8	PRG0_PRU0_GPO8	8
GPMC0_AD3	PRG0_PRU0_GPO9	8	PRG0_PRU0_GPO9	8
GPMC0_AD4	PRG0_PRU0_GPO10	8	PRG0_PRU0_GPO10	8
GPMC0_AD5	PRG0_PRU0_GPO17	8	PRG0_PRU0_GPO17	8
GPMC0_AD6	PRG0_PRU0_GPO18	8	PRG0_PRU0_GPO18	8
GPMC0_AD7	PRG0_PRU0_GPO19	8	PRG0_PRU0_GPO19	8
GPMC0_AD8	PRG0_PRU1_GPO5	8	PRG0_PRU1_GPO5	8
GPMC0_AD9	PRG0_PRU1_GPO7	8	PRG0_PRU1_GPO7	8
GPMC0_AD10	PRG0_PRU1_GPO8	8	PRG0_PRU1_GPO8	8
GPMC0_AD11	PRG0_PRU1_GPO9	8	PRG0_PRU1_GPO9	8
GPMC0_AD12	PRG0_PRU1_GPO10	8	PRG0_PRU1_GPO10	8
GPMC0_AD13	PRG0_PRU1_GPO17	8	PRG0_PRU1_GPO17	8
GPMC0_AD14	PRG0_PRU1_GPO18	8	PRG0_PRU1_GPO18	8
GPMC0_AD15	PRG0_PRU1_GPO19	8	PRG0_PRU1_GPO19	8
GPMC0_A0	PRG0_MDIO0_MDC	8	PRG0_MDIO0_MDC	8
GPMC0_A1	RGMII5_TX_CTL	8	RGMII5_TX_CTL	8
GPMC0_A2	RGMII5_RX_CTL	8	RGMII5_RX_CTL	8
GPMC0_A3	RGMII5_TD3	8	RGMII5_TD3	8
GPMC0_A4	RGMII5_TD2	8	RGMII5_TD2	8
GPMC0_A5	RGMII5_TD1	8	RGMII5_TD1	8
GPMC0_A6	RGMII5_TD0	8	RGMII5_TD0	8
GPMC0_A7	RGMII5_TXC	8	RGMII5_TXC	8
GPMC0_A8	RGMII5_RXC	8	RGMII5_RXC	8
GPMC0_A9	RGMII5_RD3	8	RGMII5_RD3	8
GPMC0_A10	RGMII5_RD2	8	RGMII5_RD2	8
GPMC0_A11	RGMII5_RD1	8	RGMII5_RD1	8
GPMC0_A12	RGMII5_RD0	8	RGMII5_RD0	8
GPMC0_A13	RGMII6_TX_CTL	8	RGMII6_TX_CTL	8
GPMC0_A14	RGMII6_RX_CTL	8	RGMII6_RX_CTL	8

Table 6-40. GPMC0 IOSET (continued)

Signals	IOSET1		IOSET2	
	BALL NAME	MUX	BALL NAME	MUX
GPMC0_A15	RGMII6_TD3	8	RGMII6_TD3	8
GPMC0_A16	RGMII6_TD2	8	RGMII6_TD2	8
GPMC0_A17	RGMII6_TD1	8	RGMII6_TD1	8
GPMC0_A18	RGMII6_TD0	8	RGMII6_TD0	8
GPMC0_A19	RGMII6_TXC	8	RGMII6_TXC	8
GPMC0_A20	RGMII6_RXC	8	RGMII6_RXC	8
GPMC0_A21	RGMII6_RD3	8	RGMII6_RD3	8
GPMC0_A22	RGMII6_RD2	8	RGMII6_RD2	8
GPMC0_A23	PRG0_PRU1_GPO2	8	PRG0_PRU1_GPO2	8
GPMC0_A24	PRG0_PRU1_GPO4	8	PRG0_PRU1_GPO4	8
GPMC0_A25	PRG0_PRU1_GPO6	8	PRG0_PRU1_GPO6	8
GPMC0_A26	PRG0_PRU1_GPO11	8	PRG0_PRU1_GPO11	8
GPMC0_A27	PRG0_MDIO0_MDIO	8	PRG0_MDIO0_MDIO	8
GPMC0_WAIT3	MDIO0_MDIO	8	MDIO0_MDIO	8

6.10.5.11 HyperBus

For more details about features and additional description information on the device HyperBus, see the corresponding sections within [Signal Descriptions](#) and [Detailed Description](#).

[Section 6.10.5.11](#), [Section 6.10.5.11.2](#), and [Section 6.10.5.11.3](#) assume testing over the recommended operating conditions and electrical characteristic conditions (see [Figure 6-66](#), [Figure 6-67](#), and [Figure 6-68](#)).

[Table 6-41](#) represents HyperBus timing conditions.

Table 6-41. HyperBus Timing Conditions

PARAMETER	DESCRIPTION	MIN	MAX	UNIT
INPUT CONDITIONS				
SR _i	Input slew rate	2	5	V/ns
OUTPUT CONDITIONS				
C _L	Output load capacitance	1.5	8	pF

6.10.5.11.1 Timing Requirements for HyperBus

NO.	PARAMETER	DESCRIPTION	MIN	MAX	UNIT
D1	t _w (RESETn)	Pulse width, RESETn	200		ns
D2	t _w (csL)	Pulse width, Chip Select	1000		ns
D3	t _d (RESETnH-csL)	Delay time, RESETn inactive to CSn active	200.34		ns
D4	t _d (csL-RWDSL)	Delay time, CSn active to RWDS falling	115		ns

6.10.5.11.2 HyperBus 166 MHz Switching Characteristics

NO.	PARAMETER	DESCRIPTION	MIN	MAX	UNIT
D5	t _{skn} (rwdsX-dV)	Input skew, RWDS transitioning to D0:D7 valid	-0.46	0.46	ns
D6	t _c (clk/clkn)	CLK period, CLK/CLKn	6		ns
D7	t _w (clk/clkn)	Pulse width, CLK/CLKn	2.7		ns
D8	t _w (csIV)	Pulse width, CS0 invalid between operations	6		ns
D9	t _d (clkH-csL)	Delay time, CS0 active to CLK rising/ CLKn falling		-3.34	ns
D10	t _d (clkL[LE]-csH)	Delay time, last falling CLK/ rising CLKn edge to CS0 inactive	0.41		ns
D11	t _d (clkX-rwdsV)	Delay time, CLK transition to RWDS valid	1.01	2.08	ns

NO.	PARAMETER	DESCRIPTION	MIN	MAX	UNIT
D12	$t_{d(\text{clkX-d}[0:7]V)}$	Delay time, CLK transitioning to D0:D7 valid	0.84	2.17	ns

6.10.5.11.3 HyperBus 100 MHz Switching Characteristics

NO.	PARAMETER	DESCRIPTION	MIN	MAX	UNIT
LFD5	$t_{\text{skn}(\text{rwdsX-dV})}$	Input skew, RWDS transitioning to D0:D7 valid	-0.81	0.81	ns
LFD6	$t_{c(\text{clk})}$	CLK period, CLK	10		ns
LFD7	$t_{w(\text{clk})}$	Pulse width, CLK	4.75		ns
LFD8	$t_{w(\text{csIV})}$	Pulse width, CS0 invalid between operations	10		ns
LFD9	$t_{d(\text{clkH-csL})}$	Delay time, CS0 active to CLK rising		-3.51	ns
LFD10	$t_{d(\text{clkL[LE]-csH})}$	Delay time, last falling CLK edge to CS0 inactive	0.51		ns
LFD11	$t_{d(\text{clkX-rwdsV})}$	Delay time, CLK transition to RWDS valid	1.51	3.49	ns
LFD12	$t_{d(\text{clkX-d}[0:7]V)}$	Delay time, CLK transitioning to D0:D7 valid	1.34	3.66	ns

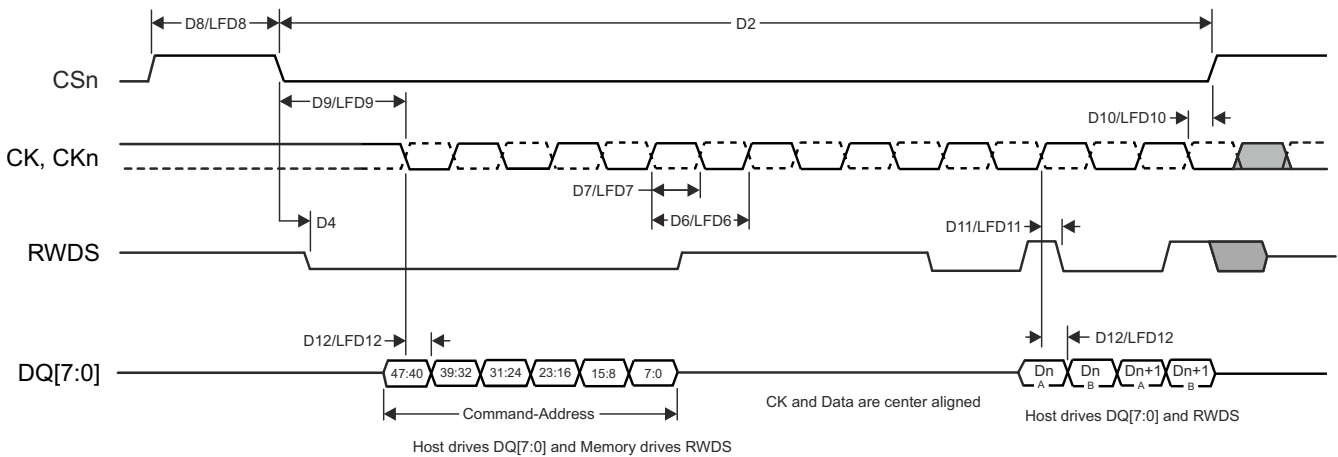

HYPERBUS_TIMING_01

Figure 6-66. HyperBus Timing Diagrams – Transmitter Mode

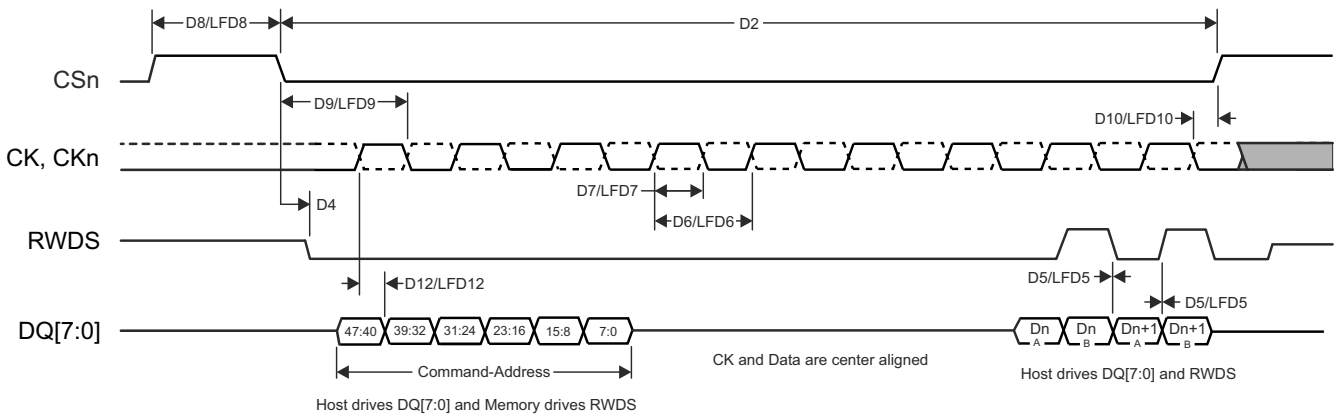

HYPERBUS_TIMING_02

Figure 6-67. HyperBus Timing Diagrams – Receiver Mode

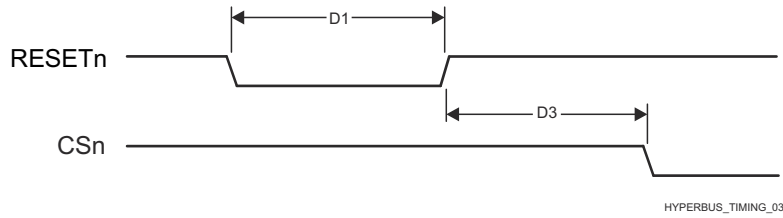

Figure 6-68. HyperBus Timing Diagrams – Reset

For more information, see *HyperBus Interface* section in *Peripherals* chapter in the device TRM.

6.10.5.12 I2C

The device contains **several** multicontroller Inter-Integrated Circuit (I2C) controllers. Each I2C controller was designed to be compliant to the Philips I2C-bus™ specification version 2.1. However, the device **IO Buffers** are not fully compliant to the I2C electrical specification. **Some I2C instances use the LVCMOS Buffer Type, while other instances use the I2S OD FS Buffer type. See the Pin Attributes table to determine the IO Buffer Type used for each I2C instance on this device.** The I2C speeds supported and exceptions are described per **IO Buffer Type** below:

- I2C instances that use the LVCMOS buffer type
 - Speeds:
 - Standard-mode (up to 100 Kbits/s)
 - 1.8 V
 - 3.3 V
 - Fast-mode (up to 400 Kbits/s)
 - 1.8 V
 - 3.3 V
 - Exceptions:
 - The IOs associated with these ports are not compliant to the fall time requirements defined in the I2C specification because they are implemented with higher performance LVCMOS push-pull IOs that were designed to support other signal functions that could not be implemented with I2C compatible IOs. The LVCMOS IOs being used on these ports are connected such they emulate open-drain outputs. This emulation is achieved by forcing a constant low output and disabling the output buffer to enter the Hi-Z state.
 - The I2C specification defines a maximum input voltage V_{IH} of $(V_{DD_{max}} + 0.5 V)$, which exceeds the absolute maximum ratings for the device IOs. The system must be designed to ensure the I2C signals never exceed the limits defined in the [Absolute Maximum Ratings](#) section of this data sheet.
- I2C instances that use the I2C OD FS buffer type
 - Speeds:
 - Standard-mode (up to 100 Kbits/s)
 - 1.8 V
 - 3.3 V
 - Fast-mode (up to 400 Kbits/s)
 - 1.8 V
 - 3.3 V
 - Hs-mode (up to 3.4 Mbit/s)
 - 1.8 V
 - Exceptions:
 - The IOs associated with these ports were not design to support Hs-mode while operating at 3.3 V. So Hs-mode is limited to 1.8-V operation.
 - The rise and fall times of the I2C signals connected to these ports must not exceed a slew rate of 0.8 V/ns (or $8E+7 V/s$). This limit is more restrictive than the minimum fall time limits defined in the I2C

specification. Therefore, it may be necessary to add additional capacitance to the I2C signals to slow the rise and fall times such that they do not exceed a slew rate of 0.8 V/ns.

- The I2C specification defines a maximum input voltage V_{IH} of $(V_{DD_{max}} + 0.5 \text{ V})$, which exceeds the absolute maximum ratings for the device IOs. The system must be designed to ensure the I2C signals never exceed the limits defined in the [Absolute Maximum Ratings](#) section of this data sheet.

Refer to the Philips I2C-bus specification version 2.1 for timing details.

For more details about features and additional description information on the device Inter-Integrated Circuit, see the corresponding subsections within [Section 5.3](#) and *Detailed Description*.

6.10.5.13 I3C

For more details about features and additional description information on the device Inter-Integrated Circuit, see the corresponding sections within [Signal Descriptions](#) and *Detailed Description*.

[Table 6-42](#), [Table 6-43](#), [Figure 6-69](#), [Table 6-44](#), and [Figure 6-70](#) assume testing over the recommended operating conditions and electrical characteristic conditions.

Table 6-42. I3C Open Drain Timing Conditions

PARAMETER		MIN	MAX	UNIT
INPUT CONDITIONS				
SR_i	Input slew rate	0.2276	5	V/ns
OUTPUT CONDITIONS				
C_L	Output load capacitance		50	pF

Table 6-43. I3C Open Drain Timing Parameters

NO.	PARAMETER	DESCRIPTION	MODE	MIN	MAX	UNIT
D1	t_{LOW_OD}	Low Period of SCL Clock	Controller	200		ns
	$t_{DIG_OD_L}$			$t_{LOW_OD\ MIN} + t_{FDA_OD\ MIN}$		ns
D2	t_{HIGH}	High Period of SCL Clock	Controller		41	ns
	t_{DIG_H}			$t_{HIGH} + t_{CF}$		ns
D3	t_{FDA_OD}	Fall Time of SDA Signal	Controller, Target	t_{CF}	12	ns
D4	t_{SU_OD}	SDA Data Setup Time During Open Drain Mode	Controller, Target	3		ns
D5	t_{CAS}	Clock After START (S) Condition	Controller, ENTAS0	38.4	1000	ns
			Controller, ENTAS1	38.4	100000	ns
			Controller, ENTAS2	38.4	2000000	ns
			Controller, ENTAS3	38.4	5000000	ns
D6	t_{CBP}	Clock Before STOP (P) Condition	Controller	$t_{CAS\ MIN} / 2$		ns
D7	$t_{MMOVERLAP}$	Current Controller to Secondary Controller Overlap time during handoff	Controller	$t_{DIG_OD_L\ min}$		ns
D8	t_{AVAL}	Bus Available Condition	Controller	1000		ns
D9	t_{IDLE}	Bus Idle Condition	Controller	1000000		ns
D10	t_{MMLOCK}	Time Interval Where New Controller Not Driving SDA Low	Controller	$t_{AVAL\ min}$		ns

- This is approximately equal to $t_{LOW\ min} + t_{DS_OD\ min} + t_{rDA_OD\ typ} + t_{SU_OD\ min}$.

- The Controller may use a shorter Low period if the Controller knows that this is safe, when SDA is already above V_{IH} .
- Based on t_{SPIKE} , rise and fall times, and interconnect.
- This maximum High period may be exceeded when the signals can be safely seen by Legacy I2C Devices, and/or in consideration of the interconnect (for example: a short Bus).
- On a Legacy Bus where I2C Devices need to see Start, the t_{CAS} Min value is further constrained.
- Targets that do not support the optional ENTASx CCCs shall use the t_{CAS} Max value shown for ENTAS3.
- On a Mixed Bus with Fm Legacy I2C Devices, t_{AVAIL} is 300ns shorter than the Fm Bus Free Condition time (t_{BUF}).

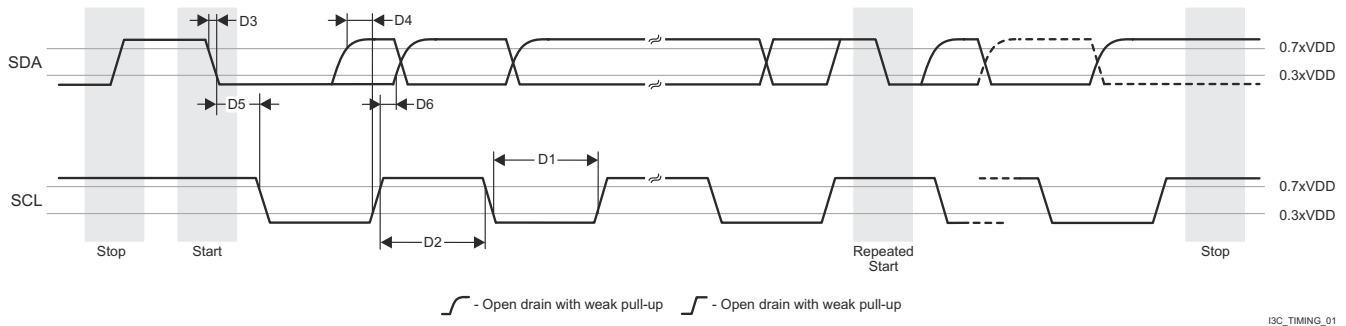

Figure 6-69. I3C Open Drain Timing

Table 6-44. I3C Push-Pull Timing Parameters for SDR and HDR-DDR Modes

NO.	PARAMETER	DESCRIPTION	MODE	MIN	MAX	UNIT
D1	f_{SCL}	SCL Clock Period	Controller	80	100000	ns
D2	t_{LOW}	SCL Clock Low Period	Controller	24		ns
	t_{DIG_L}			32		ns
D3	t_{HIGH_MIXED}	SCL Clock High Period of Mixed Bus (Mixed Bus Topology Not Supported)	Controller	24		ns
	$t_{DIG_H_MIXED}$			32	45	ns
D4	t_{HIGH}	SCL Clock High Period	Controller	24		ns
	t_{DIG_H}			32		ns
D5	t_{SCO}	Clock in to Data Out for Target	Target	12		ns
D6	t_{CR}	SCL Clock Rise Time	Controller	$150 \times 1 / f_{SCL}$	60	ns
D7	t_{CF}	SCL Clock Fall Time	Controller	$150 \times 1 / f_{SCL}$	60	ns
D8	t_{HD_PP}	SDA Signal Data Hold in Push Pull Mode	Controller	$t_{CR} + 3$ and $t_{CF} + 3$		ns
			Target	0		ns
D9	t_{SU_PP}	SDA Signal Data Setup In Push-Pull Mode	Controller, Target	3		ns
D10	t_{CASr}	Clock After Repeated START (Sr)	Controller	t_{CAS} MIN		ns
D11	t_{CBSr}	Clock Before Repeated START (Sr)	Controller	t_{CAS} MIN / 2		ns

- $f_{SCL} = 1 / (t_{DIG_L} + t_{DIG_H})$
- t_{DIG_L} and t_{DIG_H} are the clock Low and High periods as seen at the receiver end of the I3C Bus using V_{IL} and V_{IH} .
- When communicating with an I3C Device on a mixed Bus, the $t_{DIG_H_MIXED}$ period must be constrained to make sure that I2C Devices do not interpret I3C signaling as valid I2C signaling.
- As both edges are used, the hold time needs to be satisfied for the respective edges; $t_{CF} + 3$ for falling edge clocks, and $t_{CR} + 3$ for rising edge clocks.

5. Clock Frequency Minimum 0.01 MHz, Maximum 12.5 MHz

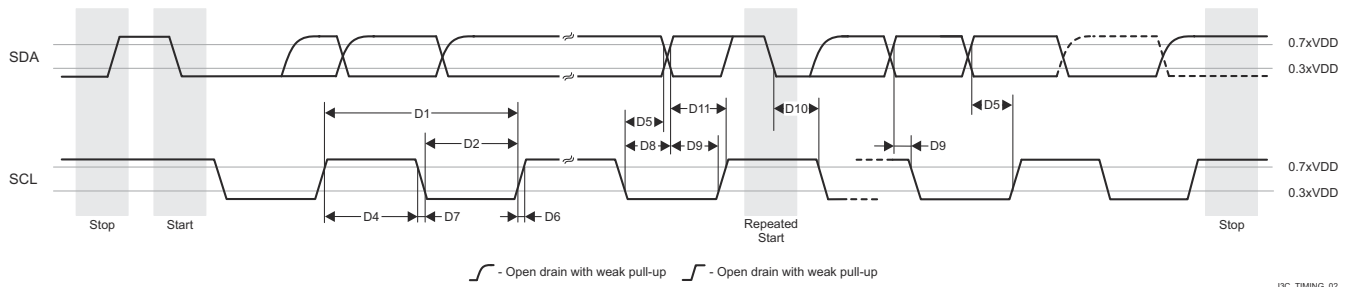

Figure 6-70. I3C Push-Pull Timing (SDR and HDR-DDR Modes)

6.10.5.14 MCAN

For more details about features and additional description information on the device Controller Area Network Interface, see the corresponding sections within [Signal Descriptions](#) and *Detailed Description*.

Note

The device has multiple MCAN modules. MCANn is a generic prefix applied to MCAN signal names, where n represents the specific MCAN module.

Table 6-45. MCAN Timing Conditions

PARAMETER		MIN	MAX	UNIT
INPUT CONDITIONS				
SR _i	Input slew rate	2	15	V/ns
OUTPUT CONDITIONS				
C _L	Output load capacitance	5	20	pF

Table 6-46. MCAN Switching Characteristics

NO.	PARAMETER		MIN	MAX	UNIT
MCAN1	t _{d(MCAN_TX)}	Delay time, transmit shift register to MCANn_TX pin ⁽¹⁾		10	ns
MCAN2	t _{d(MCAN_RX)}	Delay time, MCANn_RX pin to receive shift register ⁽¹⁾		10	ns

(1) n is [0:13] in MCANn_* or [0:1] in MCU_MCANn_*

For more information, see *Controller Area Network (MCAN)* section in *Peripherals* chapter in the device TRM.

6.10.5.15 MCASP

For more details about features and additional description information on the device Multichannel Audio Serial Port, see the corresponding sections within [Signal Descriptions](#) and [Detailed Description](#).

[Table 6-48](#) and [Figure 6-71](#) present timing requirements for MCASP0 to MCASP11.

[Table 6-47](#) represents MCASP timing conditions.

Table 6-47. MCASP Timing Conditions

PARAMETER		MIN	MAX	UNIT
INPUT CONDITIONS				
SR _I	Input slew rate	0.7	5	V/ns
OUTPUT CONDITIONS				
C _L	Output load capacitance	1	10	pF
PCB CONNECTIVITY REQUIREMENTS				
t _d (Trace Delay)	Propagation delay of each trace	100	1100	ps
t _d (Trace Mismatch Delay)	Propagation delay mismatch across all traces		100	ps

Table 6-48. MCASP Timing Requirements

NO.			MODE ⁽¹⁾	MIN	MAX	UNIT
ASP1	t _c (AHCLKRX)	Cycle time, MCASP[x]_AHCLKR/X		15.26		ns
ASP2	t _w (AHCLKRX)	Pulse duration, MCASP[x]_AHCLKR/X high or low		0.5P ⁽²⁾ - 1.53		ns
ASP3	t _c (ACLKRX)	Cycle time, MCASP[x]_ACLKR/X		15.26		ns
ASP4	t _w (ACLKRX)	Pulse duration, MCASP[x]_ACLKR/X high or low		0.5R ⁽³⁾ - 1.53		ns
ASP5	t _{su} (AFSRX-ACLKRX)	Setup time, MCASP[x]_AFSR/X input valid before MCASP[x]_ACLKR/X	ACLKR/X int	12.3		ns
			ACLKR/X ext in/out	4		
ASP6	t _h (ACLKRX-AFSRX)	Hold time, MCASP[x]_AFSR/X input valid after MCASP[x]_ACLKR/X	ACLKR/X int	-1		ns
			ACLKR/X ext in/out	1.6		
ASP7	t _{su} (AXR-ACLKRX)	Setup time, MCASP[x]_AXR input valid before MCASP[x]_ACLKR/X	ACLKR/X int	12.3		ns
			ACLKR/X ext in/out	4		
ASP8	t _h (ACLKRX-AXR)	Hold time, MCASP[x]_AXR input valid after MCASP[x]_ACLKR/X	ACLKR/X int	-1		ns
			ACLKR/X ext in/out	1.6		

- (1) ACLKR internal: ACLKRCTL.CLKRM=1, PDIR.ACLKR = 1
 ACLKR external input: ACLKRCTL.CLKRM=0, PDIR.ACLKR=0
 ACLKR external output: ACLKRCTL.CLKRM=0, PDIR.ACLKR=1
 ACLKX internal: ACLKXCTL.CLKXM=1, PDIR.ACLKX = 1
 ACLKX external input: ACLKXCTL.CLKXM=0, PDIR.ACLKX=0
 ACLKX external output: ACLKXCTL.CLKXM=0, PDIR.ACLKX=1
- (2) P = AHCLKR/X period in ns.
 (3) R = ACLKR/X period in ns.

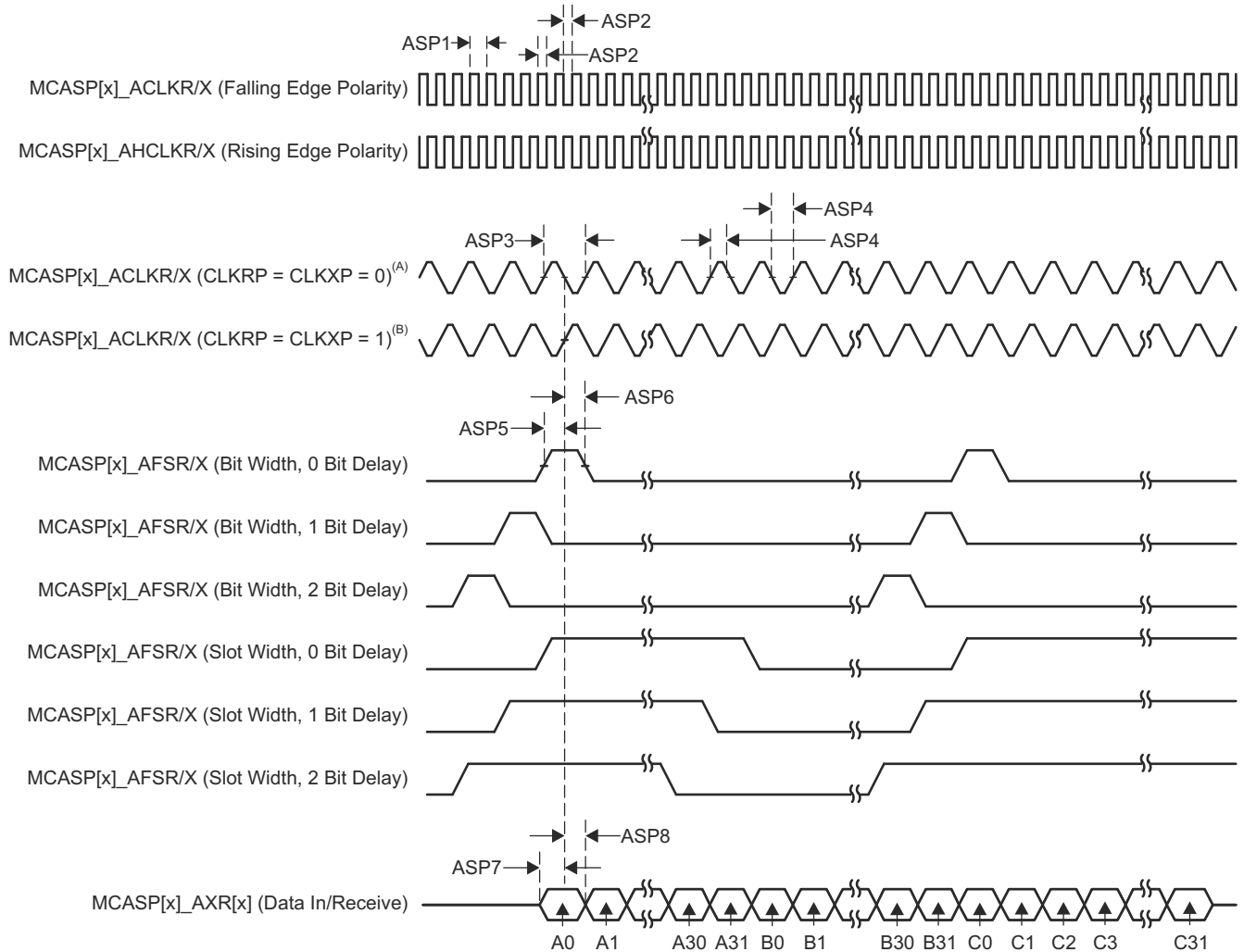

- A. For CLKRP = CLKXP = 0, the MCASP transmitter is configured for rising edge (to shift data out) and the MCASP receiver is configured for falling edge (to shift data in).
- B. For CLKRP = CLKXP = 1, the MCASP transmitter is configured for falling edge (to shift data out) and the MCASP receiver is configured for rising edge (to shift data in).

Figure 6-71. MCASP Input Timing

Table 6-49 and Figure 6-72 present switching characteristics over recommended operating conditions for MCASP0 to MCASP11.

Table 6-49. MCASP Switching Characteristics

NO.	PARAMETER	DESCRIPTION	MODE ⁽¹⁾	MIN	MAX	UNIT
ASP9	$t_{c(AHCLKRX)}$	Cycle time, MCASP[x]_AHCLKR/X		20		ns
ASP10	$t_{w(AHCLKRX)}$	Pulse duration, MCASP[x]_AHCLKR/X high or low		0.5P ⁽²⁾ - 2		ns
ASP11	$t_{c(ACLKRX)}$	Cycle time, MCASP[x]_ACLKR/X		20		ns
ASP12	$t_{w(ACLKRX)}$	Pulse duration, MCASP[x]_ACLKR/X high or low		0.5R ⁽³⁾ - 2		ns
ASP13	$t_{d(ACLKRX-AFSRX)}$	Delay time, MCASP[x]_ACLKR/X transmit edge to MCASP[x]_AFSR/X output valid	ACLKR/X int	0	7.25	ns
			ACLKR/X ext in/out	-15.28	12.84	
ASP14	$t_{d(ACLKX-AXR)}$	Delay time, MCASP[x]_ACLKX transmit edge to MCASP[x]_AXR output valid	ACLKR/X int	0	7.25	ns
			ACLKR/X ext in/out	-15.28	12.84	
ASP15	$t_{dis(ACLKX-AXR)}$	Disable time, MCASP[x]_ACLKX transmit edge to MCASP[x]_AXR output high impedance	ACLKR/X int	0	7.25	ns
			ACLKR/X ext in/out	-14.9	14	

- (1) ACLKR internal: ACLKRCTL.CLKRM=1, PDIR.ACLKR = 1
 ACLKR external input: ACLKRCTL.CLKRM=0, PDIR.ACLKR=0
 ACLKR external output: ACLKRCTL.CLKRM=0, PDIR.ACLKR=1
 ACLKX internal: ACLKXCTL.CLKXM=1, PDIR.ACLKX = 1
 ACLKX external input: ACLKXCTL.CLKXM=0, PDIR.ACLKX=0
 ACLKX external output: ACLKXCTL.CLKXM=0, PDIR.ACLKX=1
- (2) P = AHCLKR/X period in ns.
- (3) R = ACLKR/X period in ns.

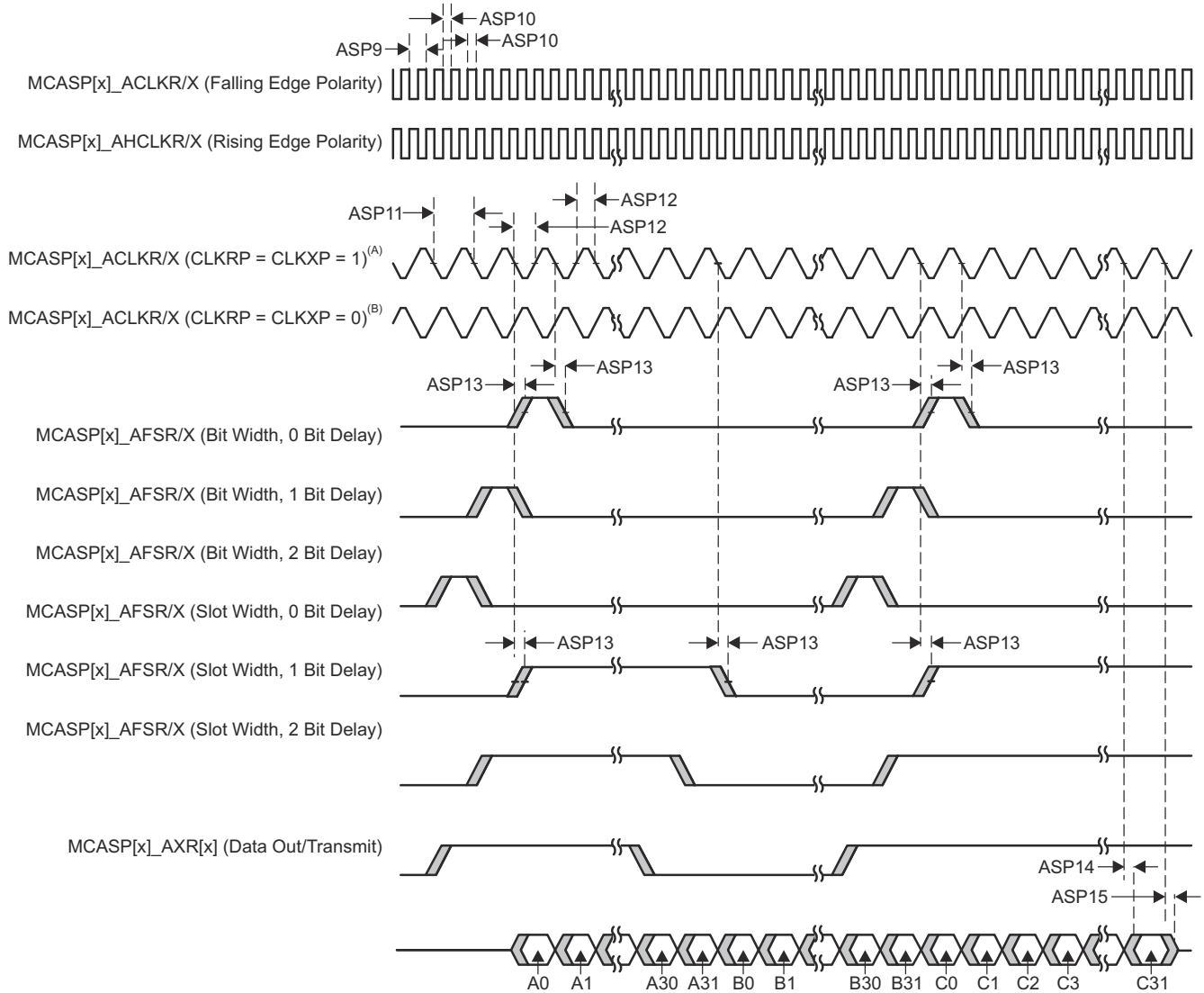

- A. For CLKRP = CLKXP = 1, the MCASP transmitter is configured for falling edge (to shift data out) and the MCASP receiver is configured for rising edge (to shift data in).
- B. For CLKRP = CLKXP = 0, the MCASP transmitter is configured for rising edge (to shift data out) and the MCASP receiver is configured for falling edge (to shift data in).

Figure 6-72. MCASP Output Timing

For more information, see *Multichannel Audio Serial Port (MCASP)* section in *Peripherals* chapter in the device TRM.

6.10.5.16 MCSPI

For more details about features and additional description information on the device Serial Port Interface, see the corresponding sections within [Signal Descriptions](#) and *Detailed Description*.

For more information, see *Multichannel Serial Peripheral Interface (MCSPI)* section in *Peripherals* chapter in the device TRM.

[Table 6-50](#) represents MCSPI timing conditions.

Note

The IO timings provided in this section are applicable for all combinations of signals for MCU_SPI0 and MCU_SPI1. However, the timings are only valid for MCU_SPI0 and MCU_SPI1 if signals within a single IOSET are used. The IOSETs are defined in the [Table 6-55](#) and [Table 6-56](#) tables.

Table 6-50. MCSPI Timing Conditions

PARAMETER		MIN	MAX	UNIT	
INPUT CONDITIONS					
SR _I	Input slew rate	2	8.5	V/ns	
OUTPUT CONDITIONS					
C _L	Output load capacitance	CLK	6	24	pF
		D[x], CSi	6	12	pF

6.10.5.16.1 MCSPI — Controller Mode

[Table 6-51](#), [Figure 6-73](#), [Table 6-52](#), and [Figure 6-74](#) present timing requirements and switching characteristics for MCSPI – Controller Mode.

Table 6-51. MCSPI Timing Requirements - Controller Mode

see [Figure 6-73](#)

NO.		MIN	MAX	UNIT
SM4	t _{su(misoV-spicklV)} Setup time, SPI_D[x] valid before SPI_CLK active edge	2.9		ns
SM5	t _{h(spicklV-misoV)} Hold time, SPI_D[x] valid after SPI_CLK active edge	2		ns

Table 6-52. MCSPI Switching Characteristics - Controller Mode

see [Figure 6-74](#)

NO.	PARAMETER	MODE	MIN	MAX	UNIT
SM1	t _{c(spickl)} Cycle time, SPI_CLK		20.8		ns
SM2	t _{w(spicklL)} Pulse duration, SPI_CLK low		0.5P - 1 ⁽¹⁾		ns
SM3	t _{w(spicklH)} Pulse duration, SPI_CLK high		0.5P - 1 ⁽¹⁾		ns
SM6	t _{d(spicklV-simoV)} Delay time, SPI_CLK active edge to SPI_D[x] transition		-2	2	ns
SM7	t _{d(csV-simoV)} Delay time, SPI_CSi active edge to SPI_D[x] transition		5		ns
SM8	t _{d(csV-spickl)} Delay time, SPI_CSi active to SPI_CLK first edge	PHA = 0 ⁽²⁾	B - 4 ⁽³⁾		ns
		PHA = 1 ⁽²⁾	A - 4 ⁽⁴⁾		ns
SM9	t _{d(spicklV-csV)} Delay time, SPI_CLK last edge to SPI_CSi inactive	PHA = 0 ⁽²⁾	A - 4 ⁽⁴⁾		ns
		PHA = 1 ⁽²⁾	B - 4 ⁽³⁾		ns

(1) P = SPI_CLK period in ns

(2) SPI_CLK phase is programmable with the PHA bit of the MCSPI_CHCONF_0/1/2/3 register

(3) B = (TCS + .5) * TSPICKLREF, where TCSns a bit field of the MCSPI_CHCONF_0/1/2/3 register and Fratio = Even >= 2.

(4) When P = 20.8 ns, A = (TCS + 1) * TSPICKLREF, where TCSns a bit field of the MCSPI_CHCONF_0/1/2/3 register.

When $P > 20.8 \text{ ns}$, $A = (TCS + 0.5) * Fratio * TSPICKREF$, where TCSns a bit field of the MCSPI_CHCONF_0/1/2/3 register.

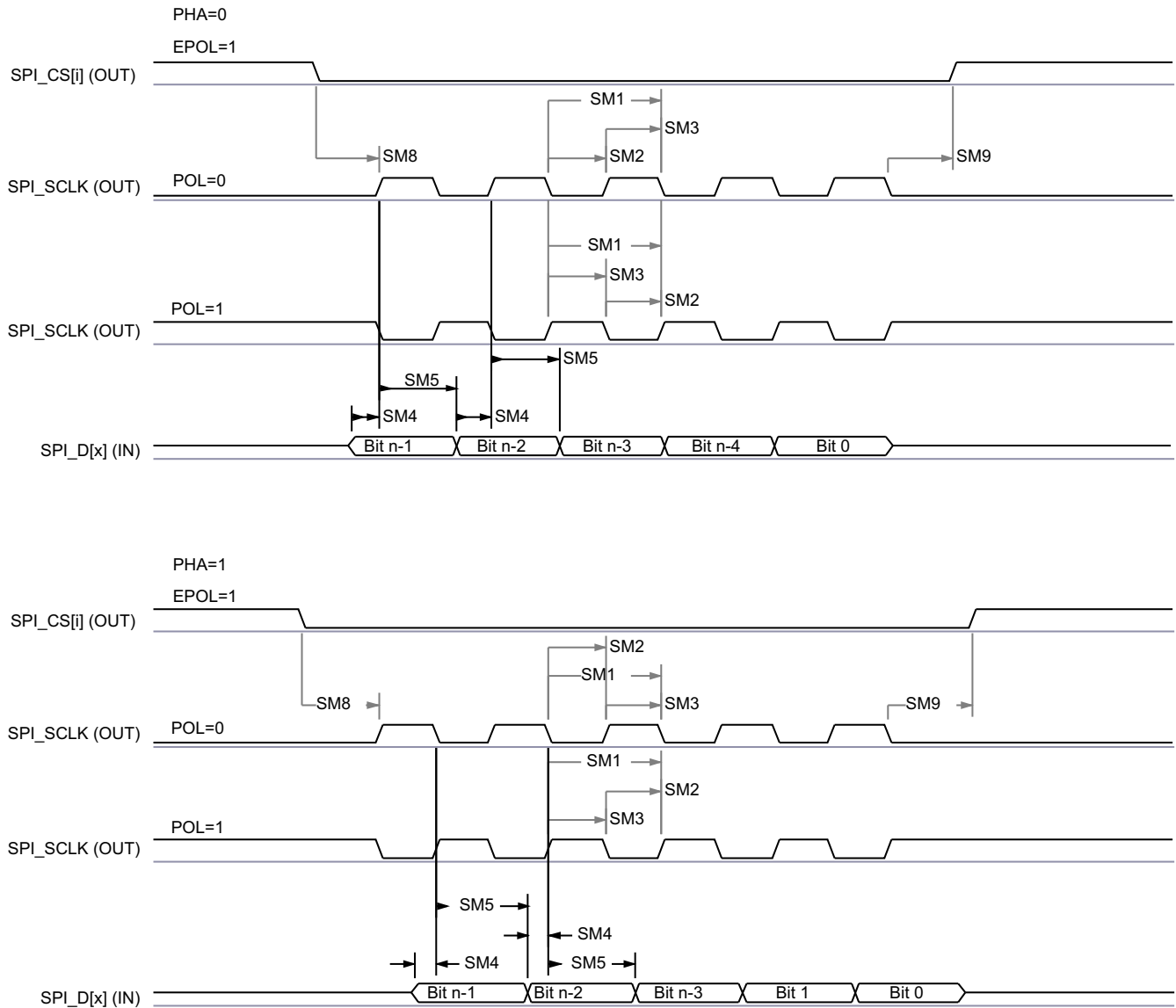

SPRSP92C_TIMING_MCSPI_02

Figure 6-73. SPI Controller Mode Receive Timing

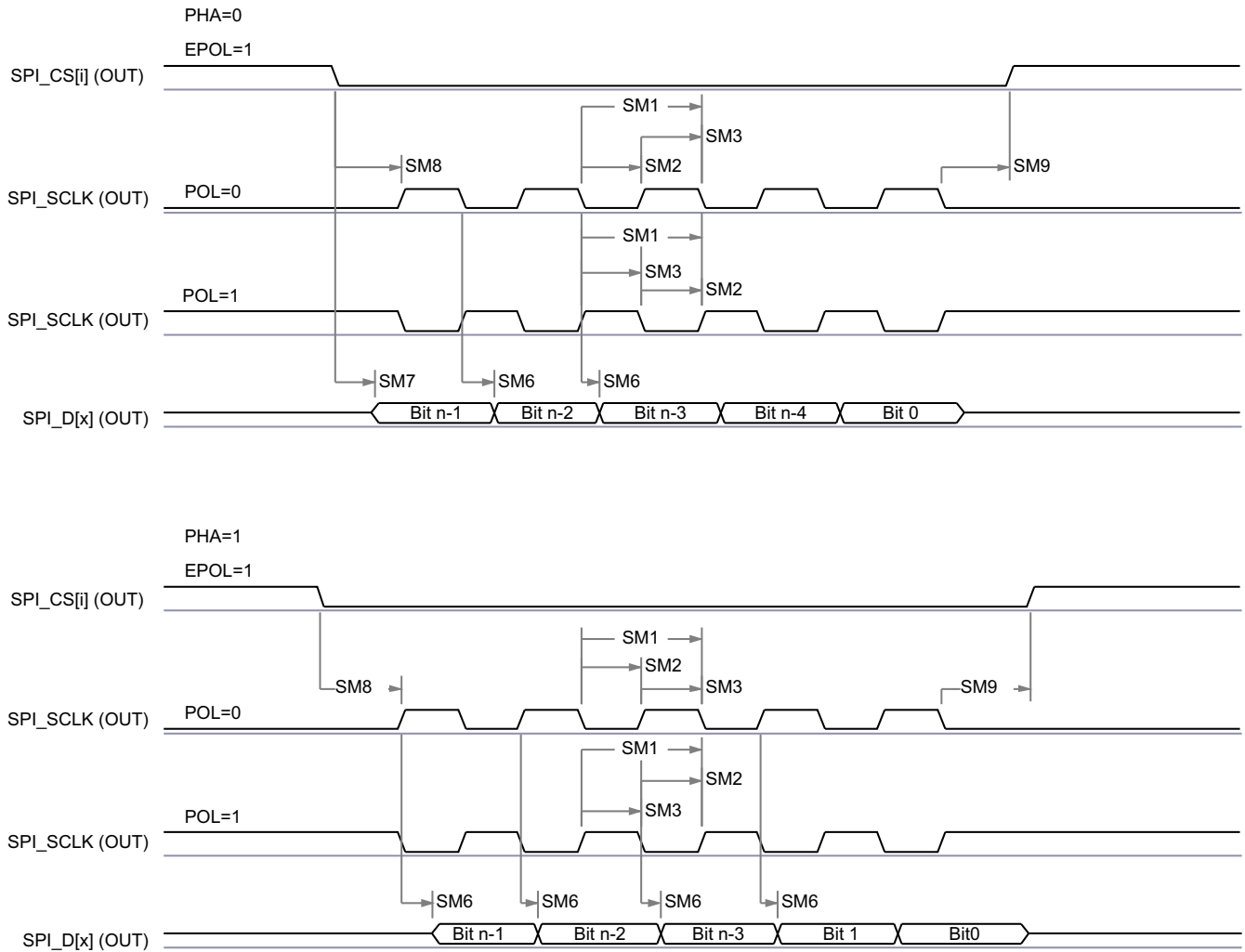

SPRSP08_TIMING_McSPI_01

Figure 6-74. MCSPI Controller Mode Transmit Timing

6.10.5.16.2 MCSPI — Peripheral Mode

Table 6-53, Table 6-54, Figure 6-75, and Figure 6-76 present timing requirements and switching characteristics for MCSPI – Peripheral Mode.

Table 6-53. MCSPI Timing Requirements - Peripheral Mode

NO.	PARAMETER	DESCRIPTION	MODE	MIN	MAX	UNIT
SS1	$t_{c(spclk)}$	Cycle time, SPI_CLK		20.8		ns
SS2	$t_{w(spclkL)}$	Pulse duration, SPI_CLK low		0.45P ⁽¹⁾		ns
SS3	$t_{w(spclkH)}$	Pulse duration, SPI_CLK high		0.45P ⁽¹⁾		ns
SS4	$t_{su(simoV-spclkV)}$	Setup time, SPI_D[x] valid before SPI_CLK active edge		5		ns
SS5	$t_{h(spclkV-simoV)}$	Hold time, SPI_D[x] valid after SPI_CLK active edge		5		ns
SS8	$t_{su(csV-spclkV)}$	Setup time, SPI_CSi valid before SPI_CLK first edge		5		ns
SS9	$t_{h(spclkV-csV)}$	Hold time, SPI_CSi valid after SPI_CLK last edge		5		ns

Table 6-54. MCSPI Switching Characteristics - Peripheral Mode

NO.	PARAMETER	DESCRIPTION	MIN	MAX	UNIT
SS6	$t_{d(spiclkV-somiv)}$	Delay time, SPI_CLK active edge to SPI_D[x] transition	2	17.12	ns
SS7	$t_{sk(csV-somiv)}$	Delay time, SPI_CSi active edge to SPI_D[x] transition	20.95		ns

(1) P = SPI_CLK period in ns.

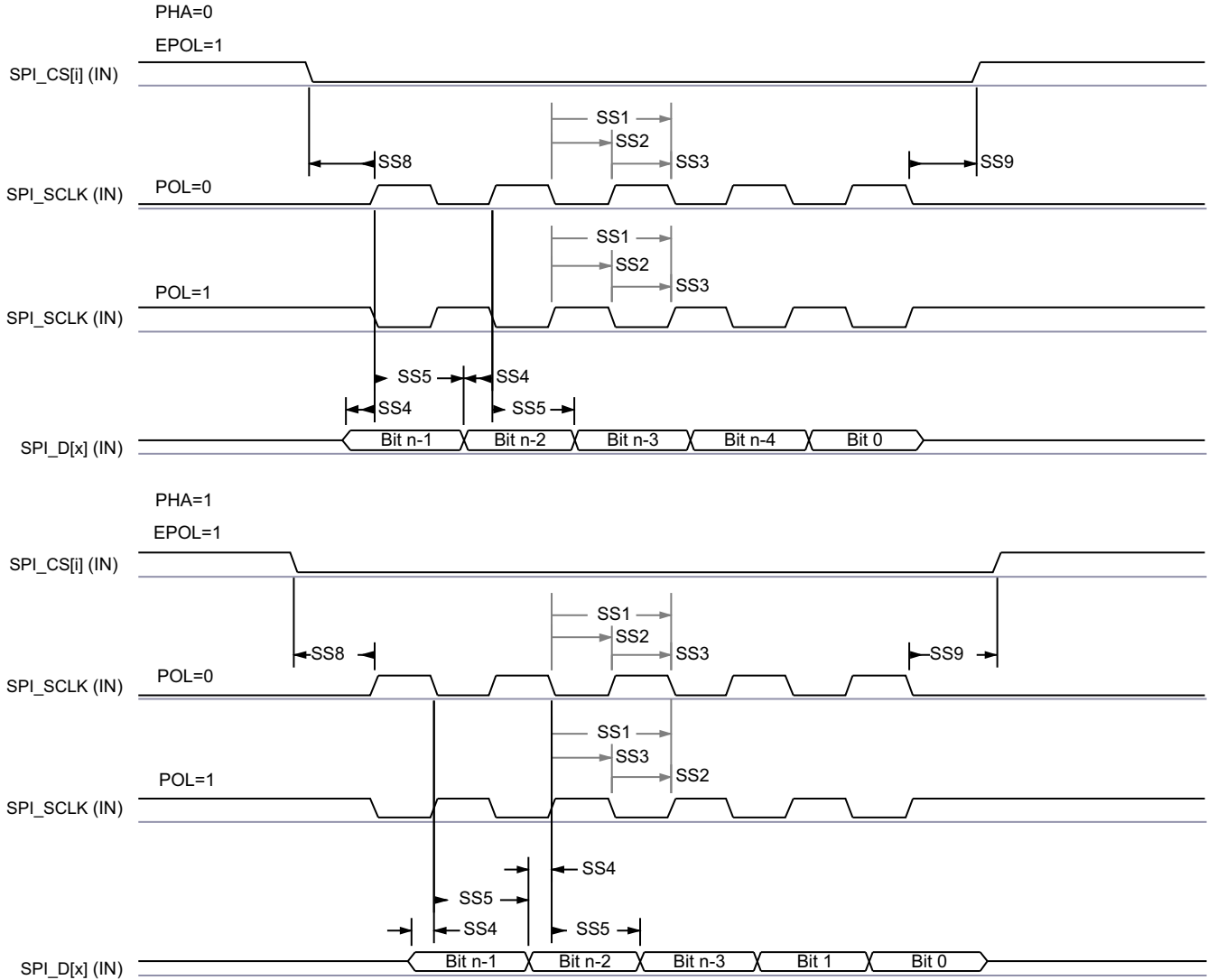

SPRSP08_TIMING_McSPI_04

Figure 6-75. SPI Peripheral Mode Receive Timing

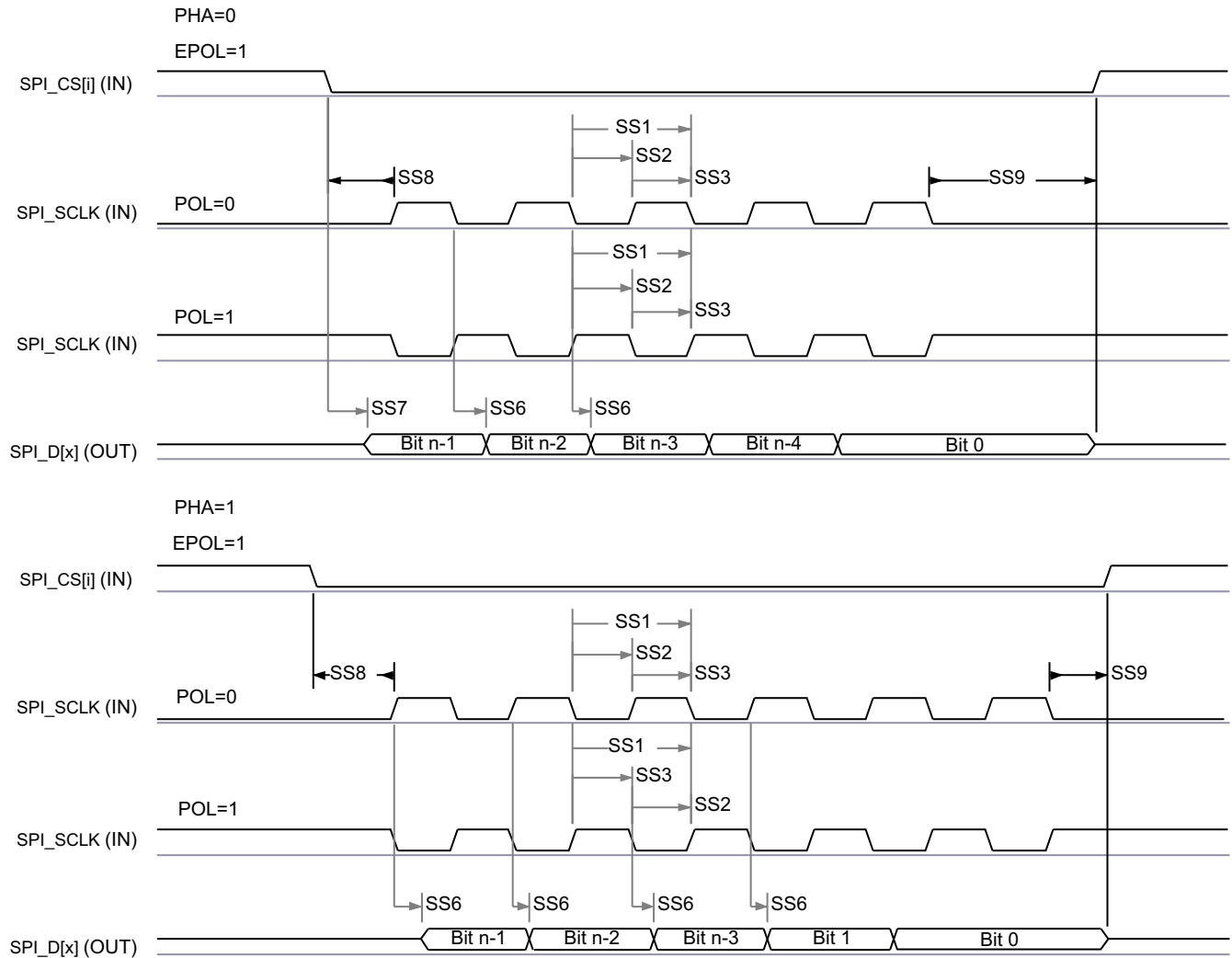

SPRSP08_TIMING_McSPI_03

Figure 6-76. MCSPI Peripheral Mode Transmit Timing

Table 6-55 and Table 6-56 present the specific groupings of signals (IOSET) for use with MCU_SPI0 and MCU_SPI1.

Table 6-55. MCU_SPI0 IOSETs

Signals	IOSET1		IOSET2	
	BALL NAME	MUX	BALL NAME	MUX
MCU_SPI0_CLK	MCU_SPI0_CLK	0	MCU_SPI0_CLK	0
MCU_SPI0_D0	MCU_SPI0_D0	0	MCU_SPI0_D0	0
MCU_SPI0_D1	MCU_SPI0_D1	0	MCU_SPI0_D1	0
MCU_SPI0_CS0	MCU_SPI0_CS0	0	MCU_SPI0_CS0	0
MCU_SPI0_CS1	MCU_OSPI1_D3	5	WKUP_GPIO0_12	1
MCU_SPI0_CS2	MCU_OSPI1_CSn1	5	WKUP_GPIO0_14	1

Table 6-56. MCU_SPI1 IOSET

Signals	IOSET1		IOSET2	
	BALL NAME	MUX	BALL NAME	MUX
MCU_SPI1_CLK	MCU_SPI1_CLK	0	MCU_SPI1_CLK	0
MCU_SPI1_D0	MCU_SPI1_D0	0	MCU_SPI1_D0	0
MCU_SPI1_D1	MCU_SPI1_D1	0	MCU_SPI1_D1	0
MCU_SPI1_CS0	MCU_SPI1_CS0	0	MCU_SPI1_CS0	0
MCU_SPI1_CS1	MCU_OSPI1_D1	5	WKUP_GPIO0_13	1
MCU_SPI1_CS2	MCU_OSPI1_D2	5	WKUP_GPIO0_15	1

For more information, see *Multichannel Serial Peripheral Interface (MCSPi)* section in *Peripherals* chapter in the device TRM.

6.10.5.17 MMCS D

The MMCS D Host Controller provides an interface to embedded Multi-Media Card (MMC), Secure Digital (SD), and Secure Digital IO (SDIO) devices. The MMCS D Host Controller deals with MMC/SD/SDIO protocol at transmission level, data packing, adding cyclic redundancy checks (CRCs), start/end bit insertion, and checking for syntactical correctness.

For more details about MMCS D interfaces, see the corresponding MMC0, MMC1, and MMC2 sections within [Signal Descriptions](#) and *Detailed Description*.

Note

Some operating modes require software configuration of the MMC DLL delay settings, as shown in [Table 6-57](#) and [Table 6-67](#).

For more information, see *Multi-Media Card/Secure Digital (MMCS D) Interface* section in *Peripherals* chapter in the device TRM.

6.10.5.17.1 MMC0 - eMMC Interface

MMC0 interface is compliant with the JEDEC eMMC electrical standard v5.1 (JESD84-B51) and it supports the following eMMC applications:

- Legacy speed
- High speed SDR
- High speed DDR
- High Speed HS200
- High Speed HS400

[Table 6-57](#) presents the required DLL software configuration settings for MMC0 timing modes.

Table 6-57. MMC0 DLL Delay Mapping for All Timing Modes

REGISTER NAME		MMCS D0_SS_PHY_CTRL_4_REG					MMCS D0_SS_PHY_CTRL_5_REG		
BIT FIELD		[31:24]	[20]	[15:12]	[8]	[4:0]	[17:16]	[10:8]	[2:0]
BIT FIELD NAME		STRBSEL	OTAPDLYENA	OTAPDLYSEL	ITAPDLYENA	ITAPDLYSEL	SELDLYTXCLK SELDLYRXCLK	FRQSEL	CLKBUFSEL
MODE	DESCRIPTION	STROBE DELAY	OUTPUT DELAY ENABLE	OUTPUT DELAY VALUE	INPUT DELAY ENABLE	INPUT DELAY VALUE	DLL/ DELAY CHAIN SELECT	DLL REF FREQUENCY	DELAY BUFFER DURATION
Legacy SDR	8-bit PHY operating 1.8 V, 25 MHz	0x0	0x0	NA	0x1	0x10	0x1	0x0	0x7
High Speed SDR	8-bit PHY operating 1.8 V, 50 MHz	0x0	0x0	NA	0x1	0xA	0x1	0x0	0x7

Table 6-57. MMC0 DLL Delay Mapping for All Timing Modes (continued)

REGISTER NAME		MMCS0_SS_PHY_CTRL_4_REG					MMCS0_SS_PHY_CTRL_5_REG		
BIT FIELD		[31:24]	[20]	[15:12]	[8]	[4:0]	[17:16]	[10:8]	[2:0]
BIT FIELD NAME		STRBSEL	OTAPDLYENA	OTAPDLYSEL	ITAPDLYENA	ITAPDLYSEL	SELDLYTXCLK SELDLYRXCLK	FRQSEL	CLKBUFSEL
MODE	DESCRIPTION	STROBE DELAY	OUTPUT DELAY ENABLE	OUTPUT DELAY VALUE	INPUT DELAY ENABLE	INPUT DELAY VALUE	DLL/ DELAY CHAIN SELECT	DLL REF FREQUENCY	DELAY BUFFER DURATION
High Speed DDR	8-bit PHY operating 1.8 V, 50 MHz	0x0	0x1	0x6	0x1	Tuning	0x0	0x4	0x7
HS200	8-bit PHY operating 1.8 V, 200 MHz	0x0	0x1	0x8	0x1	Tuning	0x0	0x0	0x7
HS400	8-bit PHY operating 1.8 V, 200 MHz	0x66	0x1	0x5	0x1	Tuning	0x0	0x0	0x7

Table 6-58 presents timing conditions for MMC0.

Table 6-58. MMC0 Timing Conditions

PARAMETER		MIN	MAX	UNIT	
INPUT CONDITIONS					
SR _i	Input slew rate	Legacy SDR	0.14	1.44	V/ns
		High Speed SDR	0.3	0.90	V/ns
		High Speed DDR (CMD)	0.3	0.90	V/ns
		High Speed DDR (DAT[7:0])	0.45	0.90	V/ns
OUTPUT CONDITIONS					
C _L	Output load capacitance	HS200, HS400	1	6	pF
		All other modes	1	12	pF
PCB CONNECTIVITY REQUIREMENTS					
t _d (Trace Delay)	Propagation delay of each trace	All modes	134	756	ps
t _d (Trace Mismatch Delay)	Propagation delay mismatch across all traces	Legacy SDR, High Speed SDR, High Speed DDR		100	ps
		HS200, HS400		8	ps

6.10.5.17.1.1 Legacy SDR Mode

Table 6-59, Figure 6-77, Table 6-60, and Figure 6-78 present timing requirements and switching characteristics for MMC0 – Legacy SDR Mode.

Table 6-59. MMC0 Timing Requirements – Legacy SDR Mode

see Figure 6-77

NO.			MIN	MAX	UNIT
LSDR1	$t_{su(cmdV-clkH)}$	Setup time, MMC0_CMD valid before MMC0_CLK rising edge	2.5		ns
LSDR2	$t_h(clkH-cmdV)$	Hold time, MMC0_CMD valid after MMC0_CLK rising edge	6.5		ns
LSDR3	$t_{su(dV-clkH)}$	Setup time, MMC0_DAT[7:0] valid before MMC0_CLK rising edge	2.5		ns
LSDR4	$t_h(clkH-dV)$	Hold time, MMC0_DAT[7:0] valid after MMC0_CLK rising edge	6.5		ns

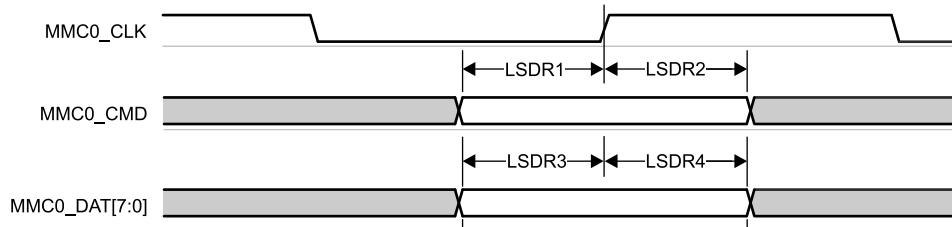

Figure 6-77. MMC0 – Legacy SDR – Receive Mode

Table 6-60. MMC0 Switching Characteristics – Legacy SDR Mode

see Figure 6-78

NO.	PARAMETER	MIN	MAX	UNIT
	$f_{op(clk)}$		25	MHz
LSDR5	$t_c(clk)$	40		ns
LSDR6	$t_w(clkH)$	18.7		ns
LSDR7	$t_w(clkL)$	18.7		ns
LSDR8	$t_d(clkL-cmdV)$	-3.2	3.8	ns
LSDR9	$t_d(clkL-dV)$	-3.2	3.8	ns

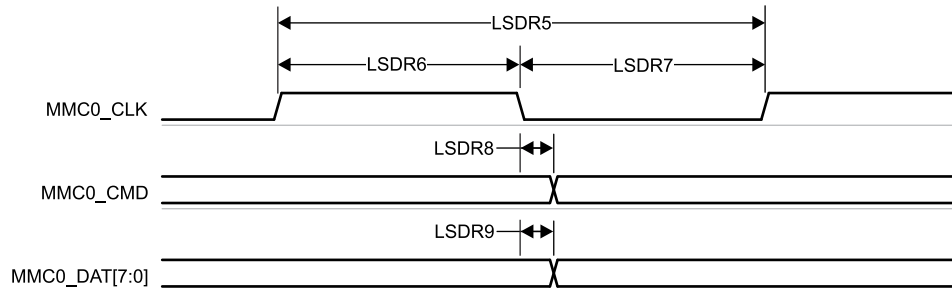

Figure 6-78. MMC0 – Legacy SDR – Transmit Mode

6.10.5.17.1.2 High Speed SDR Mode

Table 6-61, Figure 6-79, Table 6-62, and Figure 6-80 present timing requirements and switching characteristics for MMC0 – High Speed SDR Mode.

Table 6-61. MMC0 Timing Requirements – High Speed SDR Mode

see Figure 6-79

NO.			MIN	MAX	UNIT
HSSDR1	$t_{su(cmdV-clkH)}$	Setup time, MMC0_CMD valid before MMC0_CLK rising edge	2.99		ns
HSSDR2	$t_{h(clkH-cmdV)}$	Hold time, MMC0_CMD valid after MMC0_CLK rising edge	2.67		ns
HSSDR3	$t_{su(dV-clkH)}$	Setup time, MMC0_DAT[7:0] valid before MMC0_CLK rising edge	2.99		ns
HSSDR4	$t_{h(clkH-dV)}$	Hold time, MMC0_DAT[7:0] valid after MMC0_CLK rising edge	2.67		ns

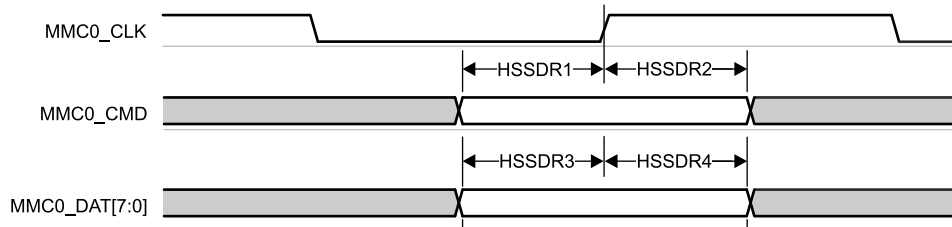

Figure 6-79. MMC0 – High Speed SDR Mode – Receive Mode

Table 6-62. MMC0 Switching Characteristics – High Speed SDR Mode

see Figure 6-80

NO.	PARAMETER	MIN	MAX	UNIT
	$f_{op(clk)}$		50	MHz
HSSDR5	$t_c(clk)$	20		ns
HSSDR6	$t_w(clkH)$	9.2		ns
HSSDR7	$t_w(clkL)$	9.2		ns
HSSDR8	$t_d(clkL-cmdV)$	-3.2	3.8	ns
HSSDR9	$t_d(clkL-dV)$	-3.2	3.8	ns

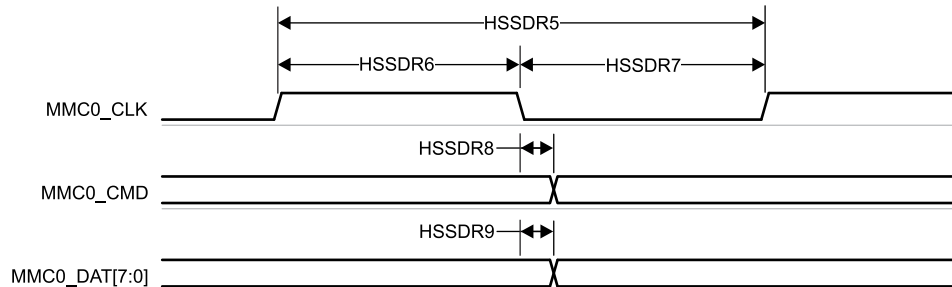

Figure 6-80. MMC0 – High Speed SDR Mode – Transmit Mode

6.10.5.17.1.3 High Speed DDR Mode

Table 6-63, Figure 6-81, Table 6-64, and Figure 6-82 present timing requirements and switching characteristics for MMC0 – High Speed DDR Mode.

Table 6-63. MMC0 Timing Requirements – High Speed DDR Mode

see Figure 6-81

NO.			MIN	MAX	UNIT
HSDDR1	$t_{su(cmdV-clkH)}$	Setup time, MMC0_CMD valid before MMC0_CLK rising edge	3.79		ns
HSDDR2	$t_{h(clkH-cmdV)}$	Hold time, MMC0_CMD valid after MMC0_CLK rising edge	2.67		ns
HSDDR3	$t_{su(dV-clkV)}$	Setup time, MMC0_DAT[7:0] valid before MMC0_CLK transition	0.74		ns
HSDDR4	$t_{h(clkV-dV)}$	Hold time, MMC0_DAT[7:0] valid after MMC0_CLK transition	1.67		ns

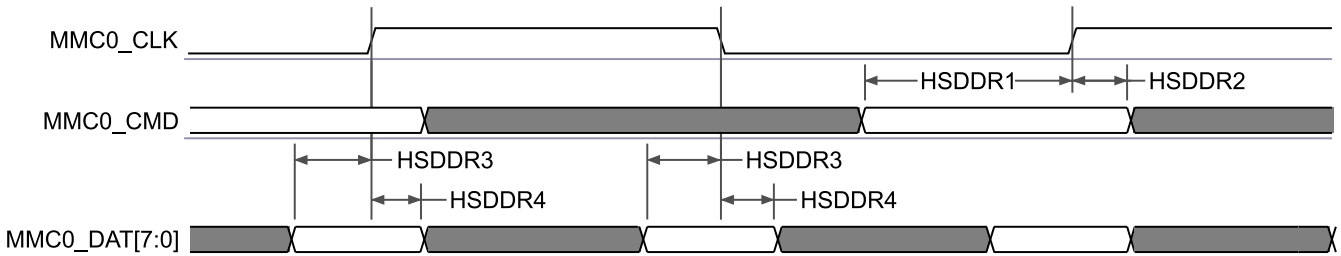

Figure 6-81. MMC0 – High Speed DDR Mode – Receive Mode

Table 6-64. MMC0 Switching Characteristics – High Speed DDR Mode

see Figure 6-82

NO.	PARAMETER	MIN	MAX	UNIT
	$f_{op(clk)}$		50	MHz
HSDDR5	$t_{c(clk)}$	20		ns
HSDDR6	$t_{w(clkH)}$	9.2		ns
HSDDR7	$t_{w(clkL)}$	9.2		ns
HSDDR8	$t_{d(clkH-cmdV)}$	3.4	9.8	ns
HSDDR9	$t_{d(clkV-dV)}$	2.9	6.85	ns

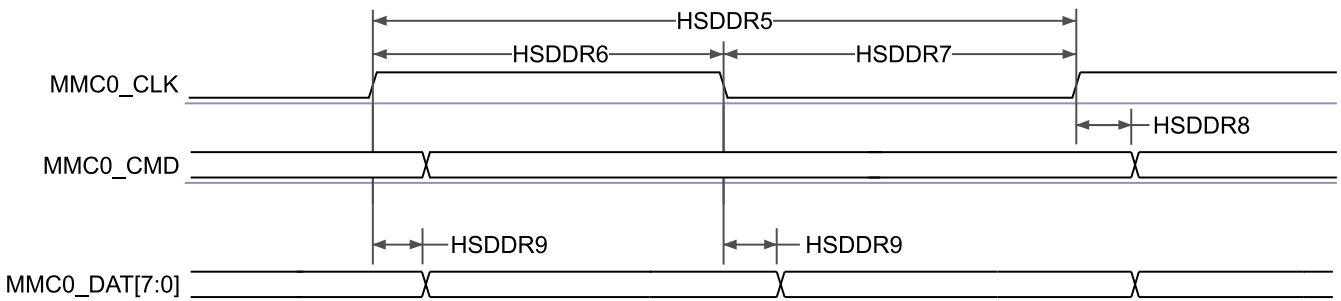

Figure 6-82. MMC0 – High Speed DDR Mode – Transmit Mode

6.10.5.17.1.4 HS200 Mode

Table 6-65 and Figure 6-83 present switching characteristics for MMC0 – HS200 Mode.

Table 6-65. MMC0 Switching Characteristics – HS200 Mode

see Figure 6-83

NO.	PARAMETER	MIN	MAX	UNIT
	$f_{op}(clk)$		200	MHz
HS2005	$t_{c}(clk)$	5		ns
HS2006	$t_{w}(clkH)$	2.08		ns
HS2007	$t_{w}(clkL)$	2.08		ns
HS2008	$t_{d}(clkL-cmdV)$	0.99	3.16	ns
HS2009	$t_{d}(clkL-dV)$	0.99	3.16	ns

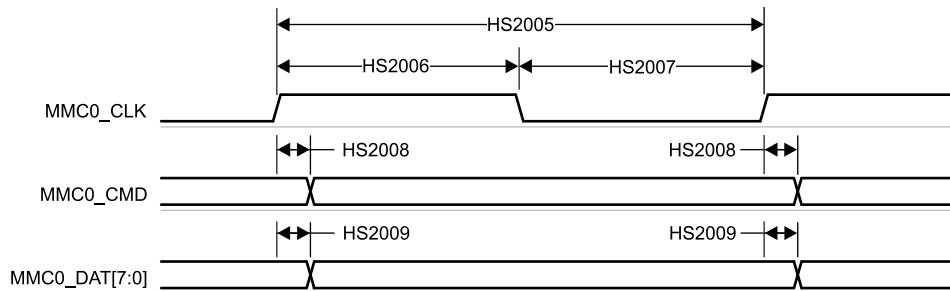

Figure 6-83. MMC0 – HS200 Mode – Transmit Mode

6.10.5.17.1.5 HS400 Mode

Table 6-66 and Figure 6-84 present switching characteristics for MMC0 – HS400 Mode.

Table 6-66. MMC0 Switching Characteristics – HS400 Mode

see Figure 6-84

NO.	PARAMETER	DESCRIPTION	MIN	MAX	UNIT
	$f_{op}(clk)$	Operating frequency, MMC0_CLK		200	MHz
HS4005	$t_{c}(clk)$	Cycle time, MMC0_CLK	5		ns
HS4006	$t_{w}(clkH)$	Pulse duration, MMC0_CLK high	2.08		ns
HS4007	$t_{w}(clkL)$	Pulse duration, MMC0_CLK low	2.08		ns
HS4008	$t_{d}(clkH-cmdV)$	Delay time, MMC0_CLK rising clock edge to MMC0_CMD transition	0.99	3.28	ns
HS4009	$t_{d}(clkV-dV)$	Delay time, MMC0_CLK transition to MMC0_DAT[7:0] transition	0.59	1.84	ns

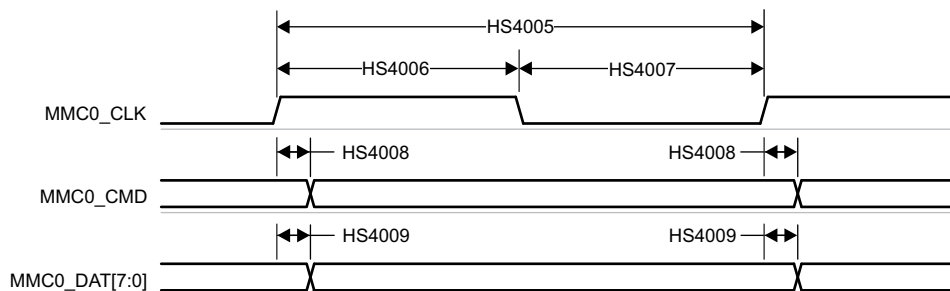

Figure 6-84. eMMC in – HS400 Mode – Transmitter Mode

6.10.5.17.2 MMC1/2 - SD/SDIO Interface

MMC1 interface is compliant with the SD Host Controller Standard Specification 4.10 and SD Physical Layer Specification v3.01 as well as SDIO Specification v3.00 and they support the following SD Card applications:

- Default speed
- High speed
- UHS-I SDR12
- UHS-I SDR25
- UHS-I SDR50
- UHS-I SDR104
- UHS-I DDR50

Table 6-67 presents the required DLL software configuration settings for MMC1 timing modes.

Table 6-67. MMC1 DLL Delay Mapping for All Timing Modes

REGISTER NAME		MMCSD12_SS_PHY_CTRL_4_REG				MMCSD12_SS_PHY_CTRL_5_REG
BIT FIELD		[20]	[15:12]	[8]	[4:0]	[2:0]
BIT FIELD NAME		OTAPDLYENA	OTAPDLYSEL	ITAPDLYENA	ITAPDLYSEL	CLKBUFSEL
MODE	DESCRIPTION	DELAY ENABLE	DELAY VALUE	INPUT DELAY ENABLE	INPUT DELAY VALUE	DELAY BUFFER DURATION
Default Speed	4-bit PHY operating 3.3 V, 25 MHz	0x0	0x0	0x0	0x0	0x7
High Speed	4-bit PHY operating 3.3 V, 50 MHz	0x0	0x0	0x0	0x0	0x7
UHS-I SDR12	4-bit PHY operating 1.8 V, 25 MHz	0x1	0xF	0x0	0x0	0x7
UHS-I SDR25	4-bit PHY operating 1.8 V, 50 MHz	0x1	0xF	0x0	0x0	0x7
UHS-I SDR50	4-bit PHY operating 1.8 V, 100 MHz	0x1	0xC	0x1	Tuning	0x7
UHS-I DR50	4-bit PHY operating 1.8 V, 50 MHz	0x1	0xC	0x1	0x2	0x7
UHS-I SDR104	4-bit PHY operating 1.8, V 200 MHz	0x1	0x5	0x1	Tuning	0x7

Table 6-68 presents timing conditions for MMC1.

Table 6-68. MMC1 Timing Conditions

PARAMETER		MIN	MAX	UNIT	
INPUT CONDITIONS					
SR _i	Input slew rate	Default Speed, High Speed	0.69	2.06	V/ns
		UHS-I SDR12, UHS-I SDR25	0.34	1.34	V/ns
		USH-1 DDR50	1.00	2.00	V/ns
OUTPUT CONDITIONS					
C _L	Output load capacitance	All modes	1	10	pF
PCB CONNECTIVITY REQUIREMENTS					
t _d (Trace Delay)	Propagation delay of each trace	UHS-I DDR50	240.03	1134	ps
		All other modes	126	1386	ps
t _d (Trace Mismatch Delay)	Propagation delay mismatch across all traces	UHS-I DDR50		20	ps
		UHS-I SDR104		8	ps
		All other modes		100	ps

6.10.5.17.2.1 Default Speed Mode

Table 6-69, Figure 6-85, Table 6-70, and Figure 6-86 present timing requirements and switching characteristics for MMC1/2 – Default Speed Mode.

Table 6-69. MMC1/2 Timing Requirements – Default Speed Mode

see Figure 6-85

NO.			MIN	MAX	UNIT
DS1	$t_{su}(cmdV-clkH)$	Setup time, MMC[x]_CMD valid before MMC[x]_CLK rising edge	2.15		ns
DS2	$t_h(clkH-cmdV)$	Hold time, MMC[x]_CMD valid after MMC[x]_CLK rising edge	4.56		ns
DS3	$t_{su}(dV-clkH)$	Setup time, MMC[x]_DAT[3:0] valid before MMC[x]_CLK rising edge	2.15		ns
DS4	$t_h(clkH-dV)$	Hold time, MMC[x]_DAT[3:0] valid after MMC[x]_CLK rising edge	4.56		ns

- A. x = 1, 2 for MMC1 and MMC2
- B. x = 1, 2 for MMC1 and MMC2

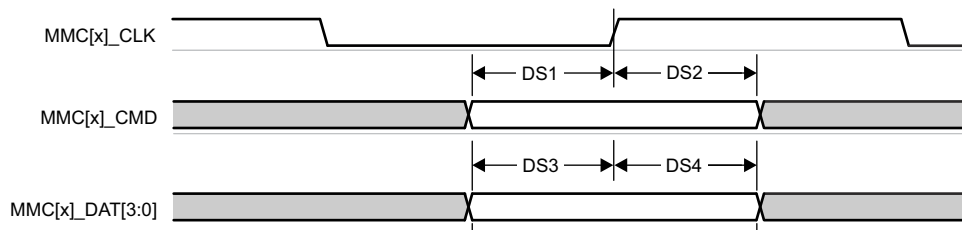

Figure 6-85. MMC1/2 – Default Speed – Receive Mode

Table 6-70. MMC1/2 Switching Characteristics – Default Speed Mode

see Figure 6-86

NO.	PARAMETER	MIN	MAX	UNIT
	$f_{op}(clk)$		25	MHz
DS5	$t_c(clk)$	40		ns
DS6	$t_w(clkH)$	18.7		ns
DS7	$t_w(clkL)$	18.7		ns
DS8	$t_d(clkL-cmdV)$	-3.53	3.53	ns
DS9	$t_d(clkL-dV)$	-3.53	3.53	ns

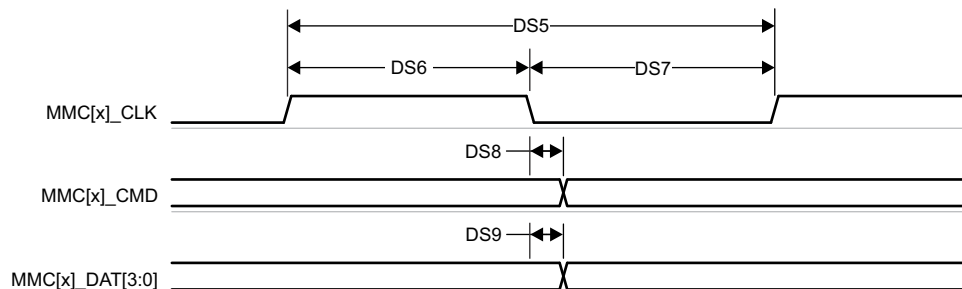

Figure 6-86. MMC1/2 – Default Speed – Transmit Mode

6.10.5.17.2.2 High Speed Mode

Table 6-71, Figure 6-87, Table 6-72, and Figure 6-88 present timing requirements and switching characteristics for MMC1/2 – High Speed Mode.

Table 6-71. MMC1/2 Timing Requirements – High Speed Mode

see Figure 6-87

NO.			MIN	MAX	UNIT
HS1	$t_{su}(cmdV-clkH)$	Setup time, MMC[x]_CMD valid before MMC[x]_CLK rising edge	2.15		ns
HS2	$t_h(clkH-cmdV)$	Hold time, MMC[x]_CMD valid after MMC[x]_CLK rising edge	2.26		ns
HS3	$t_{su}(dV-clkH)$	Setup time, MMC[x]_DAT[3:0] valid before MMC[x]_CLK rising edge	2.15		ns
HS4	$t_h(clkH-dV)$	Hold time, MMC[x]_DAT[3:0] valid after MMC[x]_CLK rising edge	2.26		ns

A. x = 1, 2 for MMC1 and MMC2

B. x = 1, 2 for MMC1 and MMC2

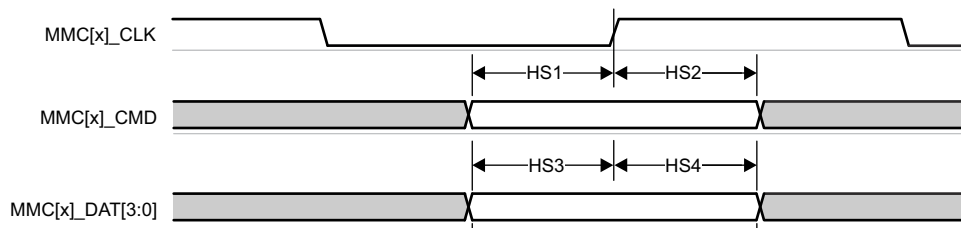

Figure 6-87. MMC1 /2– High Speed – Receive Mode

Table 6-72. MMC1/2 Switching Characteristics – High Speed Mode

see Figure 6-88

NO.		PARAMETER	MIN	MAX	UNIT
	$f_{op}(clk)$	Operating frequency, MMC[x]_CLK		50	MHz
HS5	$t_c(clk)$	Cycle time, MMC[x]_CLK	20		ns
HS6	$t_w(clkH)$	Pulse duration, MMC[x]_CLK high	9.2		ns
HS7	$t_w(clkL)$	Pulse duration, MMC[x]_CLK low	9.2		ns
HS8	$t_d(clkL-cmdV)$	Delay time, MMC[x]_CLK falling edge to MMC[x]_CMD transition	-2.07	2.07	ns
HS9	$t_d(clkL-dV)$	Delay time, MMC[x]_CLK falling edge to MMC[x]_DAT[3:0] transition	-2.07	2.07	ns

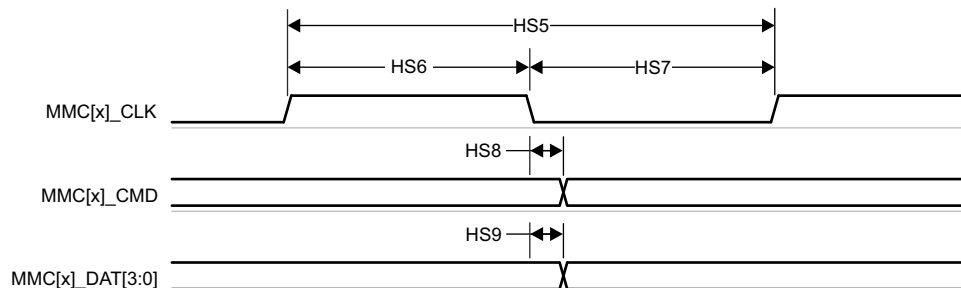

Figure 6-88. MMC1/2 – High Speed – Transmit Mode

6.10.5.17.2.3 UHS-I SDR12 Mode

Table 6-73, Figure 6-89, Table 6-74, and Figure 6-90 present timing requirements and switching characteristics for MMC1/2 – UHS-I SDR12 Mode.

Table 6-73. MMC1/2 Timing Requirements – UHS-I SDR12 Mode

see Figure 6-89

NO.			MIN	MAX	UNIT
SDR121	$t_{su(cmdV-clkH)}$	Setup time, MMC[x]_CMD valid before MMC[x]_CLK rising edge	5.46		ns
SDR122	$t_{h(clkH-cmdV)}$	Hold time, MMC[x]_CMD valid after MMC[x]_CLK rising edge	1.67		ns
SDR123	$t_{su(dV-clkH)}$	Setup time, MMC[x]_DAT[3:0] valid before MMC[x]_CLK rising edge	5.46		ns
SDR124	$t_{h(clkH-dV)}$	Hold time, MMC[x]_DAT[3:0] valid after MMC[x]_CLK rising edge	1.67		ns

- A. x = 1, 2 for MMC1 and MMC2
- B. x = 1, 2 for MMC1 and MMC2

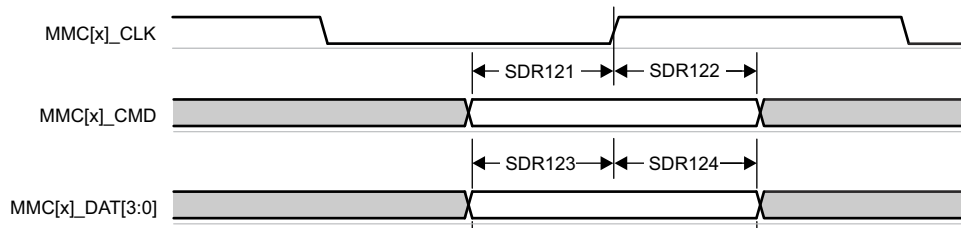

Figure 6-89. MMC1/2 – UHS-I SDR12 – Receive Mode

Table 6-74. MMC1/2 Switching Characteristics – UHS-I SDR12 Mode

see Figure 6-90

NO.		PARAMETER	MIN	MAX	UNIT
	$f_{op(clk)}$	Operating frequency, MMC[x]_CLK		25	MHz
SDR125	$t_{c(clk)}$	Cycle time, MMC[x]_CLK	40		ns
SDR126	$t_{w(clkH)}$	Pulse duration, MMC[x]_CLK high	18.7		ns
SDR127	$t_{w(clkL)}$	Pulse duration, MMC[x]_CLK low	18.7		ns
SDR128	$t_{d(clkH-cmdV)}$	Delay time, MMC[x]_CLK rising edge to MMC[x]_CMD transition	1.2	13.55	ns
SDR129	$t_{d(clkH-dV)}$	Delay time, MMC[x]_CLK rising edge to MMC[x]_DAT[3:0] transition	1.2	13.55	ns

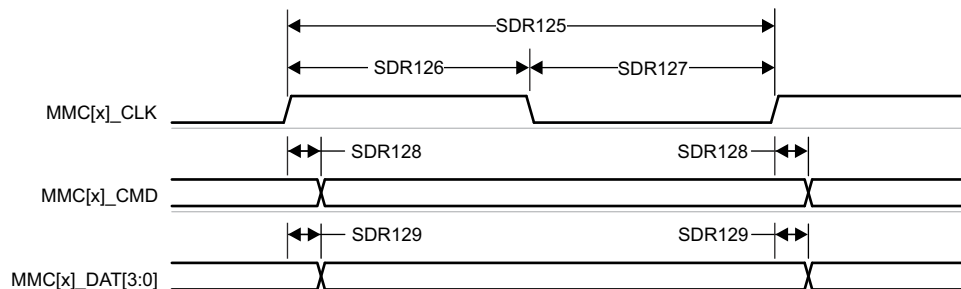

Figure 6-90. MMC1/2 – UHS-I SDR12 – Transmit Mode

6.10.5.17.2.4 UHS-I SDR25 Mode

Table 6-75, Figure 6-91, Table 6-76, and Figure 6-92 present timing requirements and switching characteristics for MMC1/2 – UHS-I SDR25 Mode.

Table 6-75. MMC1/2 Timing Requirements – UHS-I SDR25 Mode

see Figure 6-91

NO.			MIN	MAX	UNIT
SDR251	$t_{su(cmdV-clkH)}$	Setup time, MMC[x]_CMD valid before MMC[x]_CLK rising edge	2.1		ns
SDR252	$t_{h(clkH-cmdV)}$	Hold time, MMC[x]_CMD valid after MMC[x]_CLK rising edge	1.67		ns
SDR253	$t_{su(dV-clkH)}$	Setup time, MMC[x]_DAT[3:0] valid before MMC[x]_CLK rising edge	2.1		ns
SDR254	$t_{h(clkH-dV)}$	Hold time, MMC[x]_DAT[3:0] valid after MMC[x]_CLK rising edge	1.67		ns

A. x = 1, 2 for MMC1 and MMC2

B. x = 1, 2 for MMC1 and MMC2

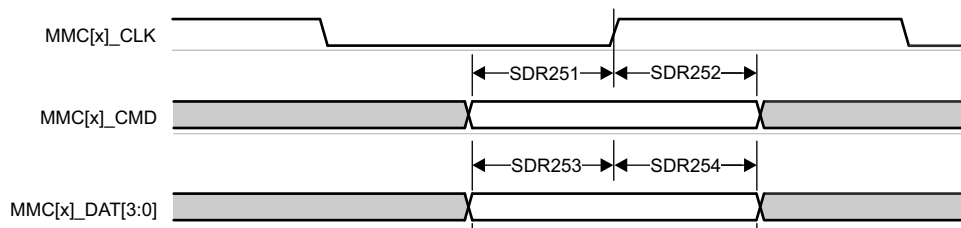

Figure 6-91. MMC1/2 – UHS-I SDR25 – Receive Mode

Table 6-76. MMC1/2 Switching Characteristics – UHS-I SDR25 Mode

see Figure 6-92

NO.	PARAMETER	MIN	MAX	UNIT
	$f_{op(clk)}$		50	MHz
SDR255	$t_{c(clk)}$	20		ns
SDR256	$t_{w(clkH)}$	9.2		ns
SDR257	$t_{w(clkL)}$	9.2		ns
SDR258	$t_{d(clkH-cmdV)}$	2.4	9.37	ns
SDR259	$t_{d(clkH-dV)}$	2.4	9.37	ns

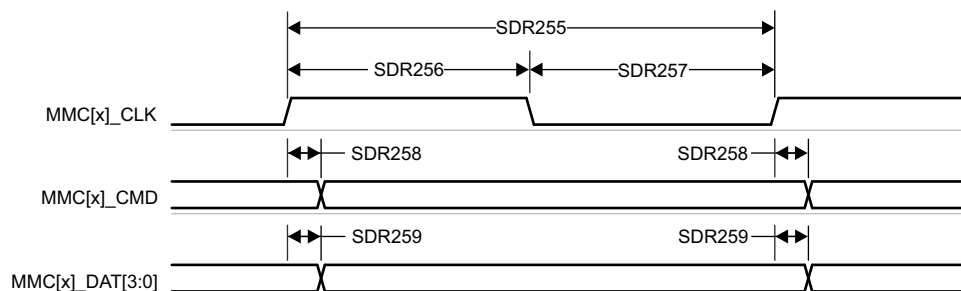

Figure 6-92. MMC1/2 – UHS-I SDR25 – Transmit Mode

6.10.5.17.2.5 UHS-I SDR50 Mode

Table 6-77, and Figure 6-93 presents switching characteristics for MMC1/2 – UHS-I SDR50 Mode.

Table 6-77. MMC1/2 Switching Characteristics – UHS-I SDR50 Mode

see Figure 6-93

NO.	PARAMETER		MIN	MAX	UNIT
	$f_{op}(clk)$	Operating frequency, MMC[x]_CLK		100	MHz
SDR505	$t_{c}(clk)$	Cycle time, MMC[x]_CLK	10		ns
SDR506	$t_{w}(clkH)$	Pulse duration, MMC[x]_CLK high	4.45		ns
SDR507	$t_{w}(clkL)$	Pulse duration, MMC[x]_CLK low	4.45		ns
SDR508	$t_{d}(clkH-cmdV)$	Delay time, MMC[x]_CLK rising edge to MMC[x]_CMD transition	1.2	6.35	ns
SDR509	$t_{d}(clkH-dV)$	Delay time, MMC[x]_CLK rising edge to MMC[x]_DAT[3:0] transition	1.2	6.35	ns

A. x = 1, 2 for MMC1 and MMC2

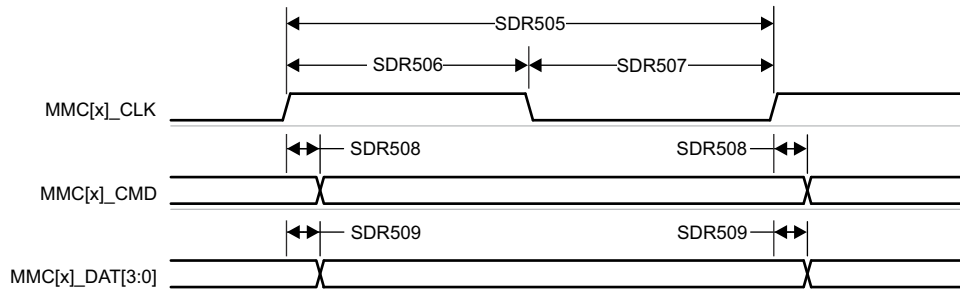

Figure 6-93. MMC1/2 – UHS-I SDR50 – Transmit Mode

6.10.5.17.2.6 UHS-I DDR50 Mode

Table 6-78 and Figure 6-94 present switching characteristics for MMC1/2 – UHS-I DDR50 Mode.

Table 6-78. MMC1/2 Switching Characteristics – UHS-I DDR50 Mode

see Figure 6-94

NO.	PARAMETER		MIN	MAX	UNIT
	$f_{op}(clk)$	Operating frequency, MMC[x]_CLK		50	MHz
DDR505	$t_{c}(clk)$	Cycle time, MMC[x]_CLK	20		ns
DDR506	$t_{w}(clkH)$	Pulse duration, MMC[x]_CLK high	9.2		ns
DDR507	$t_{w}(clkL)$	Pulse duration, MMC[x]_CLK low	9.2		ns
DDR508	$t_{d}(clkH-cmdV)$	Delay time, MMC[x]_CLK rising edge to MMC[x]_CMD transition	1.12	3.46	ns
DDR509	$t_{d}(clk-dV)$	Delay time, MMC[x]_CLK transition to MMC[x]_DAT[3:0] transition	1.12	6.12	ns

A. x = 1, 2 for MMC1 and MMC2

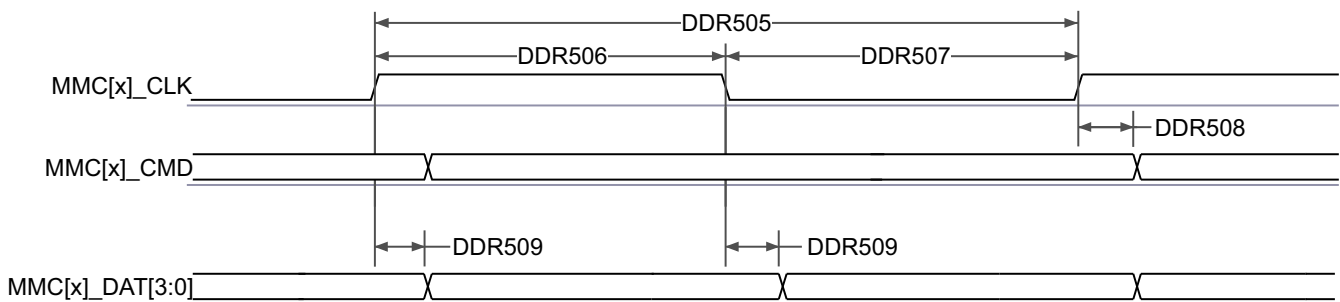

Figure 6-94. MMC1/2 – UHS-I DDR50 – Transmit Mode

6.10.5.17.2.7 UHS-I SDR104 Mode

Table 6-79, and Figure 6-95 present switching characteristics for MMC1/2 – UHS-I SDR104 Mode.

Table 6-79. MMC1/2 Switching Characteristics – UHS-I SDR104 Mode

see Figure 6-95

NO.	PARAMETER		MIN	MAX	UNIT
	$f_{op}(clk)$	Operating frequency, MMC[x]_CLK		200	MHz
SDR1045	$t_{c}(clk)$	Cycle time, MMC[x]_CLK	5		ns
SDR1046	$t_{w}(clkH)$	Pulse duration, MMC[x]_CLK high	2.12		ns
SDR1047	$t_{w}(clkL)$	Pulse duration, MMC[x]_CLK low	2.12		ns
SDR1048	$t_{d}(clkH-cmdV)$	Delay time, MMC[x]_CLK rising edge to MMC[x]_CMD transition	1.07	3.21	ns
SDR1049	$t_{d}(clkH-dv)$	Delay time, MMC[x]_CLK rising edge to MMC[x]_DAT[3:0] transition	1.07	3.21	ns

A. x = 1, 2 for MMC1 and MMC2

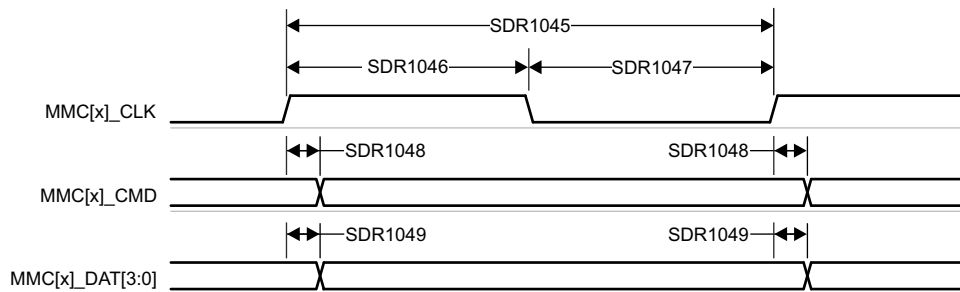

Figure 6-95. MMC1/2 – UHS-I SDR104 – Transmit Mode

6.10.5.18 CPTS

Table 6-80 represents CPTS timing conditions.

Table 6-80. CPTS Timing Conditions

PARAMETER	DESCRIPTION	MIN	MAX	UNIT
INPUT CONDITIONS				
SR_i	Input slew rate	0.5	5	V/ns
OUTPUT CONDITIONS				
C_L	Output load capacitance	2	10	pF

Section 6.10.5.18.1, Section 6.10.5.18.2, Figure 6-96, and Figure 6-97 present timing requirements and switching characteristics of the CPTS interface.

6.10.5.18.1 CPTS Timing Requirements

see Figure 6-96

NO.	PARAMETER		MIN	MAX	UNIT
T1	$t_{w}(HWnTSPUSHH)$	Pulse duration, HWnTSPUSH ⁽²⁾ high	$12P + 2^{(1)}$		ns
T2	$t_{w}(HWnTSPUSHL)$	Pulse duration, HWnTSPUSH ⁽²⁾ low	$12P + 2^{(1)}$		ns
T3	$t_{c}(RFT_CLK)$	Cycle time, RFT_CLK	5	8	ns
T4	$t_{w}(RFT_CLKH)$	Pulse duration, RFT_CLK high	$0.45 * T^{(3)}$		ns
T5	$t_{w}(RFT_CLKL)$	Pulse duration, RFT_CLK low	$0.45 * T^{(3)}$		ns

(1) P = functional clock period in ns.

(2) In HWnTSPUSH, n = 1 to 2.

(3) T = RFT_CLK period in ns.

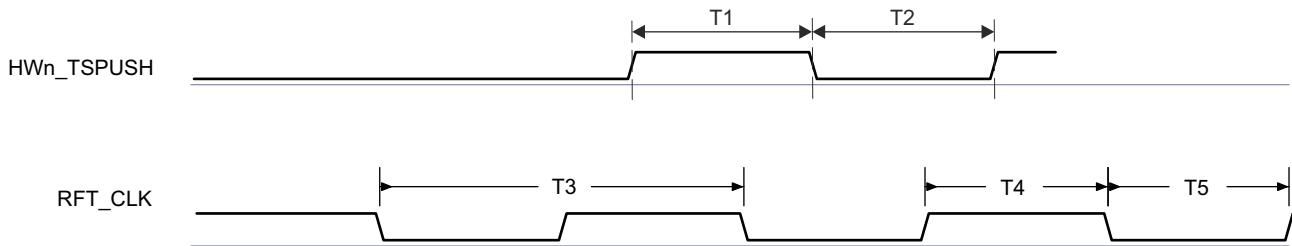

Figure 6-96. CPTS Timing Requirements

6.10.5.18.2 CPTS Switching Characteristics

see Figure 6-97

NO.	PARAMETER		SOURCE	MIN	MAX	UNIT
T6	$t_{w(TS_COMPH)}$	Pulse duration, TS_COMP high		$36P - 2^{(1)}$		ns
T7	$t_{w(TS_COMPL)}$	Pulse duration, TS_COMP low		$36P - 2^{(1)}$		ns
T8	$t_{w(TS_SYNCH)}$	Pulse duration, TS_SYNC high		$36P - 2^{(1)}$		ns
T9	$t_{w(TS_SYNCL)}$	Pulse duration, TS_SYNC low		$36P - 2^{(1)}$		ns
T10	$t_{w(SYNcN_OUTH)}$	Pulse duration, SYNcN_OUT ⁽²⁾ high	TS_SYNC	$36P - 2^{(1)}$		ns
			TS_GENF	$5P - 2^{(1)}$		ns
T11	$t_{w(SYNcN_OUTL)}$	Pulse duration, SYNcN_OUT ⁽²⁾ low	TS_SYNC	$36P - 2^{(1)}$		ns
			TS_GENF	$5P - 2^{(1)}$		ns

- (1) P = functional clock period in ns.
- (2) n = 0 to 3 in SYNcN_OUT

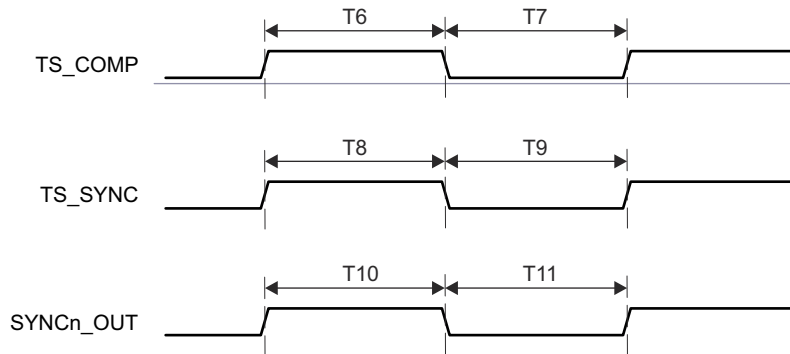

Figure 6-97. CPTS Switching Characteristics

For more information, see *Navigator Subsystem (NAVSS)* section in *Data Movement Architecture (DMA)* chapter in the device TRM.

6.10.5.19 OSPI

For more details about features and additional description information on the device Octal Serial Peripheral Interface, see the corresponding sections within [Signal Descriptions](#) and *Detailed Description*.

Table 6-81 represents OSPI timing conditions.

Table 6-81. OSPI Timing Conditions

PARAMETER			MIN	MAX	UNIT
INPUT CONDITIONS					
SR _I	Input slew rate	3.3 V	2	6	V/ns
		All other modes	1	6	V/ns
OUTPUT CONDITIONS					
C _L	Output load capacitance	All modes	3	10	pF

Table 6-81. OSPI Timing Conditions (continued)

PARAMETER			MIN	MAX	UNIT
PCB CONNECTIVITY REQUIREMENTS					
t_d (Trace Delay)	Propagation delay OSPI_CLK trace	No Loopback; Internal Pad Loopback		450	ps
	Propagation delay OSPI_LBCKLO trace	External Board Loopback	$2*L-30^{(2)}$	$2*L+30^{(2)}$	ps
	Propagation delay OSPI_DQS trace	DQS	$L-30^{(2)}$	$L+30^{(2)}$	ps
t_d (Trace Mismatch Delay)	Propagation delay mismatch OSPI_D[i:0] ⁽¹⁾ , OSPI_CS <i>n</i> relative to OSPI_CLK	All modes		60	ps

(1) i in D[i:0] = 0 to 7 for OSPI0; i in [i:0] = 3 for OSPI1

(2) L = Propagation delay of OSPI_CLK trace

6.10.5.19.1 OSPI0 PHY Mode

6.10.5.19.1.1 OSPI With Data Training

Note

I/O timing requirements and switching characteristics are not applicable when OSPI is used with data training. Follow the [OSPI and QSPI Board Design and Layout Guidelines](#) section to ensure proper operation.

6.10.5.19.1.1.1 OSPI Switching Characteristics – Data Training

PARAMETER	DESCRIPTION	MODE	MIN	MAX	UNIT
$t_{c}(\text{CLK})$	Cycle time, CLK	DDR, 1.8V	6	7.5	ns
		DDR, 3.3V	7.5	7.5	ns
$t_{c}(\text{CLK})$	Cycle time, CLK	SDR, 1.8V	6	7.5	ns
		SDR, 3.3V	7.5	7.5	ns

6.10.5.19.1.2 OSPI Without Data Training

Note

The I/O Timings provided in this section are only applicable when data training is not implemented. Additionally, the I/O Timings are valid only for some OSPI usage modes when the corresponding DLL Delays are configured as described in [Table 6-82](#) found in this section.

[Section 6.10.5.19.1.2.4](#), [Section 6.10.5.19.1.2.2](#), [Section 6.10.5.19.1.2](#), and [Section 6.10.5.19.1.2](#) present switching characteristics for OSPI DDR and SDR Mode.

6.10.5.19.1.2.1 OSPI Timing Requirements – SDR Mode

Table 6-82. OSPI DLL Delay Mapping - SDR Timing Modes

MODE	OSPI_PHY_CONFIGURATION_REG BIT FIELD	DELAY VALUE
All modes	PHY_CONFIG_TX_DLL_DELAY_FLD	0x0
	PHY_CONFIG_RX_DLL_DELAY_FLD	0x0

Table 6-83. OSPI Timing Requirements – SDR Mode

NO.	PARAMETER	DESCRIPTION	MODE	MIN	MAX	UNIT
O21	$t_{su}(\text{D-LBCLK})$	Setup time, D[i:0] valid before active LBCLK input (DQS) edge ⁽¹⁾	1.8V, External Board Loopback	0.6		ns
			3.3V, External Board Loopback	0.9		ns
O22	$t_{h}(\text{LBCLK-D})$	Hold time, D[i:0] valid after active LBCLK input (DQS) edge ⁽¹⁾	1.8V, External Board Loopback	1.7		ns
			3.3V, External Board Loopback	2		ns

(1) i in [i:0] = 7 for OSPI0, i in [i:0] = 3 for OSPI1

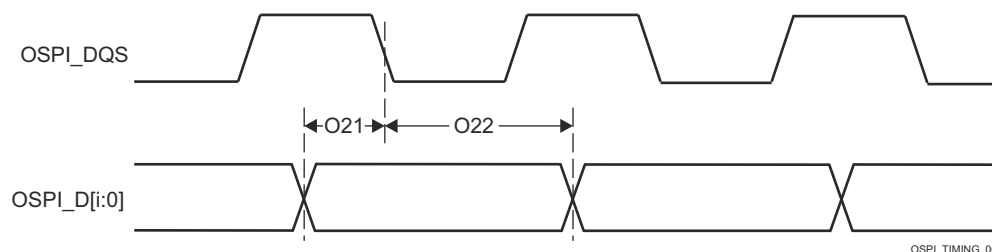

Figure 6-98. OSPI Timing Requirements – SDR, External Loopback Clock

6.10.5.19.1.2.2 OSPI Switching Characteristics – SDR Mode

NO.	PARAMETER	DESCRIPTION	MODE	MIN	MAX	UNIT
O7	t _c (CLK)	Cycle time, CLK	1.8V	7		ns
			3.3V	7.5		ns
O8	t _w (CLKL)	Pulse duration, CLK low		-0.3+0.475*P (2)		ns
O9		Pulse duration, CLK high		-0.3+0.475*P (2)		ns
O10	t _d (CSn-CLK)	Delay time, CSn[3:0] active edge to CLK rising edge	1.8V	0.475 * P + 0.975 * M * R - 7 (2) (3) (5)	0.525 * P + 1.025 * M * R + 1 (2) (3) (5)	ns
			3.3V	0.475 * P + 0.975 * M * R - 7(2) (3) (5)	0.525 * P + 1.025 * M * R + 1 (2) (3) (5)	ns
O11	t _d (CLK-CSn)	Delay time, CLK rising edge to CSn inactive edge	1.8V	0.475 * P + 0.975 * N * R - 1 (2) (4) (5)	0.525 * P + 1.025 * N * R + 1 (2) (4) (5)	ns
			3.3V	0.475 * P + 0.975 * N * R - 1 (2) (4) (5)	0.525 * P + 1.025 * N * R + 1(2) (4) (5)	ns
O12	t _d (CLK-D)	Delay time, CLK active edge to D[i:0] transition ⁽¹⁾	1.8V	-1.16	1.25	ns
			3.3V	-1.33	1.51	ns

- (1) i in [i:0] = 7 for OSPI0, i in [i:0] = 3 for OSPI1
- (2) P = CLK cycle time = SCLK period
- (3) M = OSPI_DEV_DELAY_REG[D_INIT_FLD]
- (4) N = OSPI_DEV_DELAY_REG[D_AFTER_FLD]
- (5) R = refclk

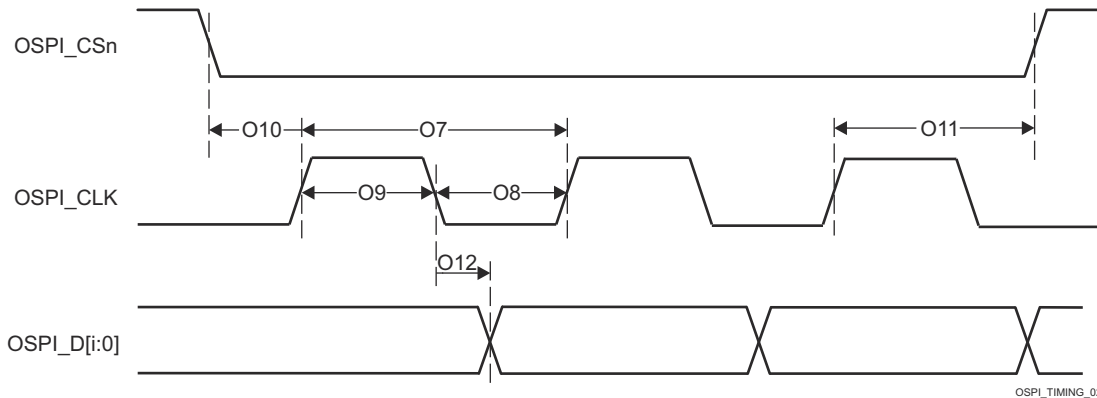

Figure 6-99. OSPI Switching Characteristics – SDR

Section 6.10.5.19.1.2.3, Section 6.10.5.19.1.2.1, Section 6.10.5.19.1.2.2, Section 6.10.5.19.1.2.2, and Figure 6-98 presents timing requirements for OSPI DDR and SDR Mode.

6.10.5.19.1.2.3 OSPI Timing Requirements – DDR Mode

Table 6-84. OSPI DLL Delay Mapping - DDR Timing Modes

MODE	OSPI_PHY_CONFIGURATION_REG BIT FIELD	OSPI0	OSPI1
		DELAY VALUE	
TRANSMIT			
1.8V	PHY_CONFIG_TX_DLL_DELAY_FLD	0x54	0x54
3.3V	PHY_CONFIG_TX_DLL_DELAY_FLD	0x55	0x5C
RECEIVE			

Table 6-84. OSPI DLL Delay Mapping - DDR Timing Modes (continued)

MODE	OSPI_PHY_CONFIGURATION_REG BIT FIELD	OSPI0	OSPI1
		DELAY VALUE	
1.8V, DQS	PHY_CONFIG_RX_DLL_DELAY_FLD	0x23	0x29
3.3V, DQS	PHY_CONFIG_RX_DLL_DELAY_FLD	0x47	0x42
All other modes	PHY_CONFIG_RX_DLL_DELAY_FLD	0x0	0x0

Table 6-85. OSPI Timing Requirements – DDR Mode

NO.	PARAMETER	DESCRIPTION	MODE	MIN	MAX	UNIT
O15	$t_{su}(D-LBCLK)$	Setup time, D[i:0] valid before active LBCLK (DQS) edge ⁽¹⁾	1.8V, External Board Loopback	0.52		ns
			3.3V, External Board Loopback	1.97		ns
O16	$t_h(LBCLK-D)$	Hold time, D[i:0] valid after active LBCLK (DQS) edge ⁽¹⁾	1.8V, External Board Loopback	1.24 ⁽²⁾		ns
			3.3V, External Board Loopback	1.44 ⁽²⁾		ns
O17	$t_{su}(D-DQS)$	Setup time, DQS edge to D[i:0] transition ⁽¹⁾	1.8V, DQS	-0.46		ns
			3.3V, DQS	-0.66		ns
O18	$t_h(DQS-D)$	Hold time, DQS edge to D[i:0] transition ⁽¹⁾	1.8V, DQS	3.59		ns
			3.3V, DQS	8.89		ns

(1) i in [i:0] = 7 for OSPI0, i in [i:0] = 3 for OSPI1

(2) This Hold time requirement is larger than the Hold time provided by a typical flash device. Therefore, the trace length between the SoC and flash device must be sufficiently long enough to ensure that the Hold time is met at the SoC. Refer to [OSPI and QSPI Board Design and Layout Guidelines](#) for more details.

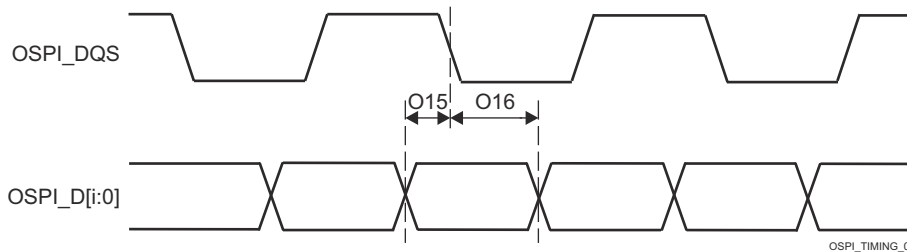

Figure 6-100. OSPI Timing Requirements – DDR, External Loopback Clock and DQS

6.10.5.19.1.2.4 OSPI Switching Characteristics – DDR Mode

NO.	PARAMETER	DESCRIPTION	MODE	MIN	MAX	UNIT
O1	$t_c(CLK)$	Cycle time, CLK	1.8V	19		ns
			3.3V	19		ns
O2	$t_w(CLK_L)$	Pulse duration, CLK low		0.475 * P - 0.3 ⁽²⁾		ns
O3	$t_w(CLK_H)$	Pulse duration, CLK high		0.475 * P - 0.3 ⁽²⁾		ns
O4	$t_d(CLK-CS_n)$	Delay time, CS _n active edge to CLK rising edge	1.8V	0.475 * P + 0.975 * M * R - 7 ^{(2) (3) (5)}	0.525 * P + 1.025 * M * R + 1 ^{(2) (3) (5)}	ns
			3.3V	0.475 * P + 0.975 * M * R - 7 ^{(2) (3) (5)}	0.525 * P + 1.025 * M * R + 1 ^{(2) (3) (5)}	ns
O5	$t_d(CLK-CS_n)$	Delay time, CLK rising edge to CS _n inactive edge	1.8V	0.475 * P + 0.975 * N * R - 7 ^{(2) (4) (5)}	0.525 * P + 1.025 * N * R + 1 ^{(2) (4) (5)}	ns
			3.3V, OSPI0 DDR TX; 3.3V, OSPI1 DDR TX	0.475 * P + 0.975 * N * R - 7 ^{(2) (4) (5)}	0.525 * P + 1.025 * N * R + 1 ^{(2) (4) (5)}	ns

NO.	PARAMETER	DESCRIPTION	MODE	MIN	MAX	UNIT
O6	$t_{d(\text{CLK-D})}$	Delay time, CLK active edge to D[i:0] transition ⁽¹⁾	1.8V, OSPI0 DDR TX; 1.8V, OSPI1 DDR TX	-7.71	-1.56	ns
			3.3V, OSPI0 DDR TX; 3.3V, OSPI1 DDR TX	-7.71	-1.56	ns

- (1) i in [i:0] = 7 for OSPI0, i in [i:0] = 3 for OSPI1
- (2) P = CLK cycle time = SCLK period
- (3) N = OSPI_DEV_DELAY_REG[D_INIT_FLD]
- (4) N = OSPI_DEV_DELAY_REG[D_AFTER_FLD]
- (5) R = refclk

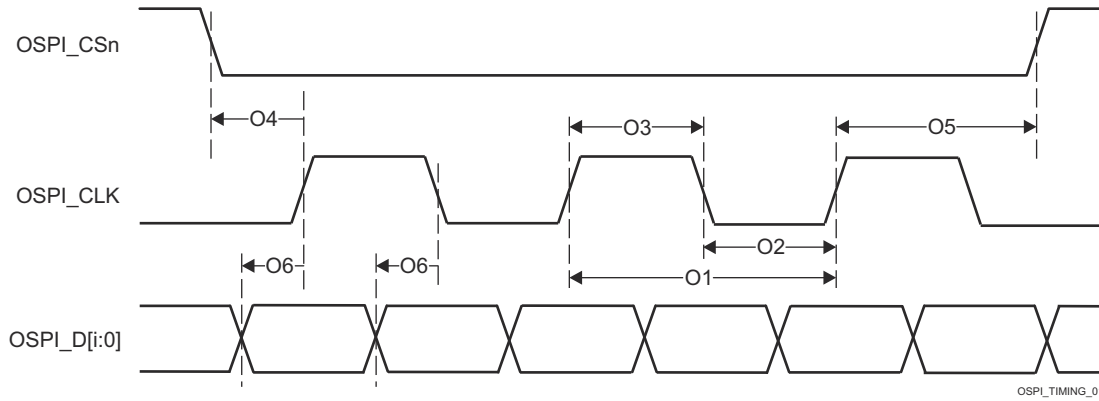

Figure 6-101. OSPI Switching Characteristics – DDR

6.10.5.19.2 OSPI0 Tap Mode

6.10.5.19.2.1 OSPI0 Tap SDR Timing

Table 6-86, Figure 6-102, Table 6-87, and Figure 6-103 present timing requirements and switching characteristics for OSPI0 Tap SDR Mode.

Table 6-86. OSPI0/1 Timing Requirements – Tap SDR Mode

see Figure 6-102

NO.			MODE	MIN	MAX	UNIT
O19	$t_{su(D-CLK)}$	Setup time, OSPI0/1_D[7:0] valid before active OSPI0/1_CLK edge	No Loopback	(10.4 - (0.975T ⁽¹⁾ R ⁽²⁾))		ns
O20	$t_{h(CLK-D)}$	Hold time, OSPI0/1_D[7:0] valid after active OSPI0/1_CLK edge	No Loopback	(-0.2 + (0.975T ⁽¹⁾ R ⁽²⁾))		ns

(1) T = OSPI_RD_DATA_CAPTURE_REG[DELAY_FLD]

(2) R = refclk cycle time in ns

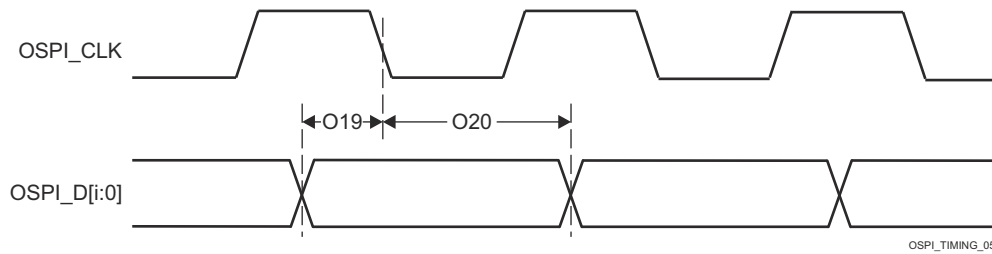

Figure 6-102. OSPI0/1 Timing Requirements – Tap SDR, No Loopback

Table 6-87. OSPI0/1 Switching Characteristics – Tap SDR Mode

see [Figure 6-103](#)

NO.	PARAMETER	MODE	MIN	MAX	UNIT
O7	$t_{c(CLK)}$	Cycle time, OSPI0/1_CLK	20		ns
O8	$t_{w(CLKL)}$	Pulse duration, OSPI0/1_CLK low	$((0.475P^{(1)}) - 0.3)$		ns
O9	$t_{w(CLKH)}$	Pulse duration, OSPI0/1_CLK high	$((0.475P^{(1)}) - 0.3)$		ns
O10	$t_{d(CSn-CLK)}$	Delay time, OSPI0/1_CSn[3:0] active edge to OSPI0/1_CLK rising edge	$((0.475P^{(1)}) + (0.975M^{(2)}R^{(4)} - 1)$	$((0.525P^{(1)}) + (1.025M^{(2)}R^{(4)} + 1)$	ns
O11	$t_{d(CLK-CSn)}$	Delay time, OSPI0/1_CLK rising edge to OSPI0/1_CSn[3:0] inactive edge	$((0.475P^{(1)}) + (0.975N^{(3)}R^{(4)} - 1)$	$((0.525P^{(1)}) + (1.025N^{(3)}R^{(4)} + 1)$	ns
O12	$t_{d(CLK-D)}$	Delay time, OSPI0/1_CLK active edge to OSPI0/1_D[7:0] transition	-2	2	ns

- (1) P = CLK cycle time = SCLK period in ns
- (2) M = OSPI_DEV_DELAY_REG[D_INIT_FLD]
- (3) N = OSPI_DEV_DELAY_REG[D_AFTER_FLD]
- (4) R = refclk cycle time in ns

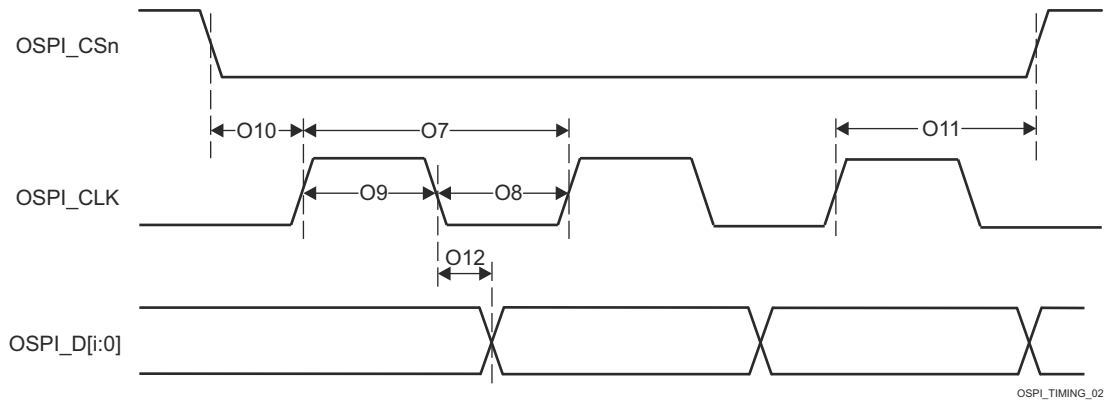

Figure 6-103. OSPI0/1 Switching Characteristics – Tap SDR, No Loopback

6.10.5.19.2.2 OSPI0 Tap DDR Timing

Table 6-88, Figure 6-104, Table 6-89, and Figure 6-105 present timing requirements and switching characteristics for OSPI0 Tap DDR Mode.

Table 6-88. OSPI0/1 Timing Requirements – Tap DDR Mode

see Figure 6-104

NO.			MODE	MIN	MAX	UNIT
O13	$t_{su(D-CLK)}$	Setup time, OSPI0/1_D[7:0] valid before active OSPI0/1_CLK edge	No Loopback	(12.04 - (0.975T ⁽¹⁾ R ⁽²⁾))		ns
O14	$t_{h(CLK-D)}$	Hold time, OSPI0/1_D[7:0] valid after active OSPI0/1_CLK edge	No Loopback	(1.84 + (0.975T ⁽¹⁾ R ⁽²⁾))		ns

(1) T = OSPI_RD_DATA_CAPTURE_REG[DELAY_FLD]

(2) R = refclk cycle time in ns

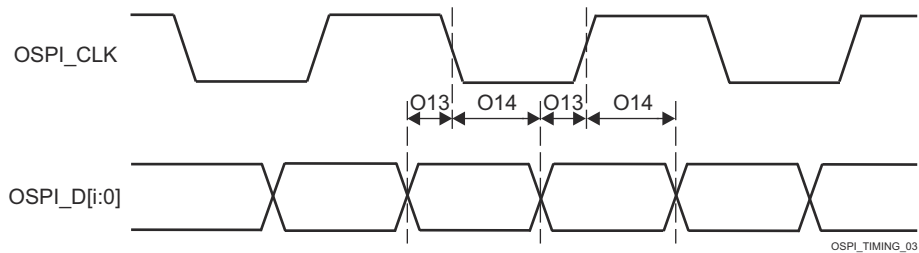

Figure 6-104. OSPI0/1 Timing Requirements – Tap DDR, No Loopback

Table 6-89. OSPI0/1 Switching Characteristics – Tap DDR Mode

see [Figure 6-105](#)

NO.	PARAMETER	MODE	MIN	MAX	UNIT
O1	$t_{c(CLK)}$ Cycle time, OSPI0/1_CLK		40		ns
O2	$t_{w(CLKL)}$ Pulse duration, OSPI0/1_CLK low		$((0.475P^{(1)}) - 0.3)$		ns
O3	$t_{w(CLKH)}$ Pulse duration, OSPI0/1_CLK high		$((0.475P^{(1)}) - 0.3)$		ns
O4	$t_{d(CSn-CLK)}$ Delay time, OSPI0/1_CSn[3:0] active edge to OSPI0/1_CLK rising edge		$((0.475P^{(1)}) + ((0.975M^{(2)}R^{(4)}) - 1)$	$((0.525P^{(1)}) + (1.025M^{(2)}R^{(4)}) + 1)$	ns
O5	$t_{d(CLK-CSn)}$ Delay time, OSPI0/1_CLK rising edge to OSPI0/1_CSn[3:0] inactive edge		$((0.475P^{(1)}) + (0.975N^{(3)}R^{(4)}) - 1)$	$((0.525P^{(1)}) + (1.025N^{(3)}R^{(4)}) + 1)$	ns
O6	$t_{d(CLK-D)}$ Delay time, OSPI0/1_CLK active edge to OSPI0/1_D[7:0] transition		$(-17.94 + (0.975T^{(5)}R^{(4)}))$	$(-1.56 + (1.025T^{(5)}R^{(4)}))$	ns

- (1) P = CLK cycle time = SCLK period in ns
- (2) M = OSPI_DEV_DELAY_REG[D_INIT_FLD]
- (3) N = OSPI_DEV_DELAY_REG[D_AFTER_FLD]
- (4) R = refclk cycle time in ns
- (5) T = OSPI_RD_DATA_CAPTURE_REG[DDR_READ_DELAY_FLD]

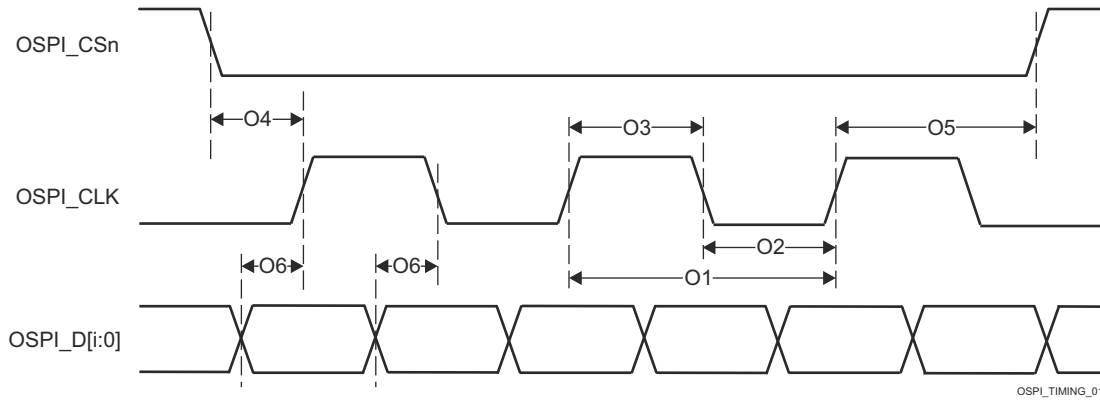

Figure 6-105. OSPI0/1 Switching Characteristics – Tap DDR, No Loopback

6.10.5.20 OLDI

6.10.5.20.1 OLDI Switching Characteristics

NO.	PARAMETER	MODE	MIN	MAX	UNIT
O1	LVDS Low-to-High Transition Time max	IOSET1	0.18	0.5	ns
O2	LVDS high-to-low Transition Time max	IOSET1	0.18	0.5	ns
O3	Transmitter Output Bit Width min	IOSET1	1	1	UI
O4	Transmitter Pulse Positions – Normalized	IOSET1	0.25	0.75	ns
O5	Variation in transmitter pulse position across Bit 7:0 pulse positions	IOSET1	-0.06	0.06	ns
O6	TxOut Channel to Channel Skew	IOSET1		110	ns
O7	Transmitter Jitter Cycle-to-Cycle	IOSET1	0.028	0.035	ns
O8	Input Total Jitter Tolerance (Includes data to clock skew, pulse position variation.)	IOSET1		0.25	ns

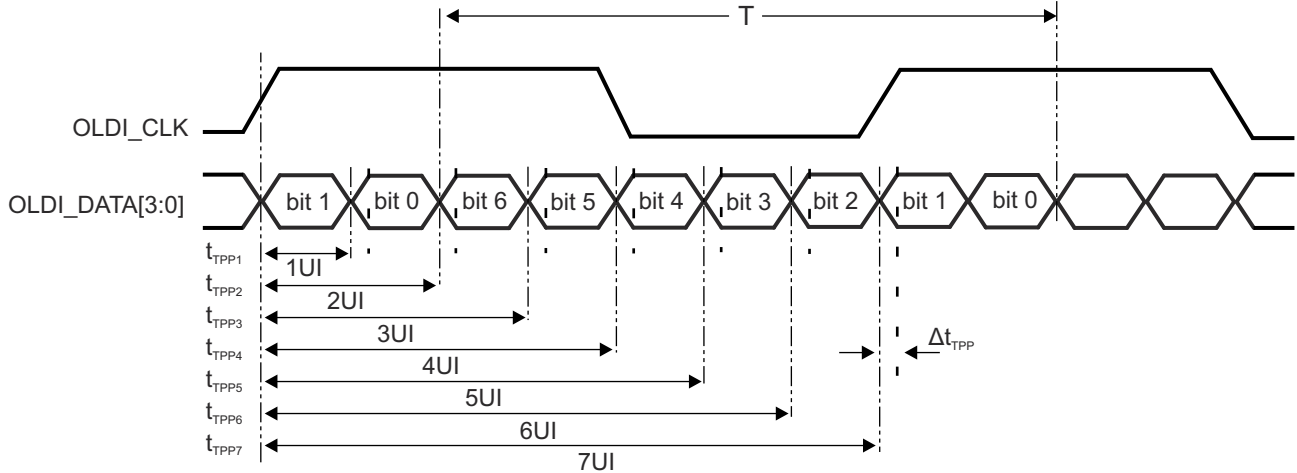

Figure 6-106. OLDI Transmitter Pulse Positions

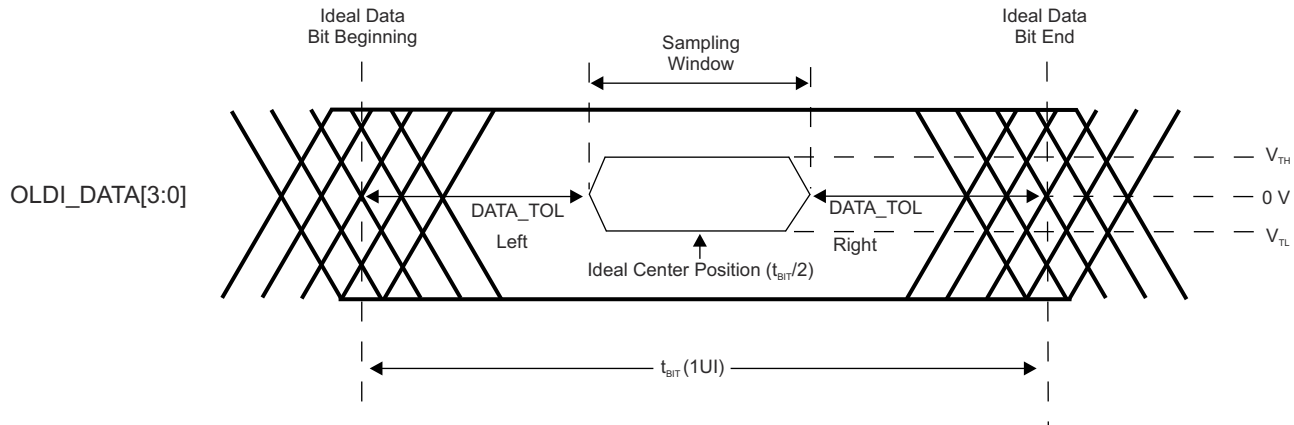

Figure 6-107. OLDI Data Output Jitter

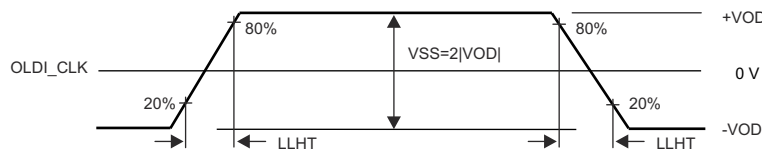

Figure 6-108. LVDS Output Transition Times

For more information, see *Display Subsystem (DSS) and Peripherals* section in *Peripherals* chapter in the device TRM.

6.10.5.21 PCIe

The PCI-Express Subsystem is compliant with the PCIe® Base Specification, Revision 4.0. Refer to the specification for timing details.

For more details about features and additional description information on the device Peripheral Component Interconnect Express, see the corresponding sections within [Signal Descriptions](#) and *Detailed Description*.

For more information, see *Peripheral Component Interconnect Express (PCIe) Subsystem* section in *Peripherals* chapter in the device TRM.

6.10.5.22 Timers

For more details about features and additional description information on the device Timers, see the corresponding sections within [Signal Descriptions](#) and *Detailed Description*.

Table 6-90 represents Timers timing conditions.

Table 6-90. Timers Timing Conditions

PARAMETER	DESCRIPTION	MODE	MIN	MAX	UNIT
INPUT CONDITIONS					
SR _I	Input slew rate	CAPTURE	0.5	5	V/ns
OUTPUT CONDITIONS					
C _L	Output load capacitance	PWM	2	10	pF

Section 6.10.5.22.1, Section 6.10.5.22.2 and Figure 6-109 present timings and switching characteristics of the Timers.

6.10.5.22.1 Timing Requirements for Timers

NO.	PARAMETER	DESCRIPTION	MODE	MIN	MAX	UNIT
T1	t _{w(TINPH)}	Pulse duration, high	CAPTURE	2.5 + 4P ⁽¹⁾		ns
T2	t _{w(TINPL)}	Pulse duration, low	CAPTURE	2.5 + 4P ⁽¹⁾		ns

(1) P = functional clock period in ns.

6.10.5.22.2 Switching Characteristics for Timers

NO.	PARAMETER	DESCRIPTION	MODE	MIN	MAX	UNIT
T3	t _{w(TOUTH)}	Pulse duration, high	PWM	-2.5 + 4P ⁽¹⁾		ns
T4	t _{w(TOURL)}	Pulse duration, low	PWM	-2.5 + 4P ⁽¹⁾		ns

(1) P = functional clock period in ns.

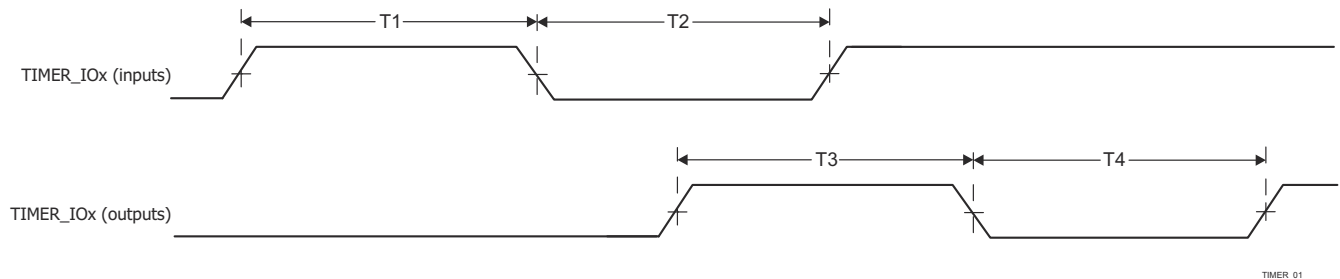

Figure 6-109. Timer Timing

For more information, see *Timers* section in *Peripherals* chapter in the device TRM.

6.10.5.23 UART

For more details about features and additional description information on the device Universal Asynchronous Receiver Transmitter, see the corresponding sections within , [Signal Descriptions](#) and *Detailed Description*.

Table 6-91 represents UART timing conditions.

Table 6-91. UART Timing Conditions

PARAMETER	DESCRIPTION	MIN	MAX	UNIT
INPUT CONDITIONS				

Table 6-91. UART Timing Conditions (continued)

PARAMETER	DESCRIPTION	MIN	MAX	UNIT
SR_I	Input slew rate	0.5	5	V/ns
OUTPUT CONDITIONS				
C_L	Output load capacitance	1	30 ⁽¹⁾	pF

- (1) This value represents an absolute maximum load capacitance. As the UART baud rate increases, it may be necessary to reduce the load capacitance to a value less than this maximum limit to provide enough timing margin for the attached device. The output rise/fall times increase as capacitive load increases, which decreases the time data is valid for the receiver of the attached devices. Therefore, it is important to understand the minimum data valid time required by the attached device at the operating baud rate. Then use the device IBIS models to verify the actual load capacitance on the UART signals does not increase the rise/fall times beyond the point where the minimum data valid time of the attached device is violated.

Section 6.10.5.23.1, Section 6.10.5.23.2, and Figure 6-110 present timing requirements and switching characteristics for UART interface.

6.10.5.23.1 Timing Requirements for UART

NO.	PARAMETER	DESCRIPTION	MODE	MIN	MAX	UNIT
4	$t_{w(rx\text{d})}$	Pulse width, receive data bit, high or low		0.95U ⁽¹⁾ (2)	1.05U ⁽¹⁾ (2)	ns
5	$t_{w(rx\text{dS})}$	Pulse width, receive start bit, low		0.95U ⁽¹⁾ (2)		ns

- (1) U = UART baud time = $1/\text{Programmed baud rate}$

- (2) This value defines the data valid time, where the input voltage is required to be above V_{IH} or below V_{IL} .

6.10.5.23.2 UART Switching Characteristics

NO.	PARAMETER	DESCRIPTION	MIN	MAX	UNIT
	$f_{(\text{baud})}$	Maximum programmable baud rate		12	Mbps
2	$t_{w(\text{TX})}$	Pulse width, transmit data bit, high or low	$U - 2^{(1)}$	$U + 2^{(1)}$	ns
3	$t_{w(\text{RTS})}$	Pulse width, transmit start bit, high or low	$U - 2^{(1)}$		ns

- (1) U = UART baud time = $1/\text{Programmed baud rate}$

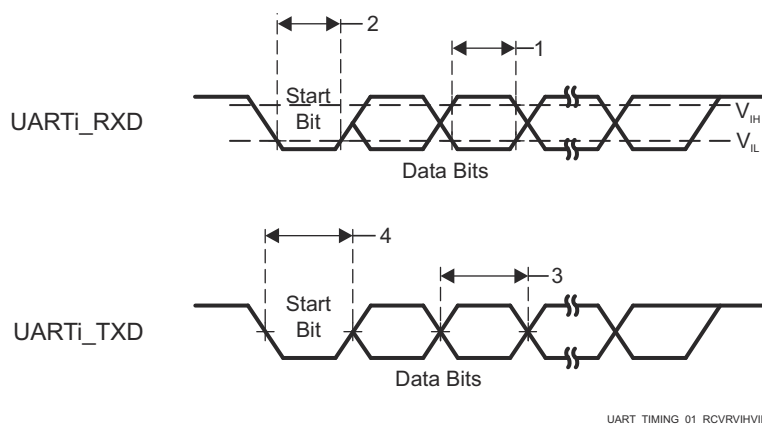
**Figure 6-110. UART Timing**

For more information, see *Universal Asynchronous Receiver/Transmitter (UART)* section in *Peripherals* chapter in the device TRM.

6.10.5.24 USB

The USB 2.0 subsystem is compliant with the Universal Serial Bus (USB) Specification, revision 2.0. Refer to the specification for timing details.

The USB 3.1 GEN1 Dual-Role Device Subsystem is compliant with the Universal Serial Bus (USB) 3.1 Specification, revision 1.0. Refer to the specification for timing details.

For more details about features and additional description information on the device Universal Serial Bus Subsystem (USB), see the corresponding sections within [Signal Descriptions](#) and *Detailed Description*.

6.10.6 Emulation and Debug

6.10.6.1 Trace

Table 6-92. Trace Timing Conditions

PARAMETER		MIN	MAX	UNIT
OUTPUT CONDITIONS				
C_L	Output load capacitance	2	5	pF
PCB CONNECTIVITY REQUIREMENTS				
t_d (Trace Mismatch)	Propagation delay mismatch across all traces		200	ps

Table 6-93 and Figure 6-111 assume testing over the recommended operating conditions and electrical characteristic conditions.

Table 6-93. Trace Switching Characteristics

NO.	PARAMETER		MIN	MAX	UNIT
1.8 V Mode					
DBTR1	t_c (TRC_CLK)	Cycle time, TRC_CLK	6.50		ns
DBTR2	t_w (TRC_CLKH)	Pulse width, TRC_CLK high	2.50		ns
DBTR3	t_w (TRC_CLKL)	Pulse width, TRC_CLK low	2.50		ns
DBTR4	t_{osu} (TRC_DATAV-TRC_CLK)	Output setup time, TRC_DATA valid to TRC_CLK edge	0.81		ns
DBTR5	t_{oh} (TRC_CLK-TRC_DATAI)	Output hold time, TRC_CLK edge to TRC_DATA invalid	0.81		ns
DBTR6	t_{osu} (TRC_CTLV-TRC_CLK)	Output setup time, TRC_CTL valid to TRC_CLK edge	0.81		ns
DBTR7	t_{oh} (TRC_CLK-TRC_CTLI)	Output hold time, TRC_CLK edge to TRC_CTL invalid	0.81		ns
3.3 V Mode					
DBTR1	t_c (TRC_CLK)	Cycle time, TRC_CLK	9.75		ns
DBTR2	t_w (TRC_CLKH)	Pulse width, TRC_CLK high	4.13		ns
DBTR3	t_w (TRC_CLKL)	Pulse width, TRC_CLK low	4.13		ns
DBTR4	t_{osu} (TRC_DATAV-TRC_CLK)	Output setup time, TRC_DATA valid to TRC_CLK edge	1.22		ns
DBTR5	t_{oh} (TRC_CLK-TRC_DATAI)	Output hold time, TRC_CLK edge to TRC_DATA invalid	1.22		ns
DBTR6	t_{osu} (TRC_CTLV-TRC_CLK)	Output setup time, TRC_CTL valid to TRC_CLK edge	1.22		ns
DBTR7	t_{oh} (TRC_CLK-TRC_CTLI)	Output hold time, TRC_CLK edge to TRC_CTL invalid	1.22		ns

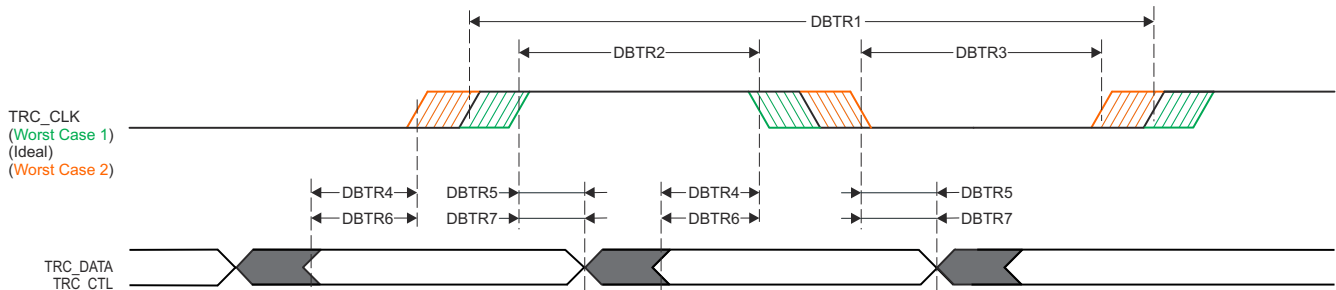

SPRSP08_Debug_01

Figure 6-111. Trace Switching Characteristics

6.10.6.2 JTAG

For more details about features and additional description information on the device IEEE 1149.1 Standard–Test–Access Port, see the corresponding sections within [Signal Descriptions](#) and *Detailed Description*.

Note

The JTAG signals are split across two IO power domains on the device. Timings parameters defined in this section only apply when the two IO power domains are operating at the same voltage and level-shifters are not inserted into the signal path. Values for the following timing parameters are not defined when operating the two IO power domains at different voltages since propagation delay through the device IO buffers differ when some are operating at 1.8 V while others are operating at 3.3 V. This effectively reduces timing margin beyond the values defined in this section. The JTAG interface is still expected to function when the two IO power domains are operated at different voltages, assuming the system designer has implemented appropriate level-shifters and the operating frequency is reduced to accommodate additional delay inserted by the level-shifters and IO buffers operating at different voltages.

Table 6-94. JTAG Timing Conditions

PARAMETER		MIN	MAX	UNIT
Input Conditions				
SR _I	Input slew rate	0.50	2.00	V/ns
Output Conditions				
C _L	Output load capacitance	5	15	pF
PCB CONNECTIVITY REQUIREMENTS				
t _d (Trace Delay)	Propagation delay of each trace	83.5	1000 ⁽¹⁾	ps
t _d (Trace Mismatch Delay)	Propagation delay mismatch across all traces		100	ps

- (1) Maximum propagation delay associated with the JTAG signal traces has a significant impact on maximum TCK operating frequency. It may be possible to increase the trace delay beyond this value, but the operating frequency of TCK must be reduced to account for the additional trace delay.

6.10.6.2.1 JTAG Electrical Data and Timing

Section 6.10.6.2.1.1, Section 6.10.6.2.1.2, and Figure 6-112 assume testing over the recommended operating conditions and electrical characteristic conditions.

6.10.6.2.1.1 JTAG Timing Requirements

See Figure 6-112

NO.			MIN	MAX	UNIT
J1	t _c (TCK)	Cycle time minimum, TCK	46.5 ⁽¹⁾		ns
J2	t _w (TCKH)	Pulse width minimum, TCK high	18.6 ⁽²⁾		ns
J3	t _w (TCKL)	Pulse width minimum, TCK low	18.6 ⁽²⁾		ns
J4	t _{su} (TDI-TCK)	Input setup time minimum, TDI valid to TCK high	4.5		ns
	t _{su} (TMS-TCK)	Input setup time minimum, TMS valid to TCK high	4.5		ns
J5	t _h (TCK-TDI)	Input hold time minimum, TDI valid from TCK high	2		ns
	t _h (TCK-TMS)	Input hold time minimum, TMS valid from TCK high	2		ns

- (1) The maximum TCK operating frequency assumes the following timing requirements and switching characteristics for the attached debugger. The operating frequency of TCK must be reduced to provide appropriate timing margin if the debugger exceeds any of these assumptions.
- Minimum TDO setup time of 4.6 ns relative to the rising edge of TCK
 - TDI and TMS output delay in the range of –16.5 ns to 14.0 ns relative to the falling edge of TCK
- (2) P = TCK cycle time in ns

6.10.6.2.1.2 JTAG Switching Characteristics

See [Figure 6-112](#)

NO.	PARAMETER		MIN	MAX	UNIT
J6	$t_{d(TCKL-TDOI)}$	Delay time minimum, TCK low to TDO invalid	0		ns
J7	$t_{d(TCKL-TDOV)}$	Delay time maximum, TCK low to TDO valid		12	ns

- The JTAG signals are split across two IO power domains on the device. Timings parameters defined in this table only apply when the two IO power domains are operating at the same voltage. Values for these timing parameters are not defined when operating the two IO power domains at different voltages since propagation delay through the device IO buffers differ when some are operating at 1.8V while others are operating at 3.3V. This effectively reduces timing margin beyond the values defined in this table. The JTAG interface is still expected to function when the two IO power domains are operated at different voltages, assuming the system designer has implemented appropriate level shifters and the operating frequency is reduced to accommodate additional delay inserted by the level-shifters and IO buffers operating at different voltages.

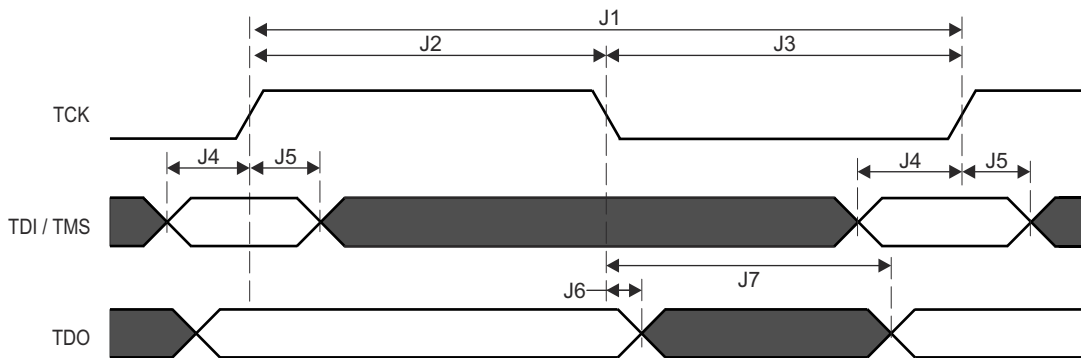

Figure 6-112. JTAG Timing Requirements and Switching Characteristics

7 Detailed Description

7.1 Overview

The AM69, AM69A processor family is based on the evolutionary Jacinto 7 architecture, targeted at ADAS and Autonomous Vehicle (AV) applications and built on extensive market knowledge accumulated over a decade of TI's leadership in the ADAS processor market. The AM69, AM69A provides high performance compute for both traditional and deep learning algorithms at industry leading power/performance ratios with a high level of system integration to enable scalability and lower costs for advanced automotive platforms supporting multiple sensor modalities in centralized ECUs or stand-alone sensors. Key cores include next generation DSP with scalar and vector cores, dedicated deep learning and traditional algorithm accelerators, latest Arm and GPU processors for general compute, an integrated next generation imaging subsystem (ISP), video codec, Ethernet hub and isolated MCU island. All protected by automotive grade safety and security hardware accelerators.

Note

For more information on features, subsystems, and architecture of superset device System on Chip (SoC), see the device TRM.

7.2 Functional Block Diagram

Figure 7-1 is functional block diagram for the device.

Note

To understand what device features are currently supported by TI Software Development Kits (SDKs), see the [AM69 Software Build Sheet \(PROCESSOR-SDK-AM69\)](#) and [AM69A Software Build Sheet \(PROCESSOR-SDK-AM69A\)](#).

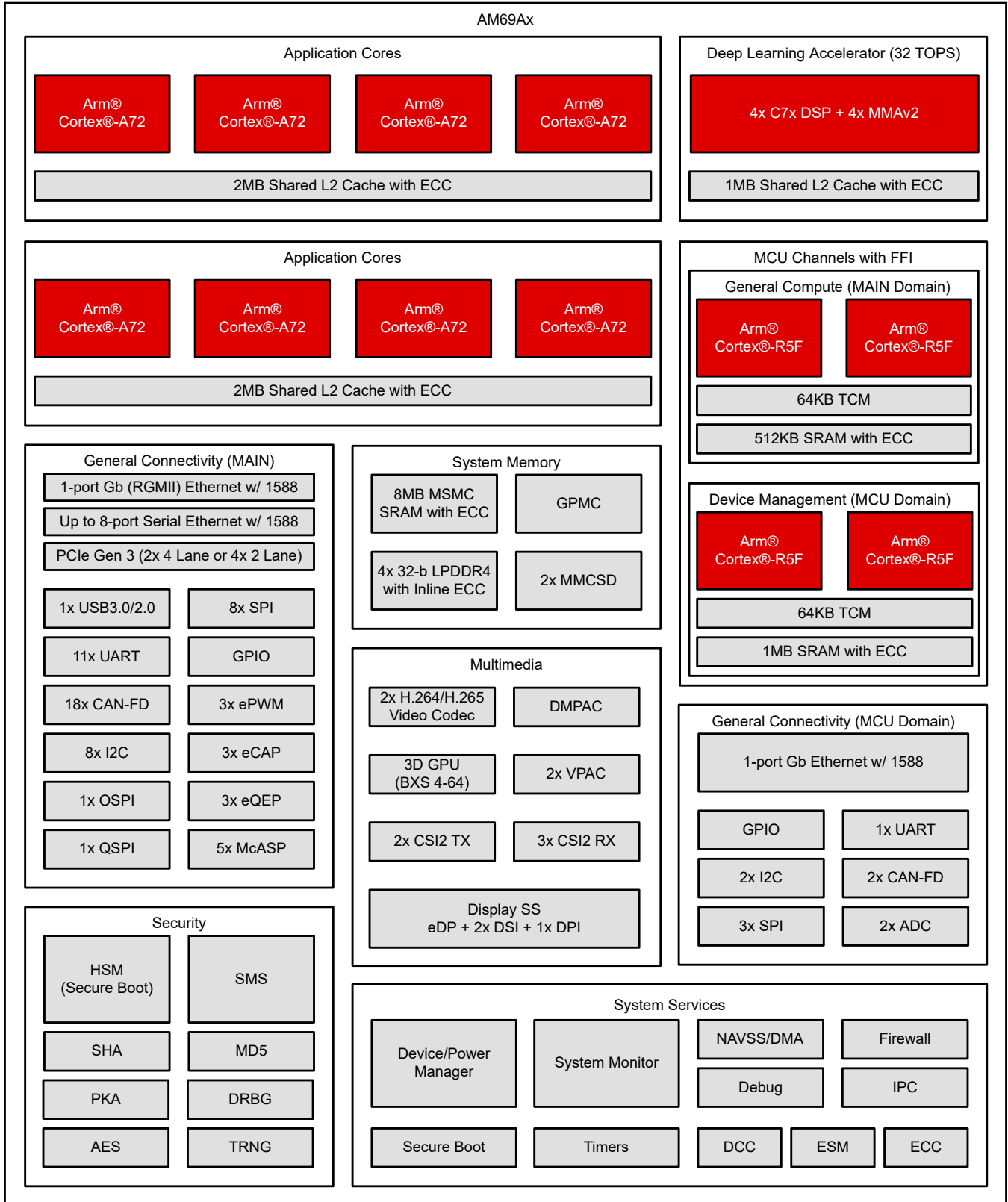

Figure 7-1. Functional Block Diagram

7.3 Processor Subsystems

7.3.1 Arm Cortex-A72

The device implements one dual-core Arm® Cortex®-A72 MPU, which is integrated inside the Compute Cluster, along with other modules. The Cortex-A72 cores are general-purpose processors that can be used for running customer applications.

The A72SS is built around the Arm Cortex-A72 MPCore (A72 cluster), which is provided by Arm and configured by TI. It is based on the symmetric multiprocessor (SMP) architecture, and thus it delivers high performance and optimal power management and debug capabilities.

The A72 processor is a multi-issue out-of-order superscalar execution engine with integrated L1 instruction and data caches, compatible with Armv8-A architecture. The Armv8-A architecture brings a number of new features. These include 64-bit data processing, extended virtual addressing and 64-bit general purpose registers.

For more information, see *Dual-A72 MPU Subsystem* section in *Processors and Accelerators* chapter in the device TRM.

7.3.2 Arm Cortex-R5F

The MCU_ARMSS is a dual-core implementation of the Arm® Cortex®-R5F processor configured for split/lock operation. It also includes accompanying memories (L1 caches and tightly-coupled memories), standard Arm® CoreSight™ debug and trace architecture, integrated Vectored Interrupt Manager (VIM), ECC Aggregators, and various wrappers for protocol conversion and address translation for easy integration into the SoC.

For more information, see *Dual-R5F MCU Subsystem* section in *Processors and Accelerators* chapter in the device TRM.

7.3.3 DSP C71x

The TMS320C71x is the next-generation fixed and floating-point DSP platform. The C71x DSP is a new core in the Texas Instruments' DSP family. The C71x DSP supports vector signal processing, providing significant lift in DSP processing power over a broad range of general signal processing tasks in comparison to the C6x DSP family. In addition, the C71x provides several specialized functions which accelerate targeted functions by more than 30 times. Besides expanding vector processing capabilities, the new C71x core also incorporates advanced techniques to improve control code efficiency and ease of programming such as branch prediction, protected pipeline, precise exception and virtual memory management.

For more information, see *C71x DSP Subsystem* section in *Processors and Accelerators* chapter in the device TRM.

7.4 Accelerators and Coprocessors

7.4.1 GPU

The Graphics Processing Unit (GPU) accelerates 3-dimensional (3D) and 2-dimensional (2D) graphics and compute applications.

The GPU module is a scalable architecture which efficiently processes a number of different workload concurrently:

- 3D Graphic Workload, which involves vertex data and pixel data processing for rendering of 3D scenes.
- 2D Graphic Workload, which involves pixel data processing for rendering 2D objects.
- Compute Applications Workload, which involves general purpose data processing.

For more information, see *Graphics Accelerator (GPU)* section in *Processors and Accelerators* chapter in the device TRM.

7.4.2 VPAC

The Vision Pre-processing Accelerator (VPAC) is a set of common vision primitive functions, performing memory-to-memory (M2M) pixel data processing tasks, such as: color processing and enhancement, noise filtering, wide dynamic range (WDR) processing, lens distortion correction, pixel remap for dewarping, on-the-fly scale generation, on-the-fly pyramid generation. The VPAC offloads these common tasks from the main SoC processors (ARM, DSP, etc.), so these CPUs can be utilized for differentiated high-level algorithms. The VPAC is designed to support multiple cameras by working in time-multiplexing mode. The VPAC works as front end to vision processing and prepares frame/scales for further processing by other vision accelerators or processor cores in the SoC.

For more information, see *Vision Pre-processing Accelerator (VPAC)* section in *Processors and Accelerators* chapter in the device TRM.

7.4.3 DMPAC

The Depth and Motion Perception Accelerator (DMPAC) is a power efficient hardware accelerator that computes dense stereo depth maps (*depth*) and dense optical flow vectors (*motion*) from camera inputs.

The image/video sensor-based environmental perception (also known as scene understanding) is at the core of many emerging applications in automotive, industrial and consumer electronics. Typically, this involves detection of all objects in the scene along with their 3D position and motion with regards to the observer or the car by analyzing one or many related input video streams. Various computer vision algorithms are used to achieve these tasks.

A very robust method of obtaining the 3D depth from images is to use two cameras in a stereo setup - two cameras with known relative positions and camera parameters. The two images of the same scene, captured from two different camera poses/perspectives, are analyzed to find disparities among every pixel positions in the images. This is known as the Stereo Disparity map. The disparity values of every pixel can be used to obtain the 3D positions of the object/space they belong to via triangulation.

On the other hand, by analyzing two images from a single camera, captured at two different time instances (that is, two temporal frames in a video), one can determine where each pixel in a past frame moved to in the future frame. This is known as the Optical Flow vector. The flow vectors for each pixel position can be used to obtain 3D structure of the scene, identify moving objects and determine their relative speed and direction of motion.

The DMPAC is dedicated to the aforesaid image processing tasks. The stereo and optical flow processing is partitioned into two top level sub-blocks: the Dense Optical Flow (DOF) engine and the Stereo Disparity Engine (SDE). The DOF and SDE blocks share a common shared local memory, DMA, external messaging and control infrastructure.

For more information, see *Depth and Motion Perception Accelerator (DMPAC)* section in *Processors and Accelerators* chapter in the device TRM.

7.5 Other Subsystems

7.5.1 MSMC

The Multicore Shared Memory Controller (MSMC) forms the heart of the compute cluster (COMPUTE_CLUSTER0) providing high-bandwidth resource access both to and from all of the connected processing elements and the rest of the system. MSMC serves as the data-movement backbone of the compute cluster.

For more information, see *Multicore Shared Memory Controller (MSMC)* section in *Device Configuration* chapter in the device TRM.

7.5.2 NAVSS

7.5.2.1 NAVSS0

Main SoC Navigator Subsystem (NAVSS0) consists of DMA/Queue Management components – UDMA and Ring Accelerator (UDMASS), Peripherals (Module subsystem [MODSS]), Virtualization translation (VirtSS), and a North Bridge (NBSS).

7.5.2.2 MCU_NAVSS

MCU Navigator Subsystem (MCU NAVSS) has a subset of the modules of the main NAVSS and is instantiated in the MCU domain.

MCU Navigator Subsystem consists of DMA/Queue Management components – UDMA and Ring Accelerator (UDMASS), and Peripherals (Module subsystem [MODSS]).

For more information, see *Main Navigator Subsystem (NAVSS)* and *MCU Navigator Subsystem (MCU NAVSS)* sections in the device TRM.

7.5.3 PDMA Controller

The Peripheral DMA is a simple DMA which has been architected to specifically meet the data transfer needs of peripherals, which perform data transfers using memory mapped registers accessed via a standard non-coherent bus fabric. The PDMA module is intended to be located close to one or more peripherals which require an external DMA for data movement and is architected to reduce cost by using VBUSP interfaces and supporting only statically configured Transfer Request (TR) operations.

The PDMA is only responsible for performing the data movement transactions which interact with the peripherals themselves. Data which is read from a given peripheral is packed by a PDMA source channel into a PSI-L data stream which is then sent to a remote peer UDMA-P destination channel which then performs the movement of the data into memory. Likewise, a remote UDMA-P source channel fetches data from memory and transfers it to a peer PDMA destination channel over PSI-L which then performs the writes to the peripheral.

The PDMA architecture is intentionally heterogeneous (UDMA-P + PDMA) to right size the data transfer complexity at each point in the system to match the requirements of whatever is being transferred to or from. Peripherals are typically FIFO based and do not require multi-dimensional transfers beyond their FIFO dimensioning requirements, so the PDMA transfer engines are kept simple with only a few dimensions (typically for sample size and FIFO depth), hardcoded address maps, and simple triggering capabilities.

Multiple source and destination channels are provided within the PDMA which allow multiple simultaneous transfer operations to be ongoing. The DMA controller maintains state information for each of the channels and employs round-robin scheduling between channels in order to share the underlying DMA hardware.

For more information, see *PDMA Controller* section in *DMA Controllers* chapter in the device TRM.

7.5.4 Power Supply

The device requires 6 power supply types and 1 internal LDO connection type, see [Power Supply Signal Descriptions](#)

- Digital IO Voltages
- Digital Low Voltages
- Digital AVS Voltage

- Analog PHY & CLK Voltages
- Analog Low Voltages
- Efuse Programming Voltages
- LDO Bulk Filter Capacitors

Common device power supply input types can be grouped together into power rails. All power rails must be supplied by power resources designed to support the most stringent power supply voltage specification and total load current demands. Two recommended Power Distribution Networks (PDNs) have been defined that either combine or isolate MCU and Main domains, (refer to *Power Supply Mapping*).

It is possible that a few power supply inputs may not be needed in some systems. In such cases, all unused supply inputs, other than VPP_CORE & VPP_MCU, must be connected to a valid power rail with a proper voltage level in order to ensure device reliability (refer to [Recommended Operating Conditions](#)). The following examples are given for reference:

1. If MCU Island safety monitor or MCU Only low power processing are not used, then VDD_MCU supply can be combined with the VDD_CORE supply with compatible operating voltage specification.
2. If UHS-I SD Card or USB2.0 interface is not needed, then VDDSHV5 (MMC1 interface) and VDDA_USB_3P3 (USB PHY interface) can be combined with VDD_IO_3V3 digital IO power rail.
3. If General Purpose device type is used, then Efuse programming voltages VPP_CORE & VPP_MCU are not needed and should be left unconnected.

7.5.5 Peripherals

7.5.5.1 ADC

The Analog-to-Digital Converter (ADC) module contains a single 12-bit ADC which can be multiplexed to any 1 of 8 analog inputs (channels).

For more information, see *Analog-to-Digital Converter (ADC)* section in *Peripherals* chapter in the device TRM.

7.5.5.2 ATL

The Audio Tracking Logic (ATL) is used by HD Radio™ applications to synchronize the digital audio output to the baseband clock. This same IP can also be used generically to track errors between two reference signals (such as frame syncs) and generate a modulated clock output (using software-controlled cycle stealing) which averages to some desired frequency. This process can be used as a hardware assist for asynchronous sample rate conversion algorithms.

For more information, see *Audio Tracking Logic (ATL)* section in *Peripherals* chapter in the device TRM.

7.5.5.3 CSI

7.5.5.3.1 Camera Streaming Interface Receiver (CSI_RX_IF) and MIPI DPHY Receiver (DPHY_RX)

The integration of the CSI_RX_IF module allows the device to stream video inputs from multiple cameras to the image processing accelerator (VPAC) or to internal memory. The video input may also be retransmitted via the transmitter CSI (CSI_TX_IF) for debug and test purposes.

For more information, see *Camera Streaming Interface (CSI)* section in *Peripherals* chapter in the device TRM.

7.5.5.3.2 Camera Streaming Interface Transmitter (CSI_TX_IF)

The integration of the CSI_TX_IF module allows the device to stream out video data from memory, or retransmit from the CSI receivers as an optional loopback output for diagnostics, debug, and test purposes.

For more information, see *Camera Streaming Interface (CSI)* section in *Peripherals* chapter in the device TRM.

7.5.5.4 CPSW2G

The two-port Gigabit Ethernet MAC (MCU_CPSW0) subsystem provides Ethernet packet communication for the device and is configured in a similar manner as an Ethernet switch. MCU_CPSW0 features the Reduced Gigabit Media Independent Interface (RGMII), Reduced Media Independent Interface (RMII), and the Management Data Input/Output (MDIO) interface for physical layer device (PHY) management.

For more information, see *Gigabit Ethernet Switch (CPSW0)* section in *Peripherals* chapter in the device TRM.

7.5.5.5 CPSW9G

The 9-port Gigabit Ethernet Switch (CPSW0) subsystem provides Ethernet packet communication for the device and can be configured as an Ethernet switch. CPSW0 features the Serial Gigabit Media Independent Interface (SGMII), Reduced Gigabit Media Independent Interface (RGMII), Reduced Media Independent Interface (RMII) and the Management Data Input/Output (MDIO) interface for physical layer device (PHY) management.

For more information, see *Gigabit Ethernet Switch (MCU_CPSW0)* section in *Peripherals* chapter in the device TRM.

7.5.5.6 DCC

The Dual Clock Comparator (DCC) is used to determine the accuracy of a clock signal during the time execution of an application. Specifically, the DCC is designed to detect drifts from the expected clock frequency. The desired accuracy can be programmed based on calculation for each application. The DCC measures the frequency of a selectable clock source using another input clock as a reference.

For more information, see *Dual Clock Comparator (DCC)* section in *Peripherals* chapter in the device TRM.

7.5.5.7 DDRSS

The DDR subsystem in this device comprises DDR controller, DDR PHY and wrapper logic to integrate these blocks in the device. The DDR subsystem is referred to as DDRSS0 and is used to provide an interface to external SDRAM devices which can be utilized for storing program or data. DDRSS0 is accessed via MSMC, and not directly through the system interconnect.

For more information, see *DDR Subsystem (DDRSS)* section in *Peripherals* chapter in the device TRM.

7.5.5.8 DSS

The DSS is a flexible composition-enabled display subsystem, that supports multiple high resolution display outputs. It consists of one Display Controller (DISPC) and one Frame Buffer Decompression Core (FBDC). The DISPC supports a multi-layer blending and transparency for each of its display outputs. The DISPC also supports a write-back pipeline with scaling to enable memory-to-memory composition and/or to capture a display output for Ethernet video encoding.

For more information, see *Display Subsystem (DSS)* section in *Peripherals* chapter in the device TRM.

7.5.5.8.1 DSI

The MIPI DSI v1.3.1 Controller (DSITX) implements the stream arbitration and low-level protocol layer functionalities required by MIPI DSI 1.3 standard. It supports up to 4 x 2.5 Gbps D-PHY data lanes in a single-link configuration and handles the byte lane mapping per use case (1, 2, 3, or 4-lanes). The accompanying DSI (Physical Layer) D-PHY module (DPHYTX) provides the video output interfacing by implementing a four-lane MIPI D-PHY transmitter.

For more information, see *Display Subsystem (DSS) and Display Peripherals* section in *Peripherals* chapter in the device TRM.

7.5.5.8.2 eDP

The VESA DP1.4/eDP1.4 Compliant Transmitter Host Controller (EDP) can output up to 4 video streams (through Multiple Stream Transport / MST) and one audio stream through the 4-lane accompanying SerDes module. It provides up to 25.92 Gbps of application bandwidth. An additional eDP (Physical Layer) auxiliary PHY (AUXPHY) module implements a doubly-terminated differential pair required for 1 Mbps data rates over a long (15m) cable.

For more information, see *Display Subsystem (DSS) and Display Peripherals* section in *Peripherals* chapter in the device TRM.

7.5.5.9 eCAP

The enhanced Capture (ECAP) module can be used for:

- Sample rate measurements of audio inputs

- Speed measurements of rotating machinery (for example, toothed sprockets sensed via Hall sensors)
- Elapsed time measurements between position sensor pulses
- Period and duty cycle measurements of pulse train signals
- Decoding current or voltage amplitude derived from duty cycle encoded current/voltage sensors.

For more information, see *Enhanced Capture (ECAP) Module* section in *Peripherals* chapter in the device TRM.

7.5.5.10 EPWM

An effective PWM peripheral must be able to generate complex pulse width waveforms with minimal CPU overhead or intervention. It needs to be highly programmable and very flexible while being easy to understand and use. The EPWM unit described here addresses these requirements by allocating all needed timing and control resources on a per PWM channel basis. Cross coupling or sharing of resources has been avoided; instead, the EPWM is built up from smaller single channel modules with separate resources and that can operate together as required to form a system. This modular approach results in an orthogonal architecture and provides a more transparent view of the peripheral structure, helping users to understand its operation quickly.

In the further description the letter x within a signal or module name is used to indicate a generic EPWM instance on a device. For example, output signals EPWMxA and EPWMxB refer to the output signals from the EPWM_x instance. Thus, EPWM1A and EPWM1B belong to EPWM1, EPWM2A and EPWM2B belong to EPWM2, and so forth.

Additionally, the EPWM integration allows this synchronization scheme to be extended to the capture peripheral modules (ECAP). The number of modules is device-dependent and based on target application needs. Modules can also operate stand-alone.

For more information, see *Enhanced Pulse Width Modulation (EPWM) Module* section in *Peripherals* chapter in the device TRM.

7.5.5.11 ELM

The Error Location Module (ELM) is used with the GPMC. Syndrome polynomials generated on-the-fly when reading a NAND flash page and stored in GPMC registers are passed to the ELM. A host processor can then correct the data block by flipping the bits to which the ELM error-location outputs point.

When reading from NAND flash memories, some level of error-correction is required. In the case of NAND modules with no internal correction capability, sometimes referred to as *bare NANDs*, the correction process is delegated to the memory controller. ELM can be also used to support parallel NOR flash or NAND flash.

For more information, see *Error Location Module (ELM)* section in *Peripherals* chapter in the device TRM.

7.5.5.12 ESM

The Error Signaling Module (ESM) aggregates safety-related events and/or errors from throughout the device into one location. It can signal both low and high priority interrupts to a processor to deal with a safety event and/or manipulate an I/O error pin to signal an external hardware that an error has occurred. Therefore an external controller is able to reset the device or keep the system in safe, known state.

For more information, see *Error Signaling Module (ESM)* section in *Peripherals* chapter in the device TRM.

7.5.5.13 eQEP

The Enhanced Quadrature Encoder Pulse (EQEP) peripheral is used for direct interface with a linear or rotary incremental encoder to get position, direction and speed information from a rotating machine for use in high performance motion and position control system. The disk of an incremental encoder is patterned with a single track of slots patterns. These slots create an alternating pattern of dark and light lines. The disk count is defined as the number of dark/light line pairs that occur per revolution (lines per revolution). As a rule, a second track is added to generate a signal that occurs once per revolution (index signal: QEPI), which can be used to indicate an absolute position. Encoder manufacturers identify the index pulse using different terms such as index, marker, home position and zero reference.

For more information, see *Enhanced Quadrature Encoder Pulse (EQEP) Module* section in *Peripherals* chapter in the device TRM.

7.5.5.14 GPIO

The General-Purpose Input/Output (GPIO) peripheral provides dedicated general-purpose pins that can be configured as either inputs or outputs. When configured as an output, the user can write to an internal register to control the state driven on the output pin. When configured as an input, user can obtain the state of the input by reading the state of an internal register.

In addition, the GPIO peripheral can produce host CPU interrupts and DMA synchronization events in different interrupt/event generation modes.

For more information, see *General-Purpose Interface (GPIO)* section in *Peripherals* chapter in the device TRM.

7.5.5.15 GPMC

The General-Purpose Memory Controller is a unified memory controller dedicated for interfacing with external memory devices like:

- Asynchronous SRAM-like memories and application-specific integrated circuit (ASIC) devices
- Asynchronous, synchronous, and page mode (available only in non-multiplexed mode) burst NOR flash devices
- NAND flash
- Pseudo-SRAM devices

For more information, see *General-Purpose Memory Controller (GPMC)* section in *Peripherals* chapter in the device TRM.

7.5.5.16 Hyperbus

The Hyperbus module is a part of the device Flash Subsystem (FSS).

The Hyperbus module is low pin count memory interface that provides high read/write performance. The Hyperbus module connects to hyperbus memory (HyperFlash or HyperRAM) and uses simple hyperbus protocol for read and write transactions.

There is one Hyperbus™ module inside the device. The Hyperbus module includes one Hyperbus Memory Controller (HBMC).

For more information, see *Hyperbus Interface* section in *Peripherals* chapter in the device TRM.

7.5.5.17 I2C

The device contains ten multimaster Inter-Integrated Circuit (I2C) controllers each of which provides an interface between a local host (LH), such as an Arm or a Digital Signal Processor (DSP), and any I²C-bus-compatible device that connects via the I²C serial bus. External components attached to the I²C bus can serially transmit and receive up to 8 bits of data to and from the LH device through the 2-wire I²C interface.

Each multimaster I2C module can be configured to act like a slave or master I²C-compatible device.

The WKUP_I2C0, MCU_I2C0, I2C0, and I2C1 controllers have dedicated I²C compliant open drain buffers, and support high speed mode (up to 3.4 Mbps in 1.8 V mode and up to 400 kbps in 3.3 V mode). The MCU_I2C1, I2C2, I2C3, I2C4, I2C5, and I2C6 controllers are multiplexed with standard LVCMOS I/O, connected to emulate open drain, and support fast mode (up to 400 kbps in 1.8 V/3.3 V mode). The I2C emulation is achieved by configuring the LVCMOS buffers to output Hi-Z instead of driving high when transmitting logic 1.

For more information, see *Inter-Integrated Circuit (I2C) Interface* section in *Peripherals* chapter in the device TRM.

7.5.5.18 I3C

The device contains three Improved Inter-Integrated Circuit (I3C) controllers each of which provides an interface between a local host (LH), such as an Arm, and any I3C-bus-compatible device that connects via the I3C serial bus.

For more information, see *Improved Inter-Integrated Circuit (I3C) Interface* section in *Peripherals* chapter in the device TRM.

7.5.5.19 MCAN

The Controller Area Network (CAN) is a serial communications protocol which efficiently supports distributed real-time control. CAN has high immunity to electrical interference. In a CAN network, many short messages are broadcast to the entire network, which provides for data consistency in every node of the system.

The MCAN module supports both classic CAN and CAN FD (CAN with Flexible Data-Rate) specifications. CAN FD feature allows high throughput and increased payload per data frame. The classic CAN and CAN FD devices can coexist on the same network without any conflict.

For more information, see *Modular Controller Area Network (MCAN)* section in *Peripherals* chapter in the device TRM.

7.5.5.20 MCASP

The MCASP functions as a general-purpose audio serial port are optimized to the requirements of various audio applications. The MCASP module can operate in both transmit and receive modes. The MCASP is useful for time-division multiplexed (TDM) stream, Inter-IC Sound (I2S) protocols reception and transmission as well as for an inter-component digital audio interface transmission (DIT). The MCASP has the flexibility to gluelessly connect to a Sony/Philips digital interface (S/PDIF) transmit physical layer component.

Although inter-component digital audio interface reception (DIR) mode (this is, S/PDIF stream receiving) is not natively supported by the MCASP module, a specific TDM mode implementation for the MCASP receivers allows an easy connection to external DIR components (for example, S/PDIF to I2S format converters).

For more information, see *Multichannel Audio Serial Port (MCASP)* section in *Peripherals* chapter in the device TRM.

7.5.5.21 MCRC Controller

VBUSM CRC controller is a module which is used to perform CRC (Cyclic Redundancy Check) to verify the integrity of a memory system. A signature representing the contents of the memory is obtained when the contents of the memory are read into MCRC Controller. The responsibility of MCRC controller is to calculate the signature for a set of data and then compare the calculated signature value against a predetermined good signature value. MCRC controller provides four channels to perform CRC calculation on multiple memories in parallel and can be used on any memory system. Channel 1 can also be put into data trace mode, where MCRC controller compresses each data being read through CPU read data bus.

For more information, see *MCRC Controller* section in *Interprocessor Communication* chapter in the device TRM.

7.5.5.22 MCSPI

The MCSPI module is a multichannel transmit/receive, master/slave synchronous serial bus.

There are total of eleven MCSPI modules in the device.

For more information, see *Multichannel Serial Peripheral Interface (MCSPI)* section in *Peripherals* chapter in the device TRM.

7.5.5.23 MMC/SD

The MMCS Host Controller provides an interface to eMMC 5.1 (embedded MultiMedia Card), SD 4.10 (Secure Digital), and SDIO 4.0 (Secure Digital IO) devices. The MMCS Host Controller deals with MMC/SD/SDIO protocol at transmission level, data packing, adding cyclic redundancy checks (CRCs), start/end bit insertion, and checking for syntactical correctness.

For more information, see *Multimedia Card/Secure Digital (MMC/SD) Interface* section in *Peripherals* chapter in the device TRM.

7.5.5.24 OSPI

The Octal Serial Peripheral Interface (OSPI) module is a kind of Serial Peripheral Interface (SPI) module which allows single, dual, quad or octal read and write access to external flash devices. This module has a memory mapped register interface, which provides a direct memory interface for accessing data from external flash devices, simplifying software requirements.

The OSPI module is used to transfer data, either in a memory mapped direct mode (for example a processor wishing to execute code directly from external flash memory), or in an indirect mode where the module is set-up to silently perform some requested operation, signalling its completion via interrupts or status registers. For indirect operations, data is transferred between system memory and external flash memory via an internal SRAM which is loaded for writes and unloaded for reads by a device master at low latency system speeds. Interrupts or status registers are used to identify the specific times at which this SRAM should be accessed using user programmable configuration registers.

For more information, see *Octal Serial Peripheral Interface (OSPI)* section in *Peripherals* chapter in the device TRM.

7.5.5.25 PCIE

The Peripheral Component Interconnect Express (PCIe) subsystem is built around a multi-lane dual-mode PCIe controller that provides low pin-count, high reliability, and high-speed data transfers at rates of up to 8.0 Gbps per lane for serial links on backplanes and printed wiring boards.

For more information, see *Peripheral Component Interconnect Express (PCIe) Subsystem* section in *Peripherals* chapter in the device TRM.

7.5.5.26 SerDes

SerDes'es goal is to convert device (SoC) parallel data into serialized data that can be output over a highspeed electrical interface. In the opposite direction, SerDes converts high-speed serial data into parallel data that can be processed by the device. To this end, the SerDes contains a variety of functional blocks to handle both the external analog interface as well as the internal digital logic.

For more information, see *Serializer/Deserializer (SerDes)* section in *Peripherals* chapter in the device TRM.

7.5.5.27 WWDT

The Windowed Watchdog Timer provides timer functionality for operating systems and for benchmarking code. The module incorporates several counters, which define the timebases needed for scheduling in the operating system. The module is implemented with an RTI module, but only WWDT is supported.

This module is specifically designed to fulfill the requirements for OSEK ("Offene Systeme und deren Schnittstellen für die Elektronik im Kraftfahrzeug"; "Open Systems and the Corresponding Interfaces for Automotive Electronics") as well as OSEK/Time compliant operating systems.

For more information, see *Real Time Interrupt (RTI) Module* section in *Peripherals* chapter in the device TRM.

7.5.5.28 Timers

All timers include specific functions to generate accurate tick interrupts to the operating system.

Each timer can be clocked from several different independent clocks. The selection of clock source is made from registers in the MCU_CTRL_MMR0/CTRL_MMR0.

In the MCU domain the device provides 10 timer pins to be used as MCU Timer Capture inputs or as MCU Timer PWM outputs. In order to provide maximum flexibility, these 10 pins may be used with any of MCU_TIMER0 through MCU_TIMER9 instances. System level muxes are used to control the capture source pin for each MCU_TIMER[9-0] and the MCU_TIMER[9-0] source for each MCU_TIMER_IO[1-0] PWM output.

In the MAIN domain the device provides 8 timer pins to be used as Timer Capture inputs or as Timer PWM outputs. For maximum flexibility, these 8 pins may be used with any of TIMER0 through TIMER19 instances. System level muxes are used to control the capture source pin for each TIMER[19-0] and the TIMER[19-0] source for each TIMER_IO[7-0] PWM output.

Each odd numbered timer instance from each of the domains may be optionally cascaded with the previous even numbered timer instance from the same domain to form up to a 64-bit timer. For example, TIMER1 may be cascaded to TIMER0, MCU_TIMER1 may be cascaded to MCU_TIMER0, etc.

When cascaded, TIMER_i acts as a 32-bit prescaler to TIMER_{i+1}, as well as MCU_TIMER_n acts as a 32-bit prescaler to MCU_TIMER_{n+1}. TIMER_i / MCU_TIMER_n must be configured to generate a PWM output edge at the desired rate to increment the TIMER_{i+1} / MCU_TIMER_{n+1} counter.

For more information, see *Timers* section in *Peripherals* chapter in the device TRM.

7.5.5.29 UART

The UART is a slave peripheral that utilizes the DMA for data transfer or interrupt polling via host CPU. There are twelve UART modules in the device. All UART modules support IrDA and CIR modes when 48 MHz function clock is used. Each UART can be used for configuration and data exchange with a number of external peripheral devices or interprocessor communication between devices.

For more information, see *Universal Synchronous/Asynchronous Receiver/Transmitter (UART)* section in *Peripherals* chapter in the device TRM.

7.5.5.30 USB

Similar to earlier versions of USB bus, USB 3.0 is a general-purpose cable bus, supporting data exchange between a host device and a wide range of simultaneously accessible peripherals.

The device supports two identical USB subsystems:

- USB3SS0 is SuperSpeed (SS) USB 3.0 Dual-Role-Device (DRD) subsystem with on-chip SS (USB3.0) PHY and HS/FS/LS (1) (USB2.0) PHY
- USB3SS1 is SuperSpeed (SS) USB 3.0 Dual-Role-Device (DRD) subsystem with on-chip SS (USB3.0) PHY and HS/FS/LS (USB2.0) PHY

For more information, see *Universal Serial Bus (USB) Subsystem* section in *Peripherals* chapter in the device TRM.

7.5.5.31 UFS

The Universal Flash Storage (UFS) interface is a standard-based serial interface engine.

There is one UFS module inside the device - UFS0. The UFS module includes one UFS 2.1 host controller (HC) with an integrated M-PHY.

The UFS module complies with the standards as listed in [Table 7-1](#).

Table 7-1. UFS Standards

DOCUMENT	VERSION	DESCRIPTION
JESD220-1A	v1.1	Universal Flash Storage (UFS) Unified Memory Extension
JESD220-2	v1.0	Universal Flash Storage (UFS) Card Extension
JESD220C	v2.1, March 2016	Universal Flash Storage (UFS)
JESD223-1B	v1.1A	Universal Flash Storage Host Controller Interface (UFSHCI) Unified Memory Extension
JESD223C	v2.1, March 2016	Universal Flash Storage Host Controller Interface (UFSHCI)
JESD224	March 2013	Universal Flash Storage (UFS) Test
	November, 2001	Federal Information Processing Standards (FIPS) 197 Advanced Encryption Standard (AES)
	v3.1, 2014	MIPI® Alliance Specification for M-PHY
	v1.60, 2013	MIPI Alliance Specification for Unified Protocol (UniProSM)
	Revision 24, August 2010	Small Computer System Interface (SCSI) Block Commands - 3
	Revision 27, October 2010	SCSI Primary Commands - 4

For more information, see *Universal Flash Storage (UFS) Interface* section in *Peripherals* chapter in the device TRM.

8 Applications, Implementation, and Layout

Note

Information in the following applications sections is not part of the TI component specification, and TI does not warrant its accuracy or completeness. TI's customers are responsible for determining suitability of components for their purposes. Customers should validate and test design implementation to confirm system functionality.

9 Device Connection and Layout Fundamentals

9.1 Power Supply Decoupling and Bulk Capacitors

9.1.1 Power Distribution Network Implementation Guidance

The [Powering Jacinto™ J7 SoC Family For Isolated Power Groups With TPS6594133A-Q1 PMIC and Dual HCPS Converters](#) User's Guide provides guidance for successful implementation of the power distribution network. This includes PCB stackup guidance as well as guidance for optimizing the selection and placement of the decoupling capacitors. TI supports *only* designs that follow the board design guidelines contained in the application report.

9.2 External Oscillator

For more information about External Oscillators, see [Clock Specifications](#).

9.3 JTAG and EMU

Texas Instruments supports a variety of eXtended Development System (XDS) JTAG controllers with various debug capabilities beyond only JTAG support. A summary of this information is available in the [XDS Target Connection Guide](#).

For more recommendations on EMU routing, see [Emulation and Trace Headers Technical Reference Manual](#)

9.4 Reset

The device incorporates four external reset pins (MCU_PORz, MCU_RESETz, PORz, and RESET_REQz) and two reset status pins (MCU_RESETSTATz and RESETSTATz). These pins can be driven by an external power good circuitry or Power Management IC (PMIC). MCU_PORz and Main PORz pins should be held active low during the entire power-up phase, and until all power supplies as well as the HFOSC0 clock are stable.

All MCU domain resets act as master resets to the whole device, whereas Main domain resets only reset Main domain (MCU domain is reset isolated from all Main domain resets).

9.5 Unused Pins

For more information about Unused Pins, see [Pin Connectivity Requirements](#).

9.6 Hardware Design Guide for Jacinto™ 7 Devices

The Hardware Design Guide for Jacinto™ 7 Devices document describes hardware system design considerations for the Jacinto™ 7 family of processors. This design guide is intended to be used as an aid during the development of application hardware.

10 Peripheral- and Interface-Specific Design Information

10.1 LPDDR4 Board Design and Layout Guidelines

The goal of the [Jacinto 7 DDR Board Design and Layout Guidelines](#) is to make the LPDDR4 system implementation straightforward for all designers. Requirements have been distilled down to a set of layout and routing rules that allow designers to successfully implement a robust design for the topologies that TI supports. TI only supports board designs using LPDDR4 memories that follow the guidelines in this document.

10.2 OSPI and QSPI Board Design and Layout Guidelines

The following section details the routing guidelines that must be observed when routing the OSPI and QSPI interfaces.

10.2.1 No Loopback and Internal Pad Loopback

- The MCU_OSPI[x]_CLK output signal must be connected to the CLK pin of the flash device
- The signal propagation delay from the MCU_OSPI[x]_CLK signal to the flash device must be < 450 ps (~7cm as stripline or ~8cm as microstrip)
- 50 Ω PCB routing is recommended along with series terminations, as shown in [Figure 10-1](#)
- Propagation delays and matching:
 - A to B < 450 ps
 - Matching skew: < 60 ps

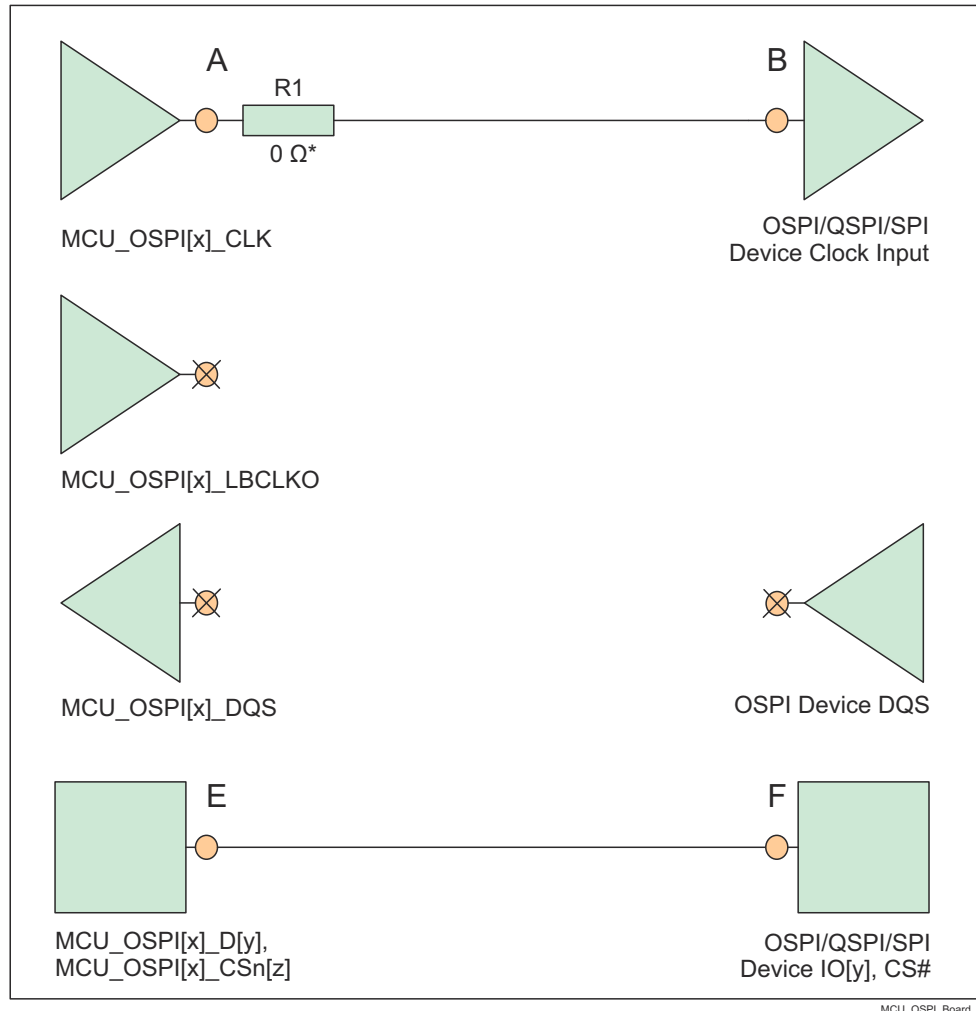

* 0 Ω resistor (R1), located as close as possible to the MCU_OSPI[x]_CLK pin, is placeholder for fine tuning, if needed.

Figure 10-1. OSPI Interface High Level Schematic

10.2.2 External Board Loopback

- The MCU_OSPI[x]_CLK output signal must be connected to the CLK pin of the flash device
- The MCU_OSPI[x]_LBCLKO output signal must be looped back into the MCU_OSPI[x]_DQS input
- The signal propagation delay from the MCU_OSPI[x]_CLK pin to the flash device CLK input pin (A to B) should be approximately equal to half of the signal propagation delay from the MCU_OSPI[x]_LBCLKO pin to the MCU_OSPI[x]_DQS pin ((C to D)/2). See the note below.
- The signal propagation delay from the MCU_OSPI[x]_CLK pin to the flash device CLK input pin (A to B) must be approximately equal to the signal propagation delay of the control and data signals between the flash device and the SoC device (E to F, or F to E)
- 50 Ω PCB routing is recommended along with series terminations, as shown in [Figure 10-2](#)
- Propagation delays and matching:
 - A to B = E to F = (C to D) / 2
 - Matching skew: < 60 ps

Note

The OSPI Board Loopback Hold time requirement (described in OSPI) is larger than the Hold time provided by a typical flash device. Therefore, the length of MCU_OSPI[x]_LBCLKO pin to the MCU_OSPI[x]_DQS pin (C to D) can be shortened to compensate.

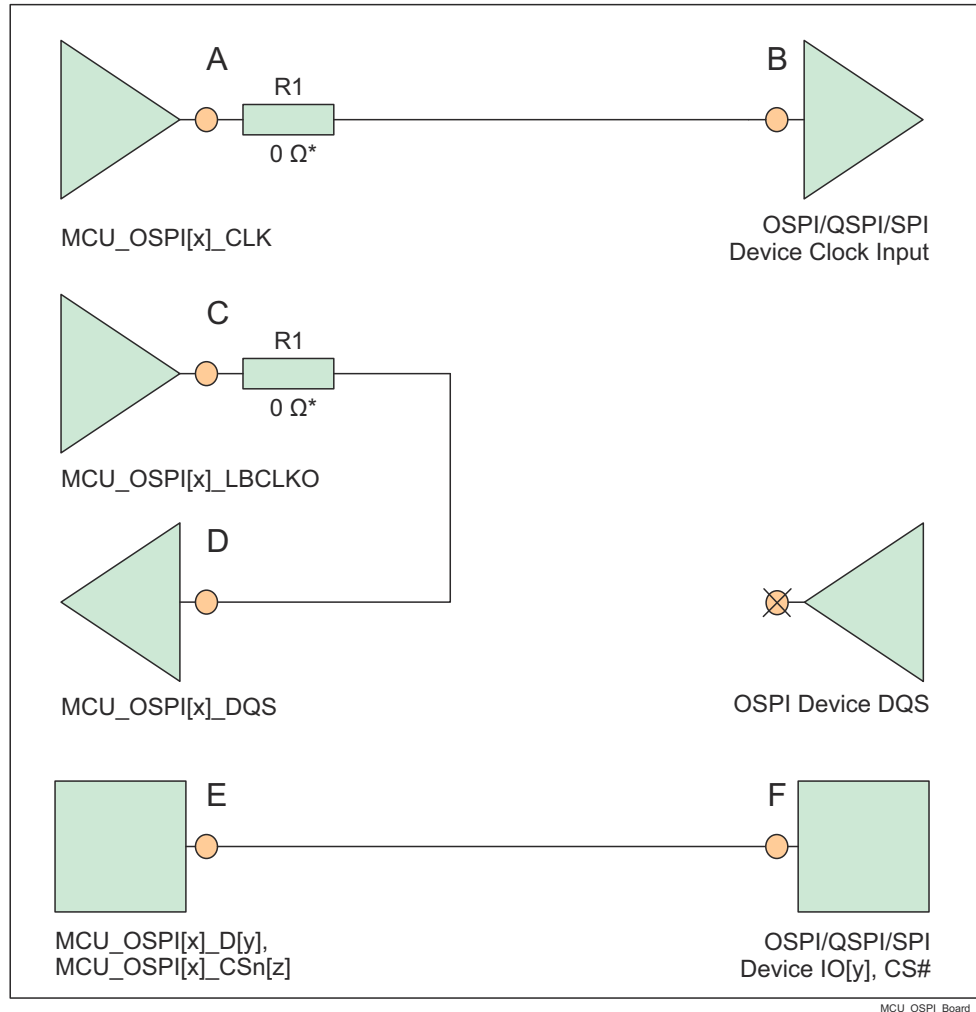

* 0 Ω resistor (R1), located as close as possible to the MCU_OSPI[x]_CLK and MCU_OSPI[x]_LBCLKO pins, is a placeholder for fine tuning, if needed.

Figure 10-2. OSPI Interface High Level Schematic

10.2.3 DQS (only available in Octal Flash devices)

- The MCU_OSPI[x]_CLK output signal must be connected to the CLK pin of the flash device
- The DQS pin of the flash devices must be connected to MCU_OSPI[x]_DQS signal
- The signal propagation delay from the MCU_OSPI[x]_CLK pin to the flash device CLK input pin (A to B) should be approximately equal to the signal propagation delay from the MCU_OSPI[x]_DQS pin to the DQS output pin (C to D)
- 50 Ω PCB routing is recommended along with series terminations, as shown in Figure 10-3
- Propagation delays and matching:
 - A to B = C to D
 - Matching skew: < 60 ps

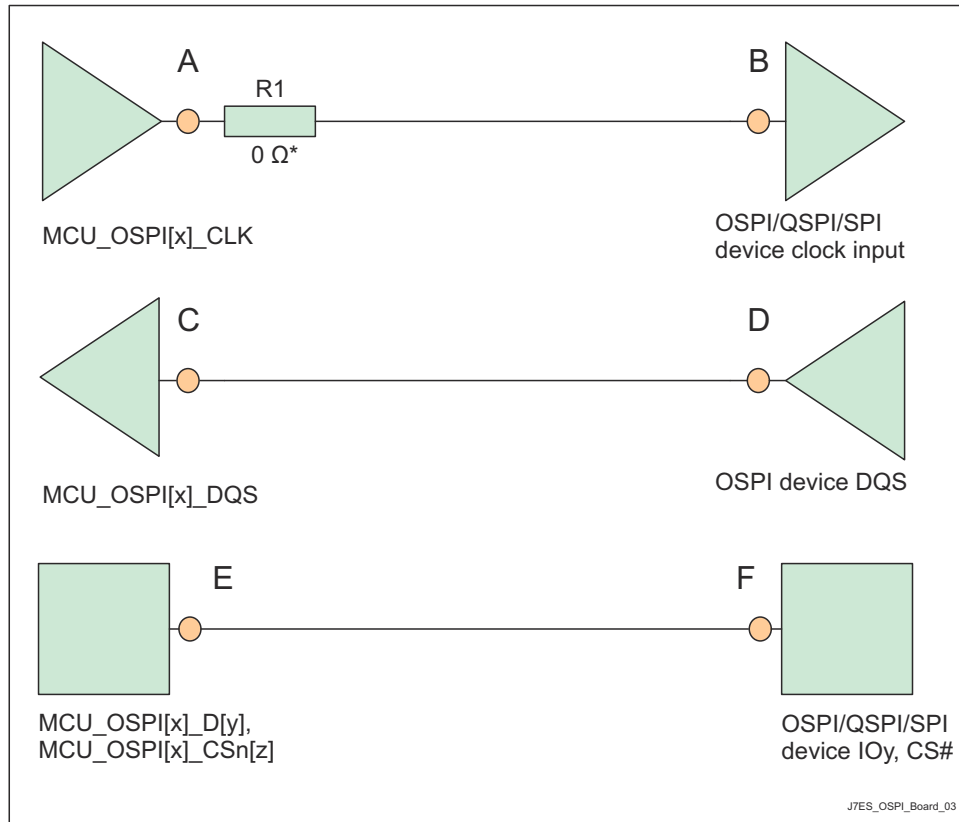

* 0 Ω resistor (R1), located as close as possible to the MCU_OSPI[x]_CLK pin, is a placeholder for fine tuning, if needed.

Figure 10-3. OSPI Interface High Level Schematic

10.3 USB VBUS Design Guidelines

The USB 3.1 specification allows the VBUS voltage to be as high as 5.5 V for normal operation, and as high as 20 V when the Power Delivery addendum is supported. Some automotive applications require a max voltage to be 30 V.

The device requires the VBUS signal voltage be scaled down using an external resistor divider (as shown in the [Figure 10-4](#)), which limits the voltage applied to the actual device pin (USB0_VBUS). The tolerance of these external resistors should be equal to or less than 1%, and the leakage current of zener diode at 5 V should be less than 100 nA.⁽¹⁾

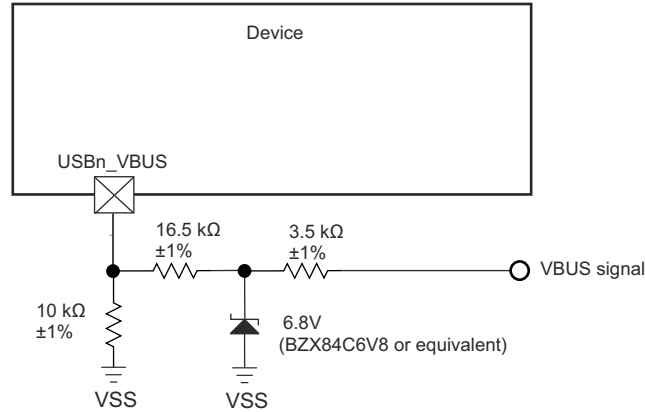

J7ES_USB_VBUS_01

Figure 10-4. USB VBUS Detect Voltage Divider / Clamp Circuit

The USB0_VBUS pin can be considered to be fail-safe because the external circuit in [Figure 10-4](#) limits the input current to the actual device pin in a case where VBUS is applied while the device is powered off.

10.4 System Power Supply Monitor Design Guidelines using VMON/POK

The VMON1_ER_VSYS pin provides a way to monitor a system power supply. This system power supply is typically a single pre-regulated power source for the entire system. This supply is monitored by comparing the output of an external voltage divider circuit sourced by this supply with an internal voltage reference, with a power fail event being triggered when the voltage applied to VMON1_ER_VSYS drops below the internal reference voltage. The actual system power supply voltage trip point is determined by the system designer when selecting component values used to implement the external resistor voltage divider circuit. When designing the resistor divider circuit it is important to understand various factors which contribute to variability in the system power supply monitor trip point. The first thing to consider is the initial accuracy of the VMON1_ER_VSYS input threshold which has a nominal value of 0.45 V, with a variation of $\pm 3\%$. Precision 1% resistors with similar thermal coefficient are recommended for implementing the resistor voltage divider. This minimizes variability contributed by resistor value tolerances. Input leakage current associated with VMON1_ER_VSYS must also be considered since any current flowing into the pin creates a loading error on the voltage divider output. The VMON1_ER_VSYS input leakage current may be in the range of 10 nA to 2.5 μ A when applying 0.45 V.

Note

The resistor voltage divider shall be designed such that its output voltage never exceeds the maximum value defined in [Recommended Operating Conditions](#) during normal operating conditions.

[Figure 10-5](#) presents an example, where the system power supply is nominally 5 V and the maximum trigger threshold is 5 V - 10%, or 4.5 V.

For this example, it is important to understand which variables effect the maximum trigger threshold when selecting resistor values. It is obvious a device which has a VMON1_ER_VSYS input threshold of 0.45 V + 3% needs to be considered when trying to design a voltage divider that doesn't trip until the system supply drops 10%. The effect of resistor tolerance and input leakage also needs to be considered, but how these contributions effect the maximum trigger point may not be obvious. When selecting component values which produce a maximum trigger voltage, the system designer must consider a condition where the value of R1 is 1% low and the value of R2 is 1% high combined with a condition where input leakage current for the VMON1_ER_VSYS pin is 2.5 μ A. When implementing a resistor divider where R1 = 4.81 K Ω and R2 = 40.2 K Ω , the result is a maximum trigger threshold of 4.523 V.

Once component values have been selected to satisfy the maximum trigger voltage as described above, the system designer can determine the minimum trigger voltage by calculating the applied voltage that produces an output voltage of 0.45 V - 3% when the value of R1 is 1% high and the value of R2 is 1% low, and the input

leakage current is 10 nA, or zero. Using an input leakage of zero with the resistor values given above, the result is a minimum trigger threshold of 4.008 V.

This example demonstrates a system power supply voltage trip point that ranges from 4.008 V to 4.523 V. Approximately 250 mV of this range is introduced by VMON1_ER_VSYS input threshold accuracy of $\pm 3\%$, approximately 150 mV of this range is introduced by resistor tolerance of $\pm 1\%$, and approximately 100 mV of this range is introduced by loading error when VMON1_ER_VSYS input leakage current is 2.5 μA .

The resistor values selected in this example produces approximately 100 μA of bias current through the resistor divider when the system supply is 4.5 V. The 100 mV of loading error mentioned above could be reduced to about 10 mV by increasing the bias current through the resistor divider to approximately 1 mA. So resistor divider bias current vs loading error is something the system designer needs to consider when selecting component values.

The system designer should also consider implementing a noise filter on the voltage divider output since VMON1_ER_VSYS has minimum hysteresis and a high-bandwidth response to transients. This could be done by installing a capacitor across R1 as shown in Figure 10-5. However, the system designer must determine the response time of this filter based on system supply noise and expected response to transient events.

Figure 10-5 presents an example, when the system power supply voltage is nominally 5 V and the desired trigger threshold is -10% or 4.5 V.

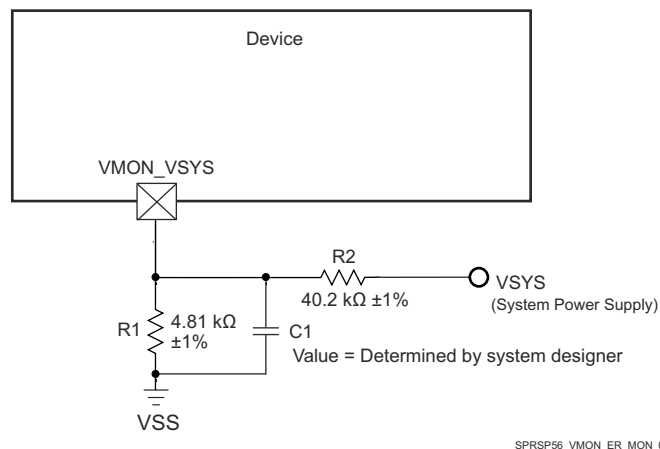

Figure 10-5. System Supply Monitor Voltage Divider Circuit

The **VMON2_IR_VCPU** pin provides a way to monitor VDD_CPU power supply. Must be externally connected as close as possible to VDD_CPU pin on the board. SoCs that have a **VMON6_IR_VEXT0P8** can optionally monitor other domains such as VDD_CORE or VDD_MCU. Similarly, those signals should be as close as possible to VDD_CORE or VDD_MCU pin on the board.

The **VMON3_IR_VEXT1P8** and **VMON4_IR_VEXT1P8** pins provide a way to monitor an external 1.8-V power supply. The **VMON5_IR_VEXT3P3** pin provides a way to monitor an external 3.3-V power supply. An internal resistor divider with software control is implemented inside the SoC. Software can program the internal resistor divider to create appropriate under voltage and over voltage interrupts. These pins should not be sourced from an external resistor divider. If the monitored voltage requires adjustment, be sure to buffer the divided voltage prior connecting to monitor pin.

10.5 High Speed Differential Signal Routing Guidance

The [High Speed Interface Layout Guidelines](#) provides guidance for successful routing of the high speed differential signals. This includes PCB stackup and materials guidance as well as routing skew, length and spacing limits. TI supports *only* designs that follow the board design guidelines contained in the application report.

10.6 Thermal Solution Guidance

The [Thermal Design Guide for DSP and ARM Application Processors](#) provides guidance for successful implementation of a thermal solution for system designs containing this device. This document provides background information on common terms and methods related to thermal solutions. TI only supports designs that follow system design guidelines contained in the application report.

11 Device and Documentation Support

TI offers an extensive line of development tools. Tools and software to evaluate the performance of the device, generate code, and develop solutions are listed below.

11.1 Device Nomenclature

To designate the stages in the product development cycle, TI assigns prefixes to the part numbers of all microprocessors (MPUs) and support tools. Each device has one of three prefixes: X, P, or null (no prefix) (for example, AM69, AM69A). Texas Instruments recommends two of three possible prefix designators for its support tools: TMDX and TMDS. These prefixes represent evolutionary stages of product development from engineering prototypes (TMDX) through fully qualified production devices and tools (TMDS).

Device development evolutionary flow:

- X** Experimental device that is not necessarily representative of the final device's electrical specifications and may not use production assembly flow.
- P** Prototype device that is not necessarily the final silicon die and may not necessarily meet final electrical specifications.
- null** Production version of the silicon die that is fully qualified.

Support tool development evolutionary flow:

- TMDX** Development-support product that has not yet completed Texas Instruments internal qualification testing.
- TMDS** Fully-qualified development-support product.

X and P devices and TMDX development-support tools are shipped against the following disclaimer:

"Developmental product is intended for internal evaluation purposes."

Production devices and TMDS development-support tools have been characterized fully, and the quality and reliability of the device have been demonstrated fully. TI's standard warranty applies.

Predictions show that prototype devices (X or P) have a greater failure rate than the standard production devices. Texas Instruments recommends that these devices not be used in any production system because their expected end-use failure rate still is undefined. Only qualified production devices are to be used.

For orderable part numbers of AM69, AM69A devices in the ALY, AND package types, see the Package Option Addendum of this document, the TI website (ti.com), or contact your TI sales representative.

11.1.1 Standard Package Symbolization

Note

Some devices may have a cosmetic circular marking visible on the top of the device package which results from the production test process. In addition, some devices may also show a color variation in the package substrate which results from the substrate manufacturer. These differences are cosmetic only with no reliability impact.

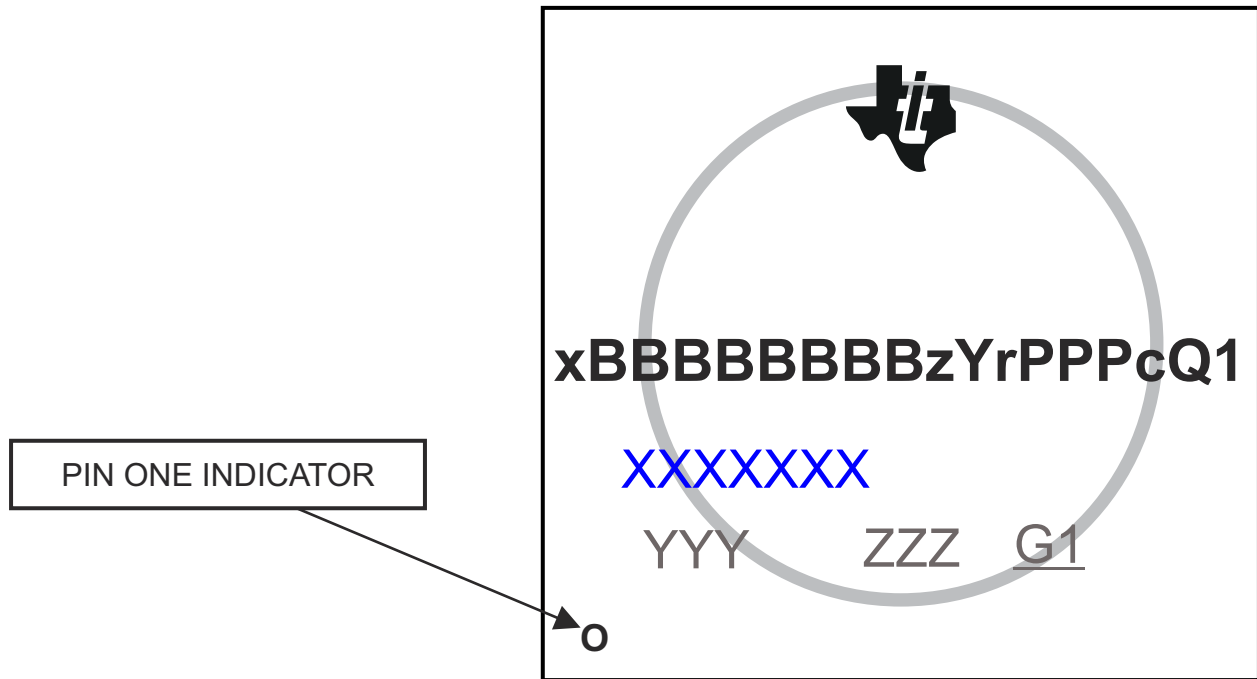

Figure 11-1. Printed Device Reference

11.1.2 Device Naming Convention

Note

BLANK in the symbol or part number is collapsed so there are no gaps between characters.

Table 11-1. Nomenclature Description

FIELD PARAMETER	FIELD DESCRIPTION	VALUE	DESCRIPTION
a	Device evolution stage	X	Prototype
		P	Preproduction (production test flow, no reliability data)
		BLANK ⁽¹⁾	Production
BBBBBBB	Base production part number	AM69A98	See Device Comparison
		AM69A94	
		AM69A78	
		AM6958	
		AM6954	
r	Device revision	A	SR1.0
Z	Device Speed Grade	T	See Speed Grade Maximum Frequency .
		OTHER	Alternate speed grade
f	Features (see Device Comparison)	G	Base, no additional Features
Y	Functional Safety ⁽³⁾	G	Non-Functional Safety
y	Security	G	Non-Secure
		Other	Secure
t	Temperature ⁽²⁾	A	–40°C to 105°C - Extended Industrial (see Recommended Operation Conditions)
		H	0°C to 95°C - Commercial (see Recommended Operation Conditions)
		I	–40°C to 125°C - Automotive (see Recommended Operation Conditions)
PPP	Package Designator	ALY	ALY FCBGA-N1414 (31mm x 31mm) Package (<i>Production Data</i>)
		AND	AND FCBGA-N1063 (27mm x 27mm) Package (<i>Advance Information</i>)
Q1	Automotive Designator	Q1	Auto Qualified (Q100)
		BLANK ⁽¹⁾	Standard
xxxxxxx			Lot Trace Code (LTC)
YYY			Production Code, For TI use only
ZZZ			Production Code, For TI use only
O			Pin one designator
G1			ECAT - Green package designator

(1) BLANK in the symbol or part number is collapsed so there are no gaps between characters.

(2) Applies to device max junction temperature.

(3) Functional Safety is not supported on this device family, if interested in this feature, please see the [TDA4VH device family](#).

11.2 Tools and Software

The following products support development for AM69, AM69A platforms:

Development Tools

Code Composer Studio™ Integrated Development Environment Code Composer Studio (CCS) Integrated Development Environment (IDE) is a development environment that supports TI's Microcontroller and Embedded Processors portfolio. Code Composer Studio comprises a suite of tools used to develop and debug embedded applications. It includes an optimizing C/C++ compiler, source code editor, project build environment, debugger, profiler, and many other features. The intuitive IDE provides a single user interface taking you through each step of the application development flow. Familiar tools and interfaces allow users to get started faster than ever before. Code Composer Studio combines the advantages of the Eclipse software framework with advanced embedded debug capabilities from TI resulting in a compelling feature-rich development environment for embedded developers.

Pin mux tool The Pin MUX Utility is a software tool which provides a Graphical User Interface for configuring pin multiplexing settings, resolving conflicts and specifying I/O cell characteristics for TI MPUs. Results are output as C header/code files that can be imported into software development kits (SDKs) or used to configure customer's custom software. Version 4 of the Pin Mux utility adds the capability of automatically selecting a mux configuration that satisfies the entered requirements.

For a complete listing of development-support tools for the processor platform, visit the Texas Instruments website at ti.com. For information on pricing and availability, contact the nearest TI field sales office or authorized distributor.

11.3 Support Resources

TI E2E™ support forums are an engineer's go-to source for fast, verified answers and design help — straight from the experts. Search existing answers or ask your own question to get the quick design help you need.

Linked content is provided "AS IS" by the respective contributors. They do not constitute TI specifications and do not necessarily reflect TI's views; see TI's [Terms of Use](#).

11.4 Trademarks

eMMC™ is a trademark of MultiMediaCard Association.

Jacinto™, C7000™, Code Composer Studio™, and TI E2E™ are trademarks of Texas Instruments.

CoreSight™ is a trademark of Arm Limited (or its subsidiaries) in the US and/or elsewhere.

Arm® and Cortex® are registered trademarks of Arm Limited (or its subsidiaries) in the US and/or elsewhere.

PCI-Express® is a registered trademark of PCI-SIG.

Secure Digital® is a registered trademark of SD Card Association.

MIPI® is a registered trademark of MIPI Alliance, Inc.

All trademarks are the property of their respective owners.

11.5 Electrostatic Discharge Caution



This integrated circuit can be damaged by ESD. Texas Instruments recommends that all integrated circuits be handled with appropriate precautions. Failure to observe proper handling and installation procedures can cause damage.

ESD damage can range from subtle performance degradation to complete device failure. Precision integrated circuits may be more susceptible to damage because very small parametric changes could cause the device not to meet its published specifications.

11.6 Glossary

TI Glossary This glossary lists and explains terms, acronyms, and definitions.

12 Revision History

Changes from December 16, 2023 to June 30, 2024 (from Revision B (DECEMBER 2023) to Revision C (JUNE 2024))

Page

- **Global:** Updated/Changed the document product status from "Production Data" to "Production Data Mixed" ("**AND**" MECH variant package is "Advance Information")..... 1
- **Global:** Added the "AND" 27mm × 27mm MECH variant package support data (ADVANCE INFORMATION) 1
- **Global:** Deleted the VPFE subsection from Detailed Description section as not applicable to this device..... 1
- (Features): Added MECH package "AND", 1063-pin count, 27mm square, 16-nmFinFET technology bullets (*new*)..... 1
- (Features): Deleted the "OLDI/LVDS (4 lanes - 2x) and 24-bit RGB parallel interface" bullet under the *Display subsystem supports:* 1
- (Features): Updated/Changed the "Support for 1,2,3, or 4 data lane mode up to ..." bullet from "1.5Gbps" to "2.5Gbps"..... 1
- (Device Comparison): Added "AM69A94 (27MM)" and "AM6954 (27MM)" columns and supported features... 6
- (Device Comparison): Updated/changed the Ethernet Interfaces SERDES features and associated footnotes to clarify the 27MM package columns and supported features additions..... 6
- (Device Comparison): Added separate MECHANICAL PACKAGES rows..... 6
- (Device Comparison): Added a cross-reference and associated footnote to the Arm A72 Quad Core devices. 6
- (Device Comparison): Added a cross-reference to the "Deep Learning Accelerator (32 TOPS)" row for the AM69A94 device..... 6
- (Terminal Configuration and Functions/Pin Diagrams): Added pin diagrams and descriptions for both "ALY" and "AND" packages (Top View)..... 9
- (Terminal Configuration and Functions/Pin Attributes): Updated/Changed table to include "AND" package data (*new*)..... 9
- (Terminal Configuration and Functions/Signal Descriptions): Updated/Changed tables to support, where applicable, "AND" package data (*new*)..... 9
- (Thermal Resistance Characteristics for AND Package): Added new section..... 155
- (OSC1 Crystal Electrical Characteristics Table): Updated OSC1 frequencies from finite values to a range from 19.2 MHz to 27 MHz..... 186
- (Power Distribution Network Implementation Guidance): Updated/Changed the user's guide doc title and ulink association..... 290
- (Reset): Added description for four reset pins and two reset status pins..... 290
- (Hardware Design Guide): Added brief description on the design guide use case..... 290
- (Device Naming Convention): Updated/Changed the Package Designator for "ALY" to "ALY FCBGA-N1414 (31mm x 31mm) Package"..... 300
- (Device Naming Convention): Added *new* Package Designator row for "AND", "AND FCBGA-N1063 (27mm x 27mm) Package (Advance Information)"..... 300

13 Mechanical, Packaging, and Orderable Information

13.1 Packaging Information

The following pages include mechanical, packaging, and orderable information. This information is the most current data available for the designated devices. This data is subject to change without notice and revision of this document. For browser-based versions of this data sheet, refer to the left-hand navigation.

PACKAGING INFORMATION

Orderable Device	Status (1)	Package Type	Package Drawing	Pins	Package Qty	Eco Plan (2)	Lead finish/ Ball material (6)	MSL Peak Temp (3)	Op Temp (°C)	Device Marking (4/5)	Samples
XAM6958ATGGHAALY	ACTIVE	FCBGA	ALY	1414	1	TBD	Call TI	Call TI	-40 to 105		Samples
XAM69A98ATNGHAALY	ACTIVE	FCBGA	ALY	1414	1	TBD	Call TI	Call TI	-40 to 105		Samples

(1) The marketing status values are defined as follows:

ACTIVE: Product device recommended for new designs.

LIFEBUY: TI has announced that the device will be discontinued, and a lifetime-buy period is in effect.

NRND: Not recommended for new designs. Device is in production to support existing customers, but TI does not recommend using this part in a new design.

PREVIEW: Device has been announced but is not in production. Samples may or may not be available.

OBSOLETE: TI has discontinued the production of the device.

(2) **RoHS:** TI defines "RoHS" to mean semiconductor products that are compliant with the current EU RoHS requirements for all 10 RoHS substances, including the requirement that RoHS substance do not exceed 0.1% by weight in homogeneous materials. Where designed to be soldered at high temperatures, "RoHS" products are suitable for use in specified lead-free processes. TI may reference these types of products as "Pb-Free".

RoHS Exempt: TI defines "RoHS Exempt" to mean products that contain lead but are compliant with EU RoHS pursuant to a specific EU RoHS exemption.

Green: TI defines "Green" to mean the content of Chlorine (Cl) and Bromine (Br) based flame retardants meet JS709B low halogen requirements of <=1000ppm threshold. Antimony trioxide based flame retardants must also meet the <=1000ppm threshold requirement.

(3) MSL, Peak Temp. - The Moisture Sensitivity Level rating according to the JEDEC industry standard classifications, and peak solder temperature.

(4) There may be additional marking, which relates to the logo, the lot trace code information, or the environmental category on the device.

(5) Multiple Device Markings will be inside parentheses. Only one Device Marking contained in parentheses and separated by a "~" will appear on a device. If a line is indented then it is a continuation of the previous line and the two combined represent the entire Device Marking for that device.

(6) Lead finish/Ball material - Orderable Devices may have multiple material finish options. Finish options are separated by a vertical ruled line. Lead finish/Ball material values may wrap to two lines if the finish value exceeds the maximum column width.

Important Information and Disclaimer:The information provided on this page represents TI's knowledge and belief as of the date that it is provided. TI bases its knowledge and belief on information provided by third parties, and makes no representation or warranty as to the accuracy of such information. Efforts are underway to better integrate information from third parties. TI has taken and continues to take reasonable steps to provide representative and accurate information but may not have conducted destructive testing or chemical analysis on incoming materials and chemicals. TI and TI suppliers consider certain information to be proprietary, and thus CAS numbers and other limited information may not be available for release.

In no event shall TI's liability arising out of such information exceed the total purchase price of the TI part(s) at issue in this document sold by TI to Customer on an annual basis.

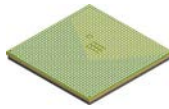

PACKAGE OUTLINE

ALY1414A

FCBGA - 3.341 mm max height

BALL GRID ARRAY

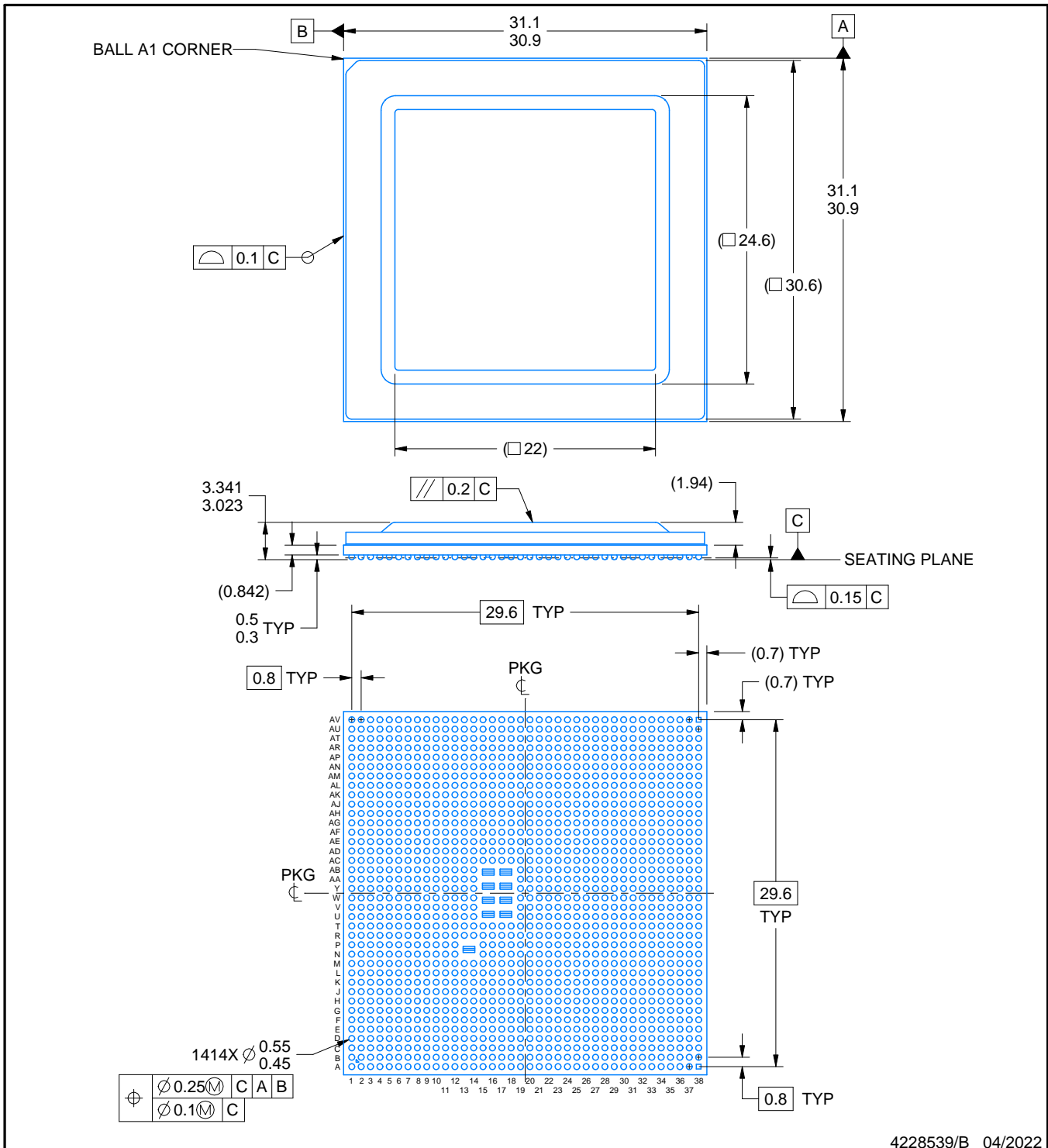

NOTES:

1. All linear dimensions are in millimeters. Any dimensions in parenthesis are for reference only. Dimensioning and tolerancing per ASME Y14.5M.
2. This drawing is subject to change without notice.

EXAMPLE BOARD LAYOUT

ALY1414A

FCBGA - 3.341 mm max height

BALL GRID ARRAY

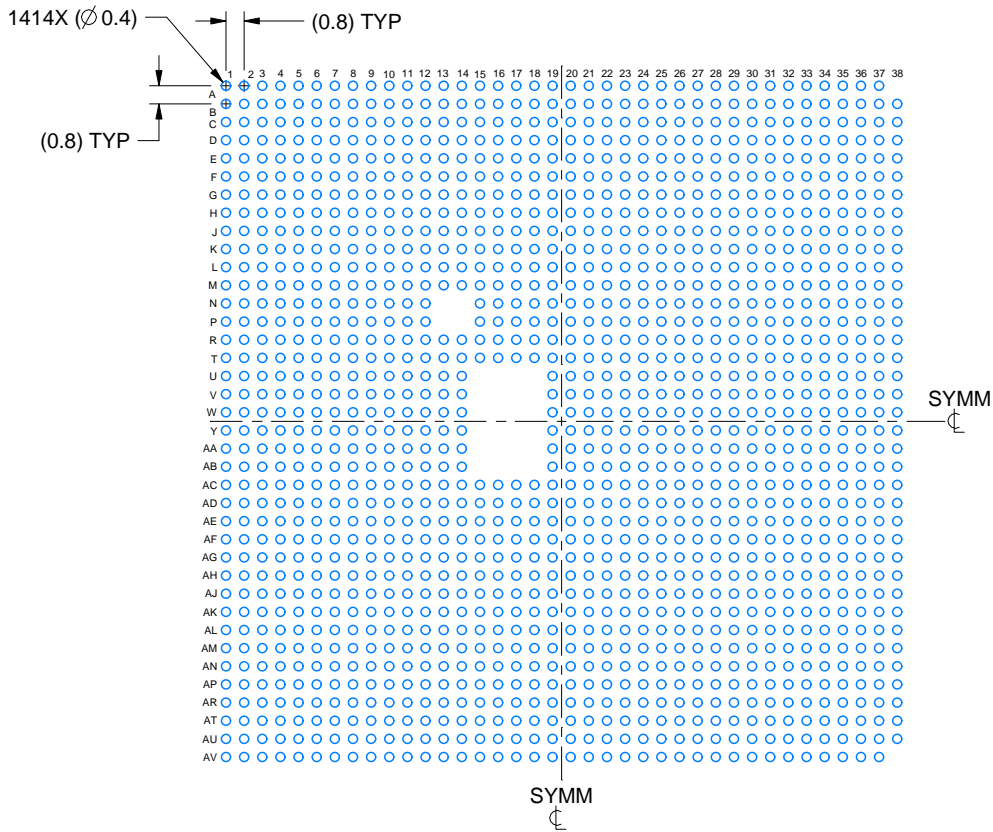

LAND PATTERN EXAMPLE
EXPOSED METAL SHOWN
SCALE:3X

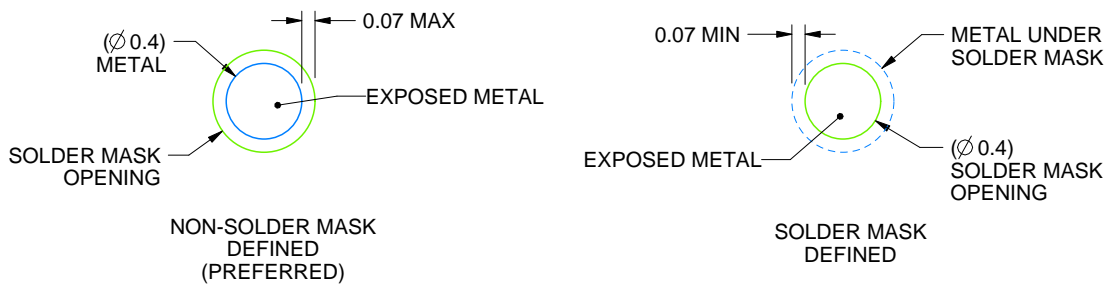

SOLDER MASK DETAILS
NOT TO SCALE

4228539/B 04/2022

NOTES: (continued)

- Final dimensions may vary due to manufacturing tolerance considerations and also routing constraints. For more information, see Texas Instruments literature number SPRU811 (www.ti.com/lit/spru811).

EXAMPLE STENCIL DESIGN

ALY1414A

FCBGA - 3.341 mm max height

BALL GRID ARRAY

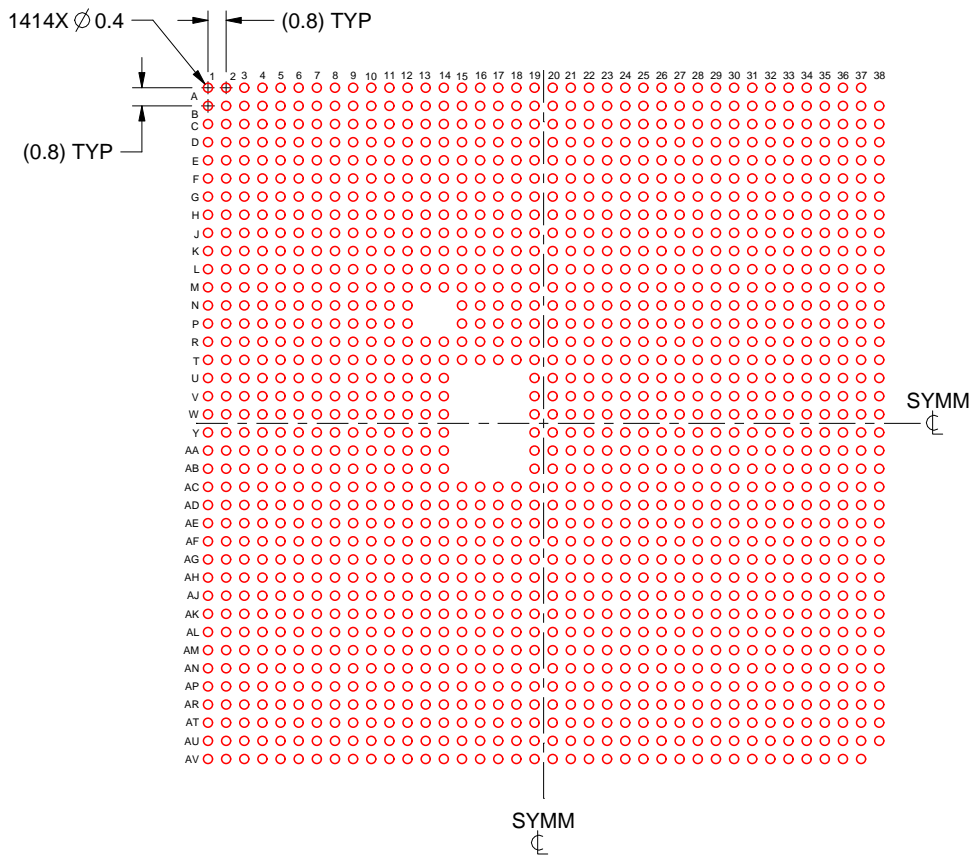

SOLDER PASTE EXAMPLE
BASED ON 0.15 mm THICK STENCIL
SCALE: 3X

4228539/B 04/2022

NOTES: (continued)

4. Laser cutting apertures with trapezoidal walls and rounded corners may offer better paste release.

AND1063A

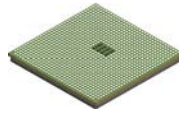

PACKAGE OUTLINE

FCBGA - 3.24 mm max height

BALL GRID ARRAY

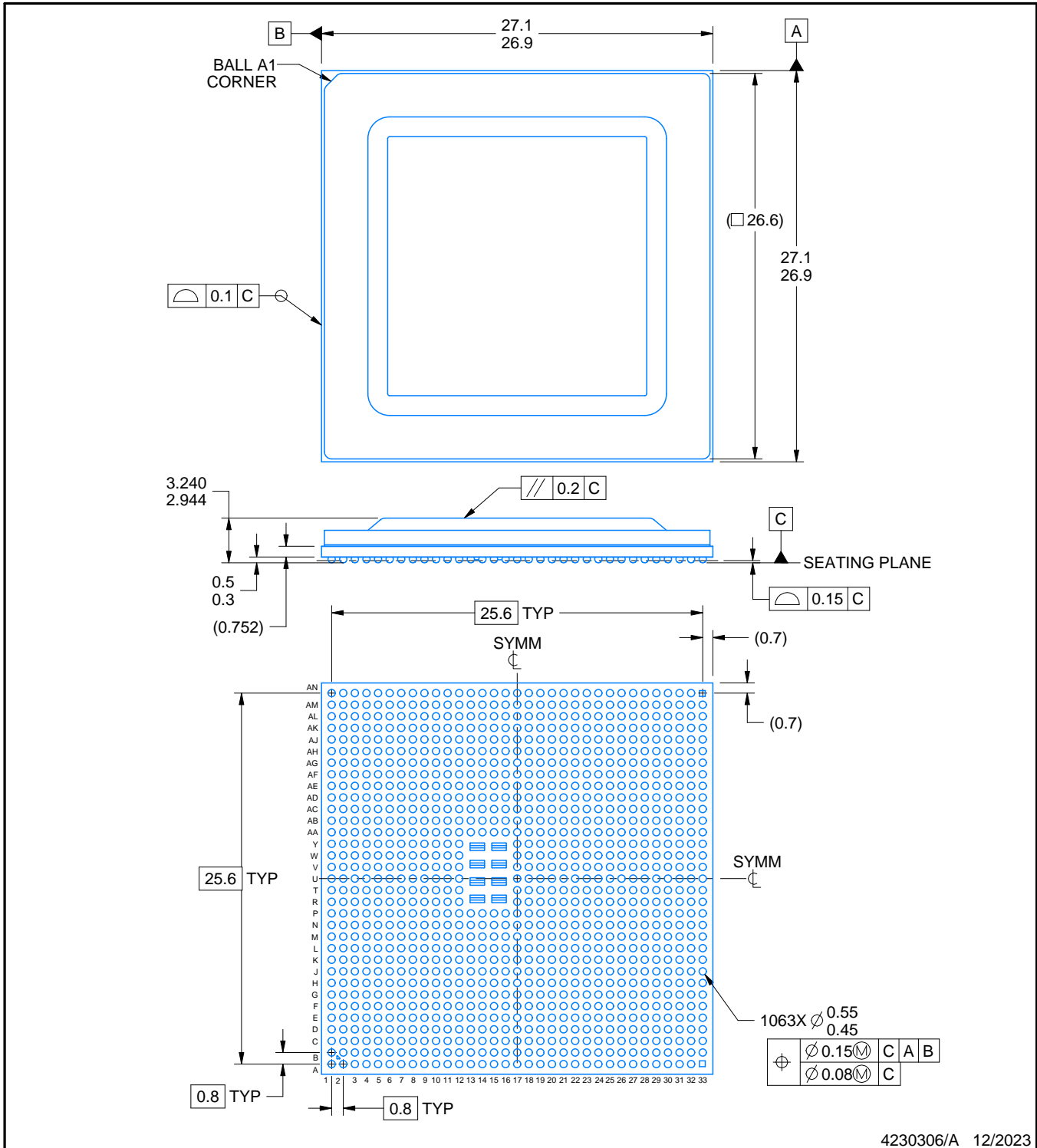

4230306/A 12/2023

NOTES:

- All linear dimensions are in millimeters. Any dimensions in parenthesis are for reference only. Dimensioning and tolerancing per ASME Y14.5M.
- This drawing is subject to change without notice.

EXAMPLE BOARD LAYOUT

AND1063A

FCBGA - 3.24 mm max height

BALL GRID ARRAY

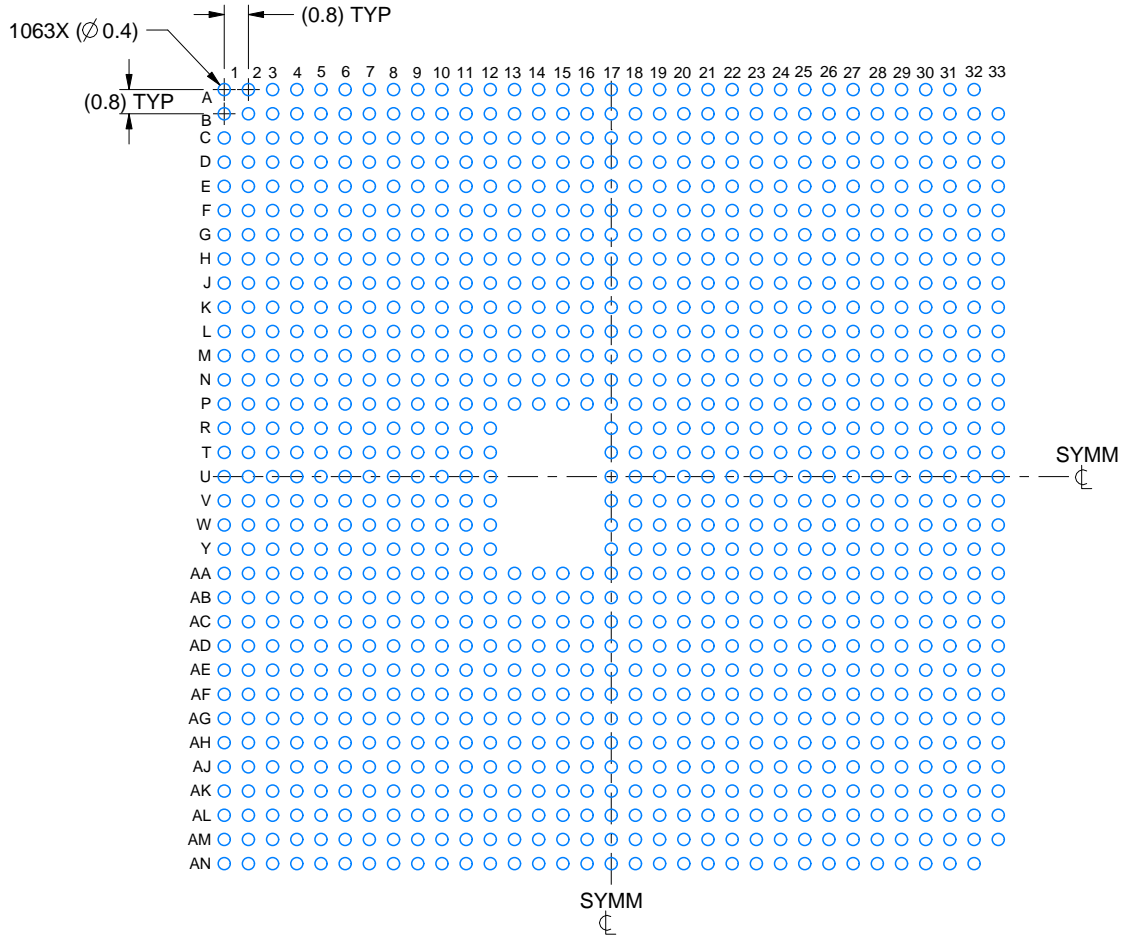

LAND PATTERN EXAMPLE
EXPOSED METAL SHOWN
SCALE: 4X

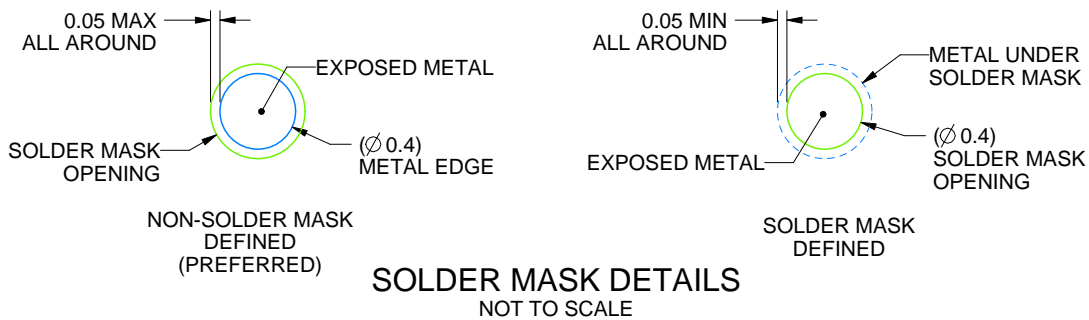

4230306/A 12/2023

NOTES: (continued)

- Final dimensions may vary due to manufacturing tolerance considerations and also routing constraints. For information, see Texas Instruments literature number SPRAA99 (www.ti.com/lit/spraa99).

EXAMPLE STENCIL DESIGN

AND1063A

FCBGA - 3.24 mm max height

BALL GRID ARRAY

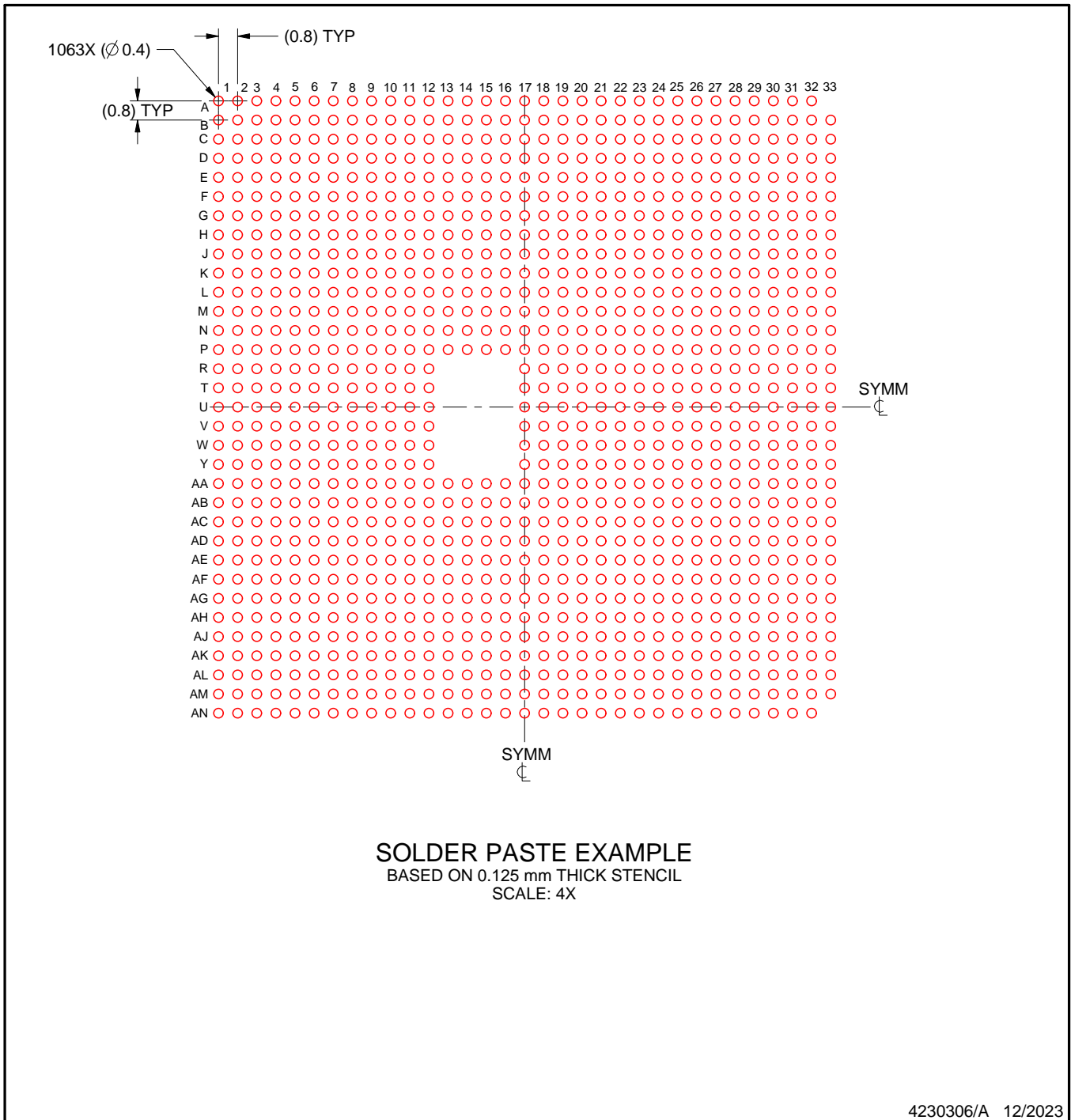

NOTES: (continued)

4. Laser cutting apertures with trapezoidal walls and rounded corners may offer better paste release.

IMPORTANT NOTICE AND DISCLAIMER

TI PROVIDES TECHNICAL AND RELIABILITY DATA (INCLUDING DATA SHEETS), DESIGN RESOURCES (INCLUDING REFERENCE DESIGNS), APPLICATION OR OTHER DESIGN ADVICE, WEB TOOLS, SAFETY INFORMATION, AND OTHER RESOURCES "AS IS" AND WITH ALL FAULTS, AND DISCLAIMS ALL WARRANTIES, EXPRESS AND IMPLIED, INCLUDING WITHOUT LIMITATION ANY IMPLIED WARRANTIES OF MERCHANTABILITY, FITNESS FOR A PARTICULAR PURPOSE OR NON-INFRINGEMENT OF THIRD PARTY INTELLECTUAL PROPERTY RIGHTS.

These resources are intended for skilled developers designing with TI products. You are solely responsible for (1) selecting the appropriate TI products for your application, (2) designing, validating and testing your application, and (3) ensuring your application meets applicable standards, and any other safety, security, regulatory or other requirements.

These resources are subject to change without notice. TI grants you permission to use these resources only for development of an application that uses the TI products described in the resource. Other reproduction and display of these resources is prohibited. No license is granted to any other TI intellectual property right or to any third party intellectual property right. TI disclaims responsibility for, and you will fully indemnify TI and its representatives against, any claims, damages, costs, losses, and liabilities arising out of your use of these resources.

TI's products are provided subject to [TI's Terms of Sale](#) or other applicable terms available either on [ti.com](https://www.ti.com) or provided in conjunction with such TI products. TI's provision of these resources does not expand or otherwise alter TI's applicable warranties or warranty disclaimers for TI products.

TI objects to and rejects any additional or different terms you may have proposed.

Mailing Address: Texas Instruments, Post Office Box 655303, Dallas, Texas 75265
Copyright © 2024, Texas Instruments Incorporated