

# bq34210-Q1 Automotive 1-Series Cell System-Side CEDV Fuel Gauge for Rarely Discharged Batteries

## 1 Features

- Automotive-Qualified AEC-Q100, Grade 3
- 1-Series Cell Battery Fuel Gauge Supports Li-Ion, LiFePO<sub>4</sub>, and NiMH (3-Cell) Chemistries
  - Resides on System Board
  - Powers Directly from the Battery with Integrated LDO
  - Supports a Low-Value External Sense Resistor (10 mΩ)
- Learning Load Enable (LEN) from Host
- Ultra-Low Power Consumption in NORMAL (50 μA) and SLEEP (9 μA) Modes
- Supports Replacement Batteries
- Accurate End-of-Service (EOS) Determination for Batteries in Rarely Discharged Applications
- CEDV Gas Gauge for 1-Series Cell Batteries, Providing:
  - State-of-Charge (SOC)
  - Time-to-Empty (TTE)
  - State-of-Health (SOH)
- High-Side and Low-Side Current Sensing Options
- Internal Temperature Sensor OR External Thermistor
- Microcontroller Peripheral Interface Supports:
  - 400-kHz I<sup>2</sup>C™ Serial Interface
  - Configurable Interrupt (ALERT) for SOC, Battery Levels, Temperature Faults, and Charge/Discharge Status

## 2 Applications

- eCall Systems
- Telematics Backup Systems
- Uninterruptible Power Supply (UPS) Backup Systems
- Emergency Battery Power Modules

## 3 Description

The bq34210-Q1 1-Series Cell System-Side CEDV Fuel Gauge provides fuel gauging and End-of-Service (EOS) Determination for 1-series cell batteries in applications that encounter infrequent discharge, such as eCall systems and uninterruptible power supplies (UPS) for backup during power failures, where batteries may stay connected to a charging power source most of their lifetime until needed. The bq34210-Q1 fuel gauge supports multiple battery chemistries, including Li-Ion, LiFePO<sub>4</sub>, and NiMH.

The gas gauging function uses voltage, current, and temperature data along with Compensated End-of-Discharge (CEDV) technology to provide State-of-Charge (SOC) and State-of-Health (SOH) data. The device's EOS Determination function alerts when battery capability has degraded and is approaching the end of its usable service.

Battery fuel gauging with the bq34210-Q1 fuel gauge requires connections only to PACK+ (P+) and PACK– (P–) for a removable battery pack or embedded battery management system.

### Device Information<sup>(1)</sup>

PART NUMBER	PACKAGE	BODY SIZE (NOM)
bq34210-Q1	PW (14)	5.00 mm x 4.40 mm x 1.00 mm

(1) For all available packages, see the orderable addendum at the end of the data sheet.

### Simplified Schematic

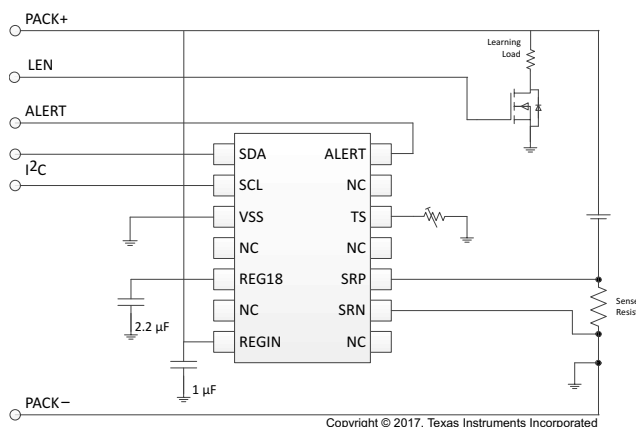

## Table of Contents

<b>1</b>	<b>Features</b> .....	<b>1</b>	<b>7</b>	<b>Detailed Description</b> .....	<b>8</b>
<b>2</b>	<b>Applications</b> .....	<b>1</b>	7.1	Overview .....	8
<b>3</b>	<b>Description</b> .....	<b>1</b>	7.2	Functional Block Diagram .....	8
<b>4</b>	<b>Revision History</b> .....	<b>2</b>	7.3	Feature Description .....	8
<b>5</b>	<b>Pin Configuration and Functions</b> .....	<b>3</b>	7.4	Device Functional Modes .....	11
<b>6</b>	<b>Specifications</b> .....	<b>3</b>	<b>8</b>	<b>Application and Implementation</b> .....	<b>12</b>
6.1	Absolute Maximum Ratings .....	3	8.1	Application Information .....	12
6.2	ESD Ratings .....	4	8.2	Typical Applications .....	12
6.3	Recommended Operating Conditions .....	4	<b>9</b>	<b>Power Supply Recommendation</b> .....	<b>14</b>
6.4	Thermal Information .....	4	9.1	Power Supply Decoupling .....	14
6.5	Supply Current .....	4	<b>10</b>	<b>Layout</b> .....	<b>15</b>
6.6	Digital Input and Output DC Characteristics .....	4	10.1	Layout Guidelines .....	15
6.7	LDO Regulator, Wake-up, and Auto-Shutdown DC Characteristics .....	5	10.2	Layout Example .....	15
6.8	LDO Regulator, Wake-up, and Auto-Shutdown AC Characteristics .....	5	<b>11</b>	<b>Device and Documentation Support</b> .....	<b>17</b>
6.9	ADC (Temperature and Cell Measurement) Characteristics .....	5	11.1	Device Support .....	17
6.10	Integrating ADC (Coulomb Counter) Characteristics .....	5	11.2	Documentation Support .....	17
6.11	I <sup>2</sup> C-Compatible Interface Communication Timing .....	6	11.3	Community Resources .....	17
6.12	SHUTDOWN and WAKE-UP Timing .....	7	11.4	Trademarks .....	17
6.13	Typical Characteristics .....	7	11.5	Electrostatic Discharge Caution .....	17
			11.6	Glossary .....	17
			<b>12</b>	<b>Mechanical, Packaging, and Orderable Information</b> .....	<b>17</b>

## 4 Revision History

DATE	REVISION	NOTES
September 2018	*	Initial Release

## 5 Pin Configuration and Functions

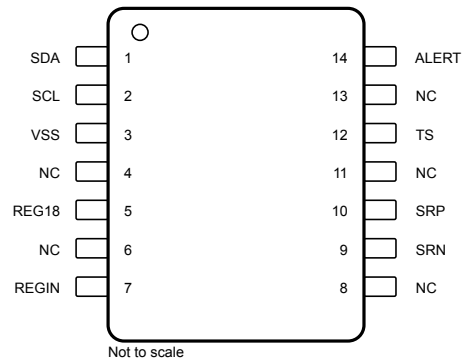

**Pin Functions**

NUMBER	NAME	TYPE	DESCRIPTION
1	SDA	IO <sup>(1)</sup>	Open drain slave I <sup>2</sup> C serial communication data line. Use with a 10-kΩ pullup resistor (typical).
2	SCL	IO	Slave I <sup>2</sup> C serial communication clock input. Use with a 10-kΩ pullup resistor (typical).
3	VSS	P	Device ground
5	REG18	P	Capacitor required for the 1.8-V integrated LDO. Decouple with 2.2-μF ceramic capacitor to VSS.
7	REGIN	P	Battery voltage input and integrated LDO input. Decouple with 1-μF ceramic capacitor to VSS.
9	SRN	AI	Analog input pin connected to the internal coulomb-counter peripheral for integrating a small voltage between SRP and SRN where the voltage at SRN will be lower than SRP during a charging event
10	SRP	AI	Analog input pin connected to the internal coulomb-counter peripheral for integrating a small voltage between SRP and SRN where the voltage at SRP will be higher than SRN during a charging event
12	TS	AI	Pack thermistor voltage sense (use 103AT-type thermistor). Disable TS with a 10-kΩ resistor to VSS. Do not leave floating.
14	ALERT	IO	Open drain ALERT output, requires a pullup resistor (typical 10 kΩ). Used as an input to exit SHUTDOWN mode
4, 6, 8, 11, 13	NC	NC	No internal connection

(1) IO = Digital input-output, AI = Analog input, P = Power connection, NC = No internal connection

## 6 Specifications

### 6.1 Absolute Maximum Ratings

Over operating free-air temperature range (unless otherwise noted)<sup>(1)</sup>

		MIN	MAX	UNIT
V <sub>REGIN</sub>	REGIN pin input voltage range	-0.3	5.5	V
V <sub>SR</sub>	SRP and SRN pins input voltage range	-0.3	V <sub>REGIN</sub> + 0.3	V
	Differential voltage across SRP and SRN. ABS(SRP – SRN)	-0.3	2	V
V <sub>REG18</sub>	REG18 LDO output for capacitor only (not a supply pin)	-0.3	2	V
V <sub>IOD</sub>	Open-drain IO pins (SDA, SCL)	-0.3	5.5	V
V <sub>ALERT</sub>	Open Drain Output / Control Input (ALERT)	-0.3	5.5	V
V <sub>AI</sub>	TS	-0.3	REG18 + 0.3	V
T <sub>A</sub>	Operating free-air temperature range	-40	85	°C
	Storage temperature, T <sub>stg</sub>	-65	150	°C

(1) Stresses beyond those listed under "absolute maximum ratings" may cause permanent damage to the device. These are stress ratings only and functional operation of the device at these or any other conditions beyond those indicated under "recommended operating conditions" is not implied. Exposure to absolute-maximum-rated conditions for extended periods may affect device reliability.

## 6.2 ESD Ratings

			VALUE	UNIT
$V_{(ESD)}$	Electrostatic discharge	Human body model (HBM), per ANSI/ESDA/JEDEC JS-001 <sup>(1)</sup>	±1500	V
		Charged-device model (CDM), per JEDEC specification JESD22-C101 <sup>(2)</sup>	±250	

(1) JEDEC document JEP155 states that 500-V HBM allows safe manufacturing with a standard ESD control process.

(2) JEDEC document JEP157 states that 250-V CDM allows safe manufacturing with a standard ESD control process.

## 6.3 Recommended Operating Conditions

$T_A = 30^\circ\text{C}$  and  $V_{REGIN} = 3.6\text{ V}$  (unless otherwise noted)

			MIN	NOM	MAX	UNIT
$C_{REGIN}$ <sup>(1)</sup>	External input capacitor for internal LDO between REGIN and VSS	Nominal capacitor values specified. Recommend a 5% ceramic X5R-type capacitor located close to the device.	1			μF
$C_{REG18}$ <sup>(1)</sup>	External output capacitor for internal LDO between REG18 and VSS		2.2			μF
$V_{PU}$ <sup>(1)</sup>	External pullup voltage for open-drain pins (SDA, SCL, ALERT)		1.62	5.5		V

(1) Specified by design. Not production tested.

## 6.4 Thermal Information

THERMAL METRIC <sup>(1)</sup>		bq34210-Q1			UNIT
		PW (TSSOP)			
		14 PINS			
$R_{\theta JA}$	Junction-to-ambient thermal resistance	111.0			°C/W
$R_{\theta JCTop}$	Junction-to-case (top) thermal resistance	37.9			°C/W
$R_{\theta JB}$	Junction-to-board thermal resistance	54.8			°C/W
$\psi_{JT}$	Junction-to-top characterization parameter	3.0			°C/W
$\psi_{JB}$	Junction-to-board characterization parameter	54.2			°C/W
$R_{\theta JCbott}$	Junction-to-case (bottom) thermal resistance	n/a			°C/W

(1) For more information about traditional and new thermal metrics, see the *IC Package Thermal Metrics* application report, [SPRA953](#).

## 6.5 Supply Current

$T_A = 30^\circ\text{C}$  and  $V_{REGIN} = 3.6\text{ V}$  (unless otherwise noted)

PARAMETER	TEST CONDITIONS	MIN	TYP	MAX	UNIT
$I_{REGIN}$ <sup>(1)</sup>	NORMAL mode current	$I_{LOAD} > \text{Sleep Current}^{(2)}$		50	μA
$I_{SLP}$ <sup>(1)</sup>	SLEEP mode current	$I_{LOAD} < \text{Sleep Current}^{(2)}$		9	μA
$I_{SD}$ <sup>(1)</sup>	SHUTDOWN mode current	Fuel gauge in host commanded SHUTDOWN mode. (LDO regulator output disabled)		0.6	μA

(1) Specified by design. Not production tested.

(2) Wake Comparator disabled.

## 6.6 Digital Input and Output DC Characteristics

$T_A = -40^\circ\text{C}$  to  $85^\circ\text{C}$ , typical values at  $T_A = 30^\circ\text{C}$  and  $V_{REGIN} = 3.6\text{ V}$  (unless otherwise noted)

PARAMETER	TEST CONDITIONS	MIN	TYP	MAX	UNIT	
$V_{IH(OD)}$	Input voltage, high <sup>(2)</sup>	External pullup resistor to $V_{PU}$		$V_{PU} \times 0.7$	V	
$V_{IL}$	Input voltage, low <sup>(2)</sup>				0.6	V
$V_{OL}$	Output voltage, low <sup>(2)</sup>				0.6	V
$I_{OH}$	Output source current, high <sup>(2)</sup>				0.5	mA
$I_{OL(OD)}$	Output sink current, low <sup>(2)</sup>				-3	mA

(1) Specified by design. Not production tested.

(2) SCL, SDA, ALERT

## Digital Input and Output DC Characteristics (continued)

 $T_A = -40^{\circ}\text{C}$  to  $85^{\circ}\text{C}$ , typical values at  $T_A = 30^{\circ}\text{C}$  and  $V_{\text{REGIN}} = 3.6\text{ V}$  (unless otherwise noted)

PARAMETER		TEST CONDITIONS	MIN	TYP	MAX	UNIT
$C_{\text{IN}}^{(1)}$	Input capacitance <sup>(2)(3)</sup>				5	pF
$I_{\text{lkq}}$	Input Leakage Current <sup>(2)(3)</sup>				1	$\mu\text{A}$

(3) TS

## 6.7 LDO Regulator, Wake-up, and Auto-Shutdown DC Characteristics

 $T_A = -40^{\circ}\text{C}$  to  $85^{\circ}\text{C}$ , typical values at  $T_A = 30^{\circ}\text{C}$  and  $V_{\text{REGIN}} = 3.6\text{ V}$  (unless otherwise noted)

PARAMETER		TEST CONDITIONS	MIN	TYP	MAX	UNIT
$V_{\text{REGIN}}$	Battery and regulator input		2.45		4.5	V
$V_{\text{REG18}}$	Regulator output voltage			1.85		V
$UVLO_{\text{IT+}}$	$V_{\text{REGIN}}$ undervoltage lock-out LDO wake-up rising threshold			2		V
$UVLO_{\text{IT-}}$	$V_{\text{REGIN}}$ undervoltage lock-out LDO auto-shutdown falling threshold			1.95		V
$V_{\text{WU+}}^{(1)}$	ALERT (input) LDO Wake-up rising edge threshold <sup>(2)</sup>	LDO Wake-up from SHUTDOWN mode	1.2			V
$t_{\text{ALERT}}$	Minimum ALERT high time after $V_{\text{WU+}}$ to initiate Wake up			1		ms

(1) Specified by design. Not production tested.

(2) If the device is commanded to SHUTDOWN via I<sup>2</sup>C with  $V_{\text{REGIN}} > UVLO_{\text{IT+}}$ , a wake-up rising edge trigger is required on ALERT.

## 6.8 LDO Regulator, Wake-up, and Auto-Shutdown AC Characteristics

 $T_A = -40^{\circ}\text{C}$  to  $85^{\circ}\text{C}$ , typical values at  $T_A = 30^{\circ}\text{C}$  and  $V_{\text{REGIN}} = 3.6\text{ V}$  (unless otherwise noted)

PARAMETER		TEST CONDITIONS	MIN	TYP	MAX	UNIT
$t_{\text{SHDN}}^{(1)}$	SHUTDOWN entry time	Time delay from SHUTDOWN command to LDO output disable.			250	ms
$t_{\text{SHUP}}^{(1)}$	SHUTDOWN ALERT low time	Minimum low time of ALERT (input) in SHUTDOWN before WAKEUP	10			$\mu\text{s}$
$t_{\text{REG18}}^{(1)}$	Initial REG18 output delay			13		ms
$t_{\text{WUREG18}}^{(1)}$	Wake-up REG18 output delay	Time delay from rising edge of ALERT (input) to nominal REG18 output.		8		ms
$t_{\text{PUCD}}$	Power-up communication delay <sup>(2)</sup>	Time delay from rising edge of REGIN to NORMAL mode (includes firmware initialization time).		250		ms

(1) Specified by design. Not production tested.

(2)  $t_{\text{PUCD}}$  indicates when communication can begin. Measurements are not valid for up to 1 second after any reset.

## 6.9 ADC (Temperature and Cell Measurement) Characteristics

 $T_A = -40^{\circ}\text{C}$  to  $85^{\circ}\text{C}$ ; typical values at  $T_A = 30^{\circ}\text{C}$  and  $V_{\text{REGIN}} = 3.6\text{ V}$  (unless otherwise noted)

PARAMETER		TEST CONDITIONS	MIN	TYP	MAX	UNIT
$V_{\text{IN(REGIN)}}$	REGIN pin voltage measurement range		2.45		4.5	V
$t_{\text{ADC_CONV}}$	Conversion time			125		ms
	Effective resolution			15		bits

## 6.10 Integrating ADC (Coulomb Counter) Characteristics

 $T_A = -40^{\circ}\text{C}$  to  $85^{\circ}\text{C}$ ; typical values at  $T_A = 30^{\circ}\text{C}$  and  $V_{\text{REGIN}} = 3.6\text{ V}$  (unless otherwise noted)

PARAMETER		TEST CONDITIONS	MIN	TYP	MAX	UNIT
$V_{\text{SRCM}}$	Input voltage range of SRN, SRP pins		VSS		$V_{\text{REGIN}} + 100\text{ mV}$	V

## Integrating ADC (Coulomb Counter) Characteristics (continued)

 $T_A = -40^{\circ}\text{C}$  to  $85^{\circ}\text{C}$ ; typical values at  $T_A = 30^{\circ}\text{C}$  and  $V_{\text{REGIN}} = 3.6\text{ V}$  (unless otherwise noted)

PARAMETER	TEST CONDITIONS	MIN	TYP	MAX	UNIT
$V_{\text{SRDM}}$	Input differential voltage range of $V_{\text{SRP}}-V_{\text{SRN}}$		$\pm 80$		mV
$t_{\text{SR\_CONV}}$	Conversion time	Single conversion	1		s
	Effective Resolution	Single conversion	16		bits

### 6.11 I<sup>2</sup>C-Compatible Interface Communication Timing

 $T_A = -40^{\circ}\text{C}$  to  $85^{\circ}\text{C}$ ; typical values at  $T_A = 30^{\circ}\text{C}$  and  $V_{\text{REGIN}} = 3.6\text{ V}$  (unless otherwise noted)

		MIN	NOM	MAX	UNIT
<b>Standard Mode (100 kHz)</b>					
$t_{\text{d(STA)}}$	Start to first falling edge of SCL	4			$\mu\text{s}$
$t_{\text{w(L)}}$	SCL pulse duration (low)	4.7			$\mu\text{s}$
$t_{\text{w(H)}}$	SCL pulse duration (high)	4			$\mu\text{s}$
$t_{\text{su(STA)}}$	Setup for repeated start	4.7			$\mu\text{s}$
$t_{\text{su(DAT)}}$	Data setup time	Host drives SDA	250		ns
$t_{\text{h(DAT)}}$	Data hold time	Host drives SDA	0		ns
$t_{\text{su(STOP)}}$	Setup time for stop	4			$\mu\text{s}$
$t_{\text{(BUF)}}$	Bus free time between stop and start	Includes Command Waiting Time	66		$\mu\text{s}$
$t_{\text{f}}$	SCL or SDA fall time <sup>(1)(2)</sup>			300	ns
$t_{\text{r}}$	SCL or SDA rise time <sup>(1)(2)</sup>			300	ns
$f_{\text{SCL}}$	Clock frequency <sup>(3)</sup>			100	kHz
<b>Fast Mode (400 kHz)</b>					
$t_{\text{d(STA)}}$	Start to first falling edge of SCL	600			ns
$t_{\text{w(L)}}$	SCL pulse duration (low)	1300			ns
$t_{\text{w(H)}}$	SCL pulse duration (high)	600			ns
$t_{\text{su(STA)}}$	Setup for repeated start	600			ns
$t_{\text{su(DAT)}}$	Data setup time	Host drives SDA	100		ns
$t_{\text{h(DAT)}}$	Data hold time	Host drives SDA	0		ns
$t_{\text{su(STOP)}}$	Setup time for stop	600			ns
$t_{\text{(BUF)}}$	Bus free time between stop and start	Includes Command Waiting Time	66		$\mu\text{s}$
$t_{\text{f}}$	SCL or SDA fall time <sup>(1)(2)</sup>			300	ns
$t_{\text{r}}$	SCL or SDA rise time <sup>(1)(2)</sup>			300	ns
$f_{\text{SCL}}$	Clock frequency <sup>(3)</sup>			400	kHz

(1) Specified by design. Not production tested.

(2) Bus capacitance and pull-up resistance impact rise and fall times. View the rise and fall times to assist with debugging.

(3) If the clock frequency ( $f_{\text{SCL}}$ ) is  $> 100\text{ kHz}$ , use 1-byte write commands for proper operation. All other transactions types are supported at 400 kHz. (See [I<sup>2</sup>C Interface](#) and [I<sup>2</sup>C Command Waiting Time](#).)

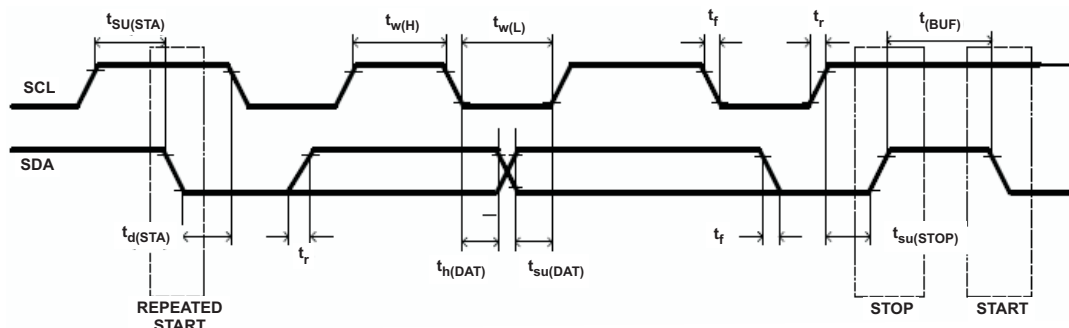
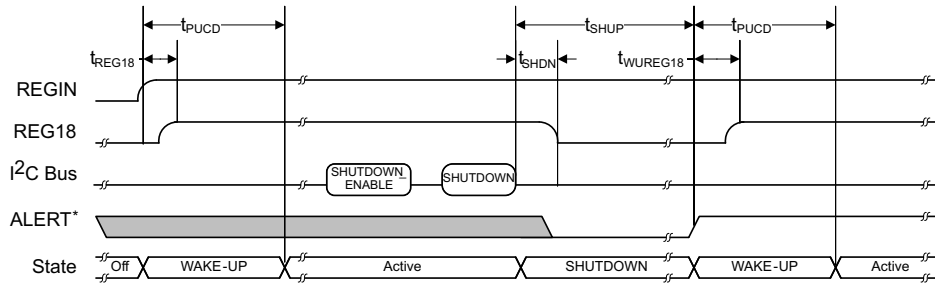

Figure 1. I<sup>2</sup>C-Compatible Interface Timing Diagrams

### 6.12 SHUTDOWN and WAKE-UP Timing



\* ALERT is configured as an input for wake-up signaling

**Figure 2. SHUTDOWN and WAKE-UP Timing Diagram**

### 6.13 Typical Characteristics

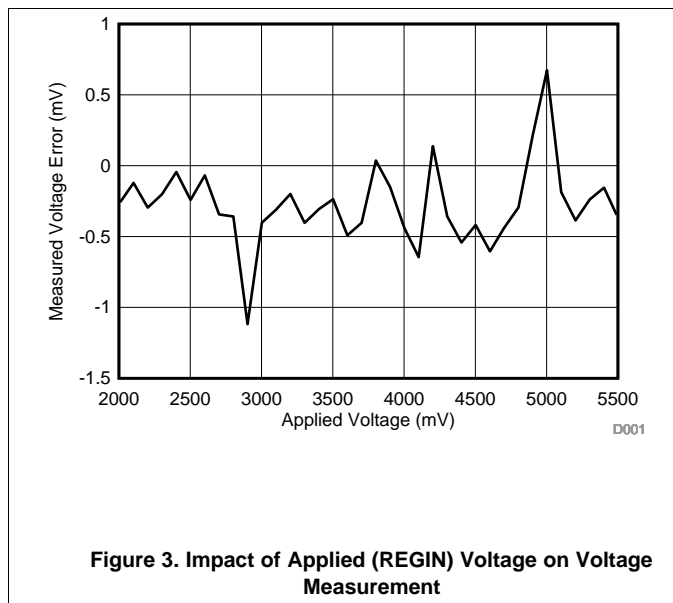

**Figure 3. Impact of Applied (REGIN) Voltage on Voltage Measurement**

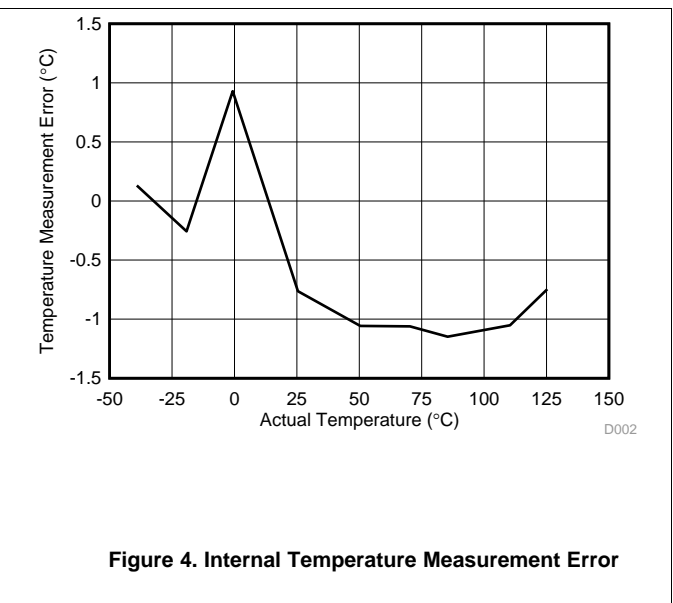

**Figure 4. Internal Temperature Measurement Error**

## 7 Detailed Description

### 7.1 Overview

The bq34210-Q1 incorporates fuel gauging and an End-of-Service (EOS) Determination function for use in 1-series cell packs with support for multiple battery chemistries, including Lithium-Ion (Li-Ion), Lithium Iron Phosphate (LiFePO<sub>4</sub>), and Nickel Metal Hydride (NiMH). The gas gauging function uses Compensated End-of-Discharge Voltage (CEDV) technology to accurately predict the battery capacity and other operational characteristics of the battery, and can be interrogated by a host processor to provide cell information, such as remaining capacity, full charge capacity, and average current.

See the *bq34210-Q1 Technical Reference Manual* (TRM, [SLUUBE8](#)) for further details.

#### NOTE

The following formatting conventions are used in this document:

**Commands:** *italics* with parentheses() and no breaking spaces, for example, *Control()*.

**Data Flash:** *italics*, **bold**, and breaking spaces, for example, ***Design Capacity***.

**Register bits and flags:** *italics* with brackets [ ], for example, [*TDA*]

**Data flash bits:** *italics*, **bold**, and brackets [ ], for example, [***LED1***]

**Modes and states:** ALL CAPITALS, for example, UNSEALED mode.

### 7.2 Functional Block Diagram

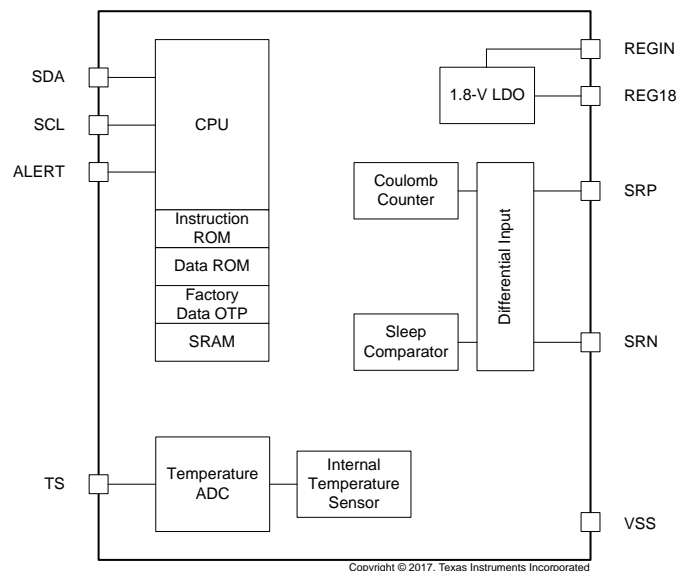

### 7.3 Feature Description

Information is accessed through a series of commands called *Standard Commands*. The *Extended Commands* set provides additional capabilities. Both sets of commands, indicated by the general format *Command()*, are used to read and write information in the control and status registers, as well as its data locations. Commands are sent from the system to the gauge via the I<sup>2</sup>C serial communications engine, and can be executed during application development, system manufacture, or end-equipment operation.



## Feature Description (continued)

The integrated End-of-Service (EOS) Determination function is specifically intended for applications where the battery is rarely discharged, such as in eCall systems, uninterruptible power supplies (UPS), enterprise server backup systems, and telecommunications backup modules. In such systems, the battery may remain in a fully (or near-fully) charged state for much of its lifetime, with it rarely or never undergoing a significant discharge. If the health of the battery in such a system is not monitored regularly, then it may degrade beyond the level required for a system backup/discharge event, and thus fail precisely at the time when it is needed most.

The EOS Determination function monitors the health of the battery through the use of infrequent learning phases, which involve a controlled discharge of ~1% capacity, and provides an alert to the system when the battery is approaching the end of its usable service. By coordinating battery charging with the learning phases, the battery capacity available to the system can be maintained above a preselected level, which helps to avoid compromising the battery's ability to support a system discharge event.

---

### NOTE

The following sections offer a brief overview of the content available in the *bq34210-Q1 Technical Reference Manual* (TRM, [SLUUBE8](#)), and should be used only as references to the respective sections in the TRM for full details.

---

### 7.3.1 Device Configuration

The device must select the correct CEDV profile, interrupt functions (enables, levels), and more during its initial configuration setup. The bq34210-Q1 includes two CEDV profiles (XYZ and ABC), which are stored in ROM. If neither of these profiles matches the battery used, a new configuration must be stored in RAM using Texas Instruments tools (see [Getting Started](#) for more details). Changing batteries also requires a new initialization of the configuration settings. This enables the device to be reconfigured for different battery chemistries or capacities through the host. If another battery is chosen, the parameters must be generated using TI's web-based tool, Gauge Parameter Calculator for CEDV Gauges ([GAUGEPARCAL](#)). The *bq34210-Q1 TRM* provides further details.

### 7.3.2 ALERT Interrupt and SHUTDOWN Wake-up

The interrupt function of the ALERT pin enables the bq34210-Q1 to communicate with the main system.

Even if the host is not using the ALERT functionality, it is recommended that ALERT be connected to a GPIO of the host so that in cases where the device is in SHUTDOWN, toggling ALERT can wake up the gauge from the SHUTDOWN state.

### 7.3.3 Voltage Measurement and Calibration

Voltage measurements and calibration are done automatically. The Battery Management Studio [bqStudio](#) tool aids in setting up this function to match system requirements.

### 7.3.4 Temperature Measurement

The device can be configured to use an external thermistor (103AT type) to measure temperature or use its internal temperature sensor.

### 7.3.5 Charging and Termination

The bq34210-Q1 monitors charging and detects termination. The termination works for Li-Ion, LiFePO<sub>4</sub>, and NiMH systems.

### 7.3.6 Accumulated Charge Measurement

The device measures the accumulated charge and reports the duration over which that charge was accumulated. The *AccumulatedCharge()* and *AccumulatedChargeTime()* registers can be used to send an alert to the host when a certain threshold is achieved.

## Feature Description (continued)

### 7.3.7 Gas Gauging

The bq34210-Q1 device features the Compensated End-of-Discharge Voltage (CEDV) gauging algorithm. This algorithm uses the accumulated measured quantities for charge and discharge in addition to estimating self-discharge of the battery. Registers including Remaining Capacity, Design Capacity, Full Charge Capacity, and Discharge Count Register (DCR) are used in this algorithm.

### 7.3.8 Battery Condition Warnings

Battery status indications are stored in registers and are used by the device to take action and provide warnings. Examples of indicator parameters are state-of-charge low detection, overtemperature-in-charge, and battery voltage high/low.

### 7.3.9 Configuration Update

CONFIG UPDATE mode is used when updating the configuration data of the fuel gauge. Gauging is disabled during this mode. This is required when a new battery is inserted.

### 7.3.10 End-Of-Service Determination

The bq34210-Q1 device incorporates the End-of-Service (EOS) Determination function to calculate the end of useful service of the battery and to provide alerts based on this detection. Learning phases are used to gather information about the present state of the battery through its cell resistance.

### 7.3.11 Battery Level Threshold

The Battery Level Threshold (BLT) feature indicates when the SOC of a battery pack has depleted to a certain value stored in a register. The thresholds can be set for the charge and discharge conditions.

### 7.3.12 Communications

#### 7.3.12.1 I<sup>2</sup>C Interface

The slave-only fuel gauge supports the standard I<sup>2</sup>C read, incremental read, quick read, one-byte write, and incremental write functions. The 7-bit device address (ADDR) is the most significant 7 bits of the hex address and is fixed as 1010101. The first 8 bits of the I<sup>2</sup>C protocol are, therefore, 0xAA or 0xAB for write or read, respectively.

#### 7.3.12.2 I<sup>2</sup>C Time Out

The I<sup>2</sup>C engine releases SDA and SCL if the I<sup>2</sup>C bus is held low for 2 seconds. If the fuel gauge is holding the lines, releasing them frees them for the master to drive the lines. If an external condition is holding either of the lines low, the I<sup>2</sup>C engine enters the low-power SLEEP mode.

#### 7.3.12.3 I<sup>2</sup>C Command Waiting Time

To ensure proper operation at 400 kHz, a  $t_{(BUF)} \geq 66 \mu\text{s}$  bus-free waiting time must be inserted between all packets addressed to the fuel gauge. In addition, if the SCL clock frequency ( $f_{SCL}$ ) is  $> 100 \text{ kHz}$ , use individual 1-byte write commands for proper data flow control.

#### 7.3.12.4 I<sup>2</sup>C Clock Stretching

A clock stretch can occur during all modes of fuel gauge operation. In SLEEP mode, a short  $\leq 100\text{-}\mu\text{s}$  clock stretch occurs on all I<sup>2</sup>C traffic as the device must wake up to process the packet. In the other modes (INITIALIZATION, NORMAL), a  $\leq 4\text{-ms}$  clock stretching period may occur within packets addressed for the fuel gauge as the I<sup>2</sup>C interface performs normal data flow control.

### 7.3.13 Additional Data Memory Parameter Descriptions

The calibration method requires a correction due to offset errors, using a number of samples to get a statistical average for the golden image.

## 7.4 Device Functional Modes

To minimize power consumption, the fuel gauge has four power modes:

- INITIALIZATION
- NORMAL
- SLEEP
- SHUTDOWN

The fuel gauge passes automatically between these modes, depending upon the occurrence of specific events, though a system processor can initiate some of these modes directly. The *bq34210-Q1 Technical Reference Manual (SLUUBE8)* provides more details.

### 7.4.1 INITIALIZATION Mode

The bq34210-Q1 enters INITIALIZATION mode at power up. This mode prepares the device to enter NORMAL mode through its internal power-on reset sequence. When the reset sequence is complete, the device automatically moves to NORMAL mode.

### 7.4.2 NORMAL Mode

The bq34210 NORMAL mode is entered from INITIALIZATION mode when the power-on reset is complete. When the charge and discharge currents are above the programmable level, the device will remain in NORMAL mode. If the measured currents are below the programmable level, SLEEP mode is entered. Once the currents increase above the threshold, the device will reenter NORMAL mode. The device will enter SHUTDOWN mode through a command sequence.

### 7.4.3 SLEEP Mode

SLEEP mode is entered from NORMAL mode if enabled and the current is below a programmable level. Once the current increases above that level, NORMAL mode is reentered.

### 7.4.4 SHUTDOWN Mode

The lowest power mode is SHUTDOWN mode. In this mode, the device is completely off. It is entered through an I<sup>2</sup>C command. Exiting from SHUTDOWN mode can be done by battery removal and replacement or through the ALERT pin. Pulling ALERT low for  $t_{SHUP}$  and then above  $V_{IH(OD)}$  enables the bq34210 device to go through its standard power-up sequence (into INITIALIZATION mode).

## 8 Application and Implementation

### NOTE

Information in the following application section is not part of the TI component specification, and TI does not warrant its accuracy or completeness. TI's customers are responsible for determining suitability of components for their purposes. Customers should validate and test their design implementation to confirm system functionality.

### 8.1 Application Information

The bq34210-Q1 fuel gauge is a microcontroller peripheral that provides system-side fuel gauging for 1-series cell batteries of a variety of chemistries. Battery fuel gauging with the fuel gauge requires connections only to PACK+ and PACK– for a removable battery pack or embedded battery circuit. To allow for optimal performance in the end application, special considerations must be taken to ensure minimization of measurement error through proper printed circuit board (PCB) board layout. Such requirements are detailed in [Design Requirements](#).

#### 8.1.1 Getting Started

To help configure and evaluate a bq34210-Q1 solution, Texas Instruments provides many supporting tools on the [TI.com](#) website, including the following:

- Battery Management Studio ([bqStudio](#))
- Gauge Parameter Calculator for CEDV Gauges ([GAUGEPARCAL](#))
- [bqProduction](#) to assist with the manufacturing process

These tools work with a TI EVM and with a self-designed solution. The [bq34210-Q1 Technical Reference Manual \(SLUUBE8\)](#) provides details on programming the gauge.

### 8.2 Typical Applications

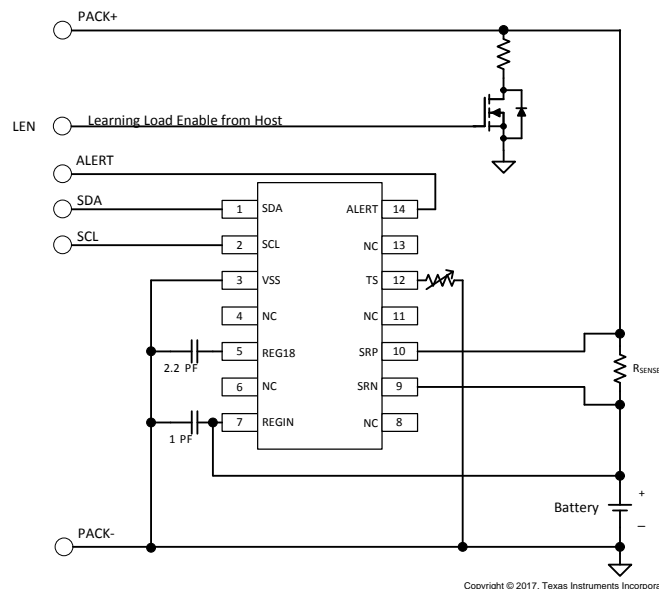

Figure 5. Typical Application

#### 8.2.1 Design Requirements

This design, for example, is for an automotive eCall solution. Calculate the required battery capacity by taking into account the required talk and standby time while in battery backup. Assume 10 minutes for a call followed by a 60-minute idle time (while pinging still occurs), and finally an additional 10-minute call. Understand the typical aging characteristics of the battery to know when the remaining capacity still fulfills the required capacity calculated previously. If the calculations show the requirement for a 1-Ah battery, a reasonable capacity battery to use would be 20% larger, or 1.2 mAh.

## Typical Applications (continued)

### 8.2.2 Detailed Design Procedure

#### 8.2.2.1 REGIN Voltage Sense Input

A ceramic capacitor at the input to the REGIN pin is used to bypass AC voltage ripple to ground, greatly reducing its influence on battery voltage measurements.

#### 8.2.2.2 Integrated LDO Capacitor

The fuel gauge has an integrated LDO with an output on the REG18 pin of approximately 1.8 V. A capacitor of at least a 2.2- $\mu$ F value should be connected between the REG18 pin and VSS. The capacitor must be placed close to the fuel gauge and have short traces to both the REG18 pin and VSS. This regulator must not be used to provide power for other devices in the system.

#### 8.2.2.3 Sense Resistor Selection

Any variation encountered in the resistance present between the SRP and SRN pins of the fuel gauge will affect the resulting differential voltage and derived current it senses. As such, it is recommended to select a sense resistor with minimal tolerance and temperature coefficient of resistance (TCR) characteristics. The standard recommendation based on best compromise between performance and price is a 1% tolerance, 50-ppm drift sense resistor with a 1-W power rating. The power rating must be consistent with the maximum current and sense resistor value. The bq34210-Q1 device supports sense resistors from 5 m $\Omega$  to 20 m $\Omega$ .

### 8.2.3 External Thermistor Support

The fuel gauge temperature sensing circuitry is designed to work with a negative temperature coefficient-type (NTC) thermistor with a characteristic 10-k $\Omega$  resistance at room temperature (25°C). The default curve-fitting coefficients configured in the fuel gauge specifically assume a Semitec 103AT type thermistor profile and so that is the default recommendation for thermistor selection purposes. Moving to a separate thermistor resistance profile (for example, JT-2 or others) requires an update to the default thermistor coefficients, which can be modified in RAM to ensure highest accuracy temperature measurement performance. For more details, see the *Temperature Measurement* section of the bq34210-Q1 TRM ([SLUUBE8](#)).

### 8.2.4 Learning Load Enable (LEN) from Host

The learning load helps to determine the status of the battery (EOS). The host must control the load during the learning phase and put the bq34210-Q1 gauge into the learning phase. The resistance is set by selecting the learning current. With 220 mA and the charge voltage of 4.2 V, use Ohm's law to calculate the resistance (19.09  $\Omega$ ).

### 8.2.5 I<sup>2</sup>C

If the external pullup resistors on the SCL and SDA lines will be disconnected from the host during low-power operation, it is recommended to use external 1-M $\Omega$  pulldown resistors to VSS to avoid floating inputs to the I<sup>2</sup>C engine.

The value of the SCL and SDA pullup resistors should take into consideration the pullup voltage and the bus capacitance along with the communication speed. Many communication errors are a result of improper sizing of the resistors. Rounding of the clock and data signals indicated improper RC configurations. The maximum pullup resistance ( $R_{PUmax}$ ) can be estimated by this equation:

$$R_{PUmax} = t_r / (0.4873 \times C_{BUS})$$

Where  $t_r$  is the rise time and  $C_{BUS}$  is the total bus capacitance.

Assuming a bus capacitance of 10 pF, [Table 1](#) shows some recommended values.

**Table 1. Recommended Values for SCL and SDA Pullup Resistors**

VPU	1.8 V		3.3 V	
	Range	Typical	Range	Typical
$R_{PU}$	$400 \Omega \leq R_{PU} \leq 37.6 \text{ k}\Omega$	10 k $\Omega$	$900 \Omega \leq R_{PU} \leq 29.2 \text{ k}\Omega$	5.1 k $\Omega$

### 8.2.6 Temperature Sense

The TS pin is used to measure the system temperature.

If the battery pack thermistor is not connected to the TS pin, the TS pin should be pulled down to VSS with a 10-kΩ resistor. The TS pin must not be shorted directly any other pin.

### 8.2.7 Application Curves

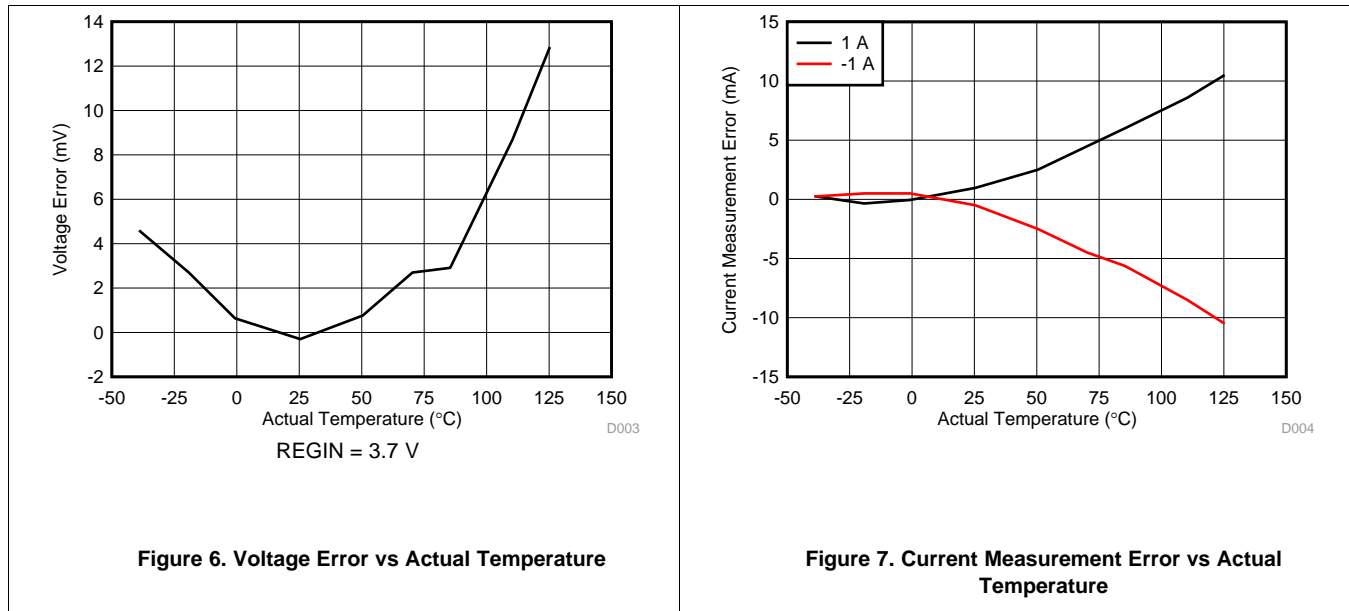

## 9 Power Supply Recommendation

### 9.1 Power Supply Decoupling

The battery connection on the REGIN pin is used for two purposes:

- To supply power to the fuel gauge and
- To provide an input for voltage measurement of the battery.

A capacitor of value of at least 1 μF should be connected between REGIN and VSS. Place the capacitor close to the fuel gauge and have short traces to the REGIN pin and VSS.

The fuel gauge has an integrated LDO with an output on the REG18 pin of approximately 1.8 V. A capacitor of value at least 2.2 μF should be connected between the REG18 pin and VSS. Place the capacitor close to the fuel gauge and have short traces to both the REG18 pin and VSS. This regulator must not be used to provide power for other devices in the system.

## 10 Layout

### 10.1 Layout Guidelines

- A capacitor of a value of at least 2.2  $\mu\text{F}$  is connected between the REG18 pin and VSS. The capacitor should be placed close to the fuel gauge and have short traces to both the REG18 pin and VSS as shown in [bq34210-Q1 Capacitor Layout](#). This regulator must not be used to provide power for other devices in the system.
- If the connection between the battery pack and the gauge RGIN pin has the potential to pick up noise, it is required to have a capacitor of at least 1.0  $\mu\text{F}$  connect between the RGIN pin and VSS. Place the capacitor close to the fuel gauge and have short traces to both the RGIN pin and VSS.
- The SRP and SRN pins should be Kelvin connected to the  $R_{\text{SENSE}}$  terminals.
- For the low-side sense resistor:
  - Connect SRP to the battery pack side of  $R_{\text{SENSE}}$  and SRN to the system side of the  $R_{\text{SENSE}}$ , as shown in [bq34210-Q1 Sense Resistor Layout](#).
  - Kelvin connect the RGIN pin to the battery PACK+ terminal.

### 10.2 Layout Example

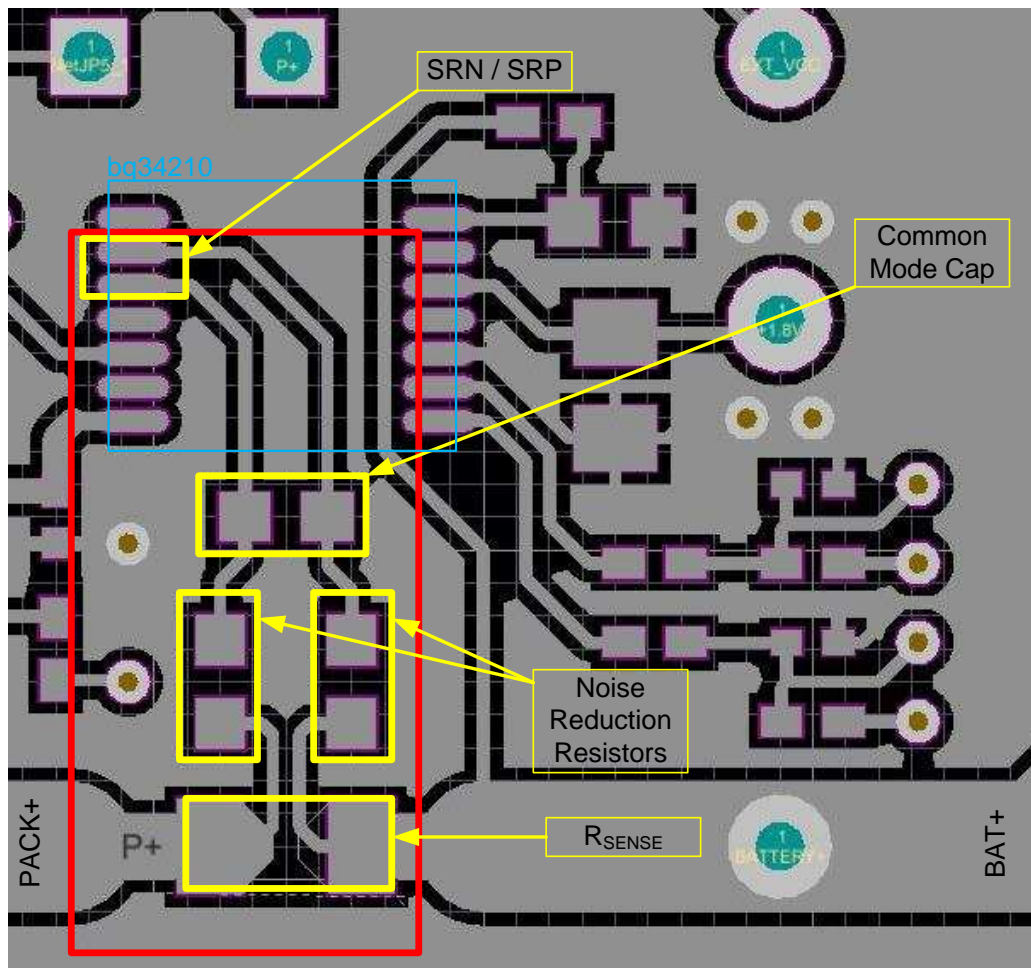

Figure 8. bq34210-Q1 Sense Resistor Layout

Layout Example (continued)

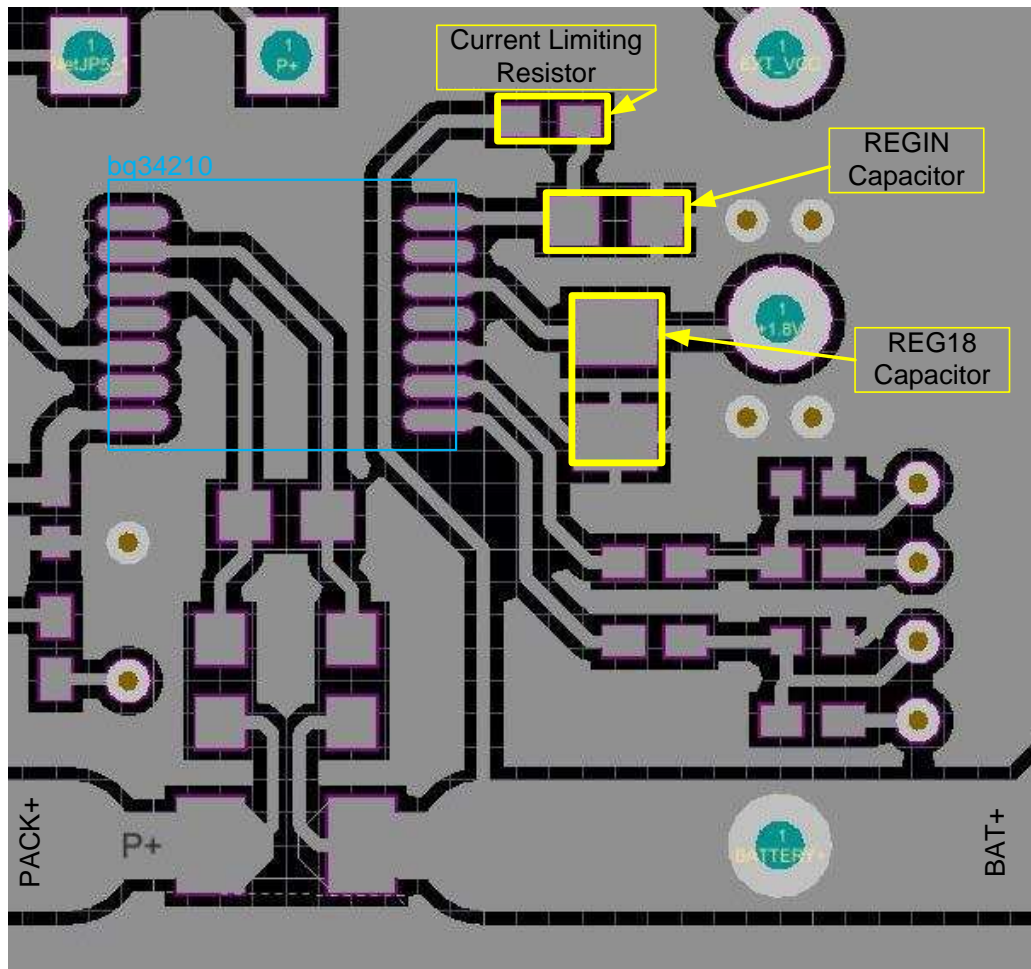

Figure 9. bq34210-Q1 Capacitor Layout



## 11 Device and Documentation Support

### 11.1 Device Support

#### 11.1.1 Tools

- Battery Management Studio ([bqStudio](#))
- Gauge Parameter Calculator for CEDV Gauges ([GAUGEPARCAL](#))
- [bqProduction](#) to assist with the manufacturing process

### 11.2 Documentation Support

#### 11.2.1 Related Documentation

- [bq34210-Q1 Technical Reference Manual \(SLUUBE8\)](#)
- [Single Cell Gas Gauge Circuit Design \(SLUA456\)](#)
- [ESD and RF Mitigation in Handheld Battery Electronics \(SLUA460\)](#)

### 11.3 Community Resources

The following links connect to TI community resources. Linked contents are provided "AS IS" by the respective contributors. They do not constitute TI specifications and do not necessarily reflect TI's views; see TI's [Terms of Use](#).

**TI E2E™ Online Community** *TI's Engineer-to-Engineer (E2E) Community*. Created to foster collaboration among engineers. At [e2e.ti.com](http://e2e.ti.com), you can ask questions, share knowledge, explore ideas and help solve problems with fellow engineers.

**Design Support** *TI's Design Support* Quickly find helpful E2E forums along with design support tools and contact information for technical support.

### 11.4 Trademarks

E2E is a trademark of Texas Instruments.

l<sup>2</sup>C is a trademark of NXP Semiconductors N.V.

All other trademarks are the property of their respective owners.

### 11.5 Electrostatic Discharge Caution



This integrated circuit can be damaged by ESD. Texas Instruments recommends that all integrated circuits be handled with appropriate precautions. Failure to observe proper handling and installation procedures can cause damage.

ESD damage can range from subtle performance degradation to complete device failure. Precision integrated circuits may be more susceptible to damage because very small parametric changes could cause the device not to meet its published specifications.

### 11.6 Glossary

[SLYZ022](#) — *TI Glossary*.

This glossary lists and explains terms, acronyms, and definitions.

## 12 Mechanical, Packaging, and Orderable Information

The following pages include mechanical, packaging, and orderable information. This information is the most current data available for the designated devices. This data is subject to change without notice and revision of this document. For browser-based versions of this data sheet, refer to the left-hand navigation.

## PACKAGING INFORMATION

Orderable Device	Status (1)	Package Type	Package Drawing	Pins	Package Qty	Eco Plan (2)	Lead finish/ Ball material (6)	MSL Peak Temp (3)	Op Temp (°C)	Device Marking (4/5)	Samples
BQ34210IPWRQ1	ACTIVE	TSSOP	PW	14	2000	RoHS & Green	NIPDAU	Level-3-260C-168 HR	-40 to 85	BQ34210I	Samples

(1) The marketing status values are defined as follows:

**ACTIVE:** Product device recommended for new designs.

**LIFEBUY:** TI has announced that the device will be discontinued, and a lifetime-buy period is in effect.

**NRND:** Not recommended for new designs. Device is in production to support existing customers, but TI does not recommend using this part in a new design.

**PREVIEW:** Device has been announced but is not in production. Samples may or may not be available.

**OBSOLETE:** TI has discontinued the production of the device.

(2) **RoHS:** TI defines "RoHS" to mean semiconductor products that are compliant with the current EU RoHS requirements for all 10 RoHS substances, including the requirement that RoHS substance do not exceed 0.1% by weight in homogeneous materials. Where designed to be soldered at high temperatures, "RoHS" products are suitable for use in specified lead-free processes. TI may reference these types of products as "Pb-Free".

**RoHS Exempt:** TI defines "RoHS Exempt" to mean products that contain lead but are compliant with EU RoHS pursuant to a specific EU RoHS exemption.

**Green:** TI defines "Green" to mean the content of Chlorine (Cl) and Bromine (Br) based flame retardants meet JS709B low halogen requirements of <=1000ppm threshold. Antimony trioxide based flame retardants must also meet the <=1000ppm threshold requirement.

(3) MSL, Peak Temp. - The Moisture Sensitivity Level rating according to the JEDEC industry standard classifications, and peak solder temperature.

(4) There may be additional marking, which relates to the logo, the lot trace code information, or the environmental category on the device.

(5) Multiple Device Markings will be inside parentheses. Only one Device Marking contained in parentheses and separated by a "-" will appear on a device. If a line is indented then it is a continuation of the previous line and the two combined represent the entire Device Marking for that device.

(6) Lead finish/Ball material - Orderable Devices may have multiple material finish options. Finish options are separated by a vertical ruled line. Lead finish/Ball material values may wrap to two lines if the finish value exceeds the maximum column width.

**Important Information and Disclaimer:** The information provided on this page represents TI's knowledge and belief as of the date that it is provided. TI bases its knowledge and belief on information provided by third parties, and makes no representation or warranty as to the accuracy of such information. Efforts are underway to better integrate information from third parties. TI has taken and continues to take reasonable steps to provide representative and accurate information but may not have conducted destructive testing or chemical analysis on incoming materials and chemicals. TI and TI suppliers consider certain information to be proprietary, and thus CAS numbers and other limited information may not be available for release.

In no event shall TI's liability arising out of such information exceed the total purchase price of the TI part(s) at issue in this document sold by TI to Customer on an annual basis.

**TAPE AND REEL INFORMATION**

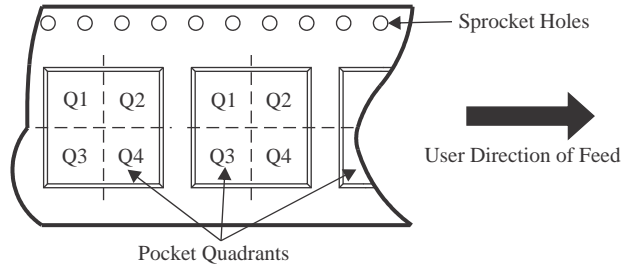
**QUADRANT ASSIGNMENTS FOR PIN 1 ORIENTATION IN TAPE**

\*All dimensions are nominal

Device	Package Type	Package Drawing	Pins	SPQ	Reel Diameter (mm)	Reel Width W1 (mm)	A0 (mm)	B0 (mm)	K0 (mm)	P1 (mm)	W (mm)	Pin1 Quadrant
BQ34210IPWRQ1	TSSOP	PW	14	2000	330.0	12.4	6.9	5.6	1.6	8.0	12.0	Q1

**TAPE AND REEL BOX DIMENSIONS**

\*All dimensions are nominal

Device	Package Type	Package Drawing	Pins	SPQ	Length (mm)	Width (mm)	Height (mm)
BQ34210IPWRQ1	TSSOP	PW	14	2000	350.0	350.0	43.0

PW (R-PDSO-G14)

PLASTIC SMALL OUTLINE



4040064-3/G 02/11

- NOTES:
- A. All linear dimensions are in millimeters. Dimensioning and tolerancing per ASME Y14.5M-1994.
  - B. This drawing is subject to change without notice.
  - C. Body length does not include mold flash, protrusions, or gate burrs. Mold flash, protrusions, or gate burrs shall not exceed 0,15 each side.
  - D. Body width does not include interlead flash. Interlead flash shall not exceed 0,25 each side.
  - E. Falls within JEDEC MO-153

## IMPORTANT NOTICE AND DISCLAIMER

TI PROVIDES TECHNICAL AND RELIABILITY DATA (INCLUDING DATA SHEETS), DESIGN RESOURCES (INCLUDING REFERENCE DESIGNS), APPLICATION OR OTHER DESIGN ADVICE, WEB TOOLS, SAFETY INFORMATION, AND OTHER RESOURCES "AS IS" AND WITH ALL FAULTS, AND DISCLAIMS ALL WARRANTIES, EXPRESS AND IMPLIED, INCLUDING WITHOUT LIMITATION ANY IMPLIED WARRANTIES OF MERCHANTABILITY, FITNESS FOR A PARTICULAR PURPOSE OR NON-INFRINGEMENT OF THIRD PARTY INTELLECTUAL PROPERTY RIGHTS.

These resources are intended for skilled developers designing with TI products. You are solely responsible for (1) selecting the appropriate TI products for your application, (2) designing, validating and testing your application, and (3) ensuring your application meets applicable standards, and any other safety, security, regulatory or other requirements.

These resources are subject to change without notice. TI grants you permission to use these resources only for development of an application that uses the TI products described in the resource. Other reproduction and display of these resources is prohibited. No license is granted to any other TI intellectual property right or to any third party intellectual property right. TI disclaims responsibility for, and you will fully indemnify TI and its representatives against, any claims, damages, costs, losses, and liabilities arising out of your use of these resources.

TI's products are provided subject to [TI's Terms of Sale](#) or other applicable terms available either on [ti.com](https://www.ti.com) or provided in conjunction with such TI products. TI's provision of these resources does not expand or otherwise alter TI's applicable warranties or warranty disclaimers for TI products.

TI objects to and rejects any additional or different terms you may have proposed.

Mailing Address: Texas Instruments, Post Office Box 655303, Dallas, Texas 75265  
Copyright © 2024, Texas Instruments Incorporated