

DP83869HM High Immunity 10/100/1000 Ethernet Physical Layer Transceiver With Copper and Fiber Interface

1 Features

- Multiple operating modes
 - Media support: copper and fiber
 - Media conversion between copper and fiber
 - Bridge between RGMII and SGMII
- Maximum ambient temperature available of 125°C
- Exceeds 8kV IEC61000-4-2 ESD
- Low power consumption
 - < 150mW for 1000Base-X
 - < 500mW for 1000Base-T
- Low RGMII latency
 - Total latency ≤ 384ns for 1000Base-T
 - Total latency ≤ 361ns for 100Base-TX
- Time Sensitive Network (TSN) compliant
- Recovered clock output for SyncE
- Selectable synchronized clock output: 25MHz and 125MHz
- SFF-8431 V4.1, 1000BASE-X and 100BASE-FX Compatible
- IEEE1588 support via SFD
- Wake on LAN support
- Configurable IO voltages: 1.8V, 2.5V, and 3.3V
- SGMII, RGMII, MII MAC interface
- Jumbo frame support for 1000M and 100M speed
- Cable diagnostics
 - TDR
 - BIST
- Programmable RGMII termination impedance
- Integrated MDI termination resistor
- Fast link drop modes
- Conforms to IEEE 802.3 1000Base-T, 100Base-TX, 10Base-T, 1000Base-X, 100Base-FX

2 Applications

- [Industrial Factory Automation](#)
- [Grid Infrastructure](#)
- [Motor and Motion Control](#)
- [Test and Measurement](#)
- [Building Automation](#)
- [Real-Time Industrial Ethernet Applications such as ProfiNET®](#)

3 Description

The DP83869HM device is a robust, fully-featured gigabit physical layer (PHY) transceiver with integrated PMD sublayers that supports 10BASE-Te, 100BASE-TX and 1000BASE-T Ethernet protocols. The DP83869 also supports 1000BASE-X and 100BASE-FX fiber protocols. Optimized for ESD protection, the DP83869HM exceeds 8kV IEC 61000-4-2 (direct contact). This device interfaces to the MAC layer through reduced GMII (RGMII) and SGMII. In 100M mode, the device lets the designer use MII for lower latency. Programmable integrated termination impedance on RGMII/MII helps reduce system BOM.

The DP83869HM supports media conversion in unmanaged mode. In this mode, the DP83869HM can run 1000BASE-X-to-1000BASE-T and 100BASE-FX-to-100BASE-TX conversions.

The DP83869HM can also support bridge conversion from RGMII to SGMII and SGMII to RGMII. The DP83869HM is compliant to TSN standards and offers low latency.

The DP83869HM can also generate IEEE 1588 Sync Frame Detect indications to MAC. This can reduce the jitter in Time Synchronization and help the System account for asymmetric delays in Transmission and Reception of packets.

The standard Ethernet system block diagram is shown on the first page. Designers can also use the DP83869 in Media Converter mode, in RGMII-to-SGMII Bridge applications, and in SGMII-RGMII Bridge applications.

Package Information

PART NUMBER	PACKAGE ⁽¹⁾	PACKAGE SIZE ⁽²⁾
DP83869HM	RGZ (VQFN, 48)	7mm × 7mm
DP83867E/IS/CS	RGZ (VQFN, 48)	7mm × 7mm
DP83867IR/CR	RGZ (VQFN, 48)	7mm × 7mm

(1) For all available packages, see [Section 11](#).

(2) The package size (length × width) is a nominal value and includes pins, where applicable.



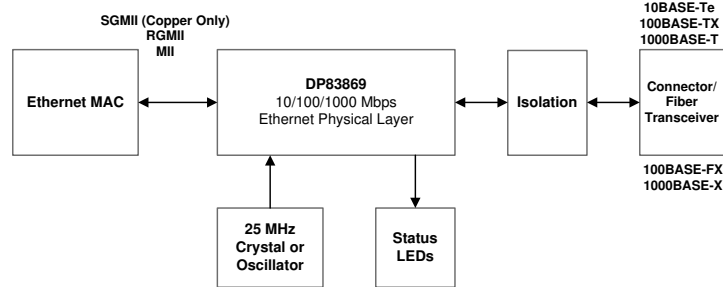

Standard Ethernet System Block Diagram

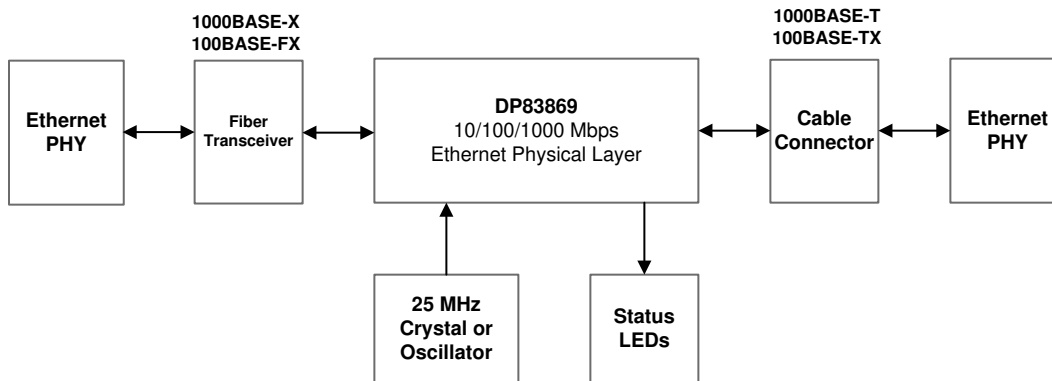

Figure 3-1. Media Converter System Block Diagram

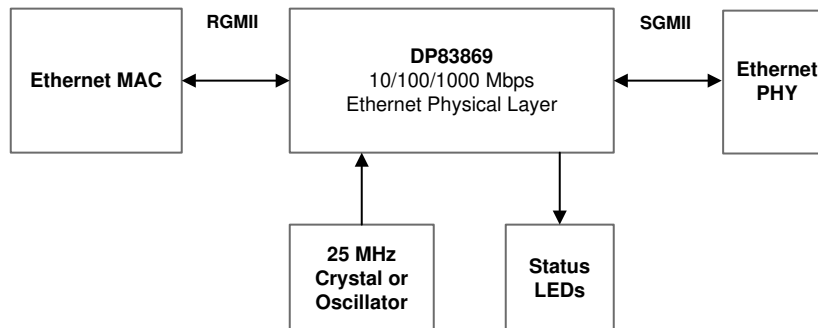

Figure 3-2. RGMII-SGMII Bridge System Block Diagram

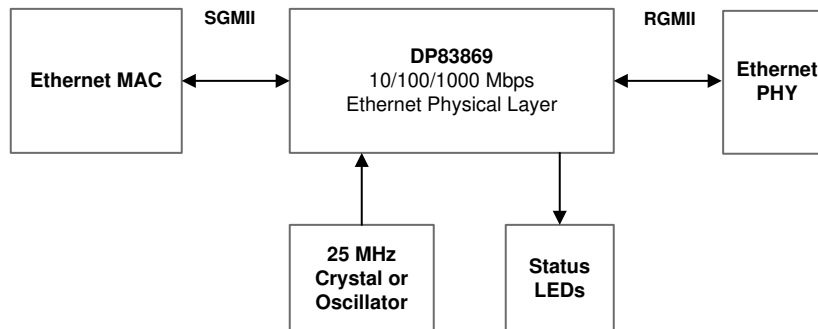

Figure 3-3. SGMII-RGMII Bridge System Block Diagram

Table of Contents

1 Features	1	7.4 Device Functional Modes	35
2 Applications	1	7.5 Programming	46
3 Description	1	7.6 Register Maps	53
4 Device Comparison	3	8 Application and Implementation	104
5 Pin Configuration and Functions	4	8.1 Application Information	104
6 Specifications	10	8.2 Typical Applications	104
6.1 Absolute Maximum Ratings.....	10	8.3 Power Supply Recommendations	109
6.2 ESD Ratings.....	10	8.4 Layout	113
6.3 Recommended Operating Conditions.....	10	9 Device and Documentation Support	118
6.4 Thermal Information.....	11	9.1 Documentation Support.....	118
6.5 Electrical Characteristics.....	11	9.2 Receiving Notification of Documentation Updates..	118
6.6 Timing Requirements.....	17	9.3 Support Resources.....	118
6.7 Timing Diagrams	20	9.4 Trademarks.....	118
6.8 Typical Characteristics.....	23	9.5 Electrostatic Discharge Caution.....	118
7 Detailed Description	24	9.6 Glossary.....	118
7.1 Overview.....	24	10 Revision History	118
7.2 Functional Block Diagram.....	25	11 Mechanical, Packaging, and Orderable Information	119
7.3 Feature Description.....	26		

4 Device Comparison

Table 4-1. Device Comparison

DEVICE	BRIDGE MODE	TEMPERATURE	TEMPERATURE GRADE
DP83869HM	Yes	-40°C to +125°C	High Temp

5 Pin Configuration and Functions

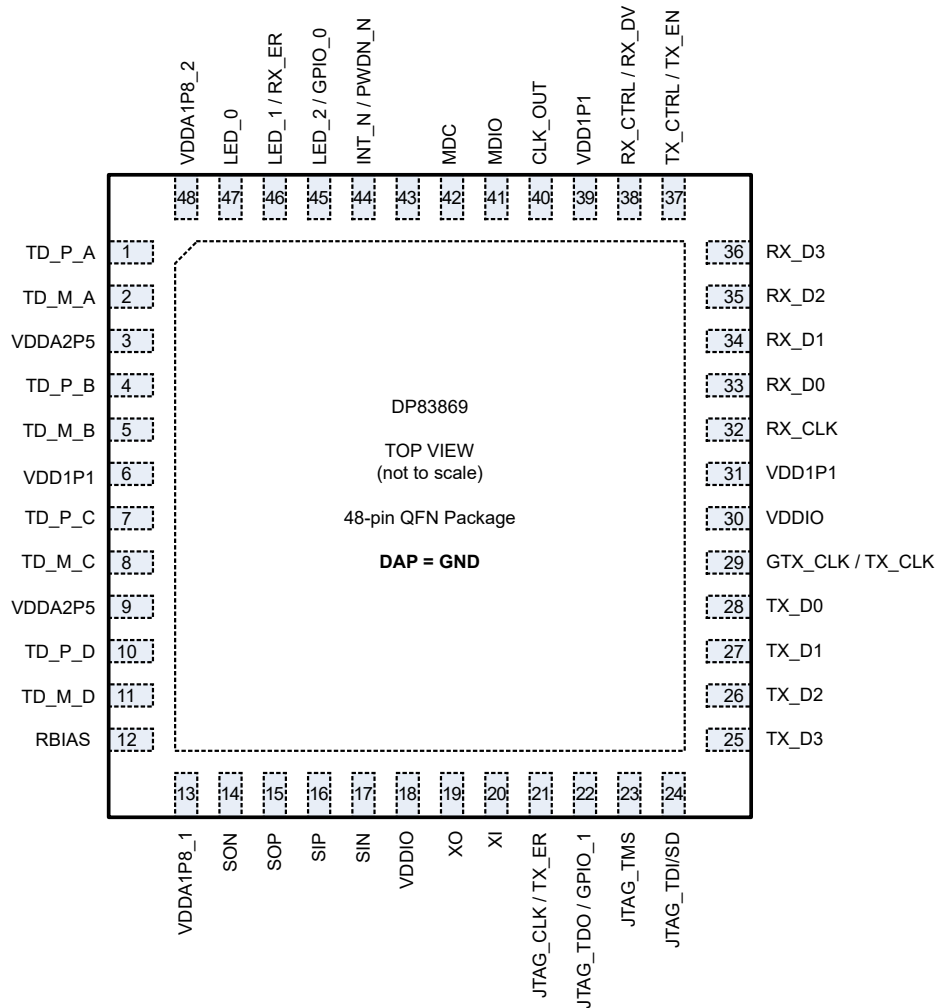

Figure 5-1. RGZ Package (48-Pin VQFN) Top View

Table 5-1. RGZ Package (VQFN) Pin Functions

PIN		I/O	TYPE	DESCRIPTION
NO.	NAME			
1	TD_P_A	I/O	Analog	Differential Transmit and Receive Signals
2	TD_M_A	I/O	Analog	Differential Transmit and Receive Signals
3	VDDA2P5	I	Power	2.5V Analog Supply (+/-5%). Each pin requires a 1µF and 0.1µF capacitor to GND.
4	TD_P_B	I/O	Analog	Differential Transmit and Receive Signals
5	TD_M_B	I/O	Analog	Differential Transmit and Receive Signals
6	VDD1P1	I	Power	1.1V Digital Supply (+/-10%). Each pin requires a 1µF and 0.1µF capacitor to GND.
7	TD_P_C	I/O	Analog	Differential Transmit and Receive Signals
8	TD_M_C	I/O	Analog	Differential Transmit and Receive Signals
9	VDDA2P5	I	Power	2.5V Analog Supply (+/-5%). Each pin requires a 1µF and 0.1µF capacitor to GND.
10	TD_P_D	I/O	Analog	Differential Transmit and Receive Signals
11	TD_M_D	I/O	Analog	Differential Transmit and Receive Signals
12	RBIAS	I	—	Bias Resistor Connection. An 11kΩ +/-1% resistor must be connected from RBIAS to GND.

Table 5-1. RGZ Package (VQFN) Pin Functions (continued)

PIN		I/O	TYPE	DESCRIPTION
NO.	NAME			
13	VDDA1P8_1	I	Power	No external supply is required for this pin in two-supply mode. When unused, no connections can be made to these pins. In three-supply mode, an external 1.8V(+/-5%) supply can be connected to these pins. When using an external supply, each pin requires a 1µF and 0.1µF capacitor to GND.
14	SON	O	Analog	Differential SGMII or Fiber Data Output: This signal carries data from the PHY to the MAC, fiber transceiver, or link partner in SGMII and fiber modes. This pin can be AC-coupled to the distant device through a 0.1µF capacitor. This pin provides LVDS signals, additional components may be required for the optical transceiver.
15	SOP	O	Analog	Differential SGMII or Fiber Data Output: This signal carries data from the PHY to the MAC, fiber transceiver, or link partner in SGMII and fiber modes. This pin should be AC-coupled to the distant device through a 0.1µF capacitor. This pin provides LVDS signals, additional components may be required for the optical transceiver
16	SIP	I	Analog	Differential SGMII or Fiber Data Input: This signal carries data from the MAC, fiber transceiver, or link partner, to the PHY in SGMII and fiber modes. This pin should be AC-coupled to the distant device through a 0.1µF capacitor. This pin accepts LVDS signals, additional components may be required for the optical transceiver
17	SIN	I	Analog	Differential SGMII or Fiber Data Input: This signal carries data from the MAC, fiber transceiver, or link partner, to the PHY in SGMII and fiber modes. This pin should be AC-coupled to the distant device through a 0.1µF capacitor. This pin accepts LVDS signals, additional components may be required for the optical transceiver
18	VDDIO	I	Power	I/O Power: 1.8V (±5%), 2.5V (±5%) or 3.3V (±5%). Each pin requires a 1µF and 0.1µF capacitor to GND
19	XO	O	Clock	CRYSTAL OSCILLATOR OUTPUT: Second terminal for 25MHz crystal. Must be left floating if a clock oscillator is used.
20	XI	I	Clock	CRYSTAL OSCILLATOR INPUT: 25MHz oscillator or crystal input.
21	JTAG_CLK/TX_ER	I	WPU	JTAG TEST CLOCK: IEEE 1149.1 Test Clock input, primary clock source for all test logic input and output controlled by the testing entity. MII Mode: In MII mode, this pin is configured as TX_ER pin and is sourced from MAC to PHY. Use of this pin is optional.
22	JTAG_TDO/GPIO_1	O	—	JTAG TEST DATA OUTPUT: IEEE 1149.1 Test Data Output pin, the most recent test results are scanned out of the device via TDO. General Purpose I/O: This signal provides a multi-function configurable I/O. Please refer to the GPIO_MUX_CTRL register for details.
23	JTAG_TMS	I	WPU	JTAG TEST MODE SELECT: IEEE 1149.1 Test Mode Select pin, the TMS pin sequences the Tap Controller (16-state FSM) to select the desired test instruction. TI recommends applying 3 clock cycles with JTAG_TMS high to reset the JTAG.
24	JTAG_TDI/SD	I	WPU	JTAG TEST DATA INPUT: IEEE 1149.1 Test Data Input pin, test data is scanned into the device via TDI. SD: In 1000Base-X and 100Base-FX mode, this pin acts as Signal Detect. This must be connected to Signal Detect of optical transceiver.
25	TX_D3	I	WPD	TRANSMIT DATA: Signal TX_D[3:0] carries data from the MAC to the PHY in RGMII mode and MII mode. Data is synchronous to the transmit clock. In RGMII mode GTX_CLK is the transmit clock and in MII mode TX_CLK is the transmit clock.
26	TX_D2	I	WPD	
27	TX_D1	I	WPD	
28	TX_D0	I	WPD	
29	GTX_CLK/TX_CLK	I/O	WPD	RGMII TRANSMIT CLOCK: This continuous clock signal is sourced from the MAC layer to the PHY. Nominal frequency is 125MHz in 1000Mbps mode. This pin is Input in RGMII mode. MII TRANSMIT CLOCK: In MII mode, this pin provides a 25MHz reference clock for 100Mbps speed and a 2.5MHz reference clock for 10Mbps speed. This pin is output in MII mode. This pin is GTX_CLK by default and can be changed to TX_CLK by register configurations.
30	VDDIO	I	Power	I/O Power: 1.8V (±5%), 2.5V (±5%) or 3.3V (±5%). Each pin requires a 1µF and 0.1µF capacitor to GND
31	VDD1P1	I	Power	1.1V Digital Supply (+/-10%). Each pin requires a 1µF and 0.1µF capacitor to GND.
32	RX_CLK	O	Strap, WPD	RECEIVE CLOCK: Provides the recovered receive clocks for different modes of operation: 125MHz in 1000Mbps RGMII mode.

Table 5-1. RGZ Package (VQFN) Pin Functions (continued)

PIN		I/O	TYPE	DESCRIPTION
NO.	NAME			
33	RX_D0	O	Strap, WPD	RECEIVE DATA: Signal RX_D[3:0] carries data from the PHY to the MAC in RGMII mode and in MII mode. Symbols received on the cable are decoded and presented on these pins synchronous to RX_CLK.
34	RX_D1	O	Strap, WPD	
35	RX_D2	O	Strap, WPD	
36	RX_D3	O	Strap, WPD	
37	TX_CTRL/TX_EN	I	WPD	TRANSMIT CONTROL: In RGMII mode, TX_CTRL combines the transmit enable and the transmit error signal inputs from the MAC using both clock edges. TX_EN: In MII mode, this pin functions as TX_EN.
38	RX_CTRL/RX_DV	O	WPD	RECEIVE CONTROL: In RGMII mode, the receive data available and receive error are combined (RXDV_ER) using both rising and falling edges of the receive clock (RX_CLK). RX_DV: In MII mode, this pin functions as RX_DV.
39	VDD1P1	I	Power	1.1V Digital Supply (+/-10%). Each pin requires a 1µF and 0.1µF capacitor to GND.
40	CLK_OUT	O	Clock	CLOCK OUTPUT: Output clock
41	MDIO	I/O	—	MANAGEMENT DATA I/O: Bi-directional management instruction/data signal that can be sourced by the management station or the PHY. This open-drain pin requires a 1.5kΩ pull-up resistor.
42	MDC	I	—	MANAGEMENT DATA CLOCK: Synchronous clock to the MDIO serial management input/output data. This clock can be asynchronous to the MAC transmit and receive clocks. The maximum clock rate is 25MHz. There is no minimum clock rate.
43	RESET_N	I	—	RESET_N: This pin is an active-low reset input that initializes or re-initializes all the internal registers of the DP83869. Asserting this pin low for at least 1µs will force a reset process to occur. It is in IO voltage domain. A 100Ω resistor and 47µF capacitor are required to be connected in series between RESET_N pin and Ground.
44	INT_N/PWDN_N	I/O	—	INTERRUPT / POWER DOWN: The default function of this pin is POWER DOWN. POWER DOWN: This is an Active Low Input. Asserting this signal low enables the power-down mode of operation. In this mode the device powers down and consumes minimum power. Register access is available through the Management Interface to configure and power up the device. INTERRUPT: The interrupt pin is an open-drain, active low output signal indicating an interrupt condition has occurred. Register access is required to determine which event caused the interrupt. TI recommends using an external 2.2kΩ resistor connected to the VDDIO supply. When register access is disabled through pin option, the interrupt is asserted for 500ms before self-clearing.
45	LED_2/GPIO_0	I/O	Strap, WPD	LED_2: Part of VIO voltage domain. General Purpose I/O: This signal provides a multi-function configurable I/O. Please refer to the GPIO_MUX_CTRL register for details.
46	LED_1/RX_ER	O	Strap, WPD	LED_1: Part of VIO voltage domain. MII Mode: In MII mode this pin is configured as RX_ER. This pin is asserted high synchronously to rising edge of RX_CLK. Use of this pin is optional.
47	LED_0	O	Strap, WPD	LED_0: This pin is part of the VDDIO voltage domain
48	VDDA1P8_2	I	Power	No external supply is required for this pin in two-supply mode. When unused, no connections can be made to these pins. In three-supply mode, an external 1.8V(+/-5%) supply can be connected to these pins. When using an external supply, each pin requires a 1µF and 0.1µF capacitor to GND.

Pin Functionality definitions are given below:

- I: Input
- O: Output
- I/O: Input/Output
- Strap: Multifunctional bootstrap pins
- WPD: Weak Pull Down Resistor (internal)
- WPU: Weak Pull Up Resistor (internal)
- Power: Power Supply Pins
- Analog: Analog pins

Table 5-2. Pin States-1

PIN NO	PIN NAME	RESET		COPPER MODE					
				MII		RGMII		SGMII	
		PIN STATE	PULL/HI-Z	PIN STATE	PULL/HI-Z	PIN STATE	PULL/HI-Z	PIN STATE	PULL/HI-Z
14	SON	O	Hi-Z	O	Hi-Z	O	Hi-Z	O	50Ω
15	SOP	O	Hi-Z	O	Hi-Z	O	Hi-Z	O	50Ω
16	SIP	I	Hi-Z	I	Hi-Z	I	Hi-Z	I	50Ω
17	SIN	I	Hi-Z	I	Hi-Z	I	Hi-Z	I	50Ω
21	JTAG_CLK/ TX_ER	I	PU	I	PU	I	PU	I	PU
22	JTAG_TDO / GPIO_1	I	PD	O	Hi-Z	O	Hi-Z	O	Hi-Z
23	JTAG_TMS	I	PU	I	PU	I	PU	I	PU
24	JTAG_TDI / SD	I	PU	I	PU	I	PU	I	PU
25	TX_D3	I	PD	I	PD	I	PD	I	PD
26	TX_D2	I	PD	I	PD	I	PD	I	PD
27	TX_D1	I	PD	I	PD	I	PD	I	PD
28	TX_D0	I	PD	I	PD	I	PD	I	PD
29	GTX_CLK / TX_CLK	I	PD	O	PD	I	PD	I	PD
32	RX_CLK	I	PD	O	Hi-Z	O (125MHz)	Hi-Z	I	PD
33	RX_D0	I	PD	O	Hi-Z	O	Hi-Z	I	PD
34	RX_D1	I	PD	O	Hi-Z	O	Hi-Z	I	PD
35	RX_D2	I	PD	O	Hi-Z	O	Hi-Z	I	PD
36	RX_D3	I	PD	O	Hi-Z	O	Hi-Z	I	PD
37	TX_CTRL / TX_EN	I	PD	I	PD	I	PD	I	PD
38	RX_CTRL / RX_DV	I	PD	O	Hi-Z	O	Hi-Z	I	Hi-Z
40	CLK_OUT	O (25MHz)	Hi-Z	O (25MHz)	Hi-Z	O (25MHz)	Hi-Z	O (25MHz)	Hi-Z
41	MDIO	I	Hi-Z	I/O	Hi-Z	I/O	Hi-Z	I/O	Hi-Z
42	MDC	I	Hi-Z	I	Hi-Z	I	Hi-Z	I	Hi-Z
43	RESET_N	I	PU	I	PU	I	PU	I	PU
44	INT_N / PWDN_N	I	PU	I/O	PU/OD-PU	I/O	PU/OD-PU	I/O	PU/OD-PU
45	LED_2 / GPIO_0	I	PD	I/O	Hi-Z	I/O	Hi-Z	I/O	Hi-Z
46	LED_1 / RX_ER	I	PD	O	Hi-Z	O	Hi-Z	O	Hi-Z
47	LED_0	I	PD	O	Hi-Z	O	Hi-Z	O	Hi-Z

Table 5-3. Pin States-2

PIN NO	PIN NAME	MEDIA CONVERTOR		BRIDGE MODE			
				RGMII TO SGMII		SGMII TO RGMII	
		PIN STATE	PULL/HI-Z	PIN STATE	PULL/HI-Z	PIN STATE	PULL/HI-Z
14	SON	O	50Ω	O	50Ω	O	50Ω
15	SOP	O	50Ω	O	50Ω	O	50Ω
16	SIP	I	50Ω	I	50Ω	I	50Ω
17	SIN	I	50Ω	I	50Ω	I	50Ω
21	JTAG_CLK/ TX_ER	I	PU	I	PU	I	PU
22	JTAG_TDO / GPIO_1	O	Hi-Z	O	Hi-Z	O	Hi-Z
23	JTAG_TMS	I	PU	I	PU	I	PU
24	JTAG_TDI / SD	I	PU	I	PU	I	PU
25	TX_D3	I	PD	I	PD	I	PD
26	TX_D2	I	PD	I	PD	I	PD
27	TX_D1	I	PD	I	PD	I	PD
28	TX_D0	I	PD	I	PD	I	PD
29	GTX_CLK / TX_CLK	I	PD	I	PD	I	PD
32	RX_CLK	I	PD	O	Hi-Z	O	Hi-Z
33	RX_D0	I	PD	O	Hi-Z	O	Hi-Z
34	RX_D1	I	PD	O	Hi-Z	O	Hi-Z
36	RX_D2	I	PD	O	Hi-Z	O	Hi-Z
36	RX_D3	I	PD	O	Hi-Z	O	Hi-Z
37	TX_CTRL / TX_EN	I	PD	I	PD	I	PD
38	RX_CTRL / RX_DV	I	PD	O	Hi-Z	O	Hi-Z
40	CLK_OUT	O (25MHz)	Hi-Z	O (25MHz)	Hi-Z	O (25MHz)	Hi-Z
41	MDIO	I/O	Hi-Z	I/O	Hi-Z	I/O	Hi-Z
42	MDC	I	Hi-Z	I	Hi-Z	I	Hi-Z
43	RESET_N	I	PU	I	PU	I	PU
44	INT_N / PWDN_N	I/O	PU/OD-PU	I/O	PU/OD-PU	I/O	PU/OD-PU
45	LED_2 / GPIO_0	I/O	Hi-Z	I/O	Hi-Z	I/O	Hi-Z
46	LED_1 / RX_ER	O	Hi-Z	O	Hi-Z	O	Hi-Z
47	LED_0	O	Hi-Z	O	Hi-Z	O	Hi-Z

Table 5-4. Pin States-3

PIN NO	PIN NAME	IEEE PWDN		MII ISOLATE	
		PIN STATE	PULL/HI-Z	PIN STATE	PULL/HI-Z
14	SON	O	50Ω	O	50Ω
15	SOP	O	50Ω	O	50Ω
16	SIP	I	50Ω	I	50Ω
17	SIN	I	50Ω	I	50Ω
21	JTAG_CLK/ TX_ER	I/O	PU	I	PU
22	JTAG_TDO / GPIO_1	O	Hi-Z	O	Hi-Z
23	JTAG_TMS	I	PU	I	PU
24	JTAG_TDI / SD	I	PU	I	PU
25	TX_D3	I	PD	I	PD
26	TX_D2	I	PD	I	PD
27	TX_D1	I	PD	I	PD
28	TX_D0	I	PD	I	PD
29	GTX_CLK / TX_CLK	I	PD	I	PD
32	RX_CLK	O (2.5MHz)	Hi-Z	I	PD
33	RX_D0	O	Hi-Z	I	PD
34	RX_D1	O	Hi-Z	I	PD
36	RX_D2	O	Hi-Z	I	PD
36	RX_D3	O	Hi-Z	I	PD
37	TX_CTRL / TX_EN	I	PD	I	PD
38	RX_CTRL / RX_DV	O	Hi-Z	I	PD
40	CLK_OUT	O (25MHz)	Hi-Z	O (25MHz)	Hi-Z
41	MDIO	I	Hi-Z	I	Hi-Z
42	MDC	I	Hi-Z	I	Hi-Z
43	RESET_N	I	PU	I	PU
44	INT_N / PWDN_N	I/O	PU/OD-PU	I/O	PU/OD-PU
45	LED_2 / GPIO_0	O	Hi-Z	O	Hi-Z
46	LED_1 / RX_ER	O	Hi-Z	O	Hi-Z
47	LED_0	O	Hi-Z	O	Hi-Z

6 Specifications

6.1 Absolute Maximum Ratings

over operating free-air temperature range (unless otherwise noted)⁽¹⁾

PARAMETER		MIN	MAX	UNIT
Supply voltage	VDD1P1	-0.3	1.4	V
	VDD1P8	-0.3	2.16	V
	VDD2P5	-0.3	3	V
	VDDIO (3V3)	-0.3	3.8	V
	VDDIO (2V5)	-0.3	3	V
	VDDIO (1V8)	-0.3	2.1	V
Pins	MDI	-0.3	6.5	V
Pins	MAC Interface, MDIO, MDC, GPIO	-0.3	VDDIO + 0.3	V
Pins	INT/PWDN, RESET	-0.3	VDDIO + 0.3	V
Pins	JTAG	-0.3	VDDIO + 0.3	V
Storage temperature	Tstg	-60	150	C

- (1) Stresses beyond those listed under *Absolute Maximum Rating* may cause permanent damage to the device. These are stress ratings only, which do not imply functional operation of the device at these or any other conditions beyond those indicated under *Recommended Operating Condition*. Exposure to absolute-maximum-rated conditions for extended periods may affect device reliability.

6.2 ESD Ratings

Parameter			VALUE	UNIT	
V _(ESD)	V(ESD) Electrostatic discharge	Human-body model (HBM), per ANSI/ESDA/JEDEC JS-001 ⁽¹⁾	All pins except MDI	+/-2500	V
			MDI pins ⁽²⁾	+/-8000	
		Charged-device model (CDM), per JEDEC specification JESD22-C101 ⁽³⁾	All Pins	+/-1500	
		IEC 61000-4-2 contact discharge	MDI pins	+/-8000	V

- (1) JEDEC document JEP155 states that 500V HBM allows safe manufacturing with a standard ESD control process. Manufacturing with less than 500V HBM is possible with the necessary precautions. Pins listed as $\pm 8\text{kV}$ and/or $\pm 2\text{kV}$ may actually have higher performance.
- (2) MDI Pins tested as per IEC 61000-4-2 standards.
- (3) JEDEC document JEP157 states that 250V CDM allows safe manufacturing with a standard ESD control process. Manufacturing with less than 250V CDM is possible with the necessary precautions. Pins listed as $\pm 500\text{V}$ may actually have higher performance.

6.3 Recommended Operating Conditions

over operating free-air temperature range (unless otherwise noted)

Parameter		MIN	NOM	MAX	UNIT
VDDIO	Digital Supply Voltage, 1.8V operation	1.71	1.8	1.89	V
	Digital Supply Voltage, 2.5V operation	2.375	2.5	2.625	
	Digital Supply Voltage, 3.3V operation	3.15	3.3	3.45	
VDD1P1	Digital Supply	0.99	1.1	1.21	V
VDDA1P8	Analog Supply	1.71	1.8	1.89	V
VDDA2P5	Analog Supply	2.375	2.5	2.625	V
T _A	Operating Ambient Temperature	-40		125	°C
T _j	Operating Junction Temperature	-40		140	°C

6.4 Thermal Information

THERMAL METRIC ⁽¹⁾		48PIN VQFN	UNIT
R _{θJA}	Junction-to-ambient thermal resistance	30.8	°C/W
R _{θJC(top)}	Junction-to-case (top) thermal resistance	18.7	°C/W
R _{θJC(bot)}	Junction-to-case (bottom) thermal resistance	1.4	°C/W
R _{θJB}	Junction-to-board thermal resistance	7.5	°C/W
Ψ _{JT}	Junction-to-top characterization parameter	0.3	°C/W
Ψ _{JB}	Junction-to-board characterization parameter	7.5	°C/W

(1) For more information about traditional and new thermal metrics, see the [Semiconductor and IC Package Thermal Metrics](#) application report.

6.5 Electrical Characteristics

over operating free-air temperature range (unless otherwise noted)

PARAMETER	TEST CONDITIONS	MIN	TYP	MAX	UNIT
1000Base-X/100Base-FX/SGMII INPUT					
Input differential voltage tolerance	SI_P and SI_N, AC coupled	0.3	0.5	2.0	V
Receiver differential input impedance (DC)		80	100	120	Ohm
Frequency tolerance	SI_P and SI_N, AC coupled	-100		+100	ppm
1000Base-X OUTPUT					
Clock signal duty cycle	SO_P and SO_N, AC coupled, 0101010101 pattern	48		52	%
Vod fall time (20%-80%)	SO_P and SO_N, AC coupled, 0101010101 pattern	100		200	ps
Vod rise time (20%-80%)	SO_P and SO_N, AC coupled, 0101010101 pattern	100		200	ps
Total Ouput Jitter	SO_P and SO_N, AC coupled		192		ps
Output Differential Voltage	SO_P and SO_N, AC coupled	1060	1100	1140	mV
100Base-FX OUTPUT					
Clock signal duty cycle at 625MHz	SO_P and SO_N, AC coupled			55	%
Vod fall time (20%-80%)	SO_P and SO_N, AC coupled			330	ps
Vod rise time (20%-80%)	SO_P and SO_N, AC coupled			330	ps
Jitter	SO_P and SO_N, AC coupled			192	ps
Output Differential Voltage	SO_P and SO_N, AC coupled	450		910	mV
SGMII OUTPUT					
Clock signal duty cycle @625MHz	SO_P and SO_N, AC coupled, 0101010101 pattern	48		52	%
Vod fall time (20%-80%)	SO_P and SO_N, AC coupled, 0101010101 pattern	100		200	ps
Vod rise time (20%-80%)	SO_P and SO_N, AC coupled, 0101010101 pattern	100		200	ps
Output Jitter	SO_P and SO_N, AC coupled			300	ps
Output Differential Voltage	SO_P and SO_N, AC coupled	1060	1100	1140	mV
IEEE Tx CONFORMANCE (1000BaseT)					
Output Differential Voltage	Normal Mode, All channels	0.67	0.745	0.82	V
IEEE Tx CONFORMANCE (100BaseTx)					
Output Differential Voltage	Normal Mode, Channels A and B	0.95	1.00	1.05	V
IEEE Tx CONFORMANCE (10BaseTe)					
Output Differential Voltage			1.75		V

6.5 Electrical Characteristics (continued)

over operating free-air temperature range (unless otherwise noted)

PARAMETER		TEST CONDITIONS	MIN	TYP	MAX	UNIT
POWER CONSUMPTION Copper mode (100m cable)						
Total	RGMII to Copper (1G)	Room Temperature, Nominal supply voltages		483		mW
	RGMII to Copper (100M)			215		mW
	RGMII to Copper (10M)			260		mW
	MII to Copper (100M)			212		mW
	MII to Copper (10M)			261		mW
	SGMII to Copper (1G)			496		mW
	SGMII to Copper (100M)			251		mW
	SGMII to Copper (10M)			294		mW
I(1V1)	RGMII to Copper (1G)	Room Temperature, 1.1V supply voltage		131	195	mA
	RGMII to Copper (100M)			47	110	mA
	RGMII to Copper (10M)			37	100	mA
	MII to Copper (100M)			43	110	mA
	MII to Copper (10M)			36	95	mA
	SGMII to Copper (1G)			141	220	mA
	SGMII to Copper (100M)			60	125	mA
	SGMII to Copper (10M)			50	112	mA
I(1V8)	RGMII to Copper (1G)	Room Temperature, 1.8V supply voltage		52	55	mA
	RGMII to Copper (100M)			21	26	mA
	RGMII to Copper (10M)			11	15	mA
	MII to Copper (100M)			21	26	mA
	MII to Copper (10M)			10	15	mA
	SGMII to Copper (1G)			55	60	mA
	SGMII to Copper (100M)			24	28	mA
	SGMII to Copper (10M)			14	18	mA
I(2V5)	RGMII to Copper (1G)	Room Temperature, 2.5V supply voltage		86	100	mA
	RGMII to Copper (100M)			46	50	mA
	RGMII to Copper (10M)			76	90	mA
	MII to Copper (100M)			45	52	mA
	MII to Copper (10M)			78	92	mA
	SGMII to Copper (1G)			93	100	mA
	SGMII to Copper (100M)			53	58	mA
	SGMII to Copper (10M)			82	95	mA
I(VDDIO =3.3V)	RGMII to Copper (1G)	Room Temperature, 3.3V supply voltage		30	80	mA
	RGMII to Copper (100M)			13	22	mA
	RGMII to Copper (10M)			10	16	mA
	MII to Copper (100M)			15	66	mA
	MII to Copper (10M)			11	38	mA
	SGMII to Copper (1G)			10	16	mA
	SGMII to Copper (100M)			10	16	mA
	SGMII to Copper (10M)			10	16	mA

6.5 Electrical Characteristics (continued)

over operating free-air temperature range (unless otherwise noted)

PARAMETER		TEST CONDITIONS	MIN	TYP	MAX	UNIT
I(VDDIO = 1.8V)	RGMII to Copper (1G)	Room Temperature, 1.8V supply voltage		17	30	mA
	RGMII to Copper (100M)			6	12	mA
	RGMII to Copper (10M)			5	10	mA
	MII to Copper (100M)			8	15	mA
	MII to Copper (10M)			5	10	mA
	SGMII to Copper (1G)			5	10	mA
	SGMII to Copper (100M)			5	10	mA
	SGMII to Copper (10M)			5	10	mA
POWER CONSUMPTION Fiber mode						
Total	RGMII to 1000Base-X	Room Temperature, Nominal supply voltages		142		mW
	RGMII to 100Base-FX			111		mW
	MII to 100Base-FX			107		mW
I(1V1)	RGMII to 1000Base-X	Room Temperature, 1.1V supply voltage		52		mA
	RGMII to 100Base-FX			44		mA
	MII to 100Base-FX			41.8		mA
I(1V8)	RGMII to 1000Base-X	Room Temperature, 1.8V supply voltage		14		mA
	RGMII to 100Base-FX			14		mA
	MII to 100Base-FX			12		mA
I(2V5)	RGMII to 1000Base-X	Room Temperature, 2.5V supply voltage		11		mA
	RGMII to 100Base-FX			10		mA
	MII to 100Base-FX			10		mA
I(VDDIO = 3.3V)	RGMII to 1000Base-X	Room Temperature, 3.3V supply voltage		32		mA
	RGMII to 100Base-FX			14		mA
	MII to 100Base-FX			16		mA
I(VDDIO = 1.8V)	RGMII to 1000Base-X	Room Temperature, 1.8V supply voltage		18		mA
	RGMII to 100Base-FX			7		mA
	MII to 100Base-FX			8		mA
POWER CONSUMPTION R2S mode						
Total	RGMII to SGMII (1G)	Room Temperature, Nominal supply voltages		142		mW
	RGMII to SGMII (100M)			120		mW
	RGMII to SGMII (10M)			117		mW
I(1V1)	RGMII to SGMII (1G)	Room Temperature, 1.1V supply voltage		52		mA
	RGMII to SGMII (100M)			50		mA
	RGMII to SGMII (10M)			49		mA
I(1V8)	RGMII to SGMII (1G)	Room Temperature, 1.8V supply voltage		14		mA
	RGMII to SGMII (100M)			13		mA
	RGMII to SGMII (10M)			14		mA
I(2V5)	RGMII to SGMII (1G)	Room Temperature, 2.5V supply voltage		11		mA
	RGMII to SGMII (100M)			11		mA
	RGMII to SGMII (10M)			11		mA
I(VDDIO = 3.3V)	RGMII to SGMII (1G)	Room Temperature, 3.3V supply voltage		32		mA
	RGMII to SGMII (100M)			15		mA
	RGMII to SGMII (10M)			12		mA

6.5 Electrical Characteristics (continued)

over operating free-air temperature range (unless otherwise noted)

PARAMETER		TEST CONDITIONS	MIN	TYP	MAX	UNIT
I(VDDIO =1.8V)	RGMII to SGMII (1G)	Room Temperature, 1.8V supply voltage		18		mA
	RGMII to SGMII (100M)			8		mA
	RGMII to SGMII (10M)			6		mA
POWER CONSUMPTION S2R mode						
Total	SGMII to RGMII (1G)	Room Temperature, Nominal supply voltages		142		mW
	SGMII to RGMII (100M)			121		mW
	SGMII to RGMII (10M)			117		mW
I(1V1)	SGMII to RGMII (1G)	Room Temperature, 1.1V supply voltage		52		mA
	SGMII to RGMII (100M)			49		mA
	SGMII to RGMII (10M)			49		mA
I(1V8)	SGMII to RGMII (1G)	Room Temperature, 1.8V supply voltage		14		mA
	SGMII to RGMII (100M)			14		mA
	SGMII to RGMII (10M)			14		mA
I(2V5)	SGMII to RGMII (1G)	Room Temperature, 2.5V supply voltage		11		mA
	SGMII to RGMII (100M)			11		mA
	SGMII to RGMII (10M)			11		mA
I(VDDIO =3.3V)	SGMII to RGMII (1G)	Room Temperature, 3.3V supply voltage		33		mA
	SGMII to RGMII (100M)			16		mA
	SGMII to RGMII (10M)			13		mA
I(VDDIO =1.8V)	SGMII to RGMII (1G)	Room Temperature, 1.8V supply voltage		18		mA
	SGMII to RGMII (100M)			8		mA
	SGMII to RGMII (10M)			6		mA
POWER CONSUMPTION Cu-Fiber mode (100m cable)						
Total	1000Base-TX to 1000Base-FX	Room Temperature, Nominal supply voltage		495		mW
	100Base-TX to 100Base-FX			243		mW
I(1V1)	1000Base-TX to 1000Base-FX	Room Temperature, 1.1V supply voltage		142		mA
	100Base-TX to 100Base-FX			55		mA
I(1V8)	1000Base-TX to 1000Base-FX	Room Temperature, 1.8V supply voltage		55		mA
	100Base-TX to 100Base-FX			24		mA
I(2V5)	1000Base-TX to 1000Base-FX	Room Temperature, 2.5V supply voltage		93		mA
	100Base-TX to 100Base-FX			52		mA
I(VDDIO =3.3V)	1000Base-TX to 1000Base-FX	Room Temperature, 3.3V supply voltage		9		mA
	100Base-TX to 100Base-FX			10		mA
I(VDDIO =1.8V)	1000Base-TX to 1000Base-FX	Room Temperature, 1.8V supply voltage		4		mA
	100Base-TX to 100Base-FX			5		mA
POWER CONSUMPTION Low power modes						
Total	IEEE Power Down	Room Temperature, Nominal Voltages		76		mW
	Active Sleep			165		mW
	RESET			82		mW
BOOTSTRAP DC CHARACTERISTICS (4 Level) (PHY address pins)						
V _{MODE0}	Mode 0 Strap Voltage Range		0	0.093 x VDDIO		V
V _{MODE1}	Mode 1 Strap Voltage Range		0.136 x VDDIO	0.184 x VDDIO		V

6.5 Electrical Characteristics (continued)

over operating free-air temperature range (unless otherwise noted)

PARAMETER		TEST CONDITIONS	MIN	TYP	MAX	UNIT
V _{MODE2}	Mode 2 Strap Voltage Range		0.219 x VDDIO		0.280 x VDDIO	V
V _{MODE3}	Mode 3 Strap Voltage Range		0.6 x VDDIO		0.888 x VDDIO	V
BOOTSTRAP DC CHARACTERISTICS (2 Level)						
V _{MODE0}	Mode 0 Strap Voltage Range		0		0.18 x VDDIO	V
V _{MODE1}	Mode 1 Strap Voltage Range		0.5 x VDDIO		0.88 x VDDIO	V

6.5 Electrical Characteristics (continued)

over operating free-air temperature range (unless otherwise noted)

PARAMETER		TEST CONDITIONS	MIN	TYP	MAX	UNIT
IO CHARACTERISTICS						
V _{IH}	High Level Input Voltage	VDDIO = 3.3V ±5%	2			V
V _{IL}	Low Level Input Voltage	VDDIO = 3.3V ±5%			0.8	V
V _{OH}	High Level Output Voltage	I _{OH} = -2mA, VDDIO = 3.3V ±5%	2.4			V
V _{OL}	Low Level Output Voltage	I _{OL} = 2mA, VDDIO = 3.3V ±5%			0.4	V
V _{IH}	High Level Input Voltage	VDDIO = 2.5V ±5%	1.7			V
V _{IL}	Low Level Input Voltage	VDDIO = 2.5V ±5%			0.7	V
V _{OH}	High Level Output Voltage	I _{OH} = -2mA, VDDIO = 2.5V ±5%	2			V
V _{OL}	Low Level Output Voltage	I _{OL} = 2mA, VDDIO = 2.5V ±5%			0.4	V
V _{IH}	High Level Input Voltage	VDDIO = 1.8V ±5%	0.65*VD DIO			V
V _{IL}	Low Level Input Voltage	VDDIO = 1.8V ±5%		0.35*VD DIO		V
V _{OH}	High Level Output Voltage	I _{OH} = -2mA, VDDIO = 1.8V ±5%	VDDIO-0 .45			V
V _{OL}	Low Level Output Voltage	I _{OL} = 2mA, VDDIO = 1.8V ±5%			0.45	V
I _{IH}	Input High Current	T _A = -40°C to 125°C, VIN=VDDIO	-20		20	μA
I _{IL}	Input Low Current	T _A = -40°C to 125°C, VIN=GND	-20		20	μA
I _{ozh}	Tri-state Output High Current	T _A = -40°C to 125°C, VOUT=VDDIO	-20		20	μA
I _{ozl}	Tri-state Output Low Current	T _A = -40°C to 125°C, VOUT=GND	-20		20	μA
R _{pullDn}	Internal Pull Down Resistor		6.75	9	11.25	kΩ
XI V _{IH}	High Level Input Voltage		1.2		VDDIO	V
XI V _{IL}	Low Level Input Voltage				0.6	V
C _{IN}	Input Capacitance XI			1		pF
C _{IN}	Input Capacitance INPUT PINS			5		pF
C _{OUT}	Output Capacitance XO			1		pF
C _{OUT}	Output Capacitance OUTPUT PINS			5		pF
R _{series}	Integrated MAC Series Termination Resistor	RX_D[3:0], RX_ER, RX_DV, RX_CLK		50		Ω

6.6 Timing Requirements

PARAMETER		MIN	NOM	MAX	UNIT
POWER-UP TIMING (2, 3 supply mode)					
T1	Last Supply power up To Reset Release: External or via R-C network	200			ms
T2	Powerup to SMI ready: Post power-up stabilization time prior to MDC preamble for register access		200		ms
T3	Powerup to Strap latchin: Hardware configuration pins transition to output drivers		200		ms
RESET TIMING					
T1	Reset to SMI ready: Post reset stabilization time prior to MDC preamble for register access	30			us
T3	RESET PULSE Width: Miminum Reset pulse width to be able to reset	720			ns
T4	Reset to FLP		1750		ms
T4	Reset to 100M signaling (strapped mode)		194		us
T4	Reset to 1G signaling (strapped mode)		194		us
T4	Reset to Fiber 100M signaling		248		us
T4	Reset to Fiber 1G ANEG signaling		235		us
T4	Reset to Fiber 1G Forced signaling		235		us
T4	Reset to MAC clock (Cu mode)		195		us
T4	Reset to MAC clock (Fi mode)		248		us
T4	Reset to MAC clock (S2R)		248		us
T4	Reset to MAC clock (R2S)		248		us
COPPER LINK TIMING					
T1	Loss of Idles to Link LED low in Fast link down mode (100M)		4.3	10	us
	Loss of Idles to Link LED low in Fast link down mode (1000M)		7	10	us
MII TIMING (100M)					
T1	TX_CLK High / Low Time	16	20	24	ns
T2	TX_D[3:0], TX_ER, TX_EN Setup to TX_CLK	10			ns
T3	TX_D[3:0], TX_ER, TX_EN Hold from TX_CLK	0			ns
T1	RX_CLK High / Low Time	16	20	24	ns
T2	RX_D[3:0], RX_ER, RX_DV Delay from RX_CLK rising	10		30	ns
RGMII OUTPUT TIMING (1G)					
T _{skewT}	Data to Clock Output Skew (Non-Delay Mode)	-600		600	ps
T _{skewT(Delay)}	Data to Clock Output Setup (Delay Mode)	1.4		2.6	ns
T _{setupT}	Data to Clock Output Setup (Delay Mode)	1.2			ns
T _{holdT}	Data to Clock Output Hold (Delay Mode)	1.2			ns
T _{cyc}	Clock Cycle Duration	7.2	8	8.8	ns
	Duty Cycle	45	50	55	%
	Rise / Fall Time (20% to 80%)			0.75	ns
RGMII INPUT TIMING (1G)					
T _{setupR}	TX data to clock input setup (Non-Delay Mode)	1			ns
T _{holdR}	TX clock to data input hold (Non-Delay Mode)	1			ns
	TX data to clock input setup (Delay Mode, 2ns delay)	-1			ns
	TX clock to data input hold (Delay Mode, 2ns delay)	3			ns
SMI TIMING					
T1	MDC to MDIO (Output) Delay Time	0		10	ns
T2	MDIO (Input) to MDC Setup Time	10			ns

6.6 Timing Requirements (continued)

PARAMETER		MIN	NOM	MAX	UNIT
T3	MDIO (Input) to MDC Hold Time	10			ns
T4	MDC Frequency		2.5	25	MHz

6.6 Timing Requirements (continued)

PARAMETER		MIN	NOM	MAX	UNIT
OUTPUT CLOCK TIMING (25MHz clockout)					
	Frequency (PPM)	-100		100	-
	Duty Cycle	40		60	%
	Rise Time			5000	ps
	Fall Time			5000	ps
	Frequency		25		MHz
	Jitter (Long Term)			375	ps
OUTPUT CLOCK TIMING (SyncE 125/5 MHz recovered clock)					
	Frequency (PPM)	-100		100	ppm
	Duty Cycle	40		60	%
	Rise time			2500	ps
	Fall Time			2500	ps
	Jitter (Long Term)			1000	ps
25MHz INPUT CLOCK tolerance					
	Frequency Tolerance	-100		+100	ppm
	Rise / Fall Time (10%-90%)			8	ns
	Jitter Tolerance (Accumulated : TIE over 100K cycles)		75		ps
	Duty Cycle	40		60	%
TRANSMIT LATENCY TIMING					
Copper	RGMI to Cu (100M): Rising edge TX_CLK with assertion TX_CTRL to SSD symbol on MDI		169		ns
Copper	RGMI to Cu (1G): Roundtrip Latency (Transmit + Receive)			384	ns
RECEIVE LATENCY TIMING					
Copper	Cu to RGMII (100M): SSD symbol on MDI to a) Rising edge of RX_DV with assertion of RX_CTRL b) Rising edge of RX_DV with assertion of RX_Dx		192		ns

6.7 Timing Diagrams

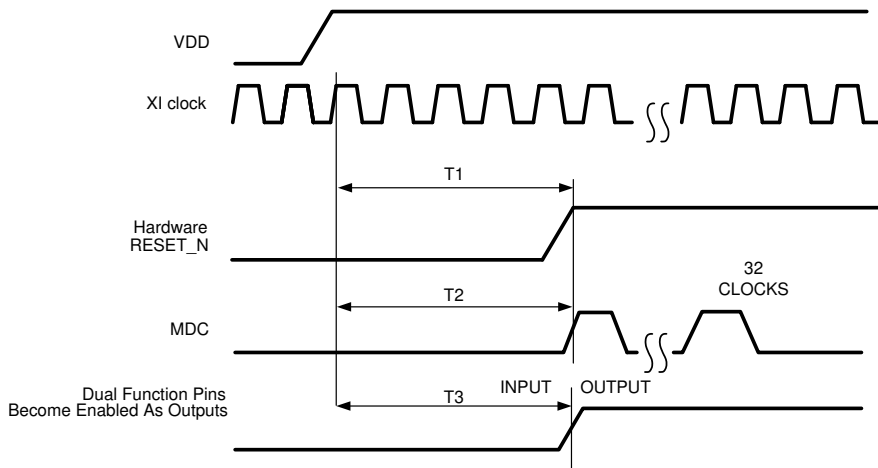

Figure 6-1. Power-Up Timing

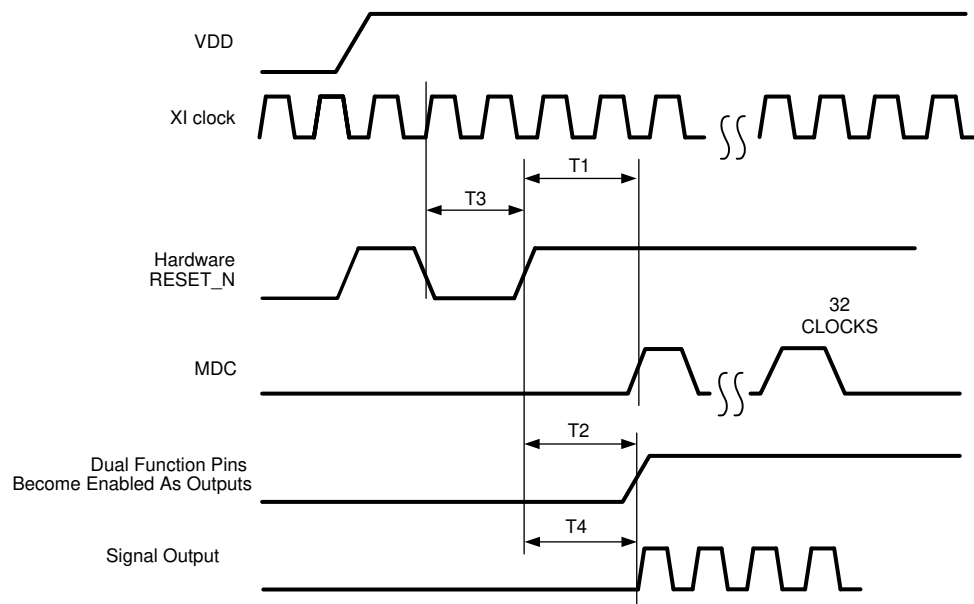

Figure 6-2. Reset Timing

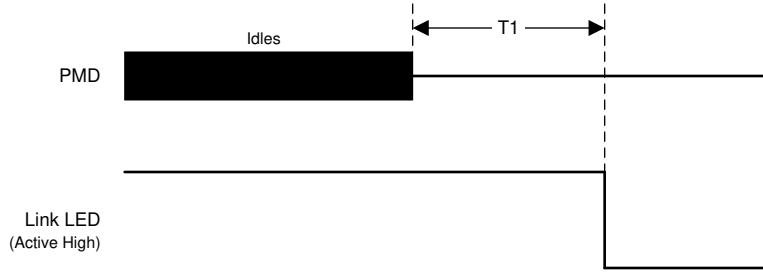

Figure 6-3. Copper Link Timing

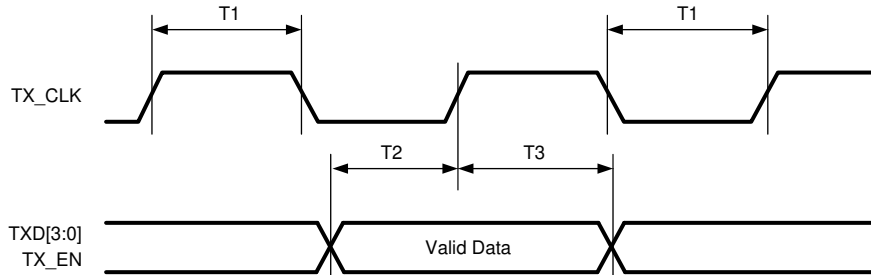

Figure 6-4. 100Mbps MII Transmit Timing

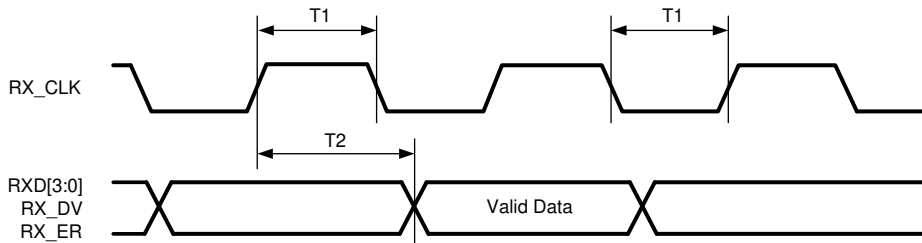

Figure 6-5. 100Mbps MII Receive Timing

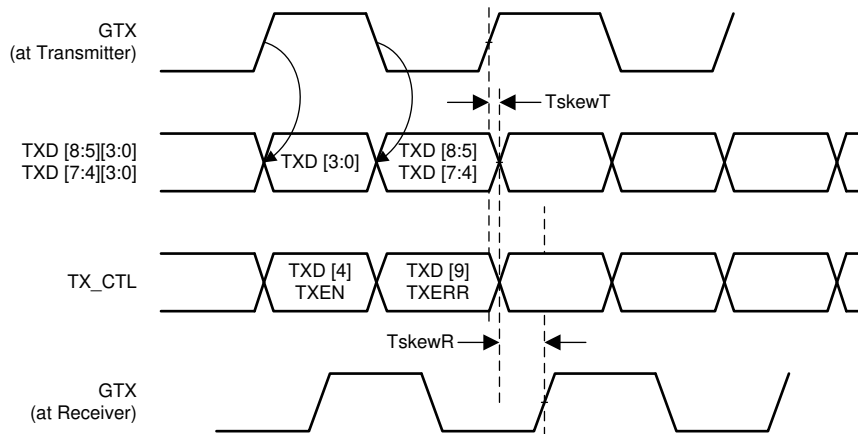

Figure 6-6. RGMII Transmit Multiplexing and Timing Diagram

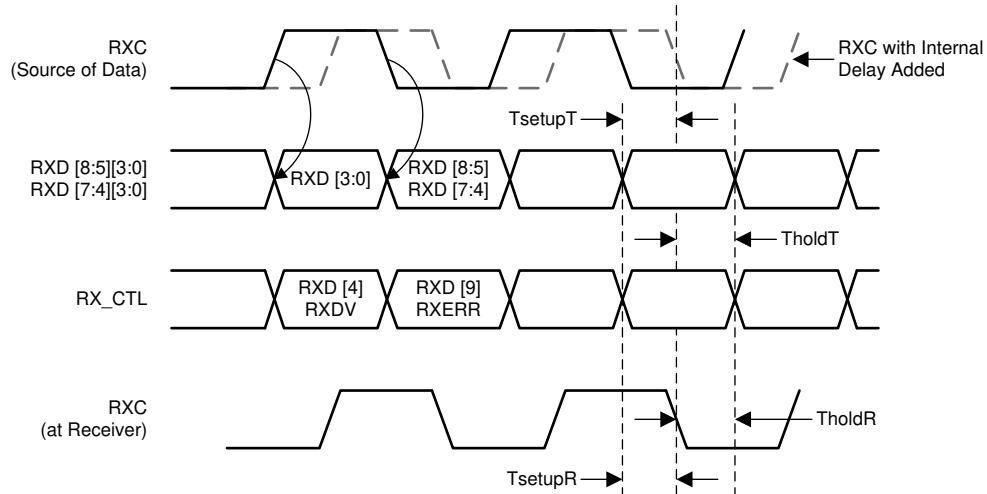

Figure 6-7. RGMII Receive Multiplexing and Timing Diagram

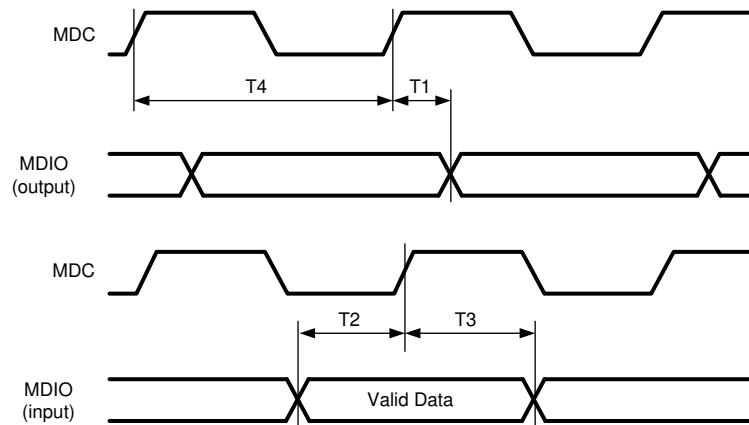
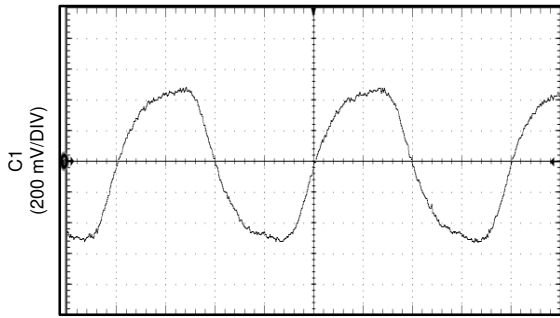

Figure 6-8. Serial Management Interface Timing

6.8 Typical Characteristics



mV/Div **ns/Div**
 200mV 4ns

Figure 6-9. 1000Base-T Test Mode 2 Signal

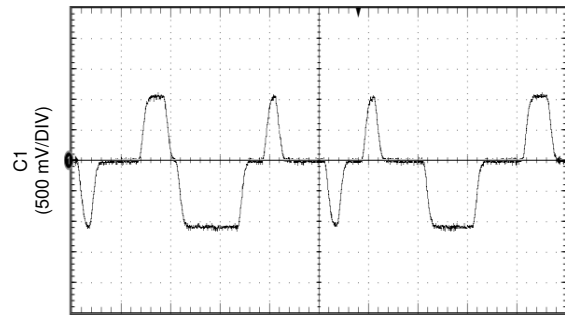

mV/Div **ns/Div**
 500mV 32ns

Figure 6-10. 100Base-TX Signal

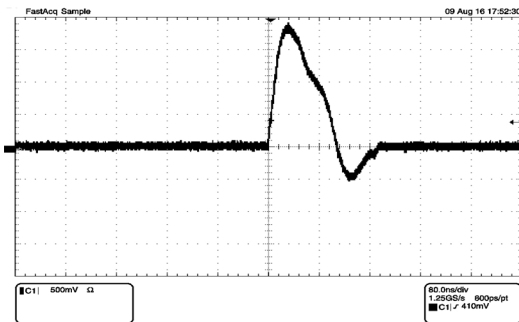

mV/Div **ns/Div**
 500mV 80ns

Figure 6-11. 10Base-Te Link Pulse

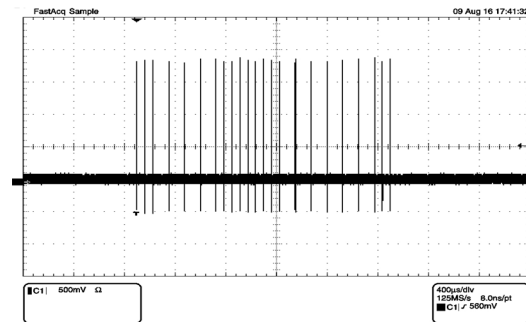

mV/Div **µs/Div**
 500mV 400µs

Figure 6-12. Auto-Negotiation FLP

7 Detailed Description

7.1 Overview

The DP83869HM is a fully-featured Gigabit Physical Layer transceiver with support for Fiber and Copper Ethernet standards. It can support IEEE802.3 10BASE-Te, 100BASE-TX, and 1000BASE-T Copper Ethernet protocols, along with 100BASE-FX and 1000BASE-X Fiber Ethernet protocols.

The DP83869HM is designed for easy implementation of 10Mbps, 100Mbps, and 1000Mbps Ethernet LANs. In Copper mode, the PHY can interface with twisted-pair media through magnetics. In Fiber Mode, it can interface with Fiber Optic Transceivers. This device interfaces directly to the MAC layer through the Reduced GMII (RGMII) or Serial GMII (SGMII). SGMII is available only in copper Ethernet mode. MII mode is supported for 10M and 100M speeds.

The DP83869HM supports media convertor mode to interface between copper and fiber Ethernet interface. Media convertor is available for 100M and 1000M speeds.

The DP83869HM can also support bridge mode to interface between SGMII and RGMII.

The DP83869HM offers low latency. It provides IEEE 1588 Start of Frame Delimiter indication. It has option to provide recovered clock for synchronous Ethernet application.

The DP83869HM has a TDR cable diagnostic feature for fault detection on the Ethernet cable.

7.2 Functional Block Diagram

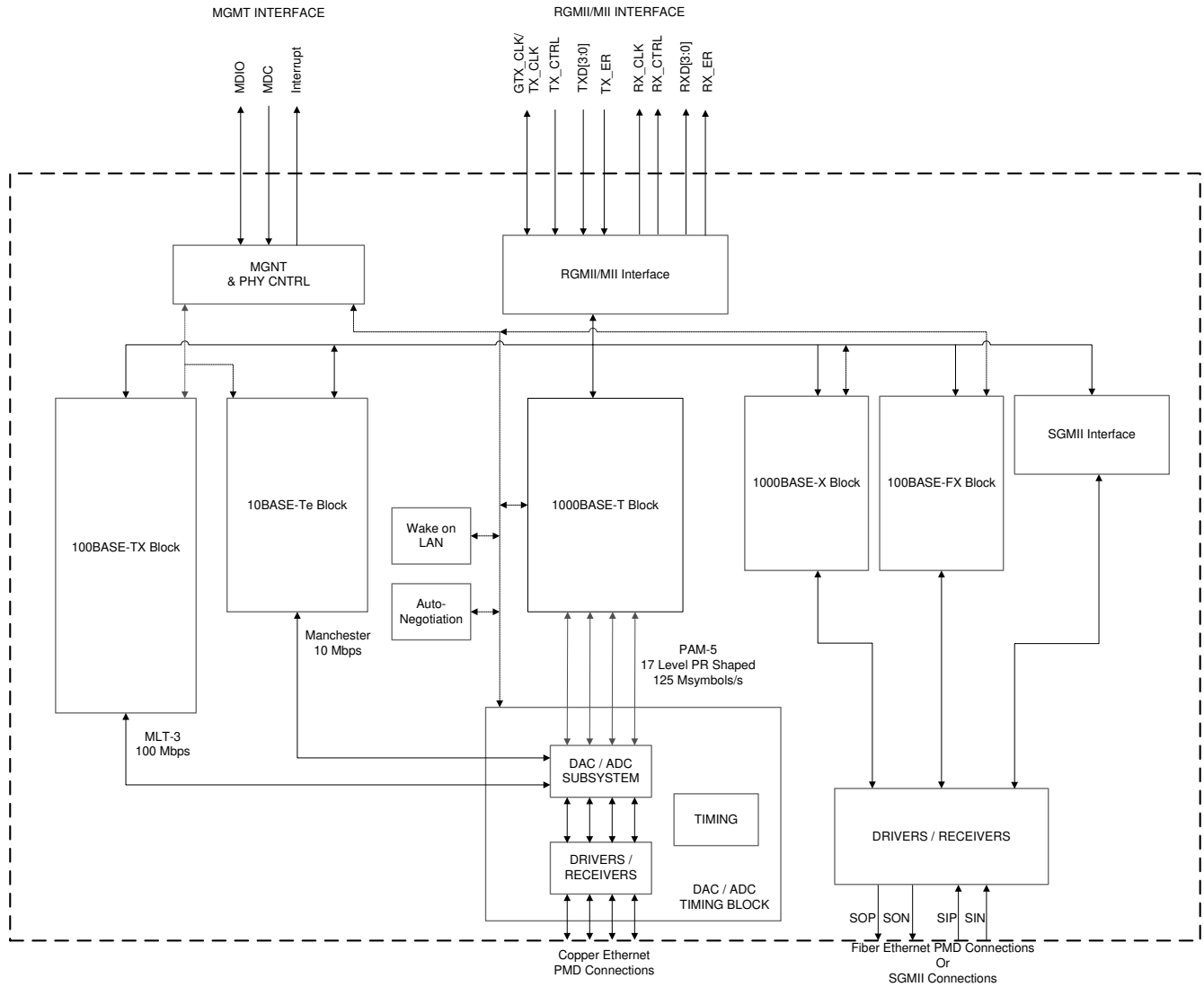

7.3 Feature Description

7.3.1 WoL (Wake-on-LAN) Packet Detection

Wake-on-LAN provides a mechanism to detect specific frames and notify the connected MAC through either a register status change, GPIO indication, or an interrupt flag. The WoL feature within the DP83869HM allows for connected devices placed above the Physical Layer to remain in a low power state until frames with the qualifying credentials are detected. Supported WoL frame types include: Magic Packet, Magic Packet with SecureOn, and Custom Pattern Match. When a qualifying WoL frame is received, the DP83869HM WoL logic circuit is able to generate a user-defined event (either pulses or level change) through any of the GPIO pins or a status interrupt flag to inform a connected controller that a wake event has occurred.

The Wake-on-LAN feature includes the following functionality:

- Identification of magic packets in all supported speeds
- Wake-up interrupt generation upon receiving a valid magic packet
- CRC checking of magic packets to prevent interrupt generation for invalid packets

In addition to the basic magic packet support, the DP83869HM also supports:

- Magic packets that include a SecureOn password
- Pattern match – one configurable 64-byte pattern of that can wake up the MAC similar to magic packet
- Independent configuration for Wake on Broadcast and Unicast packet types.

Note

[DP838xx Wake-on-LAN](#) app note provides further details and examples of Wake-on-LAN

7.3.1.1 Magic Packet Structure

When configured for Magic Packet mode, the DP83869HM scans all incoming frames addressed to the node for a specific data sequence. This sequence identifies the frame as a Magic Packet frame.

Note

The Magic Packet should be byte aligned.

A Magic Packet frame must also meet the basic requirements for the LAN technology chosen, such as SOURCE ADDRESS, DESTINATION ADDRESS (which may be the receiving station's IEEE address or a BROADCAST address), and CRC.

The specific Magic Packet sequence consists of 16 duplications of the IEEE address of this node, with no breaks or interruptions, followed by a SecureOn password if security is enabled. This sequence can be located anywhere within the packet, but must be preceded by a synchronization stream. The synchronization stream is defined as 6 bytes of FFh.

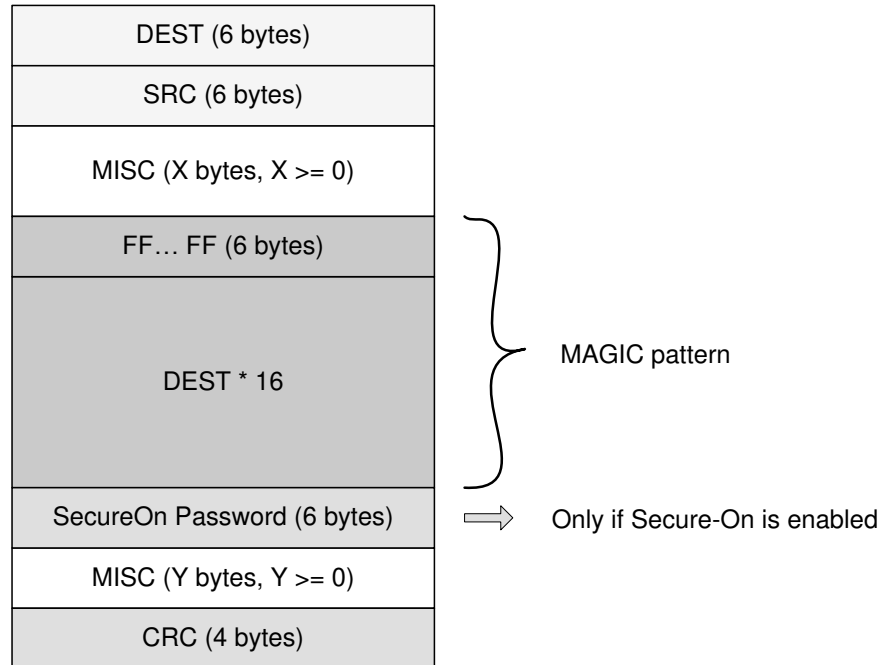

Figure 7-1. Magic Packet Structure

7.3.1.2 Wake-on-LAN Configuration and Status

Table 7-1. Magic Packet Detection Registers

REGISTER NAME	DP83869 ADDRESS
Receive Configuration Register	Reg 0x134
Receive Status Register	Reg 0x135
MAC Destination Address Registers	Reg 0x136-0x138
Receive Secure-ON Password Registers	Reg 0x139-0x13B
Byte Mask	Reg 0x15C-0x15F

7.3.2 Start of Frame Detect for IEEE 1588 Time Stamp

The DP83869HM supports an IEEE 1588 indication pulse at the SFD (start frame delimiter) for the receive and transmit paths. The pulse can be delivered to various pins. The pulse indicates the actual time the symbol is presented on the lines (for transmit), or the first symbol received (for receive). The exact timing of the pulse can be adjusted through register. Each increment of phase value is an 8-ns step.

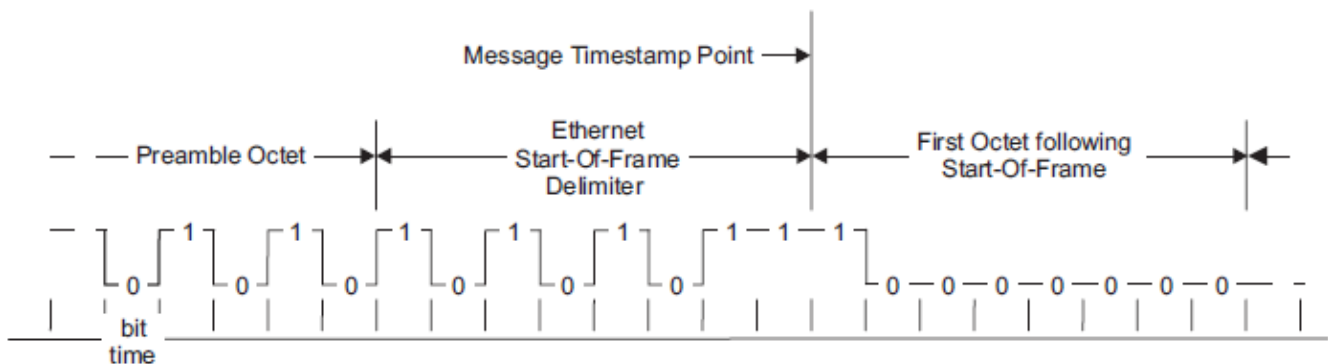

Figure 7-2. IEEE 1588 Message Timestamp Point

The SFD pulse output can be configured using the GPIO Mux Control register GPIO_MUX_CTRL (register address 1E0h). The ENHANCED_MAC_SUPPORT bit in RXCFG (register address 134h) must also be set to allow output of the SFD.

7.3.2.1 SFD Latency Variation and Determinism

Time stamping packet transmission and reception using the RX_CTRL and TX_CTRL signals of RGMII is not accurate enough for latency sensitive protocols. SFD pulses offers system designers a method to improve the accuracy of packet time stamping. The SFD pulse, while varying less than RGMII signals inherently, still exhibits latency variation due to the defined architecture of 1000BASE-T. This section provides a method to determine when an SFD latency variation has occurred and how to compensate for the variation in system software to improve timestamp accuracy.

In the following section the terms baseline latency and SFD variation are used. Baseline latency is the time measured between the TX_SFD pulse to the RX_SFD pulse of a connected link partner, assuming an Ethernet cable with all 4 pairs perfectly matched in propagation time. In the scenario where all 4 pairs being perfectly matched, a 1000BASE-T PHY will not have to align the 4 received symbols on the wire and will not introduce extra latency due to alignment.

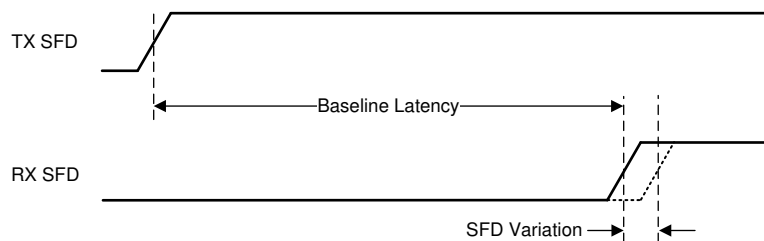

Figure 7-3. Baseline Latency and SFD Variation in Latency Measurement

SFD variation is additional time added to the baseline latency before the RX_SFD pulse when the PHY must introduce latency to align the 4 symbols from the Ethernet cable. Variation can occur when a new link is established either by cable connection, auto-negotiation restart, PHY reset, or other external system effects. During a single, uninterrupted link, the SFD variation will remain constant.

The DP83869HM can limit and report the variation applied to the SFD pulse while in the 1000Mb operating mode. Before a link is established in 1000Mb mode, the Sync FIFO Control Register (register address E9h) must be set to value 0xDF22. The below SFD variation compensation method can only be applied after the Sync FIFO Control Register has been initialized and a new link has been established. It is acceptable to set the Sync FIFO Control register value and then perform a software restart by setting the SW_RESTART bit[14] in the Control Register (register address 1Fh) if a link is already present.

7.3.2.1.1 1000Mb SFD Variation in Master Mode

When the DP83869HM is operating in 1000Mb master mode, variation of the RX_SFD pulse can be estimated using the Skew FIFO Status register (register address 55h) bit[7:4]. The value read from the Skew FIFO Status register bit[7:4] must be multiplied by 8ns to estimate the RX_SFD variation added to the baseline latency.

Example: While operating in master 1000Mb mode, a value of 0x2 is read from the Skew FIFO register bit[7:4]. $2 \times 8\text{ns} = 16\text{ns}$ is subtracted from the TX_SFD to RX_SFD measurement to determine the baseline latency.

7.3.2.1.2 1000Mb SFD Variation in Slave Mode

When the DP83869HM is operating in 1000Mb slave mode, the variation of the RX_SFD pulse can be determined using the Skew FIFO Status register (register address 55h) bit[3:0]. The value read from the Skew FIFO Status register bit[3:0] should be multiplied by 8ns to estimate the RX_SFD variation added to the baseline latency.

Example: While operating in slave 1000Mb mode, a value of 0x1 is read from the Skew FIFO register bit[3:0]. $1 \times 8\text{ns} = 8\text{ns}$ is subtracted from the TX_SFD to RX_SFD measurement to determine the baseline latency.

7.3.2.1.3 100-Mb SFD Variation

The latency variation in 100-Mb mode of operation is determined by random process and does not require any register readout or system level compensation of SFD pulses.

7.3.3 Clock Output

The DP83869HM has several internal clocks, including the local reference clock, the Ethernet transmit clock, and the Ethernet receive clock. An external crystal or oscillator provides the stimulus for the local reference clock. The local reference clock acts as the central source for all clocking in the device.

The local reference clock is embedded into the transmit network packet traffic and is recovered from the network packet traffic at the receiver node. The receive clock is recovered from the received Ethernet packet data stream and is locked to the transmit clock in the partner.

Using the I/O Configuration register (address 170h), the DP83869HM can be configured to output these internal clocks through the CLK_OUT pin. By default, the output clock is synchronous to the XI oscillator / crystal input. The default output clock is suitable for use as the reference clock of another DP83869HM device. Through registers, the output clock can be configured to be synchronous to the receive data at the 125MHz data rate or at the divide by 5 rate of 25MHz. It can also be configured to output the line driver transmit clock. When operating in 1000Base-T mode, the output clock can be configured for any of the four transmit or receive channels.

It is important to note that when clock output of DP83869HM is being used as a clock input for another device, for example two DP83869HM in daisy chain, then the primary DP83869HM must not be reset via the RESET pin. If reset is required then it should be performed via software. The output clock can be disabled using the CLK_O_DISABLE bit of the I/O Configuration register.

7.3.4 Loopback Mode

There are several options for Loopback that test and verify various functional blocks within the PHY. Enabling loopback mode allows in-circuit testing of the digital and analog data paths. Generally, the DP83869HM may be configured to one of the Near-end loopback modes or to the Far-end (reverse) loopback. MII Loopback is configured using the BMCR (register address 0h). All other loopback modes are enabled using the BIST_CONTROL (register address 16h). Except where otherwise noted, loopback modes are supported for all speeds (10/100/1000) and all MAC interfaces (SGMII and RGMII).

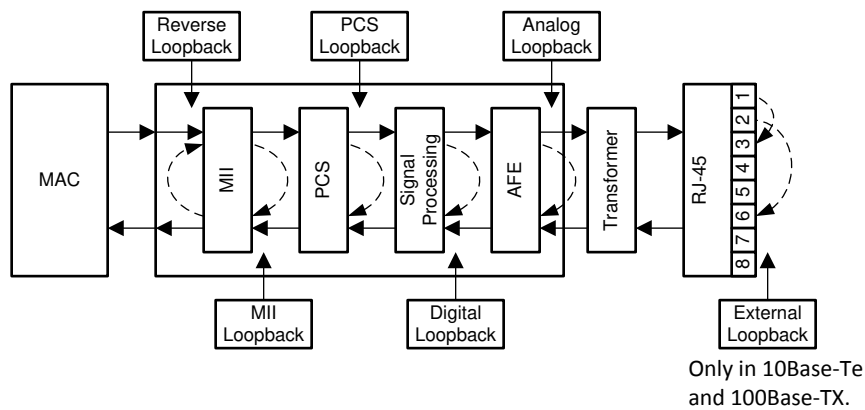

Figure 7-4. Loopbacks

7.3.4.1 Near-End Loopback

Near-end loopback provides the ability to loop the transmitted data back to the receiver through the digital or analog circuitry. The point at which the signal is looped back is selected using loopback control bits with several options being provided.

When configuring loopback modes, the Loopback Configuration Register (LOOPCR), address FEh, should be set to 0xE720.

To maintain the desired operating mode, Auto-Negotiation should be disabled before selecting the Near-End Loopback mode. This constraint does not apply for external-loopback mode.

Auto-MDIX should be disabled before selecting the Near-End Loopback mode. MDI or MDIX configuration should be manually configured.

7.3.4.1.1 MII Loopback

MII Loopback is the shallowest loop through the PHY. It is a useful test mode to validate communications between the MAC and the PHY. While in MII Loopback mode, the data is looped back and can be configured through the register to transmit onto the media. In 100Base-TX mode after MII loopback is enabled through register 0h, it is necessary to write 0x4 to register 16h for proper operation of MII Loopback.

7.3.4.1.2 PCS Loopback

PCS Loopback occurs in the PCS layer of the PHY. No signal processing is performed when using PCS Loopback.

7.3.4.1.3 Digital Loopback

Digital Loopback includes the entire digital transmit – receive path. Data is looped back prior to the analog circuitry.

7.3.4.1.4 Analog Loopback

Analog Loopback includes the entire analog transmit-receive path. For proper operation in Analog Loopback mode, attach 100Ω terminations to the copper side when operating in Copper mode and 100Ω termination on fiber side when operating in Fiber mode.

7.3.4.1.5 External Loopback

When operating in 10BASE-T or 100Base-T mode, signals can be looped back at the RJ-45 connector by wiring the transmit pins to the receive pins. Due to the nature of the signaling in 1000Base-T mode, this type of external loopback is not supported. Analog loopback provides a way to loop data back in the analog circuitry when operating in 1000Base-T mode.

7.3.4.1.6 Far-End (Reverse) Loopback

Far-end (Reverse) Loopback is a special test mode to allow testing the PHY from the link-partner side. In this mode, data that is received from the link partner passes through the PHY's receiver is looped back at the MAC interface and is transmitted back to the link partner. While in Reverse Loopback mode, all data signals that come from the MAC are ignored. Through register configuration, data can also be transmitted onto the MAC interface.

The availability of Loopback depends on the operational mode of the PHY. The Link Status in these loopback modes is also affected by the operational mode. [Table 7-2](#) lists out the exceptions where Loopbacks are not available.

Table 7-2. Loopback Availability Exception

OP MODE	LOOPBACK	EXCEPTION
Copper	PCS	10M
Fiber	MII	100M
	PCS	100M
	Analog	100M, 1000M
SGMII to RGMII	PCS	10M, 100M, 1000M
	Digital	10M, 100M, 1000M
	Analog	10M, 100M, 1000M
	External	10M, 100M, 1000M
RGMII to SGMII	PCS	10M, 100M, 1000M
	External	10M, 100M, 1000M

Table 7-2. Loopback Availability Exception (continued)

OP MODE	LOOPBACK	EXCEPTION
Media Convertor	MII	100M, 1000M
	Analog	100M on Fiber Interface
	External	100M on Fiber Interface
		100M, 1000M on Copper Interface

7.3.5 BIST Configuration

The device incorporates an internal PRBS Built-In Self Test (BIST) circuit to accommodate in-circuit testing or diagnostics. The BIST circuit can be used to test the integrity of the transmit and receive data paths. The BIST can be performed using both internal loopback (digital or analog) or external loopback using a cable fixture. The BIST simulates pseudo-random data transfer scenarios in format of real packets and Inter-Packet Gap (IPG) on the lines. The BIST allows full control of the packet lengths and of the IPG.

The BIST is implemented with independent transmit and receive paths, with the transmit block generating a continuous stream of a pseudo-random sequence. The device generates a 15-bit pseudo-random sequence for the BIST. The received data is compared to the generated pseudo-random data by the BIST Linear Feedback Shift Register (LFSR) to determine the BIST pass or fail status. The number of error bytes that the PRBS checker received is stored in the PRBS_TX_CHK_CTRL register (39h). The status of whether the PRBS checker is locked to the incoming receive bit stream, whether the PRBS has lost sync, and whether the packet generator is busy, can be read from the GEN_STATUS2 register (17h). While the lock and sync indications are required to identify the beginning of proper data reception, for any link failures or data corruption, the best indication is the contents of the error counter in the PRBS_TX_CHK_CTRL register (39h). The number of received bytes are stored in PRBS_TX_CHK_BYTE_CNT (3Ah).

The PRBS test can be put in a continuous mode by using the BIST_CONTROL register (16h). In continuous mode, when one of the PRBS counters reaches the maximum value, the counter starts counting from zero again. PRBS mode is not applicable in Bridge Modes and should not be used.

BIST Configuration Example:

1. Enable Digital Loopback
 - a. Write 0xE720 to register 0x00FE
 - b. Write 0x0140 to register 0x0000
 - c. Write 0x5028 to register 0x0010
 - d. Write 0x0004 to register 0x0016
2. Wait for link-up
 - a. PHY link status will go high, regardless if there is a cable connected or not.
3. Enable PRBS Transmit and checker towards copper
 - a. Write 0xF004 to register 0x00016
4. Wait for PRBS Lock
 - a. Wait for register 0x0017[11] to go high
5. Read the packet statistics
 - a. Write 0x0201 to register 0x0072 to latch the statistics
 - b. Read the registers below
 - i. 0x0071 (PRBS Byte Count)
 - ii. 0x0072 (bit[7:0] Error Count)
 - iii. 0x01A8 (Packet Count)
 - iv. 0x01A9 (Packet Count)

7.3.6 Interrupt

The DP83869HM can be configured to generate an interrupt when changes of internal status occur. The interrupt allows a MAC to act upon the status in the PHY without polling the PHY registers. The interrupt source can be selected through the interrupt registers, MICR (12h) and FIBER_INT_EN (C18h). The interrupt status can be read from ISR (13h) and FIBER_INT_STTS (C19h) registers. Some interrupts are enabled by default and can

be disabled through register access. Both the interrupt status registers must be read in order to clear pending interrupts. Until the pending interrupts are cleared, new interrupts may not be routed to the interrupt pin.

7.3.7 Power-Saving Modes

DP83869HM supports four power saving modes. The details are provided below.

7.3.7.1 IEEE Power Down

The PHY is powered down but access to the PHY through MDIO-MDC pins is retained. This mode can be activated by asserting external PWDN pin or by setting bit 11 of BMCR (Register 0h).

The PHY can be taken out of this mode by a power cycle, software reset, or by clearing the bit 11 in BMCR register. However, the external PWDN pin should be deasserted. If the PWDN pin is kept asserted then the PHY remains in power down.

7.3.7.2 Active Sleep

In this mode, all the digital and analog blocks are powered down. The PHY is automatically powered up when a link partner is detected. This mode is useful for saving power when the link partner is down or inactive, but PHY cannot be powered down. In Active Sleep mode, the PHY still routinely sends NLP to the link partner. This mode can be active by writing 10b to bits [9:8] for PHYCR (Register 10h). Sleep mode cannot be used when Auto-MDIX is on.

7.3.7.3 Passive Sleep

This is just like Active sleep except the PHY does not send NLP. This mode can be activated by writing 11b to bits [9:8] PHYCR (Register 10h). Sleep mode cannot be used when Auto-MDIX is on.

7.3.8 Mirror Mode

In some applications, the orientation of the cable connector can require Copper PMD traces to cross over each other. This complicates the board layout. The DP83869HM can resolve this issue by implementing mirroring of the ports inside the device.

In 10/100 operation, the mapping of the port mirroring is shown in [Table 7-3](#). When using mirror mode in 100Mbps mode, TI recommends that the user read register 0xA1 and write the same value in register A0h.

Table 7-3. Mirror Port Configurations in 10/100 Operation

MDI MODE	MIRROR PORT CONFIGURATION
MDI	A → D
	B → C
MDIX	A → D
	B → C

In Gigabit operation, the mapping of the port mirroring is shown in [Table 7-4](#).

Table 7-4. Mirror Port Configurations in Gigabit Operation

MDI MODE	MIRROR PORT CONFIGURATION
MDI or MDIX	A → D
	B → C
	C → B
	D → A

Mirror mode can be enabled through strap or through register configuration using the Port Mirror Enable bit in the CFG4 register (address 31h). In Mirror mode, the polarity of the signals is also reversed.

7.3.9 Speed Optimization

Speed optimization, also known as link downshift, enables fallback to 100M operation after multiple consecutive failed attempts at Gigabit link establishment. Such a case could occur if cabling with only four wires (two twisted pairs) were connected instead of the standard cabling with eight wires (four twisted pairs).

The number of failed link attempts before falling back to 100M operation is configurable. By default, four failed link attempts are required before falling back to 100M.

In enhanced mode, fallback to 100M can occur after one failed link attempt if energy is not detected on the C and D channels. Speed optimization also supports fallback to 10M if link establishment fails in Gigabit and in 100M mode.

Speed optimization can be enabled through register configuration.

7.3.10 Cable Diagnostics

With the vast deployment of Ethernet devices, the need for reliable, comprehensive and user-friendly cable diagnostic tool is more important than ever. The wide variety of cables, topologies, and connectors deployed results in the need to non-intrusively identify and report cable faults. The DP83869HM offers Time Domain Reflectometry (TDR) for Cable Diagnostics.

7.3.10.1 TDR

The DP83869HM uses Time Domain Reflectometry (TDR) to determine the quality of the cables, connectors, and terminations in addition to estimating the cable length. Some of the possible problems that can be diagnosed include opens, shorts, cable impedance mismatch, bad connectors, termination mismatches, cross faults, cross shorts, and any other discontinuities along the cable.

The DP83869HM transmits a test pulse of known amplitude down each of the two pairs of an attached cable. The transmitted signal continues down the cable and reflects from each cable imperfection, fault, bad connector, and from the end of the cable itself. After the pulse transmission, the DP83869HM measures the return time and amplitude of all these reflected pulses. This technique enables measuring the distance and magnitude (impedance) of non-terminated cables (open or short), discontinuities (bad connectors), improperly-terminated cables, and crossed pairs wires with $\pm 1\text{m}$ accuracy.

The DP83869HM also uses data averaging to reduce noise and improve accuracy. The DP83869HM can record up to five reflections within the tested pair. If more than 5 reflections are recorded, the DP83869HM saves the first 5 of them. If a cross fault is detected, the TDR saves the first location of the cross fault and up to 4 reflections in the tested channel. The DP83869HM TDR can measure cables beyond 100m in length.

For all TDR measurements, the transformation between time of arrival and physical distance is done by the external host using minor computations (such as multiplication, addition, and lookup tables). The host must know the expected propagation delay of the cable, which depends, among other things, on the cable category (for example, CAT5, CAT5e, or CAT6).

TDR measurement is allowed in the DP83869HM in the following scenarios:

- While Link partner is disconnected – cable is unplugged at the other side
- Link partner is connected but remains *quiet* (for example, in power-down mode)
- TDR can be automatically activated when the link fails or is dropped by setting bit 7 of register 9h (CFG1).
The results of the TDR run after the link fails are saved in the TDR registers.

Software could read these registers at any time to apply post processing on the TDR results. This mode is designed for cases when the link is dropped due to cable disconnections. After a link failure, for instance, the line is quiet to allow a proper function of the TDR.

7.3.11 Fast Link Drop

The DP83869HM includes advanced link-down capabilities that support various real-time applications. The link down mechanism is configurable and includes enhanced modes that allow extremely fast reaction times to link drops.

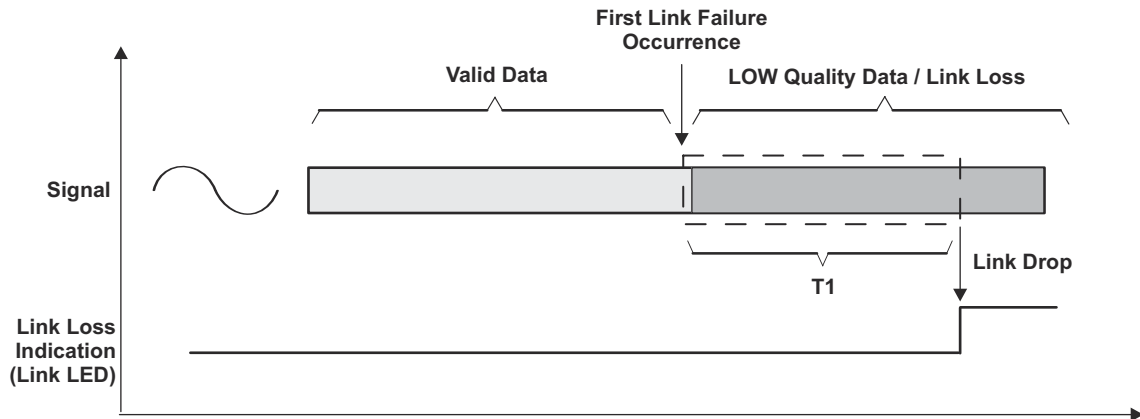

Figure 7-5. Fast Link Drop Mechanism

As described in [Figure 7-5](#), the link loss mechanism is based on a time window search period in which the signal behavior is monitored. The T1 window is set by default to reduce typical link drops to less than 1ms in 100M and 0.5ms in 1000M mode.

The DP83869HM supports enhanced modes that shorten the window called Fast Link Down mode. In this mode, the T1 window is shortened significantly, in most cases less than 10 μ s. In this period of time, there are several criteria allowed to generate link loss event and drop the link:

1. Loss of descrambler sync
2. Receive errors
3. MLT3 errors
4. Mean Squared Error (MSE)
5. Energy loss

The Fast Link Down functionality allows the use of each of these options separately or in any combination. Note that because this mode enables extremely quick reaction time, it is more exposed to temporary bad link quality scenarios.

7.3.12 Jumbo Frames

Conventional Ethernet frames have a maximum size of about 1518 bytes. Jumbo Frames are special packets with size higher than 1518 bytes, often ranging into several thousands of bytes. Jumbo frames allow Ethernet systems to transfer large chunks of data in a single frame reducing the processor overhead and increasing bandwidth efficiency. DP83869 supports Jumbo frames in 1000Mbps and 100Mbps speeds.

7.4 Device Functional Modes

7.4.1 Copper Ethernet

7.4.1.1 1000BASE-T

The DP83869HM supports the 1000BASE-T standard as defined by the IEEE 802.3 standard. In 1000M mode, the PHY will use four MDI channels for communication. The 1000BASE-T can work in Auto-Negotiation mode. The PHY can be configured in 1000BASE-T through the register settings ([Section 7.4.8](#)) or strap settings ([Section 7.5.1.2](#)).

7.4.1.2 100BASE-TX

The DP83869HM supports the 100BASE-TX standard as defined by the IEEE 802.3 standard. In 100M mode, the PHY will use two MDI channels for communication. The 100BASE-TX can work in Auto-Negotiation mode or in force mode. The PHY can be configured in 100BASE-TX through the register settings ([Section 7.4.8](#)) or strap settings ([Section 7.5.1.2](#)). When using DP83869 in force 100Base-TX mode, it is required to enable Robust Auto-MDIX feature from register 1Eh.

7.4.1.3 10BASE-Te

The DP83869HM supports the 10BASE-Te standard as defined by the IEEE 802.3 standard. In 100M mode, the PHY will use two MDI channels for communication. The 10BASE-Te can work in Auto-Negotiation mode or in force mode. The PHY can be configured in 10BASE-Te through the register settings ([Section 7.4.8](#)) or strap settings ([Section 7.5.1.2](#)).

7.4.2 Fiber Ethernet

7.4.2.1 1000BASE-X

The DP83869HM supports the 1000Base-X Fiber Ethernet protocol as defined in IEEE 802.3 standard. In 1000M Fiber mode, the PHY will use two differential channels for communication. In fiber mode, the speed is not decided through auto-negotiation. Both sides of the link must be configured to the same operating speed. The PHY can be configured to operate in 1000BASE-X through the register settings ([Section 7.4.8](#)) or strap settings ([Section 7.5.1.2](#)).

7.4.2.2 100BASE-FX

The DP83869HM supports the 100Base-FX Fiber Ethernet protocol as defined in IEEE 802.3 standard. In 100M Fiber mode, the PHY will use two differential channels for communication. In fiber mode, the speed is not decided through auto-negotiation. Both sides of the link must be configured to the same operating speed. The PHY can be configured to operate in 100BASE-X through register settings ([Section 7.4.8](#)) or strap settings ([Section 7.5.1.2](#)).

7.4.3 Serial GMII (SGMII)

The Serial Gigabit Media Independent Interface (SGMII) provides a means of conveying network data and port speed between a 100/1000 PHY and a MAC with significantly less signal pins (4 or 6 pins) than required for GMII (24 pins) or RGMII (12 pins). The SGMII interface uses 1.25Gbps LVDS differential signaling which has the added benefit of reducing EMI emissions relative to GMII or RGMII.

Because the internal clock and data recovery circuitry (CDR) of DP83869HM can detect the transmit timing of the SGMII data, TX_CLK is not required. The DP83869HM supports only 4-wire SGMII mode. Two differential pairs are used for the transmit and receive connections. Clock and data recovery are performed in the MAC and in the PHY, so no additional differential pair is required for clocking.

The 1.25Gbps rate of SGMII is excessive for 100Mbps and 10Mbps operation. When operating in 100Mbps mode, the PHY *elongates* the frame by replicating each frame byte 10 times and when in 10Mbps mode the PHY *elongates* the frame by replicating each frame byte 100 times. This frame elongation takes place *above* the IEEE 802.3 PCS layer, thus the start of frame delimiter only appears once per frame.

The SGMII interface includes Auto-Negotiation capability. Auto-Negotiation provides a mechanism for control information to be exchanged between the PHY and the MAC. This allows the interface to be automatically

configured based on the media speed mode resolution on the MDI side. In MAC loopback mode, the SGMII speed is determined by the MDI speed selection. The SGMII interface works in both Auto-Negotiation and forced speed mode during the MAC loopback operation. SGMII Auto-Negotiation is the default mode of the operation.

The SGMII Auto-Negotiation process can be disabled and the SGMII speed mode can be forced to the MDI resolved speed. The SGMII forced speed mode can be enabled with the MDI auto-negotiation or MDI manual speed mode. SGMII Auto-Negotiation can be disabled through the SGMII_AUTONEG_EN register bit in the CFG2 register (address 14h).

The 10M_SGMII_RATE_ADAPT bit (bit 7) of 10M_SGMII_CFG register (16Fh) needs to be cleared for enabling 10M SGMII operation.

SGMII is enabled through a resistor strap option. See [Section 7.5.1](#) for details.

All SGMII connections must be AC-coupled through an 0.1µF capacitor.

The connection diagrams for 4-wire SGMII is shown in [Figure 7-6](#).

Note

MII Isolate (bit 10 in register 0h) does not isolate SGMII pins. SGMII can be disabled through register 1DFh for isolating SGMII pins.

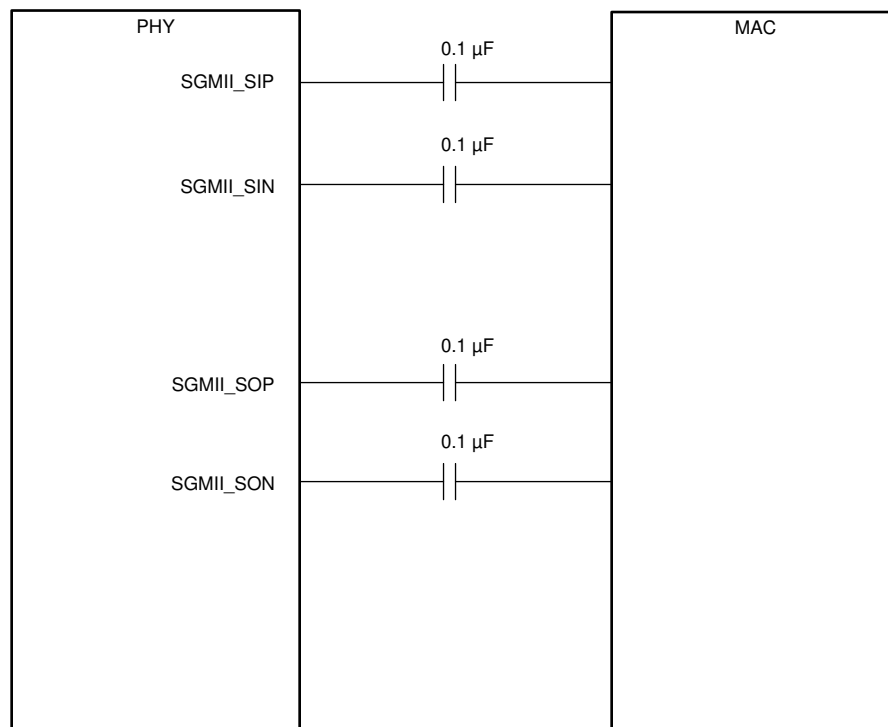

Figure 7-6. SGMII 4-Wire Connections

7.4.4 Reduced GMII (RGMII)

The Reduced Gigabit Media Independent Interface (RGMII) is designed to reduce the number of pins required to interconnect the MAC and PHY (12 pins for RGMII relative to 24 pins for GMII). To accomplish this goal, the data paths and all associated control signals are reduced and are multiplexed. Both rising and trailing edges of the clock are used. For Gigabit operation, the GTX_CLK and RX_CLK clocks are 125MHz, and for 10 and 100Mbps operation, the clock frequencies are 2.5MHz and 25MHz, respectively.

For more information about RGMII timing, see the [RGMII Interface Timing Budgets](#) application report (SNLA243).

7.4.4.1 1000Mbps Mode Operation

All RGMII signals are positive logic. The 8-bit data is multiplexed by taking advantage of both clock edges. The lower 4 bits are latched on the positive clock edge and the upper 4 bits are latched on trailing clock edge. The control signals are multiplexed into a single clock cycle using the same technique.

To reduce power consumption of RGMII interface, (TX_EN - TX_ER) and (RX_DV - RX_ER) are encoded in a manner that minimizes transitions during normal network operation. TX_CTRL pin will denote TX_EN on rising edge of GTX_CLK and will denote a logic derivative of TX_EN and TX_ER on the falling edge of GTX_CLK. RX_CTRL will denote RX_DV on rising edge of RX_CLK and will denote a logic derivative of RX_DV and RX_ER on the falling edge of RX_CLK. The encoding for the TX_ER and RX_ER is given in [Equation 1](#) and [Equation 2](#):

$$\text{TX_ER} = \text{GMII_TX_ER (XOR) GMII_TX_EN} \tag{1}$$

where

- GMII_TX_ER and GMII_TX_EN are logical equivalent signals in GMII standard.

$$\text{RX_ER} = \text{GMII_RX_ER (XOR) GMII_RX_DV} \tag{2}$$

where

- GMII_RX_ER, and GMII_RX_DV are logical equivalent signals in GMII standard.

When receiving a valid frame with no error, *RX_CTRL = True* is generated as a logic high on the rising edge of RX_CLK and *RX_CTRL = False* is generated as a logic high at the falling edge of RX_CLK. When no frame is being received, *RX_CTRL = False* is generated as a logic low on the rising edge of RX_CLK and *RX_CTRL = False* is generated as a logic low on the falling edge of RX_CLK.

The TX_CTRL is treated in a similar manner. During normal frame transmission, the signal stays at a logic high for both edges of GTX_CLK and during the period between frames where no error is indicated, the signal stays low for both edges.

7.4.4.2 1000Mbps Mode Timing

The DP83869HM provides configurable clock skew for the GTX_CLK and RX_CLK to optimize timing across the interface. The transmit and receive paths can be optimized independently. Both the transmit and receive path support 16 programmable RGMII delay modes through register configuration.

The timing paths can either be configured for Aligned mode or Shift mode. In Aligned mode, no clock skew is introduced. In Shift mode, the clock skew can be introduced in 0.5ns increments or in 0.25ns increments (through register configuration). Configuration of the Aligned mode or Shift mode is accomplished through the RGMII Control Register (RGMIICTL), address 32h. In Shift mode, the clock skew can be adjusted using the RGMII Delay Control Register (RGMIIDCTL), address 86h. By default RGMII shift mode will be activated. Both transmit and receive signals will be delayed by 2ns.

7.4.4.3 10 and 100Mbps Mode

When the RGMII interface is operating in the 100Mbps mode, the RGMII clock rate is reduced to 25MHz. For 10Mbps operation, the clock is further reduced to 2.5MHz. In the RGMII 10/100 mode, the transmit clock RGMII TX_CLK is generated by the MAC and the receive clock RGMII RX_CLK is generated by the PHY. During the packet receiving operation, the RGMII RX_CLK may be stretched on either the positive or negative pulse to accommodate the transition from the free-running clock to a data synchronous clock domain. When the speed of the PHY changes, a similar stretching of the positive or negative pulses is allowed. No glitch is allowed on the clock signals during clock speed transitions.

This interface operates at 10 and 100Mbps speeds the same way it does at 1000Mbps mode with the exception that the data may be duplicated on the falling edge of the appropriate clock.

The MAC holds the RGMII TX_CLK low until it makes sure that it is operating at the same speed as the PHY.

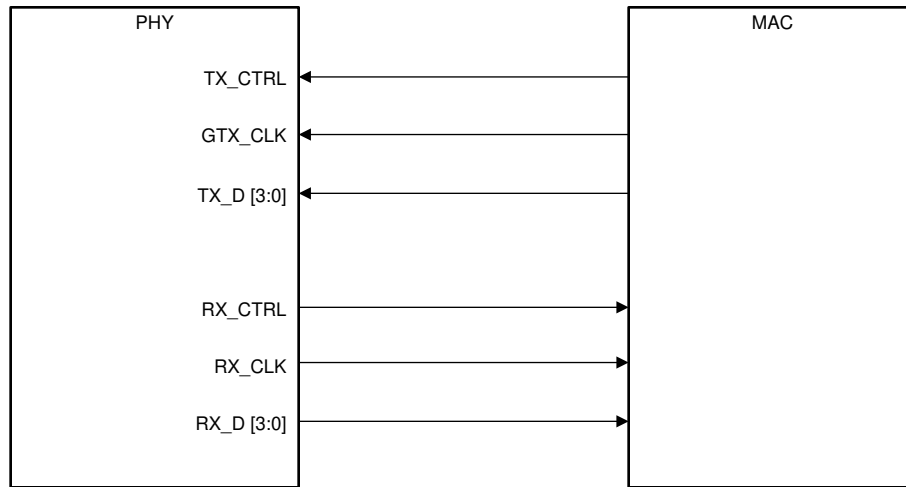

Figure 7-7. RGMII Connections

7.4.5 Media Independent Interface (MII)

DP83869HM also supports MII mode when the PHY is working in 100M and 10M speeds. The user will have to ensure that the PHY links in either 100Mbps or 10Mbps mode. MII mode cannot be used in 1000Mbps mode. When using auto-negotiation to resolve MDI speed, TI recommends to turn off the gigabit speed advertisement through register 0x9 to ensure that the PHY does not link up at 1000Mbps speed. The Media Independent Interface is a synchronous 4-bit wide nibble data interface that connects the PHY to the MAC in 100BASE-FX, 100BASE-TX and 10BASE-Te modes. The RX_ER signal must be properly muxed by setting Register 18h to equal 0xE. The MII is fully compliant with IEEE 802.3-2002 clause 22.

The MII signals are summarized in [Table 7-5](#):

Table 7-5. MII Signals

FUNCTION	PINS
Data Signals	TX_D[3:0]
	RX_D[3:0]
Transmit and Receive Signals	TX_EN, TX_ER
	RX_DV, RX_ER

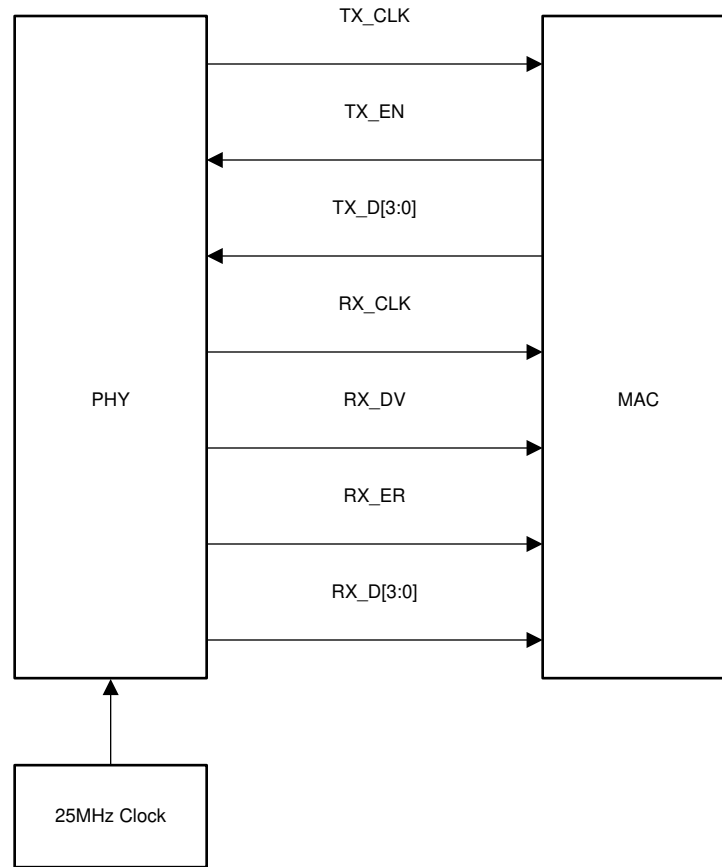

Figure 7-8. MII Signaling

Note

MII mode cannot be enabled via straps alone. Register configuration is also needed.

Steps to configure DP83869HM to MII Mode:

1. Write Reg 0x18 = 0xE
2. Choose MDI Interface
 - a. Copper:
 - i. Write Reg 0x1DF = 0x60
 - b. Fiber:
 - i. Write Reg 0x1DF = 0x62
3. Strap DP83869HM according to [Table 7-6](#)

Table 7-6. Strap Table for MII Mode

PIN NAME	STRAP NAME	PIN #	PIN STRAP CONNECTION
JTAG_TDO / GPIO_1	OPMODE_0	22	OPEN
RX_D3	OPMODE_1	36	MII to Copper: OPEN MII to Fiber: 2.49kΩ Pull-up to VDDIO
RX_D2	OPMODE_2	35	OPEN

7.4.6 Bridge Modes

The DP83869HM supports Bridge modes to translate data between two MAC interface types. Bridge mode is activated through straps or register configuration. The two types of Bridge mode supported by DP83869HM are:

- RGMII-to-SGMII mode
- SGMII-to-RGMII mode

7.4.6.1 RGMII-to-SGMII Mode

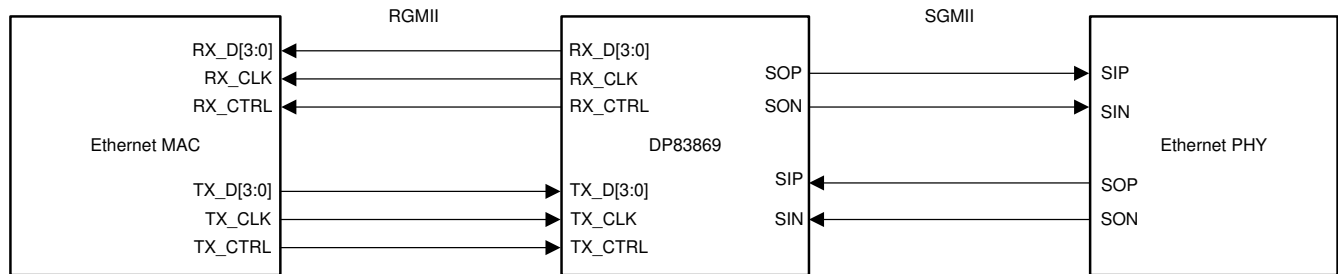

Figure 7-9. DP83869HM RGMII-to-SGMII Bridge

In RGMII-to-SGMII mode Ethernet MAC is connected to the RGMII pins of the DP83869HM and PHY is connected to the SGMII pins of the DP83869. In this mode, DP83869HM will configure SGMII in Auto Mode. In Auto mode, the RGMII side will automatically adjust to the link-up speed on the SGMII side. In case where the PHY is does not have a link, the RGMII clock frequency will default to 2.5MHz.

After auto-negotiation is completed on the PHY side, the link capabilities are communicated to DP83869HM over the SGMII interface. However, this information is conveyed to the Ethernet MAC through RGMII Inband signaling and RX_CLK adjustment. The MAC can also read this information from the DP83869.

In Bridge mode, the DP83869HM SMI will act as slave mode to MAC.

7.4.6.2 SGMII-to-RGMII Mode

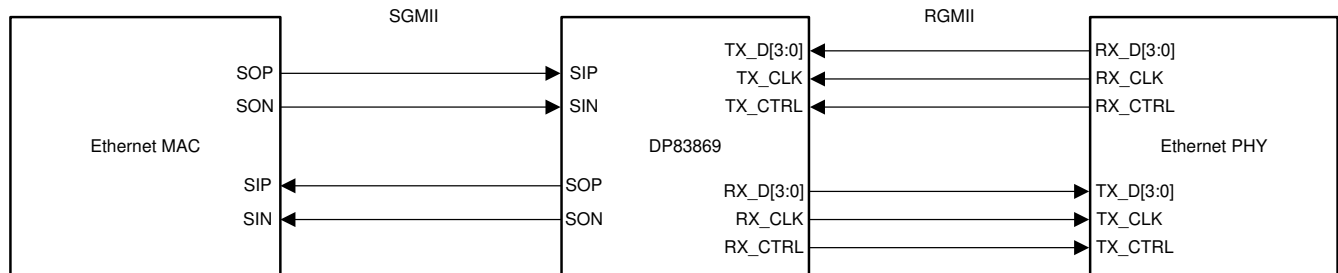

Figure 7-10. DP83869HM SGMII-to-RGMII Bridge

In SGMII-to-RGMII mode, Ethernet MAC is connected to the SGMII pins of the DP83869HM and PHY is connected to the RGMII pins of the DP83869. In this mode, DP83869HM will configure SGMII in Auto. In Auto mode, SGMII will adapt the link speed based on RGMII.

After auto-negotiation is completed on the PHY side, the link capabilities are communicated to DP83869HM over the RGMII interface. However, this information needs to be conveyed to the Ethernet MAC as well. The MAC can read this information from the DP83869HM through the registers.

In SGMII-to-RGMII Bridge mode, the DP83869 will act as RGMII MAC for the Ethernet PHY. The DP83869 RX pins will act as output pins from the DP83869 to the Ethernet PHY TX pins, and the DP83869 TX pins will act as input pins for the Ethernet PHY RX pins.

In both Bridge modes, PRBS mode of the PHY is not applicable and should not be used.

LEDs, if used, will indicate status on the RGMII side in both Bridge Modes.

7.4.7 Media Convertor Mode

In media convertor mode, DP83869HM will translate data between copper and fiber interface for 1000M and 100M speeds. Media convertor mode can be activated through the straps. The DP83869HM supports Unmanaged Media Convertor mode.



Figure 7-11. Media Convertor Mode

In Unmanaged mode, Media Convertor can still be activated via straps but register configuration options are also used for enhanced features like changing LED configuration, Capabilities programming broadcasted in Auto-Neg etc may need configuration and are supported through register programming. Register access to the PHY is retained. This provides additional flexibility to use other features supported by the PHY.

Copper interface will support auto-negotiation, but the user will have to ensure that the speed negotiated on the copper side matches the speed fixed on the fiber side. In cases of speed mismatch between copper and fiber, interface data transmission will not be successful.

The DP83869HM also supports Link Loss Pass Through in 100M mode. In a network containing two media converters where the link is dropped on one end of the system, a link loss indication is passed through all the way to the far end. The Link Loss Pass-Through is enabled or disabled through straps. An example is shown in Figure 7-12.

1. A fault occurs on copper link at position 1 at Near End Link Partner.
2. Media Converter will disable Fiber TX link at position 2.
3. The Media Converter in the system will lose link at position 3.
4. The second Media Converter disables copper link and the far end link partner loses the copper link.



Figure 7-12. Link Loss Pass-Through

7.4.8 Register Configuration for Operational Modes

The operational modes of DP83869HM are configured through the OPMODE[0], OPMODE[1], OPMODE[2] straps. When operational modes are changed through register access, additional configurations are necessary apart from 1DFh. The following sections contain necessary information for changing operational modes through the registers. For modes not listed below, only configuring register 1DFh is sufficient.

7.4.8.1 RGMII-to-Copper Ethernet Mode

Required register configuration when switching to RGMII-to-Copper mode using software:

- Write 0x0040 to register 1DFh // Set Operation Mode to RGMII to Copper
- Write 0x1140 to register 0h // Reset BMCR
- Write 0x01E1 to register 4h // Advertise 100Base-TX and 10Base-T ability
- Write 0x0300 to register 9h // Reset GEN_CFG1
- Write 0x5048 to register 10h // Reset PHY_CONTROL
- Write 0x4000 to register 1Fh // Software Reset

7.4.8.2 RGMII-to-1000Base-X Mode

- Write 0x0041 to register 1DFh // Set Operation Mode to RGMII to 1000Base-X
- Write 0x1140 to register C00h // Reset FX_CTRL
- Write 0x4000 to register 1Fh // Software Reset

7.4.8.3 RGMII-to-100Base-FX Mode

- Write 0x0042 to register 1DFh // Set Operation Mode to RGMII to 100Base-FX
- Write 0x2100 to register C00h // Set Speed to 100 Mbps
- Write 0x4000 to register 1Fh // Software Reset

7.4.8.4 RGMII-to-SGMII Bridge Mode

- Write 0x0043 to register 1DFh // Set Operation Mode to RGMII-to-SGMII.
- Write 0x1140 to register C00h // Reset FX_CTRL
- Write 0x4000 to register 1Fh // Software Reset

7.4.8.5 1000M Media Convertor Mode

- Write 0x0044 to register 1DFh // Set Operation Mode to 1000Base-T to 1000Base-X
- Write 0x1140 to register 0h // Reset BMCR
- Write 0x5048 to register 10h // Reset PHY_CONTROL
- Write 0x1140 to register C00h // Reset FX_CTRL
- Write 0x4000 to register 1Fh // Software Reset

7.4.8.6 100M Media Convertor Mode

- Write 0x0045 to register 1DFh // Set Operation Mode to 100Base-T to 100Base-FX
- Write 0x1140 to register 0h // Reset BMCR
- Write 0x5048 to register 10h // Reset PHY_CONTROL
- Write 0x000E to register 18h // Mux LED_1 to function as RX_ER
- Write 0x4000 to register 1Fh // Software Reset

7.4.8.7 SGMII-to-Copper Ethernet Mode

- Write 0x0046 to register 1DFh // Set Operation Mode to SGMII to Copper
- Write 0x1140 to register 0h // Reset BMCR
- Write 0xB00 to register 9h // Advertise 1000Base-T ability
- Write 0x5048 to register 10h // Reset PHY_CONTROL
- Write 0x1140 to register C00h // Reset FX_CTRL
- Write 0x4000 to register 1Fh // Software Reset

7.4.9 Serial Management Interface

The Serial Management Interface (SMI), provides access to the DP83869HM internal register space for status information and configuration. The SMI is compatible with IEEE 802.3-2002 clause 22. The implemented register set consists of the registers required by the IEEE 802.3, plus several others to provide additional visibility and controllability of the DP83869HM device.

The SMI includes the MDC management clock input and the management MDIO data pin. The MDC clock is sourced by the external management entity, also called Station (STA), and can run at a maximum clock rate of 25MHz. MDC is not expected to be continuous, and can be turned off by the external management entity when the bus is idle.

The MDIO is sourced by the external management entity and by the PHY. The data on the MDIO pin is latched on the rising edge of the MDC clock. The MDIO pin requires a pullup resistor (2.2 kΩ) which, during IDLE and turnaround, pulls MDIO high.

Up to 16 PHYs can share a common SMI bus. To distinguish between the PHYs, a 4-bit address is used. During power-up reset, the DP83869HM latches the PHY_ADD configuration pins to determine its address.

The management entity must not start an SMI transaction in the first cycle after power-up reset. To maintain valid operation, the SMI bus must remain inactive at least one MDC cycle after hard reset is deasserted. In normal MDIO transactions, the register address is taken directly from the management-frame reg_addr field, thus allowing direct access to 32 16-bit registers (including those defined in IEEE 802.3 and vendor specific). The data field is used for both reading and writing. The Start code is indicated by a <01> pattern. This pattern makes sure that the MDIO line transitions from the default idle line state. Turnaround is defined as an idle bit time inserted between the Register Address field and the Data field. To avoid contention during a read transaction, no device may actively drive the MDIO signal during the first bit of turnaround. The addressed DP83869HM drives the MDIO with a zero for the second bit of turnaround and follows this with the required data. Figure 7-13 shows the timing relationship between MDC and the MDIO as driven and received by the Station (STA) and the DP83869HM (PHY) for a typical register read access.

For write transactions, the station-management entity writes data to the addressed DP83869, thus eliminating the requirement for MDIO turnaround. The turnaround time is filled by the management entity by inserting <10>. Figure 7-13 shows the timing relationship for a typical MII register write access. The frame structure and general read and write transactions are shown in Table 7-7, Figure 7-13, and Figure 7-14.

Table 7-7. Typical MDIO Frame Format

TYPICAL MDIO FRAME FORMAT	<idle><start><op code><device addr><reg addr><turnaround><data><idle>
Read Operation	<idle><01><10><AAAA><RRRR><Z0><xxxx xxxx xxxx xxxx><idle>
Write Operation	<idle><01><01><AAAA><RRRR><10><xxxx xxxx xxxx xxxx><idle>

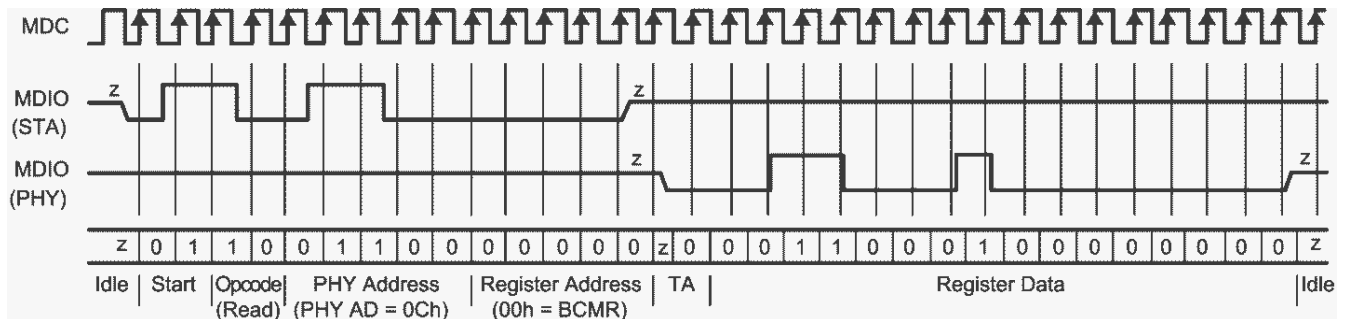

Figure 7-13. Typical MDC/MDIO Read Operation

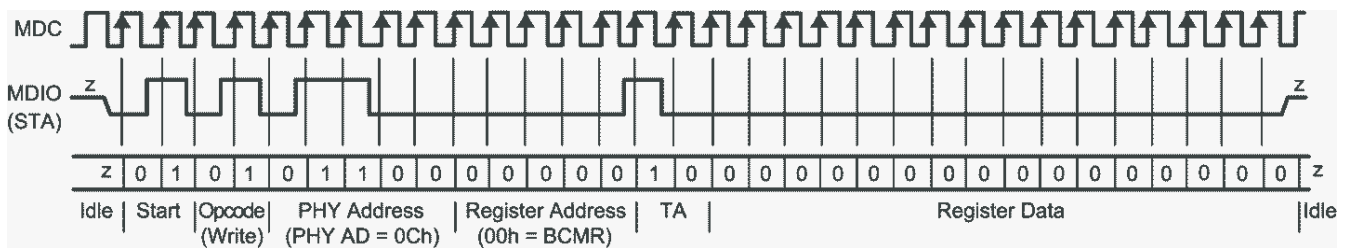

Figure 7-14. Typical MDC/MDIO Write Operation

7.4.9.1 Extended Register Space Access

The DP83869HM's SMI function supports read or write access to the extended register set using registers REGCR (0x0D) and ADDAR (0x0E) and the MDIO Manageable Device (MMD) indirect method defined in IEEE 802.3ah Draft for clause 22 for accessing the clause 45 extended register set.

The standard register set, MDIO registers 0 to 31, is accessed using the normal direct-MDIO access or the indirect method, except for register REGCR (0x0D) and ADDAR (0x0E), which is accessed only using the normal MDIO transaction. The SMI function ignores indirect accesses to these registers.

REGCR (0x0D) is the MDIO Manageable MMD access control. In general, register REGCR(4:0) is the device address (DEVAD) that directs any accesses of ADDAR (0x0E) register to the appropriate MMD.

The PHY'S supports one MMD device address. The vendor-specific device address DEVAD[4:0] = 11111 is used for general MMD register accesses.

All accesses through registers REGCR and ADDAR must use the correct DEVAD. Transactions with other DEVAD are ignored. REGCR[15:14] holds the access function: address (00), data with no post increment (01), data with post increment on read and writes (10) and data with post increment on writes only (11).

Table 7-8. REGCR DEVAD Functions

REGCR[15:14]	FUNCTION
00	Accesses to register ADDAR modify the extended register 'set address' register. This address register must always be initialized to access any of the registers within the extended register set.
01	Accesses to register ADDAR access the register within the extended register set selected by the value in the address register.
10	Access to register ADDAR access the register within the extended register set selected by the value in the address register. After that access is complete, for both reads and writes, the value in the address register is incremented.
11	Access to register ADDAR access the register within the extended register set selected by the value in the address register. After that access is complete, for write accesses only, the value in the address register is incremented. For read accesses, the value of the address register remains unchanged.

The following sections describe how to perform operations on the extended register set using register REGCR and ADDAR. The descriptions use the device address for general MMD register accesses (DEVAD[4:0] = 11111).

7.4.9.1.1 Read (No Post Increment) Operation

To read a register in the extended register set:

INSTRUCTION	EXAMPLE: READ 0x0170
1. Write the value 0x001F (address function field = 00, DEVAD = 31) to register REGCR.	Write register 0x0D to value 0x001F
2. Write the desired register address to register ADDAR.	Write register 0x0E to value 0x0170
3. Write the value 0x401F (data, no post increment function field = 01, DEVAD = 31) to register REGCR.	Write register 0x0D to value 0x401F
4. Read the content of the desired extended register set register to register ADDAR.	Read register 0x0E

Subsequent reads from register ADDAR (step 4) continue reading the register selected by the value in the address register.

Note

Steps (1) and (2) can be skipped if the address register was previously configured.

7.4.9.1.2 Write (No Post Increment) Operation

To write a register in the extended register set:

INSTRUCTION	EXAMPLE: SET REG 0x0170 = 0C50
1. Write the value 0x001F (address function field = 00, DEVAD = 31) to register REGCR (0x0D).	Write register 0x0D to value 0x001F
2. Write the desired register address to register ADDAR (0x0E).	Write register 0x0E to value 0x0170
3. Write the value 0x401F (data, no post increment function field = 01, DEVAD = 31) to register REGCR.	Write register 0x0D to value 0x401F
4. Write the content of the desired extended register set register to register ADDAR.	Write register 0x0E to value 0x0C50

Subsequent writes to register ADDAR (step 4) continue to rewrite the register selected by the value in the address register.

Note

Steps (1) and (2) can be skipped if the address register was previously configured.

7.4.10 Auto-Negotiation

All 1000BASE-T PHYs are required to support Auto-Negotiation. The Auto-Negotiation function in 1000BASE-T has three primary purposes:

- Auto-Negotiation of Speed and Duplex Selection
- Auto-Negotiation of Master or Slave Resolution
- Auto-Negotiation of Pause or Asymmetrical Pause Resolution

7.4.10.1 Speed and Duplex Selection - Priority Resolution

The Auto-Negotiation function provides a mechanism for exchanging configuration information between the two ends of a link segment. This mechanism is implemented by exchanging Fast Link Pulses (FLP). FLPs are burst pulses that provide the signaling used to communicate the abilities between two devices at each end of a link segment. For further details regarding Auto-Negotiation, refer to Clause 28 of the IEEE 802.3 specification. The DP83869HM supports 1000BASE-T, 100BASE-TX, and 100BASE-T modes of operation. The process of Auto-Negotiation makes sure that the highest performance protocol is selected (that is, priority resolution) based on the advertised abilities of the Link Partner and the local device.

7.4.10.2 Master and Slave Resolution

If 1000BASE-T mode is selected during the priority resolution, the second goal of Auto-Negotiation is to resolve Master or Slave configuration. The Master mode priority is given to the device that supports multiport nodes, such as switches and repeaters. Single node devices such as DTE or NIC card takes lower Master mode priority.

7.4.10.3 Pause and Asymmetrical Pause Resolution

When Full-Duplex operation is selected during priority resolution, the Auto-Negotiation also determines the Flow Control capabilities of the two link partners. Flow control was originally introduced to force a busy station's Link Partner to stop transmitting data in Full-Duplex operation. Unlike Half-Duplex mode of operation where a link partner could be forced to back off by simply generating collisions, the Full-Duplex operation needed a mechanism to slow down transmission from a link partner in the event that the receiving station's buffers are becoming full. A new MAC control layer was added to handle the generation and reception of Pause Frames. Each MAC Controller has to advertise whether it is capable of processing Pause Frames. In addition, the MAC Controller advertises if Pause frames can be handled in both directions, that is, receive and transmit. If the MAC Controller only generates Pause frames but does not respond to Pause frames generated by a link partner, it is called Asymmetrical Pause. The advertisement of Pause and Asymmetrical Pause capabilities is enabled by writing 1 to bits 10 and 11 of ANAR (register address 4h). The link partner's Pause capabilities is stored in ANLPAR (register address 5h) bits 10 and 11. The MAC Controller has to read from ANLPAR to determine which Pause mode to operate. The PHY layer is not involved in Pause resolution other than simply advertising and reporting of Pause capabilities.

7.4.10.4 Next Page Support

The DP83869HM supports the Auto-Negotiation Next Page protocol as required by IEEE 802.3 clause 28.2.4.1.7. The ANNPTR 7h allows for the configuration and transmission of the Next Page. Refer to clause 28 of the IEEE 802.3 standard for detailed information regarding the Auto-Negotiation Next Page function.

7.4.10.5 Parallel Detection

The DP83869HM supports the Parallel Detection function as defined in the IEEE 802.3 specification. Parallel Detection requires the 10/100Mbps receivers to monitor the receive signal and report link status to the Auto-Negotiation function. Auto-Negotiation uses this information to configure the correct technology in the event

that the Link Partner does not support Auto-Negotiation, yet is transmitting link signals that the 10BASE-T or 100BASE-X PMA recognize as valid link signals.

If the DP83869HM completes Auto-Negotiation as a result of Parallel Detection without Next Page operation, bits 5 and 7 of ANLPAR (register address 5h) are set to reflect the mode of operation present in the Link Partner. Note that bits 4:0 of the ANLPAR are also set to 00001 based on a successful parallel detection to indicate a valid 802.3 selector field. Software may determine that the negotiation is completed through Parallel Detection by reading 0 in bit 0 of ANER (register address 6h) after Auto-Negotiation Complete—bit 5 of BMSR (register address 1h)—is set. If the PHY is configured for parallel detect mode and any condition other than a good link occurs, the parallel detect fault—bit 4 of ANER (register address 6h)—sets.

7.4.10.6 Restart Auto-Negotiation

If a link is established by successful Auto-Negotiation and then lost, the Auto-Negotiation process resumes to determine the configuration for the link. This function ensures that a link can be re-established if the cable becomes disconnected and reconnected. After Auto-Negotiation is completed, it may be restarted at any time by writing 1 to bit 9 of the BMCR (register address 0h). A restart Auto-Negotiation request from any entity, such as a management agent, causes DP83869HM to halt data transmission or link pulse activity until the `break_link_timer` expires. Consequently, the Link Partner goes into link fail mode and the resume Auto-Negotiation. The DP83869HM resumes Auto-Negotiation after the `break_link_timer` has expired by transmitting FLP (Fast Link Pulse) bursts.

7.4.10.7 Enabling Auto-Negotiation Through Software

If Auto-Negotiation is disabled by MDIO access, and the user desires to restart Auto-Negotiation, this could be accomplished by software access. Bit 12 of BMCR (register address 0h) should be cleared and then set for Auto-Negotiation operation to take place.

If Auto-Negotiation is disabled by strap option, Auto-Negotiation cannot be re-enabled.

7.4.10.8 Auto-Negotiation Complete Time

Parallel detection and Auto-Negotiation typically take 2-3 seconds to complete. In addition, Auto-Negotiation with next page exchange takes approximately 2-3 seconds to complete, depending on the number of next pages exchanged. Refer to Clause 28 of the IEEE 802.3 standard for a full description of the individual timers related to Auto-Negotiation.

7.4.10.9 Auto-MDIX Resolution

The DP83869HM can determine if a *straight* or *crossover* cable is used to connect to the link partner. It can automatically re-assign channel A and B to establish link with the link partner, (and channel C and D in 1000BASE-T mode). Auto-MDIX resolution precedes the actual Auto-Negotiation process that involves exchange of FLPs to advertise capabilities. Automatic MDI/MDIX is described in IEEE 802.3 Clause 40, section 40.8.2. It is not a required implementation for 10BASE-T and 100BASE-TX.

Auto-MDIX can be enabled or disabled by strap, using the AMDIX Disable strap, or by register configuration, using bit 6 of the PHYCR register (address 10h). When Auto-MDIX is disabled, the PMA is forced to either MDI (*straight*) or MDIX (*crossed*). Manual configuration of MDI or MDIX can also be accomplished by strap, using the Force MDI/X strap, or by register configuration, using bit 5 of the PHYCR register.

For 10/100, Auto-MDIX is independent of Auto-Negotiation. Auto-MDIX works in both Auto-Negotiation mode and manual forced speed mode.

7.5 Programming

7.5.1 Strap Configuration

The DP83869HM uses many of the functional pins as strap options to place the device into specific modes of operation. The values of these pins are sampled at power up or hard reset. During software resets, the strap options are internally reloaded from the values sampled at power up or hard reset. The strap option pin assignments are defined below.

Configuration of the device can be done through the strap pins or through the management register interface. A pullup resistor and/or a pulldown resistor of suggested values can be used to set the voltage ratio of the strap pin input and the supply to select one of the possible selected modes.

The MAC interface pins must support I/O voltages of 3.3V, 2.5V, and 1.8V. As the strap inputs are implemented on these pins, the straps must also support operation at 3.3V, 2.5V, and 1.8V supplies depending on what voltage was selected for I/O. RX_D0 and RX_D1 pins are 4 level strap pins. All other strap pins have two levels.

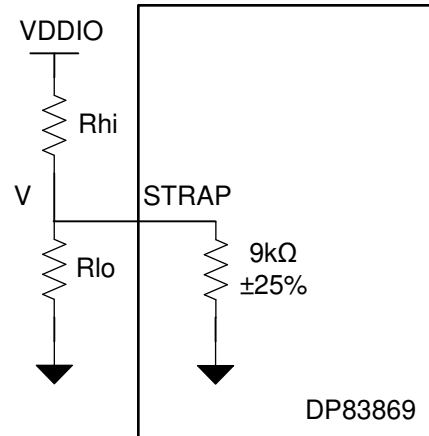

Figure 7-15. Strap Circuit

Table 7-9. 4-Level Strap Resistor Ratio

MODE	TARGET VOLTAGE			IDEAL RESISTORS	
	Vmin (V)	Vtyp (V)	Vmax (V)	Rhi (kΩ)	Rlo (kΩ)
0	0	0	0.093 × VDDIO	OPEN	OPEN
1	0.136 × VDDIO	0.165 × VDDIO	0.184 × VDDIO	10	2.49
2	0.219 × VDDIO	0.255 × VDDIO	0.280 × VDDIO	5.76	2.49
3	0.6 × VDDIO	0.783 × VDDIO	0.888 × VDDIO	2.49	OPEN

Table 7-10. 2-Level Strap Resistor Ratio

MODE	TARGET VOLTAGE			IDEAL RESISTORS	
	Vmin (V)	Vtyp (V)	Vmax (V)	Rhi (kΩ)	Rlo (kΩ)
0	0		0.18 × VDDIO	OPEN	2.49
1	0.5 × VDDIO		0.88 × VDDIO	2.49	OPEN

7.5.1.1 Straps for PHY Address

Table 7-11. PHY Strap Table

PIN NAME	STRAP NAME	PIN #	DEFAULT	PHY_ADD	
				PHY_ADD1	PHY_ADD0
RX_D0	PHY_ADD[1:0]	33	00	MODE 0	0
				MODE 1	0
				MODE 2	1
				MODE 3	1

Table 7-11. PHY Strap Table (continued)

PIN NAME	STRAP NAME	PIN #	DEFAULT	PHY_ADD3	PHY_ADD2
RX_D1	PHY_ADD[3:2]	34	00	MODE 0	0
				MODE 1	0
				MODE 2	1
				MODE 3	1

7.5.1.2 Strap for DP83869HM Functional Mode Selection

Table 7-12. Functional Mode Strap Table

PIN NAME	STRAP NAME	PIN #	DEFAULT	OPMODE[2]	OPMODE[1]	OPMODE[0]	FUNCTIONAL MODES
JTAG_TDO/ GPIO_1	OPMODE[0]	22	0	0	0	0	RGMII to Copper (1000Base-T/ 100Base-TX/10Base-Te)
				0	0	1	RGMII to 1000Base-X
RX_D3	OPMODE[1]	36	0	0	1	0	RGMII to 100Base-FX
				0	1	1	RGMII-SGMII Bridge Mode
RX_D2	OPMODE[2]	35	0	1	0	0	1000Base-T to 1000Base-X
				1	0	1	100Base-TX to 100Base-FX
				1	1	0	SGMII to Copper (1000Base-T/ 100Base-TX/10Base-Te)
				1	1	1	JTAG for boundary scan

7.5.1.3 LED Default Configuration Based on Device Mode

Based on the strapped OP_MODE, the following table summarizes the default of LED0, LED1 and LED2.

Table 7-13. LED Defaults

OP_MODE[2:0]	Mode Description	LED0 Default	LED1 Default	LED2 Default
000	RGMII to Copper (1000Base-TX/ 100Base-TX/10-T)	10/100M/1G Link-up: Stable ON	1G Link-up: Stable ON	TX and RX Activity
001	RGMII to 1000Base-X	Fiber Link-up: Stable ON	RX Activity	RX Activity
010	RGMII to 100Base-FX	Fiber Link-up: Stable ON	RX Activity	RX Activity
011	RGMII to SGMII	SGMII Link-up from 10/100M/1G: Stable ON	SGMII 1G Link-up: Stable ON	TX and RX Activity
100	Copper to 1000Base-X	Copper Link Status Link established: Stable ON Link dropped to 100M or half duplex: LED blink (error Condition)	Fiber Link established: Stable ON	TX and RX Activity
101	Copper to 100Base-FX	Copper Link Status Link established: Stable ON Link dropped to 100M or half duplex: LED blink (error Condition)	Fiber Link established: Stable ON	TX and RX Activity
110	SGMII to Copper (1000Base-TX/ 100Base-TX/10-T)	10/100M/1G Link-up: Stable ON	1G Link-up: Stable ON	TX and RX Activity

7.5.1.4 Straps for RGMII/SGMII to Copper

Table 7-14. Copper Ethernet Strap Table

PIN NAME	STRAP NAME	PIN #	DEFAULT	ANEG_DIS	ANEGS_EL_1	ANEGS_EL_0	FUNCTION
LED_0	ANEG_DIS	47	0	0	0	0	Auto-negotiation, 1000/100/10 advertised, Auto MDI-X
				0	0	1	Auto-negotiation, 1000/100 advertised, Auto MDI-X
LED_1	ANEGSEL_0	46	0	0	1	0	Auto-negotiation, 100/10 advertised, Auto-MDI-X
				0	1	1	NA
				1	0	0	NA
LED_2	ANEGSEL_1	45	0	1	0	1	NA
				1	1	0	Forced 100M, full duplex, MDI mode
				1	1	1	Forced 100M, full duplex, MDI-X mode
RX_CTRL	MIRROR_EN	38	0	0		Port Mirroring Disabled	
				1		Port Mirroring Enabled	

7.5.1.5 Straps for RGMII to 1000Base-X

Table 7-15. 1000Base-X Strap Table

PIN NAME	STRAP NAME	PIN #	DEFAULT		
LED_0	ANEG_DIS	47	0	0	Fiber Auto-negotiation ON
				1	Fiber Force mode
LED_1	ANEGSEL_0	46	0	0	Signal Detect disable on Pin 24
				1	Configure Pin 24 as Signal Detect Pin

7.5.1.6 Straps for RGMII to 100Base-FX

Table 7-16. 100Base-X Strap Table

PIN NAME	STRAP NAME	PIN #	DEFAULT		
LED_1	ANEGSEL_0	46	0	0	Signal Detect disable on Pin 24
				1	Configure Pin 24 as Signal Detect Pin

7.5.1.7 Straps for Bridge Mode (SGMII-RGMII)

Table 7-17. Bridge Mode Strap Table

PIN NAME	STRAP NAME	PIN #	DEFAULT		
RX_CTRL	MIRROR_EN	38	0	0	SGMII to RGMII (SGMII : MAC I/F, RGMII : Phy I/F)
				1	RGMII to SGMII (RGMII : MAC I/F, SGMII : Phy I/F)

7.5.1.8 Straps for 100M Media Convertor

Table 7-18. 100M Media Convertor Strap Table

PIN NAME	STRAP NAME	PIN #	DEFAULT		
LED_1	ANEGSEL_0	46	0	ANEGSEL_1	ANEGSEL_0

Table 7-18. 100M Media Converter Strap Table (continued)

PIN NAME	STRAP NAME	PIN #	DEFAULT			
LED_2	ANEGSEL_1	45	0	0	0	Copper : Auto-negotiation (100/10 Advertised), Auto MDIX
				1	1	Copper : Auto Negotiation (100 Advertised), Auto MDIX
RX_CTRL	MIRROR_EN	38	0	0		Copper: Mirror Disable
				1		Copper: Mirror Enable
RX_CLK	LINK_LOSS	32	0	0		Link Loss Pass Thru Enabled
				1		Link Loss Pass Thru Disabled

7.5.1.9 Straps for 1000M Media Converter**Table 7-19. 1000M Media Strap Table**

PIN NAME	STRAP NAME	PIN #	DEFAULT			
LED_0	ANEG_DIS	47	0	0		Fiber Auto Negotiation
				1		Fiber Force Mode
LED_1	ANEGSEL_0	46	0	ANEGSEL_1	ANEGSEL_0	
LED_2	ANEGSEL_1	45	0	0	0	Copper : Auto-negotiation (1000/100 Advertised), Auto MDIX
				1	1	Copper : Auto Negotiation (1000 Advertised), Auto MDIX
RX_CTRL	MIRROR_EN	38	0	0		Copper: Mirror Disable
				1		Copper: Mirror Enable
RX_CLK	LINK_LOSS	32	0	0		Link Loss Pass Thru Enabled
				1		Link Loss Pass Thru Disabled

Note

In 1000M media converter mode, Cu Auto-negotiation does not downgrade to 100Mbps if LP supports only 100Mbps and link will fail.

7.5.2 LED Configuration

The DP83869HM supports three configurable Light Emitting Diode (LED) pins: LED_0, LED_1, and LED_2. Several functions can be multiplexed onto the LEDs for different modes of operation. Based on the strapped OPMODE[2:0] the default function of each LED might change. Please see "LED Default Configuration Based on Device Mode" for more information. LED operation mode can be selected using the LED_CFG1 register (address 18h).

Because the LED output pins are also used as straps, the external components required for strapping and LED usage must be considered to avoid contention. Specifically, when the LED outputs are used to drive LEDs directly, the active state of each output driver is dependent on the logic level sampled by the corresponding AN input upon power up or reset.

If a given strap input is resistively pulled low then the corresponding output is configured as an active high driver. Conversely, if a given strap input is resistively pulled high, then the corresponding output is configured as an active low driver.

Refer to [Figure 7-16](#) for an example of strap connections to external components. In this example, the strapping results in Mode 0 for LED_0 and Mode 1 for LED_1.

The adaptive nature of the LED outputs helps to simplify potential implementation issues of these dual purpose pins.

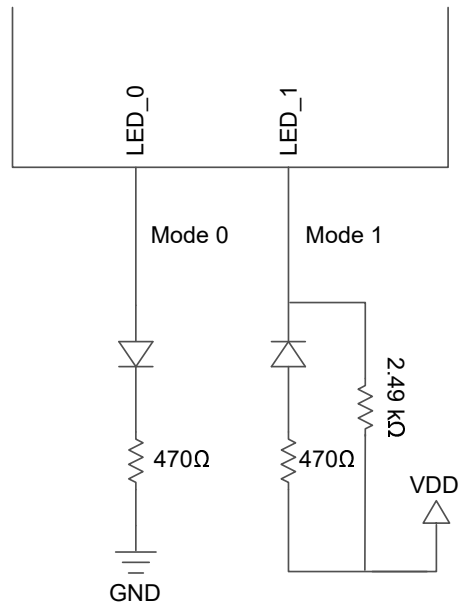

Figure 7-16. Example Strap Connections

The following conditions must be accounted when using LEDs:

- In RGMII-to-SGMII bridge mode with force speeds, Link LED function cannot be used.
- In both Bridge modes, LEDs can be configured to indicate TX only or RX only activity. LED will indicate activity with respect to RGMII when the PHY is in Bridge mode.
- In 1000Mbps media convertor mode, the link LED corresponds to 1000M link on Copper interface. If link speed is changed then Link LED cannot be used.
- In 100Mbps media convertor mode, the link LED corresponds to 100M link on Copper interface. If link speed is changed then Link LED cannot be used.

7.5.3 Reset Operation

The DP83869HM needs external control over RESET_N pin during power up. If RESET_N pin is connected to host controller, then the PHY should be held in reset for a minimum of 200ms after the last supply powers up as shown in . If host controller cannot be [Figure 6-1](#) connected to RESET_N then a 100Ω resistor and 47μF capacitor are required to be connected in series between RESET_N pin and ground as shown in [Figure 7-17](#). During normal operation, the device can be reset by a hardware or software reset.

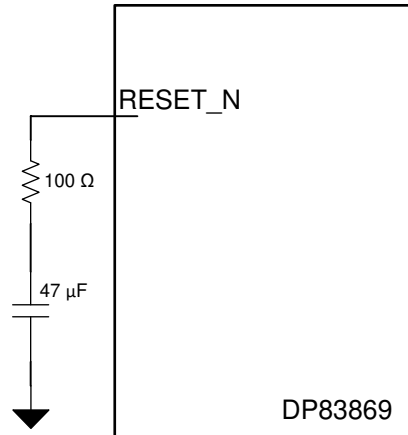

Figure 7-17. RESET_N Circuit

7.5.3.1 Hardware Reset

A hardware reset is accomplished by applying a low pulse, with a duration of at least 1 μ s, to the RESET_N pin. This resets the device such that all registers are reinitialized to default values and the hardware configuration values are re-latched into the device (similar to the power up or reset operation).

7.5.3.2 IEEE Software Reset

An IEEE registers software reset is accomplished by setting the reset bit (bit 15) of the BMCR register (address 0h). This bit resets the IEEE-defined standard registers.

7.5.3.3 Global Software Reset

A global software reset is accomplished by setting bit 15 of register CTRL (address 1Fh) to 1. This bit resets all the internal circuits in the PHY including IEEE-defined registers and all the extended registers. The global software resets the device such that all registers are reset to default values and the hardware configuration values are maintained.

7.5.3.4 Global Software Restart

A global software restart is accomplished by setting bit 14 of register CTRL (1Fh) to 1. This action resets all the PHY circuits except the registers in the Register File.

7.6 Register Maps

For Fiber Operations (RGMII-to-1000Base-X and RGMII-to-100Base-FX), Fiber register location 0Cxxh get mapped to 0xxxxh address location to comply with IEEE Specifications.

7.6.1 DP83869 Registers

Table 7-20 lists the memory-mapped registers for the DP83869 registers. All register offset addresses not listed in Table 7-20 should be considered as reserved locations and the register contents should not be modified.

Table 7-20. DP83869 Registers

Offset	Acronym	Register Name	Section
0h	BMCR	Basic Mode Control Register	Go
1h	BMSR	Basic Mode Status Register	Go
2h	PHYIDR1	PHY Identifier Register #1	Go
3h	PHYIDR2	PHY Identifier Register #2	Go
4h	ANAR	Auto-Negotiation Advertisement Register	Go
5h	ALNPAR	Auto-Negotiation Link Partner Ability Register	Go
6h	ANER	Auto-Negotiate Expansion Register	Go
7h	ANNPTR	Auto-Negotiation Next Page Transmit Register	Go
8h	ANLNPTR	Auto-Negotiation Link Partner Next Page Receive Register	Go
9h	GEN_CFG1	Configuration Register 1	Go
Ah	GEN_STATUS1	Status Register 1	Go
Dh	REGCR	Register Control Register	Go
Eh	ADDAR	Address or Data Register	Go
Fh	1KSCR	1000BASE-T Status Register	Go
10h	PHY_CONTROL	PHY Control Register	Go
11h	PHY_STATUS	PHY Status Register	Go
12h	INTERRUPT_MASK	MII Interrupt Control Register	Go
13h	INTERRUPT_STATUS	Interrupt Status Register	Go
14h	GEN_CFG2	Configuration Register 2	Go
15h	RX_ERR_CNT		Go
16h	BIST_CONTROL	BIST Control Register	Go
17h	GEN_STATUS2	Status Register 2	Go
18h	LEDS_CFG1	LED Configuration Register 1	Go
19h	LEDS_CFG2	LED Configuration Register 2	Go
1Ah	LEDS_CFG3	LED Configuration Register 3	Go
1Eh	GEN_CFG4	Configuration Register 3	Go
1Fh	GEN_CTRL	Control Register	Go
25h	ANALOG_TEST_CTRL	Testmode Channel Control Register	Go
2Ch	GEN_CFG_ENH_AMIX		Go
2Dh	GEN_CFG_FLD		Go
2Eh	GEN_CFG_FLD_THR		Go
31h	GEN_CFG3	Configuration Register 4	Go
32h	RGMII_CTRL	RGMII Control Register	Go
33h	RGMII_CTRL2		Go
37h	SGMII_AUTO_NEG_STATUS	SGMII Autonegotiation Status Register	Go
39h	PRBS_TX_CHK_CTRL		Go
3Ah	PRBS_TX_CHK_BYTE_CNT		Go

Table 7-20. DP83869 Registers (continued)

Offset	Acronym	Register Name	Section
43h	G_100BT_REG0		Go
4Fh	SERDES_SYNC_STS		Go
55h	G_1000BT_PMA_STATUS	Skew FIFO Status Register	Go
6Eh	STRAP_STS	Strap Status Register	Go
71h	DBG_PRBS_BYTE_CNT		Go
72h	DBG_PRBS_ERR_CNT		Go
7Bh	DBG_PKT_LEN_PRBS		Go
7Ch	DBG_IPG_LEN		Go
86h	ANA_RGMII_DLL_CTRL	RGMII Delay Control Register	Go
C6h	ANA_PLL_PROG_PI		Go
D6h	SGMII_TESTMODE		Go
E9h	DSP_HYBRID_CFG2		Go
FEh	LOOPCR	Loopback Configuration Register	Go
134h	RXF_CFG		Go
135h	RXF_STATUS		Go
136h	RXF_PMATCH_DATA1		Go
137h	RXF_PMATCH_DATA2		Go
138h	RXF_PMATCH_DATA3		Go
139h	RXF_SCRON_PASS1		Go
13Ah	RXF_SCRON_PASS2		Go
13Bh	RXF_SCRON_PASS3		Go
13Ch	RXF_PATTERN_1		Go
13Dh	RXF_PATTERN_2		Go
13Eh	RXF_PATTERN_3		Go
13Fh	RXF_PATTERN_4		Go
140h	RXF_PATTERN_5		Go
141h	RXF_PATTERN_6		Go
142h	RXF_PATTERN_7		Go
143h	RXF_PATTERN_8		Go
144h	RXF_PATTERN_9		Go
145h	RXF_PATTERN_10		Go
146h	RXF_PATTERN_11		Go
147h	RXF_PATTERN_12		Go
148h	RXF_PATTERN_13		Go
149h	RXF_PATTERN_14		Go
14Ah	RXF_PATTERN_15		Go
14Bh	RXF_PATTERN_16		Go
14Ch	RXF_PATTERN_17		Go
14Dh	RXF_PATTERN_18		Go
14Eh	RXF_PATTERN_19		Go
14Fh	RXF_PATTERN_20		Go
150h	RXF_PATTERN_21		Go
151h	RXF_PATTERN_22		Go
152h	RXF_PATTERN_23		Go
153h	RXF_PATTERN_24		Go

Table 7-20. DP83869 Registers (continued)

Offset	Acronym	Register Name	Section
154h	RXF_PATTERN_25		Go
155h	RXF_PATTERN_26		Go
156h	RXF_PATTERN_27		Go
157h	RXF_PATTERN_28		Go
158h	RXF_PATTERN_29		Go
159h	RXF_PATTERN_30		Go
15Ah	RXF_PATTERN_31		Go
15Bh	RXF_PATTERN_32		Go
15Ch	RXF_PATTERN_BYTE_MASK_1		Go
15Dh	RXF_PATTERN_BYTE_MASK_2		Go
15Eh	RXF_PATTERN_BYTE_MASK_3		Go
15Fh	RXF_PATTERN_BYTE_MASK_4		Go
16Fh	10M_SGMII_CFG		Go
170h	IO_MUX_CFG		Go
172h	IO_MUX_GPIO_CTRL2		Go
180h	TDR_GEN_CFG1		Go
181h	TDR_GEN_CFG2		Go
182h	TDR_SEG_DURATION1		Go
183h	TDR_SEG_DURATION2		Go
184h	TDR_GEN_CFG3		Go
185h	TDR_GEN_CFG4		Go
190h	TDR_PEAKS_LOC_A_0_1		Go
191h	TDR_PEAKS_LOC_A_2_3		Go
192h	TDR_PEAKS_LOC_A_4_B_0		Go
193h	TDR_PEAKS_LOC_B_1_2		Go
194h	TDR_PEAKS_LOC_B_3_4		Go
195h	TDR_PEAKS_LOC_C_0_1		Go
196h	TDR_PEAKS_LOC_C_2_3		Go
197h	TDR_PEAKS_LOC_C_4_D_0		Go
198h	TDR_PEAKS_LOC_D_1_2		Go
199h	TDR_PEAKS_LOC_D_3_4		Go
1A4h	TDR_GEN_STATUS		Go
1A5h	TDR_PEAKS_SIGN_A_B		Go
1A6h	TDR_PEAKS_SIGN_C_D		Go
1A8h	DBG_PRBS_PKT_CNT_1		Go
1A9h	DBG_PRBS_PKT_CNT_2		Go
1DFh	OP_MODE_DECODE		Go
1E0h	GPIO_MUX_CTRL		Go
1ECh	MC_LINK_LOSS		Go
C00h	FX_CTRL	Fiber Control Register	Go
C01h	FX_STS	Fiber Status Register	Go
C02h	FX_PHYID1	Fiber PHYID Register 1	Go
C03h	FX_PHYID2	Fiber PHYID Register 2	Go
C04h	FX_ANADV	Fiber Autonegotiation Advertisement Register	Go
C05h	FX_LPABL	Fiber Link Partner Ability Register	Go

Table 7-20. DP83869 Registers (continued)

Offset	Acronym	Register Name	Section
C06h	FX_ANEXP	Fiber Autonegotiation Expansion Register	Go
C07h	FX_LOCNP	Fiber LOC Next Page Register	Go
C08h	FX_LPNP	Fiber Link Partner Next Page Register	Go
C10h	CFG_FX_CTRL0	Fiber Signal Detect	Go
C18h	FX_INT_EN	Fiber Interrupt Enable Register	Go
C19h	FX_INT_STS	Fiber Interrupt Status Register	Go

Complex bit access types are encoded to fit into small table cells. [Table 7-21](#) shows the codes that are used for access types in this section.

Table 7-21. DP83869 Access Type Codes

Access Type	Code	Description
Read Type		
R	R	Read
RC	R C	Read to Clear
RH	R H	Read Set or cleared by hardware
Write Type		
W	W	Write
W1C	W 1C	Write 1 to clear
WoP	W	Write
WtoPH	W	Write
Reset or Default Value		
-n		Value after reset or the default value

7.6.1.1 BMCR Register (Offset = 0h) [Reset = 1140h]

BMCR is shown in [Table 7-22](#).

Return to the [Summary Table](#).

IEEE defined register to control PHY functionality.

Table 7-22. BMCR Register Field Descriptions

Bit	Field	Type	Reset	Description
15	RESET	R/W	0h	This bit controls the MII reset function. This bit is self cleared after reset is completed. 0h = Normal Operation 1h = Reset.
14	MII_LOOPBACK	R/W	0h	This bit controls the MII Loopback. When enabled, this will send data back to the MAC 0h = Disable 1h = Enable
13	SPEED_SEL_LSB	R/W	0h	Speed selection bits LSB[13] and MSB[6] are used to control the data rate of the ethernet link when auto-negotiation is disabled. 0h = 10Mbps 1h = 100Mbps 2h = 1000Mbps 3h = Reserved

Table 7-22. BMCR Register Field Descriptions (continued)

Bit	Field	Type	Reset	Description
12	AUTONEG_EN	R/W	1h	Controls autonegotiation feature 0h = Autonegotiation off 1h = Autonegotiation on
11	PWD_DWN	R	0h	Controls IEEE power down feature 0h = Normal Mode 1h = IEEE power down mode
10	ISOLATE	R/W	0h	Isolate MAC interface pins. 0h = Normal mode 1h = MAC Isolate mode enabled
9	RSTRT_AUTONEG	R/WtoPH	0h	Restart auto-negotiation 0h = Normal mode 1h = Restart autonegotiation
8	DUPLEX_EN	R/W	1h	Controls Half and Full duplex mode of the ethernet link 0h = Half Duplex mode 1h = Full Duplex mode
7	COL_TST	R/W	0h	Controls Collision Signal Test 0h = Disable Collision Signal Test 1h = Enable Collision Signal Test
6	SPEED_SEL_MSB	R	1h	Controls data rate of ethernet link when autonegotiation is disabled. See bit 13 description for morw information.
5-0	RESERVED	R	0h	Reserved

7.6.1.2 BMSR Register (Offset = 1h) [Reset = 7949h]

BMSR is shown in [Table 7-23](#).

Return to the [Summary Table](#).

IEEE defined register to show status of PHY

Table 7-23. BMSR Register Field Descriptions

Bit	Field	Type	Reset	Description
15	RESERVED	R	0h	Reserved
14	100M_FDUP	R	1h	100Base-TX full duplex 0h = PHY not able to perform full duplex 100Base-X 1h = PHY able to perform full duplex 100Base-X
13	100M_HDUP	R	1h	100Base-TX halfduplex 0h = PHY not able to perform half duplex 100Base-X 1h = PHY able to perform half duplex 100Base-X
12	10M_FDUP	R	1h	10Base-Te full duplex 0h = PHY not able to operate at 10Mbps in full duplex 1h = PHY able to operate at 10Mbps in full duplex
11	10M_HDUP	R	1h	10Base-Te half duplex 0h = PHY not able to operate at 10Mbps in half duplex 1h = PHY able to operate at 10Mbps in half duplex
10	RESERVED	R	0h	Reserved
9	RESERVED	R	0h	Reserved
8	EXT_STS	R	1h	Extended status for 1000Base T abilities in register 15 1h = Extended status information in register 0x0F
7	RESERVED	R	0h	Reserved
6	MF_PREAMBLE_SUP	R	1h	Ability to accept management frames with preamble suppressed. 0h = PHY will not accept management frames with preamble suppressed 1h = PHY will accept management frames with preamble suppressed

Table 7-23. BMSR Register Field Descriptions (continued)

Bit	Field	Type	Reset	Description
5	AUTONEG_COMP	R	0h	Status of Autonegotiation 0h = Auto Negotiation process not completed 1h = Auto Negotiation process completed
4	REMOTE_FAULT	RC	0h	Remote fault detection 0h = No remote fault condition detected 1h = Remote fault condition detected
3	AUTONEG_ABL	R	1h	Autonegotiation ability 0h = PHY is not able to perform Auto-Negotiation 1h = PHY is able to perform Auto-Negotiation
2	LINK_STS1	R	0h	Link Status This is latch low and needs to be read twice for valid link up 0h = Link down 1h = Link up
1	JABBER_DTCT	RC	0h	Jabber detected 0h = No jabber detected 1h = Jabber detected
0	EXT_CAPBLTY	R	1h	Extended register capabilities 0h = Basic register set capabilities 1h = Extended register set capabilities

7.6.1.3 PHYIDR1 Register (Offset = 2h) [Reset = 2000h]

PHYIDR1 is shown in [Table 7-24](#).

Return to the [Summary Table](#).

The PHY Identifier Registers #1 and #2 together form a unique identifier for the DP83869. The Identifier consists of a concatenation of the Organizationally Unique Identifier (OUI), the vendor's model number and the model revision number. A PHY may return a value of zero in each of the 32 bits of the PHY Identifier if esired. The PHY Identifier is intended to support network management. Texas Instruments' IEEE assigned OUI is 080028h.

Table 7-24. PHYIDR1 Register Field Descriptions

Bit	Field	Type	Reset	Description
15-0	OUI_MSB	R	2000h	OUI Most Significant Bits: Bits 3 to 18 of the OUI (080028h,) are stored in bits 15 to 0 of this register respectively. Bit numbering for OUI goes from 1 (MSB) to 24(LSB). The most significant two bits of the OUI are ignored (the IEEE standard refers to these as bits 1 and 2).

7.6.1.4 PHYIDR2 Register (Offset = 3h) [Reset = A0F1h]

PHYIDR2 is shown in [Table 7-25](#).

Return to the [Summary Table](#).

Table 7-25. PHYIDR2 Register Field Descriptions

Bit	Field	Type	Reset	Description
15-10	OUI_LSB	R	28h	OUI Least Significant Bits: Bits 19 to 24 of the OUI (080028h) are mapped from bits 15 to 10 of this register respectively.
9-4	MODEL_NUM	R	Fh	Model number: The six bits of vendor model number are mapped from bits 9 to 4 (most significant bit to bit 9).
3-0	REVISION_NUM	R	1h	Revision number: Four bits of the vendor model revision number are mapped from bits 3 to 0 (most significant bit to bit 3). This field will be incremented for all major device changes.

7.6.1.5 ANAR Register (Offset = 4h) [Reset = 0001h]

ANAR is shown in [Table 7-26](#).

Return to the [Summary Table](#).

This register contains the advertised abilities of this device as they will be transmitted to its link partner during Auto-Negotiation. Any writes to this register prior to completion of Auto-Negotiation (as indicated in the Basic Mode Status Register (address 01h) Auto-Negotiation Complete bit, BMSR[5]) should be followed by a renegotiation. This will ensure that the new values are properly used in the Auto-Negotiation.

Table 7-26. ANAR Register Field Descriptions

Bit	Field	Type	Reset	Description
15	NEXT_PAGE_1_ADV	R/W	0h	Next Page Advertisement 0h = Do not advertise desire to send additional SW next pages 1h = Advertise desire to send additional SW next pages
14	RESERVED	R	0h	Reserved
13	REMOTE_FAULT_ADV	R/W	0h	Remote Fault Advertisement 0h = Do not advertise remote fault event detection 1h = Advertise remote fault event detection
12	ANAR_BIT12	R/W	0h	
11	ASYMMETRIC_PAUSE_ADV	R/W	0h	1b = Advertise asymmetric pause ability 0b = Do not advertise asymmetric pause ability
10	PAUSE_ADV	R/W	0h	0h = Do not advertise pause ability 1h = Advertise pause ability
9	G_100BT_4_ADV	R/W	0h	100BT-4 is not supported
8	G_100BTX_FD_ADV	R/W	0h	100Base-TX Full Duplex. Default depends on strap, non strap default '1'. 0h = Do not advertise 100Base-TX Full Duplex ability 1h = Advertise 100Base-TX Full Duplex ability
7	G_100BTX_HD_ADV	R/W	0h	100Base-TX Half Duplex. Default depends on strap, non strap default '1'. 0h = Do not advertise 100Base-TX Half Duplex ability 1h = Advertise 100Base-TX Half Duplex ability
6	G_10BT_FD_ADV	R/W	0h	Default depends on strap, non strap default '1' 0h = Do not advertise 10Base-T Full Duplex ability 1h = Advertise 10Base-T Full Duplex ability
5	G_10BT_HD_ADV	R/W	0h	Default depends on strap, non strap default '1' 0h = Do not advertise 10Base-T Half Duplex ability 1h = Advertise 10Base-T Half Duplex ability
4-0	SELECTOR_FIELD_ADV	R/W	1h	Technology selector field (802.3 == 00001)

7.6.1.6 ALNPAR Register (Offset = 5h) [Reset = 0000h]

ALNPAR is shown in [Table 7-27](#).

Return to the [Summary Table](#).

This register contains the advertised abilities of the Link Partner as received during Auto-Negotiation. The content changes after the successful Auto-Negotiation if Next pages are supported.

Table 7-27. ALNPAR Register Field Descriptions

Bit	Field	Type	Reset	Description
15	NEXT_PAGE_1_LP	R	0h	0h = Link Partner does not advertise desire to send additional SW next pages 1h = Link Partner advertises desire to send additional SW next pages

Table 7-27. ALNPAR Register Field Descriptions (continued)

Bit	Field	Type	Reset	Description
14	ACKNOWLEDGE_1_LP	R	0h	0h = Link Partner does not acknowledge reception of link partner's link code word 1h = Link Partner acknowledges reception of link partner's link code word
13	REMOTE_FAULT_LP	R	0h	0h = Link Partner does not advertise remote fault event detection 1h = Link Partner advertises remote fault event detection
12	RESERVED	R	0h	Reserved
11	ASYMMETRIC_PAUSE_LP	R	0h	0h = Link Partner does not advertise asymmetric pause ability 1h = Link Partner advertises asymmetric pause ability
10	PAUSE_LP	R	0h	0h = Link Partner does not advertise pause ability 1h = Link Partner advertises pause ability
9	G_100BT4_LP	R	0h	0h = Link Partner does not advertise 100Base-T4 ability 1h = Link Partner advertises 100Base-T4 ability
8	G_100BTX_FD_LP	R	0h	0h = Link Partner does not advertise 100Base-TX Full Duplex ability 1h = Link Partner advertises 100Base-TX Full Duplex ability
7	G_100BTX_HD_LP	R	0h	0h = Link Partner does not advertise 100Base-TX Half Duplex ability 1h = Link Partner advertises 100Base-TX Half Duplex ability
6	G_10BT_FD_LP	R	0h	0h = Link Partner does not advertise 10Base-T Full Duplex ability 1h = Link Partner advertises 10Base-T Full Duplex ability
5	G_10BT_HD_LP	R	0h	0h = Link Partner does not advertise 10Base-T Half Duplex ability 1h = Link Partner advertises 10Base-T Half Duplex ability
4-0	SELECTOR_FIELD_LP	R	0h	Technology selector field

7.6.1.7 ANER Register (Offset = 6h) [Reset = 0064h]

ANER is shown in [Table 7-28](#).

Return to the [Summary Table](#).

This register contains additional Local Device and Link Partner status information.

Table 7-28. ANER Register Field Descriptions

Bit	Field	Type	Reset	Description
15-7	RESERVED	R	0h	Reserved
6	RX_NEXT_PAGE_LOC_ABLE	R	1h	0h = Received Next Page storage location is not specified by bit 6.5 1h = Received Next Page storage location is specified by bit 6.5
5	RX_NEXT_PAGE_STOR_LOC	R	1h	0h = Link Partner Next Pages are stored in register 5 1h = Link Partner Next Pages are stored in register 8
4	PRLD_TDCT_FAULE	RC	0h	THIS STATUS IS LH (Latched-High) 0h = A fault has not been detected during the parallel detection process 1h = A fault has been detected during the parallel detection process
3	LP_NP_ABLE	R	0h	0h = Link partner is not able to exchange next pages 1h = Link partner is able to exchange next pages
2	LOCAL_NP_ABLE	R	1h	0h = Local device is not able to exchange next pages 1h = Local device is able to exchange next pages
1	PAGE_RECEIVED_1	RC	0h	THIS STATUS IS LH (Latched-High) 0h = A new page has not been received 1h = A new page has been received
0	LP_AUTONEG_ABLE	R	0h	0h = Link partner is not Auto-Negotiation able 1h = Link partner is Auto-Negotiation able

7.6.1.8 ANNPTR Register (Offset = 7h) [Reset = 2001h]

ANNPTR is shown in [Table 7-29](#).

Return to the [Summary Table](#).

This register contains the next page information sent by this device to its Link Partner during Auto-Negotiation.

Table 7-29. ANNPTR Register Field Descriptions

Bit	Field	Type	Reset	Description
15	NEXT_PAGE_2_ADV	R/W	0h	0h = Do not advertise desire to send additional next pages 1h = Advertise desire to send additional next pages
14	RESERVED	R	0h	Reserved
13	MESSAGE_PAGE	R/W	1h	0h = Current page is an unformatted page 1h = Current page is a message page
12	ACKNOWLEDGE2	R/W	0h	0h = Do not set the ACK2 bit 1h = Set the ACK2 bit
11	TOGGLE	R	0h	Toggles every page. Initial value is !4.11
10-0	MESSAGE_UNFORMATTED	R/W	1h	Contents of the message/unformatted page

7.6.1.9 ANLNPTR Register (Offset = 8h) [Reset = 2001h]

ANLNPTR is shown in [Table 7-30](#).

Return to the [Summary Table](#).

This register contains the next page information sent by the Link Partner during Auto-Negotiation.

Table 7-30. ANLNPTR Register Field Descriptions

Bit	Field	Type	Reset	Description
15	NEXT_PAGE_2_LP	R	0h	0h = Link partner does not advertise desire to send additional next pages 1h = Link partner advertises desire to send additional next pages
14	ACKNOWLEDGE_2_LP	R	0h	0h = Link partner does not acknowledge reception of link code work 1h = Link partner acknowledges reception of link code word
13	MESSAGE_PAGE_LP	R	1h	0h = Received page is an unformatted page 1h = Received page is a message page
12	ACKNOWLEDGE2_LP	R	0h	0h = Link partner does not set the ACK2 bit 1h = Link partner sets the ACK2 bit
11	TOGGLE_LP	R	0h	Toggles every page. Initial value is !5.11
10-0	MESSAGE_UNFORMATTED_LP	R	1h	Contents of the message/unformatted page

7.6.1.10 GEN_CFG1 Register (Offset = 9h) [Reset = 0300h]

GEN_CFG1 is shown in [Table 7-31](#).

Return to the [Summary Table](#).

Table 7-31. GEN_CFG1 Register Field Descriptions

Bit	Field	Type	Reset	Description
15-13	TEST_MODE	R/W	0h	0h = Normal Mode 1h = Test Mode 1 - Transmit Waveform Test 2h = Test Mode 2 - Transmit Jitter Test (Master Mode) 3h = Test Mode 3 - Transmit Jitter Test (Slave Mode) 4h = Test Mode 4 - Transmit Distortion Test 5h = Test Mode 5 - Scrambled MLT3 Idles 6h = Test Mode 6 - Repetitive 0001 sequence 7h = Test Mode 7 - Repetitive {Pulse, 63 zeros}
12	MASTER_SLAVE_MAN_CFG_EN	R/W	0h	1b = Enable manual Master/Slave configuration 0b = Do not enable manual Master/Slave configuration
11	MASTER_SLAVE_MAN_CFG_VAL	R/W	0h	1b = Manual configure as Master 0b = Manual configure as Slave
10	PORT_TYPE	R/W	0h	1b = Multi-port device 0b = Single-port device
9	G_1000BT_FD_ADV	R/W	1h	Default depends on strap 0h = Do not advertise 1000Base-T Full Duplex ability 1h = Advertise 1000Base-T Full Duplex ability
8	G_1000BT_HD_ADV	R/W	1h	Default depends on strap 0h = Do not advertise 1000Base-T Half Duplex ability 1h = Advertise 1000Base-T Half Duplex ability
7	TDR_AUTO_RUN	R/W	0h	TDR Auto Run at link down: 0h = Disable automatic execution of TDR 1h = Enable execution of TDR procedure after link down event
6-0	RESERVED	R	0h	Reserved

7.6.1.11 GEN_STATUS1 Register (Offset = Ah) [Reset = 0000h]

GEN_STATUS1 is shown in [Table 7-32](#).

Return to the [Summary Table](#).

Table 7-32. GEN_STATUS1 Register Field Descriptions

Bit	Field	Type	Reset	Description
15	MS_CONFIG_FAULT	RC	0h	1 = Master/Slave configuration fault detected 0 = No Master/Slave configuration fault detected THIS STATUS IS LH (Latched-High)
14	MS_CONFIG_RES	R	0h	1 = Local PHY configuration resolved to Master 0 = Local PHY configuration resolved to Slave
13	LOC_RCVR_STATUS_1	R	0h	1 = Local receiver is OK 0 = Local receiver is not OK
12	REM_RCVR_STATUS	R	0h	1 = Remote receiver is OK 0 = Remote receiver is not OK
11	LP_1000BT_FD_ABILITY	R	0h	1 = Link partner supports 1000Base-T Full Duplex ability 0 = Link partner does not support 1000Base-T Full Duplex ability
10	LP_1000BT_HD_ABILITY	R	0h	1 = Link partner supports 1000Base-T Half Duplex ability 0 = Link partner does not support 1000Base-T Half Duplex ability
9-8	RESERVED	R	0h	Reserved
7-0	IDLE_ERR_COUNT	R	0h	1000Base-T Idle Error Counter

7.6.1.12 REGCR Register (Offset = Dh) [Reset = 0000h]

REGCR is shown in [Table 7-33](#).

Return to the [Summary Table](#).

This register is the MDIO Manageable MMD access control. In general, register REGCR (4:0) is the device address DEVAD that directs any accesses of the ADDAR (0x000E) register to the appropriate MMD. REGCR also contains selection bits for auto increment of the data register. This register contains the device address

to be written to access the extended registers. Write 0x1F into bits 4:0 of this register. REGCR also contains selection bits (15:14) for the address auto-increment mode of ADDAR.

Table 7-33. REGCR Register Field Descriptions

Bit	Field	Type	Reset	Description
15-14	G_FUNCTION	R/W	0h	00 = Address 01 = Data, no post increment 10 = Data, post increment on read and write 11 = Data, post increment on write only
13-5	RESERVED	R	0h	Reserved
4-0	DEVAD	R/W	0h	Device Address

7.6.1.13 ADDAR Register (Offset = Eh) [Reset = 0000h]

ADDAR is shown in [Table 7-34](#).

Return to the [Summary Table](#).

This register is the address/data MMD register. ADDAR is used in conjunction with REGCR register (0x000D) to provide the access by indirect read/write mechanism to the extended register set.

Table 7-34. ADDAR Register Field Descriptions

Bit	Field	Type	Reset	Description
15-0	ADDR_DATA	R/W	0h	If register 13.15:14 = 00, holds the MMD DEVAD's address register, otherwise holds the MMD DEVAD's data register

7.6.1.14 1KSCR Register (Offset = Fh) [Reset = F000h]

1KSCR is shown in [Table 7-35](#).

Return to the [Summary Table](#).

Table 7-35. 1KSCR Register Field Descriptions

Bit	Field	Type	Reset	Description
15	G_1000BX_FD	R	1h	1 = PHY supports 1000Base-X Full Duplex capability 0 = PHY does not support 1000Base-X Full Duplex capability
14	G_1000BX_HD	R	1h	1 = PHY supports 1000Base-X Half Duplex capability 0 = PHY does not support 1000Base-X Half Duplex capability
13	G_1000BT_FD	R	1h	1 = PHY supports 1000Base-T Full Duplex capability 0 = PHY does not support 1000Base-T Full Duplex capability
12	G_1000BT_HD	R	1h	1 = PHY supports 1000Base-T Half Duplex capability 0 = PHY does not support 1000Base-T Half Duplex capability
11-0	RESERVED	R	0h	Reserved

7.6.1.15 PHY_CONTROL Register (Offset = 10h) [Reset = 5048h]

PHY_CONTROL is shown in [Table 7-36](#).

Return to the [Summary Table](#).

Table 7-36. PHY_CONTROL Register Field Descriptions

Bit	Field	Type	Reset	Description
15-14	TX_FIFO_DEPTH	R/W	1h	FIFO is enabled only in the following modes: 1000BaseT + GMII, 10BaseT/100BaseTX/1000BaseT + SGMI 0h = 3 bytes/nibbles (1000Mbps/Other Speeds) 1h = 4 bytes/nibbles (1000Mbps/Other Speeds) 2h = 6 bytes/nibbles (1000Mbps/Other Speeds) 3h = 8 bytes/nibbles (1000Mbps/Other Speeds)

Table 7-36. PHY_CONTROL Register Field Descriptions (continued)

Bit	Field	Type	Reset	Description
13-12	RX_FIFO_DEPTH	R/W	1h	FIFO is enabled only when SGMII is used 0h = 3 bytes/nibbles (1000Mbps/Other Speeds) 1h = 4 bytes/nibbles (1000Mbps/Other Speeds) 2h = 6 bytes/nibbles (1000Mbps/Other Speeds) 3h = 8 bytes/nibbles (1000Mbps/Other Speeds)
11	RESERVED	R/W	0h	Reserved
10	FORCE_LINK_GOOD	R/W	0h	0h = Do Normal operation 1h = Force Link OK if speed is 1G
9-8	POWER_SAVE_MODE	R/W	0h	0h = Normal mode 1h = Reserved 2h = Active Sleep mode 3h = Passive Sleep mode
7	RESERVED	R/W	0h	Reserved
6-5	MDI_CROSSOVER_MODE	R/W	2h	Default depends on strap 0h = Manual MDI configuration 1h = Manual MDI-X configuration Ah = Enable automatic crossover Bh = Enable automatic crossover
4	DISABLE_CLK_125	R/W	0h	0h = Enable CLK125 1h = Disable CLK125
3	RESERVED	R/W	0h	Reserved
2	RESERVED	R/W	0h	Reserved
1	LINE_DRIVER_INV_EN	R/W	0h	This bit is not applicable in Mirror mode 0h = Do not Invert LD transmission 1h = Invert LD transmission
0	DISABLE_JABBER	R/W	0h	0h = Enable Jabber function 1h = Disable Jabber function

7.6.1.16 PHY_STATUS Register (Offset = 11h) [Reset = 0000h]

PHY_STATUS is shown in [Table 7-37](#).

Return to the [Summary Table](#).

Table 7-37. PHY_STATUS Register Field Descriptions

Bit	Field	Type	Reset	Description
15-14	SPEED_SEL	R	0h	00 = 10Mbps 01 = 100Mbps 10 = 1000Mbps 11 = Reserved
13	DUPLEX_MODE_ENV	R	0h	1 = Full duplex 0 = Half duplex
12	PAGE_RECEIVED_2	RC	0h	1 = Page received 0 = Page not received THIS BIT IS LH (Latched-High), meaning that if this bit detects "Page received," it will hold the value '1' until the register is read. The second read will be '0' if there have been no further "Page received."
11	SPEED_DUPLEX_RESOLVED	R	0h	1 = Auto-Negotiation completed or disabled 0 = Auto-Negotiation enabled and not completed
10	LINK_STATUS_2	R	0h	1 = Link is up 0 = Link is down
9	MDI_X_MODE_CD_1	R	0h	1 = MDI-X 0 = MDI
8	MDI_X_MODE_AB_1	R	0h	1 = MDI-X 0 = MDI
7	SPEED_OPT_STATUS	R	0h	1 = Auto-Negotiation is currently being performed with Speed Optimization masking 1000BaseT abilities (Valid only during Auto-Negotiation) 0 = Auto-Negotiation is currently being performed without Speed Optimization
6	SLEEP_MODE	R	0h	1 = Sleep 0 = Active
5-2	WIRE_CROSS	R	0h	Indicates channels [D,C,B,A] polarity in 1000BT link 1 = Channel polarity is reversed 0 = Channel polarity is normal

Table 7-37. PHY_STATUS Register Field Descriptions (continued)

Bit	Field	Type	Reset	Description
1	DATA_POLARITY	R	0h	1 = 10BT is in normal polarity 0 = 10BT is in reversed polarity
0	JABBER_DTCT_2	R	0h	1 = Jabber 0 = No Jabber

7.6.1.17 INTERRUPT_MASK Register (Offset = 12h) [Reset = 0000h]

INTERRUPT_MASK is shown in [Table 7-38](#).

Return to the [Summary Table](#).

This register implements the Interrupt PHY Specific Control register. The individual interrupt events must be enabled by setting bits in the MII Interrupt Control Register (MICR). If the corresponding enable bit in the register is set, an interrupt is generated if the event occurs.

Table 7-38. INTERRUPT_MASK Register Field Descriptions

Bit	Field	Type	Reset	Description
15	AUTONEG_ERR_INT_EN	R/W	0h	1 = Enable interrupt 0 = Disable interrupt
14	SPEED_CHNG_INT_EN	R/W	0h	1 = Enable interrupt 0 = Disable interrupt
13	DUPLEX_MODE_CHNG_INT_EN	R/W	0h	1 = Enable interrupt 0 = Disable interrupt
12	PAGE_RECEIVED_INT_EN	R/W	0h	1 = Enable interrupt 0 = Disable interrupt
11	AUTONEG_COMP_INT_EN	R/W	0h	1 = Enable interrupt 0 = Disable interrupt
10	LINK_STATUS_CHNG_INT_EN	R/W	0h	1 = Enable interrupt 0 = Disable interrupt
9	EEE_ERR_INT_EN	R/W	0h	1 = Enable interrupt 0 = Disable interrupt
8	FALSE_CARRIER_INT_EN	R/W	0h	1 = Enable interrupt 0 = Disable interrupt
7	ADC_FIFO_OVF_UNF_INT_EN	R/W	0h	1 = Enable interrupt 0 = Disable interrupt
6	MDI_CROSSOVER_CHNG_INT_EN	R/W	0h	1 = Enable interrupt 0 = Disable interrupt
5	SPEED_OPT_EVENT_INT_EN	R/W	0h	1 = Enable interrupt 0 = Disable interrupt
4	SLEEP_MODE_CHNG_INT_EN	R/W	0h	1 = Enable interrupt 0 = Disable interrupt
3	WOL_INT_EN	R/W	0h	1 = Enable interrupt 0 = Disable interrupt
2	XGMII_ERR_INT_EN	R/W	0h	1 = Enable interrupt 0 = Disable interrupt
1	POLARITY_CHNG_INT_EN	R/W	0h	1 = Enable interrupt 0 = Disable interrupt
0	JABBER_INT_EN	R/W	0h	1 = Enable interrupt 0 = Disable interrupt

7.6.1.18 INTERRUPT_STATUS Register (Offset = 13h) [Reset = 0000h]

INTERRUPT_STATUS is shown in [Table 7-39](#).

Return to the [Summary Table](#).

This register contains event status for the interrupt function. If an event has occurred since the last read of this register, the corresponding status bit will be set. The status indications in this register will be set even if the interrupt is not enabled.

Table 7-39. INTERRUPT_STATUS Register Field Descriptions

Bit	Field	Type	Reset	Description
15	AUTONEG_ERR	RC	0h	1 = Auto-Negotiation error has occurred 0 = Auto-Negotiation error has not occurred THIS BIT IS LH (Latched-High)
14	SPEED_CHNG	RC	0h	1 = Link speed has changed 0 = Link speed has not changed THIS BIT IS LH (Latched-High)
13	DUPLEX_MODE_CHNG	RC	0h	1 = Duplex mode has changed 0 = Duplex mode has not changed THIS BIT IS LH (Latched-High)
12	PAGE_RECEIVED	RC	0h	1 = Page has been received 0 = Page has not been received THIS BIT IS LH (Latched-High)
11	AUTONEG_COMP	RC	0h	1 = Auto-Negotiation has completed 0 = Auto-Negotiation has not completed THIS BIT IS LH (Latched-High)
10	LINK_STATUS_CHNG	RC	0h	1 = Link status has changed 0 = Link status has not changed THIS BIT IS LH (Latched-High)
9	EEE_ERR_STATUS	R	0h	1 = EEE error has been detected
8	FALSE_CARRIER	RC	0h	1 = Enable interrupt 0 = Disable interrupt THIS BIT IS LH (Latched-High)
7	ADC_FIFO_OVF_UNF	RC	0h	1 = Overflow / underflow has been detected in one of ADC's FIFOs THIS BIT IS LH (Latched-High)
6	MDI_CROSSOVER_CHNG	RC	0h	1 = MDI crossover has changed 0 = MDI crossover has not changed THIS BIT IS LH (Latched-High)
5	SPEED_OPT_EVENT	RC	0h	1 = MDI crossover has changed 0 = MDI crossover has not changed THIS BIT IS LH (Latched-High)
4	SLEEP_MODE_CHNG	RC	0h	1 = Sleep mode has changed 0 = Sleep mode has not changed THIS BIT IS LH (Latched-High)
3	WOL_STATUS	R	0h	1 = WoL (or pattern) packet has been received
2	XGMII_ERR_STATUS	R	0h	1 = Overflow / underflow has been detected in one of GMII / RGMII / SGMII buffers 0 = Overflow / underflow has not been detected
1	POLARITY_CHNG	R	0h	1 = Data polarity has changed 0 = Data polarity has not changed THIS BIT IS LH (Latched-High)
0	JABBER	RC	0h	1 = Jabber detected 0 = Jabber not detected THIS BIT IS LH (Latched-High)

7.6.1.19 GEN_CFG2 Register (Offset = 14h) [Reset = 29C7h]

GEN_CFG2 is shown in [Table 7-40](#).

Return to the [Summary Table](#).

Table 7-40. GEN_CFG2 Register Field Descriptions

Bit	Field	Type	Reset	Description
15	PD_DETECT_EN	R/WtoPH	0h	0h = Disable PD detection 1h = Enable PD (Powered Device) detection
14	SGMII_TX_ERR_DIS	R/W	0h	0h = Enable SGMII TX Error indication 1h = Disable SGMII TX Error indication
13	INTERRUPT_POLARITY	R/W	1h	0h = Interrupt pin is active high 1h = Interrupt pin is active low
12	SGMII_SOFT_RESET	R/WtoPH	0h	Setting this bit will generate a soft reset pulse of SGMII. This register is WSC (write-self-clear).
11-10	SPEED_OPT_ATTEMPT_CNT	R/W	2h	Selects the number of 1G link establishment attempt failures prior to performing Speed Optimization: 0h = 1 attempt 1h = 2 attempts 2h = 4 attempts 3h = 8 attempts

Table 7-40. GEN_CFG2 Register Field Descriptions (continued)

Bit	Field	Type	Reset	Description
9	SPEED_OPT_EN	R/W	0h	0h = Disable Speed Optimization 1h = Enable Speed Optimization
8	SPEED_OPT_ENHANCE_D_EN	R/W	1h	In enhanced mode, speed is optimized if energy is not detected in channels C and D 0h = Disable Speed Optimization enhanced mode 1h = Enable Speed Optimization enhanced mode
7	SGMII_AUTONEG_EN	R/W	1h	0h = Disable SGMII Auto-Negotiation 1h = Enable SGMII Auto-Negotiation
6	SPEED_OPT_10M_EN	R/W	1h	0h = Disable speed optimization to 10M 1h = Enable speed optimization to 10M (If link establishments of 1G and 100M fail)
5-4	MII_CLK_CFG	R/W	0h	Selects frequency of GMII_TX_CLK in 1G mode: 0h = 2.5Mhz 1h = 25Mhz 2h = Disabled 3h = Disabled
3	COL_FD_EN	R/W	0h	0h = Disable COL indication in full duplex mode 1h = Enable COL indication in full duplex mode
2	LEGACY_CODING_TXM_ODE_EN	R/W	1h	0h = Disable automatic selection of Legacy scrambler mode in 1G, Master mode 1h = Enable automatic selection of Legacy scrambler mode in 1G, Master mode
1	MASTER_SEMI_CROSS_EN	R/W	1h	0h = Disable semi-cross mode in 1G Master mode 1h = Enable semi-cross mode in 1G Master mode
0	SLAVE_SEMI_CROSS_EN	R/W	1h	0h = Disable semi-cross mode in 1G Slave mode 1h = Enable semi-cross mode in 1G Slave mode

7.6.1.20 RX_ERR_CNT Register (Offset = 15h) [Reset = 0000h]

RX_ERR_CNT is shown in [Table 7-41](#).

Return to the [Summary Table](#).

Table 7-41. RX_ERR_CNT Register Field Descriptions

Bit	Field	Type	Reset	Description
15-0	RX_ERROR_COUNT	R/W1C	0h	Receive Error Counter

7.6.1.21 BIST_CONTROL Register (Offset = 16h) [Reset = 0000h]

BIST_CONTROL is shown in [Table 7-42](#).

Return to the [Summary Table](#).

This register is used for Build-In Self Test (BIST) configuration. The BIST functionality provides Pseudo Random Bit Stream (PRBS) mechanism including packet generation generator and checker. Selection of the exact loopback point in the signal chain is also done in this register.

Table 7-42. BIST_CONTROL Register Field Descriptions

Bit	Field	Type	Reset	Description
15-12	PACKET_GEN_EN_3:0	R/W	0h	These bits along controls PRBS generator. Other values are not applicable. 0h = Disable PRBS Fh = Enable Continuous PRBS
11-10	RESERVED	R	0h	Reserved
9	RESERVED	R/W	0h	Reserved

Table 7-42. BIST_CONTROL Register Field Descriptions (continued)

Bit	Field	Type	Reset	Description
8	RESERVED	R/W	0h	Reserved
7	REV_LOOP_RX_DATA_CTRL	R/W	0h	Reverse Loopback Receive Data Control: This bit may only be set in Reverse Loopback mode 0h = Suppress RX packets to MAC in reverse loop 1h = Send RX packets to MAC in reverse loop
6	MII_LOOP_TX_DATA_CTRL	R/W	0h	MII Loopback Transmit Data Control: This bit may only be set in MII Loopback mode 0h = Suppress data to MDI in MII loop 1h = Transmit data to MDI in MII loop
5-2	LOOP_TX_DATA_MIX	R/W	0h	Loopback Mode Select: PCS loopback must be disabled (Bits[1:0] = 00) 0h = No Loopback 1h = Digital Loopback 2h = Analog Loopback 4h = External Loopback 8h = Reverse Loopback
1-0	LOOPBACK_MODE	R/W	0h	PCS loopback select – When configured in 1000Base-T, X1b : Loop before 1000Base-T signal processing When configured in 100Base-TX, 0h = See bits [5:2] 01b = Loop before scrambler 10b = Loop after scrambler, before MLT3 encoder 11b = Loop after MLT3 encoder (full TX/RX path)

7.6.1.22 GEN_STATUS2 Register (Offset = 17h) [Reset = 0040h]

GEN_STATUS2 is shown in [Table 7-43](#).

Return to the [Summary Table](#).

Table 7-43. GEN_STATUS2 Register Field Descriptions

Bit	Field	Type	Reset	Description
15	PD_PASS	RC	0h	1b = PD (Powered Device) has been successfully detected 0b = PD has not been detected
14	PD_PULSE_DET_ZERO	RC	0h	1b = PD detection mechanism has received no signal 0b = PD detection mechanism has received signal
13	PD_FAIL_WD	RC	0h	1b = PD detection mechanism watchdog has expired 0b = PD detection mechanism watchdog has not expired
12	PD_FAIL_NON_PD	RC	0h	1b = PD detection mechanism has detected a non-powered device 0b = PD detection mechanism has not detected a non-powered device
11	PRBS_LOCK	R	0h	1b = PRBS checker is locked sync) on received byte stream 0b = PRBS checker is not locked
10	PRBS_SYNC_LOSS	R	0h	1b = PRBS checker has lost sync 0b = PRBS checker has not lost sync LH - clear on read register
9	PKT_GEN_BUSY	R	0h	1b = Packet generator is in process 0b = Packet generator is not in process
8	SCR_MODE_MASTER_1G	R	0h	1b = 1G PCS (master) is in legacy encoding mode 0b = 1G PCS (master) is in normal encoding mode
7	SCR_MODE_SLAVE_1G	R	0h	1b = 1G PCS (slave) is in legacy encoding mode 0b = 1G PCS (slave) is in normal encoding mode
6	CORE_PWR_MODE	R	1h	1b = Core is in normal power mode 0b = Core is powered down or in sleep mode
5-0	RESERVED	R	0h	Reserved

7.6.1.23 LEDS_CFG1 Register (Offset = 18h) [Reset = 6XXXh]

LEDS_CFG1 is shown in [Table 7-44](#).

Return to the [Summary Table](#).

Table 7-44. LEDS_CFG1 Register Field Descriptions

Bit	Field	Type	Reset	Description
15-12	LED_GPIO_SEL	R/W	6h	Source of GPIO LED, same as bits 3:0
11-8	LED_2_SEL	R/W	X	See Strap Configuration section for defaults. Source of LED_2 (LED 2) , same as bits 3:0
7-4	LED_1_SEL	R/W	X	See Strap Configuration section for defaults. Source of LED_1 (LED 1) , same as bits 3:0
3-0	LED_0_SEL	R/W	X	See Strap Configuration section for defaults. Source of LED_0 (LED 0) 0h = link OK 1h = RX/TX activity 2h = TX activity 3h = RX activity 4h = collision detected 5h = 1000BT link is up 6h = 100 BTX link is up 7h = 10BT link is up 8h = 10/100BT link is up 9h = 100/1000BT link is up Ah = full duplex Bh = link OK (copper only) + blink on TX/RX activity Ch = NA Dh = RX_ER or TX_ER Eh = RX_ER

7.6.1.24 LEDS_CFG2 Register (Offset = 19h) [Reset = 4444h]

LEDS_CFG2 is shown in [Table 7-45](#).

Return to the [Summary Table](#).

Table 7-45. LEDS_CFG2 Register Field Descriptions

Bit	Field	Type	Reset	Description
15	RESERVED	R	0h	Reserved
14	LED_GPIO_POLARITY	R/W	1h	GPIO LED polarity: Default depends on strap, non strap default Active High 0h = Active low 1h = Active high
13	LED_GPIO_DRV_VAL	R/W	0h	If bit #12 is set, this is the value of GPIO LED
12	LED_GPIO_DRV_EN	R/W	0h	Force value to LED_GPIO as per bit #13 0h = LED_GPIO is in normal operation mode 1h = Force the value of LED_GPIO
11	RESERVED	R	0h	Reserved
10	LED_2_POLARITY	R/W	1h	LED_2 polarity. Default depends on strap, non strap default Active High 0h = Active low 1h = Active high
9	LED_2_DRV_VAL	R/W	0h	If bit #8 is set, this is the value of LED_2
8	LED_2_DRV_EN	R/W	0h	Force value to LED_GPIO as per bit #9 0h = LED_2 is in normal operation mode 1h = Drive the value of LED_2
7	RESERVED	R	0h	Reserved

Table 7-45. LEDS_CFG2 Register Field Descriptions (continued)

Bit	Field	Type	Reset	Description
6	LED_1_POLARITY	R/W	1h	LED_1 polarity: Default depends on strap, non strap default Active High 0h = Active low 1h = Active high
5	LED_1_DRV_VAL	R/W	0h	If bit #4 is set, this is the value of LED_1
4	LED_1_DRV_EN	R/W	0h	Force value to LED_GPIO as per bit #5 0h = LED_1 is in normal operation mode 1h = Drive the value of LED_1
3	RESERVED	R	0h	Reserved
2	LED_0_POLARITY	R/W	1h	LED_0 polarity: Default depends on strap, non strap default Active High 0h = Active low 1h = Active high
1	LED_0_DRV_VAL	R/W	0h	If bit #1 is set, this is the value of LED_0
0	LED_0_DRV_EN	R/W	0h	Force value to LED_GPIO as per bit #1 0h = LED_0 is in normal operation mode 1h = Drive the value of LED_0

7.6.1.25 LEDS_CFG3 Register (Offset = 1Ah) [Reset = 0002h]LEDS_CFG3 is shown in [Table 7-46](#).Return to the [Summary Table](#).**Table 7-46. LEDS_CFG3 Register Field Descriptions**

Bit	Field	Type	Reset	Description
15-3	RESERVED	R	0h	Reserved
2	LEDS_BYPASS_STRETCHING	R/W	0h	0b = Normal Operation 1b = Bypass LEDs stretching
1-0	LEDS_BLINK_RATE	R/W	2h	00b = 20Hz (50mSec) 01b = 10Hz (100mSec) 10b = 5Hz (200mSec) 11b = 2Hz (500mSec)

7.6.1.26 GEN_CFG4 Register (Offset = 1Eh) [Reset = 0012h]GEN_CFG4 is shown in [Table 7-47](#).Return to the [Summary Table](#).**Table 7-47. GEN_CFG4 Register Field Descriptions**

Bit	Field	Type	Reset	Description
15	RESERVED	R/W	0h	Reserved
14	CFG_FAST_ANEG_EN	R/W	0h	Enable Fast ANEG mode
13-12	CFG_FAST_ANEG_SEL_VAL	R/W	0h	when Fast ANEG mode enabled, value will select short timer duration 0x0 will be the shortest timers config and 0x2 the longest
11	CFG_ANEG_ADV_FD_EN	R/W	0h	this bit enables to declare FD also in parallel detect link, the IEEE defien on parallel detect to always declare HD, this bit allows also to declare FD in this scenario
10	RESTART_STATUS_BITS_EN	R/W	0h	reset enable 1b = clear all the phy status bits (part of register 0x11) 0b = do not clear the status bit
9	CFG_ROBUST_AMDIX_EN	R/W	0h	Enable Robust Auto MDI/MDIX resolution
8	CFG_FAST_AMDIX_EN	R/W	0h	Enable Fast Auto MDI-X mode
7	INT_OE	R/W	0h	Interrupt Output Enable: 1b = INTN/PWDNN Pad is an Interrupt Output 0b = INTN/PWDNN Pad in an Power Down Input

Table 7-47. GEN_CFG4 Register Field Descriptions (continued)

Bit	Field	Type	Reset	Description
6	FORCE_INTERRUPT	R/W	0h	1b = Assert interrupt pin 0b = Normal interrupt mode
5	RESERVED	R/W	0h	Reserved
4	RESERVED	R/W	0h	Reserved
3	FORCE_1G_AUTONEG_EN	R/W	0h	1b = Invoke Auto-Negotiation with only 1G advertised when manual speed in register 0x0000 is 1G 0b = Do not invoke Auto-Negotiation when manual speed in register 0x0000 is 1G
2	TDR_FAIL	R	0h	
1	TDR_DONE	R	1h	
0	TDR_START	R/WtoPH	0h	1b = Start TDR 0b = TDR Completed

7.6.1.27 GEN_CTRL Register (Offset = 1Fh) [Reset = 0000h]

GEN_CTRL is shown in [Table 7-48](#).

Return to the [Summary Table](#).

Table 7-48. GEN_CTRL Register Field Descriptions

Bit	Field	Type	Reset	Description
15	SW_RESET	R/WtoPH	0h	Software Reset This will reset the PHY and return registers to their default values. Registers controlled via strap pins will return back to their last strapped values. 0h = Normal mode 1h = Reset PHY
14	SW_RESTART	R/WtoPH	0h	Soft Restart Restarts the PHY without affecting registers. 0h = Normal Operation 1h = Software Reset
13	RESERVED	R/W	0h	Reserved
12-7	RESERVED	R/W	0h	Reserved
6-0	RESERVED	R/W	0h	Reserved

7.6.1.28 ANALOG_TEST_CTRL Register (Offset = 25h) [Reset = 0480h]

ANALOG_TEST_CTRL is shown in [Table 7-49](#).

Return to the [Summary Table](#).

Table 7-49. ANALOG_TEST_CTRL Register Field Descriptions

Bit	Field	Type	Reset	Description
15-12	RESERVED	R	0h	Reserved
11-10	TM7_PULSE_SEL	R/W	1h	Selects pulse amplitude and polarity for Test Mode 7 (See register 0x9): 00b = +2 01b = -2 10b = +1 11b = -1
9	EXTND_TM7_100BT_MSB	R/W	0h	MSB of configurable length for 100BT extended TM7 For 100BT Test Mode: repetitive sequence of "1" with configurable number of "0". Bits { 9,[3:0] } define the number of "0" to follow the "1", from 1 to 31. 0,0001 - 1,1111 : single "0" to 31 zeros. 0,0000 - clear the shiftreg.
8	EXTND_TM7_100BT_EN	R/W	0h	Enable extended TM7 for 100M. NOTE1: bit 4 must be "0" for 100BT TestMode. NOTE2: 100BT testmode must be Clear before applying new Value. e.g, one need to write 0x0 before configuring new value. NOTE3: use FORCE100 for 100BT testing, via Reg0x0.
7-5	STIM_CH_SEL	R/W	4h	Selects the channel(s) that outputs the test mode: If bit #7 is set, test mode is driven to all channels. If bit #7 is cleared, test mode is driven according to bits 6:5 - 00b = Channel A 01b = Channel B 10b = Channel C 11b = Channel D

Table 7-49. ANALOG_TEST_CTRL Register Field Descriptions (continued)

Bit	Field	Type	Reset	Description
4-0	ANALOG_TEST	R/W	0h	Bit [4] enables 10BaseT test modes. Bits [3:0] select the 10BaseT test pattern, as follows: To operate extended TM7 for 100BT, bits 3:0 shall be configured as well - more details in bit #9 0000b = Single NLP 0001b = Single Pulse 1 0010b = Single Pulse 0 0011b = Repetitive 1 0100b = Repetitive 0 0101b = Preamble (repetitive "10") 0110b = Single 1 followed by TP_IDLE 0111b = Single 0 followed by TP_IDLE 1000b = Repetitive "1001" sequence 1001b = Random 10Base-T data 1010b = TP_IDLE_00 1011b = TP_IDLE_01 1100b = TP_IDLE_10 1101b = TP_IDLE_11 0110b = Proprietary T.M for amplitude, RFT, DCD and template for FT on tester (1000) ----> need to write register 0 0x2000

7.6.1.29 GEN_CFG_ENH_AMIX Register (Offset = 2Ch) [Reset = 141Fh]

GEN_CFG_ENH_AMIX is shown in [Table 7-50](#).

Return to the [Summary Table](#).

Table 7-50. GEN_CFG_ENH_AMIX Register Field Descriptions

Bit	Field	Type	Reset	Description
15-14	RESERVED	R	0h	Reserved
13-9	CFG_FLD_WINDOW_CNT	R/W	Ah	counter to define the window in which we look for fast link down criteria, default 10usec
8-4	CFG_FAST_AMDIX_VAL	R/W	1h	timer of the mdi/x switch counter in force 100m fast amdix mode, very fast as it need only to allow far end to detect energy ~4ms in default
3-0	CFG_ROBUST_AMDIX_VAL	R/W	Fh	the value of the timer that switch mdi/x in robust mode, this should be long timer to allow far end to still do parallel detect with the IEEE ANEG timers... default ~0.5s

7.6.1.30 GEN_CFG_FLD Register (Offset = 2Dh) [Reset = 0000h]

GEN_CFG_FLD is shown in [Table 7-51](#).

Return to the [Summary Table](#).

Table 7-51. GEN_CFG_FLD Register Field Descriptions

Bit	Field	Type	Reset	Description
15	CFG_FORCE_DROP_LINK_EN	R/W	0h	Drop link (stop transmitting) when no signal is received
14	FLD_BYPASS_MAX_WAIT_TIMER	R/W	0h	If set, MAX_WAIT_TIMER is skipped (and therefore link is dropped faster)
13	SLICER_OUT_STUCK	R	0h	indicate slicer)out_stuck status
12-8	FLD_STATUS	R	0h	Fast link down status LH - clear on read register
7-5	RESERVED	R	0h	Reserved
4-0	CFG_FAST_LINK_DOWN_MODES	R/W	0h	5 bits for different fast link down option (can all work simultaneously): bit [0] - energy lost bit [1] - mse bit [2] - ml3 errors bit [3] - rx_err bit [4] - descrambler sync loss

7.6.1.31 GEN_CFG_FLD_THR Register (Offset = 2Eh) [Reset = 0221h]

GEN_CFG_FLD_THR is shown in [Table 7-52](#).

Return to the [Summary Table](#).

Table 7-52. GEN_CFG_FLD_THR Register Field Descriptions

Bit	Field	Type	Reset	Description
15-11	RESERVED	R	0h	Reserved
10-8	ENERGY_WINDOW_LEN_FLD	R/W	2h	window length in FLD energy lost mode for energy detection accumulator
7	RESERVED	R	0h	Reserved
6-4	ENERGY_ON_FLD_THR	R/W	2h	energy lost threshold for FLD energy lost mode. energy_detected indication will be asserted when energy detector accumulator exceeds this threshold.
3	RESERVED	R	0h	Reserved
2-0	ENERGY_LOST_FLD_THR	R/W	1h	energy lost threshold for FLD energy lost mode energy_lost indication will be asserted if energy detector accumulator falls below this threshold.

7.6.1.32 GEN_CFG3 Register (Offset = 31h) [Reset = 10B0h]

GEN_CFG3 is shown in [Table 7-53](#).

Return to the [Summary Table](#).

Table 7-53. GEN_CFG3 Register Field Descriptions

Bit	Field	Type	Reset	Description
15	RESERVED	R	0h	Reserved
14	RESERVED	R/W	0h	Reserved
13	RESERVED	R/W	0h	Reserved
12	RESERVED	R/W	0h	Reserved
11-9	RESERVED	R	0h	Reserved
8	RESERVED	R/W	0h	Reserved
7	RESERVED	R/W	0h	Reserved
6-5	SGMII_AUTONEG_TIMER	R/W	1h	Selects duration of SGMII Auto-Negotiation timer: 00: 1.6ms 01: 2µs 10: 800µs 11: 11ms
4	RESERVED	R/W	0h	Reserved
3	RESERVED	R/W	0h	Reserved
2	RESERVED	R/W	0h	Reserved
1	RESERVED	R	0h	Reserved
0	PORT_MIRRORING_MODE	R/W	0h	Port mirroring mode: 0 - Disabled 1 - Enabled

7.6.1.33 RGMII_CTRL Register (Offset = 32h) [Reset = 00D0h]

RGMII_CTRL is shown in [Table 7-54](#).

Return to the [Summary Table](#).

Table 7-54. RGMII_CTRL Register Field Descriptions

Bit	Field	Type	Reset	Description
15	RESERVED	R	0h	Reserved
14	RESERVED	R	0h	Reserved
13	RESERVED	R	0h	Reserved
12	RESERVED	R	0h	Reserved
11	RESERVED	R/W	0h	Reserved
10	RESERVED	R	0h	Reserved

Table 7-54. RGMII_CTRL Register Field Descriptions (continued)

Bit	Field	Type	Reset	Description
9	RESERVED	R/W	0h	Reserved
8	RESERVED	R/W	0h	Reserved
7	RESERVED	R/W	0h	Reserved
6-5	RGMII_RX_HALF_FULL_THR	R/W	2h	RGMII RX sync FIFO Half-full Threshold Bits 1:0 of the 3-bit threshold field. Bit2 can be found in Reg 0x33[1]. The default setting 2 will start a FIFO read when the difference between the write and read pointer is 4. The TX/RX FIFOs have a depth of 8. Increasing the threshold from 2 to 3 will increase the latency by 1 read cycle; while decreasing the threshold from 2 to 1 will decrease latency by 1 read cycle. If the difference between ppm of the read and write clocks is significant, a half-full threshold can cause either FIFO underflow or overflow.
4-3	RGMII_TX_HALF_FULL_THR	R/W	2h	RGMII TX sync FIFO Half-full Thresholds Bits 1:0 of the 3-bit threshold field. Bit2 can be found in Reg 0x33[0] See RGMII_RX_HALF_FULL_THR for more details.
2	SUPPRESS_TX_ERR_EN	R/W	0h	
1	RGMII_TX_CLK_DELAY	R/W	0h	RGMII Transmit Clock Delay 0h = RGMII transmit clock is shifted with respect to transmit data. 1h = RGMII transmit clock is aligned with respect to transmit data.
0	RGMII_RX_CLK_DELAY	R/W	0h	RGMII Receive Clock Delay 0h = RGMII receive clock is shifted with respect to receive data. 1h = RGMII transmit clock is aligned with respect to receive data.

7.6.1.34 RGMII_CTRL2 Register (Offset = 33h) [Reset = 0000h]

RGMII_CTRL2 is shown in [Table 7-55](#).

Return to the [Summary Table](#).

Table 7-55. RGMII_CTRL2 Register Field Descriptions

Bit	Field	Type	Reset	Description
15-5	RESERVED	R	0h	Reserved
4	RGMII_AF_BYPASS_EN	R/W	0h	RGMII Async FIFO Bypass Enable: 1 = Enable RGMII Async FIFO Bypass. 0 = Normal operation.
3	RGMII_AF_BYPASS_DLY_EN	R/W	0h	RGMII Async FIFO Bypass Delay Enable: 1 = Delay RX_CLK when operating in 10/100 with RGMII. 0 = Normal operation
2	LOW_LATENCY_10_100_EN	R/W	0h	Low Latency 10/100 Enable: 1 = Enable low latency in 10/100 operation. 0 = Normal operation.
1	RGMII_RX_HALF_FULL_THR_MSB	R/W	0h	RGMII RX sync FIFO Half-full Threshold Bit2 of the 3-bit threshold field. Bits 1:0 can be found in Reg 0x32[6:5], respectively.
0	RGMII_TX_HALF_FULL_THR_MSB	R/W	0h	RGMII TX sync FIFO Half-full Threshold Bit2 of the 3-bit threshold field. Bits 1:0 can be found in Reg 0x32[4:3], respectively.

7.6.1.35 SGMII_AUTO_NEG_STATUS Register (Offset = 37h) [Reset = 0000h]

SGMII_AUTO_NEG_STATUS is shown in [Table 7-56](#).

Return to the [Summary Table](#).

Table 7-56. SGMII_AUTO_NEG_STATUS Register Field Descriptions

Bit	Field	Type	Reset	Description
15-2	RESERVED	R	0h	Reserved
1	SGMII_PAGE_RX	R	0h	1b = indicate that a new auto-neg page was received

Table 7-56. SGMII_AUTO_NEG_STATUS Register Field Descriptions (continued)

Bit	Field	Type	Reset	Description
0	SGMII_AUTONEG_COMPLETE	R	0h	1b = Auto-Negotiation process completed 0b = Auto-Negotiation process not completed

7.6.1.36 PRBS_TX_CHK_CTRL Register (Offset = 39h) [Reset = 0000h]

PRBS_TX_CHK_CTRL is shown in [Table 7-57](#).

Return to the [Summary Table](#).

Table 7-57. PRBS_TX_CHK_CTRL Register Field Descriptions

Bit	Field	Type	Reset	Description
15	RESERVED	R	0h	Reserved
14-7	PRBS_TX_CHK_ERR_CNT	R	0h	Holds number of errored bytes that received by the PRBS TX checker. When TX PRBS Count Mode (see bit [1]) set to 0, count stops on 0xFF. Notes: Writing bit 7 generates a lock signal for the PRBS TX counters. Writing bit 8 generates a lock and clear signal for the PRBS TX counters
6	RESERVED	R	0h	Reserved
5	PRBS_TX_CHK_SYNC_LOSS	R	0h	1b = PRBS TX checker has lost sync 0b = PRBS TX checker has not lost sync This bit is LH
4	PRBS_TX_CHK_LOCK_STATUS	R	0h	1b = PRBS TX checker is locked on received byte stream 0b = PRBS TX checker is not locked
3	RESERVED	R	0h	Reserved
2	PRBS_TX_CHK_BYTE_COUNTER_OVF	R	0h	If set, bytes counter reached overflow
1	PRBS_TX_CHK_CNT_MODE	R/W	0h	PRBS Checker Mode 1b = Continuous mode 0b = Single Mode.
0	PRBS_TX_CHK_EN	R/W	0h	If set, PRBS TX checker is enabled (PRBS TX checker is used in external reverse loop)

7.6.1.37 PRBS_TX_CHK_BYTE_CNT Register (Offset = 3Ah) [Reset = 0000h]

PRBS_TX_CHK_BYTE_CNT is shown in [Table 7-58](#).

Return to the [Summary Table](#).

Table 7-58. PRBS_TX_CHK_BYTE_CNT Register Field Descriptions

Bit	Field	Type	Reset	Description
15-0	PRBS_TX_CHK_BYTE_COUNTER	R	0h	Holds number of total bytes that received by the PRBS TX checker. Value in this register is locked when write is done to register PRBS_TX_CHK_CTRL bit[7]or bit[8]. When PRBS Count Mode set to zero, count stops on 0xFFFF (see register 0x0016)

7.6.1.38 G_100BT_REG0 Register (Offset = 43h) [Reset = 07A0h]

G_100BT_REG0 is shown in [Table 7-59](#).

Return to the [Summary Table](#).

Table 7-59. G_100BT_REG0 Register Field Descriptions

Bit	Field	Type	Reset	Description
15-12	RESERVED	R	0h	Reserved
11	RESERVED	R/W	0h	Reserved
10-7	RESERVED	R/W	0h	Reserved

Table 7-59. G_100BT_REG0 Register Field Descriptions (continued)

Bit	Field	Type	Reset	Description
6	RESERVED	R/W	0h	Reserved
5	RESERVED	R/W	0h	Reserved
4	RESERVED	R/W	0h	Reserved
3	RESERVED	R/W	0h	Reserved
2	RESERVED	R/W	0h	Reserved
1	RESERVED	R/W	0h	Reserved
0	FAST_RX_DV	R/W	0h	Enable Fast RX_DV for low latency in 100Mbps mode. 0h = Fast rx dv disable 1h = Fast rx dv enable

7.6.1.39 SERDES_SYNC_STS Register (Offset = 4Fh) [Reset = 0000h]

SERDES_SYNC_STS is shown in [Table 7-60](#).

Return to the [Summary Table](#).

Table 7-60. SERDES_SYNC_STS Register Field Descriptions

Bit	Field	Type	Reset	Description
15-12	RESERVED	R/W	0h	Reserved
11	RESERVED	R/W	0h	Reserved
10	RESERVED	R	0h	Reserved
9	RESERVED	R	0h	Reserved
8	SYNC_STATUS	R	0h	Synchronization Status 0h = No Sync 1h = Sync Established
7-4	RESERVED	R	0h	Reserved
3-0	RESERVED	R	0h	Reserved

7.6.1.40 G_1000BT_PMA_STATUS Register (Offset = 55h) [Reset = 0000h]

G_1000BT_PMA_STATUS is shown in [Table 7-61](#).

Return to the [Summary Table](#).

Table 7-61. G_1000BT_PMA_STATUS Register Field Descriptions

Bit	Field	Type	Reset	Description
15-8	RESERVED	R	0h	Reserved
7-4	PMA_MASTER_FIFO_CTL RL	R	0h	1000Mb SFD Variation in Master Mode
3-0	PMA_SLAVE_FIFO_CTRL	R	0h	1000Mb SFD Variation in Slave Mode

7.6.1.41 STRAP_STS Register (Offset = 6Eh) [Reset = 0000h]

STRAP_STS is shown in [Table 7-62](#).

Return to the [Summary Table](#).

Table 7-62. STRAP_STS Register Field Descriptions

Bit	Field	Type	Reset	Description
15-14	RESERVED	R	0h	Reserved

Table 7-62. STRAP_STS Register Field Descriptions (continued)

Bit	Field	Type	Reset	Description
13	STRAP_LINK_LOSS_PAS S_THRU	R	0h	Link Loss Pass Through Enable Strap 0h = Enable 1h = Disable
12	STRAP_MIRROR_EN	R	0h	Mirror Mode Enable Strap. Refer to strap configuration section as this strap also decides MAC interface in Bridge Mode applications. 0h = Disable 1h = Enable
11-9	STRAP_OPMODE	R	0h	OPMODE Strap 0h = RGMII To Copper 1h = RGMII to 1000Base-X 2h = RGMII to 100Base-FX 3h = RGMII-SGMII Bridge 4h = 1000Base-T to 1000Base-X 5h = 100Base-T to 100Base-FX 6h = SGMII to Copper 7h = JTAG for Boundary Scan
8-4	STRAP_PHY_ADD	R	0h	PHY Address Strap
3-2	STRAP_ANEGSEL	R	0h	Auto Negotiation Mode Select Strap. Refer to Strap Configuration Section
1	STRAP_ANEG_EN	R	0h	Auto Negotiation Enable Strap 0h = Enable 1h = Disable
0	RESERVED	R	0h	Reserved

7.6.1.42 DBG_PRBS_BYTE_CNT Register (Offset = 71h) [Reset = 0000h]

DBG_PRBS_BYTE_CNT is shown in [Table 7-63](#).

Return to the [Summary Table](#).

Table 7-63. DBG_PRBS_BYTE_CNT Register Field Descriptions

Bit	Field	Type	Reset	Description
15-0	PRBS_BYTE_CNT	R	0h	Holds number of total bytes that received by the PRBS checker. Value in this register is locked when write is done to register DBG_PRBS_ERR_CNT bit[0] or bit[1]. When PRBS Count Mode set to zero, count stops on 0xFFFF (see register 0x0016)

7.6.1.43 DBG_PRBS_ERR_CNT Register (Offset = 72h) [Reset = 0000h]

DBG_PRBS_ERR_CNT is shown in [Table 7-64](#).

Return to the [Summary Table](#).

Table 7-64. DBG_PRBS_ERR_CNT Register Field Descriptions

Bit	Field	Type	Reset	Description
15-11	RESERVED	R	0h	Reserved
10	PRBS_PKT_CNT_OVF	R	0h	If set, packet counter reached overflow Overflow is cleared when PRBS counters are cleared - done by setting bit #1 of this register
9	PRBS_BYTE_CNT_OVF	R	0h	If set, bytes counter reached overflow Overflow is cleared when PRBS counters are cleared - done by setting bit #1 of this register
8	RESERVED	R	0h	Reserved

Table 7-64. DBG_PRBS_ERR_CNT Register Field Descriptions (continued)

Bit	Field	Type	Reset	Description
7-0	PRBS_ERR_CNT	R	0h	Holds number of errored bytes that received by the PRBS checker. Value in this register is locked when write is done to bit[0] or bit[1] (see below). When PRBS Count Mode set to zero, count stops on 0xFF (see register 0x0016) Notes: Writing bit 0 generates a lock signal for the PRBS counters. Writing bit 1 generates a lock and clear signal for the PRBS counters

7.6.1.44 DBG_PKT_LEN_PRBS Register (Offset = 7Bh) [Reset = 05DCh]

DBG_PKT_LEN_PRBS is shown in [Table 7-65](#).

Return to the [Summary Table](#).

Table 7-65. DBG_PKT_LEN_PRBS Register Field Descriptions

Bit	Field	Type	Reset	Description
15-0	PKT_LEN_PRBS	R/W	5DCh	Length (in bytes) of PRBS packets, this effect the PRBS packets and not

7.6.1.45 DBG_IPG_LEN Register (Offset = 7Ch) [Reset = 007Dh]

DBG_IPG_LEN is shown in [Table 7-66](#).

Return to the [Summary Table](#).

Table 7-66. DBG_IPG_LEN Register Field Descriptions

Bit	Field	Type	Reset	Description
15-8	RESERVED	R	0h	Reserved
7-0	IPG_LEN	R/W	7Dh	Inter-packet gap (in 4 bytes) between PRBS packets. IPG increments in steps of 4 bytes

7.6.1.46 ANA_RGMII_DLL_CTRL Register (Offset = 86h) [Reset = 0077h]

ANA_RGMII_DLL_CTRL is shown in [Table 7-67](#).

Return to the [Summary Table](#).

Table 7-67. ANA_RGMII_DLL_CTRL Register Field Descriptions

Bit	Field	Type	Reset	Description
15-10	RESERVED	R	0h	Reserved
9	DLL_EN_FORCE_VAL	R/W	0h	If dll_en_force_en is set, this is the value of DLL_EN
8	DLL_EN_FORCE_CTRL	R/W	0h	Force DLL_EN value
7-4	DLL_TX_DELAY_CTRL_SL	R/W	7h	Steps of 250ps, affects the CLK_90 output. - same behavior as bit [3:0]
3-0	DLL_RX_DELAY_CTRL_SL	R/W	7h	Steps of 250ps, affects the CLK_90 output. b[3], b[2], b[1], b[0], shift, mode please note - the actual delay is also effected by the shift mode in reg 0x32 3h = 1.0ns, Shift 5h = 1.5ns, Shift 7h = 2.0 ns, Shift(*) - default 9h = 2.5ns, Shift Bh = 3.0 ns, Shift Dh = 3.5ns, Shift Fh = 0ns, Align(**)

7.6.1.47 ANA_PLL_PROG_PI Register (Offset = C6h) [Reset = 0000h]

ANA_PLL_PROG_PI is shown in [Table 7-68](#).

Return to the [Summary Table](#).

Table 7-68. ANA_PLL_PROG_PI Register Field Descriptions

Bit	Field	Type	Reset	Description
15-0	RESERVED	R/W	0h	Reserved

7.6.1.48 SGMII_TESTMODE Register (Offset = D6h) [Reset = 0000h]

SGMII_TESTMODE is shown in [Table 7-69](#).

Return to the [Summary Table](#).

Table 7-69. SGMII_TESTMODE Register Field Descriptions

Bit	Field	Type	Reset	Description
15	RESERVED	R/W	0h	Reserved
14-13	SGMII_TESTMODE_SWING	R/W	0h	Voltage Swing Pk-Pk Typ (V) 0h = 1.100 (default) 1h = 1.280 2h = 0.920 3h = Do not use
12-0	RESERVED	R/W	0h	Reserved

7.6.1.49 DSP_HYBRID_CFG2 Register (Offset = E9h) [Reset = 9F22h]

DSP_HYBRID_CFG2 is shown in [Table 7-70](#).

Return to the [Summary Table](#).

Table 7-70. DSP_HYBRID_CFG2 Register Field Descriptions

Bit	Field	Type	Reset	Description
15	RESERVED	R/W	0h	Reserved
14	RESERVED	R/W	0h	Reserved
13	RESERVED	R/W	0h	Reserved
12-8	RESERVED	R/W	0h	Reserved
7-5	RESERVED	R/W	0h	Reserved
4-0	RESERVED	R/W	0h	Reserved

7.6.1.50 LOOPCR Register (Offset = FEh) [Reset = E720h]

LOOPCR is shown in [Table 7-71](#).

Return to the [Summary Table](#).

Table 7-71. LOOPCR Register Field Descriptions

Bit	Field	Type	Reset	Description
15-13	FB_AEQ_CNT	R/W	7h	AEQ max number of fallbacks
12-8	AEQ_MAX_STEP	R/W	7h	the max step in aeq table
7-5	AEQ_STEP_SIZE	R/W	1h	increment step for aeq table
4-1	RESERVED	R	0h	

Table 7-71. LOOPCR Register Field Descriptions (continued)

Bit	Field	Type	Reset	Description
0	AEQ_BEG	R/W	0h	starting index for aeq table 0h = normal operation 1h = near-end loopback

7.6.1.51 RXF_CFG Register (Offset = 134h) [Reset = 1000h]

RXF_CFG is shown in [Table 7-72](#).

Return to the [Summary Table](#).

Table 7-72. RXF_CFG Register Field Descriptions

Bit	Field	Type	Reset	Description
15-14	RESERVED	R/W	0h	Reserved
13	RESERVED	R/W	0h	Reserved
12	RESERVED	R/W	0h	Reserved
11	WOL_OUT_CLEAN	RH/WoP	0h	If WOL out is in level mode in bit 8, writing to this bit will clear it.
10-9	WOL_OUT_STRETCH	R/W	0h	If WOL out is in pulse mode in bit 8, this is the pulse length: 0h = 8 clock cycles 1h = 16 clock cycles 2h = 32 clock cycles 3h = 64 clock cycles
8	WOL_OUT_MODE	R/W	0h	Mode of the wake up that goes to GPIO pin: 0h = Pulse Mode. 1h = Level Mode
7	ENHANCED_MAC_SUPPORT	R/W	0h	Enables enhanced RX features. This bit should be set when using wakeup abilities, CRC check or RX 1588 indication
6	RESERVED	R/W	0h	Reserved
5	RESERVED	R/W	0h	Reserved
4	WAKE_ON_UCAST	R/W	0h	If set, issue an interrupt upon reception of unicast packets
3	RESERVED	R/W	0h	Reserved
2	WAKE_ON_BCAST	R/W	0h	If set, issue an interrupt upon reception of broadcast packets
1	WAKE_ON_PATTERN	R/W	0h	If set, issue an interrupt upon reception of a packet with configured pattern
0	WAKE_ON_MAGIC	R/W	0h	If set, issue an interrupt upon reception of magic packet

7.6.1.52 RXF_STATUS Register (Offset = 135h) [Reset = 0000h]

RXF_STATUS is shown in [Table 7-73](#).

Return to the [Summary Table](#).

Table 7-73. RXF_STATUS Register Field Descriptions

Bit	Field	Type	Reset	Description
15-8	RESERVED	R	0h	Reserved
7	SFD_ERR	RC	0h	SFD Error Detected
6	BAD_CRC	RC	0h	Bad CRC Packet Received
5	RESERVED	RC	0h	Reserved
4	UCAST_RCVD	RC	0h	Unicast Packet Received
3	RESERVED	RC	0h	Reserved
2	BCAST_RCVD	RC	0h	Broadcast Packet Received
1	PATTERN_RCVD	RC	0h	Pattern Match Packet Received

Table 7-73. RXF_STATUS Register Field Descriptions (continued)

Bit	Field	Type	Reset	Description
0	MAGIC_RCVD	RC	0h	Magic Packet Received

7.6.1.53 RXF_PMATCH_DATA1 Register (Offset = 136h) [Reset = 0000h]

RXF_PMATCH_DATA1 is shown in [Table 7-74](#).

Return to the [Summary Table](#).

Table 7-74. RXF_PMATCH_DATA1 Register Field Descriptions

Bit	Field	Type	Reset	Description
15-0	PMATCH_DATA_15_0	R/W	0h	Bits 15:0 of Perfect Match Data - used for DA (destination address) match

7.6.1.54 RXF_PMATCH_DATA2 Register (Offset = 137h) [Reset = 0000h]

RXF_PMATCH_DATA2 is shown in [Table 7-75](#).

Return to the [Summary Table](#).

Table 7-75. RXF_PMATCH_DATA2 Register Field Descriptions

Bit	Field	Type	Reset	Description
15-0	PMATCH_DATA_31_16	R/W	0h	Bits 31:16 of Perfect Match Data - used for DA (destination address) match

7.6.1.55 RXF_PMATCH_DATA3 Register (Offset = 138h) [Reset = 0000h]

RXF_PMATCH_DATA3 is shown in [Table 7-76](#).

Return to the [Summary Table](#).

Table 7-76. RXF_PMATCH_DATA3 Register Field Descriptions

Bit	Field	Type	Reset	Description
15-0	PMATCH_DATA_47_32	R/W	0h	Bits 47:32 of Perfect Match Data - used for DA (destination address) match

7.6.1.56 RXF_SCRON_PASS1 Register (Offset = 139h) [Reset = 0000h]

RXF_SCRON_PASS1 is shown in [Table 7-77](#).

Return to the [Summary Table](#).

Table 7-77. RXF_SCRON_PASS1 Register Field Descriptions

Bit	Field	Type	Reset	Description
15-0	SCRON_PASSWORD_15_0	R/W	0h	Bits 15:0 of secure-on password (related to magic packet)

7.6.1.57 RXF_SCRON_PASS2 Register (Offset = 13Ah) [Reset = 0000h]

RXF_SCRON_PASS2 is shown in [Table 7-78](#).

Return to the [Summary Table](#).

Table 7-78. RXF_SCRON_PASS2 Register Field Descriptions

Bit	Field	Type	Reset	Description
15-0	SCRON_PASSWORD_31_16	R/W	0h	Bits 31:16 of secure-on password (related to magic packet)

7.6.1.58 RXF_SCRON_PASS3 Register (Offset = 13Bh) [Reset = 0000h]

RXF_SCRON_PASS3 is shown in [Table 7-79](#).

Return to the [Summary Table](#).

Table 7-79. RXF_SCRON_PASS3 Register Field Descriptions

Bit	Field	Type	Reset	Description
15-0	SCRON_PASSWORD_47_32	R/W	0h	Bits 47:32 of secure-on password (related to magic packet)

7.6.1.59 RXF_PATTERN_1 Register (Offset = 13Ch) [Reset = 0000h]

RXF_PATTERN_1 is shown in [Table 7-80](#).

Return to the [Summary Table](#).

Table 7-80. RXF_PATTERN_1 Register Field Descriptions

Bit	Field	Type	Reset	Description
15-0	PATTERN_BYTES_0_1	R/W	0h	Bytes 0 (LSbyte) + 1 of the configured pattern. Each byte can be masked separately RXF_PATTERN_BYTE_MASK registers

7.6.1.60 RXF_PATTERN_2 Register (Offset = 13Dh) [Reset = 0000h]

RXF_PATTERN_2 is shown in [Table 7-81](#).

Return to the [Summary Table](#).

Table 7-81. RXF_PATTERN_2 Register Field Descriptions

Bit	Field	Type	Reset	Description
15-0	PATTERN_BYTES_2_3	R/W	0h	Bytes 2 + 3 of the configured pattern. Each byte can be masked separately RXF_PATTERN_BYTE_MASK registers

7.6.1.61 RXF_PATTERN_3 Register (Offset = 13Eh) [Reset = 0000h]

RXF_PATTERN_3 is shown in [Table 7-82](#).

Return to the [Summary Table](#).

Table 7-82. RXF_PATTERN_3 Register Field Descriptions

Bit	Field	Type	Reset	Description
15-0	PATTERN_BYTES_4_5	R/W	0h	Bytes 4 + 5 of the configured pattern. Each byte can be masked separately RXF_PATTERN_BYTE_MASK registers

7.6.1.62 RXF_PATTERN_4 Register (Offset = 13Fh) [Reset = 0000h]

RXF_PATTERN_4 is shown in [Table 7-83](#).

Return to the [Summary Table](#).

Table 7-83. RXF_PATTERN_4 Register Field Descriptions

Bit	Field	Type	Reset	Description
15-0	PATTERN_BYTES_6_7	R/W	0h	Bytes 6 + 7 of the configured pattern. Each byte can be masked separately RXF_PATTERN_BYTE_MASK registers

7.6.1.63 RXF_PATTERN_5 Register (Offset = 140h) [Reset = 0000h]

RXF_PATTERN_5 is shown in [Table 7-84](#).

Return to the [Summary Table](#).

Table 7-84. RXF_PATTERN_5 Register Field Descriptions

Bit	Field	Type	Reset	Description
15-0	PATTERN_BYTES_8_9	R/W	0h	Bytes 8 + 9 of the configured pattern. Each byte can be masked separately RXF_PATTERN_BYTE_MASK registers

7.6.1.64 RXF_PATTERN_6 Register (Offset = 141h) [Reset = 0000h]

RXF_PATTERN_6 is shown in [Table 7-85](#).

Return to the [Summary Table](#).

Table 7-85. RXF_PATTERN_6 Register Field Descriptions

Bit	Field	Type	Reset	Description
15-0	PATTERN_BYTES_10_11	R/W	0h	Bytes 10 + 11 of the configured pattern. Each byte can be masked separately RXF_PATTERN_BYTE_MASK registers

7.6.1.65 RXF_PATTERN_7 Register (Offset = 142h) [Reset = 0000h]

RXF_PATTERN_7 is shown in [Table 7-86](#).

Return to the [Summary Table](#).

Table 7-86. RXF_PATTERN_7 Register Field Descriptions

Bit	Field	Type	Reset	Description
15-0	PATTERN_BYTES_12_13	R/W	0h	Bytes 12 + 13 of the configured pattern. Each byte can be masked separately RXF_PATTERN_BYTE_MASK registers

7.6.1.66 RXF_PATTERN_8 Register (Offset = 143h) [Reset = 0000h]

RXF_PATTERN_8 is shown in [Table 7-87](#).

Return to the [Summary Table](#).

Table 7-87. RXF_PATTERN_8 Register Field Descriptions

Bit	Field	Type	Reset	Description
15-0	PATTERN_BYTES_14_15	R/W	0h	Bytes 14 + 15 of the configured pattern. Each byte can be masked separately RXF_PATTERN_BYTE_MASK registers

7.6.1.67 RXF_PATTERN_9 Register (Offset = 144h) [Reset = 0000h]

RXF_PATTERN_9 is shown in [Table 7-88](#).

Return to the [Summary Table](#).

Table 7-88. RXF_PATTERN_9 Register Field Descriptions

Bit	Field	Type	Reset	Description
15-0	PATTERN_BYTES_16_17	R/W	0h	Bytes 16 + 17 of the configured pattern. Each byte can be masked separately RXF_PATTERN_BYTE_MASK registers

7.6.1.68 RXF_PATTERN_10 Register (Offset = 145h) [Reset = 0000h]

RXF_PATTERN_10 is shown in [Table 7-89](#).

Return to the [Summary Table](#).

Table 7-89. RXF_PATTERN_10 Register Field Descriptions

Bit	Field	Type	Reset	Description
15-0	PATTERN_BYTES_18_19	R/W	0h	Bytes 18 + 19 of the configured pattern. Each byte can be masked separately RXF_PATTERN_BYTE_MASK registers

7.6.1.69 RXF_PATTERN_11 Register (Offset = 146h) [Reset = 0000h]

RXF_PATTERN_11 is shown in [Table 7-90](#).

Return to the [Summary Table](#).

Table 7-90. RXF_PATTERN_11 Register Field Descriptions

Bit	Field	Type	Reset	Description
15-0	PATTERN_BYTES_20_21	R/W	0h	Bytes 20 + 21 of the configured pattern. Each byte can be masked separately RXF_PATTERN_BYTE_MASK registers

7.6.1.70 RXF_PATTERN_12 Register (Offset = 147h) [Reset = 0000h]

RXF_PATTERN_12 is shown in [Table 7-91](#).

Return to the [Summary Table](#).

Table 7-91. RXF_PATTERN_12 Register Field Descriptions

Bit	Field	Type	Reset	Description
15-0	PATTERN_BYTES_22_23	R/W	0h	Bytes 22 + 23 of the configured pattern. Each byte can be masked separately RXF_PATTERN_BYTE_MASK registers

7.6.1.71 RXF_PATTERN_13 Register (Offset = 148h) [Reset = 0000h]

RXF_PATTERN_13 is shown in [Table 7-92](#).

Return to the [Summary Table](#).

Table 7-92. RXF_PATTERN_13 Register Field Descriptions

Bit	Field	Type	Reset	Description
15-0	PATTERN_BYTES_24_25	R/W	0h	Bytes 24 + 25 of the configured pattern. Each byte can be masked separately RXF_PATTERN_BYTE_MASK registers

7.6.1.72 RXF_PATTERN_14 Register (Offset = 149h) [Reset = 0000h]

RXF_PATTERN_14 is shown in [Table 7-93](#).

Return to the [Summary Table](#).

Table 7-93. RXF_PATTERN_14 Register Field Descriptions

Bit	Field	Type	Reset	Description
15-0	PATTERN_BYTES_26_27	R/W	0h	Bytes 26 + 27 of the configured pattern. Each byte can be masked separately RXF_PATTERN_BYTE_MASK registers

7.6.1.73 RXF_PATTERN_15 Register (Offset = 14Ah) [Reset = 0000h]

RXF_PATTERN_15 is shown in [Table 7-94](#).

Return to the [Summary Table](#).

Table 7-94. RXF_PATTERN_15 Register Field Descriptions

Bit	Field	Type	Reset	Description
15-0	PATTERN_BYTES_28_29	R/W	0h	Bytes 28 + 29 of the configured pattern. Each byte can be masked separately RXF_PATTERN_BYTE_MASK registers

7.6.1.74 RXF_PATTERN_16 Register (Offset = 14Bh) [Reset = 0000h]

RXF_PATTERN_16 is shown in [Table 7-95](#).

Return to the [Summary Table](#).

Table 7-95. RXF_PATTERN_16 Register Field Descriptions

Bit	Field	Type	Reset	Description
15-0	PATTERN_BYTES_30_31	R/W	0h	Bytes 30 + 31 of the configured pattern. Each byte can be masked separately RXF_PATTERN_BYTE_MASK registers

7.6.1.75 RXF_PATTERN_17 Register (Offset = 14Ch) [Reset = 0000h]

RXF_PATTERN_17 is shown in [Table 7-96](#).

Return to the [Summary Table](#).

Table 7-96. RXF_PATTERN_17 Register Field Descriptions

Bit	Field	Type	Reset	Description
15-0	PATTERN_BYTES_32_33	R/W	0h	Bytes 32 + 33 of the configured pattern. Each byte can be masked separately RXF_PATTERN_BYTE_MASK registers

7.6.1.76 RXF_PATTERN_18 Register (Offset = 14Dh) [Reset = 0000h]

RXF_PATTERN_18 is shown in [Table 7-97](#).

Return to the [Summary Table](#).

Table 7-97. RXF_PATTERN_18 Register Field Descriptions

Bit	Field	Type	Reset	Description
15-0	PATTERN_BYTES_34_35	R/W	0h	Bytes 34 + 35 of the configured pattern. Each byte can be masked separately RXF_PATTERN_BYTE_MASK registers

7.6.1.77 RXF_PATTERN_19 Register (Offset = 14Eh) [Reset = 0000h]

RXF_PATTERN_19 is shown in [Table 7-98](#).

Return to the [Summary Table](#).

Table 7-98. RXF_PATTERN_19 Register Field Descriptions

Bit	Field	Type	Reset	Description
15-0	PATTERN_BYTES_36_37	R/W	0h	Bytes 36 + 37 of the configured pattern. Each byte can be masked separately RXF_PATTERN_BYTE_MASK registers

7.6.1.78 RXF_PATTERN_20 Register (Offset = 14Fh) [Reset = 0000h]

RXF_PATTERN_20 is shown in [Table 7-99](#).

Return to the [Summary Table](#).

Table 7-99. RXF_PATTERN_20 Register Field Descriptions

Bit	Field	Type	Reset	Description
15-0	PATTERN_BYTES_38_39	R/W	0h	Bytes 38 + 39 of the configured pattern. Each byte can be masked separately RXF_PATTERN_BYTE_MASK registers

7.6.1.79 RXF_PATTERN_21 Register (Offset = 150h) [Reset = 0000h]

RXF_PATTERN_21 is shown in [Table 7-100](#).

Return to the [Summary Table](#).

Table 7-100. RXF_PATTERN_21 Register Field Descriptions

Bit	Field	Type	Reset	Description
15-0	PATTERN_BYTES_40_41	R/W	0h	Bytes 40 + 41 of the configured pattern. Each byte can be masked separately RXF_PATTERN_BYTE_MASK registers

7.6.1.80 RXF_PATTERN_22 Register (Offset = 151h) [Reset = 0000h]

RXF_PATTERN_22 is shown in [Table 7-101](#).

Return to the [Summary Table](#).

Table 7-101. RXF_PATTERN_22 Register Field Descriptions

Bit	Field	Type	Reset	Description
15-0	PATTERN_BYTES_42_43	R/W	0h	Bytes 42 + 43 of the configured pattern. Each byte can be masked separately RXF_PATTERN_BYTE_MASK registers

7.6.1.81 RXF_PATTERN_23 Register (Offset = 152h) [Reset = 0000h]

RXF_PATTERN_23 is shown in [Table 7-102](#).

Return to the [Summary Table](#).

Table 7-102. RXF_PATTERN_23 Register Field Descriptions

Bit	Field	Type	Reset	Description
15-0	PATTERN_BYTES_44_45	R/W	0h	Bytes 44 + 45 of the configured pattern. Each byte can be masked separately RXF_PATTERN_BYTE_MASK registers

7.6.1.82 RXF_PATTERN_24 Register (Offset = 153h) [Reset = 0000h]

RXF_PATTERN_24 is shown in [Table 7-103](#).

Return to the [Summary Table](#).

Table 7-103. RXF_PATTERN_24 Register Field Descriptions

Bit	Field	Type	Reset	Description
15-0	PATTERN_BYTES_46_47	R/W	0h	Bytes 46 + 47 of the configured pattern. Each byte can be masked separately RXF_PATTERN_BYTE_MASK registers

7.6.1.83 RXF_PATTERN_25 Register (Offset = 154h) [Reset = 0000h]

RXF_PATTERN_25 is shown in [Table 7-104](#).

Return to the [Summary Table](#).

Table 7-104. RXF_PATTERN_25 Register Field Descriptions

Bit	Field	Type	Reset	Description
15-0	PATTERN_BYTES_48_49	R/W	0h	Bytes 48 + 49 of the configured pattern. Each byte can be masked separately RXF_PATTERN_BYTE_MASK registers

7.6.1.84 RXF_PATTERN_26 Register (Offset = 155h) [Reset = 0000h]

RXF_PATTERN_26 is shown in [Table 7-105](#).

Return to the [Summary Table](#).

Table 7-105. RXF_PATTERN_26 Register Field Descriptions

Bit	Field	Type	Reset	Description
15-0	PATTERN_BYTES_50_51	R/W	0h	Bytes 50 + 51 of the configured pattern. Each byte can be masked separately RXF_PATTERN_BYTE_MASK registers

7.6.1.85 RXF_PATTERN_27 Register (Offset = 156h) [Reset = 0000h]

RXF_PATTERN_27 is shown in [Table 7-106](#).

Return to the [Summary Table](#).

Table 7-106. RXF_PATTERN_27 Register Field Descriptions

Bit	Field	Type	Reset	Description
15-0	PATTERN_BYTES_52_53	R/W	0h	Bytes 52 + 53 of the configured pattern. Each byte can be masked separately RXF_PATTERN_BYTE_MASK registers

7.6.1.86 RXF_PATTERN_28 Register (Offset = 157h) [Reset = 0000h]

RXF_PATTERN_28 is shown in [Table 7-107](#).

Return to the [Summary Table](#).

Table 7-107. RXF_PATTERN_28 Register Field Descriptions

Bit	Field	Type	Reset	Description
15-0	PATTERN_BYTES_54_55	R/W	0h	Bytes 54 + 55 of the configured pattern. Each byte can be masked separately RXF_PATTERN_BYTE_MASK registers

7.6.1.87 RXF_PATTERN_29 Register (Offset = 158h) [Reset = 0000h]

RXF_PATTERN_29 is shown in [Table 7-108](#).

Return to the [Summary Table](#).

Table 7-108. RXF_PATTERN_29 Register Field Descriptions

Bit	Field	Type	Reset	Description
15-0	PATTERN_BYTES_56_57	R/W	0h	Bytes 56 + 57 of the configured pattern. Each byte can be masked separately RXF_PATTERN_BYTE_MASK registers

7.6.1.88 RXF_PATTERN_30 Register (Offset = 159h) [Reset = 0000h]

RXF_PATTERN_30 is shown in [Table 7-109](#).

Return to the [Summary Table](#).

Table 7-109. RXF_PATTERN_30 Register Field Descriptions

Bit	Field	Type	Reset	Description
15-0	PATTERN_BYTES_58_59	R/W	0h	Bytes 58 + 59 of the configured pattern. Each byte can be masked separately RXF_PATTERN_BYTE_MASK registers

7.6.1.89 RXF_PATTERN_31 Register (Offset = 15Ah) [Reset = 0000h]

RXF_PATTERN_31 is shown in [Table 7-110](#).

Return to the [Summary Table](#).

Table 7-110. RXF_PATTERN_31 Register Field Descriptions

Bit	Field	Type	Reset	Description
15-0	PATTERN_BYTES_60_61	R/W	0h	Bytes 60 + 61 of the configured pattern. Each byte can be masked separately RXF_PATTERN_BYTE_MASK registers

7.6.1.90 RXF_PATTERN_32 Register (Offset = 15Bh) [Reset = 0000h]

RXF_PATTERN_32 is shown in [Table 7-111](#).

Return to the [Summary Table](#).

Table 7-111. RXF_PATTERN_32 Register Field Descriptions

Bit	Field	Type	Reset	Description
15-0	PATTERN_BYTES_62_63	R/W	0h	Bytes 62 + 63 of the configured pattern. Each byte can be masked separately RXF_PATTERN_BYTE_MASK registers

7.6.1.91 RXF_PATTERN_BYTE_MASK_1 Register (Offset = 15Ch) [Reset = 0000h]

RXF_PATTERN_BYTE_MASK_1 is shown in [Table 7-112](#).

Return to the [Summary Table](#).

Table 7-112. RXF_PATTERN_BYTE_MASK_1 Register Field Descriptions

Bit	Field	Type	Reset	Description
15-0	PATTERN_BYTES_MASK_0_15	R/W	0h	Masks for bytes 0 to 15 of the pattern. For each byte: '1' means masked

7.6.1.92 RXF_PATTERN_BYTE_MASK_2 Register (Offset = 15Dh) [Reset = 0000h]

RXF_PATTERN_BYTE_MASK_2 is shown in [Table 7-113](#).

Return to the [Summary Table](#).

Table 7-113. RXF_PATTERN_BYTE_MASK_2 Register Field Descriptions

Bit	Field	Type	Reset	Description
15-0	PATTERN_BYTES_MASK_16_31	R/W	0h	Masks for bytes 16 to 31 of the pattern. For each byte: '1' means masked

7.6.1.93 RXF_PATTERN_BYTE_MASK_3 Register (Offset = 15Eh) [Reset = 0000h]

RXF_PATTERN_BYTE_MASK_3 is shown in [Table 7-114](#).

Return to the [Summary Table](#).

Table 7-114. RXF_PATTERN_BYTE_MASK_3 Register Field Descriptions

Bit	Field	Type	Reset	Description
15-0	PATTERN_BYTES_MASK_32_47	R/W	0h	Masks for bytes 32 to 47 of the pattern. For each byte: '1' means masked

7.6.1.94 RXF_PATTERN_BYTE_MASK_4 Register (Offset = 15Fh) [Reset = 0000h]

RXF_PATTERN_BYTE_MASK_4 is shown in [Table 7-115](#).

Return to the [Summary Table](#).

Table 7-115. RXF_PATTERN_BYTE_MASK_4 Register Field Descriptions

Bit	Field	Type	Reset	Description
15-0	PATTERN_BYTES_MASK_48_63	R/W	0h	Masks for bytes 48 to 63 of the pattern. For each byte: '1' means masked

7.6.1.95 10M_SGMII_CFG Register (Offset = 16Fh) [Reset = 0115h]

10M_SGMII_CFG is shown in [Table 7-116](#).

Return to the [Summary Table](#).

Table 7-116. 10M_SGMII_CFG Register Field Descriptions

Bit	Field	Type	Reset	Description
15-8	RESERVED	R	0h	Reserved
7	10M_SGMII_RATE_ADAPT_DISABLE	R/W	0h	Rate Adaption Disable 0h = Rate Adaption Enabled 1h = Rate Adaption Disabled
6	RESERVED	R/W	0h	Reserved
5	RESERVED	R/W	0h	Reserved
4	RESERVED	R/W	0h	Reserved
3-0	RESERVED	R/W	0h	Reserved

7.6.1.96 IO_MUX_CFG Register (Offset = 170h) [Reset = 0CX0h]

IO_MUX_CFG is shown in [Table 7-117](#).

Return to the [Summary Table](#).

Table 7-117. IO_MUX_CFG Register Field Descriptions

Bit	Field	Type	Reset	Description
15-13	RESERVED	R	0h	Reserved

Table 7-117. IO_MUX_CFG Register Field Descriptions (continued)

Bit	Field	Type	Reset	Description
12-8	CLK_O_SEL	R/W	Ch	Select clock output source 0h = Channel A receive clock 1h = Channel B receive clock 2h = Channel C receive clock 3h = Channel D receive clock 4h = Channel A receive clock divided by 5 5h = Channel B receive clock divided by 5 6h = Channel C receive clock divided by 5 7h = Channel D receive clock divided by 5 8h = Channel A transmit clock 9h = Channel B transmit clock Ah = Channel C transmit clock Bh = Channel D transmit clock Ch = Reference clock (synchronous to XI input clock) Note: Reg 0xC6 must be set equal to 0x10 before CLK_O_SEL can be modified
7	RESERVED	R	0h	Reserved
6	CLK_O_DISABLE	R/W	X	Clock Out Disable 0h = Clock Out Enable 1h = Clock Out Disable
5	RESERVED	R/W	0h	Reserved
4-0	MAC_IMPEDANCE_CTRL	R/W	10h	Impedance Control for MAC I/Os: Output impedance approximate range from 35-70 Ω in 32 steps. Lowest being 11111 and highest being 00000. Range and Step size will vary with process. Default is set to 50 Ω by trim but the default register value can vary by process. Non default values of MAC I/O impedance can be used based on trace impedance. Mismatch between device and trace impedance can cause voltage overshoot and undershoot.

7.6.1.97 IO_MUX_GPIO_CTRL2 Register (Offset = 172h) [Reset = 0000h]

IO_MUX_GPIO_CTRL2 is shown in [Table 7-118](#).

Return to the [Summary Table](#).

Table 7-118. IO_MUX_GPIO_CTRL2 Register Field Descriptions

Bit	Field	Type	Reset	Description
15-12	RESERVED	R	0h	Reserved
11-8	RESERVED	R	0h	Reserved
7-4	RESERVED	R	0h	Reserved
3-0	RESERVED	R	0h	Reserved

7.6.1.98 TDR_GEN_CFG1 Register (Offset = 180h) [Reset = 3A90h]

TDR_GEN_CFG1 is shown in [Table 7-119](#).

Return to the [Summary Table](#).

Table 7-119. TDR_GEN_CFG1 Register Field Descriptions

Bit	Field	Type	Reset	Description
12	TDR_CH_CD_BYPASS	R/W	0h	Bypass channel C and D in TDR tests
11	TDR_CROSS_MODE_DISABLE	R/W	0h	If set, disable cross mode option - never check the cross (Listen only to the same channel you transmit)
10	TDR_NLP_CHECK	R/W	1h	If set, check for NLPs during silence

Table 7-119. TDR_GEN_CFG1 Register Field Descriptions (continued)

Bit	Field	Type	Reset	Description
9-7	TDR_AVG_NUM	R/W	6h	Number Of TDR Cycles to Average: 000b = 1 TDR cycle 001b = 2 TDR cycles 010b = 4 TDR cycles 011b = 8 TDR cycles 100b = 16 TDR cycles 101b = 32 TDR cycles 110b = 64 TDR cycles (default) 111b = Reserved
6-4	TDR_SEG_NUM	R/W	5h	Number of TDR segments to check
3-0	TDR_CYCLE_TIME	R/W	2h	Number of micro-seconds in each TDR cycle

7.6.1.99 TDR_GEN_CFG2 Register (Offset = 181h) [Reset = C850h]

TDR_GEN_CFG2 is shown in [Table 7-120](#).

Return to the [Summary Table](#).

Table 7-120. TDR_GEN_CFG2 Register Field Descriptions

Bit	Field	Type	Reset	Description
15-8	TDR_SILENCE_TH	R/W	C8h	Energy detection threshold
7-6	TDR_POST_SILENCE_TIME	R/W	1h	timer for tdr to look for energy after TDR transaction, if energy detected this is fail tdr
5-4	TDR_PRE_SILENCE_TIME	R/W	1h	timer for tdr to look for energy before starting , if energy detected this is fail tdr
3-0	RESERVED	R	0h	Reserved

7.6.1.100 TDR_SEG_DURATION1 Register (Offset = 182h) [Reset = 5326h]

TDR_SEG_DURATION1 is shown in [Table 7-121](#).

Return to the [Summary Table](#).

Table 7-121. TDR_SEG_DURATION1 Register Field Descriptions

Bit	Field	Type	Reset	Description
15	RESERVED	R	0h	Reserved
14-10	TDR_SEG_DURATION_SEG3	R/W	14h	Number of 125MHz clock cycles to run for segment #3
9-5	TDR_SEG_DURATION_SEG2	R/W	19h	Number of 125MHz clock cycles to run for segment #2
4-0	TDR_SEG_DURATION_SEG1	R/W	6h	Number of 125MHz clock cycles to run for segment #1

7.6.1.101 TDR_SEG_DURATION2 Register (Offset = 183h) [Reset = A01Eh]

TDR_SEG_DURATION2 is shown in [Table 7-122](#).

Return to the [Summary Table](#).

Table 7-122. TDR_SEG_DURATION2 Register Field Descriptions

Bit	Field	Type	Reset	Description
15-8	TDR_SEG_DURATION_SEG5	R/W	A0h	Number of 125MHz clock cycles to run for segment #5
7-6	RESERVED	R	0h	Reserved
5-0	TDR_SEG_DURATION_SEG4	R/W	1Eh	Number of 125MHz clock cycles to run for segment #4

7.6.1.102 TDR_GEN_CFG3 Register (Offset = 184h) [Reset = E976h]

TDR_GEN_CFG3 is shown in [Table 7-123](#).

Return to the [Summary Table](#).

Table 7-123. TDR_GEN_CFG3 Register Field Descriptions

Bit	Field	Type	Reset	Description
15-12	TDR_FWD_SHADOW_SE G4	R/W	Eh	Indicates how much time to wait after max level before declaring we found a peak in segment #4
11-8	TDR_FWD_SHADOW_SE G3	R/W	9h	Indicates how much time to wait after max level before declaring we found a peak in segment #3
7	RESERVED	R	0h	Reserved
6-4	TDR_FWD_SHADOW_SE G2	R/W	7h	Indicates how much time to wait after max level before declaring we found a peak in segment #2
3	RESERVED	R	0h	Reserved
2-0	TDR_FWD_SHADOW_SE G1	R/W	6h	Indicates how much time to wait after max level before declaring we found a peak in segment #1

7.6.1.103 TDR_GEN_CFG4 Register (Offset = 185h) [Reset = 19CFh]

TDR_GEN_CFG4 is shown in [Table 7-124](#).

Return to the [Summary Table](#).

Table 7-124. TDR_GEN_CFG4 Register Field Descriptions

Bit	Field	Type	Reset	Description
15-14	RESERVED	R	0h	Reserved
13-11	TDR_SDW_AVG_LOC	R/W	3h	how much to look between segments to search average peak
10-9	RESERVED	R	0h	Reserved
8	TDR_TX_TYPE_SEG5	R/W	1h	the tx type (10/100) for this segment
7	TDR_TX_TYPE_SEG4	R/W	1h	the tx type (10/100) for this segment
6	TDR_TX_TYPE_SEG3	R/W	1h	the tx type (10/100) for this segment
5	TDR_TX_TYPE_SEG2	R/W	0h	the tx type (10/100) for this segment
4	TDR_TX_TYPE_SEG1	R/W	0h	the tx type (10/100) for this segment
3-0	TDR_FWD_SHADOW_SE G5	R/W	Fh	Indicates how much time to wait after max level before declaring we found a peak in segment #5

7.6.1.104 TDR_PEAKE_LOC_A_0_1 Register (Offset = 190h) [Reset = 0000h]

TDR_PEAKE_LOC_A_0_1 is shown in [Table 7-125](#).

Return to the [Summary Table](#).

Table 7-125. TDR_PEAKE_LOC_A_0_1 Register Field Descriptions

Bit	Field	Type	Reset	Description
15-8	TDR_PEAKE_LOC_A_1	R	0h	Found peak location 1 in channel A
7-0	TDR_PEAKE_LOC_A_0	R	0h	Found peak location 0 in channel A

7.6.1.105 TDR_PEAKE_LOC_A_2_3 Register (Offset = 191h) [Reset = 0000h]

TDR_PEAKE_LOC_A_2_3 is shown in [Table 7-126](#).

Return to the [Summary Table](#).

Table 7-126. TDR_PEAKS_LOC_A_2_3 Register Field Descriptions

Bit	Field	Type	Reset	Description
15-8	TDR_PEAKS_LOC_A_3	R	0h	Found peak location 3 in channel A
7-0	TDR_PEAKS_LOC_A_2	R	0h	Found peak location 2 in channel A

7.6.1.106 TDR_PEAKS_LOC_A_4_B_0 Register (Offset = 192h) [Reset = 0000h]

TDR_PEAKS_LOC_A_4_B_0 is shown in [Table 7-127](#).

Return to the [Summary Table](#).

Table 7-127. TDR_PEAKS_LOC_A_4_B_0 Register Field Descriptions

Bit	Field	Type	Reset	Description
15-8	TDR_PEAKS_LOC_B_0	R	0h	Found peak location 0 in channel B
7-0	TDR_PEAKS_LOC_A_4	R	0h	Found peak location 4 in channel A

7.6.1.107 TDR_PEAKS_LOC_B_1_2 Register (Offset = 193h) [Reset = 0000h]

TDR_PEAKS_LOC_B_1_2 is shown in [Table 7-128](#).

Return to the [Summary Table](#).

Table 7-128. TDR_PEAKS_LOC_B_1_2 Register Field Descriptions

Bit	Field	Type	Reset	Description
15-8	TDR_PEAKS_LOC_B_2	R	0h	Found peak location 2 in channel B
7-0	TDR_PEAKS_LOC_B_1	R	0h	Found peak location 1 in channel B

7.6.1.108 TDR_PEAKS_LOC_B_3_4 Register (Offset = 194h) [Reset = 0000h]

TDR_PEAKS_LOC_B_3_4 is shown in [Table 7-129](#).

Return to the [Summary Table](#).

Table 7-129. TDR_PEAKS_LOC_B_3_4 Register Field Descriptions

Bit	Field	Type	Reset	Description
15-8	TDR_PEAKS_LOC_B_4	R	0h	Found peak location 4 in channel B
7-0	TDR_PEAKS_LOC_B_3	R	0h	Found peak location 3 in channel B

7.6.1.109 TDR_PEAKS_LOC_C_0_1 Register (Offset = 195h) [Reset = 0000h]

TDR_PEAKS_LOC_C_0_1 is shown in [Table 7-130](#).

Return to the [Summary Table](#).

Table 7-130. TDR_PEAKS_LOC_C_0_1 Register Field Descriptions

Bit	Field	Type	Reset	Description
15-8	TDR_PEAKS_LOC_C_1	R	0h	Found peak location 1 in channel C
7-0	TDR_PEAKS_LOC_C_0	R	0h	Found peak location 0 in channel C

7.6.1.110 TDR_PEAKS_LOC_C_2_3 Register (Offset = 196h) [Reset = 0000h]

TDR_PEAKS_LOC_C_2_3 is shown in [Table 7-131](#).

Return to the [Summary Table](#).

Table 7-131. TDR_PEAKS_LOC_C_2_3 Register Field Descriptions

Bit	Field	Type	Reset	Description
15-8	TDR_PEAKS_LOC_C_3	R	0h	Found peak location 3 in channel C
7-0	TDR_PEAKS_LOC_C_2	R	0h	Found peak location 2 in channel C

7.6.1.111 TDR_PEAKS_LOC_C_4_D_0 Register (Offset = 197h) [Reset = 0000h]

TDR_PEAKS_LOC_C_4_D_0 is shown in [Table 7-132](#).

Return to the [Summary Table](#).

Table 7-132. TDR_PEAKS_LOC_C_4_D_0 Register Field Descriptions

Bit	Field	Type	Reset	Description
15-8	TDR_PEAKS_LOC_D_0	R	0h	Found peak location 0 in channel D
7-0	TDR_PEAKS_LOC_C_4	R	0h	Found peak location 4 in channel C

7.6.1.112 TDR_PEAKS_LOC_D_1_2 Register (Offset = 198h) [Reset = 0000h]

TDR_PEAKS_LOC_D_1_2 is shown in [Table 7-133](#).

Return to the [Summary Table](#).

Table 7-133. TDR_PEAKS_LOC_D_1_2 Register Field Descriptions

Bit	Field	Type	Reset	Description
15-8	TDR_PEAKS_LOC_D_2	R	0h	Found peak location 2 in channel D
7-0	TDR_PEAKS_LOC_D_1	R	0h	Found peak location 1 in channel D

7.6.1.113 TDR_PEAKS_LOC_D_3_4 Register (Offset = 199h) [Reset = 0000h]

TDR_PEAKS_LOC_D_3_4 is shown in [Table 7-134](#).

Return to the [Summary Table](#).

Table 7-134. TDR_PEAKS_LOC_D_3_4 Register Field Descriptions

Bit	Field	Type	Reset	Description
15-8	TDR_PEAKS_LOC_D_4	R	0h	Found peak location 4 in channel D
7-0	TDR_PEAKS_LOC_D_3	R	0h	Found peak location 3 in channel D

7.6.1.114 TDR_GEN_STATUS Register (Offset = 1A4h) [Reset = 0000h]

TDR_GEN_STATUS is shown in [Table 7-135](#).

Return to the [Summary Table](#).

Table 7-135. TDR_GEN_STATUS Register Field Descriptions

Bit	Field	Type	Reset	Description
15-12	RESERVED	R	0h	Reserved
11	TDR_P_LOC_CROSS_MODE_D	R	0h	Peak found at cross mode in channel D
10	TDR_P_LOC_CROSS_MODE_C	R	0h	Peak found at cross mode in channel C
9	TDR_P_LOC_CROSS_MODE_B	R	0h	Peak found at cross mode in channel B
8	TDR_P_LOC_CROSS_MODE_A	R	0h	Peak found at cross mode in channel A

Table 7-135. TDR_GEN_STATUS Register Field Descriptions (continued)

Bit	Field	Type	Reset	Description
7	TDR_P_LOC_OVERFLOW_W_D	R	0h	Total number of peaks in current segment reached max value of 5 in channel D
6	TDR_P_LOC_OVERFLOW_W_C	R	0h	Total number of peaks in current segment reached max value of 5 in channel C
5	TDR_P_LOC_OVERFLOW_W_B	R	0h	Total number of peaks in current segment reached max value of 5 in channel B
4	TDR_P_LOC_OVERFLOW_W_A	R	0h	Total number of peaks in current segment reached max value of 5 in channel A
3	TDR_SEG1_HIGH_CROSS_D	R	0h	Peak crossed high threshold of segment #1 in channel D
2	TDR_SEG1_HIGH_CROSS_C	R	0h	peak crossed high threshold of segment #1 in channel C
1	TDR_SEG1_HIGH_CROSS_B	R	0h	peak crossed high threshold of segment #1 in channel B
0	TDR_SEG1_HIGH_CROSS_A	R	0h	peak crossed high threshold of segment #1 in channel A

7.6.1.115 TDR_PEAKE_SIGN_A_B Register (Offset = 1A5h) [Reset = 0000h]

TDR_PEAKE_SIGN_A_B is shown in [Table 7-136](#).

Return to the [Summary Table](#).

Table 7-136. TDR_PEAKE_SIGN_A_B Register Field Descriptions

Bit	Field	Type	Reset	Description
15-10	RESERVED	R	0h	Reserved
9	TDR_PEAKE_SIGN_B_4	R	0h	found peaks sign 4 in channel B
8	TDR_PEAKE_SIGN_B_3	R	0h	found peaks sign 3 in channel B
7	TDR_PEAKE_SIGN_B_2	R	0h	found peaks sign 2 in channel B
6	TDR_PEAKE_SIGN_B_1	R	0h	found peaks sign 1 in channel B
5	TDR_PEAKE_SIGN_B_0	R	0h	found peaks sign 0 in channel B
4	TDR_PEAKE_SIGN_A_4	R	0h	found peaks sign 4 in channel A
3	TDR_PEAKE_SIGN_A_3	R	0h	found peaks sign 3 in channel A
2	TDR_PEAKE_SIGN_A_2	R	0h	found peaks sign 2 in channel A
1	TDR_PEAKE_SIGN_A_1	R	0h	found peaks sign 1 in channel A
0	TDR_PEAKE_SIGN_A_0	R	0h	found peaks sign 0 in channel A

7.6.1.116 TDR_PEAKE_SIGN_C_D Register (Offset = 1A6h) [Reset = 0000h]

TDR_PEAKE_SIGN_C_D is shown in [Table 7-137](#).

Return to the [Summary Table](#).

Table 7-137. TDR_PEAKE_SIGN_C_D Register Field Descriptions

Bit	Field	Type	Reset	Description
15-10	RESERVED	R	0h	Reserved
9	TDR_PEAKE_SIGN_D_4	R	0h	found peaks sign 4 in channel D
8	TDR_PEAKE_SIGN_D_3	R	0h	found peaks sign 3 in channel D
7	TDR_PEAKE_SIGN_D_2	R	0h	found peaks sign 2 in channel D
6	TDR_PEAKE_SIGN_D_1	R	0h	found peaks sign 1 in channel D
5	TDR_PEAKE_SIGN_D_0	R	0h	found peaks sign 0 in channel D

Table 7-137. TDR_PEAKS_SIGN_C_D Register Field Descriptions (continued)

Bit	Field	Type	Reset	Description
4	TDR_PEAKS_SIGN_C_4	R	0h	found peaks sign 4 in channel C
3	TDR_PEAKS_SIGN_C_3	R	0h	found peaks sign 3 in channel C
2	TDR_PEAKS_SIGN_C_2	R	0h	found peaks sign 2 in channel C
1	TDR_PEAKS_SIGN_C_1	R	0h	found peaks sign 1 in channel C
0	TDR_PEAKS_SIGN_C_0	R	0h	found peaks sign 0 in channel C

7.6.1.117 DBG_PRBS_PKT_CNT_1 Register (Offset = 1A8h) [Reset = 0000h]

DBG_PRBS_PKT_CNT_1 is shown in [Table 7-138](#).

Return to the [Summary Table](#).

Table 7-138. DBG_PRBS_PKT_CNT_1 Register Field Descriptions

Bit	Field	Type	Reset	Description
15-0	PRBS_PKT_CNT_15_0	R	0h	Holds bits [15:0] of number of total packets that received by the PRBS checker. Value in this register is locked when write is done to register DBG_PRBS_ERR_CNT bit[0] or bit[1]. When PRBS Count Mode set to zero, count stops on 0xFFFFFFFF (see register 0x0016)

7.6.1.118 DBG_PRBS_PKT_CNT_2 Register (Offset = 1A9h) [Reset = 0000h]

DBG_PRBS_PKT_CNT_2 is shown in [Table 7-139](#).

Return to the [Summary Table](#).

Table 7-139. DBG_PRBS_PKT_CNT_2 Register Field Descriptions

Bit	Field	Type	Reset	Description
15-0	PRBS_PKT_CNT_31_16	R	0h	Holds bits [31:16] of number of total packets that received by the PRBS checker. Value in this register is locked when write is done to register DBG_PRBS_ERR_CNT bit[0] or bit[1]. When PRBS Count Mode set to zero, count stops on 0xFFFFFFFF (see register 0x0016)

7.6.1.119 OP_MODE_DECODE Register (Offset = 1DFh) [Reset = 0040h]

OP_MODE_DECODE is shown in [Table 7-140](#).

Return to the [Summary Table](#).

Table 7-140. OP_MODE_DECODE Register Field Descriptions

Bit	Field	Type	Reset	Description
15-9	RESERVED	R	0h	Reserved
8-7	RESERVED	R	0h	Reserved
6	BRIDGE_MODE_RGMII_MAC	R/W	1h	0h = RGMII to SGMII Bridge 1h = SGMII to RGMII Bridge
5	RGMII_MII_SEL	R/W	0h	0h = RGMII 1h = MII
4	RESERVED	R	0h	Reserved
3	RESERVED	R	0h	Reserved

Table 7-140. OP_MODE_DECODE Register Field Descriptions (continued)

Bit	Field	Type	Reset	Description
2-0	CFG_OPMODE	R/W	0h	Operation Mode 0h = RGMII to Copper 1h = RGMII to 1000Base-X 2h = RGMII to 100Base-FX 3h = RGMII to SGMII 4h = 1000Base-T to 1000Base-X 5h = 100Base-T to 100Base-FX 6h = SGMII to Copper 7h = Reserved

7.6.1.120 GPIO_MUX_CTRL Register (Offset = 1E0h) [Reset = 417Ah]

GPIO_MUX_CTRL is shown in [Table 7-141](#).

Return to the [Summary Table](#).

Table 7-141. GPIO_MUX_CTRL Register Field Descriptions

Bit	Field	Type	Reset	Description
15-12	RESERVED	R/W	0h	Reserved
11-8	RESERVED	R/W	0h	Reserved
7-4	JTAG_TDO_GPIO_1_CTRL	R/W	7h	See bits [3:0] for GPIO control options. If either type of SFD is enabled, this pin will be automatically configured to TX_SFD.
3-0	LED_2_GPIO_0_CTRL	R/W	Ah	Following options are available for GPIO control. If either type of SFD is enabled, this pin will be automatically configured to RX_SFD. 0h = CLK_OUT 1h = RESERVED 2h = INT 3h = Link status 4h = RESERVED 5h = Transmit SFD 6h = Receive SFD 7h = WOL 8h = Energy detect(1000Base-T and 100Base-TX only) 9h = PRBS errors Ah = LED_2 Bh = LED_GPIO(3) Ch = CRS Dh = COL Eh = constant '0' Fh = constant '1'

7.6.1.121 MC_LINK_LOSS Register (Offset = 1ECh) [Reset = 1FFDh]

MC_LINK_LOSS is shown in [Table 7-142](#).

Return to the [Summary Table](#).

Table 7-142. MC_LINK_LOSS Register Field Descriptions

Bit	Field	Type	Reset	Description
15-13	RESERVED	R/W	0h	Reserved
12-9	RESERVED	R/W	0h	Reserved
8	RESERVED	R/W	0h	Reserved
7	RESERVED	R/W	0h	Reserved
6	RESERVED	R/W	0h	Reserved
5	RESERVED	R/W	0h	Reserved
4	RESERVED	R/W	0h	Reserved

Table 7-142. MC_LINK_LOSS Register Field Descriptions (continued)

Bit	Field	Type	Reset	Description
3	RESERVED	R/W	0h	Reserved
2-1	RESERVED	R/W	0h	Reserved
0	CFG_NO_LINK_LINK_LOSS_EN	R/W	1h	Disables MC link_loss feature when there is no_link for given time. 0h = Enable link loss feature 1h = Disable link loss feature

7.6.1.122 FX_CTRL Register (Offset = C00h) [Reset = 1140h]

FX_CTRL is shown in [Table 7-143](#).

Return to the [Summary Table](#).

Registers after 0xC00 are common for Fiber, SGMII IP blocks for RGMII-to-SGMII, SGMII-to-RGMII, and Media Converter.

Table 7-143. FX_CTRL Register Field Descriptions

Bit	Field	Type	Reset	Description
15	CTRL0_RESET	R/W	0h	Controls reset in Fiber mode. This bit is automatically cleared after reset is completed. 0h = Normal Operation 1h = Reset.
14	CTRL0_LOOPBACK	R/W	0h	100BASE-X, 1000BASE-FX and RGMII-SGMII, SGMII-RGMII MAC loopback. 0h = Disable MAC loopback 1h = Enable MAC Loopback
13	CTRL0_SPEED_SEL_LSB	R/W	0h	Speed selection bits LSB[13] and MSB[6] are used to control the data rate of the ethernet link when in Fiber Ethernet mode. These bits are also affected by straps. 0h = 10Mbps 1h = 100Mbps 2h = 1000Mbps 3h = Reserved
12	CTRL0_ANEG_EN	R/W	1h	Enable 1000BASE-X, R2S, S2R Bridge mode Auto-negotiation. Controlled by strap. 0h = Disable 1h = Enable
11	CTRL0_PWRDN	R/W	0h	Power Down SGMII for R2S, S2R, 1000BX, 100FX. Digital is in reset. 0h = Normal operation 1h = Power Down
10	CTRL0_ISOLATE	R/W	0h	Isolate MAC interface. Used in 1000BX, 100FX and RGMII-SGMII mode. N/A in SGMII-RGMII mode. 0h = Normal operation 1h = Isolate
9	CTRL0_RESTART_AN	R/W	0h	Writing 1 to this control bit restarts Autoneg in SGMII and 1000B-X mode. It is self-cleared by hardware. 0h = Normal operation 1h = Restart 1000BASE-X/SGMII Auto-Negotiation Process
8	CTRL0_DUPLEX_MODE	R/W	1h	Forced Duplex mode. Applicable only in MII-100FX mode. 0h = Half duplex mode 1h = Full duplex mode
7	CTRL0_COL_TEST	R/W	0h	Used to test collision functionality. Setting this bit asserts collision on just asserting tx_en
6	CTRL0_SPEED_SEL_MSB	R/W	1h	Forced Speed for SGMII only when Autoneg is disabled. Controlled by straps. See bit 13 of this register.
5-0	RESERVED	R/W	0h	Reserved

7.6.1.123 FX_STS Register (Offset = C01h) [Reset = 6149h]

FX_STS is shown in [Table 7-144](#).

Return to the [Summary Table](#).

Table 7-144. FX_STS Register Field Descriptions

Bit	Field	Type	Reset	Description
15	STTS_100B_T4	R	0h	Return Always 0. Device doesn't support 100BASE-T4 mode
14	STTS_100B_X_FD	R	1h	Return Always 1. Device supports 100BASE-FX Full-Duplex
13	STTS_100B_X_HD	R	1h	Return Always 1. Device supports 100BASE-FX Half-Duplex
12	STTS_10B_FD	R	0h	Return Always 0. Device doesn't support 10Mbps fiber mode
11	STTS_10B_HD	R	0h	Return Always 0. Device doesn't support 10Mbps fiber mode
10	STTS_100B_T2_FD	R	0h	Return Always 0. Device doesn't support 100BASE-T2 mode
9	STTS_100B_T2_HD	R	0h	Return Always 0. Device doesn't support 100BASE-T2 mode
8	STTS_EXTENDED_STAT US	R	1h	Return Always 1. Extended status information in register15
7	RESERVED	R	0h	Reserved
6	STTS_MF_PREAMBLE_S UPRSN	R	1h	Return Always 1. Phy accepts management frames with preamble suppressed.
5	STTS_ANEG_COMPLET E	R	0h	1: Auto negotiation process complete 0:Auto negotiation process not complete
4	STTS_REMOTE_FAULT	R	0h	1: Remote fault condition detected 0:Remote fault condition not detected
3	STTS_ANEG_ABILITY	R	1h	Return Always 1. Device capable of performing Auto-Negotiation
2	STTS_LINK_STATUS	R	0h	1: link-up 0: link down Indicates 100FX link-up in 100FX and 100FX MC Mode. Indicates 1000X link-up in 1000X and 1000X MC mode. In RGMII-SGMII mode, it indicates SGMII link-up and LP link up if Autoneg is enabled else(if autoneg disabled) it indicates SGMII link-up. In SGMII-RGMII mode, it indicates LP link-up
1	STTS_JABBER_DET	R	0h	Return 0.
0	STTS_EXTENDED_CAPA BILITY	R	1h	Return Always 1. Device supports Extended register capabilities

7.6.1.124 FX_PHYID1 Register (Offset = C02h) [Reset = 2000h]

FX_PHYID1 is shown in [Table 7-145](#).

Return to the [Summary Table](#).

Table 7-145. FX_PHYID1 Register Field Descriptions

Bit	Field	Type	Reset	Description
15-14	RESERVED	R	0h	Reserved
13-0	OUI_6_19_FIBER	R	2000h	Organizationally Unique Identifier Bits 19:6

7.6.1.125 FX_PHYID2 Register (Offset = C03h) [Reset = A0F1h]

FX_PHYID2 is shown in [Table 7-146](#).

Return to the [Summary Table](#).

Table 7-146. FX_PHYID2 Register Field Descriptions

Bit	Field	Type	Reset	Description
15-10	OUI_0_5_FIBER	R	28h	Organizationally Unique Identifier Bits 5:0

Table 7-146. FX_PHYID2 Register Field Descriptions (continued)

Bit	Field	Type	Reset	Description
9-4	MODEL_NUM_FIBER	R	Fh	model number
3-0	REVISION_NUM_FIBER	R	1h	revision number

7.6.1.126 FX_ANADV Register (Offset = C04h) [Reset = 0020h]

FX_ANADV is shown in [Table 7-147](#).

Return to the [Summary Table](#).

Table 7-147. FX_ANADV Register Field Descriptions

Bit	Field	Type	Reset	Description
15	BP_NEXT_PAGE	R/W	0h	Set this bit if next page needs to be advertised. 1 = Advertise 0 = Not advertised
14	BP_ACK	R	0h	Always return 0
13-12	BP_REMOTE_FAULT	R/W	0h	00 = LINK_OK 01=OFFLINE 10=LINK_FAILURE 11=AUTO_ERROR
11-9	RESERVED	R	0h	Reserved
8	BP_ASYMMETRIC_PAUSE	R/W	0h	1 = Asymmetric Pause 0 = No asymmetric Pause
7	BP_PAUSE	R/W	0h	1 = MAC PAUSE 0 = No MAC PAUSE
6	BP_HALF_DUPLEX	R/W	0h	1 = Advertise 0 = Not advertised
5	BP_FULL_DUPLEX	R/W	1h	1 = Advertise 0 = Not advertised
4-0	BP_RSVD1	R	0h	Reserved. Set to 00000

7.6.1.127 FX_LPABL Register (Offset = C05h) [Reset = 0000h]

FX_LPABL is shown in [Table 7-148](#).

Return to the [Summary Table](#).

Table 7-148. FX_LPABL Register Field Descriptions

Bit	Field	Type	Reset	Description
15	LP_ABILITY_NEXT_PAGE	R	0h	0h = LP is not capable of next page 1h = LP is capable of next page
14	LP_ABILITY_ACK	R	0h	0h = LP has not acknowledged that it has received link code word 1h = LP acknowledges that it has received link code word
13-12	LP_ABILITY_REMOTE_FAULT	R	0h	Received Remote fault from LP. 0h = LINK_OK 1h = OFFLINE 2h = LINK_FAILURE 3h = AUTO_ERROR
11-9	RESERVED	R	0h	Reserved
8	LP_ABILITY_ASYMMETRIC_PAUSE	R	0h	0h = LP does not request asymmetric pause 1h = LP requests of asymmetric pause
7	LP_ABILITY_PAUSE	R	0h	0h = LP is not capable of pause operation 1h = LP is capable of pause operation
6	LP_ABILITY_HALF_DUPLEX	R	0h	0h = LP is not 1000BASE-X Half-duplex capable 1h = LP is 1000BASE-X Half-duplex capable
5	LP_ABILITY_FULL_DUPLEX	R	0h	0h = LP is not 1000BASE-X Full-duplex capable 1h = LP is 1000BASE-X Full-duplex capable
4-0	RESERVED	R	0h	Reserved

7.6.1.128 FX_ANEXP Register (Offset = C06h) [Reset = 0000h]

FX_ANEXP is shown in [Table 7-149](#).

Return to the [Summary Table](#).

Table 7-149. FX_ANEXP Register Field Descriptions

Bit	Field	Type	Reset	Description
15-4	RESERVED	R	0h	Reserved
3	AN_EXP_LP_NEXT_PAGE_ABLE	R	0h	1: Link partner is Next page able 0: Link partner is not next page able Bit is set to 1 when device receives base page with NP bit (bit 15) set to 1. It is cleared when Autoneg state goes to AN_ENABLE. It is expected that NP bit will be set to 0 in SGMII mode as SGMII doesn't supports next page.
2	AN_EXP_LOCAL_NEXT_PAGE_ABLE	R	0h	1 : Local device is next page able 0 : Local device is not next page able This bit is set to 1 in fiber 1000BASE-X mode. it is set to 0 in SGMII mode.
1	AN_EXP_PAGE_RECEIVED	R	0h	1 : A new page(base page or next page) has been received 0 : No new page has been received Status is latched when new page is received by the device. It is cleared when SW reads this register.
0	AN_EXP_LP_AUTO_NEG_ABLE	R	0h	1: Link partner is auto negotiation able 0: Link partner is not auto negotiation able Bit is set to 1 when device receives base page. It is cleared when Autoneg state goes to AN_ENABLE.

7.6.1.129 FX_LOCNP Register (Offset = C07h) [Reset = 2001h]

FX_LOCNP is shown in [Table 7-150](#).

Return to the [Summary Table](#).

Table 7-150. FX_LOCNP Register Field Descriptions

Bit	Field	Type	Reset	Description
15	NP_TX_NEXT_PAGE	R/W	0h	0: if last page 1: if there is more pages to transmit
14	RESERVED	R	0h	Reserved
13	NP_TX_MESSAGE_PAGE_MODE	R/W	1h	0: unformatted page 1: message page
12	NP_TX_ACK_2	R/W	0h	device has the ability to comply with the message 0: cannot comply with message. 1: comply with message.
11	NP_TX_TOGGLE	R	0h	0: previous value of the transmitted link codeword equalled logic one. 1: previous value of the transmitted link codeword equalled logic zero
10-0	NP_TX_MESSAGE_FIELD	R/W	1h	Message code field as defined in IEEE Annex 28C

7.6.1.130 FX_LPNP Register (Offset = C08h) [Reset = 0000h]

FX_LPNP is shown in [Table 7-151](#).

Return to the [Summary Table](#).

Table 7-151. FX_LPNP Register Field Descriptions

Bit	Field	Type	Reset	Description
15	LP_NP_NEXT_PAGE	R	0h	LP last page 0: if last page 1: if there is more pages to transmit
14	LP_NP_ACK	R	0h	Reserved
13	LP_NP_MESSAGE_PAGE_MODE	R	0h	LP message page mode 0: unformatted page 1: message page
12	LP_NP_ACK_2	R	0h	LP has the ability to comply with the message 0: cannot comply with message. 1: comply with message.

Table 7-151. FX_LPNP Register Field Descriptions (continued)

Bit	Field	Type	Reset	Description
11	LP_NP_TOGGLE	R	0h	LP Toggle bit 0: previous value of the transmitted link codeword equalled logic one. 1: previous value of the transmitted link codeword equalled logic zero
10-0	LP_NP_MESSAGE_FIEL D	R	0h	LP Message code field as defined in IEEE Annex 28C

7.6.1.131 CFG_FX_CTRL0 Register (Offset = C10h) [Reset = 0000h]

CFG_FX_CTRL0 is shown in [Table 7-152](#).

Return to the [Summary Table](#).

Table 7-152. CFG_FX_CTRL0 Register Field Descriptions

Bit	Field	Type	Reset	Description
15-10	RESERVED	R	0h	RESERVED
9	CFG_SDIN	R/W	0h	0h = Use Signal Detect Pin 1h = Signal Detect Pin is not used
8-0	RESERVED	R	0h	RESERVED

7.6.1.132 FX_INT_EN Register (Offset = C18h) [Reset = 03FFh]

FX_INT_EN is shown in [Table 7-153](#).

Return to the [Summary Table](#).

Table 7-153. FX_INT_EN Register Field Descriptions

Bit	Field	Type	Reset	Description
15-10	RESERVED	R	0h	Reserved
9	FEF_FAULT_EN	R/W	1h	FEF fault received interrupt enable 0h = Disable Interrupt 1h = Enable Interrupt
8	TX_FIFO_FULL_EN	R/W	1h	Fiber and SGMII Tx FIFO full interrupt enable 0h = Disable Interrupt 1h = Enable Interrupt
7	TX_FIFO_EMPTY_EN	R/W	1h	Fiber and SGMII Tx FIFO empty interrupt enable 0h = Disable Interrupt 1h = Enable Interrupt
6	RX_FIFO_FULL_EN	R/W	1h	Fiber and SGMII Rx FIFO full interrupt enable 0h = Disable Interrupt 1h = Enable Interrupt
5	RX_FIFO_EMPTY_EN	R/W	1h	Fiber and SGMII Rx FIFO empty interrupt enable 0h = Disable Interrupt 1h = Enable Interrupt
4	LINK_STS_CHANGE_EN	R/W	1h	Link Status Change Interrupt Enable 0h = Disable Interrupt 1h = Enable Interrupt
3	LP_FAULT_RX_EN	R/W	1h	Link Partner Remote Fault Interrupt Enable 0h = Disable Interrupt 1h = Enable Interrupt
2	PRI_RES_FAIL_EN	R/W	1h	Priority Resolution Fail Interrupt Enable 0h = Disable Interrupt 1h = Enable Interrupt
1	LP_NP_RX_EN	R/W	1h	Link Partner Next Page Received Interrupt Enable 0h = Disable Interrupt 1h = Enable Interrupt

Table 7-153. FX_INT_EN Register Field Descriptions (continued)

Bit	Field	Type	Reset	Description
0	LP_BP_RX_EN	R/W	1h	Link Partner Base Page Received Interrupt Enable 0h = Disable Interrupt 1h = Enable Interrupt

7.6.1.133 FX_INT_STS Register (Offset = C19h) [Reset = 0000h]

FX_INT_STS is shown in [Table 7-154](#).

Return to the [Summary Table](#).

Table 7-154. FX_INT_STS Register Field Descriptions

Bit	Field	Type	Reset	Description
15-10	RESERVED	R	0h	Reserved
9	FEF_FAULT	RC	0h	FEF fault received interrupt 0h = No Interrupt pending 1h = Interrupt pending, cleared on read
8	TX_FIFO_FULL	RC	0h	Fiber Tx FIFO full interrupt 0h = No Interrupt pending 1h = Interrupt pending, cleared on read
7	TX_FIFO_EMPTY	RC	0h	Fiber Tx FIFO empty interrupt 0h = No Interrupt pending 1h = Interrupt pending, cleared on read
6	RX_FIFO_FULL	RC	0h	Fiber Rx FIFO full interrupt 0h = No Interrupt pending 1h = Interrupt pending, cleared on read
5	RX_FIFO_EMPTY	RC	0h	Fiber Rx FIFO empty interrupt 0h = No Interrupt pending 1h = Interrupt pending, cleared on read
4	LINK_STS_CHANGE	RC	0h	Link Status Change Interrupt 0h = No Interrupt pending 1h = Interrupt pending, cleared on read
3	LP_FAULT_RX	RC	0h	Link Partner Remote Fault Interrupt 0h = No Interrupt pending 1h = Interrupt pending, cleared on read
2	PRI_RES_FAIL	RC	0h	Priority Resolution Fail Interrupt 0h = No Interrupt pending 1h = Interrupt pending, cleared on read
1	LP_NP_RX	RC	0h	Link Partner Next Page Received Interrupt 0h = No Interrupt pending 1h = Interrupt pending, cleared on read
0	LP_BP_RX	RC	0h	Link Partner Base Page Received Interrupt 0h = No Interrupt pending 1h = Interrupt pending, cleared on read

8 Application and Implementation

Note

Information in the following applications sections is not part of the TI component specification, and TI does not warrant its accuracy or completeness. TI's customers are responsible for determining suitability of components for their purposes, as well as validating and testing their design implementation to confirm system functionality.

8.1 Application Information

The DP83869HM is a 10/100/1000 Copper and Fiber Ethernet PHY. It supports connections to an Ethernet MAC through SGMII or RGMII. MII is also supported but only for 100M and 10M speeds. For MII to be operate correctly, 1000M advertisement should be disabled. SGMII is not available in Fiber Ethernet mode and Media Converter mode because the SGMII pins are multipurpose pins which carry Fiber Ethernet signals. Connections to the Ethernet media are made through the IEEE 802.3 defined Media Dependent Interface.

When using the device for Ethernet application, it is necessary to meet certain requirements for normal operation of the device. The following typical application and design requirements can be used for selecting appropriate component values for the DP83869.

8.2 Typical Applications

8.2.1 Copper Ethernet Typical Application

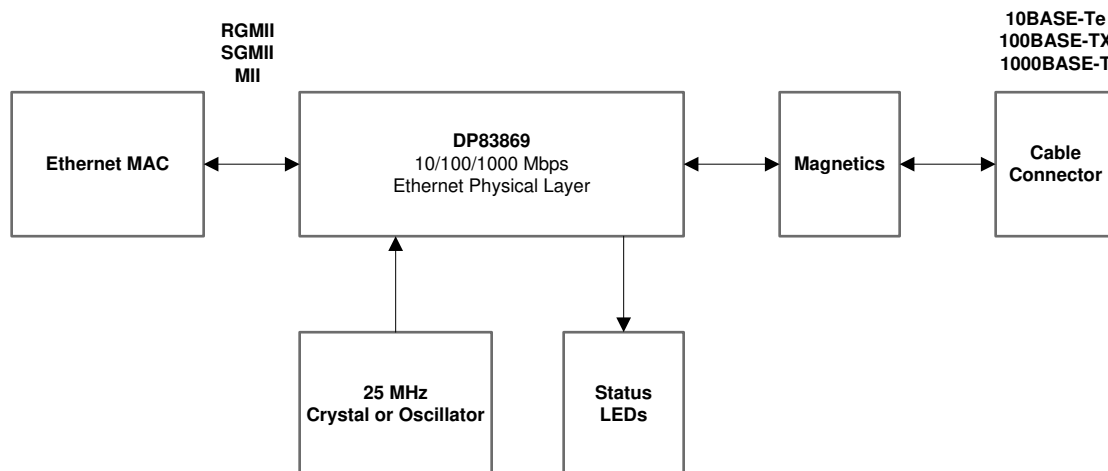

Figure 8-1. Typical Copper Ethernet Application

8.2.1.1 Design Requirements

The design requirements for the DP83869HM are:

- VDDA2P5 = 2.5V
- VDD1P1 = 1.1V
- VDDIO = 3.3V, 2.5V, or 1.8V
- VDDA1P8_x = 1.8V (optional)
- Clock Input = 25MHz

8.2.1.2 Detailed Design Procedure

8.2.1.2.1 Clock Input

Input reference clock requirements are same in all functional modes.

8.2.1.2.1.1 Crystal Recommendations

A 25MHz, parallel, 15pF to 40pF load crystal resonator must be used if a crystal source is desired. [Figure 8-2](#) shows a typical connection for a crystal resonator circuit. The load capacitor values vary with the crystal vendors. Check with the vendor for the recommended loads.

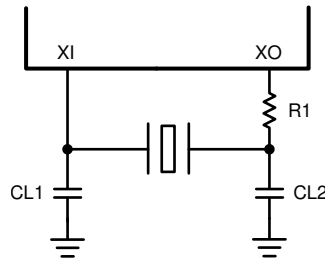

Figure 8-2. Crystal Oscillator Circuit

As a starting point for evaluating the oscillator performance, the value of CL1 and CL2 must each be equal to 2x the specified load capacitance from the crystal vendor’s data sheet. For example, if the specified load capacitance of the crystal is 10pF, set CL1 = CL2 = 20pF. CL1, CL2 value may need to be adjusted based on the parasitic capacitance. Depending on the crystal drive level, R1 may or may not be needed.

Specification for 25MHz crystal are listed in [Table 8-1](#) .

Table 8-1. 25MHz Crystal Specifications

PARAMETER	TEST CONDITION	MIN	TYP	MAX	UNIT
Frequency			25		MHz
Frequency Tolerance	Including Operational Temperature, Aging, and Other Factors			±100	ppm
Load Capacitance		15		40	pF
ESR				50	ohm

8.2.1.2.1.2 External Clock Source Recommendation

If an external clock oscillator is used, then it must be directly connected to XI. XO should be left floating.

The CMOS 25MHz oscillator specifications are listed in [Table 8-2](#) .

Table 8-2. 25MHz Oscillator Specifications

PARAMETER	TEST CONDITION	MIN	TYP	MAX	UNIT
Frequency			25		MHz
Frequency Tolerance	Operational Temperature, 1 Year Aging			±100	ppm
Rise / Fall Time	20% - 80%			5	ns
Symmetry	Duty Cycle	40%		60%	

8.2.1.2.2 Magnetics Requirements

In applications where copper Ethernet interface is used, magnetic isolation is required. Magnetics can be discrete or integrated in the Ethernet cable connector. The DP83869HM will operate with discrete and integrate magnetics if they meet the electrical specifications listed in [Table 8-3](#).

Table 8-3. Magnetics Electrical Specification

PARAMETER	TEST CONDITIONS	TYP	UNIT
Turns Ratio	±2% Tolerance	1:1	-
Insertion Loss	1-100MHz	-1	dB
Return Loss	1-30MHz	-16	dB
	30-60MHz	-12	dB
	60-80MHz	-10	dB
Differential to Common Mode Rejection	1-50MHz	-30	dB
	60-150MHz	-20	dB
Crosstalk	30MHz	-35	dB
	60MHz	-30	dB
Open Circuit Inductance	8mA DC Bias	350	µH
Isolation	HPOT	1500	Vrms

8.2.1.2.2.1 Magnetics Connection

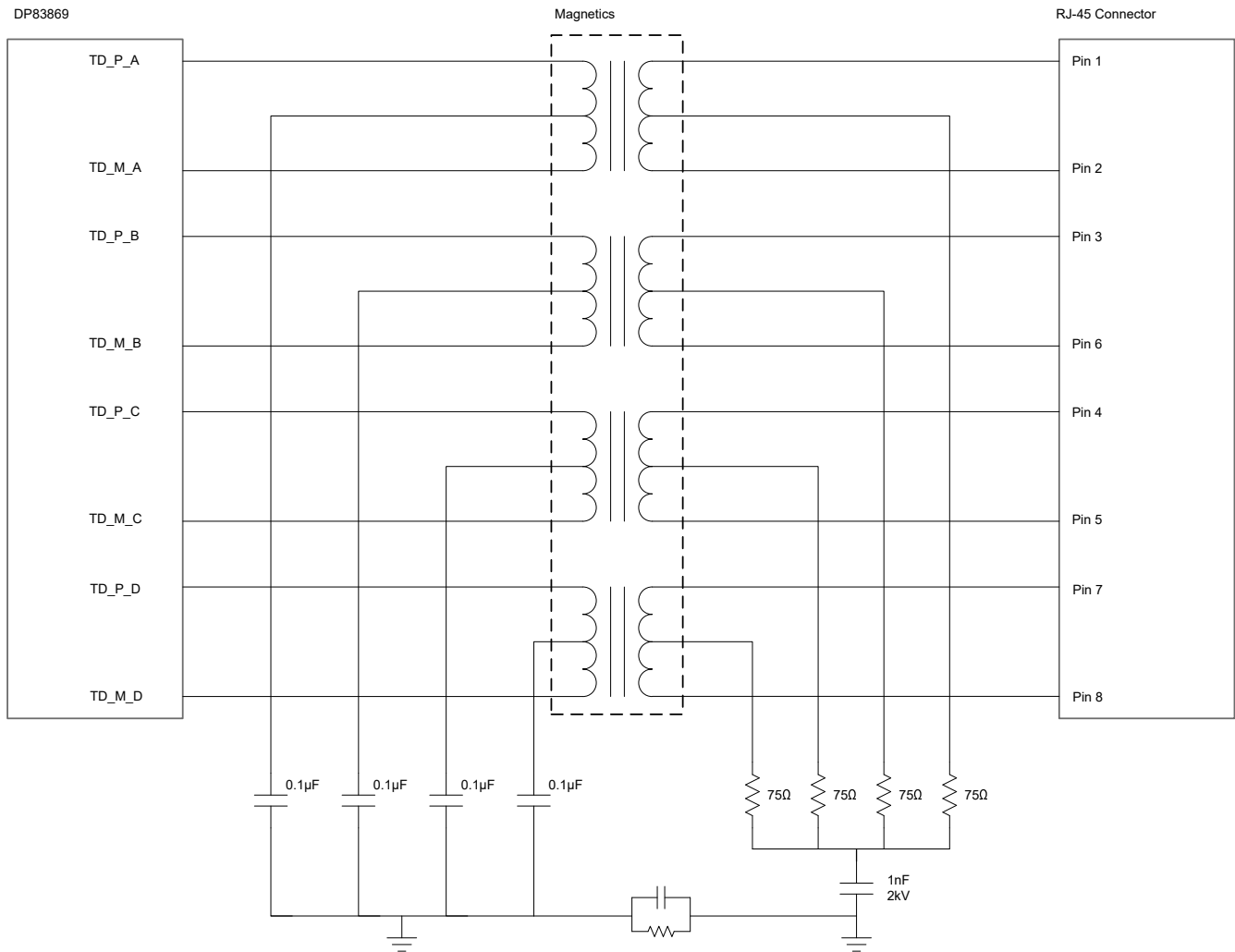

- A. Each center tap on the side connected to the PHY, must be isolated from one another and connected to ground via a decoupling capacitor (0.1µF recommended).
- B. Discrete transformer is recommended for better EMC/EMI performance. Pulse Electronics part, HX5008FNL is recommended for discrete magnetics.
- C. Only Channels A&B are required for 100Mbps/10Mbps communication
- D. R//C ground isolation circuit is recommended for EMI purposes. Please refer to [DP83869 Schematic Checklist](#) for recommended values

Figure 8-3. PHY to RJ45 and Magnetics

8.2.1.3 Application Curves

For expected MDI signal, see [Table 8-4](#).

Table 8-4. Table of Graphs

NAME	FIGURE
1000Base-T Signal	Figure 6-9
100Base-TX Signal	Figure 6-10
10Base-Te Link Pulse	Figure 6-11
Auto-Negotiation FLP	Figure 6-12

8.2.2 Fiber Ethernet Typical Ethernet

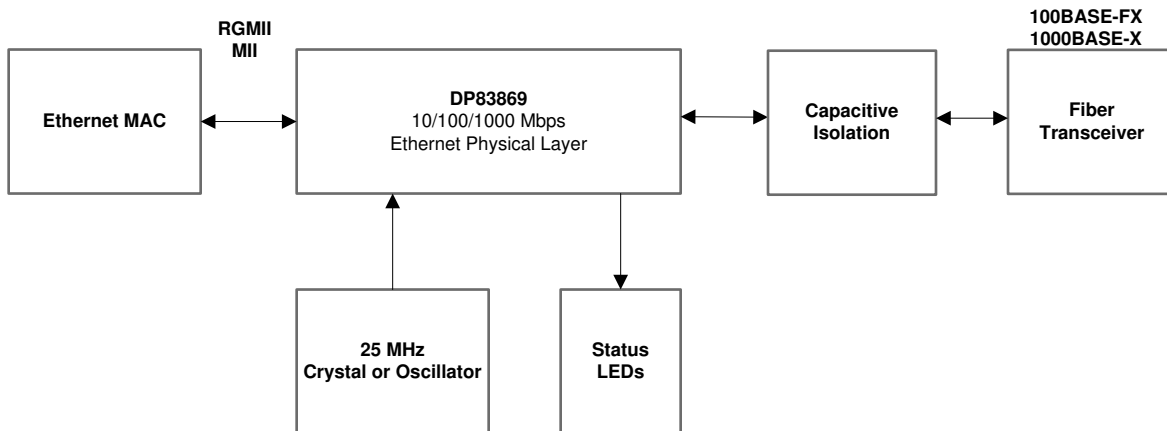

Figure 8-4. Typical Fiber Ethernet Application

8.2.2.1 Design Requirements

The design requirements for the DP83869HM are:

- VDDA2P5 = 2.5V
- VDD1P1 = 1.1V
- VDDIO = 3.3V, 2.5V, or 1.8V
- VDDA1P8_x = 1.8V (optional)
- Clock Input = 25MHz

8.2.2.2 Detailed Design Procedure

See [Section 8.2.1.2](#) for more information.

8.2.2.2.1 Transceiver Connections

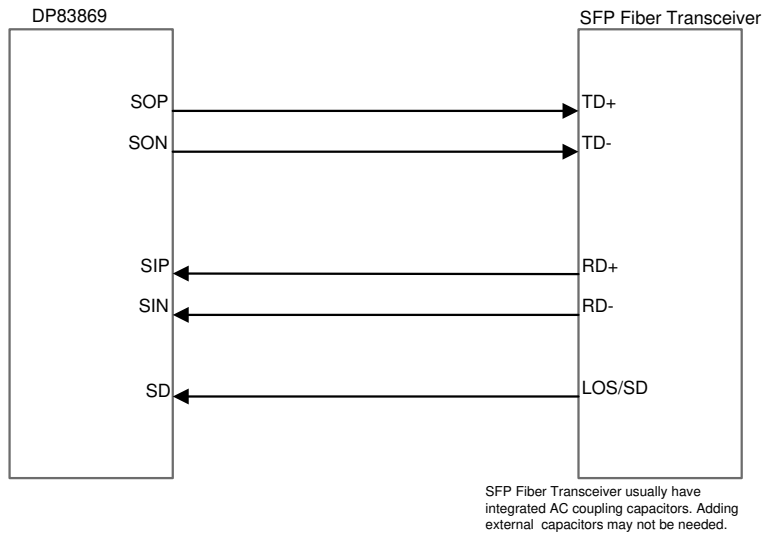

Figure 8-5. PHY to Fiber Transceiver Connections

8.2.2.3 Application Curves

For expected MDI signal, see [Table 8-4](#) in the [Section 8.2.1.3](#) section.

8.3 Power Supply Recommendations

The DP83869HM is capable of operating with as few as two or three supplies. The I/O power supply can also be operated independently of the main device power supplies to provide flexibility for the MAC interface. There are two possible supply configuration that can be used: Two-supply and Three-supply. In Two-supply Configuration, no power rail is connected to VDDA1P8_x pins (pin 13, 48). When unused, pin 13 and 48 should be left floating with no components attached to them.

8.3.1 Two-Supply Configuration

[Figure 8-6](#) shows the connection diagram for a two-supply configuration.

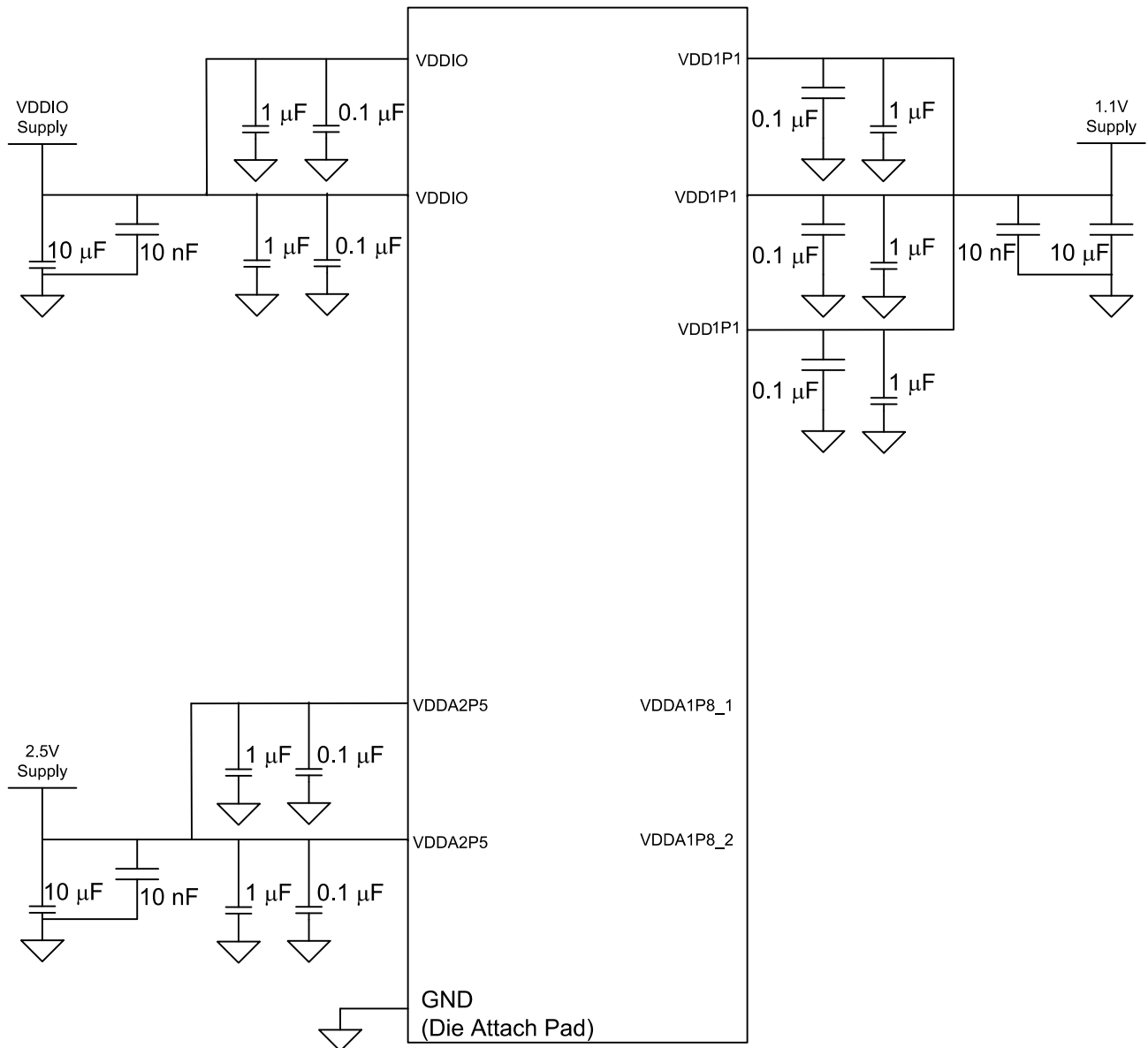

Figure 8-6. Two-Supply Configuration

For a two-supply configuration, both VDDA1P8 pins must be left unconnected.

Place 1µF and 0.1µF decoupling capacitors as close as possible to component VDD pins, placing the 0.1µF capacitor closest to the pin.

For two-supply configuration, the recommendation is to power all supplies together. If that is not possible, then the following power sequencing must be used.

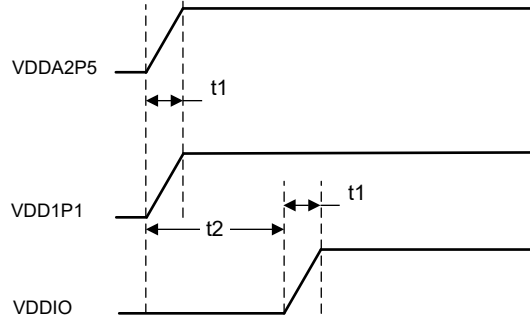

Figure 8-7. Two-Supply Sequence Diagram

Table 8-5. Two-Supply Sequence

PARAMETER		TEST CONDITIONS	MIN	NOM	MAX	UNIT
t1	Supply ramp time	Applicable to all supplies	0.5		100	ms
t2	Time instance at which VDDIO starts up	Measured with respect to start of VDDA2P5 and VDD1P1			50	ms

8.3.2 Three-Supply Configuration

Figure 8-8 shows the connection diagram for the three-supply configuration.

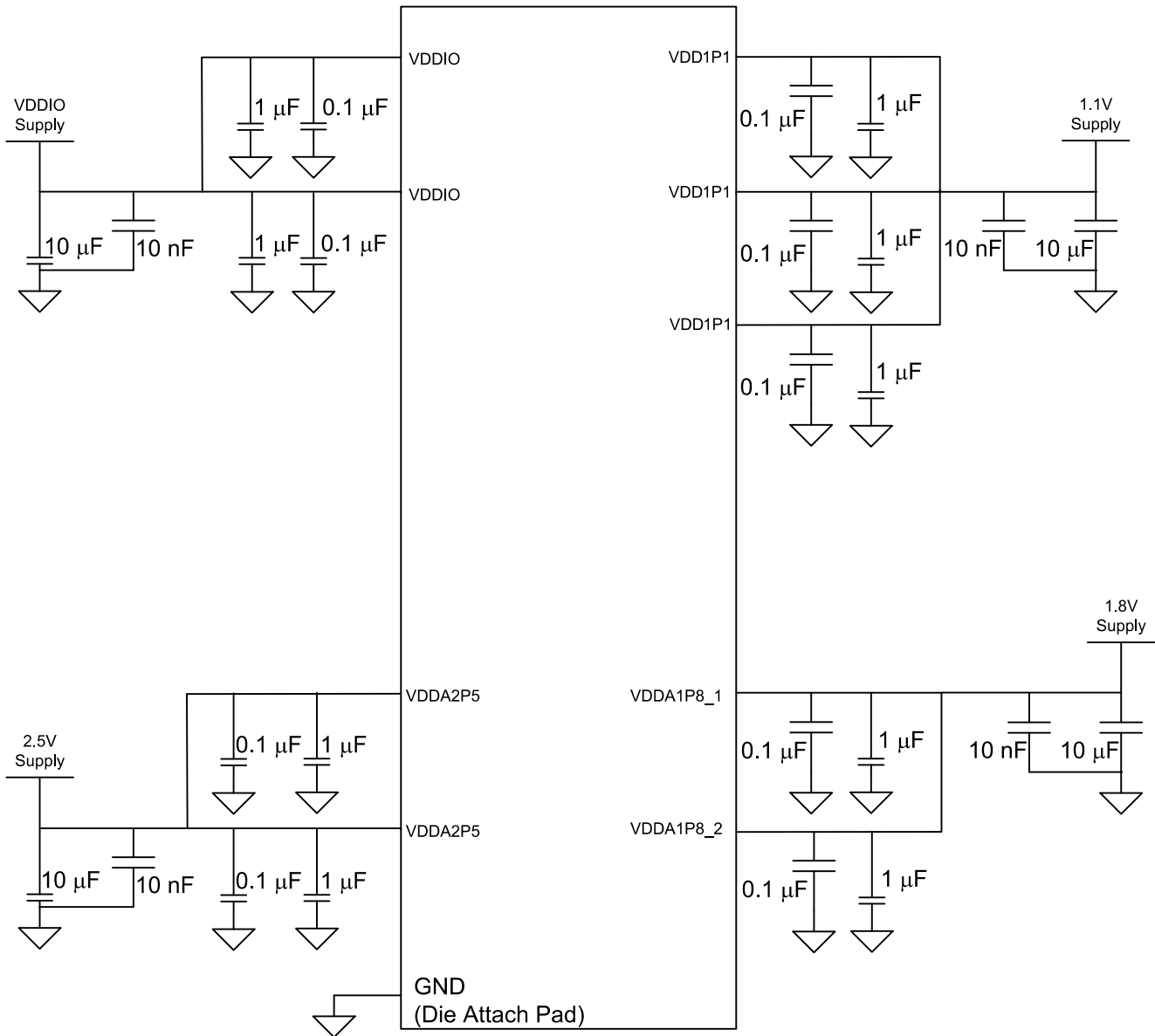

Figure 8-8. Three-Supply Configuration

Place 1 μF and 0.1 μF decoupling capacitors as close as possible to component VDD pins, placing the 0.1 μF capacitor closest to the pin.

For three-supply configuration, the recommendation is to power all supplies together. If that is not possible, then the following power sequencing must be used.

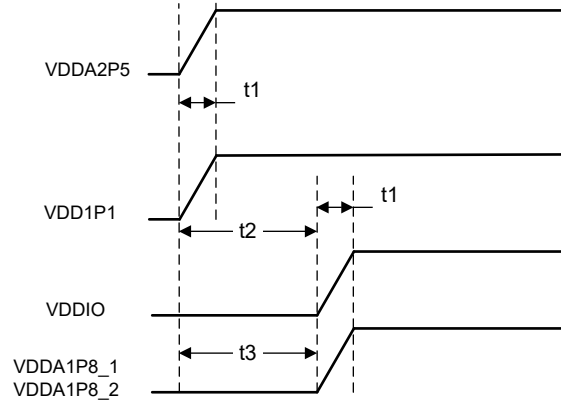

Figure 8-9. Three-Supply Sequence Diagram

Table 8-6. Three-Supply Sequence

PARAMETER	TEST CONDITIONS	MIN	NOM	MAX	UNIT
t1	Supply ramp time	0.5		100	ms
t2	Time instance at which VDDIO starts up	0		50	ms
t3	Time instance at which VDDA1P8_x starts up	0		50	ms

8.4 Layout

8.4.1 Layout Guidelines

8.4.1.1 Signal Traces

PCB traces are lossy and long traces can degrade the signal quality. Traces must be kept short as possible. Unless mentioned otherwise, all signal traces should be 50Ω, single-ended impedance. Differential traces should be 50Ω, single-ended and 100Ω differential. Take care that the impedance is constant throughout. Impedance discontinuities cause reflections leading to EMI and signal integrity problems. Stubs must be avoided on all signal traces, especially the differential signal pairs. See [Figure 8-10](#).

Within the differential pairs, the trace lengths must run parallel to each other and matched in length. Matched lengths minimize delay differences, avoiding an increase in common-mode noise and increased EMI.

Length matching is also important on MAC interface. All Transmit signal trace lengths must match to each other and all Receive signal trace lengths must match to each other. When using 1G transmission speeds, the tolerance for length matching is 50 mils. When using 100/10M, the tolerance for length matching is 100 mils.

Ideally, there should be no crossover or via on the signal paths. Vias present impedance discontinuities and should be minimized. Route an entire trace pair on a single layer if possible.

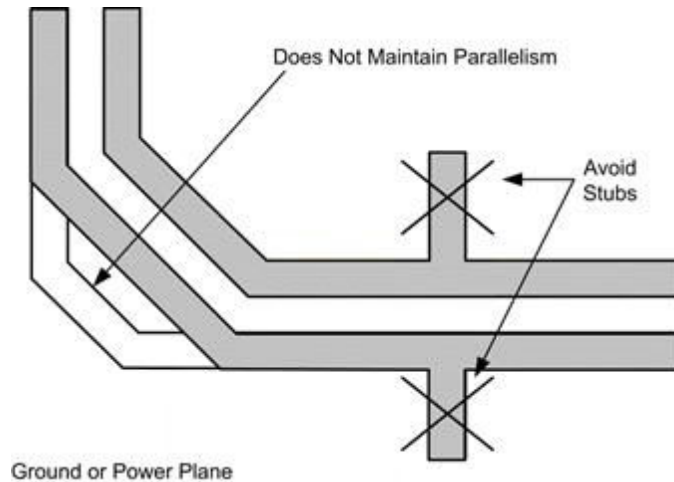

Figure 8-10. Avoiding Stubs in a Differential Signal Pair

Signals on different layers should not cross each other without at least one return path plane between them.

Coupling between traces is also an important factor. Unwanted coupling can cause cross talk problems. Differential pairs on the other hand, should have a constant coupling distance between them.

For convenience and efficient layout process, start by routing the critical signals first.

8.4.1.1.1 MAC Interface Layout Guidelines

The Media Independent Interface (SGMII / RGMII) connects the DP83869 to the Media Access Controller (MAC). The MAC may in fact be a discrete device, integrated into a microprocessor, CPU, or FPGA.

8.4.1.1.1.1 SGMII Layout Guidelines

- All SGMII connections must be AC-coupled through an 0.1 μ F capacitor. Series capacitors must be 0.1 μ F and the size must be 0402 or smaller.
- SGMII signals are differential signals.
- Traces must be routed with 100 Ω differential impedance.
- Skew matching within a pair must be less than 5pS, which correlates to 30 mil for standard FR4.
- There is no requirement to match the TX pair to the RX pair.
- SGMII signals must be routed on the same layer.
- Pairs must be referenced to parallel ground plane.
- When operating in 6-wire mode, the RX pair must match the Clock pair to within 5pS, which correlates to 30 mil for standard FR4.

8.4.1.1.1.2 RGMII Layout Guidelines

- RGMII signals are single-ended signals.
- Traces must be routed with impedance of 50 Ω to ground.
- Skew between TXD[3:0] lines must be less than 11ps, which correlates to 60 mil for standard FR4.
- Skew between RXD[3:0] lines must be less than 11ps, which correlates to 60 mil for standard FR4.
- Keep trace lengths as short as possible, Traces less than 2 inches is recommended with less than 6 inches as maximum length.
- Configurable clock skew for GTX_CLK and RX_CLK.
 - Clock skew for RX and TX paths can be optimized independently.
 - Clock skew is adjustable in 0.25ns increments (through register).

8.4.1.1.2 MDI Layout Guidelines

The Media Dependent Interface (MDI) connects the DP83869 to the transformer and the Ethernet network.

- MDI traces must be 50 Ω to ground and 100 Ω differential controlled impedance.
- Route MDI traces to transformer on the same layer.

- Use a metal shielded RJ-45 connector, and connect the shield to chassis ground.
- Use magnetics with integrated common-mode choking devices.
- Void supplies and ground beneath magnetics.
- Do not overlap the circuit and chassis ground planes, keep them isolated. Instead, make chassis ground an isolated island and make a void between the chassis and circuit ground. Connecting circuit and chassis planes using a size 1206 resistor and capacitor on either side of the connector is a good practice.

8.4.1.2 Return Path

A general best practice is to have a solid return path beneath all signal traces. This return path can be a continuous ground or DC power plane. Reducing the width of the return path width can potentially affect the impedance of the signal trace. This effect is more prominent when the width of the return path is comparable to the width of the signal trace. Breaks in return path beneath the signal traces should be avoided at all cost. A signal crossing a plane split may cause unpredictable return path currents and would likely impact signal quality as well, potentially creating EMI problems. See [Figure 8-11](#).

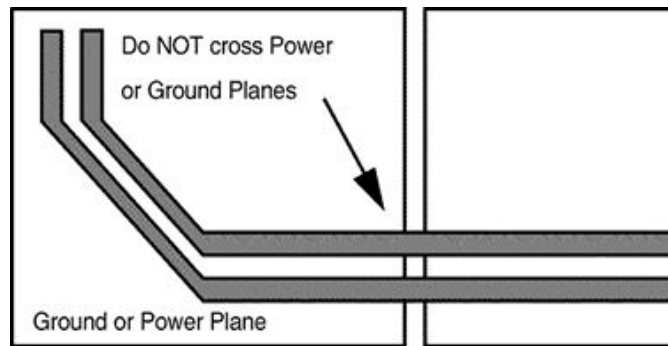

Figure 8-11. Differential Signal Pair-Plane Crossing

8.4.1.3 Transformer Layout

There should be no metal layer running beneath the transformer. Transformers can inject noise in metal beneath them which can affect the performance of the system.

8.4.1.4 Metal Pour

All metal pours which are not signals or power should be tied to ground. There should be no floating metal on the system. There should be no metal between the differential traces.

8.4.1.5 PCB Layer Stacking

To meet signal integrity and performance requirements, at minimum a 4-layer PCB should be used. However a 6-layer board is recommended. See [Figure 8-12](#) for the recommended layer stack ups for 4, 6, and 8-layer boards. These are recommendations not requirements, other configurations can be used as per system requirements.

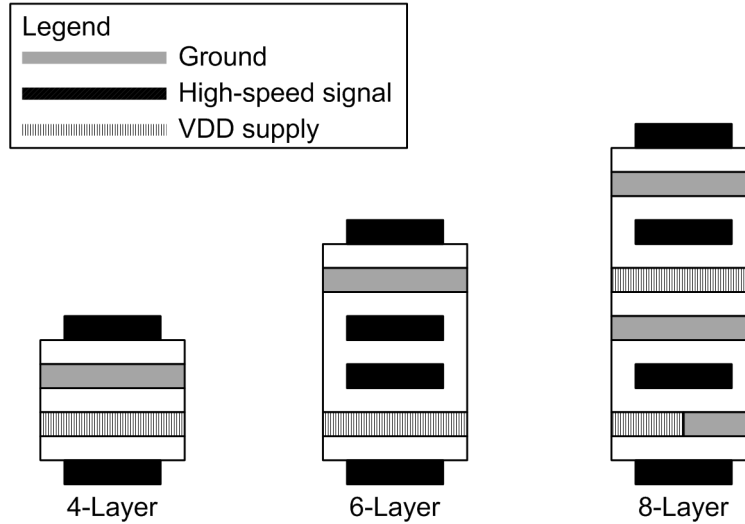

Figure 8-12. Recommended Layer Stack-Up

Within a PCB, it may be desirable to run traces using different methods, microstrip vs. stripline, depending on the location of the signal on the PCB. For example, it may be desirable to change layer stacking where an isolated chassis ground plane is used. [Figure 8-13](#) shows alternative PCB stacking options.

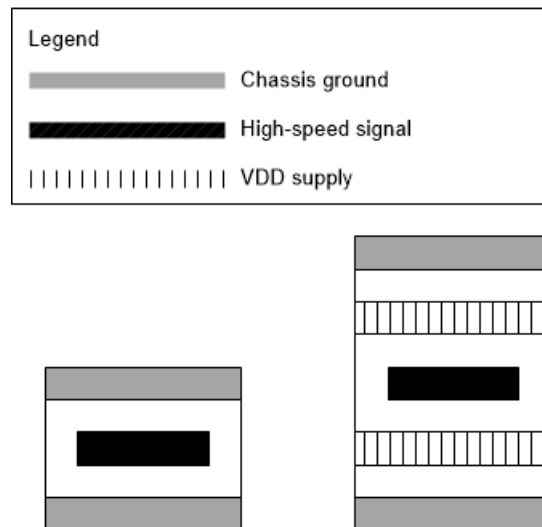

Figure 8-13. Alternative Layer Stack-Up

8.4.2 Layout Example

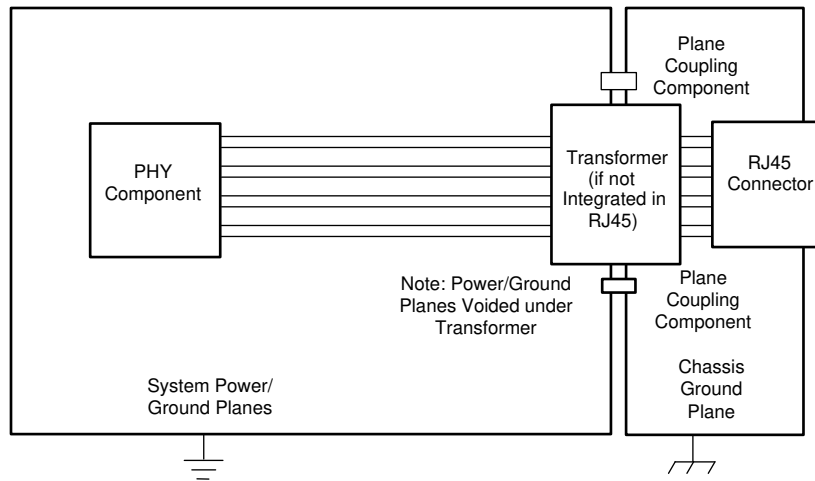

Figure 8-14. Copper Ethernet Layout Example

9 Device and Documentation Support

9.1 Documentation Support

9.1.1 Related Documentation

For related documentation, see the following:

Texas Instruments, [DP83869 100Base-X Link Detection application note](#)

9.2 Receiving Notification of Documentation Updates

To receive notification of documentation updates, navigate to the device product folder on ti.com. In the upper right corner, click on *Alert me* to register and receive a weekly digest of any product information that has changed. For change details, review the revision history included in any revised document.

9.3 Support Resources

[TI E2E™ support forums](#) are an engineer's go-to source for fast, verified answers and design help — straight from the experts. Search existing answers or ask your own question to get the quick design help you need.

Linked content is provided "AS IS" by the respective contributors. They do not constitute TI specifications and do not necessarily reflect TI's views; see TI's [Terms of Use](#).

9.4 Trademarks

TI E2E™ is a trademark of Texas Instruments.

All trademarks are the property of their respective owners.

9.5 Electrostatic Discharge Caution



This integrated circuit can be damaged by ESD. Texas Instruments recommends that all integrated circuits be handled with appropriate precautions. Failure to observe proper handling and installation procedures can cause damage.

ESD damage can range from subtle performance degradation to complete device failure. Precision integrated circuits may be more susceptible to damage because very small parametric changes could cause the device not to meet its published specifications.

9.6 Glossary

[TI Glossary](#) This glossary lists and explains terms, acronyms, and definitions.

10 Revision History

NOTE: Page numbers for previous revisions may differ from page numbers in the current version.

Changes from Revision B (December 2022) to Revision C (April 2024)	Page
• RESET_N Pin State in IEEE PWDN corrected from PD to PU.....	4
• Added Junction Temperature Spec.....	10
• Magic Packet Detection Registers Table added.....	27
• Added BIST Configuration example.....	31
• More detailed steps to enable MII mode of operation added.....	38
• Extended Register Space section formatted more clearly.....	43
• Corrected typo 100Base-T to 100Base-TX.....	48
• Corrected table functions.....	49
• Added IPG Control Registers (0x7B-0x7C), SFD Registers (0xE9, 0x55), PRBS Config Registers (0x71, 0x72, 0x1A8, 0x1A9), CLKOUT Config Reg (0xC6, needed before writing to 0x170), and WoL Registers (0x134-0x15F).....	53
• Added RC ground isolation circuit to Magnetics connection figure.....	107
• Removed mention of SUPPLYMODE_SEL, pin 23, which doesn't exist on this part.....	109
• Removed line mentioning SUPPLYMODE_SEL, does not exist on this device.....	112

Changes from Revision A (September 2018) to Revision B (December 2022)	Page
• Changed fiber compliance to current Specification	1
• Updated the numbering format for tables, figures, and cross-references throughout the document.....	1
• Deleted leading 0 from all register, read, and write statements	27
• Deleted 1000Base-X fiber application clarification, bug has been fixed	35
• Changed bridge mode image and description to clarify TX and RX pin behavior.....	40
• Changed description of Media Converter mode to support Unmanaged Media Converter mode in response to bug fix	41
• Changed register read and writes to correct values with comments	41
• Changed number of PHYs and size of PHY address.....	42
• Added clarification for Auto-Negotiation setting.....	50
• Changed strapping modes in the figure and description to correct values.....	50
• Changed Table 8-1 to clarify Frequency Tolerance	105
• Changed to Table 8-2 clarify Frequency Tolerance	106
• Changed the two-supply config figure to the correct number of pins for VDDIO and VDD1P1, also changed the pin name from VDDA1P1 to VDD1P1.....	109
• Changed the three-supply config figure to the correct number of pins for VDDIO and VDD1P1, also changed the pin name from VDDA1P1 to VDD1P1.....	112

11 Mechanical, Packaging, and Orderable Information

The following pages include mechanical, packaging, and orderable information. This information is the most current data available for the designated devices. This data is subject to change without notice and revision of this document. For browser-based versions of this data sheet, refer to the left-hand navigation.

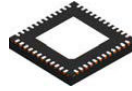

RGZ0048B

PACKAGE OUTLINE

VQFN - 1 mm max height

PLASTIC QUAD FLATPACK - NO LEAD

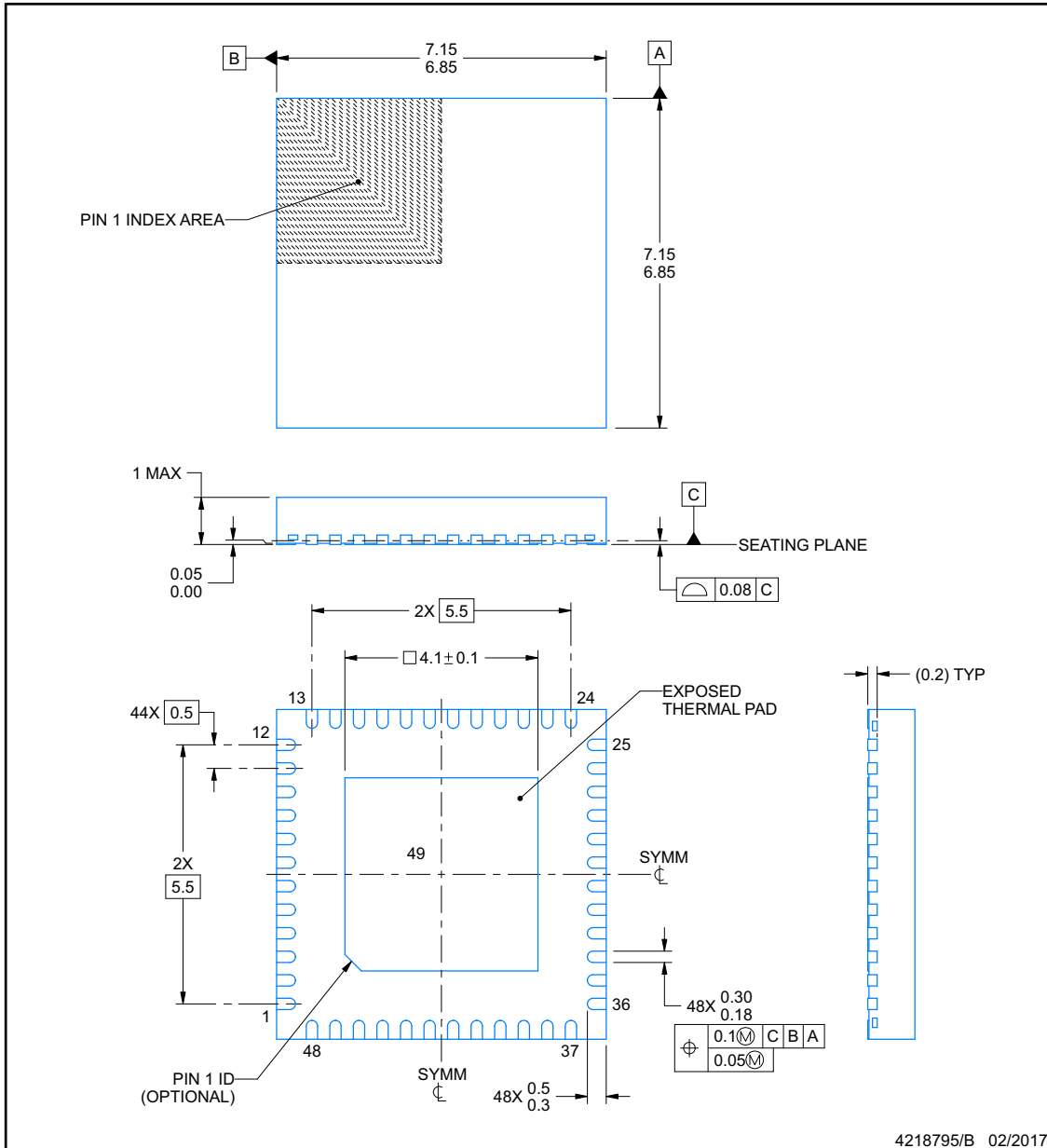

NOTES:

1. All linear dimensions are in millimeters. Any dimensions in parenthesis are for reference only. Dimensioning and tolerancing per ASME Y14.5M.
2. This drawing is subject to change without notice.
3. The package thermal pad must be soldered to the printed circuit board for thermal and mechanical performance.

EXAMPLE BOARD LAYOUT

RGZ0048B

VQFN - 1 mm max height

PLASTIC QUAD FLATPACK - NO LEAD

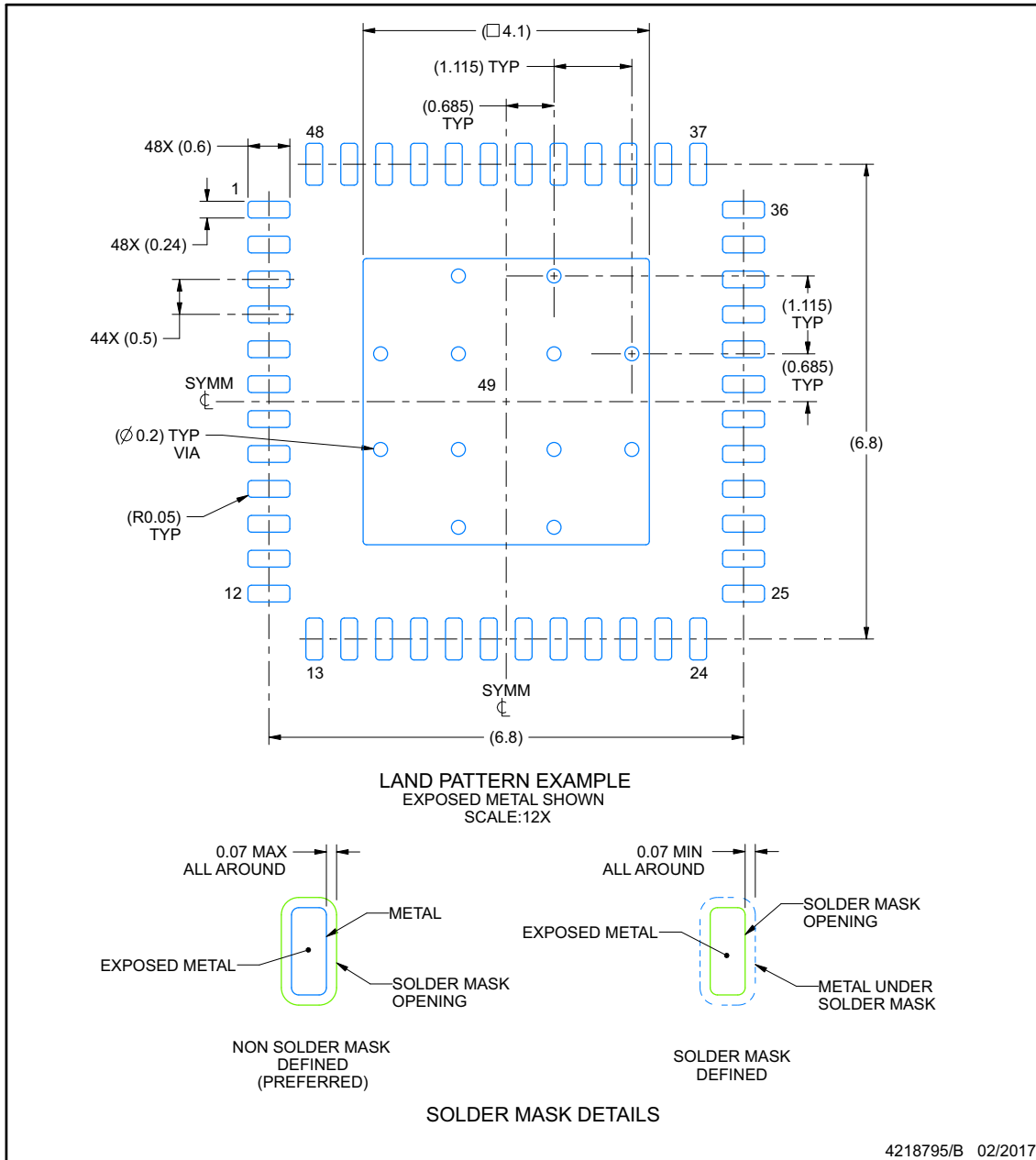

NOTES: (continued)

- This package is designed to be soldered to a thermal pad on the board. For more information, see Texas Instruments literature number SLUA271 (www.ti.com/lit/slua271).
- Vias are optional depending on application, refer to device data sheet. If any vias are implemented, refer to their locations shown on this view. It is recommended that vias under paste be filled, plugged or tented.

EXAMPLE STENCIL DESIGN

RGZ0048B

VQFN - 1 mm max height

PLASTIC QUAD FLATPACK - NO LEAD

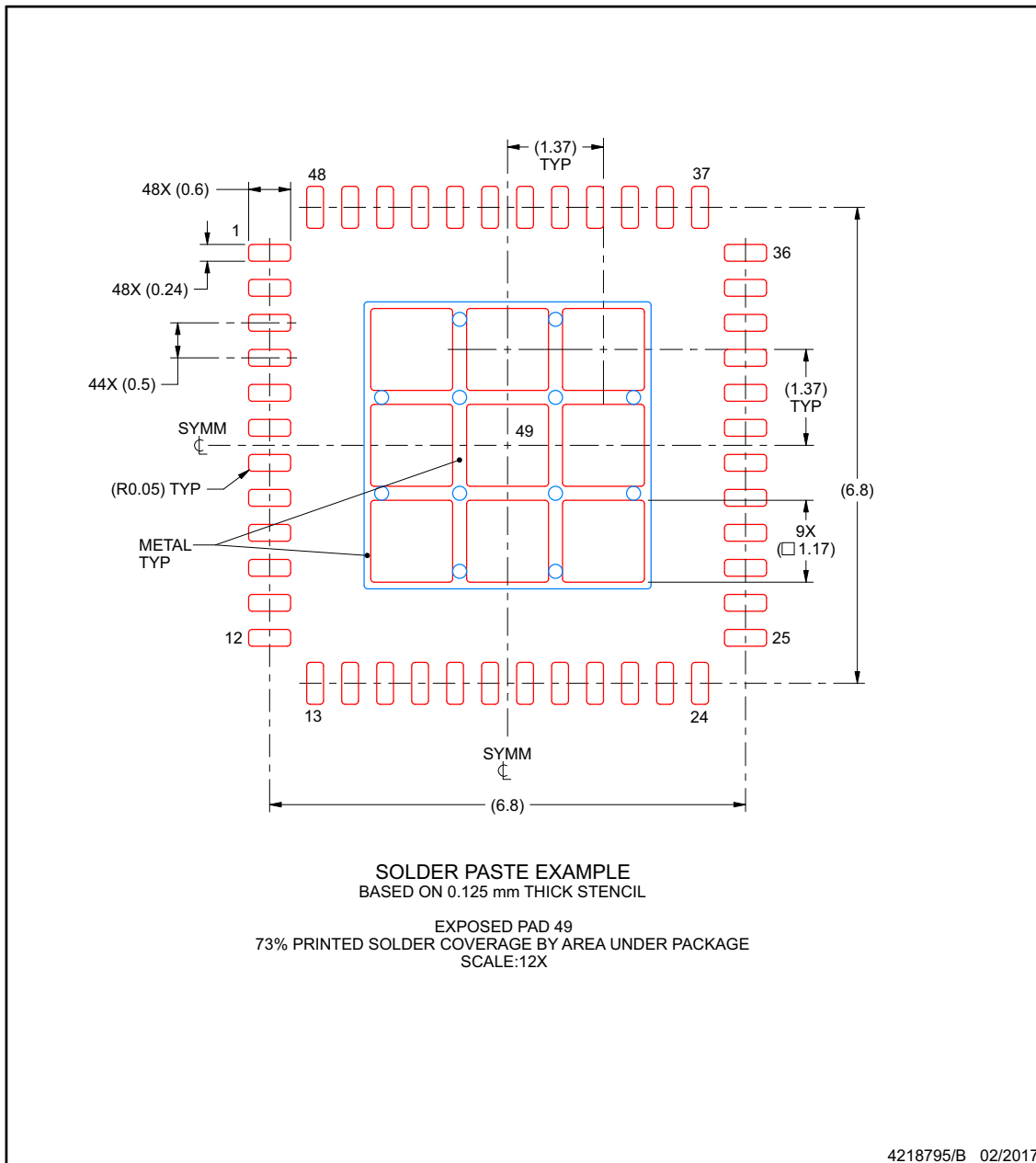

NOTES: (continued)

6. Laser cutting apertures with trapezoidal walls and rounded corners may offer better paste release. IPC-7525 may have alternate design recommendations.

PACKAGING INFORMATION

Orderable Device	Status (1)	Package Type	Package Drawing	Pins	Package Qty	Eco Plan (2)	Lead finish/ Ball material (6)	MSL Peak Temp (3)	Op Temp (°C)	Device Marking (4/5)	Samples
DP83869HMRGZR	ACTIVE	VQFN	RGZ	48	2000	RoHS & Green	Call TI NIPDAUAG	Level-2-260C-1 YEAR	-40 to 125	DP83869HM	Samples
DP83869HMRGZT	ACTIVE	VQFN	RGZ	48	250	RoHS & Green	NIPDAUAG	Level-2-260C-1 YEAR	-40 to 125	DP83869HM	Samples

(1) The marketing status values are defined as follows:

ACTIVE: Product device recommended for new designs.

LIFEBUY: TI has announced that the device will be discontinued, and a lifetime-buy period is in effect.

NRND: Not recommended for new designs. Device is in production to support existing customers, but TI does not recommend using this part in a new design.

PREVIEW: Device has been announced but is not in production. Samples may or may not be available.

OBSOLETE: TI has discontinued the production of the device.

(2) **RoHS:** TI defines "RoHS" to mean semiconductor products that are compliant with the current EU RoHS requirements for all 10 RoHS substances, including the requirement that RoHS substance do not exceed 0.1% by weight in homogeneous materials. Where designed to be soldered at high temperatures, "RoHS" products are suitable for use in specified lead-free processes. TI may reference these types of products as "Pb-Free".

RoHS Exempt: TI defines "RoHS Exempt" to mean products that contain lead but are compliant with EU RoHS pursuant to a specific EU RoHS exemption.

Green: TI defines "Green" to mean the content of Chlorine (Cl) and Bromine (Br) based flame retardants meet JS709B low halogen requirements of <=1000ppm threshold. Antimony trioxide based flame retardants must also meet the <=1000ppm threshold requirement.

(3) MSL, Peak Temp. - The Moisture Sensitivity Level rating according to the JEDEC industry standard classifications, and peak solder temperature.

(4) There may be additional marking, which relates to the logo, the lot trace code information, or the environmental category on the device.

(5) Multiple Device Markings will be inside parentheses. Only one Device Marking contained in parentheses and separated by a "~" will appear on a device. If a line is indented then it is a continuation of the previous line and the two combined represent the entire Device Marking for that device.

(6) Lead finish/Ball material - Orderable Devices may have multiple material finish options. Finish options are separated by a vertical ruled line. Lead finish/Ball material values may wrap to two lines if the finish value exceeds the maximum column width.

Important Information and Disclaimer:The information provided on this page represents TI's knowledge and belief as of the date that it is provided. TI bases its knowledge and belief on information provided by third parties, and makes no representation or warranty as to the accuracy of such information. Efforts are underway to better integrate information from third parties. TI has taken and continues to take reasonable steps to provide representative and accurate information but may not have conducted destructive testing or chemical analysis on incoming materials and chemicals. TI and TI suppliers consider certain information to be proprietary, and thus CAS numbers and other limited information may not be available for release.

In no event shall TI's liability arising out of such information exceed the total purchase price of the TI part(s) at issue in this document sold by TI to Customer on an annual basis.

TAPE AND REEL INFORMATION

QUADRANT ASSIGNMENTS FOR PIN 1 ORIENTATION IN TAPE

*All dimensions are nominal

Device	Package Type	Package Drawing	Pins	SPQ	Reel Diameter (mm)	Reel Width W1 (mm)	A0 (mm)	B0 (mm)	K0 (mm)	P1 (mm)	W (mm)	Pin1 Quadrant
DP83869HMRGZR	VQFN	RGZ	48	2000	330.0	16.4	7.3	7.3	1.1	12.0	16.0	Q2
DP83869HMRGZT	VQFN	RGZ	48	250	180.0	16.4	7.3	7.3	1.1	12.0	16.0	Q2

TAPE AND REEL BOX DIMENSIONS

*All dimensions are nominal

Device	Package Type	Package Drawing	Pins	SPQ	Length (mm)	Width (mm)	Height (mm)
DP83869HMRGZR	VQFN	RGZ	48	2000	367.0	367.0	38.0
DP83869HMRGZT	VQFN	RGZ	48	250	210.0	185.0	35.0

GENERIC PACKAGE VIEW

RGZ 48

VQFN - 1 mm max height

7 x 7, 0.5 mm pitch

PLASTIC QUADFLAT PACK- NO LEAD

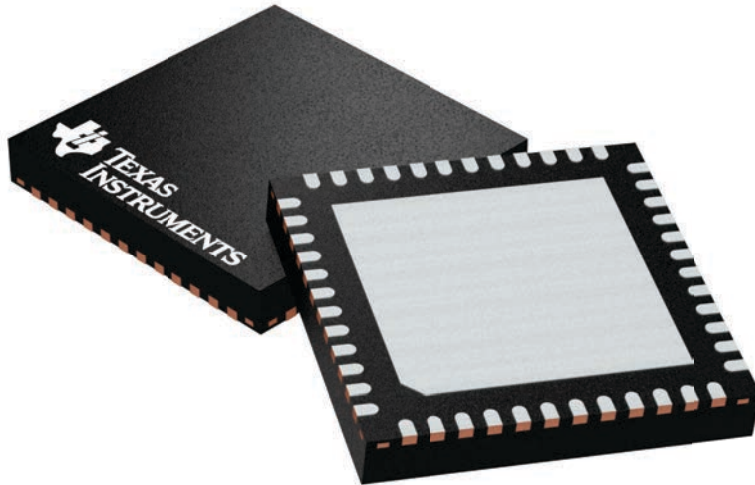

Images above are just a representation of the package family, actual package may vary.
Refer to the product data sheet for package details.

4224671/A

IMPORTANT NOTICE AND DISCLAIMER

TI PROVIDES TECHNICAL AND RELIABILITY DATA (INCLUDING DATA SHEETS), DESIGN RESOURCES (INCLUDING REFERENCE DESIGNS), APPLICATION OR OTHER DESIGN ADVICE, WEB TOOLS, SAFETY INFORMATION, AND OTHER RESOURCES "AS IS" AND WITH ALL FAULTS, AND DISCLAIMS ALL WARRANTIES, EXPRESS AND IMPLIED, INCLUDING WITHOUT LIMITATION ANY IMPLIED WARRANTIES OF MERCHANTABILITY, FITNESS FOR A PARTICULAR PURPOSE OR NON-INFRINGEMENT OF THIRD PARTY INTELLECTUAL PROPERTY RIGHTS.

These resources are intended for skilled developers designing with TI products. You are solely responsible for (1) selecting the appropriate TI products for your application, (2) designing, validating and testing your application, and (3) ensuring your application meets applicable standards, and any other safety, security, regulatory or other requirements.

These resources are subject to change without notice. TI grants you permission to use these resources only for development of an application that uses the TI products described in the resource. Other reproduction and display of these resources is prohibited. No license is granted to any other TI intellectual property right or to any third party intellectual property right. TI disclaims responsibility for, and you will fully indemnify TI and its representatives against, any claims, damages, costs, losses, and liabilities arising out of your use of these resources.

TI's products are provided subject to [TI's Terms of Sale](#) or other applicable terms available either on [ti.com](https://www.ti.com) or provided in conjunction with such TI products. TI's provision of these resources does not expand or otherwise alter TI's applicable warranties or warranty disclaimers for TI products.

TI objects to and rejects any additional or different terms you may have proposed.

Mailing Address: Texas Instruments, Post Office Box 655303, Dallas, Texas 75265
Copyright © 2024, Texas Instruments Incorporated