

DS560DF810 56 Gbps Multi-Rate 8-Channel Retimer with Crosspoint

1 Features

- channel multi-protocol retimer with integrated signal conditioning
- All channels lock independently to both PAM4 and NRZ data rates from 19.6 to 28.9 GBd (including div-by-2 and div-by-4 sub-rates)
- Suitable for up to CEI-56G, Ethernet™ (400 GbE), fibre channel (64GFC), InfiniBand™ (HDR), and CPRI/eCPRI PCB, copper cable, and optical applications
- Automatic lane rate switching for CDR lock up to five different combinations of baud rates and modulation types
- Low latency: <2000 ps (typical) at 26.5625 GBd
- Continuously adaptive time linear equalizer (CTLE), RX feed-forward equalizer (FFE), and decision feedback equalizer (DFE) to support 30+ dB channel loss at 13.28 GHz
- Integrated 2×2 crosspoint
- Adjustable 4-tap TX FFE filter
- Gearbox mode support (NRZ/PAM4 bit mux/demux, NRZ/PAM4 serializer/deserializer)
- On-chip eye opening monitor (EOM), PRBS generator, and PRBS checker for debug
- Dual 1.8-V and 1.2-V supplies
- −40°C to +85°C operating temperature range
- 8.00 mm × 13.00 mm BGA package with integrated AC coupling capacitors

2 Applications

- Active electrical cables (AEC) (QSFP-DD, OSFP)
- Front-port C2M attachment unit interface (AUI) jitter cleaning
- Backplane (KR) and midplane C2C attachment unit interface (AUI) reach extension
- Speed doubling (gearbox) with NRZ-to-PAM4 aggregation and de-aggregation

3 Description

The DS560DF810 is an eight-channel multi-rate retimer with integrated signal conditioning. It extends the reach and robustness of long, lossy, crosstalk-impaired high-speed serial links.

Each channel in the DS560DF810 independently locks to symbol rates (PAM4 and NRZ) in a continuous range from 19.6 to 28.9 GBd or to any supported sub-rate. The integrated CDR function is an excellent choice for front-port optical module applications to reset the jitter budget and retime the high-speed serial data. These features allow for individual lane forward error correction (FEC) pass-through. In addition, the DS560DF810 supports automatic lane rate switching for CDR lock up to five different combinations of baud rates and modulation types without host intervention.

The advanced equalization features of the DS560DF810 include a continuously adaptive continuous-time linear equalizer (CTLE), RX feed-forward equalizer (FFE), decision feedback equalizer (DFE), and a programmable, low-jitter 4-tap TX feed-forward equalizer (FFE) filter. These features enable reach extension for lossy interconnects such as direct-attach copper (DAC) cables and backplanes with multiple connectors and crosstalk.

Package Information

PART NUMBER	PACKAGE ⁽¹⁾	PACKAGE SIZE ⁽²⁾
DS560DF810	ALU (fcBGA, 135)	13 mm × 8 mm

(1) For all available packages, see the orderable addendum at the end of the data sheet.

(2) The package size (length × width) is a nominal value and includes pins, where applicable.

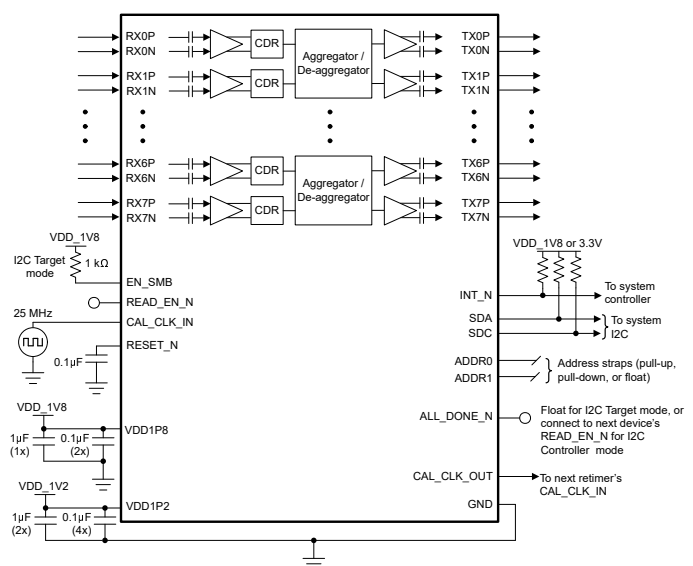

Simplified Schematic



Table of Contents

1 Features	1	6.2 Receiving Notification of Documentation Updates.....	4
2 Applications	1	6.3 Support Resources.....	4
3 Description	1	6.4 Trademarks.....	4
4 Revision History	2	6.5 Electrostatic Discharge Caution.....	4
5 Description (continued)	3	6.6 Glossary.....	4
6 Device and Documentation Support	4	7 Mechanical, Packaging, and Orderable Information	4
6.1 Documentation Support.....	4		

4 Revision History

NOTE: Page numbers for previous revisions may differ from page numbers in the current version.

Changes from Revision A (December 2022) to Revision B (June 2023) Page

- Added PAM4 serializer or deserializer support in the *Features* section..... 1
- Updated the *Package Information* table format to include package leads..... 1

Changes from Revision * (October 2021) to Revision A (December 2022) Page

- Changed the status of the data sheet from: *Advanced Information* to: *Production Data* 1

5 Description (continued)

The DS560DF810 is equipped with a bit mux and de-mux gearbox for simple NRZ-to-PAM4 or PAM4-to-NRZ conversion between host and module. The gearbox is capable of aggregating a pair of NRZ inputs up to 28.9 GBd into one 28.9 GBd PAM4 output as well as de-aggregating a single 28.9 GBd PAM4 input into a pair of 28.9 GBd NRZ outputs.

The DS560DF810 implements a full 2×2 crosspoint between each pair of adjacent channels after the CDR to enable fast and flexible lane switching for PCB routing flexibility, 2-to-1 multiplexing and 1-to-2 de-multiplexing for failover redundancy, and 1-to-2 fanout for diagnostic monitoring. In addition, integrated physical AC coupling capacitors (TX and RX) eliminate the need for external capacitors on the PCB. These features reduce PCB routing complexity and bill of material (BOM) cost.

Diagnostic capabilities include a non-destructive PAM4/NRZ vertical eye height monitor, a 2D PAM4/NRZ eye opening monitor (EOM), PRBS pattern generator with error injector module, PRBS error checker, and on-die temperature sensor. These features help to gauge the margin of the link and can be used to monitor the health of the system over time.

The DS560DF810 can be configured either through I²C or through an external EEPROM. Up to 16 devices can share a single EEPROM.

6 Device and Documentation Support

6.1 Documentation Support

6.1.1 Related Documentation

For related documentation, see the following:

- Texas Instruments, [DS560DFXX0 Programmer's Guide](#)
- Texas Instruments, [DS560DF810EVM User's Guide](#)
- Texas Instruments, [Implementation of TI 56Gbps PAM4 Retimers in Direct Attach Copper Cable Applications](#)

6.2 Receiving Notification of Documentation Updates

To receive notification of documentation updates, navigate to the device product folder on [ti.com](https://www.ti.com). Click on *Subscribe to updates* to register and receive a weekly digest of any product information that has changed. For change details, review the revision history included in any revised document.

6.3 Support Resources

[TI E2E™ support forums](#) are an engineer's go-to source for fast, verified answers and design help — straight from the experts. Search existing answers or ask your own question to get the quick design help you need.

Linked content is provided "AS IS" by the respective contributors. They do not constitute TI specifications and do not necessarily reflect TI's views; see TI's [Terms of Use](#).

6.4 Trademarks

Ethernet™ is a trademark of Fuji Xerox Co., Ltd.

InfiniBand™ is a trademark of InfiniBand Trade Association.

TI E2E™ is a trademark of Texas Instruments.

All trademarks are the property of their respective owners.

6.5 Electrostatic Discharge Caution



This integrated circuit can be damaged by ESD. Texas Instruments recommends that all integrated circuits be handled with appropriate precautions. Failure to observe proper handling and installation procedures can cause damage.

ESD damage can range from subtle performance degradation to complete device failure. Precision integrated circuits may be more susceptible to damage because very small parametric changes could cause the device not to meet its published specifications.

6.6 Glossary

[TI Glossary](#) This glossary lists and explains terms, acronyms, and definitions.

7 Mechanical, Packaging, and Orderable Information

The following pages include mechanical, packaging, and orderable information. This information is the most current data available for the designated devices. This data is subject to change without notice and revision of this document. For browser-based versions of this data sheet, refer to the left-hand navigation.

PACKAGING INFORMATION

Orderable Device	Status (1)	Package Type	Package Drawing	Pins	Package Qty	Eco Plan (2)	Lead finish/ Ball material (6)	MSL Peak Temp (3)	Op Temp (°C)	Device Marking (4/5)	Samples
DS560DF810ALUR	ACTIVE	FCCSP	ALU	135	1000	RoHS & Green	SNAGCU	Level-3-260C-168 HR	-40 to 85	DS560DF8E0	Samples
DS560DF810ALUT	ACTIVE	FCCSP	ALU	135	250	RoHS & Green	SNAGCU	Level-3-260C-168 HR	-40 to 85	DS560DF8E0	Samples

(1) The marketing status values are defined as follows:

ACTIVE: Product device recommended for new designs.

LIFEBUY: TI has announced that the device will be discontinued, and a lifetime-buy period is in effect.

NRND: Not recommended for new designs. Device is in production to support existing customers, but TI does not recommend using this part in a new design.

PREVIEW: Device has been announced but is not in production. Samples may or may not be available.

OBSOLETE: TI has discontinued the production of the device.

(2) **RoHS:** TI defines "RoHS" to mean semiconductor products that are compliant with the current EU RoHS requirements for all 10 RoHS substances, including the requirement that RoHS substance do not exceed 0.1% by weight in homogeneous materials. Where designed to be soldered at high temperatures, "RoHS" products are suitable for use in specified lead-free processes. TI may reference these types of products as "Pb-Free".

RoHS Exempt: TI defines "RoHS Exempt" to mean products that contain lead but are compliant with EU RoHS pursuant to a specific EU RoHS exemption.

Green: TI defines "Green" to mean the content of Chlorine (Cl) and Bromine (Br) based flame retardants meet JS709B low halogen requirements of <=1000ppm threshold. Antimony trioxide based flame retardants must also meet the <=1000ppm threshold requirement.

(3) MSL, Peak Temp. - The Moisture Sensitivity Level rating according to the JEDEC industry standard classifications, and peak solder temperature.

(4) There may be additional marking, which relates to the logo, the lot trace code information, or the environmental category on the device.

(5) Multiple Device Markings will be inside parentheses. Only one Device Marking contained in parentheses and separated by a "~" will appear on a device. If a line is indented then it is a continuation of the previous line and the two combined represent the entire Device Marking for that device.

(6) Lead finish/Ball material - Orderable Devices may have multiple material finish options. Finish options are separated by a vertical ruled line. Lead finish/Ball material values may wrap to two lines if the finish value exceeds the maximum column width.

Important Information and Disclaimer:The information provided on this page represents TI's knowledge and belief as of the date that it is provided. TI bases its knowledge and belief on information provided by third parties, and makes no representation or warranty as to the accuracy of such information. Efforts are underway to better integrate information from third parties. TI has taken and continues to take reasonable steps to provide representative and accurate information but may not have conducted destructive testing or chemical analysis on incoming materials and chemicals. TI and TI suppliers consider certain information to be proprietary, and thus CAS numbers and other limited information may not be available for release.

In no event shall TI's liability arising out of such information exceed the total purchase price of the TI part(s) at issue in this document sold by TI to Customer on an annual basis.

TAPE AND REEL INFORMATION

QUADRANT ASSIGNMENTS FOR PIN 1 ORIENTATION IN TAPE

*All dimensions are nominal

Device	Package Type	Package Drawing	Pins	SPQ	Reel Diameter (mm)	Reel Width W1 (mm)	A0 (mm)	B0 (mm)	K0 (mm)	P1 (mm)	W (mm)	Pin1 Quadrant
DS560DF810ALUR	FCCSP	ALU	135	1000	330.0	24.4	8.4	13.4	2.45	12.0	24.0	Q2
DS560DF810ALUT	FCCSP	ALU	135	250	330.0	24.4	8.4	13.4	2.45	12.0	24.0	Q2

TAPE AND REEL BOX DIMENSIONS

*All dimensions are nominal

Device	Package Type	Package Drawing	Pins	SPQ	Length (mm)	Width (mm)	Height (mm)
DS560DF810ALUR	FCCSP	ALU	135	1000	336.6	336.6	41.3
DS560DF810ALUT	FCCSP	ALU	135	250	336.6	336.6	41.3

ALU0135A

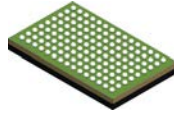

PACKAGE OUTLINE

FCBGA - 1.55 mm max height

PLASTIC BALL GRID ARRAY

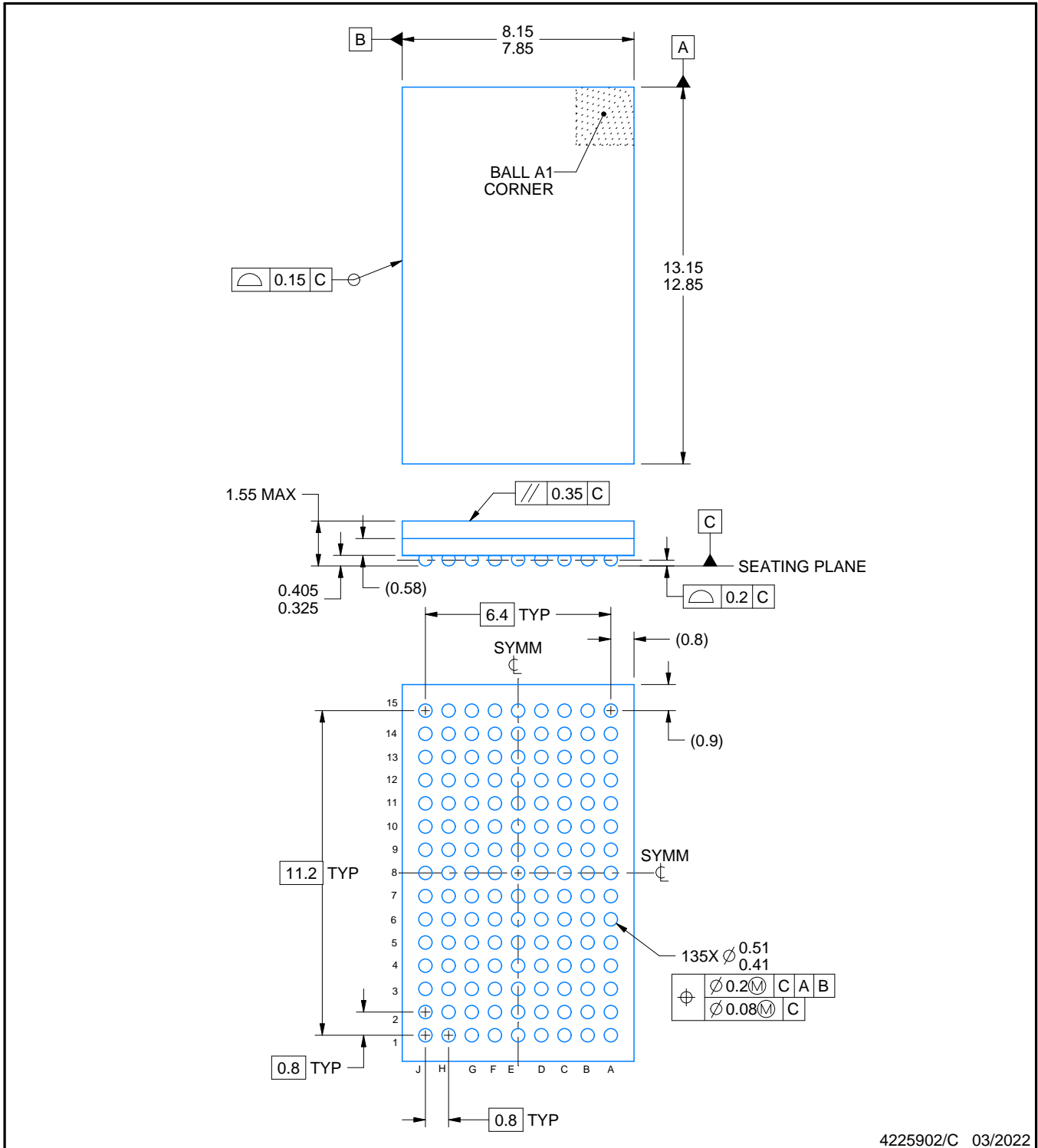

NOTES:

1. All linear dimensions are in millimeters. Any dimensions in parenthesis are for reference only. Dimensioning and tolerancing per ASME Y14.5M.
2. This drawing is subject to change without notice.

EXAMPLE BOARD LAYOUT

ALU0135A

FCBGA - 1.55 mm max height

PLASTIC BALL GRID ARRAY

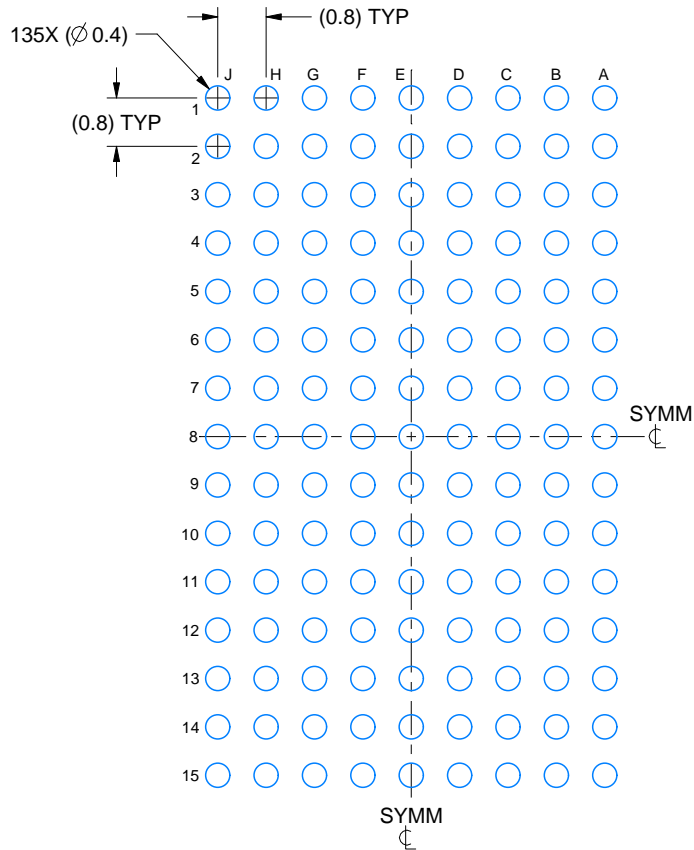

LAND PATTERN EXAMPLE
EXPOSED METAL SHOWN
SCALE: 8X

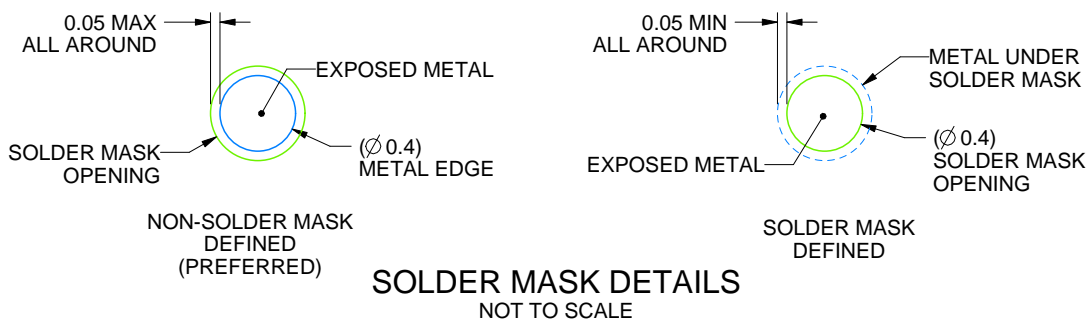

SOLDER MASK DETAILS
NOT TO SCALE

4225902/C 03/2022

NOTES: (continued)

- Final dimensions may vary due to manufacturing tolerance considerations and also routing constraints. For information, see Texas Instruments literature number SPRAA99 (www.ti.com/lit/spraa99).

EXAMPLE STENCIL DESIGN

ALU0135A

FCBGA - 1.55 mm max height

PLASTIC BALL GRID ARRAY

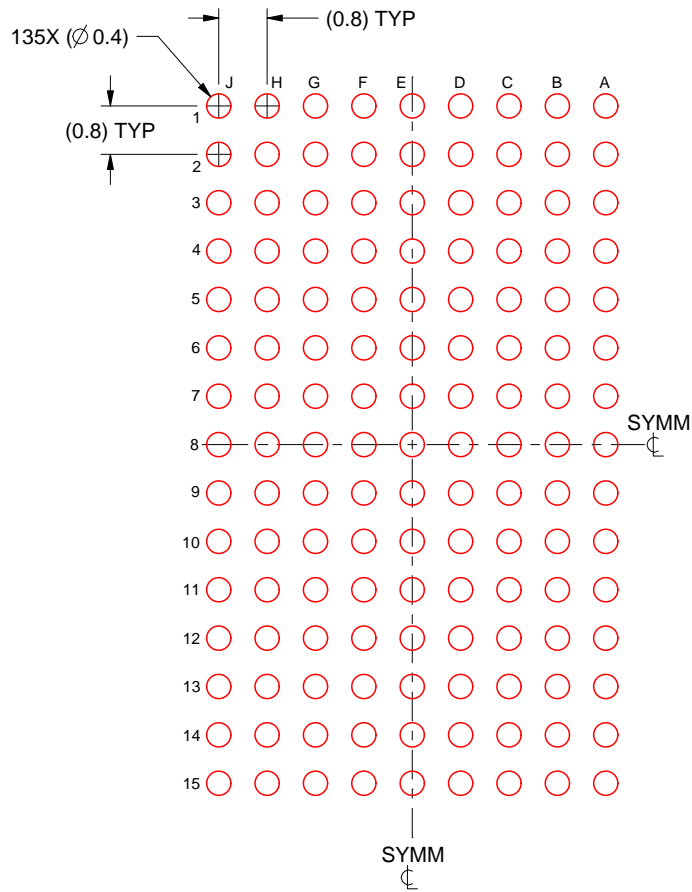

SOLDER PASTE EXAMPLE
BASED ON 0.125 mm THICK STENCIL
SCALE: 8X

4225902/C 03/2022

NOTES: (continued)

4. Laser cutting apertures with trapezoidal walls and rounded corners may offer better paste release.

IMPORTANT NOTICE AND DISCLAIMER

TI PROVIDES TECHNICAL AND RELIABILITY DATA (INCLUDING DATA SHEETS), DESIGN RESOURCES (INCLUDING REFERENCE DESIGNS), APPLICATION OR OTHER DESIGN ADVICE, WEB TOOLS, SAFETY INFORMATION, AND OTHER RESOURCES "AS IS" AND WITH ALL FAULTS, AND DISCLAIMS ALL WARRANTIES, EXPRESS AND IMPLIED, INCLUDING WITHOUT LIMITATION ANY IMPLIED WARRANTIES OF MERCHANTABILITY, FITNESS FOR A PARTICULAR PURPOSE OR NON-INFRINGEMENT OF THIRD PARTY INTELLECTUAL PROPERTY RIGHTS.

These resources are intended for skilled developers designing with TI products. You are solely responsible for (1) selecting the appropriate TI products for your application, (2) designing, validating and testing your application, and (3) ensuring your application meets applicable standards, and any other safety, security, regulatory or other requirements.

These resources are subject to change without notice. TI grants you permission to use these resources only for development of an application that uses the TI products described in the resource. Other reproduction and display of these resources is prohibited. No license is granted to any other TI intellectual property right or to any third party intellectual property right. TI disclaims responsibility for, and you will fully indemnify TI and its representatives against, any claims, damages, costs, losses, and liabilities arising out of your use of these resources.

TI's products are provided subject to [TI's Terms of Sale](#) or other applicable terms available either on [ti.com](https://www.ti.com) or provided in conjunction with such TI products. TI's provision of these resources does not expand or otherwise alter TI's applicable warranties or warranty disclaimers for TI products.

TI objects to and rejects any additional or different terms you may have proposed.

Mailing Address: Texas Instruments, Post Office Box 655303, Dallas, Texas 75265
Copyright © 2024, Texas Instruments Incorporated