

INA241x-Q1 AEC-Q100, –5V to 110V, Bidirectional, Ultra-Precise Current Sense Amplifier With Enhanced PWM Rejection

1 Features

- AEC-Q100 qualified for automotive applications:
 - Temperature grade 1: –40°C to 125°C, T_A
- **Functional Safety-Capable**
 - [Documentation available to aid functional safety system design](#)
- Enhanced PWM rejection optimized for systems subject to switching common-mode voltages
 - Supports switching frequencies up to 125kHz
- Wide common-mode voltage:
 - Operational voltage: –5V to 110V
 - Survival voltage: –20V to 120V
- Bidirectional operation
- High small signal bandwidth: 1.1MHz (at all gains)
- Slew rate: 8V/μs
- Step response settling time to 1%: 1μs
- Excellent CMRR
 - 166dB DC-CMRR
 - 104dB AC-CMRR at 100kHz
 - 89dB AC-CMRR at 1MHz
- Accuracy:
 - Gain error (maximum)
 - Version A: ±0.01%, ±1ppm/°C drift
 - Version B: ±0.1%, ±5ppm/°C drift
 - Offset voltage (maximum)
 - Version A: ±10μV, ±0.1μV/°C drift
 - Version B: ±150μV, ±0.5μV/°C drift
- Available gains:
 - INA241A1-Q1 : 10V/V
 - INA241A2-Q1 : 20V/V
 - INA241A3-Q1 : 50V/V
 - INA241A4-Q1 : 100V/V
 - INA241A5-Q1 : 200V/V
- Package options: SOT23-8, VSSOP-8, SOIC-8, VSSOP-10

2 Applications

- [eTurbo/charger](#)
- [Electric power steering \(EPS\)](#)
- [Starter/generator](#)
- [Regenerative braking](#)
- [Brake system](#)

3 Description

The INA241x-Q1 is an ultra-precise, bidirectional current sense amplifier that can measure voltage drops across shunt resistors over a wide common-mode range from –5V to 110V, independent of the supply voltage. The high-precision current measurement is achieved through a combination of low offset voltage (±10μV, maximum), small gain error (±0.01%, maximum) and a high DC CMRR (typical 166dB). The INA241x-Q1 is designed for high voltage, bidirectional measurements in switching systems that see large common-mode voltage transients at the device inputs. The enhanced PWM rejection circuitry inside the INA241x-Q1 provides minimal signal disturbance at the output due to the common-mode voltage transitions at the input.

The INA241x-Q1 operates from a single 2.7V to 20V supply, drawing 2.5mA of supply current. The INA241x-Q1 is available in five gain options: 10V/V, 20V/V, 50V/V, 100V/V, and 200V/V. Multiple gain options allow for optimization between available shunt resistor values and wide output dynamic range requirements.

The INA241x-Q1 is specified over operating temperature range of –40°C to 125°C.

Package Information

PART NUMBER	PACKAGE ⁽¹⁾	PACKAGE SIZE ⁽²⁾
INA241A-Q1 INA241B-Q1	DDF (SOT-23, 8)	2.9mm × 2.8mm
	DGK (VSSOP, 8)	3mm × 4.9mm
	D (SOIC, 8)	4.9mm × 6mm
	DGS (VSSOP, 10)	3mm × 4.9mm

- (1) For all available packages, see the package option addendum at the end of the data sheet.
- (2) The package size (length × width) is a nominal value and includes pins, where applicable.

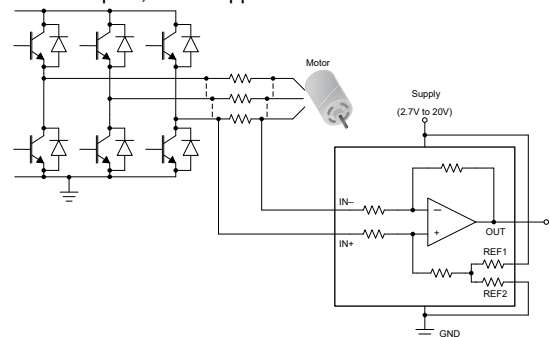

Typical Application - Inline Motor Control



Table of Contents

1 Features	1	7.4 Device Functional Modes.....	17
2 Applications	1	8 Application and Implementation	22
3 Description	1	8.1 Application Information.....	22
4 Device Comparison	2	8.2 Typical Application.....	23
5 Pin Configuration and Functions	2	8.3 Power Supply Recommendations.....	24
6 Specifications	4	8.4 Layout.....	24
6.1 Absolute Maximum Ratings.....	4	9 Device and Documentation Support	26
6.2 ESD Ratings.....	4	9.1 Documentation Support.....	26
6.3 Recommended Operating Conditions.....	4	9.2 Receiving Notification of Documentation Updates....	26
6.4 Thermal Information.....	4	9.3 Support Resources.....	26
6.5 Electrical Characteristics.....	5	9.4 Trademarks.....	26
6.6 Typical Characteristics.....	8	9.5 Electrostatic Discharge Caution.....	26
7 Detailed Description	15	9.6 Glossary.....	26
7.1 Overview.....	15	10 Revision History	26
7.2 Functional Block Diagram.....	15	11 Mechanical, Packaging, and Orderable Information	27
7.3 Feature Description.....	15		

4 Device Comparison

Table 4-1. Device Comparison

DEVICE NAME	GAIN
INA241A1-Q1, INA241B1-Q1	10V/V
INA241A2-Q1, INA241B2-Q1	20V/V
INA241A3-Q1, INA241B3-Q1	50V/V
INA241A4-Q1, INA241B4-Q1	100V/V
INA241A5-Q1, INA241B5-Q1	200V/V

5 Pin Configuration and Functions

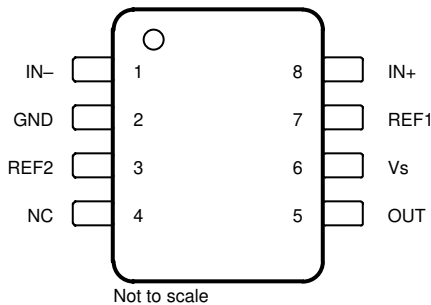

Figure 5-1. INA241x-Q1: DDF Package 8-Pin SOT-23 Top View

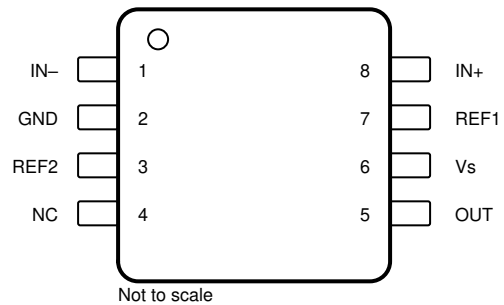

Figure 5-2. INA241x-Q1: D and DGK Package 8-Pin SOIC and 8-Pin VSSOP Top View

Table 5-1. Pin Functions: D, DDF and DGK Packages

PIN		TYPE	DESCRIPTION
NAME	NO.		
GND	2	Ground	Ground.
IN+	8	Input	Current-sense amplifier positive input. For high-side applications, connect to bus-voltage side of sense resistor. For low-side applications, connect to load side of sense resistor.
IN-	1	Input	Current-sense amplifier negative input. For high-side applications, connect to load side of sense resistor. For low-side applications, connect to ground side of sense resistor.
NC	4	Ground	Reserved. Connect to ground.
OUT	5	Output	Output voltage.

Table 5-1. Pin Functions: D, DDF and DGK Packages (continued)

PIN		TYPE	DESCRIPTION
NAME	NO.		
REF1	7	Input	Reference 1 voltage. Connect to voltage potential from 0V to V_S ; see Adjusting the Output With the Reference Pins for connection options.
REF2	3	Input	Reference 2 voltage. Connect to voltage potential from 0V to V_S ; see Adjusting the Output With the Reference Pins for connection options.
V_S	6	Power	Power supply, 2.7V to 20V

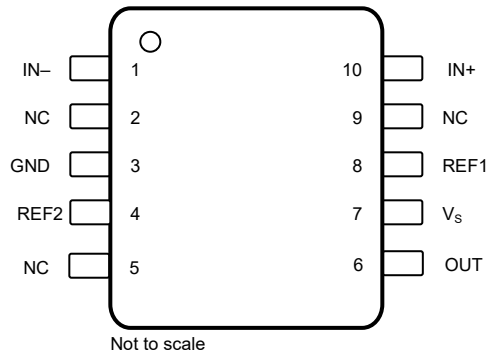

Figure 5-3. INA241x-Q1: DGS Package 10-Pin VSSOP Top View

Table 5-2. Pin Functions: DGS Package

PIN		TYPE	DESCRIPTION
NAME	NO.		
GND	3	Ground	Ground
IN+	10	Input	Current-sense amplifier positive input. For high-side applications, connect to bus-voltage side of sense resistor. For low-side applications, connect to load side of sense resistor.
IN-	1	Input	Current-sense amplifier negative input. For high-side applications, connect to load side of sense resistor. For low-side applications, connect to ground side of sense resistor.
NC	5	Ground	Reserved. Connect to ground.
NC	2	–	Leave unconnected
NC	9	–	Leave unconnected
OUT	6	Output	Output voltage
REF1	8	Input	Reference 1 voltage. Connect to voltage potential from 0V to V_S ; see Adjusting the Output With the Reference Pins for connection options.
REF2	4	Input	Reference 2 voltage. Connect to voltage potential from 0V to V_S ; see Adjusting the Output With the Reference Pins for connection options.
V_S	7	Power	Power supply, 2.7V to 20V

6 Specifications

6.1 Absolute Maximum Ratings

over operating free-air temperature range (unless otherwise noted)⁽¹⁾

		MIN	MAX	UNIT
Supply voltage (V _S)			22	V
Analog inputs, V _{IN+} , V _{IN-} ⁽²⁾	Differential (V _{IN+}) – (V _{IN-})	-30	30	V
	Common-mode	-20	120	V
REF1, REF2, NC inputs		GND – 0.3	V _S + 0.3	V
Output		GND – 0.3	V _S + 0.3	V
T _A	Operating temperature	-55	150	°C
T _J	Junction temperature		150	°C
T _{stg}	Storage temperature	-65	150	°C

- (1) Operation outside the Absolute Maximum Ratings may cause permanent device damage. Absolute Maximum Ratings do not imply functional operation of the device at these or any other conditions beyond those listed under Recommended Operating Conditions. If used outside the Recommended Operating Conditions but within the Absolute Maximum Ratings, the device may not be fully functional, and this may affect device reliability, functionality, performance, and shorten the device lifetime.
- (2) V_{IN+} and V_{IN-} are the voltages at the IN+ and IN- pins, respectively.

6.2 ESD Ratings

			VALUE	UNIT
V _(ESD)	Electrostatic discharge	Human body model (HBM), per AEC Q100-002 ⁽¹⁾ HBM ESD classification level 2	±2000	V
		Charged device model (CDM), per AEC Q100-011 CDM ESD classification level C6	±1000	

- (1) AEC Q100-002 indicates that HBM stressing shall be in accordance with the ANSI/ESDA/JEDEC JS-001 specification.

6.3 Recommended Operating Conditions

over operating free-air temperature range (unless otherwise noted)

		MIN	NOM	MAX	UNIT
V _{CM}	Common-mode input range	-5	48	110	V
V _S	Operating supply range	2.7	5	20	V
T _A	Ambient temperature	-40		125	°C

6.4 Thermal Information

THERMAL METRIC ⁽¹⁾		INA241x-Q1				UNIT
		DDF (SOT23)	DGK (VSSOP)	D (SOIC)	DGS (VSSOP)	
		8 PINS	8 PINS	8 PINS	10 PINS	
R _{θJA}	Junction-to-ambient thermal resistance	129.7	167.2	122.9	143.3	°C/W
R _{θJC(top)}	Junction-to-case (top) thermal resistance	58	58.9	54.7	49.2	°C/W
R _{θJB}	Junction-to-board thermal resistance	52.6	88.9	68.8	80	°C/W
Ψ _{JT}	Junction-to-top characterization parameter	2.3	8.1	12.2	2.6	°C/W
Ψ _{JB}	Junction-to-board characterization parameter	52.3	87.4	67.5	78.6	°C/W

- (1) For more information about traditional and new thermal metrics, see the [Semiconductor and IC Package Thermal Metrics](#) application note.

6.5 Electrical Characteristics

at $T_A = 25\text{ }^\circ\text{C}$, $V_S = 5\text{V}$, $V_{\text{SENSE}} = V_{\text{IN}+} - V_{\text{IN}-}$, $V_{\text{CM}} = V_{\text{IN}-} = 48\text{V}$, and $V_{\text{REF1}} = V_{\text{REF2}} = V_S / 2$ (unless otherwise noted)

PARAMETER		TEST CONDITIONS	MIN	TYP	MAX	UNIT
INPUT						
V_{CM}	Common-mode input range ⁽¹⁾	$V_{\text{IN}+}, V_{\text{IN}-} = -5\text{V to } 110\text{V}$, $V_{\text{SENSE}} = 0\text{mV}$ $T_A = -40\text{ }^\circ\text{C to } 125\text{ }^\circ\text{C}$	-5		110	V
CMRR	Common-mode rejection ratio, input-referred	$V_{\text{IN}+}, V_{\text{IN}-} = -5\text{V to } 110\text{V}$, $V_{\text{SENSE}} = 0\text{mV}$ $T_A = -40\text{ }^\circ\text{C to } 125\text{ }^\circ\text{C}$, INA241A-Q1	150	166		dB
		$V_{\text{IN}+}, V_{\text{IN}-} = -5\text{V to } 110\text{V}$, $V_{\text{SENSE}} = 0\text{mV}$ $T_A = -40\text{ }^\circ\text{C to } 125\text{ }^\circ\text{C}$, INA241B-Q1	120	130		
		$f = 50\text{kHz}$		105		
V_{os}	Offset voltage, input-referred	$V_{\text{SENSE}} = 0\text{mV}$, INA241A1-Q1		± 5	± 20	μV
		$V_{\text{SENSE}} = 0\text{mV}$, INA241A2-Q1		± 3	± 15	
		$V_{\text{SENSE}} = 0\text{mV}$, INA241A3-Q1, INA241A4-Q1		± 3	± 10	
		$V_{\text{SENSE}} = 0\text{mV}$, INA241A5-Q1		± 2	± 8	
		$V_{\text{SENSE}} = 0\text{mV}$, INA241B-Q1		± 25	± 150	
dV_{os}/dT	Offset voltage drift, input-referred	$T_A = -40\text{ }^\circ\text{C to } 125\text{ }^\circ\text{C}$, INA241A1-Q1		± 50	± 250	$\text{nV}/^\circ\text{C}$
		$T_A = -40\text{ }^\circ\text{C to } 125\text{ }^\circ\text{C}$, INA241A2-Q1		± 30	± 150	
		$T_A = -40\text{ }^\circ\text{C to } 125\text{ }^\circ\text{C}$, INA241A3-Q1, INA241A4-Q1, INA241A5-Q1		± 20	± 100	
		$T_A = -40\text{ }^\circ\text{C to } 125\text{ }^\circ\text{C}$, INA241B-Q1		± 100	± 500	
PSRR	Power-supply rejection ratio, input-referred	$V_S = 2.7\text{V to } 20\text{V}$, $V_{\text{SENSE}} = 0\text{mV}$, $V_{\text{REF1}} = V_{\text{REF2}} = 1\text{V}$, $T_A = -40\text{ }^\circ\text{C to } 125\text{ }^\circ\text{C}$, INA241A1-Q1		± 0.2	± 1	$\mu\text{V}/\text{V}$
		$V_S = 2.7\text{V to } 20\text{V}$, $V_{\text{SENSE}} = 0\text{mV}$, $V_{\text{REF1}} = V_{\text{REF2}} = 1\text{V}$, $T_A = -40\text{ }^\circ\text{C to } 125\text{ }^\circ\text{C}$, INA241A2-Q1		± 0.1	± 0.75	
		$V_S = 2.7\text{V to } 20\text{V}$, $V_{\text{SENSE}} = 0\text{mV}$, $V_{\text{REF1}} = V_{\text{REF2}} = 1\text{V}$, $T_A = -40\text{ }^\circ\text{C to } 125\text{ }^\circ\text{C}$, INA241A3-Q1, INA241A4-Q1, INA241A5-Q1		± 0.06	± 0.5	
		$V_S = 2.7\text{V to } 20\text{V}$, $V_{\text{SENSE}} = 0\text{mV}$, $V_{\text{REF1}} = V_{\text{REF2}} = 1\text{V}$, $T_A = -40\text{ }^\circ\text{C to } 125\text{ }^\circ\text{C}$, INA241B-Q1		± 1	± 10	
I_B	Input bias current	I_{B+}, I_{B-} , $V_{\text{SENSE}} = 0\text{mV}$	25	35	45	μA
	Reference input range		0		V_S	V
OUTPUT						
G	Gain	A1, B1 Devices		10		V/V
		A2, B2 Devices		20		V/V
		A3, B3 Devices		50		V/V
		A4, B4 Devices		100		V/V
		A5, B5 Devices		200		V/V

INA241A-Q1, INA241B-Q1

SBOSA31C – FEBRUARY 2023 – REVISED DECEMBER 2024

 at $T_A = 25^\circ\text{C}$, $V_S = 5\text{V}$, $V_{\text{SENSE}} = V_{\text{IN}+} - V_{\text{IN}-}$, $V_{\text{CM}} = V_{\text{IN}-} = 48\text{V}$, and $V_{\text{REF1}} = V_{\text{REF2}} = V_S / 2$ (unless otherwise noted)

PARAMETER		TEST CONDITIONS	MIN	TYP	MAX	UNIT
G _{ERR}	Gain Error	(GND + 50mV) < V _{OUT} < (V _S - 200mV), INA241A1-Q1, INA241A2-Q1, INA241A3-Q1		±0.002	±0.01	%
		(GND + 50mV) < V _{OUT} < (V _S - 200mV), INA241A4-Q1, INA241A5-Q1		±0.003	±0.015	
		(GND + 50mV) < V _{OUT} < (V _S - 200mV), INA241B-Q1		±0.02	±0.1	
	Gain Error Drift	T _A = -40°C to +125°C, INA241A1-Q1, INA241A2-Q1, INA241A3-Q1		±0.05	±1	ppm/°C
		T _A = -40°C to +125°C, INA241A4-Q1, INA241A5-Q1		±0.1	±2	
		T _A = -40°C to +125°C, INA241B-Q1		±0.2	±5	
	Non-Linearity Error		±0.001			%
	Maximum Capacitive Load	No sustained oscillations, No isolation resistor		1		nF
VOLTAGE OUTPUT						
	Swing to V _S Power Supply Rail	R _L = 10kΩ to GND, T _A = -40°C to +125°C		V _S - 0.07	V _S - 0.2	V
	Swing to Ground	R _L = 10kΩ to GND, V _{SENSE} = 0mV, V _{REF1} = V _{REF2} = 0V, T _A = -40°C to +125°C		8	20	mV
REFERENCE INPUT						
RVRR	Reference voltage rejection ratio, input-referred	V _{REF1} = V _{REF2} = 0.5V to 4.5V, T _A = -40°C to +125°C, INA241A1-Q1		±1	±2.5	μV/V
		V _{REF1} = V _{REF2} = 0.5V to 4.5V, T _A = -40°C to +125°C, INA241A2-Q1, INA241A3-Q1, INA241A4-Q1, INA241A5-Q1		±0.5	±1.5	
		V _{REF1} = V _{REF2} = 0.5V to 4.5V, T _A = -40°C to +125°C, INA241B-Q1,		±10	±20	
Reference divider accuracy		V _{OUT} = (V _{REF1} + V _{REF2}) / 2 at V _{SENSE} = 0mV, V _{REF1} = V _S , V _{REF2} = GND V _{REF1} = GND, V _{REF2} = V _S T _A = -40°C to +125°C, INA241A1-Q1, INA241A2-Q1		±0.002	±0.005	%
		V _{OUT} = (V _{REF1} + V _{REF2}) / 2 at V _{SENSE} = 0mV, V _{REF1} = V _S , V _{REF2} = GND V _{REF1} = GND, V _{REF2} = V _S T _A = -40°C to +125°C, INA241A3-Q1, INA241A4-Q1, INA241A5-Q1		±0.002	±0.01	
		V _{OUT} = (V _{REF1} + V _{REF2}) / 2 at V _{SENSE} = 0mV, V _{REF1} = V _S , V _{REF2} = GND V _{REF1} = GND, V _{REF2} = V _S T _A = -40°C to +125°C, INA241B-Q1		±0.02	±0.15	
FREQUENCY RESPONSE						
BW	Bandwidth	All Gains, -3dB Bandwidth		1.1		MHz

at $T_A = 25\text{ }^\circ\text{C}$, $V_S = 5\text{V}$, $V_{\text{SENSE}} = V_{\text{IN}+} - V_{\text{IN}-}$, $V_{\text{CM}} = V_{\text{IN}-} = 48\text{V}$, and $V_{\text{REF1}} = V_{\text{REF2}} = V_S / 2$ (unless otherwise noted)

PARAMETER		TEST CONDITIONS	MIN	TYP	MAX	UNIT
	Settling time	$V_{\text{IN}+}, V_{\text{IN}-} = 48\text{V}$, $V_{\text{OUT}} = 0.5\text{V}$ to 4.5V , Output settles to 0.5%		1.5		μs
		$V_{\text{IN}+}, V_{\text{IN}-} = 48\text{V}$, $V_{\text{OUT}} = 0.5\text{V}$ to 4.5V , Output settles to 1%		1		μs
		$V_{\text{IN}+}, V_{\text{IN}-} = 48\text{V}$, $V_{\text{OUT}} = 0.5\text{V}$ to 4.5V , Output settles to 5%		0.5		μs
SR	Slew Rate	Rising		8		$\text{V}/\mu\text{s}$
NOISE (Input referred)						
	Voltage noise density	A1, B1 Devices		62		$\text{nV}/\sqrt{\text{Hz}}$
		A2, B2 Devices		49		
		A3, B3 Devices		39		
		A4, B4 Devices		36		
		A5, B5 Devices		28		
POWER SUPPLY						
V_S	Supply Voltage		2.7		20	V
I_Q	Quiescent current	$V_{\text{SENSE}} = 0\text{mV}$		2.5	3	mA
		$V_{\text{SENSE}} = 0\text{mV}$, $T_A = -40\text{ }^\circ\text{C}$ to $+125\text{ }^\circ\text{C}$			3.2	mA
TEMPERATURE						
T_A	Specified Range		-40		125	$^\circ\text{C}$

(1) Common-mode voltage at both $V_{\text{IN}+}$ and $V_{\text{IN}-}$ must not exceed the specified common-mode input range.

6.6 Typical Characteristics

at $T_A = 25^\circ\text{C}$, $V_S = 5\text{V}$, $V_{\text{SENSE}} = V_{\text{IN}+} - V_{\text{IN}-}$, $V_{\text{CM}} = V_{\text{IN}-} = 48\text{V}$, and $V_{\text{REF}1} = V_{\text{REF}2} = V_S / 2$ (unless otherwise noted)

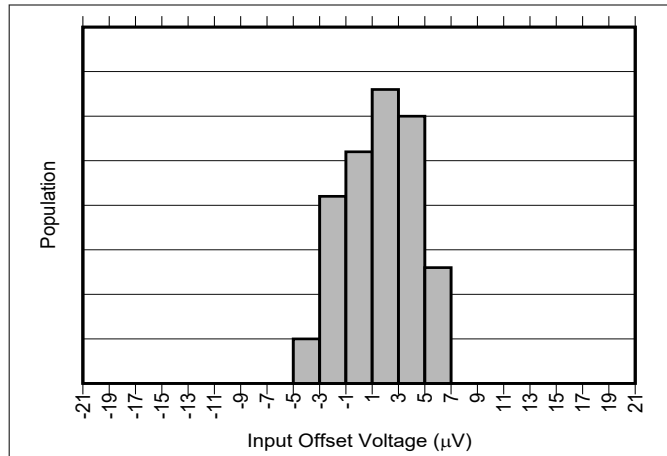

Figure 6-1. INA241A1-Q1 Input Offset Production Distribution

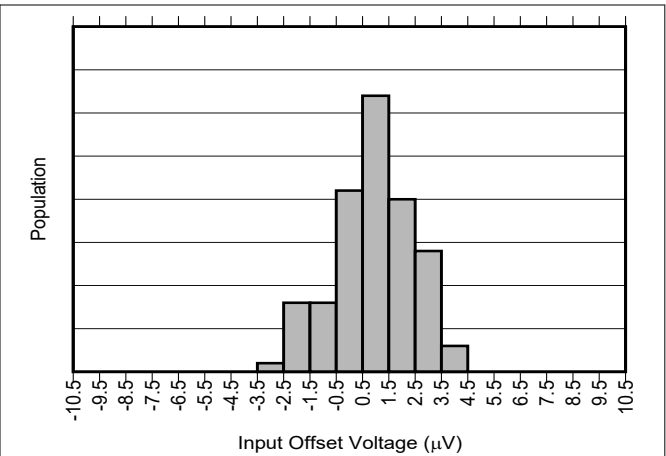

Figure 6-2. INA241A2-Q1 Input Offset Production Distribution

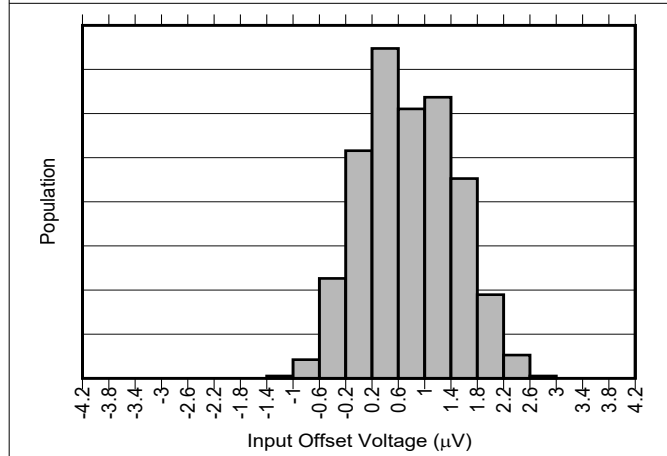

Figure 6-3. INA241A3-Q1 and INA241A4-Q1 Input Offset Production Distribution

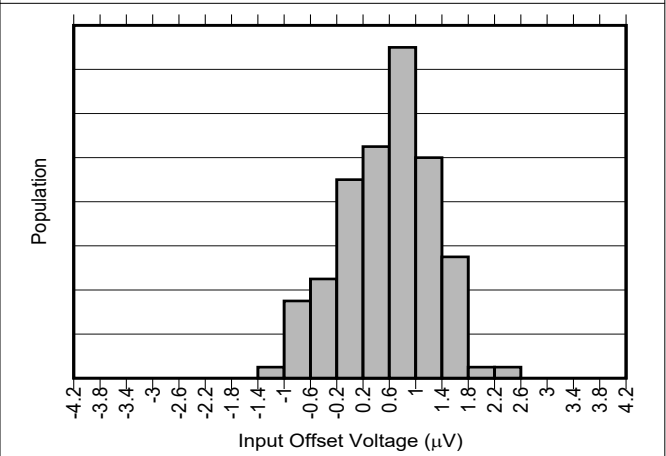

Figure 6-4. INA241A5-Q1 Input Offset Production Distribution

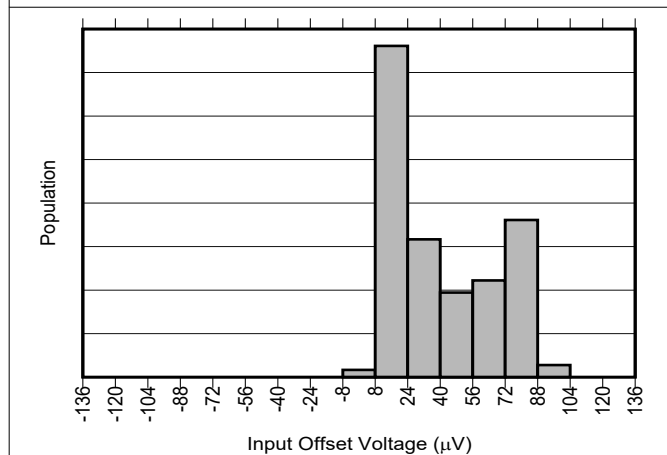

Figure 6-5. All Gains INA241B-Q1 Input Offset Production Distribution

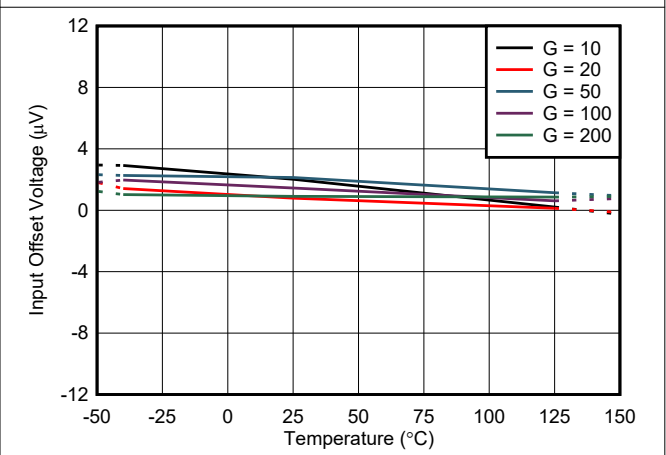

Figure 6-6. Input Offset Voltage vs Temperature

6.6 Typical Characteristics (continued)

at $T_A = 25^\circ\text{C}$, $V_S = 5\text{V}$, $V_{\text{SENSE}} = V_{\text{IN}+} - V_{\text{IN}-}$, $V_{\text{CM}} = V_{\text{IN}-} = 48\text{V}$, and $V_{\text{REF}1} = V_{\text{REF}2} = V_S / 2$ (unless otherwise noted)

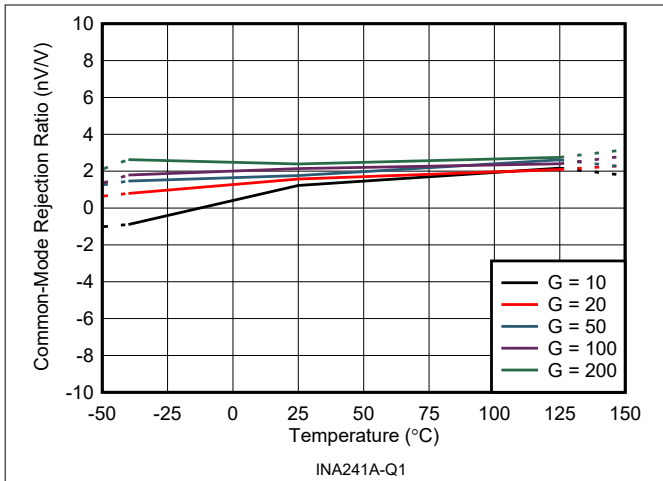

Figure 6-7. Common-Mode Rejection Ratio vs Temperature

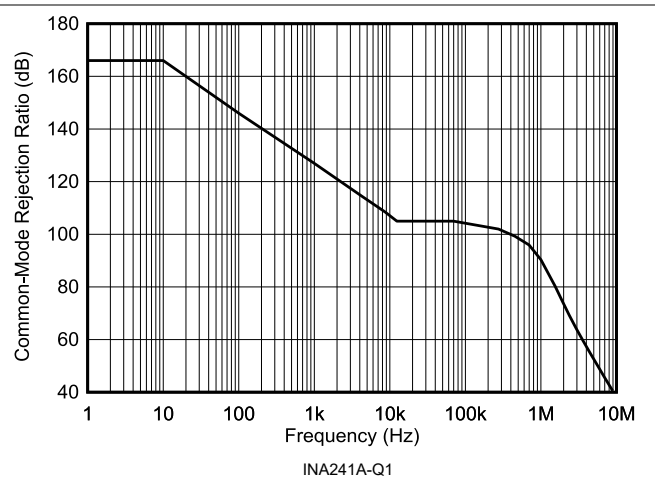

Figure 6-8. Common-Mode Rejection Ratio vs Frequency

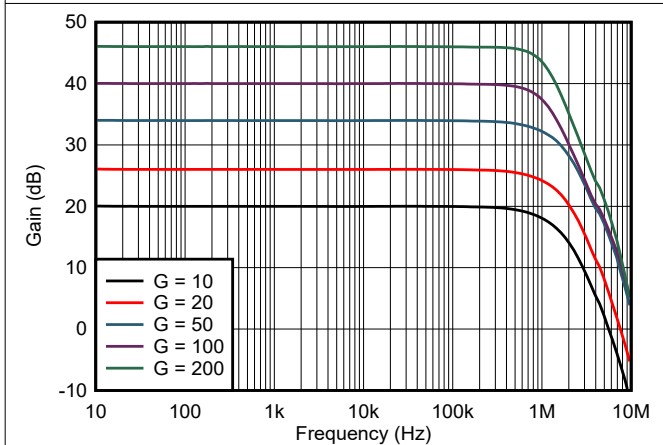

Figure 6-9. Gain vs Frequency

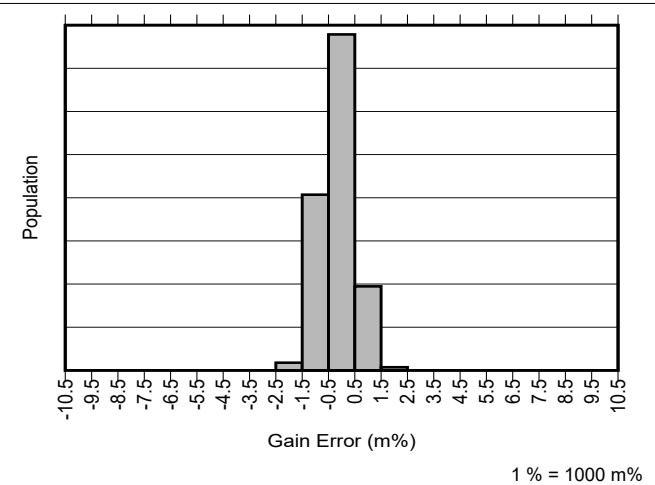

Figure 6-10. INA241A1-Q1, INA241A2-Q1 and INA241A3-Q1 Gain Error Production Distribution

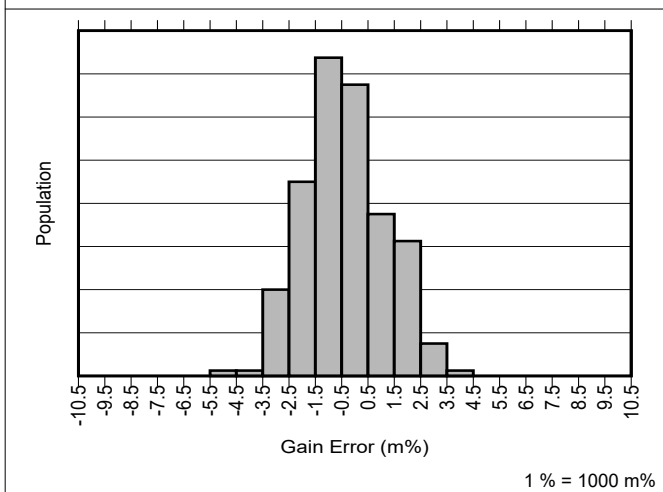

Figure 6-11. INA241A4-Q1 and INA241A5-Q1 Gain Error Production Distribution

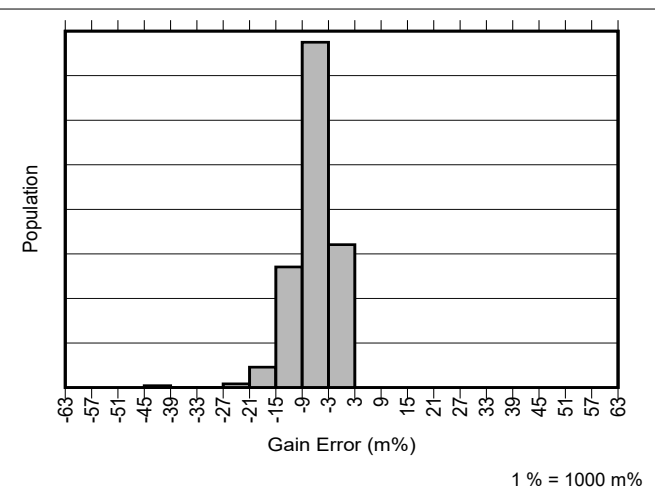

Figure 6-12. All Gains INA241B-Q1 Gain Error Production Distribution

6.6 Typical Characteristics (continued)

at $T_A = 25^\circ\text{C}$, $V_S = 5\text{V}$, $V_{\text{SENSE}} = V_{\text{IN}+} - V_{\text{IN}-}$, $V_{\text{CM}} = V_{\text{IN}-} = 48\text{V}$, and $V_{\text{REF}1} = V_{\text{REF}2} = V_S / 2$ (unless otherwise noted)

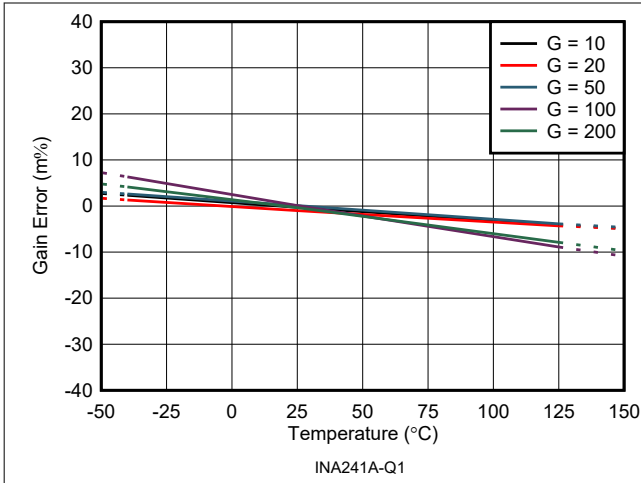

Figure 6-13. Gain Error vs Temperature

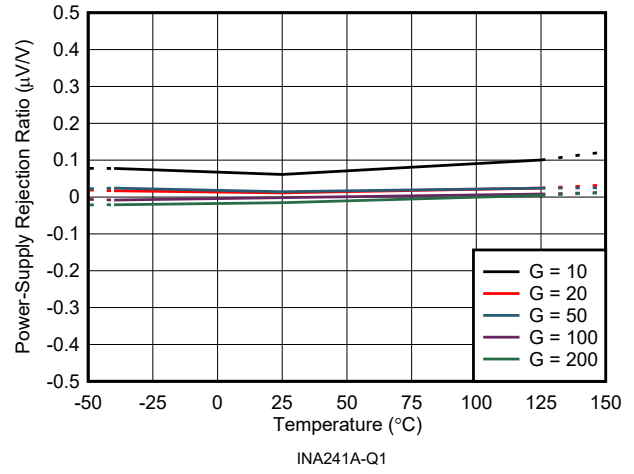

Figure 6-14. Power-Supply Rejection Ratio vs Temperature

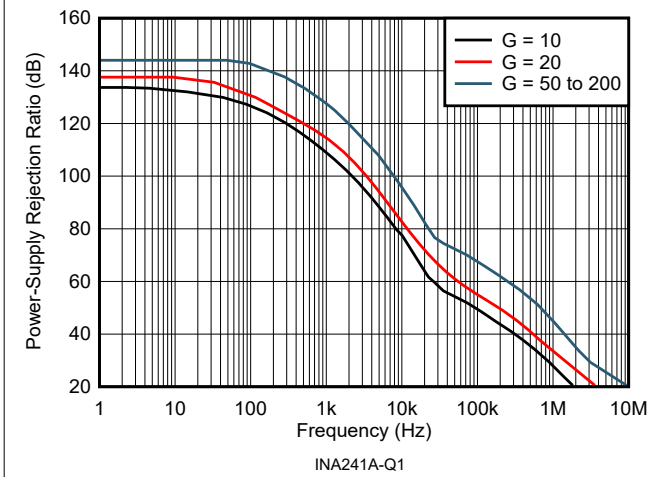

Figure 6-15. Power-Supply Rejection Ratio vs Frequency

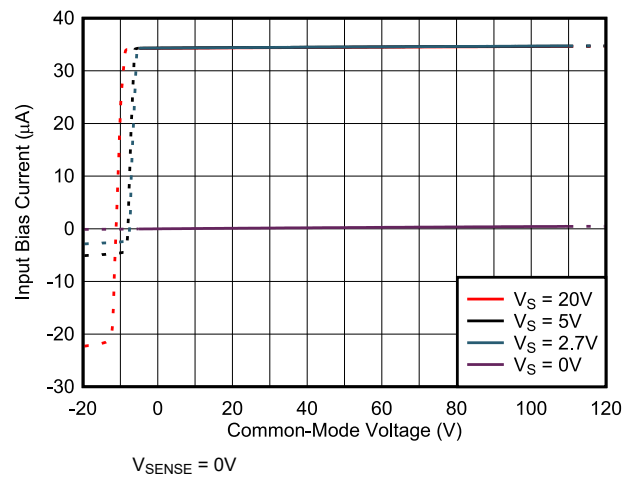

Figure 6-16. Input Bias Current vs Common-Mode Voltage

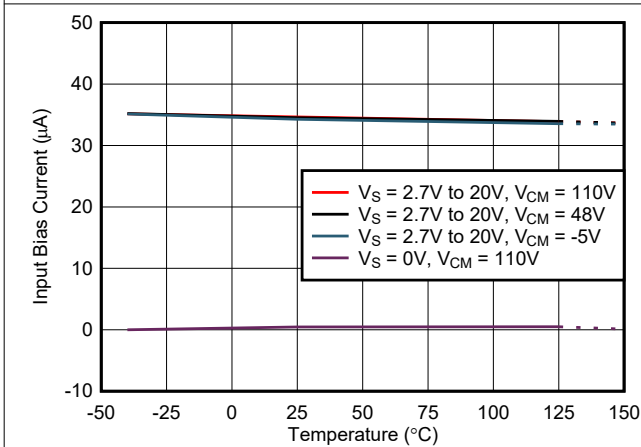

Figure 6-17. Input Bias Current vs Temperature

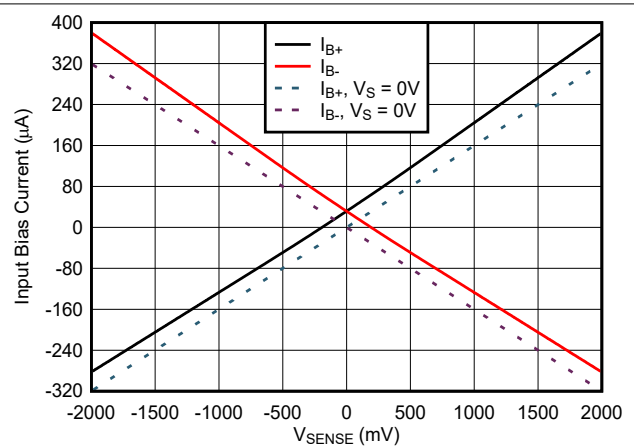

Figure 6-18. INA241x1-Q1 Input Bias Current vs V_{SENSE}

6.6 Typical Characteristics (continued)

at $T_A = 25^\circ\text{C}$, $V_S = 5\text{V}$, $V_{\text{SENSE}} = V_{\text{IN}+} - V_{\text{IN}-}$, $V_{\text{CM}} = V_{\text{IN}-} = 48\text{V}$, and $V_{\text{REF}1} = V_{\text{REF}2} = V_S / 2$ (unless otherwise noted)

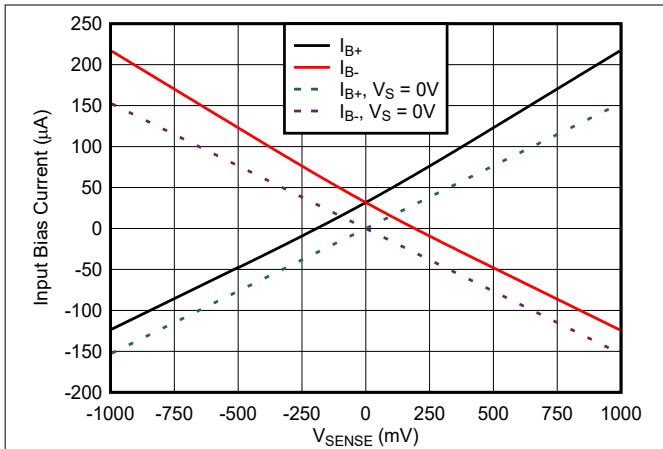

Figure 6-19. INA241x2-Q1 Input Bias Current vs V_{SENSE}

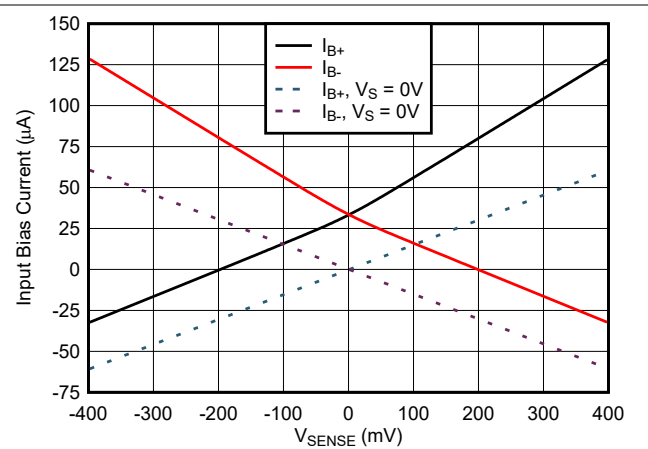

Figure 6-20. INA241x3-Q1 and INA241x4-Q1 Input Bias Current vs V_{SENSE}

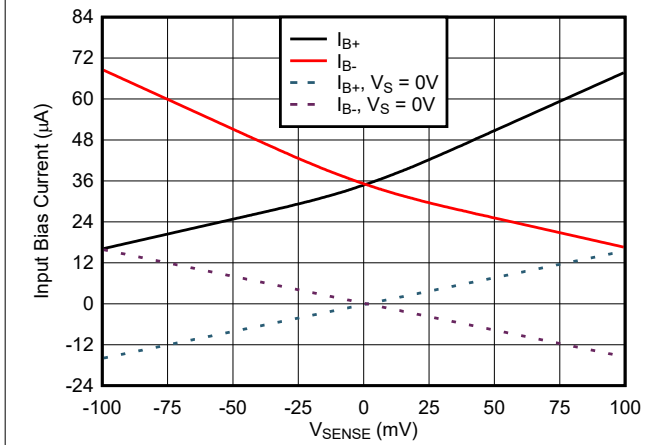

Figure 6-21. INA241x5-Q1 Input Bias Current vs V_{SENSE}

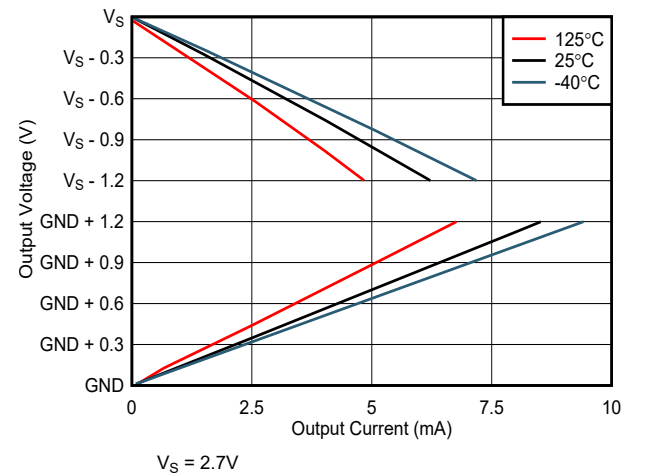

Figure 6-22. Output Voltage vs Output Current

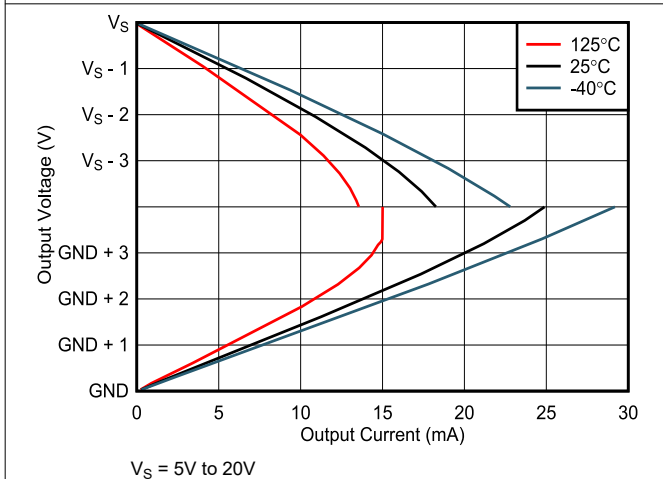

Figure 6-23. Output Voltage vs Output Current

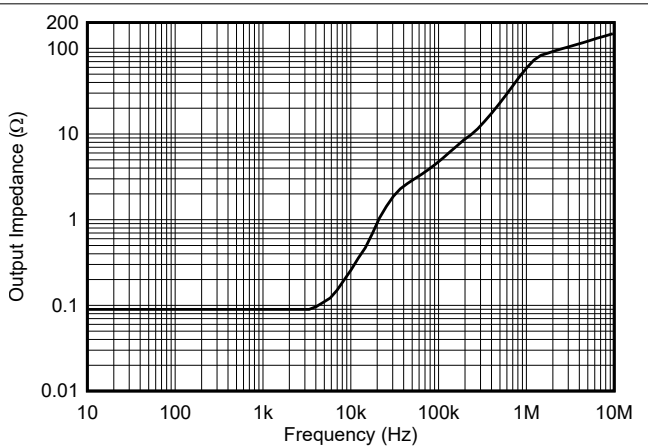

Figure 6-24. Output Impedance vs Frequency

6.6 Typical Characteristics (continued)

at $T_A = 25^\circ\text{C}$, $V_S = 5\text{V}$, $V_{\text{SENSE}} = V_{\text{IN}+} - V_{\text{IN}-}$, $V_{\text{CM}} = V_{\text{IN}-} = 48\text{V}$, and $V_{\text{REF1}} = V_{\text{REF2}} = V_S / 2$ (unless otherwise noted)

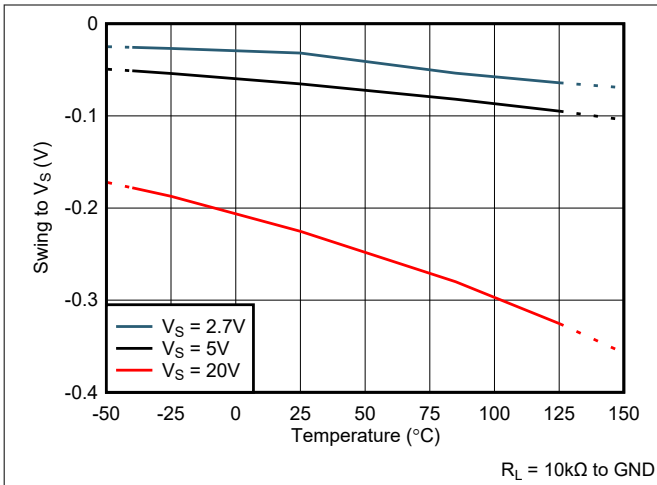

Figure 6-25. Swing to Supply vs Temperature

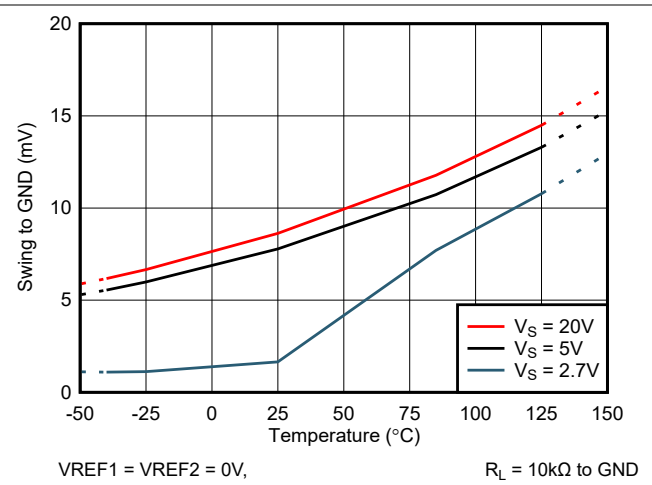

Figure 6-26. Swing to GND vs Temperature

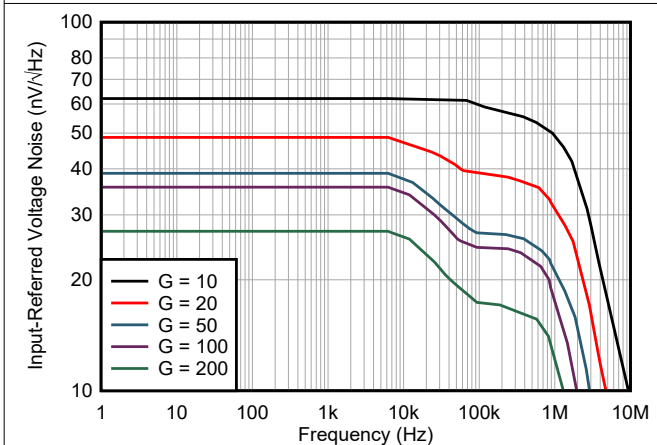

Figure 6-27. Input Referred Noise vs Frequency

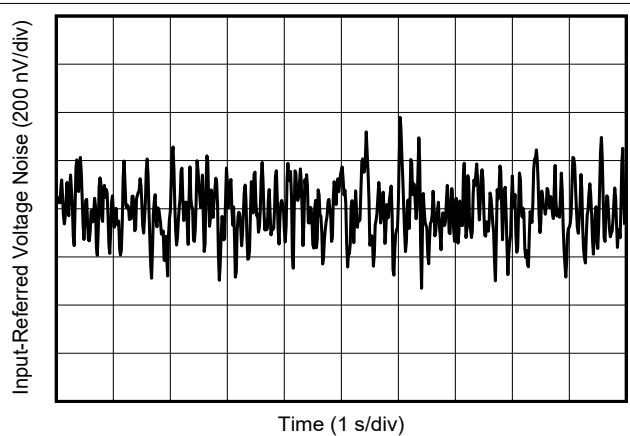

Figure 6-28. 0.1Hz to 10Hz Voltage Noise

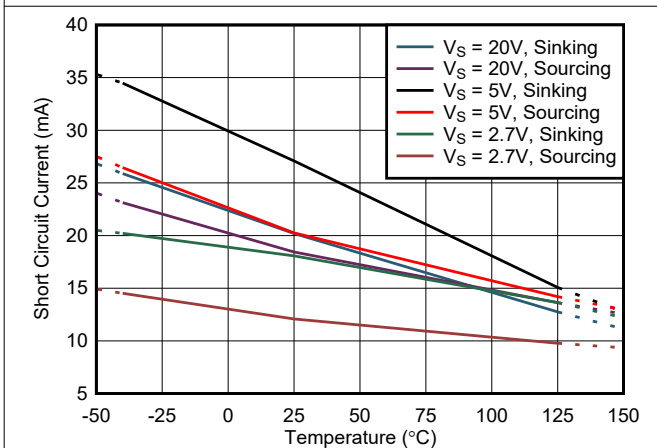

Figure 6-29. Short-Circuit Current vs Temperature

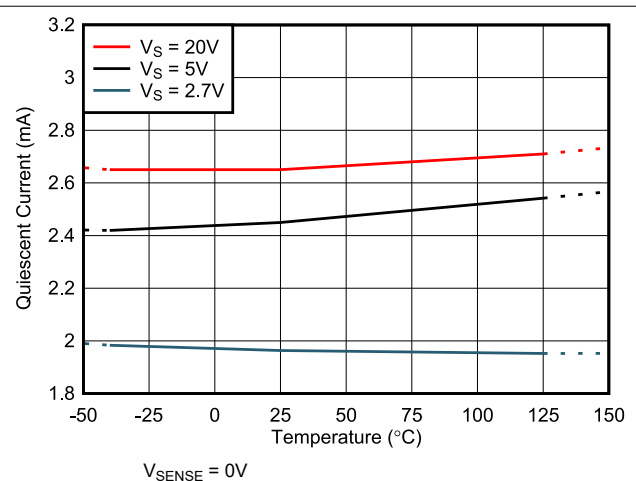
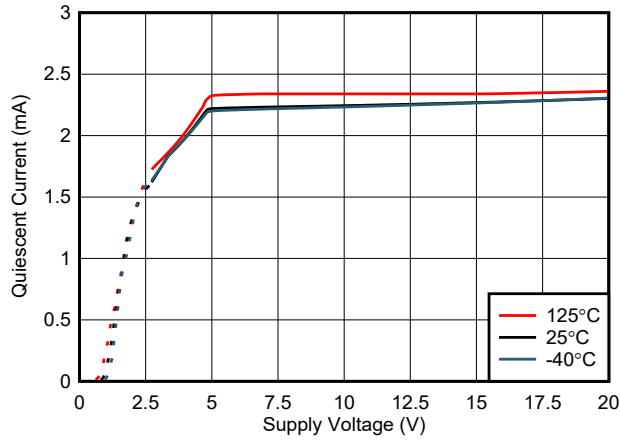

Figure 6-30. Quiescent Current vs Temperature

6.6 Typical Characteristics (continued)

at $T_A = 25^\circ\text{C}$, $V_S = 5\text{V}$, $V_{\text{SENSE}} = V_{\text{IN}+} - V_{\text{IN}-}$, $V_{\text{CM}} = V_{\text{IN}-} = 48\text{V}$, and $V_{\text{REF1}} = V_{\text{REF2}} = V_S / 2$ (unless otherwise noted)



$V_{\text{REF1}} = V_{\text{REF2}} = 0\text{V}$,
 $V_{\text{SENSE}} = 0\text{V}$

Figure 6-31. Quiescent Current vs Supply Voltage

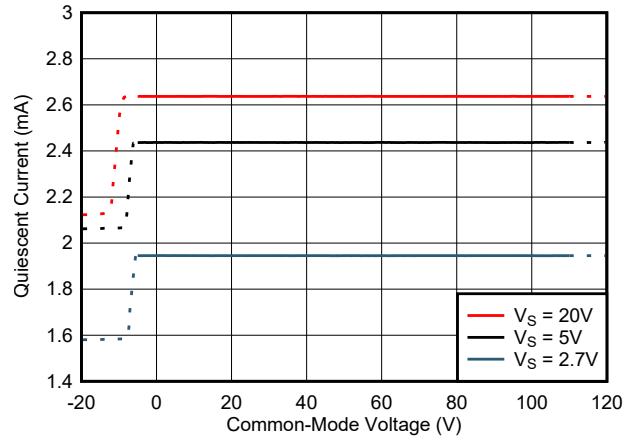
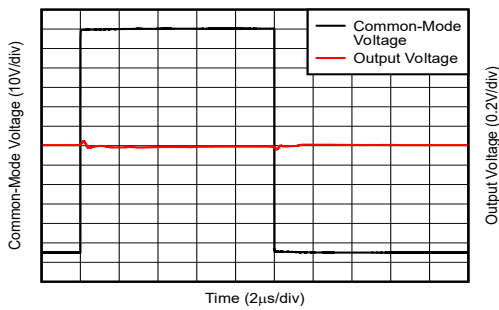

Figure 6-32. Quiescent Current vs Common-Mode Voltage



$V_{\text{CM}} = -5\text{V to } 110\text{V}$,
 $V_{\text{SENSE}} = 0\text{V}$

Figure 6-33. Common-Mode Voltage Fast Transient Pulse

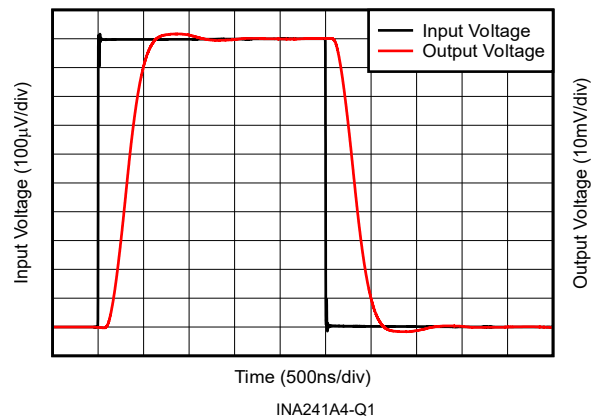

Figure 6-34. Small Step Response

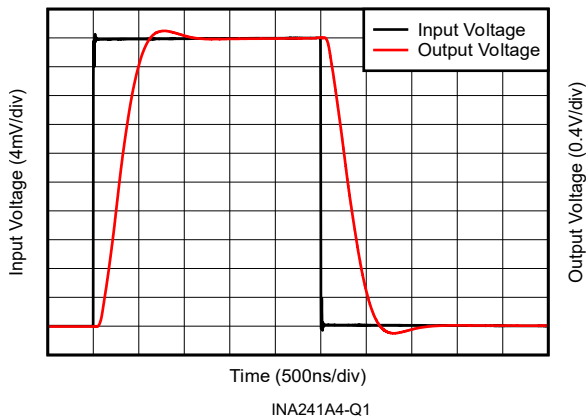

Figure 6-35. Large Step Response

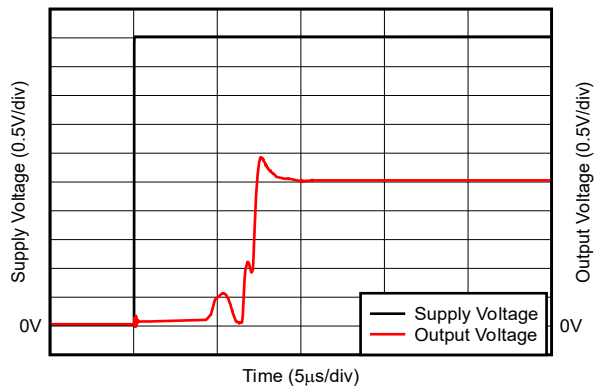
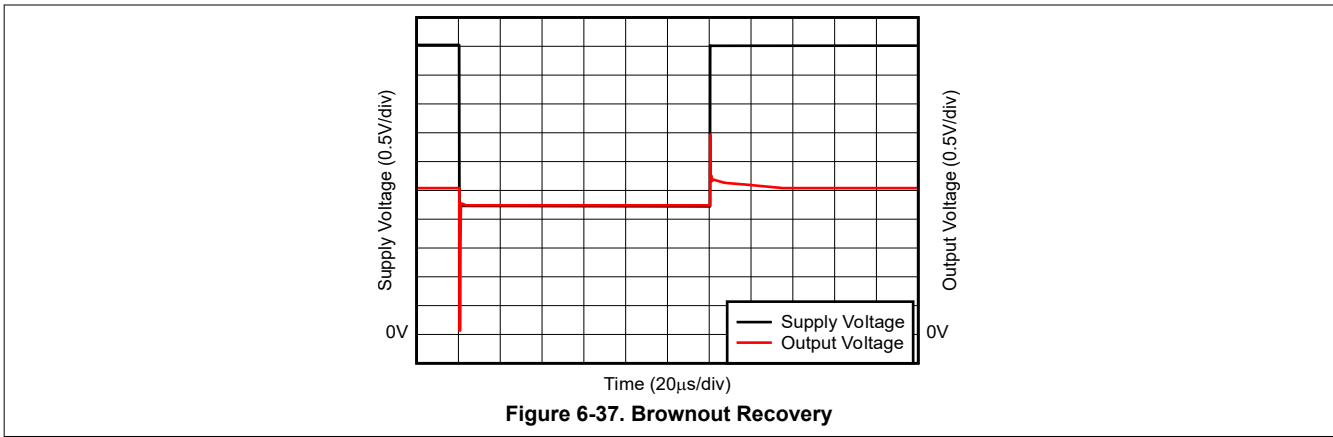

Figure 6-36. Start-Up Response

6.6 Typical Characteristics (continued)

at $T_A = 25^\circ\text{C}$, $V_S = 5\text{V}$, $V_{\text{SENSE}} = V_{\text{IN}+} - V_{\text{IN}-}$, $V_{\text{CM}} = V_{\text{IN}-} = 48\text{V}$, and $V_{\text{REF1}} = V_{\text{REF2}} = V_S / 2$ (unless otherwise noted)



7 Detailed Description

7.1 Overview

The INA241x-Q1 is a high-side, inline, or low-side bidirectional, high-speed current-sense amplifier that offers a wide common-mode range, precision, zero-drift topology, excellent common-mode rejection ratio (CMRR), and features enhanced pulse width modulation (PWM) rejection at the inputs of the device. Enhanced PWM rejection reduces the effect of common-mode transients that can propagate to the output signal that are associated with PWM input signals. Multiple gain versions are available to allow for the optimization of the desired full-scale output voltage based on the target current range expected in the application.

7.2 Functional Block Diagram

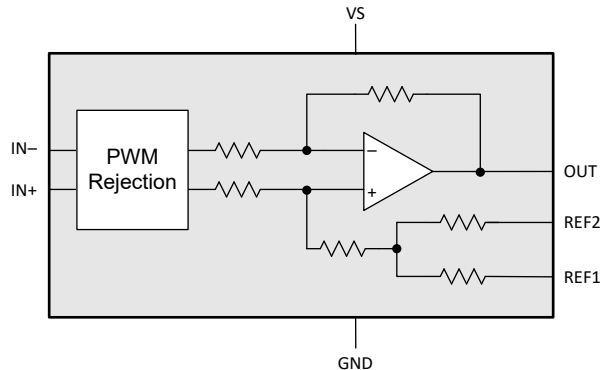

7.3 Feature Description

7.3.1 Amplifier Input Common-Mode Signal

The INA241x-Q1 supports large input common-mode voltages from -5V to 110V . The internal topology of the INA241x-Q1 allows the common-mode range to exceed the power-supply voltage (V_S). This allows for the INA241x-Q1 to be used for low-side, inline, and high-side current-sensing applications that extend beyond the supply range of 2.7V to 20V .

7.3.1.1 Enhanced PWM Rejection Operation

The enhanced PWM rejection feature of the INA241x-Q1 provides increased attenuation of large common-mode $\Delta V/\Delta t$ transients. Large $\Delta V/\Delta t$ common-mode transients associated with PWM signals are employed in applications such as motor or solenoid drive and switching power supplies. The disturbances that can occur at the output of a current sense amplifier from common-mode transients causes erroneous measurements and impose limitations when the output is valid. The INA241x-Q1 is designed with high common-mode rejection techniques to reduce large $\Delta V/\Delta t$ transients before the system is disturbed. As a result, this makes system design simple with INA241x-Q1. The high AC CMRR, in conjunction with signal bandwidth, allows the INA241x-Q1 to minimize output disturbances and ringing during common-mode transitions when compared against traditional current-sensing amplifiers.

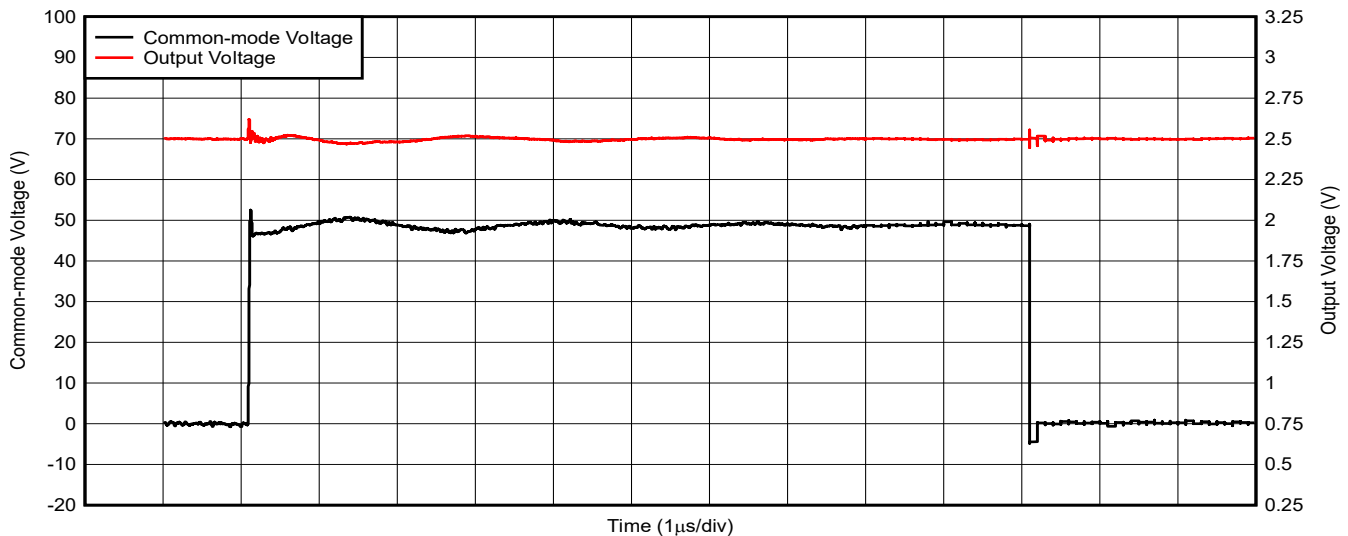

Figure 7-1. Enhanced PWM Rejection Performance

Figure 7-1 shows the INA241x-Q1 PWM enhancement performance. When INA241x-Q1 senses the large common-mode $\Delta V/\Delta t$ transients, the device holds the output for $1\mu\text{s}$, thereby preventing the common-mode disturbance from propagating to the output. If another common-mode transient occurs during the following $3\mu\text{s}$, the INA241x-Q1 relies on high BW and AC CMMR to attenuate the effect of common-mode transient. The enhanced PWM rejection is achieved up to a PWM frequency of 125kHz or if common-mode transient edges are separated by a $3\mu\text{s}$ interval or more.

7.3.1.2 Input-Signal Bandwidth

The INA241x-Q1 is available with several gain options including 10V/V, 20V/V, 50V/V, 100V/V, and 200V/V. The unique multistage design enables the amplifier to achieve high bandwidth of 1.1MHz at all gains. This high bandwidth provides the throughput and fast response that is required for the rapid detection and processing of over-current events.

7.3.1.3 Low Input Bias Current

The INA241x-Q1 inputs draw $35\mu\text{A}$ (typical) bias current per input pin at common-mode voltages as high as 110V, which enables precision current sensing on applications that require lower current leakage. Unlike many high voltage current sense amplifiers whose input bias currents are proportional to the common-mode voltage, the input bias current of the INA241x-Q1 remains constant over the entire common-mode voltage range.

7.3.1.4 Low V_{SENSE} Operation

The INA241x-Q1 features high performance operation across the entire valid V_{SENSE} range. The zero-drift input architecture of the INA241x-Q1 provides the low offset voltage and low offset drift needed to measure low V_{SENSE} levels accurately across the wide operating temperature of -40°C to $+125^{\circ}\text{C}$. Low V_{SENSE} operation is particularly beneficial when using low ohmic shunts for low current measurements, as power losses across the shunt are significantly reduced.

7.3.1.5 Wide Fixed Gain Output

The INA241x-Q1 maximum gain error is $\pm 0.01\%$ at room temperature, with a maximum drift of ± 1 ppm/ $^{\circ}\text{C}$ over the full temperature range of -40°C to 125°C . The INA241x-Q1 is available in multiple gain options of 10V/V, 20V/V, 50V/V, 100V/V, and 200V/V, which the system designer must select based on the desired signal-to-noise ratio and other system requirements, such as the dynamic current range and full-scale output voltage target.

7.3.1.6 Wide Supply Range

The INA241x-Q1 operates with a wide supply range from 2.7V to 20V. While the input common-mode voltage range of the INA241x-Q1 is independent of the supply voltage, the output voltage is bound by the supply voltage

applied to the device. The output voltage can range from as low as 20mV to as high as 200mV below the supply voltage.

7.4 Device Functional Modes

7.4.1 Adjusting the Output With the Reference Pins

Figure 7-2 shows a test circuit for reference-divider accuracy. The INA241x-Q1 output is configurable to allow for unidirectional or bidirectional operation.

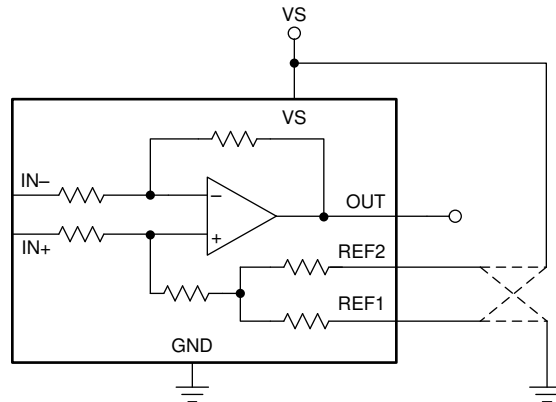

Figure 7-2. Test Circuit For Reference Divider Accuracy

The output voltage is set by applying a voltage or voltages to the reference voltage inputs, REF1 and REF2. The reference inputs are connected to an internal gain network. There is no operational difference between the two reference pins. The resistor network connected to the two reference pins are designed with ultra-precision and matching. Output is set accurately at the mid-point voltage between the voltages applied to reference voltage inputs, when current-sense input voltage is 0V as shown in Equation 1. In most bidirectional applications, one reference input is connected to the positive supply and the other reference input is connected to the negative supply (GND pin) to set the output voltage to mid-supply.

$$V_{OUT} = G \times (V_{IN+} - V_{IN-}) + \frac{V_{REF1} + V_{REF2}}{2} \quad (1)$$

7.4.2 Reference Pin Connections for Unidirectional Current Measurements

Unidirectional operation allows current measurements through a resistive shunt in one direction. For unidirectional operation, connect the device reference pins together and then to the negative rail (see the [Ground Referenced Output](#) section) or the positive rail (see the [VS Referenced Output](#) section). The required differential input polarity depends on the reference input setting. The amplifier output moves away from the referenced rail proportional to the current passing through the external shunt resistor. If the amplifier reference pins are connected to the positive rail, then the input polarity must be negative to move the amplifier output down (towards ground). If the amplifier reference pins are connected to ground, then the input polarity must be positive to move the amplifier output up (towards supply).

The following sections describe how to configure the output for unidirectional operation cases.

7.4.2.1 Ground Referenced Output

When using the INA241x-Q1 in a unidirectional mode with a ground referenced output, both reference inputs are connected to ground. This configuration takes the output to ground when there is a 0V differential at the input (see [Figure 7-3](#)).

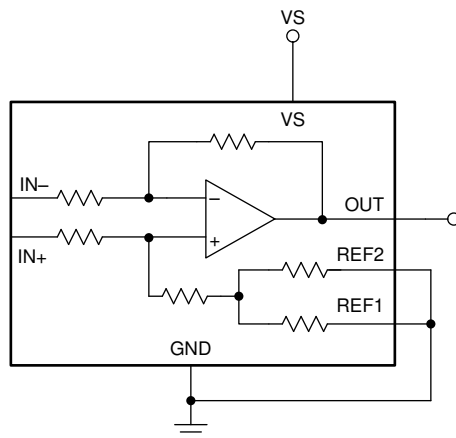

Figure 7-3. Ground Referenced Output

7.4.2.2 VS Referenced Output

Unidirectional mode with a VS referenced output is configured by connecting both reference pins to the positive supply. Use this configuration for circuits that require power up and stabilization of the amplifier output signal and other control circuitry before power is applied to the load (see [Figure 7-4](#)).

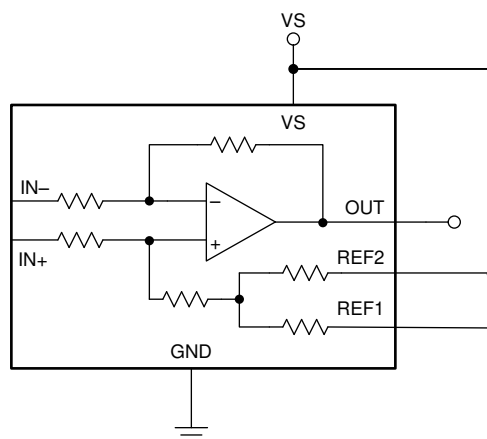

Figure 7-4. VS Referenced Output

7.4.3 Reference Pin Connections for Bidirectional Current Measurements

The INA241x-Q1 measures the differential voltage developed by current flowing through a resistor, commonly referred to as a current-sensing resistor or a current-shunt resistor. The INA241x-Q1 can operate in either a unidirectional or bidirectional mode based on the voltage potential placed on the reference pins.

The linear range of the output stage is limited to how close the output voltage can approach ground as well the supply voltage as described in the [Specifications](#). The selection of the current-sensing resistor along with the current range to be measured, selection of the gain option, as well as the voltage applied to the reference pins must be selected to keep the INA241x-Q1 within the linear region of operation.

7.4.3.1 Output Set to External Reference Voltage

Connecting both pins together and then to a reference voltage results in an output voltage equal to the reference voltage for the condition of shorted input pins or a 0V differential input. [Figure 7-5](#) shows this configuration. The output voltage decreases below the reference voltage when the IN+ pin is negative relative to the IN- pin and increases when the IN+ pin is positive relative to the IN- pin. This technique is the most accurate way to bias the output to a precise voltage.

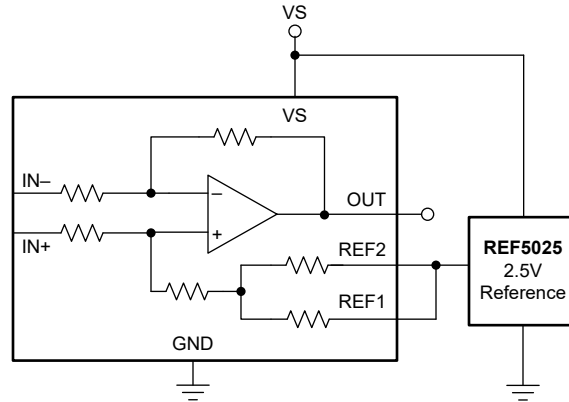

Figure 7-5. External Reference Output

7.4.3.2 Output Set to Mid-Supply Voltage

By connecting one reference pin to VS and the other to the GND pin, [Figure 7-6](#) shows that the output is set at half of the supply voltage when there is no differential input. This method creates a ratiometric offset to the supply voltage, where the output voltage remains at $VS / 2$ for 0V applied to the inputs.

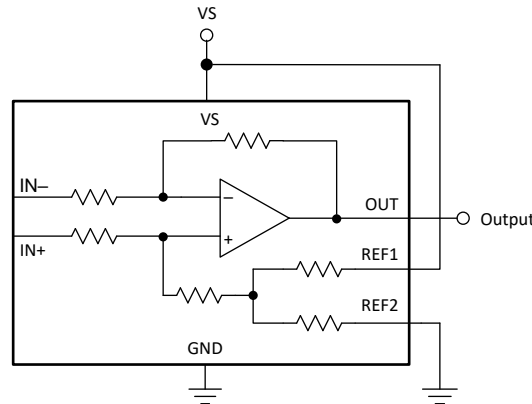

Figure 7-6. Mid-Supply Voltage Output

7.4.3.3 Output Set to Mid-External Reference

In this case, [Figure 7-7](#) shows how an external reference can be divided by two by connecting one REF pin to ground and the other REF pin to the reference.

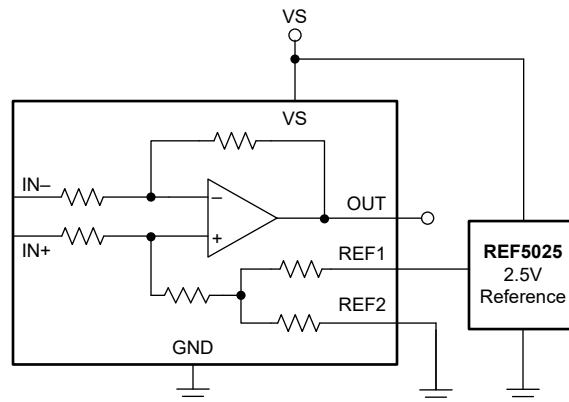

Figure 7-7. Mid-External Reference Output

7.4.3.4 Output Set Using Resistor Divider

The INA241x-Q1 reference pins allow for the mid-point of the output voltage to be adjusted for system circuitry connections to analog to digital converters (ADCs) or other amplifiers. The reference pins are designed to be connected directly to supply, ground, or a low-impedance reference voltage. The reference pins can be connected together and biased using a resistor divider to achieve a custom output voltage. If the amplifier is used in this configuration, as shown in Figure 7-8, use the output as a differential signal with respect to the resistor divider voltage. Use of the amplifier output as a single-ended signal in this configuration is not recommended because the internal impedance shifts can adversely affect device performance specifications. If single-ended measurement is required, TI recommends to use an external op amp to buffer the resistor divider voltage (see Figure 7-9).

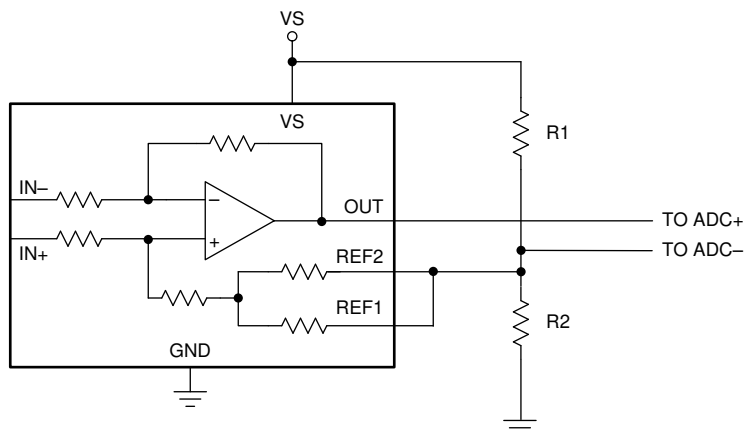

Figure 7-8. Setting the Reference Using a Resistor Divider

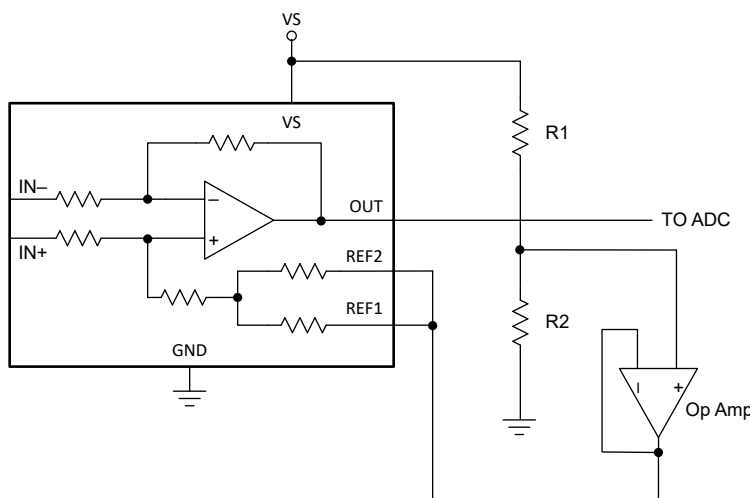

Figure 7-9. Setting the Reference Using a Resistor Divider and an Op Amp Buffer

7.4.4 High Signal Throughput

With a bandwidth of 1.1MHz at a gain of 20V/V and a slew rate of 8V/μs, the INA241x-Q1 is specifically designed for detecting and protecting applications from fast inrush currents. As shown in Table 7-1, the INA241x-Q1 responds in less than 1μs for a system measuring a 75A threshold on a 2mΩ shunt.

Table 7-1. Response Time

PARAMETER		EQUATION	INA241x-Q1 AT V _S = 5V
G	Gain		20V/V
I _{MAX}	Maximum current		100A

Table 7-1. Response Time (continued)

PARAMETER		EQUATION	INA241x-Q1 AT $V_S = 5V$
$I_{\text{Threshold}}$	Threshold current		75A
R_{SENSE}	Current sense resistor value		2m Ω
$V_{\text{OUT_MAX}}$	Output voltage at maximum current	$V_{\text{OUT_MAX}} = I_{\text{MAX}} \times R_{\text{SENSE}} \times G$	4V
$V_{\text{OUT_THR}}$	Output voltage at threshold current	$V_{\text{OUT_THR}} = I_{\text{THR}} \times R_{\text{SENSE}} \times G$	3V
SR	Slew rate		8V/ μs
T_{response}	Output response time	$T_{\text{response}} = V_{\text{OUT_THR}} / \text{SR}$	< 1 μs

8 Application and Implementation

Note

Information in the following applications sections is not part of the TI component specification, and TI does not warrant its accuracy or completeness. TI's customers are responsible for determining suitability of components for their purposes, as well as validating and testing their design implementation to confirm system functionality.

8.1 Application Information

The INA241x-Q1 amplifies the voltage developed across a current-sensing resistor as current flows through the resistor to the load. The wide input common-mode voltage range and high common-mode rejection of the INA241x-Q1 make the device usable over a wide range of voltage rails while still maintaining an accurate current measurement.

8.1.1 R_{SENSE} and Device Gain Selection

The accuracy of any current-sense amplifier is maximized by choosing the largest current-sense resistor value possible. A larger value sense resistor maximizes the differential input signal for a given amount of current flow and reduces the error contribution of the offset voltage. However, there are practical limits as to how large the current-sense resistor value can be in a given application because of the physical dimensions of the package, package construction, and maximum power dissipation. Equation 2 gives the maximum value for the current-sense resistor for a given power dissipation budget:

$$R_{SENSE} < \frac{PD_{MAX}}{I_{MAX}^2} \quad (2)$$

where:

- PD_{MAX} is the maximum allowable power dissipation in R_{SENSE} .
- I_{MAX} is the maximum current that flows through R_{SENSE} .

An additional limitation on the size of the current-sense resistor and device gain is due to the power-supply voltage, V_S , and device swing-to-rail limitations. To make sure that the current-sense signal is properly passed to the output, both positive and negative output swing limitations must be examined. Equation 3 provides the maximum values of R_{SENSE} and GAIN to keep the device from exceeding the positive swing limitation.

$$I_{MAX} \times R_{SENSE} \times GAIN < V_{SP} \quad (3)$$

where:

- I_{MAX} is the maximum current that flows through R_{SENSE} .
- GAIN is the gain of the current-sense amplifier.
- V_{SP} is the positive output swing of the device as specified in the [Specifications](#).

To avoid positive output swing limitations when selecting the value of R_{SENSE} , there is always a trade-off between the value of the sense resistor and the gain of the device under consideration. If the sense resistor selected for the maximum power dissipation is too large, then selecting a lower gain device is possible to avoid positive swing limitations.

The negative swing limitation places a limit on how small the sense resistor value can be for a given application. Equation 4 provides the limit on the minimum value of the sense resistor.

$$I_{MIN} \times R_{SENSE} \times GAIN > V_{SN} \quad (4)$$

where:

- I_{MIN} is the minimum current that flows through R_{SENSE} .
- GAIN is the gain of the current-sense amplifier.
- V_{SN} is the negative output swing of the device as specified in the [Specifications](#).

Table 8-1 shows an example of the different results obtained from using five different gain versions of the INA241x-Q1. From the table data, the highest gain device allows a smaller current-shunt resistor and decreased power dissipation in the element.

Table 8-1. R_{SENSE} Selection and Power Dissipation (1)

PARAMETER		EQUATION	RESULTS AT $V_S = 5V$				
			A1, B1 DEVICES	A2, B2 DEVICES	A3, B3 DEVICES	A4, B4 DEVICES	A5, B5 DEVICES
G	Gain		10V/V	20V/V	50V/V	100V/V	200V/V
V_{SENSE}	Ideal differential input voltage	$V_{SENSE} = V_{OUT} / G$	500mV	250mV	100mV	50mV	25mV
R_{SENSE}	Current sense resistor value	$R_{SENSE} = V_{SENSE} / I_{MAX}$	50m Ω	25m Ω	10m Ω	5m Ω	2.5m Ω
P_{SENSE}	Current-sense resistor power dissipation	$R_{SENSE} \times I_{MAX}^2$	5W	2.5W	1W	0.5W	0.25W

(1) Design example with 10A full-scale current with maximum output voltage set to 5V.

8.2 Typical Application

The INA241x-Q1 is a bidirectional, current-sense amplifier capable of measuring currents through a resistive shunt with common-mode voltages from $-5V$ to $+110V$.

8.2.1 Inline Motor Current-Sense Application

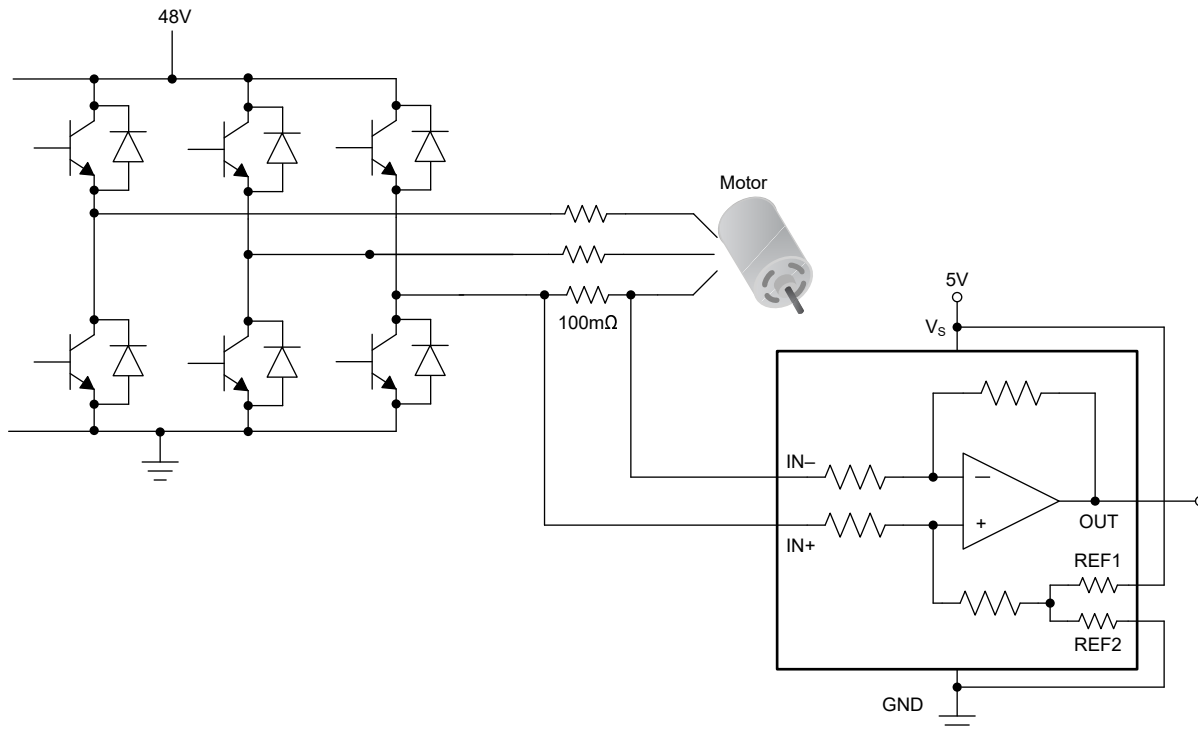

Figure 8-1. Inline Motor Application Circuit

8.2.1.1 Design Requirements

Inline current sensing has many advantages in motor control, from torque ripple reduction to real-time motor health monitoring. However, the full-scale PWM voltage requirements for inline current measurements provide challenges to accurately measure the current. Switching frequencies in the 50kHz to 100kHz range create higher $\Delta V/\Delta t$ signal transitions that must be addressed to obtain accurate inline current measurements.

With a superior common-mode rejection capability, high precision, and a high common-mode specification, the INA241x-Q1 provides performance for a wide range of common-mode voltages.

8.2.1.2 Detailed Design Procedure

For this application, the INA241x-Q1 measures current in the drive circuitry of a 48V, 4000 RPM motor.

To demonstrate the performance of the device, the INA241A2-Q1 with a gain of 20V/V is selected for this design and powered from a 5V supply.

Using the information in the [Section 7.4.3.2](#) section, the reference point is set to mid-scale by splitting the supply with REF1 connected to supply and REF2 connected to ground. This configuration allows for bipolar current measurements. Alternatively, the reference pins can be tied together and driven with an external precision reference.

The current-sensing resistor is sized so that the output of the INA241x-Q1 is not saturated. A value of 100mΩ is selected to maintain the analog input within the device limits.

8.2.1.3 Application Curve

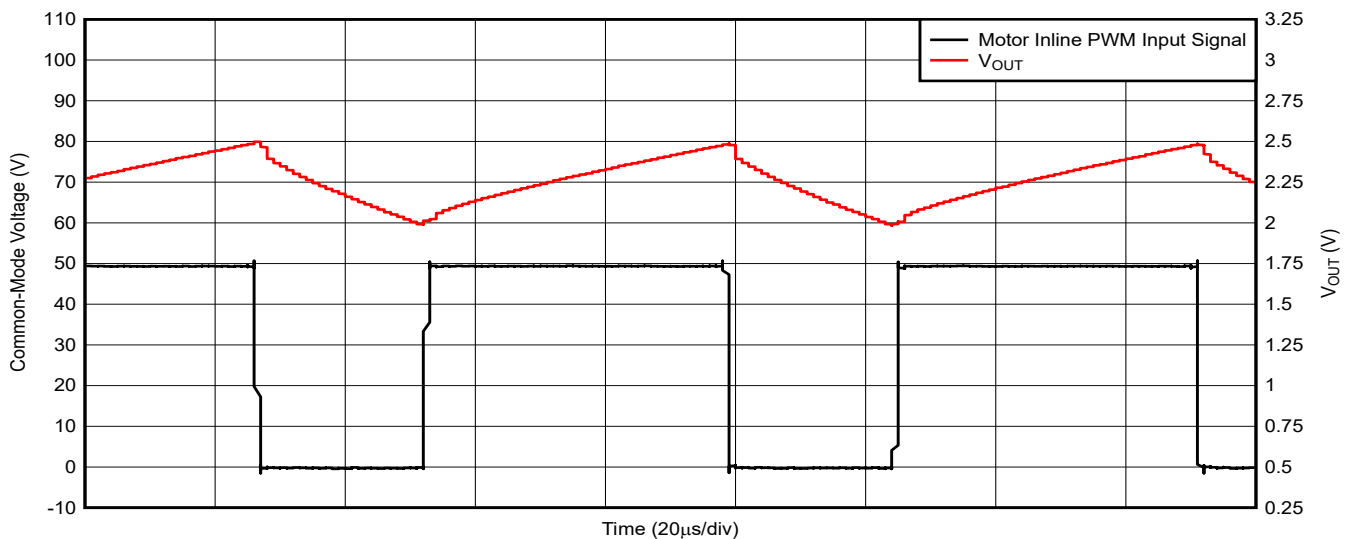

Figure 8-2. INA241A2-Q1 Inline Motor Current-Sense Input and Output Signals

8.3 Power Supply Recommendations

The INA241x-Q1 makes accurate measurements beyond the connected power-supply voltage (V_S) because the inputs (IN+ and IN-) can operate anywhere between $-5V$ and $110V$ independent of V_S . For example, with the V_S power supply equal to $5V$, the common-mode voltage of the measured shunt can be as high as $110V$.

8.3.1 Power Supply Decoupling

Place the power-supply bypass capacitor as close to the supply and ground pins as possible. TI recommends a bypass capacitor value of $0.1\mu F$. Additional decoupling capacitance can be added to compensate for noisy or high-impedance power supplies.

8.4 Layout

8.4.1 Layout Guidelines

Attention to good layout practices is always recommended.

- Connect the input pins to the sensing resistor using a Kelvin or 4-wire connection. This connection technique makes sure that only the current-sensing resistor impedance is detected between the input pins. Poor routing of the current-sensing resistor commonly results in additional resistance present between the input pins.

Given the very low ohmic value of the current sense resistor, any additional high-current carrying impedance can cause significant measurement errors.

- Place the power-supply bypass capacitor as close to the device power supply and ground pins as possible. The recommended value of this bypass capacitor is 0.1 μF . Additional decoupling capacitance can be added to compensate for noisy or high-impedance power supplies.

8.4.2 Layout Examples

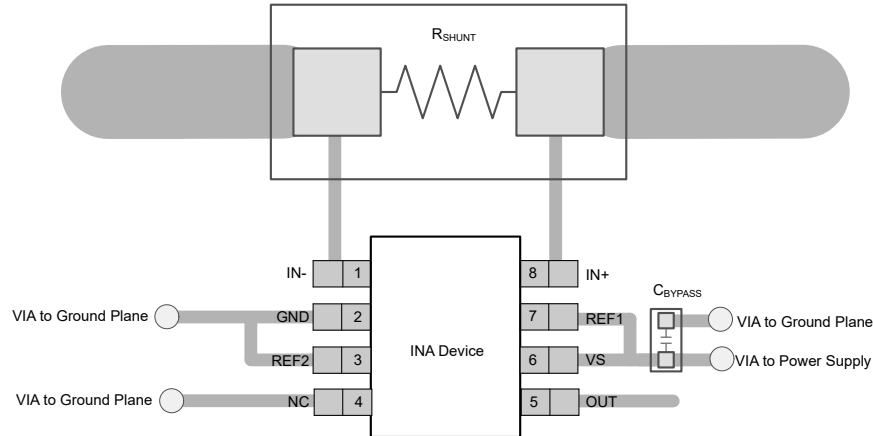

Figure 8-3. INA241x-Q1 SOT-23 (DDF), SOIC (D) and VSSOP (DGK) Package Recommended Layout

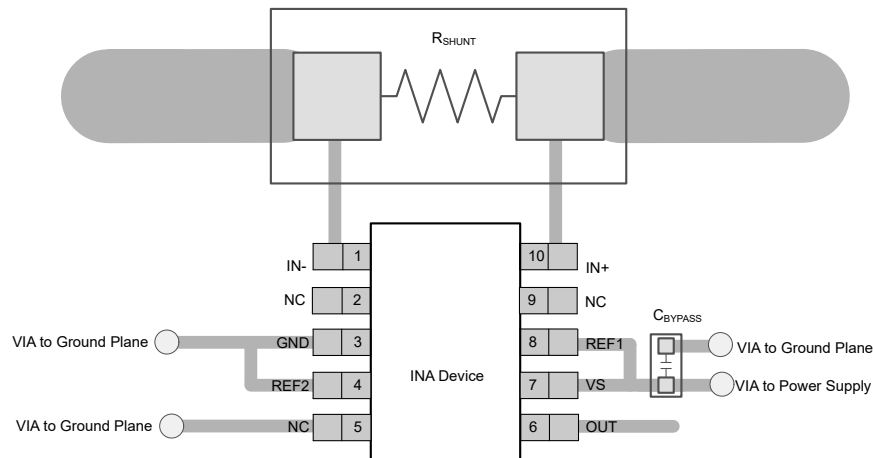

Figure 8-4. INA241x-Q1 10-Pin VSSOP (DGS) Package Recommended Layout

9 Device and Documentation Support

9.1 Documentation Support

9.1.1 Related Documentation

For related documentation see the following: Texas Instruments, [INA296EVM](#), EVM user's guide

9.2 Receiving Notification of Documentation Updates

To receive notification of documentation updates, navigate to the device product folder on ti.com. In the upper right corner, click on *Alert me* to register and receive a weekly digest of any product information that has changed. For change details, review the revision history included in any revised document.

9.3 Support Resources

[TI E2E™ support forums](#) are an engineer's go-to source for fast, verified answers and design help — straight from the experts. Search existing answers or ask your own question to get the quick design help you need.

Linked content is provided "AS IS" by the respective contributors. They do not constitute TI specifications and do not necessarily reflect TI's views; see TI's [Terms of Use](#).

9.4 Trademarks

TI E2E™ is a trademark of Texas Instruments.

All trademarks are the property of their respective owners.

9.5 Electrostatic Discharge Caution



This integrated circuit can be damaged by ESD. Texas Instruments recommends that all integrated circuits be handled with appropriate precautions. Failure to observe proper handling and installation procedures can cause damage.

ESD damage can range from subtle performance degradation to complete device failure. Precision integrated circuits may be more susceptible to damage because very small parametric changes could cause the device not to meet its published specifications.

9.6 Glossary

[TI Glossary](#) This glossary lists and explains terms, acronyms, and definitions.

10 Revision History

NOTE: Page numbers for previous revisions may differ from page numbers in the current version.

Changes from Revision B (March 2024) to Revision C (December 2024)	Page
• Updated the number format for tables, figures, and cross-references throughout the document.....	1
• Deleted the preview note from DGS package from <i>Package Information</i> table and throughout the data sheet	1

Changes from Revision A (August 2023) to Revision B (March 2024)	Page
• Updated the number format for tables, figures, and cross-references throughout the document.....	1
• Deleted the preview note from D package from <i>Package Information</i> table and throughout the data sheet.....	1
• Deleted the preview note about D package information.....	2

Changes from Revision * (February 2023) to Revision A (August 2023)	Page
• Added the DGS package to the data sheet.....	1
• Changed package information from body size to package size.....	1
• Deleted preview note from DGK package from package information table.....	1
• Added the DGS package pin configuration.....	2

-
- Added DGS package in recommended layout examples.....25
-

11 Mechanical, Packaging, and Orderable Information

The following pages include mechanical, packaging, and orderable information. This information is the most current data available for the designated devices. This data is subject to change without notice and revision of this document. For browser-based versions of this data sheet, refer to the left-hand navigation.

PACKAGING INFORMATION

Orderable Device	Status (1)	Package Type	Package Drawing	Pins	Package Qty	Eco Plan (2)	Lead finish/ Ball material (6)	MSL Peak Temp (3)	Op Temp (°C)	Device Marking (4/5)	Samples
INA241A1QDDFRQ1	ACTIVE	SOT-23-THIN	DDF	8	3000	RoHS & Green	NIPDAU	Level-1-260C-UNLIM	-40 to 125	2ZN3	Samples
INA241A1QDGRQ1	ACTIVE	VSSOP	DGK	8	2500	RoHS & Green	NIPDAU	Level-2-260C-1 YEAR	-40 to 125	39VB	Samples
INA241A1QDRQ1	ACTIVE	SOIC	D	8	2500	RoHS & Green	NIPDAU	Level-2-260C-1 YEAR	-40 to 125	241A1Q	Samples
INA241A2QDDFRQ1	ACTIVE	SOT-23-THIN	DDF	8	3000	RoHS & Green	NIPDAU	Level-1-260C-UNLIM	-40 to 125	2ZO3	Samples
INA241A2QDGRQ1	ACTIVE	VSSOP	DGK	8	2500	RoHS & Green	NIPDAU	Level-2-260C-1 YEAR	-40 to 125	39WB	Samples
INA241A2QDRQ1	ACTIVE	SOIC	D	8	2500	RoHS & Green	NIPDAU	Level-2-260C-1 YEAR	-40 to 125	241A2Q	Samples
INA241A3QDDFRQ1	ACTIVE	SOT-23-THIN	DDF	8	3000	RoHS & Green	NIPDAU	Level-1-260C-UNLIM	-40 to 125	2ZP3	Samples
INA241A3QDGRQ1	ACTIVE	VSSOP	DGK	8	2500	RoHS & Green	NIPDAU	Level-2-260C-1 YEAR	-40 to 125	39XB	Samples
INA241A3QDRQ1	ACTIVE	SOIC	D	8	2500	RoHS & Green	NIPDAU	Level-2-260C-1 YEAR	-40 to 125	241A3Q	Samples
INA241A4QDDFRQ1	ACTIVE	SOT-23-THIN	DDF	8	3000	RoHS & Green	NIPDAU	Level-1-260C-UNLIM	-40 to 125	2ZQ3	Samples
INA241A4QDGRQ1	ACTIVE	VSSOP	DGK	8	2500	RoHS & Green	NIPDAU	Level-2-260C-1 YEAR	-40 to 125	39ZB	Samples
INA241A4QDRQ1	ACTIVE	SOIC	D	8	2500	RoHS & Green	NIPDAU	Level-2-260C-1 YEAR	-40 to 125	241A4Q	Samples
INA241A5QDDFRQ1	ACTIVE	SOT-23-THIN	DDF	8	3000	RoHS & Green	NIPDAU	Level-1-260C-UNLIM	-40 to 125	2ZR3	Samples
INA241A5QDGRQ1	ACTIVE	VSSOP	DGK	8	2500	RoHS & Green	NIPDAU	Level-2-260C-1 YEAR	-40 to 125	3A1B	Samples
INA241A5QDRQ1	ACTIVE	SOIC	D	8	2500	RoHS & Green	NIPDAU	Level-2-260C-1 YEAR	-40 to 125	241A5Q	Samples
INA241B1QDDFRQ1	ACTIVE	SOT-23-THIN	DDF	8	3000	RoHS & Green	NIPDAU	Level-1-260C-UNLIM	-40 to 125	2ZS3	Samples
INA241B1QDGRQ1	ACTIVE	VSSOP	DGK	8	2500	RoHS & Green	NIPDAU	Level-2-260C-1 YEAR	-40 to 125	3A2B	Samples
INA241B1QDRQ1	ACTIVE	SOIC	D	8	2500	RoHS & Green	NIPDAU	Level-2-260C-1 YEAR	-40 to 125	241B1Q	Samples
INA241B2QDDFRQ1	ACTIVE	SOT-23-THIN	DDF	8	3000	RoHS & Green	NIPDAU	Level-1-260C-UNLIM	-40 to 125	2ZT3	Samples
INA241B2QDGRQ1	ACTIVE	VSSOP	DGK	8	2500	RoHS & Green	NIPDAU	Level-2-260C-1 YEAR	-40 to 125	3A3B	Samples

Orderable Device	Status (1)	Package Type	Package Drawing	Pins	Package Qty	Eco Plan (2)	Lead finish/ Ball material (6)	MSL Peak Temp (3)	Op Temp (°C)	Device Marking (4/5)	Samples
INA241B2QDRQ1	ACTIVE	SOIC	D	8	2500	RoHS & Green	NIPDAU	Level-2-260C-1 YEAR	-40 to 125	241B2Q	Samples
INA241B3QDDFRQ1	ACTIVE	SOT-23-THIN	DDF	8	3000	RoHS & Green	NIPDAU	Level-1-260C-UNLIM	-40 to 125	2ZU3	Samples
INA241B3QDGKRQ1	ACTIVE	VSSOP	DGK	8	2500	RoHS & Green	NIPDAU	Level-2-260C-1 YEAR	-40 to 125	3A3B	Samples
INA241B3QDRQ1	ACTIVE	SOIC	D	8	2500	RoHS & Green	NIPDAU	Level-2-260C-1 YEAR	-40 to 125	241B3Q	Samples
INA241B4QDDFRQ1	ACTIVE	SOT-23-THIN	DDF	8	3000	RoHS & Green	NIPDAU	Level-1-260C-UNLIM	-40 to 125	2ZV3	Samples
INA241B4QDGKRQ1	ACTIVE	VSSOP	DGK	8	2500	RoHS & Green	NIPDAU	Level-2-260C-1 YEAR	-40 to 125	3A5B	Samples
INA241B4QDRQ1	ACTIVE	SOIC	D	8	2500	RoHS & Green	NIPDAU	Level-2-260C-1 YEAR	-40 to 125	241B4Q	Samples
INA241B5QDDFRQ1	ACTIVE	SOT-23-THIN	DDF	8	3000	RoHS & Green	NIPDAU	Level-1-260C-UNLIM	-40 to 125	2ZW3	Samples
INA241B5QDGKRQ1	ACTIVE	VSSOP	DGK	8	2500	RoHS & Green	NIPDAU	Level-2-260C-1 YEAR	-40 to 125	3A6B	Samples
INA241B5QDRQ1	ACTIVE	SOIC	D	8	2500	RoHS & Green	NIPDAU	Level-2-260C-1 YEAR	-40 to 125	241B5Q	Samples

(1) The marketing status values are defined as follows:

ACTIVE: Product device recommended for new designs.

LIFEBUY: TI has announced that the device will be discontinued, and a lifetime-buy period is in effect.

NRND: Not recommended for new designs. Device is in production to support existing customers, but TI does not recommend using this part in a new design.

PREVIEW: Device has been announced but is not in production. Samples may or may not be available.

OBSELETE: TI has discontinued the production of the device.

(2) **RoHS:** TI defines "RoHS" to mean semiconductor products that are compliant with the current EU RoHS requirements for all 10 RoHS substances, including the requirement that RoHS substance do not exceed 0.1% by weight in homogeneous materials. Where designed to be soldered at high temperatures, "RoHS" products are suitable for use in specified lead-free processes. TI may reference these types of products as "Pb-Free".

RoHS Exempt: TI defines "RoHS Exempt" to mean products that contain lead but are compliant with EU RoHS pursuant to a specific EU RoHS exemption.

Green: TI defines "Green" to mean the content of Chlorine (Cl) and Bromine (Br) based flame retardants meet JS709B low halogen requirements of <=1000ppm threshold. Antimony trioxide based flame retardants must also meet the <=1000ppm threshold requirement.

(3) MSL, Peak Temp. - The Moisture Sensitivity Level rating according to the JEDEC industry standard classifications, and peak solder temperature.

(4) There may be additional marking, which relates to the logo, the lot trace code information, or the environmental category on the device.

(5) Multiple Device Markings will be inside parentheses. Only one Device Marking contained in parentheses and separated by a "~" will appear on a device. If a line is indented then it is a continuation of the previous line and the two combined represent the entire Device Marking for that device.

(6) Lead finish/Ball material - Orderable Devices may have multiple material finish options. Finish options are separated by a vertical ruled line. Lead finish/Ball material values may wrap to two lines if the finish value exceeds the maximum column width.

Important Information and Disclaimer:The information provided on this page represents TI's knowledge and belief as of the date that it is provided. TI bases its knowledge and belief on information provided by third parties, and makes no representation or warranty as to the accuracy of such information. Efforts are underway to better integrate information from third parties. TI has taken and continues to take reasonable steps to provide representative and accurate information but may not have conducted destructive testing or chemical analysis on incoming materials and chemicals. TI and TI suppliers consider certain information to be proprietary, and thus CAS numbers and other limited information may not be available for release.

In no event shall TI's liability arising out of such information exceed the total purchase price of the TI part(s) at issue in this document sold by TI to Customer on an annual basis.

OTHER QUALIFIED VERSIONS OF INA241A-Q1, INA241B-Q1 :

- Catalog : [INA241A](#), [INA241B](#)

NOTE: Qualified Version Definitions:

- Catalog - TI's standard catalog product

TAPE AND REEL INFORMATION

QUADRANT ASSIGNMENTS FOR PIN 1 ORIENTATION IN TAPE

*All dimensions are nominal

Device	Package Type	Package Drawing	Pins	SPQ	Reel Diameter (mm)	Reel Width W1 (mm)	A0 (mm)	B0 (mm)	K0 (mm)	P1 (mm)	W (mm)	Pin1 Quadrant
INA241A1QDDFRQ1	SOT-23-THIN	DDF	8	3000	180.0	8.4	3.2	3.2	1.4	4.0	8.0	Q3
INA241A1QDGKRQ1	VSSOP	DGK	8	2500	330.0	12.4	5.3	3.4	1.4	8.0	12.0	Q1
INA241A1QDRQ1	SOIC	D	8	2500	330.0	12.4	6.4	5.2	2.1	8.0	12.0	Q1
INA241A2QDDFRQ1	SOT-23-THIN	DDF	8	3000	180.0	8.4	3.2	3.2	1.4	4.0	8.0	Q3
INA241A2QDDFRQ1	SOT-23-THIN	DDF	8	3000	180.0	8.4	3.15	3.1	1.55	4.0	8.0	Q3
INA241A2QDGKRQ1	VSSOP	DGK	8	2500	330.0	12.4	5.3	3.4	1.4	8.0	12.0	Q1
INA241A2QDRQ1	SOIC	D	8	2500	330.0	12.4	6.4	5.2	2.1	8.0	12.0	Q1
INA241A3QDDFRQ1	SOT-23-THIN	DDF	8	3000	180.0	8.4	3.2	3.2	1.4	4.0	8.0	Q3
INA241A3QDDFRQ1	SOT-23-THIN	DDF	8	3000	180.0	8.4	3.15	3.1	1.55	4.0	8.0	Q3
INA241A3QDGKRQ1	VSSOP	DGK	8	2500	330.0	12.4	5.3	3.4	1.4	8.0	12.0	Q1
INA241A3QDRQ1	SOIC	D	8	2500	330.0	12.4	6.4	5.2	2.1	8.0	12.0	Q1
INA241A4QDDFRQ1	SOT-23-THIN	DDF	8	3000	180.0	8.4	3.2	3.2	1.4	4.0	8.0	Q3

Device	Package Type	Package Drawing	Pins	SPQ	Reel Diameter (mm)	Reel Width W1 (mm)	A0 (mm)	B0 (mm)	K0 (mm)	P1 (mm)	W (mm)	Pin1 Quadrant
INA241A4QDDFRQ1	SOT-23-THIN	DDF	8	3000	180.0	8.4	3.15	3.1	1.55	4.0	8.0	Q3
INA241A4QDGKRQ1	VSSOP	DGK	8	2500	330.0	12.4	5.3	3.4	1.4	8.0	12.0	Q1
INA241A4QDRQ1	SOIC	D	8	2500	330.0	12.4	6.4	5.2	2.1	8.0	12.0	Q1
INA241A5QDDFRQ1	SOT-23-THIN	DDF	8	3000	180.0	8.4	3.15	3.1	1.55	4.0	8.0	Q3
INA241A5QDDFRQ1	SOT-23-THIN	DDF	8	3000	180.0	8.4	3.2	3.2	1.4	4.0	8.0	Q3
INA241A5QDGKRQ1	VSSOP	DGK	8	2500	330.0	12.4	5.3	3.4	1.4	8.0	12.0	Q1
INA241A5QDRQ1	SOIC	D	8	2500	330.0	12.4	6.4	5.2	2.1	8.0	12.0	Q1
INA241B1QDDFRQ1	SOT-23-THIN	DDF	8	3000	180.0	8.4	3.2	3.2	1.4	4.0	8.0	Q3
INA241B1QDGKRQ1	VSSOP	DGK	8	2500	330.0	12.4	5.3	3.4	1.4	8.0	12.0	Q1
INA241B1QDRQ1	SOIC	D	8	2500	330.0	12.4	6.4	5.2	2.1	8.0	12.0	Q1
INA241B2QDDFRQ1	SOT-23-THIN	DDF	8	3000	180.0	8.4	3.2	3.2	1.4	4.0	8.0	Q3
INA241B2QDGKRQ1	VSSOP	DGK	8	2500	330.0	12.4	5.3	3.4	1.4	8.0	12.0	Q1
INA241B2QDRQ1	SOIC	D	8	2500	330.0	12.4	6.4	5.2	2.1	8.0	12.0	Q1
INA241B3QDDFRQ1	SOT-23-THIN	DDF	8	3000	180.0	8.4	3.2	3.2	1.4	4.0	8.0	Q3
INA241B3QDDFRQ1	SOT-23-THIN	DDF	8	3000	180.0	8.4	3.15	3.1	1.55	4.0	8.0	Q3
INA241B3QDGKRQ1	VSSOP	DGK	8	2500	330.0	12.4	5.3	3.4	1.4	8.0	12.0	Q1
INA241B3QDRQ1	SOIC	D	8	2500	330.0	12.4	6.4	5.2	2.1	8.0	12.0	Q1
INA241B4QDDFRQ1	SOT-23-THIN	DDF	8	3000	180.0	8.4	3.15	3.1	1.55	4.0	8.0	Q3
INA241B4QDDFRQ1	SOT-23-THIN	DDF	8	3000	180.0	8.4	3.2	3.2	1.4	4.0	8.0	Q3
INA241B4QDGKRQ1	VSSOP	DGK	8	2500	330.0	12.4	5.3	3.4	1.4	8.0	12.0	Q1
INA241B4QDRQ1	SOIC	D	8	2500	330.0	12.4	6.4	5.2	2.1	8.0	12.0	Q1
INA241B5QDDFRQ1	SOT-23-THIN	DDF	8	3000	180.0	8.4	3.2	3.2	1.4	4.0	8.0	Q3
INA241B5QDGKRQ1	VSSOP	DGK	8	2500	330.0	12.4	5.3	3.4	1.4	8.0	12.0	Q1
INA241B5QDRQ1	SOIC	D	8	2500	330.0	12.4	6.4	5.2	2.1	8.0	12.0	Q1

TAPE AND REEL BOX DIMENSIONS

*All dimensions are nominal

Device	Package Type	Package Drawing	Pins	SPQ	Length (mm)	Width (mm)	Height (mm)
INA241A1QDDFRQ1	SOT-23-THIN	DDF	8	3000	210.0	185.0	35.0
INA241A1QDGKRQ1	VSSOP	DGK	8	2500	356.0	356.0	35.0
INA241A1QDRQ1	SOIC	D	8	2500	353.0	353.0	32.0
INA241A2QDDFRQ1	SOT-23-THIN	DDF	8	3000	210.0	185.0	35.0
INA241A2QDDFRQ1	SOT-23-THIN	DDF	8	3000	210.0	185.0	35.0
INA241A2QDGKRQ1	VSSOP	DGK	8	2500	356.0	356.0	35.0
INA241A2QDRQ1	SOIC	D	8	2500	340.5	336.1	25.0
INA241A3QDDFRQ1	SOT-23-THIN	DDF	8	3000	210.0	185.0	35.0
INA241A3QDDFRQ1	SOT-23-THIN	DDF	8	3000	210.0	185.0	35.0
INA241A3QDGKRQ1	VSSOP	DGK	8	2500	356.0	356.0	35.0
INA241A3QDRQ1	SOIC	D	8	2500	340.5	336.1	25.0
INA241A4QDDFRQ1	SOT-23-THIN	DDF	8	3000	210.0	185.0	35.0
INA241A4QDDFRQ1	SOT-23-THIN	DDF	8	3000	210.0	185.0	35.0
INA241A4QDGKRQ1	VSSOP	DGK	8	2500	356.0	356.0	35.0
INA241A4QDRQ1	SOIC	D	8	2500	340.5	336.1	25.0
INA241A5QDDFRQ1	SOT-23-THIN	DDF	8	3000	210.0	185.0	35.0
INA241A5QDDFRQ1	SOT-23-THIN	DDF	8	3000	210.0	185.0	35.0
INA241A5QDGKRQ1	VSSOP	DGK	8	2500	356.0	356.0	35.0

Device	Package Type	Package Drawing	Pins	SPQ	Length (mm)	Width (mm)	Height (mm)
INA241A5QDRQ1	SOIC	D	8	2500	340.5	336.1	25.0
INA241B1QDDFRQ1	SOT-23-THIN	DDF	8	3000	210.0	185.0	35.0
INA241B1QDGKRQ1	VSSOP	DGK	8	2500	356.0	356.0	35.0
INA241B1QDRQ1	SOIC	D	8	2500	353.0	353.0	32.0
INA241B2QDDFRQ1	SOT-23-THIN	DDF	8	3000	210.0	185.0	35.0
INA241B2QDGKRQ1	VSSOP	DGK	8	2500	356.0	356.0	35.0
INA241B2QDRQ1	SOIC	D	8	2500	340.5	336.1	25.0
INA241B3QDDFRQ1	SOT-23-THIN	DDF	8	3000	210.0	185.0	35.0
INA241B3QDDFRQ1	SOT-23-THIN	DDF	8	3000	210.0	185.0	35.0
INA241B3QDGKRQ1	VSSOP	DGK	8	2500	356.0	356.0	35.0
INA241B3QDRQ1	SOIC	D	8	2500	340.5	336.1	25.0
INA241B4QDDFRQ1	SOT-23-THIN	DDF	8	3000	210.0	185.0	35.0
INA241B4QDDFRQ1	SOT-23-THIN	DDF	8	3000	210.0	185.0	35.0
INA241B4QDGKRQ1	VSSOP	DGK	8	2500	356.0	356.0	35.0
INA241B4QDRQ1	SOIC	D	8	2500	340.5	336.1	25.0
INA241B5QDDFRQ1	SOT-23-THIN	DDF	8	3000	210.0	185.0	35.0
INA241B5QDGKRQ1	VSSOP	DGK	8	2500	356.0	356.0	35.0
INA241B5QDRQ1	SOIC	D	8	2500	340.5	336.1	25.0

DDF0008A



PACKAGE OUTLINE

SOT-23-THIN - 1.1 mm max height

PLASTIC SMALL OUTLINE



4222047/E 07/2024

NOTES:

1. All linear dimensions are in millimeters. Any dimensions in parenthesis are for reference only. Dimensioning and tolerancing per ASME Y14.5M.
2. This drawing is subject to change without notice.
3. This dimension does not include mold flash, protrusions, or gate burrs. Mold flash, protrusions, or gate burrs shall not exceed 0.15 mm per side.

EXAMPLE BOARD LAYOUT

DDF0008A

SOT-23-THIN - 1.1 mm max height

PLASTIC SMALL OUTLINE



LAND PATTERN EXAMPLE
EXPOSED METAL SHOWN
SCALE:15X



SOLDER MASK DETAILS

4222047/E 07/2024

NOTES: (continued)

- 4. Publication IPC-7351 may have alternate designs.
- 5. Solder mask tolerances between and around signal pads can vary based on board fabrication site.

EXAMPLE STENCIL DESIGN

DDF0008A

SOT-23-THIN - 1.1 mm max height

PLASTIC SMALL OUTLINE



SOLDER PASTE EXAMPLE
BASED ON 0.125 mm THICK STENCIL
SCALE:15X

4222047/E 07/2024

NOTES: (continued)

6. Laser cutting apertures with trapezoidal walls and rounded corners may offer better paste release. IPC-7525 may have alternate design recommendations.
7. Board assembly site may have different recommendations for stencil design.



D0008A

PACKAGE OUTLINE

SOIC - 1.75 mm max height

SMALL OUTLINE INTEGRATED CIRCUIT



4214825/C 02/2019

NOTES:

- Linear dimensions are in inches [millimeters]. Dimensions in parenthesis are for reference only. Controlling dimensions are in inches. Dimensioning and tolerancing per ASME Y14.5M.
- This drawing is subject to change without notice.
- This dimension does not include mold flash, protrusions, or gate burrs. Mold flash, protrusions, or gate burrs shall not exceed $.006$ [0.15] per side.
- This dimension does not include interlead flash.
- Reference JEDEC registration MS-012, variation AA.

EXAMPLE BOARD LAYOUT

D0008A

SOIC - 1.75 mm max height

SMALL OUTLINE INTEGRATED CIRCUIT



LAND PATTERN EXAMPLE
 EXPOSED METAL SHOWN
 SCALE:8X



SOLDER MASK DETAILS

4214825/C 02/2019

NOTES: (continued)

- 6. Publication IPC-7351 may have alternate designs.
- 7. Solder mask tolerances between and around signal pads can vary based on board fabrication site.

EXAMPLE STENCIL DESIGN

D0008A

SOIC - 1.75 mm max height

SMALL OUTLINE INTEGRATED CIRCUIT



SOLDER PASTE EXAMPLE
BASED ON .005 INCH [0.125 MM] THICK STENCIL
SCALE:8X

4214825/C 02/2019

NOTES: (continued)

8. Laser cutting apertures with trapezoidal walls and rounded corners may offer better paste release. IPC-7525 may have alternate design recommendations.
9. Board assembly site may have different recommendations for stencil design.

DGK0008A



PACKAGE OUTLINE

VSSOP - 1.1 mm max height

SMALL OUTLINE PACKAGE

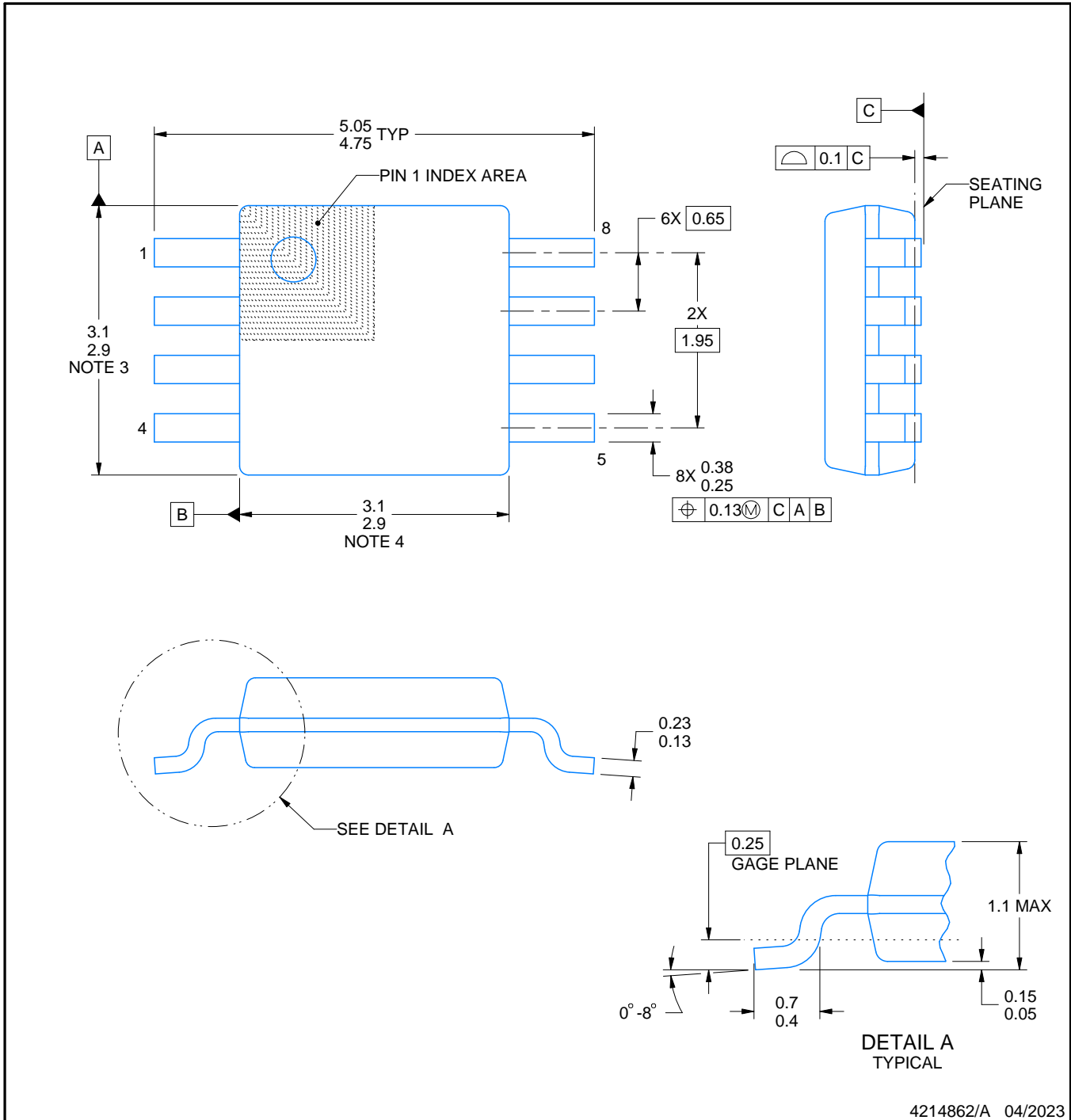

4214862/A 04/2023

NOTES:

PowerPAD is a trademark of Texas Instruments.

1. All linear dimensions are in millimeters. Any dimensions in parenthesis are for reference only. Dimensioning and tolerancing per ASME Y14.5M.
2. This drawing is subject to change without notice.
3. This dimension does not include mold flash, protrusions, or gate burrs. Mold flash, protrusions, or gate burrs shall not exceed 0.15 mm per side.
4. This dimension does not include interlead flash. Interlead flash shall not exceed 0.25 mm per side.
5. Reference JEDEC registration MO-187.

EXAMPLE BOARD LAYOUT

DGK0008A

™ VSSOP - 1.1 mm max height

SMALL OUTLINE PACKAGE



LAND PATTERN EXAMPLE
EXPOSED METAL SHOWN
SCALE: 15X



SOLDER MASK DETAILS

4214862/A 04/2023

NOTES: (continued)

6. Publication IPC-7351 may have alternate designs.
7. Solder mask tolerances between and around signal pads can vary based on board fabrication site.
8. Vias are optional depending on application, refer to device data sheet. If any vias are implemented, refer to their locations shown on this view. It is recommended that vias under paste be filled, plugged or tented.
9. Size of metal pad may vary due to creepage requirement.

EXAMPLE STENCIL DESIGN

DGK0008A

TM VSSOP - 1.1 mm max height

SMALL OUTLINE PACKAGE



SOLDER PASTE EXAMPLE
SCALE: 15X

4214862/A 04/2023

NOTES: (continued)

11. Laser cutting apertures with trapezoidal walls and rounded corners may offer better paste release. IPC-7525 may have alternate design recommendations.
12. Board assembly site may have different recommendations for stencil design.

IMPORTANT NOTICE AND DISCLAIMER

TI PROVIDES TECHNICAL AND RELIABILITY DATA (INCLUDING DATA SHEETS), DESIGN RESOURCES (INCLUDING REFERENCE DESIGNS), APPLICATION OR OTHER DESIGN ADVICE, WEB TOOLS, SAFETY INFORMATION, AND OTHER RESOURCES "AS IS" AND WITH ALL FAULTS, AND DISCLAIMS ALL WARRANTIES, EXPRESS AND IMPLIED, INCLUDING WITHOUT LIMITATION ANY IMPLIED WARRANTIES OF MERCHANTABILITY, FITNESS FOR A PARTICULAR PURPOSE OR NON-INFRINGEMENT OF THIRD PARTY INTELLECTUAL PROPERTY RIGHTS.

These resources are intended for skilled developers designing with TI products. You are solely responsible for (1) selecting the appropriate TI products for your application, (2) designing, validating and testing your application, and (3) ensuring your application meets applicable standards, and any other safety, security, regulatory or other requirements.

These resources are subject to change without notice. TI grants you permission to use these resources only for development of an application that uses the TI products described in the resource. Other reproduction and display of these resources is prohibited. No license is granted to any other TI intellectual property right or to any third party intellectual property right. TI disclaims responsibility for, and you will fully indemnify TI and its representatives against, any claims, damages, costs, losses, and liabilities arising out of your use of these resources.

TI's products are provided subject to [TI's Terms of Sale](#) or other applicable terms available either on [ti.com](https://www.ti.com) or provided in conjunction with such TI products. TI's provision of these resources does not expand or otherwise alter TI's applicable warranties or warranty disclaimers for TI products.

TI objects to and rejects any additional or different terms you may have proposed.

Mailing Address: Texas Instruments, Post Office Box 655303, Dallas, Texas 75265
Copyright © 2024, Texas Instruments Incorporated