

# LM99 $\pm 1^\circ\text{C}$ Accurate, High Temperature, Remote Diode Temperature Sensor with Two-Wire Interface

Check for Samples: [LM99](#)

## FEATURES

- Accurately Senses the Temperature of Remote Diodes
- Offset Register Allows Use of a Variety of Thermal Diodes
- On-board Local Temperature Sensing
- 10 Bit Plus Sign Remote Diode Temperature Data Format,  $0.125^\circ\text{C}$  Resolution
- $\overline{\text{T\_CRIT\_A}}$  Output Useful for System Shutdown
- $\overline{\text{ALERT}}$  Output Supports SMBus 2.0 Protocol
- SMBus 2.0 Compatible Interface, Supports TIMEOUT
- 8-Pin VSSOP Package

## APPLICATIONS

- Graphics Processor Thermal Management
- Computer Processor Thermal Management
- Electronic Test Equipment
- Office Electronics

## KEY SPECIFICATIONS

- Supply Voltage 3.0 V to 3.6 V
- Supply Current 0.8 mA (typ)
- Local Temp Accuracy (Includes Quantization error)
  - $T_A = 25^\circ\text{C}$  to  $125^\circ\text{C} \pm 3.0^\circ\text{C}$  (Max)
- Remote Diode Temp Accuracy (Includes Quantization Error)
  - $T_A = 30^\circ\text{C}$  to  $50^\circ\text{C}$ ,  $T_D = 120^\circ\text{C}$  to  $140^\circ\text{C} \pm 1.0^\circ\text{C}$  (Max)
  - $T_A = 0^\circ\text{C}$  to  $85^\circ\text{C}$ ,  $T_D = 25^\circ\text{C}$  to  $140^\circ\text{C} \pm 3.0^\circ\text{C}$  (Max)

## DESCRIPTION

The LM99 is an 11-bit remote diode temperature sensor with a 2-wire System Management Bus (SMBus) serial interface. The LM99 accurately measures: (1) its own temperature and (2) the temperature of a remote diode-connected transistor such as the 2N3904 or a thermal diode commonly found on Graphics Processor Units (GPU), Computer Processor Units (CPU or other ASICs). The LM99 remote diode temperature sensor shifts the temperature from the remote sensor down  $16^\circ\text{C}$  and operates on that shifted temperature:

$$T_{\text{ACTUAL DIODE JUNCTION}} = T_{\text{LM99}} + 16^\circ\text{C}$$

The local temperature reading requires no offset.

The LM99 has an Offset Register which provides a means for precise matching to various thermal diodes.

The LM99 and LM99-1 have the same functions but different SMBus slave addresses. This allows for one of each to be on the same bus at the same time.

Activation of the  $\overline{\text{ALERT}}$  output occurs when any temperature goes outside a preprogrammed window set by the HIGH and LOW temperature limit registers or exceeds the  $\overline{\text{T\_CRIT}}$  temperature limit. Activation of the  $\overline{\text{T\_CRIT\_A}}$  occurs when any temperature exceeds the  $\overline{\text{T\_CRIT}}$  programmed limit.



Please be aware that an important notice concerning availability, standard warranty, and use in critical applications of Texas Instruments semiconductor products and disclaimers thereto appears at the end of this data sheet.

All trademarks are the property of their respective owners.

### Simplified Block Diagram

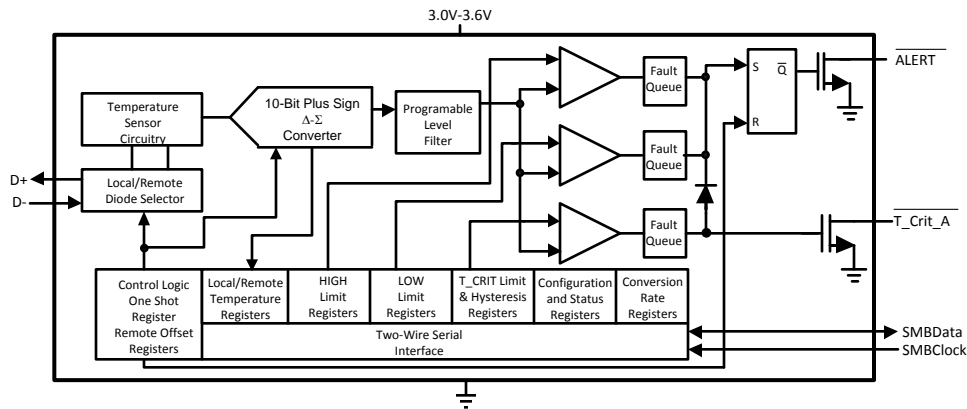

### Connection Diagram

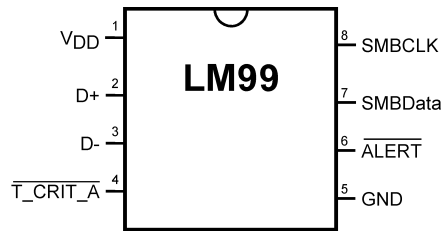
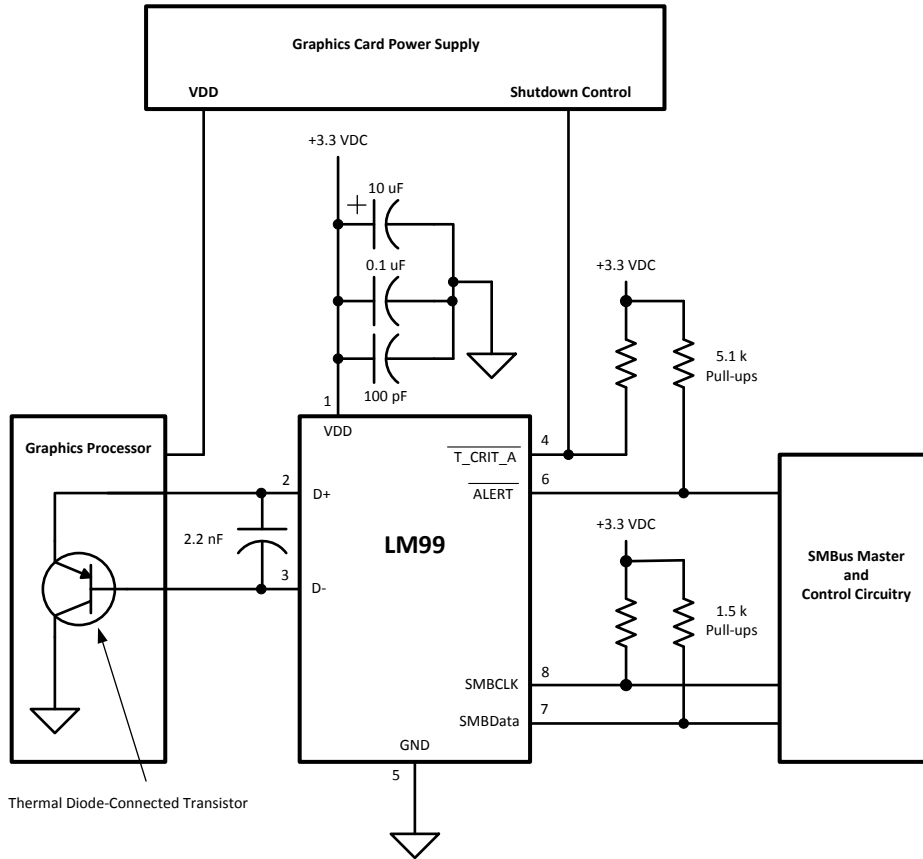

Figure 1. VSSOP-8 TOP VIEW

### PIN DESCRIPTIONS

| Label               | Pin # | Function   | Typical Connection  |
|---------------------|-------|--|---|
| V <sub>DD</sub>     | 1     | Positive Supply Voltage Input                          | DC Voltage from 3.0 V to 3.6 V. V <sub>DD</sub> should be bypassed with a 0.1 μF capacitor in parallel with 100 pF to ground. The 100 pF capacitor should be placed as close as possible to the power supply pin. A bulk capacitance of approximately 10 μF needs to be in the vicinity of the LM99 V <sub>DD</sub> . |
| D+                  | 2     | Diode Current Source                                   | To Diode Anode. Connected to the collector and base of the remote discrete diode-connected transistor. Connect a 2.2 nF capacitor between pins 2 and 3.   |
| D-                  | 3     | Diode Return Current Sink                              | To Diode Cathode. Connects to the emitter of the remote diode-connected transistor. Connect a 2.2 nF capacitor between pins 2 and 3.  |
| T <sub>CRIT_A</sub> | 4     | T <sub>CRIT</sub> Alarm Output, Open-Drain, Active-Low | Pull-Up Resistor, Controller Interrupt or Power Supply Shutdown Control   |
| GND                 | 5     | Power Supply Ground                                    | Ground  |
| ALERT               | 6     | Interrupt Output, Open-Drain, Active-Low               | Pull-Up Resistor, Controller Interrupt or Alert Line  |
| SMBData             | 7     | SMBus Bi-Directional Data Line, Open-Drain Output      | From and to Controller, Pull-Up Resistor  |
| SMBCLK              | 8     | SMBus Input  | From Controller, Pull-Up Resistor   |

## Typical Application



These devices have limited built-in ESD protection. The leads should be shorted together or the device placed in conductive foam during storage or handling to prevent electrostatic damage to the MOS gates.

## Absolute Maximum Ratings<sup>(1)</sup>

|  |                                 |                                     |
|--|---------------------------------|-------------------------------------|
| Supply Voltage                                 |                                 | -0.3 V to 6.0 V                     |
| Voltage at SMBData, SMBCLK, ALERT, T_CRIT_A    |                                 | -0.5 V to 6.0 V                     |
| Voltage at Other Pins                          |                                 | -0.3 V to (V <sub>DD</sub> + 0.3 V) |
| D- Input Current                               |                                 | ±1 mA                               |
| Input Current at All Other Pins <sup>(2)</sup> |                                 | ±5 mA                               |
| Package Input Current <sup>(2)</sup>           |                                 | 30 mA                               |
| SMBData, ALERT, T_CRIT_A Output Sink Current   |                                 | 10 mA                               |
| Storage Temperature                            |                                 | -65°C to +150°C                     |
| Soldering Information, Lead Temperature        | VSSOP-8 Packages <sup>(3)</sup> | Vapor Phase (60 seconds)<br>215°C   |
|  |                                 | Infrared (15 seconds)<br>220°C      |
| ESD Susceptibility <sup>(4)</sup>              | Human Body Model                | 2000 V                              |
|  | Machine Model                   | 200 V                               |

- (1) Absolute Maximum Ratings indicate limits beyond which damage to the device may occur. DC and AC electrical specifications do not apply when operating the device beyond its rated operating conditions.
- (2) When the input voltage (V<sub>I</sub>) at any pin exceeds the power supplies (V<sub>I</sub> < GND or V<sub>I</sub> > V<sub>DD</sub>), the current at that pin should be limited to 5 mA. Parasitic components and or ESD protection circuitry are shown in the figure below for the LM99's pins. The nominal breakdown voltage of D3 is 6.5 V. Care should be taken not to forward bias the parasitic diode, D1, present on pins: D+, D-. Doing so by more than 50 mV may corrupt a temperature measurement.
- (3) See <http://www.ti.com/packaging> for other recommendations and methods of soldering surface mount devices.
- (4) Human body model, 100 pF discharged through a 1.5 kΩ resistor. Machine model, 200 pF discharged directly into each pin.

## Operating Ratings

|   |  |
|---|--|
| Operating Temperature Range                                 | 0°C to +125°C  |
| Electrical Characteristics Temperature Range <sup>(1)</sup> | T <sub>MIN</sub> ≤ T <sub>A</sub> ≤ T <sub>MAX</sub> |
| LM99  | 0°C ≤ T <sub>A</sub> ≤ +85°C                         |
| Supply Voltage Range (V <sub>DD</sub> )                     | +3.0 V to +3.6 V                                     |

- (1) Thermal resistance junction-to-ambient when attached to a printed circuit board with 2 oz. foil:  
— VSSOP-8 = 210°C/W

## Temperature-to-Digital Converter Characteristics

Unless otherwise noted, these specifications apply for V<sub>DD</sub> = +3.0 Vdc to +3.6 Vdc. **Boldface limits apply for T<sub>A</sub> = T<sub>J</sub> = T<sub>MIN</sub> ≤ T<sub>A</sub> ≤ T<sub>MAX</sub>**; all other limits T<sub>A</sub> = T<sub>J</sub> = +25°C, unless otherwise noted.

| Parameter  | Conditions  | Typical <sup>(1)</sup> | Limits <sup>(2)</sup> | Units (Limit) |
|--|---|------------------------|-----------------------|---------------|
| Temperature Error Using Local Diode  | T <sub>A</sub> = +25°C to +125°C <sup>(3)</sup>                       | ±1                     | <b>±3</b>             | °C (max)      |
| Temperature Error Using Remote Diode Connected Transistor (T <sub>D</sub> is the Remote Diode Junction Temperature)<br>T <sub>D</sub> = T <sub>LM99</sub> + 16°C | T <sub>A</sub> = +30°C to +50°C and T <sub>D</sub> = +120°C to +140°C |                        | <b>±1</b>             | °C (max)      |
|  | T <sub>A</sub> = +0°C to +85°C and T <sub>D</sub> = +25°C to +140°C   |                        | <b>±3</b>             | °C (max)      |
| Remote Diode Measurement Resolution  |   | 11                     |                       | Bits          |
|  |   | 0.125                  |                       | °C            |
| Local Diode Measurement Resolution   |   | 8                      |                       | Bits          |
|  |   | 1                      |                       | °C            |
| Conversion Time of All Temperatures at the Fastest Setting   | See <sup>(4)</sup>  | 31.25                  | <b>34.4</b>           | ms (max)      |

- (1) Typicals are at T<sub>A</sub> = 25°C and represent most likely parametric normal.
- (2) Limits are ensured to AOQL (Average Outgoing Quality Level).
- (3) Local temperature accuracy does not include the effects of self-heating. The rise in temperature due to self-heating is the product of the internal power dissipation of the LM99 and the thermal resistance. See [Note 1](#) of the Operating Ratings table for the thermal resistance to be used in the self-heating calculation.
- (4) This specification is provided only to indicate how often temperature data is updated. The LM99 can be read at any time without regard to conversion state (and will yield last conversion result).

## Temperature-to-Digital Converter Characteristics (continued)

Unless otherwise noted, these specifications apply for  $V_{DD} = +3.0$  Vdc to  $+3.6$  Vdc. **Boldface limits apply for  $T_A = T_J = T_{MIN} \leq T_A \leq T_{MAX}$** ; all other limits  $T_A = T_J = +25^\circ\text{C}$ , unless otherwise noted.

| Parameter  | Conditions   | Typical <sup>(1)</sup> | Limits <sup>(2)</sup>    | Units (Limit)       |
|--|--|------------------------|--------------------------|---------------------|
| Quiescent Current <sup>(5)</sup>   | SMBus Inactive, 16 Hz conversion rate  | 0.8                    | <b>1.7</b>               | mA (max)            |
|  | Shutdown   | 315                    |                          | $\mu\text{A}$       |
| D- Source Voltage  |  | 0.7                    |                          | V                   |
| Diode Source Current   | $(V_{D+} - V_{D-}) = +0.65$ V; high level  | 160                    | <b>315</b>               | $\mu\text{A}$ (max) |
|  |  |                        | <b>110</b>               | $\mu\text{A}$ (min) |
|  | Low level  | 13                     | <b>20</b>                | $\mu\text{A}$ (max) |
|  |  |                        | <b>7</b>                 | $\mu\text{A}$ (min) |
| $\overline{\text{ALERT}}$ and $\overline{\text{T\_CRIT\_A}}$ Output Saturation Voltage | $I_{OUT} = 6.0$ mA   |                        | <b>0.4</b>               | V (max)             |
| Power-On-Reset (POR) Threshold   | Measure on $V_{DD}$ input, falling edge  |                        | <b>2.4</b><br><b>1.8</b> | V (max)<br>V (min)  |
| Local and Remote HIGH Default Temperature settings                                     | See <sup>(6)</sup> Add $16^\circ\text{C}$ for true Remote Temperature.                       | +70                    |                          | $^\circ\text{C}$    |
| Local and Remote LOW Default Temperature settings                                      | See <sup>(6)</sup> Add $16^\circ\text{C}$ for true Remote Temperature.                       | 0                      |                          | $^\circ\text{C}$    |
| Local T_CRIT Default Temperature Setting   | See <sup>(6)</sup>   | +85                    |                          | $^\circ\text{C}$    |
| Remote T_CRIT Default Temperature Setting  | See <sup>(6)</sup> Add $16^\circ\text{C}$ for $126^\circ\text{C}$ true Remote T_CRIT Setting | +110                   |                          | $^\circ\text{C}$    |

(5) Quiescent current will not increase substantially with an SMBus.

(6) Default values set at power up.

## Logic Electrical Characteristics

### DIGITAL DC CHARACTERISTICS

Unless otherwise noted, these specifications apply for  $V_{DD} = +3.0$  to  $3.6$  Vdc. **Boldface limits apply for  $T_A = T_J = T_{MIN}$  to  $T_{MAX}$** ; all other limits  $T_A = T_J = +25^\circ\text{C}$ , unless otherwise noted.

| Symbol                        | Parameter                                   | Conditions                         | Typical <sup>(1)</sup> | Limits <sup>(2)</sup>      | Units (Limit)       |
|-------------------------------|---|------------------------------------|------------------------|----------------------------|---------------------|
| <b>SMBData, SMBCLK INPUTS</b> |   |                                    |                        |                            |                     |
| $V_{IN(1)}$                   | Logical "1" Input Voltage                   |                                    |                        | <b>2.1</b>                 | V (min)             |
| $V_{IN(0)}$                   | Logical "0" Input Voltage                   |                                    |                        | <b>0.8</b>                 | V (max)             |
| $V_{IN(HYST)}$                | SMBData and SMBCLK Digital Input Hysteresis |                                    | 400                    |                            | mV                  |
| $I_{IN(1)}$                   | Logical "1" Input Current                   | $V_{IN} = V_{DD}$                  | 0.005                  | <b><math>\pm 10</math></b> | $\mu\text{A}$ (max) |
| $I_{IN(0)}$                   | Logical "0" Input Current                   | $V_{IN} = 0$ V                     | -0.005                 | <b><math>\pm 10</math></b> | $\mu\text{A}$ (max) |
| $C_{IN}$                      | Input Capacitance                           |                                    | 5                      |                            | pF                  |
| <b>ALL DIGITAL OUTPUTS</b>    |   |                                    |                        |                            |                     |
| $I_{OH}$                      | High Level Output Current                   | $V_{OH} = V_{DD}$                  |                        | <b>10</b>                  | $\mu\text{A}$ (max) |
| $V_{OL}$                      | SMBus Low Level Output Voltage              | $I_{OL} = 4$ mA<br>$I_{OL} = 6$ mA |                        | <b>0.4</b><br><b>0.6</b>   | V (max)             |

(1) Typicals are at  $T_A = 25^\circ\text{C}$  and represent most likely parametric normal.

(2) Limits are ensured to AOQL (Average Outgoing Quality Level).

## SMBus Digital Switching Characteristics

Unless otherwise noted, these specifications apply for  $V_{DD} = +3.0$  Vdc to  $+3.6$  Vdc,  $C_L$  (load capacitance) on output lines = 80 pF. **Boldface limits apply for  $T_A = T_J = T_{MIN}$  to  $T_{MAX}$** ; all other limits  $T_A = T_J = +25^\circ\text{C}$ , unless otherwise noted.

The switching characteristics of the LM99 fully meet or exceed the published specifications of the SMBus version 2.0. The following parameters are the timing relationships between SMBCLK and SMBData signals related to the LM99. They adhere to but are not necessarily the SMBus bus specifications.

| Symbol        | Parameter  | Conditions                                     | Typical <sup>(1)</sup> | Limits <sup>(2)</sup>    | Units (Limit)                   |
|---------------|--|--|------------------------|--------------------------|---------------------------------|
| $f_{SMB}$     | SMBus Clock Frequency  |  |                        | <b>100</b><br><b>10</b>  | kHz (max)<br>kHz (min)          |
| $t_{LOW}$     | SMBus Clock Low Time   | from $V_{IN(0)max}$ to $V_{IN(0)max}$          |                        | <b>4.7</b><br><b>25</b>  | $\mu\text{s}$ (min)<br>ms (max) |
| $t_{HIGH}$    | SMBus Clock High Time  | from $V_{IN(1)min}$ to $V_{IN(1)min}$          |                        | <b>4.0</b>               | $\mu\text{s}$ (min)             |
| $t_{R,SMB}$   | SMBus Rise Time  | See <sup>(3)</sup>                             | 1                      |                          | $\mu\text{s}$ (max)             |
| $t_{F,SMB}$   | SMBus Fall Time  | See <sup>(4)</sup>                             | 0.3                    |                          | $\mu\text{s}$ (max)             |
| $t_{OF}$      | Output Fall Time   | $C_L = 400$ pF,<br>$I_O = 3$ mA <sup>(4)</sup> |                        | <b>250</b>               | ns (max)                        |
| $t_{TIMEOUT}$ | SMBData and SMBCLK Time Low for Reset of Serial Interface <sup>(5)</sup>                             |  |                        | <b>25</b><br><b>35</b>   | ms (min)<br>ms (max)            |
| $t_{SU,DAT}$  | Data In Setup Time to SMBCLK High  |  |                        | <b>250</b>               | ns (min)                        |
| $t_{HD,DAT}$  | Data Out Stable after SMBCLK Low   |  |                        | <b>300</b><br><b>900</b> | ns (min)<br>ns (max)            |
| $t_{HD,STA}$  | Start Condition SMBData Low to SMBCLK Low (Start condition hold before the first clock falling edge) |  |                        | <b>100</b>               | ns (min)                        |
| $t_{SU,STO}$  | Stop Condition SMBCLK High to SMBData Low (Stop Condition Setup)                                     |  |                        | <b>100</b>               | ns (min)                        |
| $t_{SU,STA}$  | SMBus Repeated Start-Condition Setup Time, SMBCLK High to SMBData Low                                |  |                        | <b>0.6</b>               | $\mu\text{s}$ (min)             |
| $t_{BUF}$     | SMBus Free Time Between Stop and Start Conditions  |  |                        | <b>1.3</b>               | $\mu\text{s}$ (min)             |

(1) Typicals are at  $T_A = 25^\circ\text{C}$  and represent most likely parametric normal.

(2) Limits are ensured to AOQL (Average Outgoing Quality Level).

(3) The output rise time is measured from  $(V_{IN(0)max} + 0.15$  V) to  $(V_{IN(1)min} - 0.15$  V).

(4) The output fall time is measured from  $(V_{IN(1)min} - 0.15$  V) to  $(V_{IN(1)min} + 0.15$  V).

(5) Holding the SMBData and/or SMBCLK lines Low for a time interval greater than  $t_{TIMEOUT}$  will reset the LM99's SMBus state machine, therefore setting SMBData and SMBCLK pins to a high impedance state.

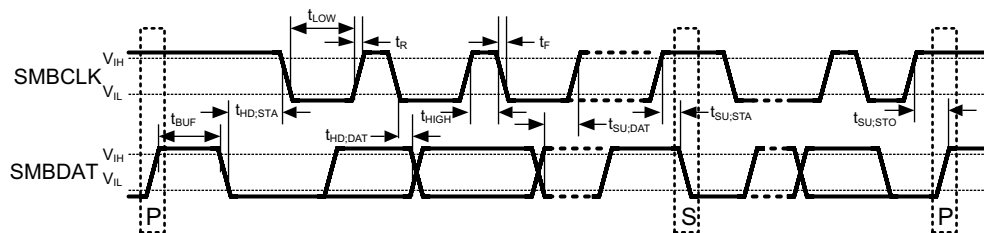

Figure 2. SMBus Communication

| Pin Name                | PIN # | D1               | D2 | D3 | D4 | D5 | D6 | D7 | R1 | SNP | ESD CLAMP |
|-------------------------|-------|------------------|----|----|----|----|----|----|----|-----|-----------|
| V <sub>DD</sub>         | 1     |                  |    |    |    |    |    |    |    |     | X         |
| D+                      | 2     | x <sup>(1)</sup> | x  |    |    |    | X  | X  | X  |     | X         |
| D-                      | 3     | x                | x  |    |    | X  | X  | X  |    |     | X         |
| $\overline{T\_CRIT\_A}$ | 4     |                  |    |    |    |    |    | X  | X  | X   |           |
| $\overline{ALERT}$      | 6     |                  |    |    |    |    |    | X  | X  | X   |           |
| SMBData                 | 7     |                  |    |    |    |    |    | X  | X  | X   |           |
| SMBCLK                  | 8     |                  |    |    |    |    |    |    |    | X   |           |

(1) Note: An “x” indicates that the diode exists.

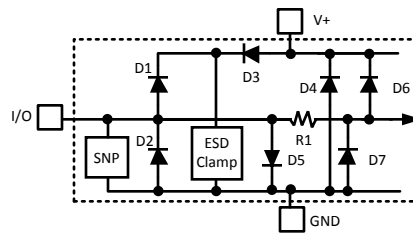

Figure 3. ESD Protection Input Structure

## FUNCTIONAL DESCRIPTION

The LM99 temperature sensor incorporates a delta  $V_{BE}$  based temperature sensor using a Local or Remote diode and a 10-bit plus sign  $\Delta\Sigma$  ADC (Delta-Sigma Analog-to-Digital Converter). The LM99 is compatible with the serial SMBus version 2.0 two-wire interface. Digital comparators compare the measured Local Temperature (LT) to the Local High (LHS), Local Low (LLS) and Local T\_CRIT (LCS) user-programmable temperature limit registers. The measured Remote Temperature (RT) is digitally compared to the Remote High (RHS), Remote Low (RLS) and Remote T\_CRIT (RCS) user-programmable temperature limit registers. Activation of the  $\overline{\text{ALERT}}$  output indicates that a comparison is greater than the limit preset in a T\_CRIT or HIGH limit register or less than the limit preset in a LOW limit register. The  $\overline{\text{T\_CRIT\_A}}$  output responds as a true comparator with built in hysteresis. The hysteresis is set by the value placed in the  $\overline{\text{Hysteresis}}$  register (TH). Activation of  $\overline{\text{T\_CRIT\_A}}$  occurs when the temperature is above the T\_CRIT setpoint.  $\overline{\text{T\_CRIT\_A}}$  remains activated until the temperature goes below the setpoint calculated by  $\overline{\text{T\_CRIT}} - \overline{\text{TH}}$ . The hysteresis register impacts both the remote temperature and local temperature readings.

The LM99 may be placed in a low power consumption (Shutdown) mode by setting the  $\overline{\text{RUN/STOP}}$  bit found in the Configuration register. In the Shutdown mode, the LM99's SMBus interface remains while all circuitry not required is turned off.

The Local temperature reading and setpoint data registers are 8-bits wide. The format of the 11-bit remote temperature data is a 16-bit left justified word. Two 8-bit registers, high and low bytes, are provided for each setpoint as well as the temperature reading. Two offset registers (RTOLB and RTOHB) can be used to compensate for non-ideality error, discussed further in [DIODE NON-IDEALITY](#). The remote temperature reading reported is adjusted by subtracting from, or adding to, the actual temperature reading the value placed in the offset register.

## CONVERSION SEQUENCE

The LM99 takes approximately 31.25 ms to convert the Local Temperature (LT), Remote Temperature (RT), and to update all of its registers. Only during the conversion process the busy bit (D7) in the Status register (02h) is high. These conversions are addressed in a round-robin sequence. The conversion rate may be modified by the Conversion Rate Register (04h). When the conversion rate is modified a delay is inserted between conversions; however, the actual conversion time remains at 31.25 ms. Different conversion rates will cause the LM99 to draw different amounts of supply current as shown in [Figure 4](#).

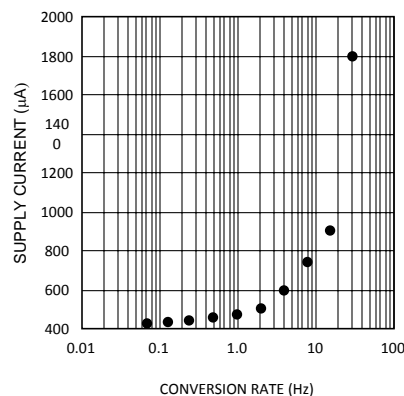

Figure 4. Conversion Rate Effect on Power Supply Current

## THE $\overline{\text{ALERT}}$ OUTPUT

The LM99's  $\overline{\text{ALERT}}$  pin is an active-low open-drain output that is triggered by a temperature conversion that is outside the limits defined by the temperature setpoint registers. Reset of the  $\overline{\text{ALERT}}$  output is dependent upon the selected method of use. The LM99's  $\overline{\text{ALERT}}$  pin is versatile and will accommodate three different methods of use to best serve the system designer: as a temperature comparator, as a temperature-based interrupt flag, and as part of an SMBus ALERT system. The three methods of use are further described below. The ALERT and interrupt methods are different only in how the user interacts with the LM99.



Each temperature reading (LT and RT) is associated with a T\_CRIT setpoint register (LCS, RCS), a HIGH setpoint register (LHS and RHS) and a LOW setpoint register (LLS and RLS). At the end of every temperature reading, a digital comparison determines whether that reading is above its HIGH or T\_CRIT setpoint or below its LOW setpoint. If so, the corresponding bit in the STATUS REGISTER is set. If the ALERT mask bit is not high, any bit set in the STATUS REGISTER, with the exception of Busy (D7) and OPEN (D2), will cause the ALERT output to be pulled low. Any temperature conversion that is out of the limits defined by the temperature setpoint registers will trigger an ALERT. Additionally, the ALERT mask bit in the Configuration register must be cleared to trigger an ALERT in all modes.

### ALERT Output as a Temperature Comparator

When the LM99 is implemented in a system in which it is not serviced by an interrupt routine, the  $\overline{\text{ALERT}}$  output could be used as a temperature comparator. Under this method of use, once the condition that triggered the  $\overline{\text{ALERT}}$  to go low is no longer present, the  $\overline{\text{ALERT}}$  is de-asserted (Figure 5). For example, if the  $\overline{\text{ALERT}}$  output was activated by the comparison of  $\text{LT} > \text{LHS}$ , when this condition is no longer true the  $\overline{\text{ALERT}}$  will return HIGH. This mode allows operation without software intervention, once all registers are configured during set-up. In order for the  $\overline{\text{ALERT}}$  to be used as a temperature comparator, bit D0 (the ALERT configure bit) in the FILTER and ALERT CONFIGURE REGISTER (xBF) must be set high. This is not the power on default default state.

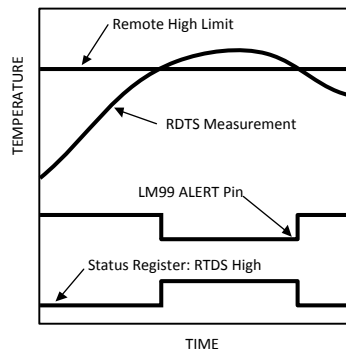

Figure 5.  $\overline{\text{ALERT}}$  Comparator Temperature Response Diagram

### ALERT Output as an Interrupt

The LM99's  $\overline{\text{ALERT}}$  output can be implemented as a simple interrupt signal when it is used to trigger an interrupt service routine. In such systems it is undesirable for the interrupt flag to repeatedly trigger during or before the interrupt service routine has been completed. Under this method of operation, during a read of the STATUS REGISTER the LM99 will set the ALERT mask bit (D7 of the Configuration register) if any bit in the STATUS REGISTER is set, with the exception of Busy (D7) and OPEN (D2). This prevents further  $\overline{\text{ALERT}}$  triggering until the master has reset the ALERT mask bit, at the end of the interrupt service routine. The STATUS REGISTER bits are cleared only upon a read command from the master (see Figure 6) and will be re-asserted at the end of the next conversion if the triggering condition(s) persist(s). In order for the  $\overline{\text{ALERT}}$  to be used as a dedicated interrupt signal, bit D0 (the ALERT configure bit) in the FILTER and ALERT CONFIGURE REGISTER (xBF) must be set low. This is the power-on default state.

The following sequence describes the response of a system that uses the  $\overline{\text{ALERT}}$  output pin as an interrupt flag:

1. Master Senses  $\overline{\text{ALERT}}$  low
2. Master reads the LM99 STATUS REGISTER to determine what caused the  $\overline{\text{ALERT}}$
3. LM99 clears STATUS REGISTER, resets the  $\overline{\text{ALERT}}$  HIGH and sets the ALERT mask bit (D7 in the Configuration register).
4. Master attends to conditions that caused the  $\overline{\text{ALERT}}$  to be triggered. The fan is started, setpoint limits are adjusted, etc.
5. Master resets the  $\overline{\text{ALERT}}$  mask (D7 in the Configuration register).

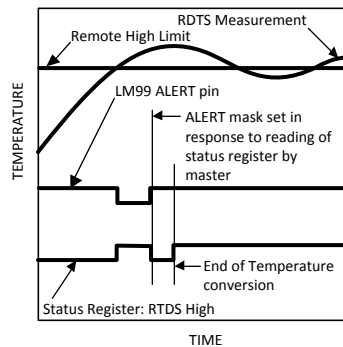

**Figure 6.  $\overline{\text{ALERT}}$  Output as an Interrupt Temperature Response Diagram**

### **$\overline{\text{ALERT}}$ Output as an SMBus ALERT**

When the  $\overline{\text{ALERT}}$  output is connected to one or more  $\overline{\text{ALERT}}$  outputs of other SMBus compatible devices and to a master, an SMBus alert line is created. Under this implementation, the LM99's ALERT should be operated using the ARA (Alert Response Address) protocol. The SMBus 2.0 ARA protocol, defined in the SMBus specification 2.0, is a procedure designed to assist the master in resolving which part generated an interrupt and service that interrupt while impeding system operation as little as possible.

The SMBus alert line is connected to the open-drain ports of all devices on the bus thereby AND'ing them together. The ARA is a method by which with one command the SMBus master may identify which part is pulling the SMBus alert line LOW and prevent it from pulling it LOW again for the same triggering condition. When an ARA command is received by all devices on the bus, the devices pulling the SMBus alert line LOW, first, send their address to the master and second, release the SMBus alert line after recognizing a successful transmission of their address.

The SMBus 1.1 and 2.0 specification state that in response to an ARA (Alert Response Address) "after acknowledging the slave address the device must disengage its  $\overline{\text{SMBALERT}}$  pulldown". Furthermore, "if the host still sees  $\overline{\text{SMBALERT}}$  low when the message transfer is complete, it knows to read the ARA again". This SMBus "disengaging of  $\overline{\text{SMBALERT}}$ " requirement prevents locking up the SMBus alert line. Competitive parts may address this "disengaging of  $\overline{\text{SMBALERT}}$ " requirement differently than the LM99 or not at all. SMBus systems that implement the ARA protocol as suggested for the LM99 will be fully compatible with all competitive parts.

The LM99 fulfills "disengaging of  $\overline{\text{SMBALERT}}$ " by setting the ALERT mask bit (bit D7 in the Configuration register, at address 09h) after successfully sending out its address in response to an ARA and releasing the ALERT output pin. Once the ALERT mask bit is activated, the  $\overline{\text{ALERT}}$  output pin will be disabled until enabled by software. In order to enable the  $\overline{\text{ALERT}}$  the master must read the STATUS REGISTER, at address 02h, during the interrupt service routine and then reset the ALERT mask bit in the Configuration register to 0 at the end of the interrupt service routine.

The following sequence describes the ARA response protocol.

1. Master Senses SMBus alert line low
2. Master sends a START followed by the Alert Response Address (ARA) with a Read Command.
3. Alerting Device(s) send ACK.
4. Alerting Device(s) send their Address. While transmitting their address, alerting devices sense whether their address has been transmitted correctly. (The LM99 will reset its  $\overline{\text{ALERT}}$  output and set the ALERT mask bit once its complete address has been transmitted successfully.)
5. Master/slave NoACK
6. Master sends STOP
7. Master attends to conditions that caused the  $\overline{\text{ALERT}}$  to be triggered. The STATUS REGISTER is read and fan started, setpoint limits adjusted, etc.
8. Master resets the ALERT mask (D7 in the Configuration register).

The ARA, 000 1100, is a general call address. No device should ever be assigned this address.

Bit D0 (the  $\overline{\text{ALERT}}$  configure bit) in the FILTER and ALERT CONFIGURE REGISTER (xBF) must be set low in order for the LM99 to respond to the ARA command.

The  $\overline{\text{ALERT}}$  output can be disabled by setting the ALERT mask bit, D7, of the Configuration register. The power on default is to have the ALERT mask bit and the  $\overline{\text{ALERT}}$  configure bit low.

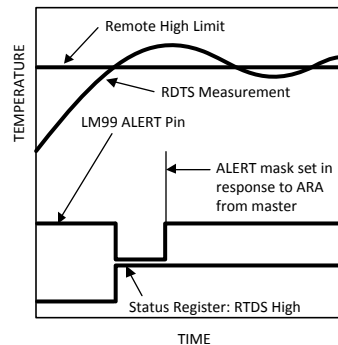
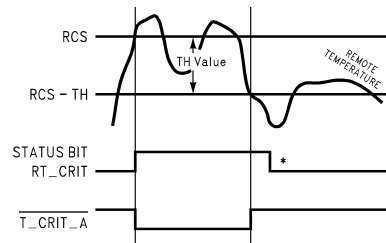

Figure 7.  $\overline{\text{ALERT}}$  Output as an SMBus ALERT Temperature Response Diagram

### $\overline{\text{T\_CRIT\_A}}$ OUTPUT and $\text{T\_CRIT}$ LIMIT

$\overline{\text{T\_CRIT\_A}}$  is activated when any temperature reading is greater than the limit preset in the critical temperature setpoint register ( $\text{T\_CRIT}$ ), as shown in Figure 8. The Status Register can be read to determine which event caused the alarm. A bit in the Status Register is set high to indicate which temperature reading exceeded the  $\text{T\_CRIT}$  setpoint temperature and caused the alarm, see STATUS REGISTER (SR).

Local and remote temperature diodes are sampled in sequence by the A/D converter. The  $\overline{\text{T\_CRIT\_A}}$  output and the Status Register flags are updated after every Local and Remote temperature conversion.  $\overline{\text{T\_CRIT\_A}}$  follows the state of the comparison, it is reset when the temperature falls below the setpoint RCS-TH. The Status Register flags are reset only after the Status Register is read and if a temperature conversion(s) is/are below the  $\text{T\_CRIT}$  setpoint, as shown in STATUS REGISTER (SR).



\* Note: Status Register Bits are reset by a read of Status Register.

Figure 8.  $\overline{\text{T\_CRIT\_A}}$  Temperature Response Diagram

### POWER ON RESET DEFAULT STATES

LM99 always powers up to these known default states. The LM99 remains in these states until after the first conversion.

1. Command Register set to 00h
2. Local Temperature set to 0°C
3. Remote Diode Temperature set to 0°C until the end of the first conversion.
4. Status Register set to 00h.
5. Configuration register set to 00h;  $\overline{\text{ALERT}}$  enabled, Remote  $\text{T\_CRIT}$  alarm enabled and Local  $\text{T\_CRIT}$  alarm enabled
6. 85°C Local  $\text{T\_CRIT}$  temperature setpoint
7. 110°C Remote  $\text{T\_CRIT}$  temperature setpoint (126°C Remote diode junction temperature)

8. 70°C Local and Remote HIGH temperature setpoints
9. 0°C Local and Remote LOW temperature setpoints
10. Filter and Alert Configure Register set to 00h; filter disabled,  $\overline{\text{ALERT}}$  output set as an SMBus ALERT
11. Conversion Rate Register set to 8h; conversion rate set to 16 conv./sec.

## SMBus INTERFACE

The LM99 operates as a slave on the SMBus, so the SMBCLK line is an input and the SMBData line is bi-directional. The LM99 never drives the SMBCLK line and it does not support clock stretching. According to SMBus specifications, the LM99 has a 7-bit slave address. All bits A6 through A0 are internally programmed and can not be changed by software or hardware. The LM99 and LM99-1 have the following slave addresses:

| Version | A6 | A5 | A4 | A3 | A2 | A1 | A0 |
|---------|----|----|----|----|----|----|----|
| LM99    | 1  | 0  | 0  | 1  | 1  | 0  | 0  |
| LM99-1  | 1  | 0  | 0  | 1  | 1  | 0  | 1  |

## TEMPERATURE DATA FORMAT

Temperature data can only be read from the Local and Remote Temperature registers; the setpoint registers (T\_CRIT, LOW, HIGH) are read/write.

Remote temperature data is represented by an 11-bit, two's complement word with an LSB (Least Significant Bit) equal to 0.125°C. The data format is a left justified 16-bit word available in two 8-bit registers:

**Table 1. Actual vs. LM99 Remote Temperature Conversion**

| Actual Remote Diode Temperature, °C | LM99 Remote Diode Temperature Register, °C | Binary Results in LM99 Remote Temperature Register | Hex Remote Temperature Register |
|-------------------------------------|--|--|---------------------------------|
| 120                                 | +104                                       | 0110 1000 0000 0000                                | 6800h                           |
| 125                                 | +109                                       | 0110 1101 0000 0000                                | 6D00h                           |
| 126                                 | +110                                       | 0110 1110 0000 0000                                | 7100h                           |
| 130                                 | +114                                       | 0111 0010 0010 0000                                | 7200h                           |
| 135                                 | +119                                       | 0111 0111 0000 0000                                | 7700h                           |
| 140                                 | +124                                       | 0111 1100 0000 0000                                | 7200h                           |

**Table 2. Actual vs. Remote T\_Crit Setpoint**

| Actual Remote Diode T_Crit Setpoint, °C | Factory-Programmed Remote T_CRIT High Setpoint, °C | Binary Remote T_CRIT High Setpoint Value | Hex Remote T_CRIT High Setpoint Value |
|---|--|--|---------------------------------------|
| 126                                     | +110   | 0110 1110                                | 71h                                   |

Local Temperature data is represented by an 8-bit, two's complement byte with an LSB (Least Significant Bit) equal to 1°C:

| Local Temperature | Digital Output |     |
|-------------------|----------------|-----|
|                   | Binary         | Hex |
| +125°C            | 0111 1101      | 7Dh |
| +25°C             | 0001 1001      | 19h |
| +1°C              | 0000 0001      | 01h |
| 0°C               | 0000 0000      | 00h |
| -1°C              | 1111 1111      | FFh |
| -25°C             | 1110 0111      | E7h |
| -55°C             | 1100 1001      | C9h |

## OPEN-DRAIN OUTPUTS

The SMBData,  $\overline{\text{ALERT}}$  and  $\overline{\text{T\_CRIT\_A}}$  outputs are open-drain outputs and do not have internal pull-ups. A “high” level will not be observed on these pins until pull-up current is provided by some external source, typically a pull-up resistor. Choice of resistor value depends on many system factors but, in general, the pull-up resistor should be as large as possible. This will minimize any internal temperature reading errors due to internal heating of the LM99. The maximum resistance of the pull-up to provide a 2.1V high level, based on LM99 specification for High Level Output Current with the supply voltage at 3.0V, is 82 k $\Omega$  (5%) or 88.7 k $\Omega$  (1%).

## DIODE FAULT DETECTION

The LM99 is equipped with operational circuitry designed to detect fault conditions concerning the remote diode. In the event that the D+ pin is detected as shorted to  $V_{DD}$  or floating, the Remote Temperature High Byte (RTHB) register is loaded with +127°C, the Remote Temperature Low Byte (RTLb) register is loaded with 0, and the OPEN bit (D2) in the status register is set. As a result, if the Remote T\_CRIT setpoint register (RCS) is set to a value less than +127°C the  $\overline{\text{ALERT}}$  and T\_Crit output pins will be pulled low, if the Alert Mask and T\_Crit Mask are disabled. If the Remote HIGH Setpoint High Byte Register (RHSb) is set to a value less than +127°C then  $\overline{\text{ALERT}}$  will be pulled low, if the Alert Mask is disabled. The OPEN bit itself will not trigger and ALERT.

In the event that the D+ pin is shorted to ground or D–, the Remote Temperature High Byte (RTHB) register is loaded with –128°C (1000 0000) and the OPEN bit (D2) in the status register will not be set. Since operating the LM99 at –128°C is beyond its operational limits, this temperature reading represents this shorted fault condition. If the value in the Remote Low Setpoint High Byte Register (RLSb) is more than –128°C and the Alert Mask is disabled,  $\overline{\text{ALERT}}$  will be pulled low.

Remote diode temperature sensors that have been previously released and are competitive with the LM99 output a code of 0°C if the external diode is short-circuited. This change is an improvement that allows a reading of 0°C to be truly interpreted as a genuine 0°C reading and not a fault condition.

## COMMUNICATING WITH THE LM99

The data registers in the LM99 are selected by the Command Register. At power-up the Command Register is set to “00”, the location for the Read Local Temperature Register. The Command Register latches the last location it was set to. Each data register in the LM99 falls into one of four types of user accessibility:

1. Read only
2. Write only
3. Read/Write same address
4. Read/Write different address

A **Write** to the LM99 will always include the address byte and the command byte. A write to any register requires one data byte.

**Reading** the LM99 can take place either of two ways:

1. If the location latched in the Command Register is correct (most of the time it is expected that the Command Register will point to one of the Read Temperature Registers because that will be the data most frequently read from the LM99), then the read can simply consist of an address byte, followed by retrieving the data byte.
2. If the Command Register needs to be set, then an address byte, command byte, repeat start, and another address byte will accomplish a read.

The data byte has the most significant bit first. At the end of a read, the LM99 can accept either Acknowledge or No Acknowledge from the Master (No Acknowledge is typically used as a signal for the slave that the Master has read its last byte). It takes the LM99 31.25 ms to measure the temperature of the remote diode and internal diode. When retrieving all 10 bits from a previous remote diode temperature measurement, the master must insure that all 10 bits are from the same temperature conversion. This may be achieved by using one-shot mode or by setting the conversion rate and monitoring the busy bit such that no conversion occurs in between reading the MSB and LSB of the last temperature conversion.

## SMBus Timing Diagrams

### LM99 Timing Diagram

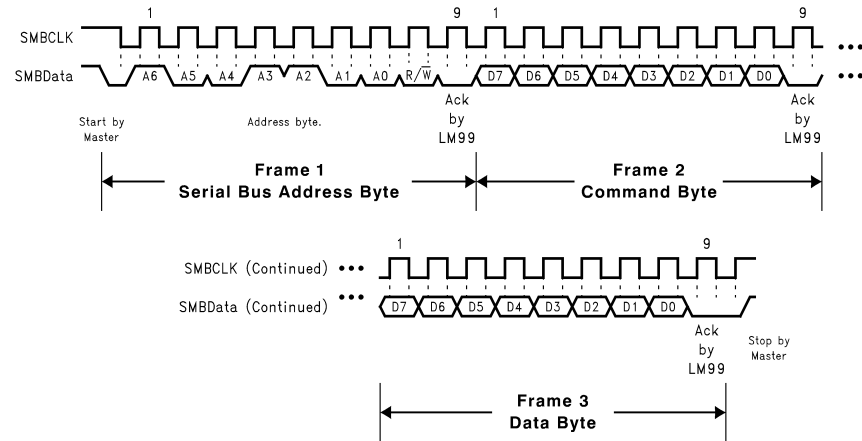

Figure 9. Serial Bus Write to the internal Command Register followed by a the Data Byte

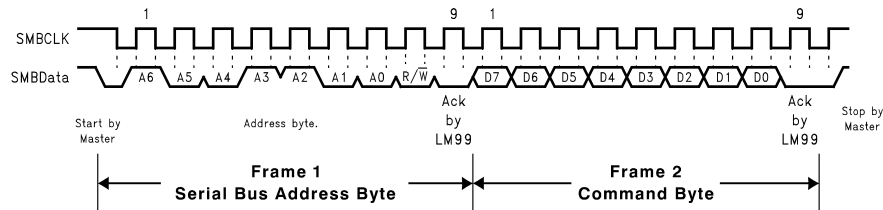

Figure 10. Serial Bus Write to the Internal Command Register

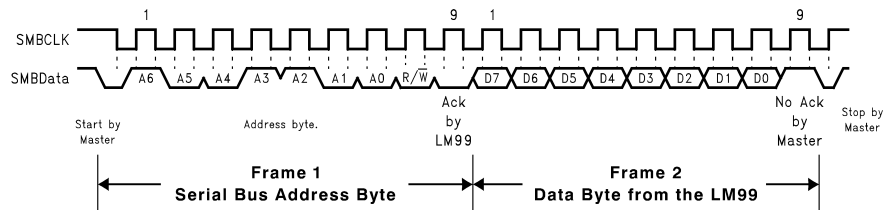

Figure 11. Serial Bus Read from a Register with the Internal Command Register preset to desired value.

## SERIAL INTERFACE RESET

In the event that the SMBus Master is RESET while the LM99 is transmitting on the SMBData line, the LM99 must be returned to a known state in the communication protocol. This may be done in one of two ways:

1. When SMBData is LOW, the LM99 SMBus state machine resets to the SMBus idle state if either SMBData or SMBCLK are held low for more than 35 ms ( $t_{\text{TIMEOUT}}$ ). Note that according to SMBus specification 2.0 all devices are to timeout when either the SMBCLK or SMBData lines are held low for 25-35 ms. Therefore, to insure a timeout of all devices on the bus the SMBCLK or SMBData lines must be held low for at least 35 ms.
2. When SMBData is HIGH, have the master initiate an SMBus start. The LM99 will respond properly to an SMBus start condition at any point during the communication. After the start the LM99 will expect an SMBus Address address byte.

**DIGITAL FILTER**

| D2 | D1 | Filter    |
|----|----|-----------|
| 0  | 0  | No Filter |
| 0  | 1  | Level 1   |
| 1  | 0  | Level 1   |
| 1  | 1  | Level 2   |

In order to suppress erroneous remote temperature readings due to noise, the LM99 incorporates a user-configured digital filter. The filter is accessed in the FILTER and ALERT CONFIGURE REGISTER at BFh. The filter can be set according to the table shown.

Level 2 sets maximum filtering.

Filter Output Response to a Step Input depict the filter output to in response to a step input and an impulse input. Figure 14 depicts the digital filter in use in a Pentium 4 processor system. Note that the two curves, with filter and without, have been purposely offset so that both responses can be clearly seen. Inserting the filter does not induce an offset as shown.

**Filter Output Response to a Step Input**

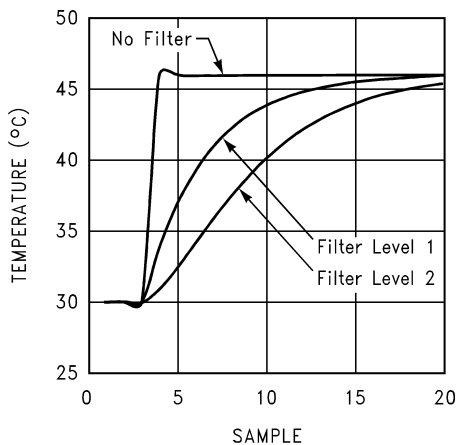

Figure 12. Step Response

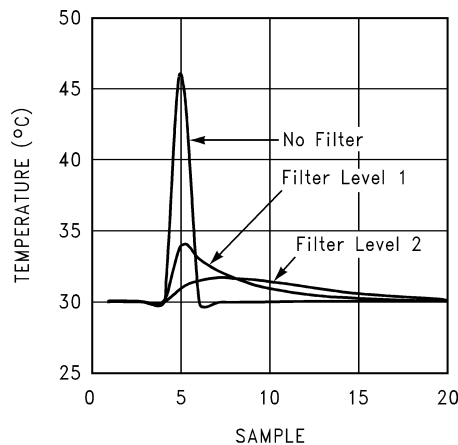
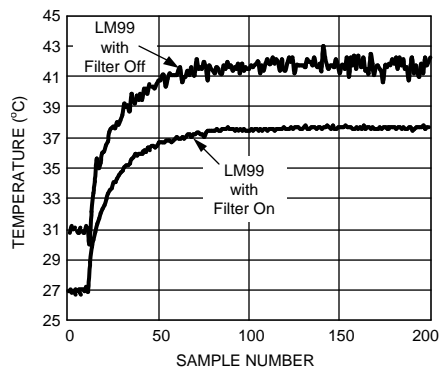

Figure 13. Impulse Response



The filter on and off curves were purposely offset to better show noise performance.

Figure 14. Digital Filter Response in a Pentium 4 processor System

## FAULT QUEUE

In order to suppress erroneous ALERT or T\_CRIT triggering the LM99 incorporates a Fault Queue. The Fault Queue acts to insure a remote temperature measurement is genuinely beyond a HIGH, LOW or T\_CRIT setpoint by not triggering until three consecutive out of limit measurements have been made, see [Figure 15](#). The fault queue defaults off upon power-on and may be activated by setting bit D0 in the Configuration register (09h) to “1”.

## ONE-SHOT REGISTER

The One-Shot register is used to initiate a single conversion and comparison cycle when the device is in standby mode, after which the device returns to standby. This is not a data register and it is the write operation that causes the one-shot conversion. The data written to this address is irrelevant and is not stored. A zero will always be read from this register.

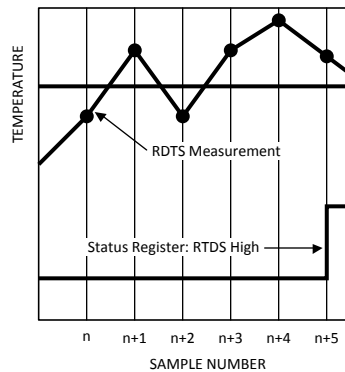

Figure 15. Fault Queue Temperature Response Diagram

## LM99 Registers

### COMMAND REGISTER

Selects which registers will be read from or written to. Data for this register should be transmitted during the Command Byte of the SMBus write communication.

| P7             | P6 | P5 | P4 | P3 | P2 | P1 | P0 |
|----------------|----|----|----|----|----|----|----|
| Command Select |    |    |    |    |    |    |    |

P0-P7: Command Select

| Command Select Address      |                              | Power On Default State |                     | Register Name | Register Function  |
|-----------------------------|------------------------------|------------------------|---------------------|---------------|--|
| Read Address<br><P7:P0> hex | Write Address<br><P7:P0> hex | <D7:D0> binary         | <D7:D0> decimal     |               |  |
| 00h                         | NA                           | 0000 0000              | 0                   | LT            | Local Temperature  |
| 01h                         | NA                           | 0000 0000              | 0                   | RTHB          | Remote Temperature High Byte                                 |
| 02h                         | NA                           | 0000 0000              | 0                   | SR            | Status Register  |
| 03h                         | 09h                          | 0000 0000              | 0                   | C             | Configuration  |
| 04h                         | 0Ah                          | 0000 1000              | 8 (16<br>conv./sec) | CR            | Conversion Rate  |
| 05h                         | 0Bh                          | 0100 0110              | 70                  | LHS           | Local HIGH Setpoint  |
| 06h                         | 0Ch                          | 0000 0000              | 0                   | LLS           | Local LOW Setpoint   |
| 07h                         | 0Dh                          | 0100 0110              | 70                  | RHSHB         | Remote HIGH Setpoint High Byte                               |
| 08h                         | 0Eh                          | 0000 0000              | 0                   | RLSHB         | Remote LOW Setpoint High Byte                                |
| NA                          | 0Fh                          |                        |                     | One Shot      | Writing to this register will initiate a one shot conversion |



| Command Select Address      |                              | Power On Default State             |                 | Register Name | Register Function                   |
|-----------------------------|------------------------------|------------------------------------|-----------------|---------------|-------------------------------------|
| Read Address<br><P7:P0> hex | Write Address<br><P7:P0> hex | <D7:D0> binary                     | <D7:D0> decimal |               |                                     |
| 10h                         | NA                           | 0000 0000                          | 0               | RTLB          | Remote Temperature Low Byte         |
| 11h                         | 11h                          | 0000 0000                          | 0               | RTOHB         | Remote Temperature Offset High Byte |
| 12h                         | 12h                          | 0000 0000                          | 0               | RTOLB         | Remote Temperature Offset Low Byte  |
| 13h                         | 13h                          | 0000 0000                          | 0               | RHSLB         | Remote HIGH Setpoint Low Byte       |
| 14h                         | 14h                          | 0000 0000                          | 0               | RLSLB         | Remote LOW Setpoint Low Byte        |
| 19h                         | 19h                          | 0110 1110                          | 110             | RCS           | Remote T_CRIT Setpoint              |
| 20h                         | 20h                          | 0101 0101                          | 85              | LCS           | Local T_CRIT Setpoint               |
| 21h                         | 21h                          | 0000 1010                          | 10              | TH            | T_CRIT Hysteresis                   |
| B0h-BEh                     | B0h-BEh                      |                                    |                 |               | Manufacturers Test Registers        |
| BFh                         | BFh                          | 0000 0000                          | 0               | RDTF          | Remote Diode Temperature Filter     |
| FEh                         | NA                           | 0000 0001                          | 1               | RMD           | Read Manufacturer's ID              |
| FFh                         | NA                           | LM99 0011 0001<br>LM99-1 0011 0100 | 49<br>52        | RDR           | Read Stepping or Die Revision Code  |

### LOCAL and REMOTE TEMPERATURE REGISTERS (LT, RTHB, RTLB)

**Table 3. (Read Only Address 00h, 01h):**

| BIT   | D7   | D6 | D5 | D4 | D3 | D2 | D1 | D0 |
|-------|------|----|----|----|----|----|----|----|
| Value | SIGN | 64 | 32 | 16 | 8  | 4  | 2  | 1  |

For LT and RTHB D7–D0: Temperature Data. LSB = 1°C. Two's complement format.

**Table 4. (Read Only Address 10h):**

| BIT   | D7  | D6   | D5    | D4 | D3 | D2 | D1 | D0 |
|-------|-----|------|-------|----|----|----|----|----|
| Value | 0.5 | 0.25 | 0.125 | 0  | 0  | 0  | 0  | 0  |

For RTLB D7–D5: Temperature Data. LSB = 0.125°C. Two's complement format.

The maximum value available from the Local Temperature register is 127; the minimum value available from the Local Temperature register is -128. The maximum value available from the Remote Temperature register is 127.875; the minimum value available from the Remote Temperature registers is -128.875.

Note that the remote diode junction temperature is actually 16°C higher than the Remote Temperature Register value.

### STATUS REGISTER (SR)

**Table 5. (Read Only Address 02h):**

| D7   | D6    | D5   | D4    | D3   | D2   | D1    | D0    |
|------|-------|------|-------|------|------|-------|-------|
| Busy | LHIGH | LLOW | RHIGH | RLOW | OPEN | RCRIT | LCRIT |

Power up default is with all bits "0" (zero).

D0: LCRIT: When set to "1" indicates a Local Critical Temperature alarm.

D1: RCRIT: When set to "1" indicates a Remote Diode Critical Temperature alarm.

D2: OPEN: When set to "1" indicates a Remote Diode disconnect.

D3: RLOW: When set to "1" indicates a Remote Diode LOW Temperature alarm

D4: RHIGH: When set to "1" indicates a Remote Diode HIGH Temperature alarm.

D5: LLOW: When set to "1" indicates a Local LOW Temperature alarm.

D6: LHIGH: When set to “1” indicates a Local HIGH Temperature alarm.

D7: Busy: When set to “1” ADC is busy converting.

## CONFIGURATION REGISTER

**Table 6. (Read Address 03h / Write Address 09h):**

| D7                             | D6                           | D5 | D4   | D3 | D2  | D1 | D0          |
|--------------------------------|------------------------------|----|--|----|---|----|-------------|
| $\overline{\text{ALERT}}$ mask | $\overline{\text{RUN/STOP}}$ | 0  | Remote $\overline{\text{T\_CRIT\_A}}$ mask | 0  | Local $\overline{\text{T\_CRIT\_A}}$ mask | 0  | Fault Queue |

Power up default is with all bits “0” (zero)

D7:  $\overline{\text{ALERT}}$  mask: When set to “1”  $\overline{\text{ALERT}}$  interrupts are masked.

D6: RUN/STOP: When set to “1” SHUTDOWN is enabled.

D5: is not defined and defaults to “0”.

D4: Remote  $\overline{\text{T\_CRIT\_A}}$  mask: When set to “1” a diode temperature reading that exceeds  $\overline{\text{T\_CRIT\_A}}$  setpoint will not activate the  $\overline{\text{T\_CRIT\_A}}$  pin.

D3: is not defined and defaults to “0”.

D2: Local  $\overline{\text{T\_CRIT\_A}}$  mask: When set to “1” a Local temperature reading that exceeds  $\overline{\text{T\_CRIT\_A}}$  setpoint will not activate the  $\overline{\text{T\_CRIT\_A}}$  pin.

D1: is not defined and defaults to “0”.

D0: Fault Queue: when set to “1” three consecutive remote temperature measurements outside the HIGH, LOW, or T\_CRIT setpoints will trigger an “Outside Limit” condition resulting in setting of status bits and associated output pins..

## CONVERSION RATE REGISTER

**Table 7. (Read Address 04h / Write Address 0Ah)**

| Value  | Conversion Rate |
|--------|-----------------|
| 00     | 62.5 mHz        |
| 01     | 125 mHz         |
| 02     | 250 mHz         |
| 03     | 500 mHz         |
| 04     | 1 Hz            |
| 05     | 2 Hz            |
| 06     | 4 Hz            |
| 07     | 8 Hz            |
| 08     | 16 Hz           |
| 09     | 32 Hz           |
| 10-255 | Undefined       |

## LOCAL and REMOTE HIGH SETPOINT REGISTERS (LHS, RSHSB, and RHSLB)

**Table 8. (Read Address 05h, 07h / Write Address 0Bh, 0Dh):**

| BIT   | D7   | D6 | D5 | D4 | D3 | D2 | D1 | D0 |
|-------|------|----|----|----|----|----|----|----|
| Value | SIGN | 64 | 32 | 16 | 8  | 4  | 2  | 1  |

For LHS and RSHSB: HIGH setpoint temperature data. Power-on default is LHIGH = RHIGH = 70°C. 1 LSB = 1°C. Two's complement format.

**Table 9. (RHSLB) (Read / Write Address 13h):**

| BIT   | D7  | D6   | D5    | D4 | D3 | D2 | D1 | D0 |
|-------|-----|------|-------|----|----|----|----|----|
| Value | 0.5 | 0.25 | 0.125 | 0  | 0  | 0  | 0  | 0  |

For RHSLB: Remote HIGH Setpoint Low Byte temperature data. Power-on default is 0°C. 1 LSB = 0.125°C. Two's complement format.

**LOCAL and REMOTE LOW SETPOINT REGISTERS (LLS, RLSHB, and RLSLB)**
**Table 10. (Read Address 06h, 08h, / Write Address 0Ch, 0Eh):**

| BIT   | D7   | D6 | D5 | D4 | D3 | D2 | D1 | D0 |
|-------|------|----|----|----|----|----|----|----|
| Value | SIGN | 64 | 32 | 16 | 8  | 4  | 2  | 1  |

For LLS and RLSHB: HIGH setpoint temperature data. Power-on default is LHIGH = RHIGH = 0°C. 1 LSB = 1°C. Two's complement format.

**Table 11. (Read / Write Address 14h):**

| BIT   | D7  | D6   | D5    | D4 | D3 | D2 | D1 | D0 |
|-------|-----|------|-------|----|----|----|----|----|
| Value | 0.5 | 0.25 | 0.125 | 0  | 0  | 0  | 0  | 0  |

For RLSLB: Remote HIGH Setpoint Low Byte temperature data. Power-on default is 0°C. 1 LSB = 0.125°C. Two's complement format.

**REMOTE TEMPERATURE OFFSET REGISTERS (RTOHB and RTOLB)**
**Table 12. (Read / Write Address 11h):**

| BIT   | D7   | D6 | D5 | D4 | D3 | D2 | D1 | D0 |
|-------|------|----|----|----|----|----|----|----|
| Value | SIGN | 64 | 32 | 16 | 8  | 4  | 2  | 1  |

For RTOHB: Remote Temperature Offset High Byte. Power-on default is LHIGH = RHIGH = 0°C. 1 LSB = 1°C. Two's complement format.

**Table 13. (Read / Write Address 12h):**

| BIT   | D7  | D6   | D5    | D4 | D3 | D2 | D1 | D0 |
|-------|-----|------|-------|----|----|----|----|----|
| Value | 0.5 | 0.25 | 0.125 | 0  | 0  | 0  | 0  | 0  |

For RTOLB: Remote Temperature Offset High Byte. Power-on default is 0°C. 1 LSB = 0.125°C. Two's complement format.

The offset value written to these registers will automatically be added to or subtracted from the remote temperature measurement that will be reported in the Remote Temperature registers.

**LOCAL and REMOTE T\_CRIT REGISTERS (RCS and LCS)**
**Table 14. (Read / Write Address 20h, 19h):**

| BIT   | D7   | D6 | D5 | D4 | D3 | D2 | D1 | D0 |
|-------|------|----|----|----|----|----|----|----|
| Value | SIGN | 64 | 32 | 16 | 8  | 4  | 2  | 1  |

D7–D0: T\_CRIT setpoint temperature data. Local power-on default is T\_CRIT = 85°C. Remote power-on default is T\_CRIT = 110°C (+126°C actual remote diode temperature). 1 LSB = 1°C, two's complement format.

**T\_CRIT HYSTERESIS REGISTER (TH)**
**Table 15. (Read and Write Address 21h):**

| BIT   | D7 | D6 | D5 | D4 | D3 | D2 | D1 | D0 |
|-------|----|----|----|----|----|----|----|----|
| Value |    |    |    | 16 | 8  | 4  | 2  | 1  |

D7–D0: T\_CRIT Hysteresis temperature. Power-on default is TH = 10°C. 1 LSB = 1°C, maximum value = 31.

### FILTER and ALERT CONFIGURE REGISTER

**Table 16. (Read and Write Address BFh):**

| BIT   | D7 | D6 | D5 | D4 | D3 | D2           | D1 | D0              |
|-------|----|----|----|----|----|--------------|----|-----------------|
| Value | 0  | 0  | 0  | 0  | 0  | Filter Level |    | ALERT Configure |

D7-D3: is not defined defaults to "0".

D2-D1: input filter setting as defined the table below:

| D2 | D1 | Filter Level |
|----|----|--------------|
| 0  | 0  | No Filter    |
| 0  | 1  | Level 1      |
| 1  | 0  | Level 1      |
| 1  | 1  | Level 2      |

Level 2 sets maximum filtering.

D0: when set to "1" comparator mode is enabled.

### MANUFACTURERS ID REGISTER

(Read Address FEh) Default value 01h.

### DIE REVISION CODE REGISTER

(Read Address FFh) The LM99 version has a default value 31h or 49 decimal. The LM99-1 version has a default value of 34h or 52 decimal. This register will increment by 1 every time there is a revision to the die by Texas Instruments.

### Application Hints

The LM99 can be applied easily in the same way as other integrated-circuit temperature sensors, and its remote diode sensing capability allows it to be used in new ways as well. It can be soldered to a printed circuit board, and because the path of best thermal conductivity is between the die and the pins, its temperature will effectively be that of the printed circuit board lands and traces soldered to the LM99's pins. This presumes that the ambient air temperature is almost the same as the surface temperature of the printed circuit board; if the air temperature is much higher or lower than the surface temperature, the actual temperature of the of the LM99 die will be at an intermediate temperature between the surface and air temperatures. Again, the primary thermal conduction path is through the leads, so the circuit board temperature will contribute to the die temperature much more strongly than will the air temperature.

To measure temperature external to the LM99's die, use a remote diode. This diode can be located on the die of a target IC, allowing measurement of the IC's temperature, independent of the LM99's temperature. The LM99 has been optimized to measure the NVIDIA GeForceFX family thermal diode. Remember that a discrete diode's temperature will be affected, and often dominated, by the temperature of its leads.

## DIODE NON-IDEALITY

### Diode Non-Ideality Factor Effect on Accuracy

When a transistor is connected as a diode, the following relationship holds for variables  $V_{BE}$ ,  $T$  and  $I_f$ :

$$I_f = I_S \left[ e^{\frac{V_{be}}{\eta V_t}} - 1 \right]$$

where

- $V_t = \frac{kT}{q}$
  - $q = 1.6 \times 10^{-19}$  Coulombs (the electron charge),
  - $T =$  Absolute Temperature in Kelvin
  - $k = 1.38 \times 10^{-23}$  joules/K (Boltzmann's constant),
  - $\eta$  is the non-ideality factor of the process the diode is manufactured on,
  - $I_S =$  Saturation Current and is process dependent,
  - $I_f =$  Forward Current through the base-emitter junction
  - $V_{BE} =$  Base-Emitter Voltage drop
- (1)

In the active region, the -1 term is negligible and may be eliminated, yielding the following equation

$$I_f = I_S \left[ e^{\frac{V_{be}}{\eta V_t}} \right]$$
(2)

In the above equation,  $\eta$  and  $I_S$  are dependant upon the process that was used in the fabrication of the particular diode. By forcing two currents with a very controlled ratio ( $N$ ) and measuring the resulting voltage difference, it is possible to eliminate the  $I_S$  term. Solving for the forward voltage difference yields the relationship:

$$V_{be} = \eta \frac{kT}{q} \ln(N)$$
(3)

The voltage seen by the LM99 also includes the  $I_f R_S$  voltage drop of the series resistance. The non-ideality factor,  $\eta$ , is the only other parameter not accounted for and depends on the diode that is used for measurement. Since  $\Delta V_{BE}$  is proportional to both  $\eta$  and  $T$ , the variations in  $\eta$  cannot be distinguished from variations in temperature. Since the non-ideality factor is not controlled by the temperature sensor, it will directly add to the inaccuracy of the sensor. As an example, assume a temperature sensor has an accuracy specification of  $\pm 1^\circ\text{C}$  at room temperature of  $25^\circ\text{C}$  and the process used to manufacture the diode has a non-ideality variation of  $\pm 0.1\%$ . The resulting accuracy of the temperature sensor at room temperature will be:

$$T_{ACC} = \pm 1^\circ\text{C} + (\pm 0.1\% \text{ of } 298 \text{ }^\circ\text{K}) = \pm 1.4^\circ\text{C}$$
(4)

The additional inaccuracy in the temperature measurement caused by  $\eta$ , can be eliminated if each temperature sensor is calibrated with the remote diode that it will be paired with.

### Compensating for Diode Non-Ideality

In order to compensate for the errors introduced by non-ideality, the temperature sensor is calibrated for a particular processor. Texas Instruments temperature sensors are always calibrated to the typical non-ideality of a given processor type. The LM99 is calibrated for the non-ideality of the NVIDIA GeForceFX family thermal diode. When a temperature sensor calibrated for a particular processor type is used with a different processor type or a given processor type has a non-ideality that strays from the typical, errors are introduced.

Temperature errors associated with non-ideality may be reduced in a specific temperature range of concern through use of the offset registers (11h and 12h). See [Table 17](#) below.

**Table 17. Offset Register Settings for Specific Devices**

| Processor Family                    | Offset Register Settings |              |              |
|-------------------------------------|--------------------------|--------------|--------------|
|                                     | $\Delta T$ , °C          | Register 11h | Register 12h |
| NVIDIA GeForceFX Graphics Processor | default                  | default      | default      |
| Intel Pentium 4 Processor           | +2.625                   | 0000 0010    | 1010 0000    |
| Intel Pentium 3 Processor           | +2.375                   | 0000 0010    | 0110 0000    |

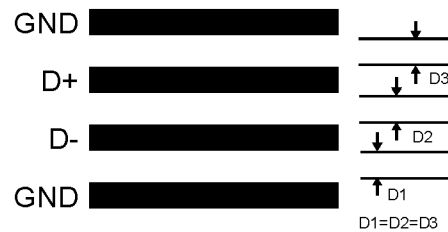
**PCB LAYOUT FOR MINIMIZING NOISE****Figure 16. Ideal Diode Trace Layout**

In a noisy environment, such as a processor mother board, layout considerations are very critical. Noise induced on traces running between the remote temperature diode sensor and the LM99 can cause temperature conversion errors. Keep in mind that the signal level the LM99 is trying to measure is in microvolts. The following guidelines should be followed:

1. Place a 0.1  $\mu\text{F}$  power supply bypass capacitor as close as possible to the  $V_{\text{DD}}$  pin and the recommended 2.2 nF capacitor as close as possible to the LM99's D+ and D- pins. Make sure the traces to the 2.2 nF capacitor are matched.
2. Ideally, the LM99 should be placed within 10 cm of the Processor diode pins with the traces being as straight, short and identical as possible. Trace resistance of 1  $\Omega$  can cause as much as 1°C of error. This error can be compensated by using the Remote Temperature Offset Registers, since the value placed in these registers will automatically be subtracted from or added to the remote temperature reading.
3. Diode traces should be surrounded by a GND guard ring to either side, above and below if possible. This GND guard should not be between the D+ and D- lines. In the event that noise does couple to the diode lines it would be ideal if it is coupled common mode. That is equally to the D+ and D- lines.
4. Avoid routing diode traces in close proximity to power supply switching or filtering inductors.
5. Avoid running diode traces close to or parallel to high speed digital and bus lines. Diode traces should be kept at least 2 cm apart from the high speed digital traces.
6. If it is necessary to cross high speed digital traces, the diode traces and the high speed digital traces should cross at a 90 degree angle.
7. The ideal place to connect the LM99's GND pin is as close as possible to the Processors GND associated with the sense diode.
8. Leakage current between D+ and GND should be kept to a minimum. One nano-ampere of leakage can cause as much as 1°C of error in the diode temperature reading. Keeping the printed circuit board as clean as possible will minimize leakage current.

Noise coupling into the digital lines greater than 400 mVp-p (typical hysteresis) and undershoot less than 500 mV below GND, may prevent successful SMBus communication with the LM99. SMBus no acknowledge is the most common symptom, causing unnecessary traffic on the bus. Although the SMBus maximum frequency of communication is rather low (100 kHz max), care still needs to be taken to ensure proper termination within a system with multiple parts on the bus and long printed circuit board traces. An RC lowpass filter with a 3 dB corner frequency of about 40 MHz is included on the LM99's SMBCLK input. Additional resistance can be added in series with the SMBData and SMBCLK lines to further help filter noise and ringing. Minimize noise coupling by keeping digital traces out of switching power supply areas as well as ensuring that digital lines containing high speed data communications cross at right angles to the SMBData and SMBCLK lines.

---

**REVISION HISTORY**

| <b>Changes from Revision C (March 2013) to Revision D</b>  | <b>Page</b>              |
|--|--------------------------|
| <hr/> <ul style="list-style-type: none"><li>• Changed layout of National Data Sheet to TI format .....</li></ul> | <hr/> <a href="#">22</a> |

**PACKAGING INFORMATION**

| Orderable Device | Status<br>(1) | Package Type | Package Drawing | Pins | Package Qty | Eco Plan<br>(2) | Lead finish/<br>Ball material<br>(6) | MSL Peak Temp<br>(3) | Op Temp (°C) | Device Marking<br>(4/5) | Samples                 |
|------------------|---------------|--------------|-----------------|------|-------------|-----------------|--------------------------------------|----------------------|--------------|-------------------------|-------------------------|
| LM99-1C1MM/NOPB  | ACTIVE        | VSSOP        | DGK             | 8    | 1000        | RoHS & Green    | SN                                   | Level-1-260C-UNLIM   | 0 to 85      | T20C                    | <a href="#">Samples</a> |
| LM99C1MM/NOPB    | OBSOLETE      | VSSOP        | DGK             | 8    |             | TBD             | Call TI                              | Call TI              | 0 to 85      | T17C                    |                         |
| LM99C1MMX/NOPB   | ACTIVE        | VSSOP        | DGK             | 8    | 3500        | RoHS & Green    | SN                                   | Level-1-260C-UNLIM   | 0 to 85      | T17C                    | <a href="#">Samples</a> |

(1) The marketing status values are defined as follows:

**ACTIVE:** Product device recommended for new designs.

**LIFEBUY:** TI has announced that the device will be discontinued, and a lifetime-buy period is in effect.

**NRND:** Not recommended for new designs. Device is in production to support existing customers, but TI does not recommend using this part in a new design.

**PREVIEW:** Device has been announced but is not in production. Samples may or may not be available.

**OBSOLETE:** TI has discontinued the production of the device.

(2) **RoHS:** TI defines "RoHS" to mean semiconductor products that are compliant with the current EU RoHS requirements for all 10 RoHS substances, including the requirement that RoHS substance do not exceed 0.1% by weight in homogeneous materials. Where designed to be soldered at high temperatures, "RoHS" products are suitable for use in specified lead-free processes. TI may reference these types of products as "Pb-Free".

**RoHS Exempt:** TI defines "RoHS Exempt" to mean products that contain lead but are compliant with EU RoHS pursuant to a specific EU RoHS exemption.

**Green:** TI defines "Green" to mean the content of Chlorine (Cl) and Bromine (Br) based flame retardants meet JS709B low halogen requirements of <=1000ppm threshold. Antimony trioxide based flame retardants must also meet the <=1000ppm threshold requirement.

(3) MSL, Peak Temp. - The Moisture Sensitivity Level rating according to the JEDEC industry standard classifications, and peak solder temperature.

(4) There may be additional marking, which relates to the logo, the lot trace code information, or the environmental category on the device.

(5) Multiple Device Markings will be inside parentheses. Only one Device Marking contained in parentheses and separated by a "~" will appear on a device. If a line is indented then it is a continuation of the previous line and the two combined represent the entire Device Marking for that device.

(6) Lead finish/Ball material - Orderable Devices may have multiple material finish options. Finish options are separated by a vertical ruled line. Lead finish/Ball material values may wrap to two lines if the finish value exceeds the maximum column width.

**Important Information and Disclaimer:**The information provided on this page represents TI's knowledge and belief as of the date that it is provided. TI bases its knowledge and belief on information provided by third parties, and makes no representation or warranty as to the accuracy of such information. Efforts are underway to better integrate information from third parties. TI has taken and continues to take reasonable steps to provide representative and accurate information but may not have conducted destructive testing or chemical analysis on incoming materials and chemicals. TI and TI suppliers consider certain information to be proprietary, and thus CAS numbers and other limited information may not be available for release.



In no event shall TI's liability arising out of such information exceed the total purchase price of the TI part(s) at issue in this document sold by TI to Customer on an annual basis.

**TAPE AND REEL INFORMATION**

**QUADRANT ASSIGNMENTS FOR PIN 1 ORIENTATION IN TAPE**

\*All dimensions are nominal

| Device          | Package Type | Package Drawing | Pins | SPQ  | Reel Diameter (mm) | Reel Width W1 (mm) | A0 (mm) | B0 (mm) | K0 (mm) | P1 (mm) | W (mm) | Pin1 Quadrant |
|-----------------|--------------|-----------------|------|------|--------------------|--------------------|---------|---------|---------|---------|--------|---------------|
| LM99-1C1MM/NOPB | VSSOP        | DGK             | 8    | 1000 | 178.0              | 12.4               | 5.3     | 3.4     | 1.4     | 8.0     | 12.0   | Q1            |
| LM99C1MMX/NOPB  | VSSOP        | DGK             | 8    | 3500 | 330.0              | 12.4               | 5.3     | 3.4     | 1.4     | 8.0     | 12.0   | Q1            |

## TAPE AND REEL BOX DIMENSIONS



\*All dimensions are nominal

| Device          | Package Type | Package Drawing | Pins | SPQ  | Length (mm) | Width (mm) | Height (mm) |
|-----------------|--------------|-----------------|------|------|-------------|------------|-------------|
| LM99-1C1MM/NOPB | VSSOP        | DGK             | 8    | 1000 | 208.0       | 191.0      | 35.0        |
| LM99C1MMX/NOPB  | VSSOP        | DGK             | 8    | 3500 | 367.0       | 367.0      | 35.0        |

DGK0008A



# PACKAGE OUTLINE

VSSOP - 1.1 mm max height

SMALL OUTLINE PACKAGE



NOTES:

PowerPAD is a trademark of Texas Instruments.

1. All linear dimensions are in millimeters. Any dimensions in parenthesis are for reference only. Dimensioning and tolerancing per ASME Y14.5M.
2. This drawing is subject to change without notice.
3. This dimension does not include mold flash, protrusions, or gate burrs. Mold flash, protrusions, or gate burrs shall not exceed 0.15 mm per side.
4. This dimension does not include interlead flash. Interlead flash shall not exceed 0.25 mm per side.
5. Reference JEDEC registration MO-187.

# EXAMPLE BOARD LAYOUT

DGK0008A

™ VSSOP - 1.1 mm max height

SMALL OUTLINE PACKAGE



LAND PATTERN EXAMPLE  
EXPOSED METAL SHOWN  
SCALE: 15X



SOLDER MASK DETAILS

4214862/A 04/2023

NOTES: (continued)

6. Publication IPC-7351 may have alternate designs.
7. Solder mask tolerances between and around signal pads can vary based on board fabrication site.
8. Vias are optional depending on application, refer to device data sheet. If any vias are implemented, refer to their locations shown on this view. It is recommended that vias under paste be filled, plugged or tented.
9. Size of metal pad may vary due to creepage requirement.

# EXAMPLE STENCIL DESIGN

DGK0008A

<sup>TM</sup> VSSOP - 1.1 mm max height

SMALL OUTLINE PACKAGE



SOLDER PASTE EXAMPLE  
SCALE: 15X

4214862/A 04/2023

NOTES: (continued)

11. Laser cutting apertures with trapezoidal walls and rounded corners may offer better paste release. IPC-7525 may have alternate design recommendations.
12. Board assembly site may have different recommendations for stencil design.

## IMPORTANT NOTICE AND DISCLAIMER

TI PROVIDES TECHNICAL AND RELIABILITY DATA (INCLUDING DATA SHEETS), DESIGN RESOURCES (INCLUDING REFERENCE DESIGNS), APPLICATION OR OTHER DESIGN ADVICE, WEB TOOLS, SAFETY INFORMATION, AND OTHER RESOURCES "AS IS" AND WITH ALL FAULTS, AND DISCLAIMS ALL WARRANTIES, EXPRESS AND IMPLIED, INCLUDING WITHOUT LIMITATION ANY IMPLIED WARRANTIES OF MERCHANTABILITY, FITNESS FOR A PARTICULAR PURPOSE OR NON-INFRINGEMENT OF THIRD PARTY INTELLECTUAL PROPERTY RIGHTS.

These resources are intended for skilled developers designing with TI products. You are solely responsible for (1) selecting the appropriate TI products for your application, (2) designing, validating and testing your application, and (3) ensuring your application meets applicable standards, and any other safety, security, regulatory or other requirements.

These resources are subject to change without notice. TI grants you permission to use these resources only for development of an application that uses the TI products described in the resource. Other reproduction and display of these resources is prohibited. No license is granted to any other TI intellectual property right or to any third party intellectual property right. TI disclaims responsibility for, and you will fully indemnify TI and its representatives against, any claims, damages, costs, losses, and liabilities arising out of your use of these resources.

TI's products are provided subject to [TI's Terms of Sale](#) or other applicable terms available either on [ti.com](https://www.ti.com) or provided in conjunction with such TI products. TI's provision of these resources does not expand or otherwise alter TI's applicable warranties or warranty disclaimers for TI products.

TI objects to and rejects any additional or different terms you may have proposed.

Mailing Address: Texas Instruments, Post Office Box 655303, Dallas, Texas 75265  
Copyright © 2024, Texas Instruments Incorporated