

www.ti.com

SINGLE-SUPPLY, RAIL-TO-RAIL OPERATIONAL AMPLIFIERS

microAmplifier™ Series

FEATURES

- RAIL-TO-RAIL INPUT/OUTPUT
- MICRO SIZE PACKAGES
- WIDE BANDWIDTH: 5.5MHz
- HIGH SLEW RATE: 6V/μs
- LOW THD+NOISE: 0.0007% (f = 1kHz)
- LOW QUIESCENT CURRENT: 850μA/chan
- SINGLE, DUAL, AND QUAD VERSIONS

APPLICATIONS

- DRIVING A/D CONVERTERS
- PCMCIA CARDS
- DATA ACQUISITION
- AUDIO PROCESSING
- COMMUNICATIONS
- ACTIVE FILTERS
- TEST EQUIPMENT

DESCRIPTION

OPA343 series rail-to-rail CMOS operational amplifiers are designed for low-cost, miniature applications. They are optimized for low-voltage, single-supply operation. Rail-to-rail input/output and high-speed operation make them ideal for driving sampling Analog-to-Digital (A/D) converters. They are also well suited for general-purpose and audio applications as well as providing I/V conversion at the output of Digital-to-Analog (D/A) converters. Single, dual, and quad versions have identical specifications for design flexibility.

The OPA343 series operates on a single supply as low as 2.5V, and input common-mode voltage range extends 500mV beyond the supply rails. Output voltage swings to within 1mV of the supply rails with a 100kΩ load. They offer excellent dynamic response (BW = 5.5MHz, SR = 6V/μs), yet quiescent current is only 850μA. Dual and quad designs feature completely independent circuitry for lowest crosstalk and freedom from interaction.

The single (OPA343) packages are the tiny SOT-23-5 surface mount and SO-8 surface mount. The dual (OPA2343) comes in the miniature MSOP-8 surface mount and SO-8 surface mount. The quad (OPA4343) packages are the space-saving SSOP-16 surface mount, SO-14 surface mount, and TSSOP-14 surface mount. All are specified from -40°C to +85°C and operate from -55°C to +125°C. A SPICE macromodel is available for design analysis.

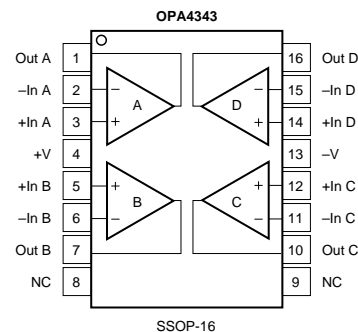
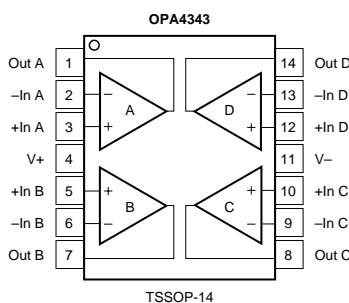
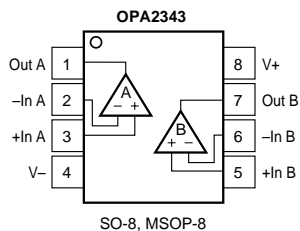
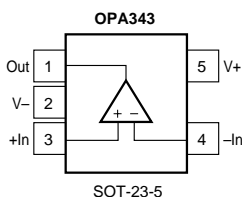
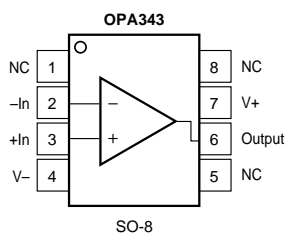

SPECIFICATIONS: $V_S = 2.7V$ to $5.5V$

Boldface limits apply over the specified temperature range, $T_A = -40^{\circ}C$ to $+85^{\circ}C$. $V_S = 5V$.

At $T_A = +25^{\circ}C$, $R_L = 10k\Omega$ connected to $V_S/2$ and $V_{OUT} = V_S/2$, unless otherwise noted.

PARAMETER	CONDITION	OPA343NA, UA OPA2343EA, UA OPA4343EA, UA, NA			UNITS
		MIN	TYP ⁽¹⁾	MAX	
OFFSET VOLTAGE Input Offset Voltage vs Temperature vs Power Supply Over Temperature Channel Separation, dc	V_{OS} dV_{OS}/dT PSRR	$V_S = 5V$ $V_S = 2.7V$ to $5.5V$, $V_{CM} = 0V$ $V_S = 2.7V$ to $5.5V$, $V_{CM} = 0V$	 ±2 ±3 40 0.2	 ±8 200 200	 mV $\mu V/^{\circ}C$ $\mu V/V$ $\mu V/V$ $\mu V/V$
INPUT BIAS CURRENT Input Bias Current Over Temperature Input Offset Current	I_B I_{OS}		 ±0.2 ±0.2	 ±10 ±60 ±10	 pA pA pA
NOISE Input Voltage Noise, $f = 0.1$ to $50kHz$ Input Voltage Noise Density, $f = 1kHz$ Current Noise Density, $f = 1kHz$	 e_n i_n		 8 25 3		 μV_{rms} nV/\sqrt{Hz} fA/\sqrt{Hz}
INPUT VOLTAGE RANGE Common-Mode Voltage Range Common-Mode Rejection Ratio	V_{CM} CMRR	 $-0.3V < V_{CM} < (V+) - 1.8V$ $V_S = 5V$, $-0.3V < V_{CM} < 5.3V$ $V_S = 2.7V$, $-0.3V < V_{CM} < 3V$	 -0.3 74 60 54	 (V+) + 0.3	 V dB dB dB
INPUT IMPEDANCE Differential Common-Mode			 $10^{13} \parallel 3$ $10^{13} \parallel 6$		 $\Omega \parallel pF$ $\Omega \parallel pF$
OPEN-LOOP GAIN Open-Loop Voltage Gain Over Temperature Over Temperature Over Temperature	A_{OL}	 $R_L = 100k\Omega$, $5mV < V_O < (V+) - 5mV$ $R_L = 100k\Omega$, $5mV < V_O < (V+) - 5mV$ $R_L = 10k\Omega$, $50mV < V_O < (V+) - 50mV$ $R_L = 10k\Omega$, $50mV < V_O < (V+) - 50mV$ $R_L = 2k\Omega$, $200mV < V_O < (V+) - 200mV$ $R_L = 2k\Omega$, $200mV < V_O < (V+) - 200mV$	 100 100 100 100 92 92	 120 117 110	 dB dB dB dB dB dB
FREQUENCY RESPONSE Gain-Bandwidth Product Slew Rate Settling Time, 0.1% 0.01% Overload Recovery Time Total Harmonic Distortion + Noise	GBW SR THD+N	 $G = 1$ $V_S = 5V$, $G = 1$, $C_L = 100pF$ $V_S = 5V$, 2V Step, $C_L = 100pF$ $V_S = 5V$, 2V Step, $C_L = 100pF$ $V_{IN} \cdot G = V_S$ $V_S = 5V$, $V_O = 3Vp-p^{(2)}$, $G = 1$, $f = 1kHz$	 5.5 6 1 1.6 0.2 0.0007	 MHz $V/\mu s$ μs μs μs %	
OUTPUT Voltage Output Swing from Rail ⁽³⁾ Over Temperature Over Temperature Over Temperature Short-Circuit Current Capacitive Load Drive	 I_{SC} C_{LOAD}	 $R_L = 100k\Omega$, $A_{OL} \geq 100dB$ $R_L = 100k\Omega$, $A_{OL} \geq 100dB$ $R_L = 10k\Omega$, $A_{OL} \geq 100dB$ $R_L = 10k\Omega$, $A_{OL} \geq 100dB$ $R_L = 2k\Omega$, $A_{OL} \geq 92dB$ $R_L = 2k\Omega$, $A_{OL} \geq 92dB$	 1 10 40 ±50 See Typical Curve	 5 5 50 50 200 200	 mV mV mV mV mV mV mA
POWER SUPPLY Specified Voltage Range Operating Voltage Range Quiescent Current (per amplifier) Over Temperature	V_S I_Q	 $I_Q = 0$, $V_S = +5V$ $I_Q = 0$, $V_S = +5V$	 2.7 0.85	 2.5 to 5.5 1.25 1.4	 V V mA mA
TEMPERATURE RANGE Specified Range Operating Range Storage Range Thermal Resistance SOT-23-5 Surface Mount MSOP-8 Surface Mount SO-8 Surface Mount SSOP-16 Surface Mount SO-14 Surface Mount TSSOP-14 Surface Mount	 θ_{JA}		 -40 -55 -65	 +85 +125 +150	 $^{\circ}C$ $^{\circ}C$ $^{\circ}C$ $^{\circ}C/W$ $^{\circ}C/W$ $^{\circ}C/W$ $^{\circ}C/W$ $^{\circ}C/W$ $^{\circ}C/W$ $^{\circ}C/W$

NOTES: (1) $V_S = +5V$. (2) $V_{OUT} = 0.25V$ to $3.25V$. (3) Output voltage swings are measured between the output and power supply rails.

ABSOLUTE MAXIMUM RATINGS⁽¹⁾

Supply Voltage	7.5V
Signal Input Terminals, Voltage ⁽²⁾	(V-) -0.5V to (V+) +0.5V
Current ⁽²⁾	10mA
Output Short-Circuit ⁽³⁾	Continuous
Operating Temperature	-55°C to +125°C
Storage Temperature	-65°C to +150°C
Junction Temperature	150°C
Lead Temperature (soldering, 10s)	300°C

NOTES: (1) Stresses above these ratings may cause permanent damage. Exposure to absolute maximum conditions for extended periods may degrade device reliability. (2) Input terminals are diode-clamped to the power supply rails. Input signals that can swing more than 0.5V beyond the supply rails should be current-limited to 10mA or less. (3) Short-circuit to ground, one amplifier per package.



ELECTROSTATIC DISCHARGE SENSITIVITY

This integrated circuit can be damaged by ESD. Burr-Brown recommends that all integrated circuits be handled with appropriate precautions. Failure to observe proper handling and installation procedures can cause damage.

ESD damage can range from subtle performance degradation to complete device failure. Precision integrated circuits may be more susceptible to damage because very small parametric changes could cause the device not to meet its published specifications.

PACKAGE/ORDERING INFORMATION

PRODUCT	PACKAGE	PACKAGE DRAWING NUMBER	SPECIFIED TEMPERATURE RANGE	PACKAGE MARKING	ORDERING NUMBER ⁽¹⁾	TRANSPORT MEDIA
Single OPA343NA " "	5-Lead SOT-23-5 " "	331 " "	-40°C to +85°C " "	B43 " "	OPA343NA/250 OPA343NA/3K	Tape and Reel Tape and Reel
OPA343UA " "	SO-8 Surface-Mount " "	182 " "	-40°C to +85°C " "	OPA343UA " "	OPA343UA OPA343UA/2K5	Rails Tape and Reel
Dual OPA2343EA " "	MSOP-8 Surface-Mount " "	337 " "	-40°C to +85°C " "	C43 " "	OPA2343EA/250 OPA2343EA/2K5	Tape and Reel Tape and Reel
OPA2343UA " "	SO-8 Surface-Mount " "	182 " "	-40°C to +85°C " "	OPA2343UA " "	OPA2343UA OPA2343UA/2K5	Rails Tape and Reel
Quad OPA4343EA " "	SSOP-16 Surface-Mount " "	322 " "	-40°C to +85°C " "	OPA4343EA " "	OPA4343EA/250 OPA4343EA/2K5	Tape and Reel Tape and Reel
OPA4343UA " "	SO-14 Surface-Mount " "	235 " "	-40°C to +85°C " "	OPA4343UA " "	OPA4343UA OPA4343UA/2K5	Rails Tape and Reel
OPA4343NA " "	TSSOP-14 Surface-Mount " "	357 " "	-40°C to +85°C " "	OPA4343NA " "	OPA4343NA/250 OPA4343NA/2K5	Tape and Reel Tape and Reel

NOTE: (1) Models with a slash (/) are available only in Tape and Reel in the quantities indicated (e.g., /2K5 indicates 2500 devices per reel). Ordering 2500 pieces of "OPA2343EA/2K5" will get a single 2500 piece Tape and Reel.

The information provided herein is believed to be reliable; however, BURR-BROWN assumes no responsibility for inaccuracies or omissions. BURR-BROWN assumes no responsibility for the use of this information, and all use of such information shall be entirely at the user's own risk. Prices and specifications are subject to change without notice. No patent rights or licenses to any of the circuits described herein are implied or granted to any third party. BURR-BROWN does not authorize or warrant any BURR-BROWN product for use in life support devices and/or systems.

TYPICAL PERFORMANCE CURVES

At $T_A = +25^\circ\text{C}$, $V_S = +5\text{V}$, and $R_L = 10\text{k}\Omega$ connected to $V_S/2$, unless otherwise noted.

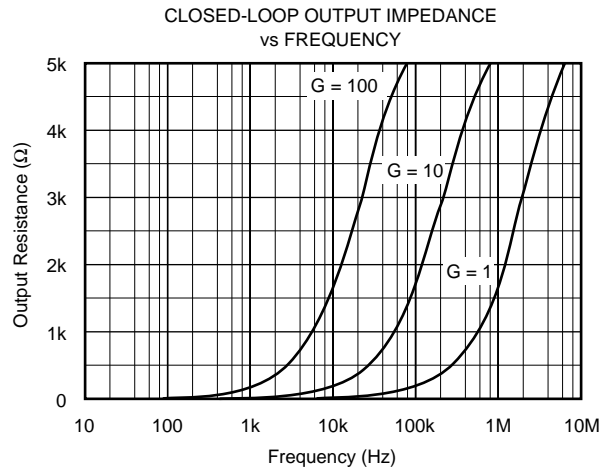
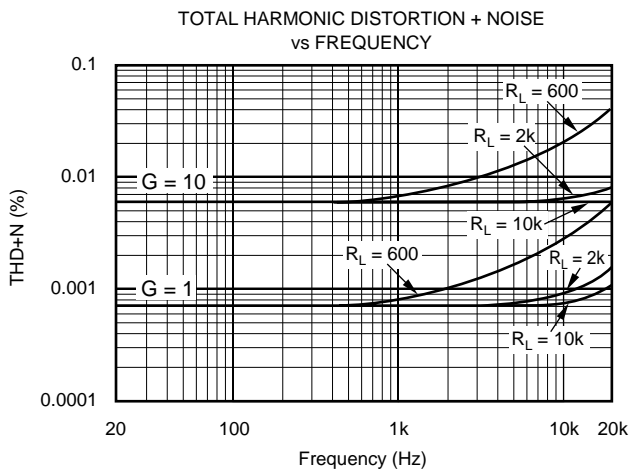
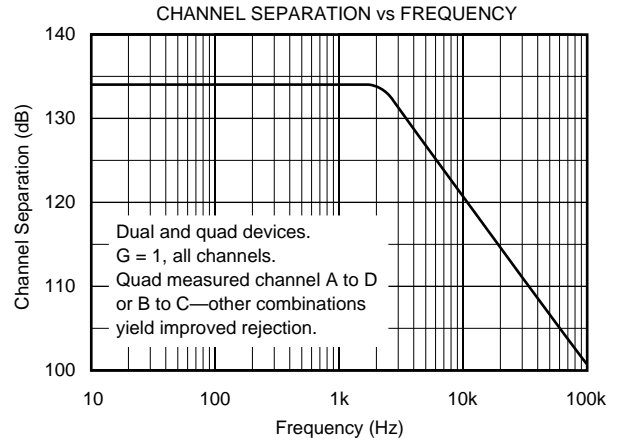
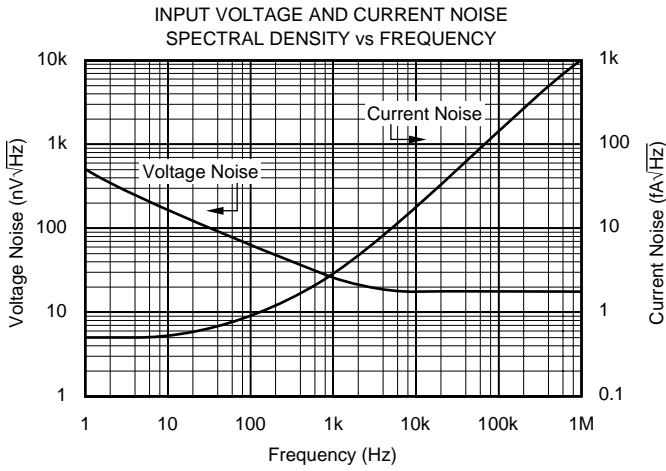
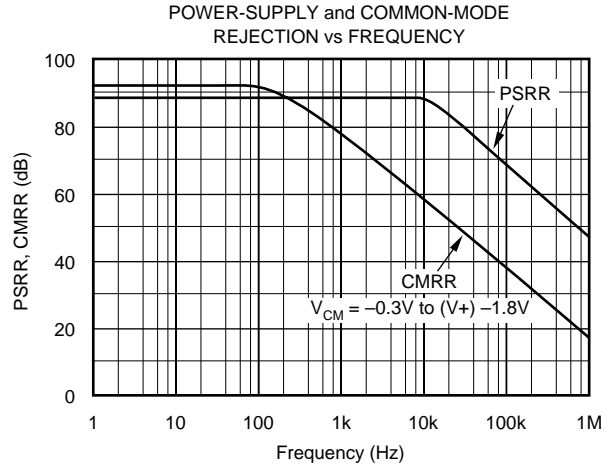
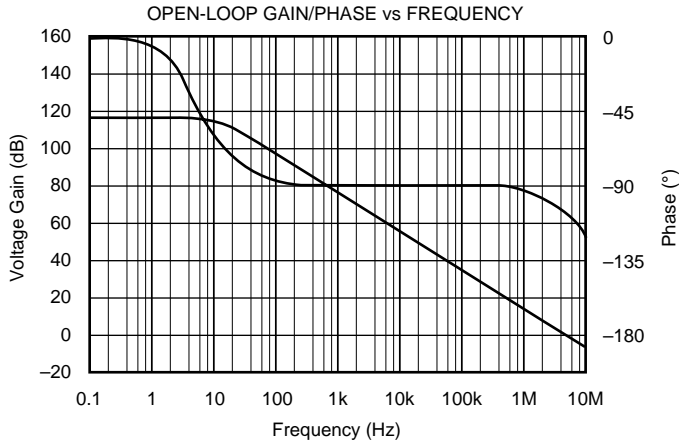

TYPICAL PERFORMANCE CURVES (Cont.)

At $T_A = +25^\circ\text{C}$, $V_S = +5\text{V}$, and $R_L = 10\text{k}\Omega$ connected to $V_S/2$, unless otherwise noted.

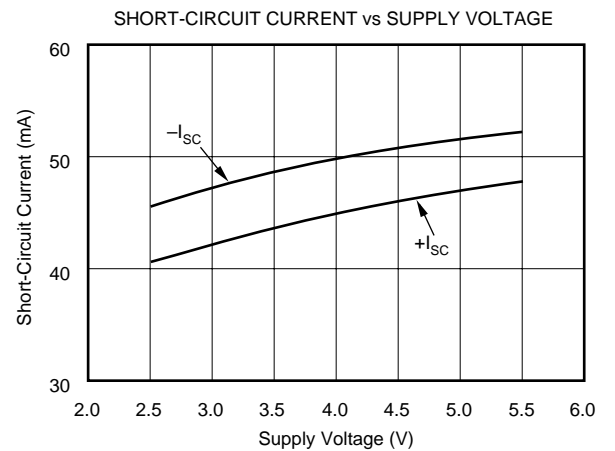
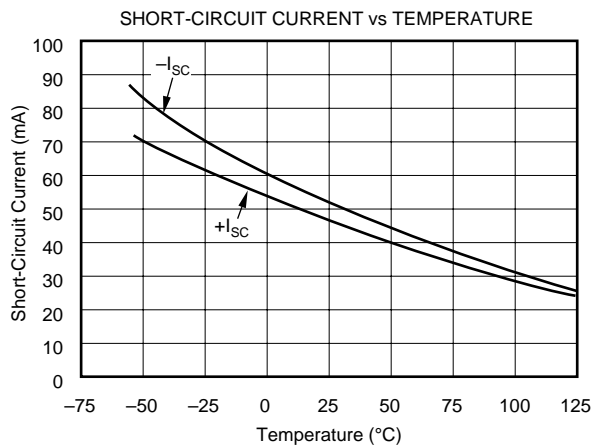
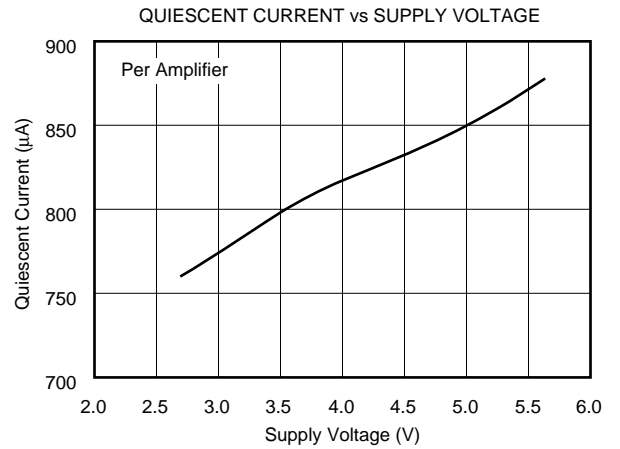
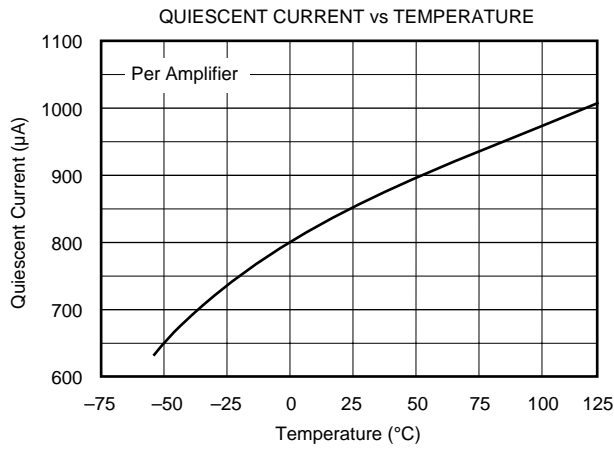
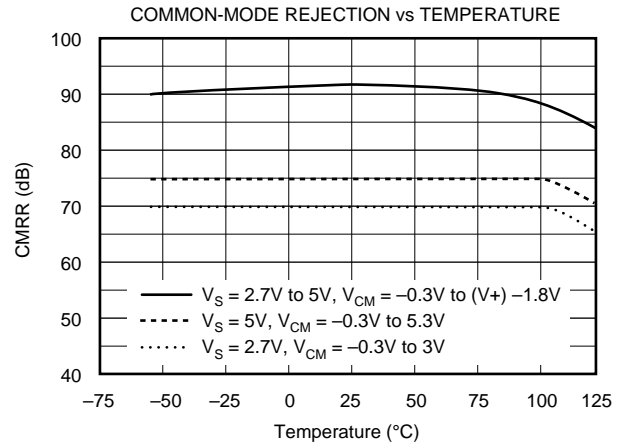
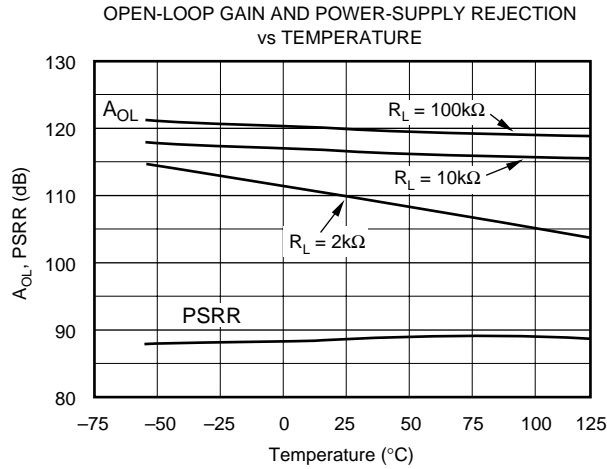

TYPICAL PERFORMANCE CURVES (Cont.)

At $T_A = +25^\circ\text{C}$, $V_S = +5\text{V}$, and $R_L = 10\text{k}\Omega$ connected to $V_S/2$, unless otherwise noted.

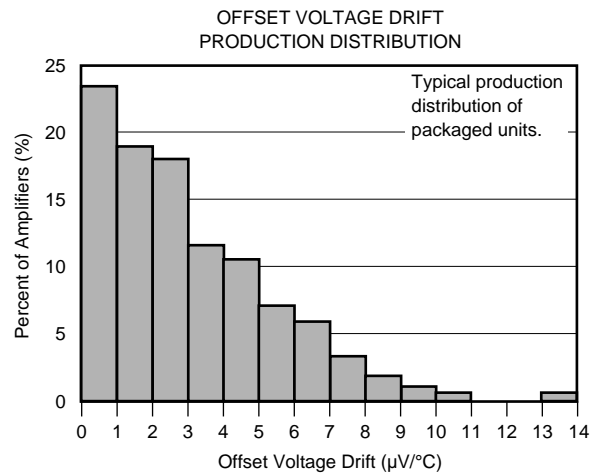
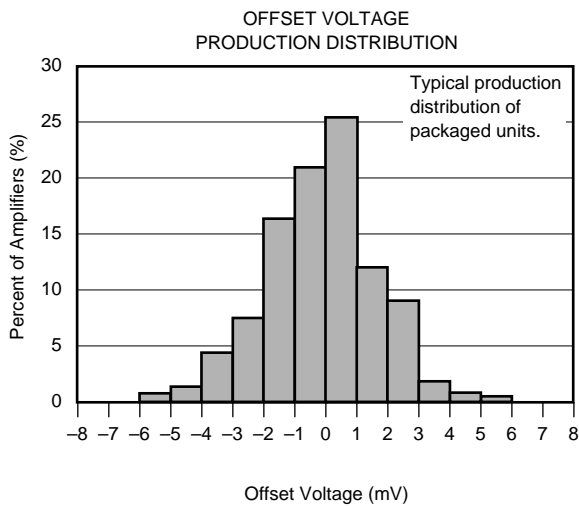
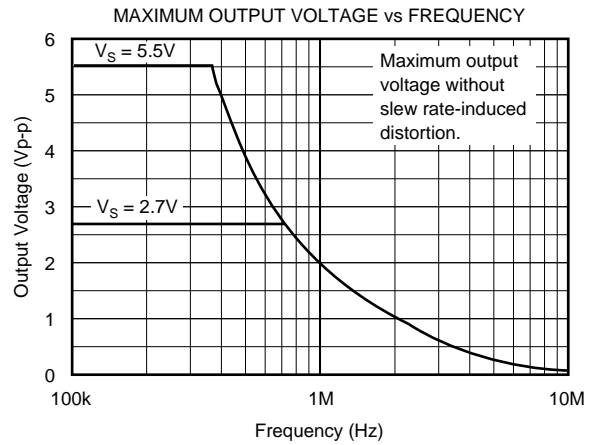
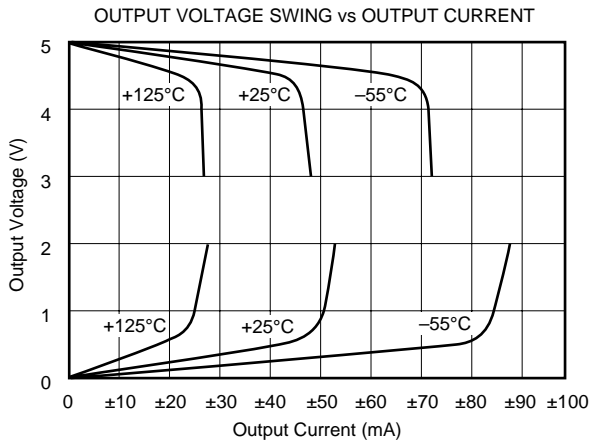
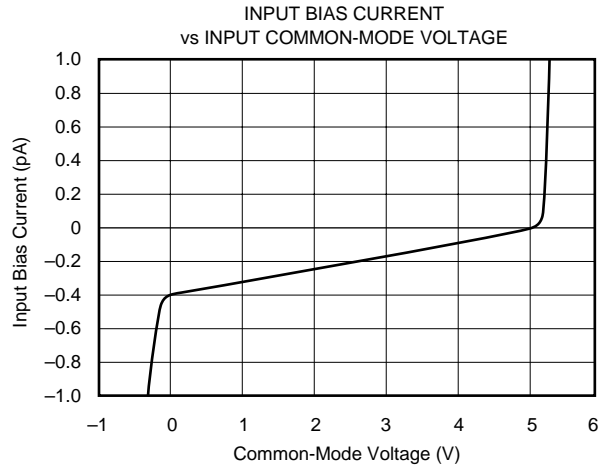
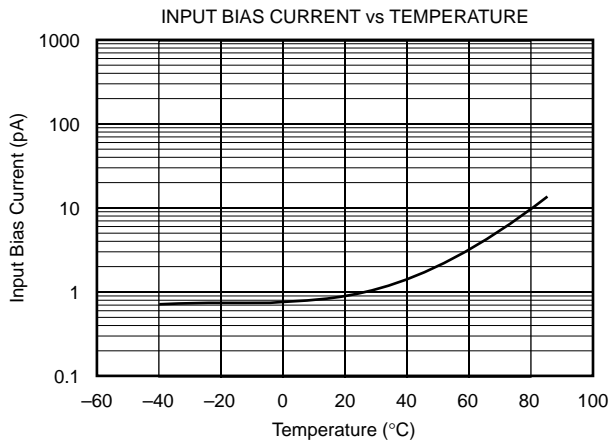

TYPICAL PERFORMANCE CURVES (Cont.)

At $T_A = +25^\circ\text{C}$, $V_S = +5\text{V}$, and $R_L = 10\text{k}\Omega$ connected to $V_S/2$, unless otherwise noted.

SMALL-SIGNAL STEP RESPONSE

$C_L = 100\text{pF}$

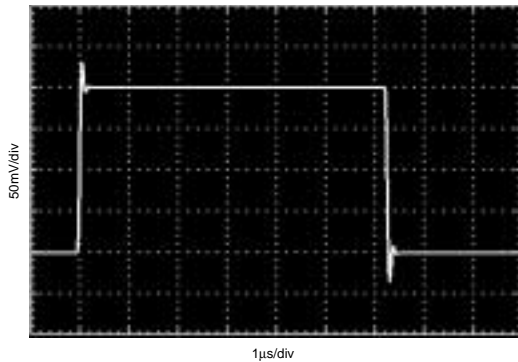

LARGE-SIGNAL STEP RESPONSE

$C_L = 100\text{pF}$

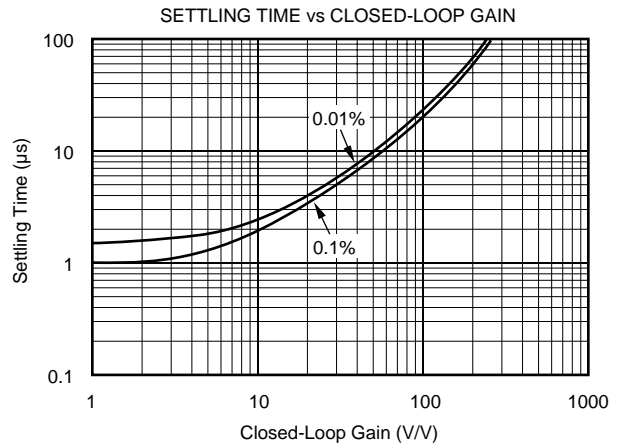
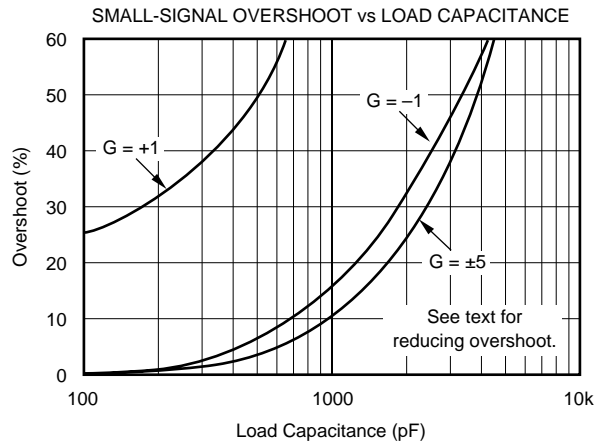
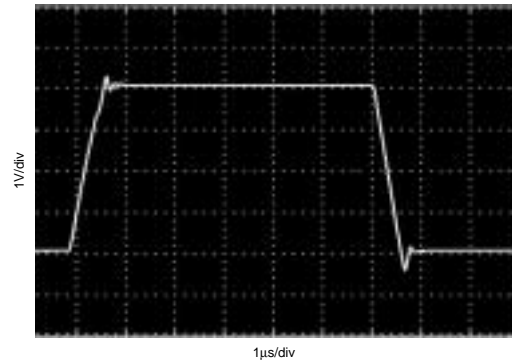

APPLICATIONS INFORMATION

OPA343 series op amps are fabricated on a state-of-the-art 0.6 micron CMOS process. They are unity-gain stable and suitable for a wide range of general-purpose applications. Rail-to-rail input/output make them ideal for driving sampling A/D converters. In addition, excellent ac performance makes them well-suited for audio applications. The class AB output stage is capable of driving 600Ω loads connected to any point between V+ and ground.

Rail-to-rail input and output swing significantly increases dynamic range, especially in low-supply applications. Figure 1 shows the input and output waveforms for the OPA343 in unity-gain configuration. Operation is from a single +5V supply with a 10kΩ load connected to V_S/2. The input is a 5Vp-p sinusoid. Output voltage is approximately 4.98Vp-p.

Power-supply pins should be bypassed with 0.01μF ceramic capacitors.

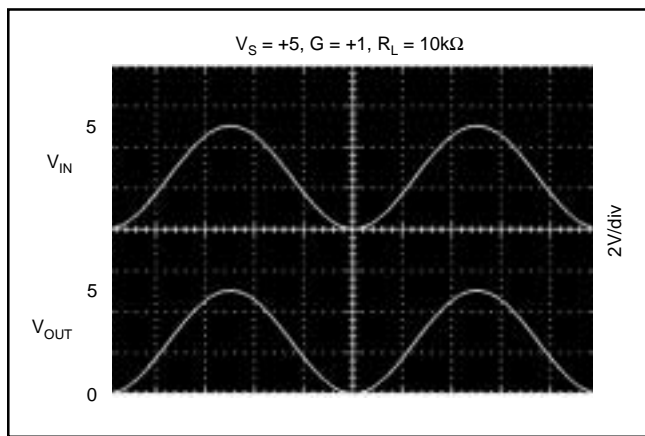

FIGURE 1. Rail-to-Rail Input and Output.

OPERATING VOLTAGE

OPA343 series op amps are fully specified from +2.7V to +5V. However, supply voltage may range from +2.5V to +5.5V. Parameters are guaranteed over the specified supply range—a unique feature of the OPA343 series. In addition, many specifications apply from -40°C to +85°C. Most behavior remains virtually unchanged throughout the full operating voltage range. Parameters which vary significantly with operating voltages or temperature are shown in the Typical Performance Curves.

RAIL-TO-RAIL INPUT

The input common-mode voltage range of the OPA343 series extends 500mV beyond the supply rails. This is achieved with a complementary input stage—an N-channel input differential pair in parallel with a P-channel differential pair, as shown in Figure 2. The N-channel pair is active for input voltages close to the positive rail, typically (V+) - 1.3V to 500mV above the positive supply. The P-channel pair is on for inputs from 500mV below the negative supply to approximately (V+) - 1.3V.

There is a small transition region, typically (V+) - 1.5V to (V+) - 1.1V, in which both input pairs are on. This 400mV transition region can vary ±300mV with process variation. Thus, the transition region (both stages on) can range from (V+) - 1.8V to (V+) - 1.4V on the low end, up to (V+) - 1.2V to (V+) - 0.8V on the high end. Within the 400mV transition region PSRR, CMRR, offset voltage, offset drift, and THD may be degraded compared to operation outside this region.

A double-folded cascode adds the signal from the two input pairs and presents a differential signal to the class AB output stage. Normally, input bias current is approximately 200fA, however, input voltages exceeding the power supplies by

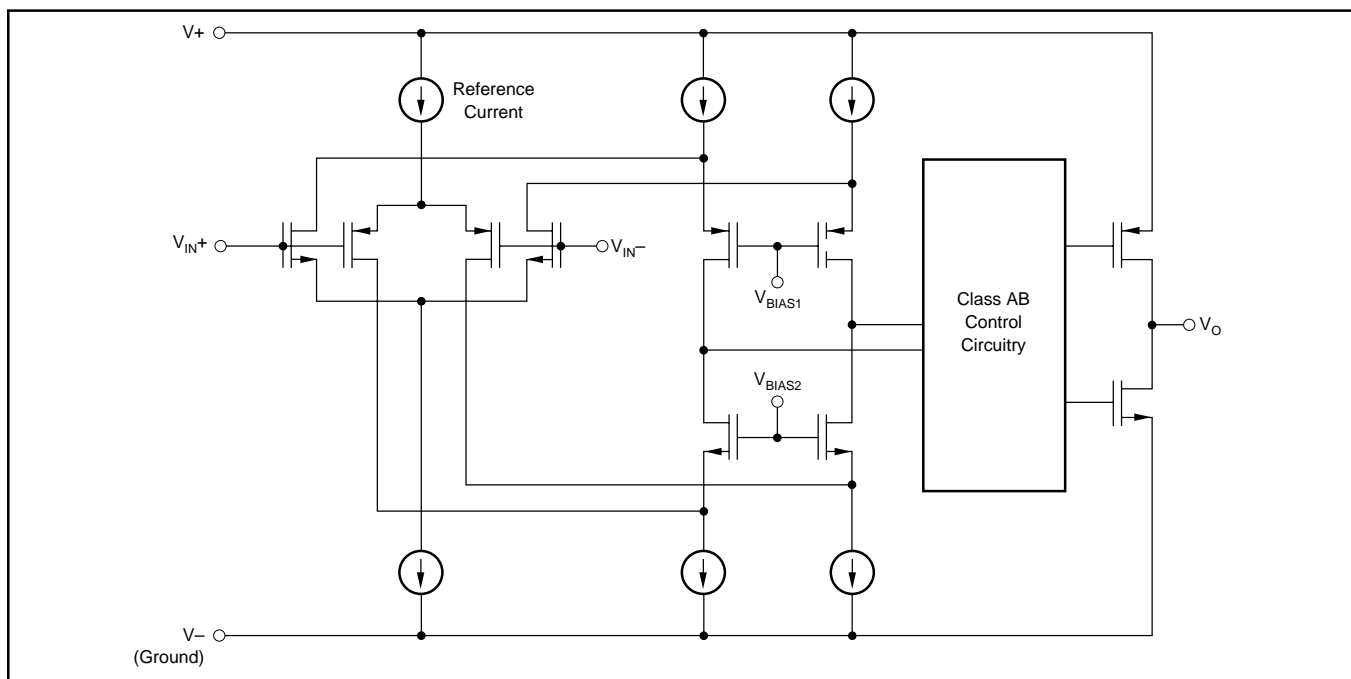

FIGURE 2. Simplified Schematic.

more than 500mV can cause excessive current to flow in or out of the input pins. Momentary voltages greater than 500mV beyond the power supply can be tolerated if the current on the input pins is limited to 10mA. This is easily accomplished with an input resistor, as shown in Figure 3. Many input signals are inherently current-limited to less than 10mA, therefore, a limiting resistor is not required.

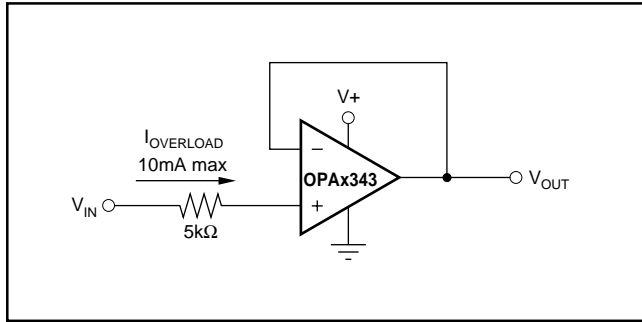

FIGURE 3. Input Current Protection for Voltages Exceeding the Supply Voltage.

RAIL-TO-RAIL OUTPUT

A class AB output stage with common-source transistors is used to achieve rail-to-rail output. For light resistive loads ($>50k\Omega$), the output voltage is typically a few millivolts from the supply rails. With moderate resistive loads ($2k\Omega$ to $50k\Omega$), the output can swing to within a few tens of millivolts from the supply rails and maintain high open-loop gain. See the typical performance curve “Output Voltage Swing vs Output Current.”

CAPACITIVE LOAD AND STABILITY

OPA343 series op amps can drive a wide range of capacitive loads. However, all op amps under certain conditions may become unstable. Op amp configuration, gain, and load value are just a few of the factors to consider when determining stability. An op amp in unity gain configuration is the most susceptible to the effects of capacitive load. The

capacitive load reacts with the op amp’s output resistance, along with any additional load resistance, to create a pole in the small-signal response which degrades the phase margin. In unity gain, OPA343 series op amps perform well, with a pure capacitive load up to approximately 1000pF. Increasing gain enhances the amplifier’s ability to drive more capacitance. See the typical performance curve “Small-Signal Overshoot vs Capacitive Load.”

One method of improving capacitive load drive in the unity gain configuration is to insert a 10Ω to 20Ω resistor in series with the output, as shown in Figure 4. This significantly reduces ringing with large capacitive loads. However, if there is a resistive load in parallel with the capacitive load, R_S creates a voltage divider. This introduces a dc error at the output and slightly reduces output swing. This error may be insignificant. For instance, with $R_L = 10k\Omega$ and $R_S = 20\Omega$, there is only about a 0.2% error at the output.

DRIVING A/D CONVERTERS

OPA343 series op amps are optimized for driving medium speed (up to 100kHz) sampling A/D converters. However, they also offer excellent performance for higher-speed converters. The OPA343 series provides an effective means of buffering the A/D’s input capacitance and resulting charge injection while providing signal gain. For applications requiring high accuracy, the OPA340 series is recommended.

Figures 5 and 6 show the OPA343 driving an ADS7816. The ADS7816 is a 12-bit, micro-power sampling converter in the tiny MSOP-8 package. When used with the miniature package options of the OPA343 series, the combination is ideal for space-limited and low-power applications. For further information consult the ADS7816 data sheet.

With the OPA343 in a noninverting configuration, an RC network at the amplifier’s output can be used to filter high frequency noise in the signal (see Figure 5). In the inverting configuration, filtering may be accomplished with a capacitor across the feedback resistor (see Figure 6).

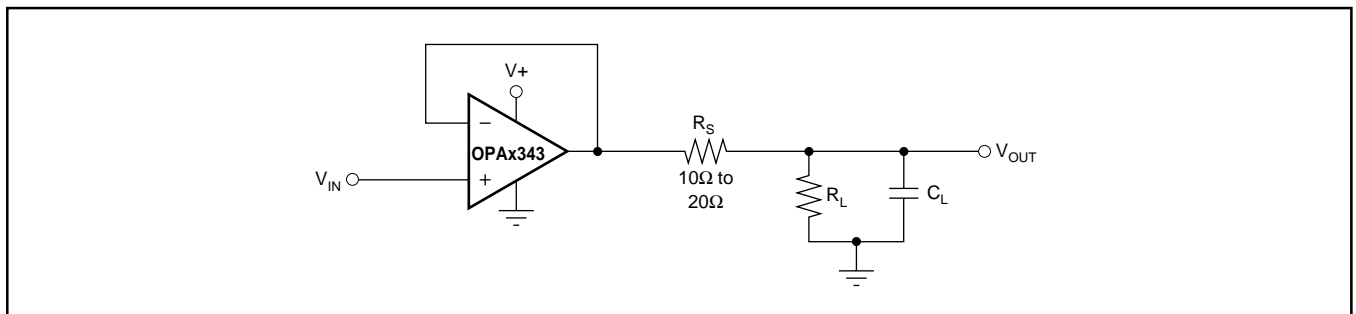

FIGURE 4. Series Resistor in Unity-Gain Configuration Improves Capacitive Load Drive.

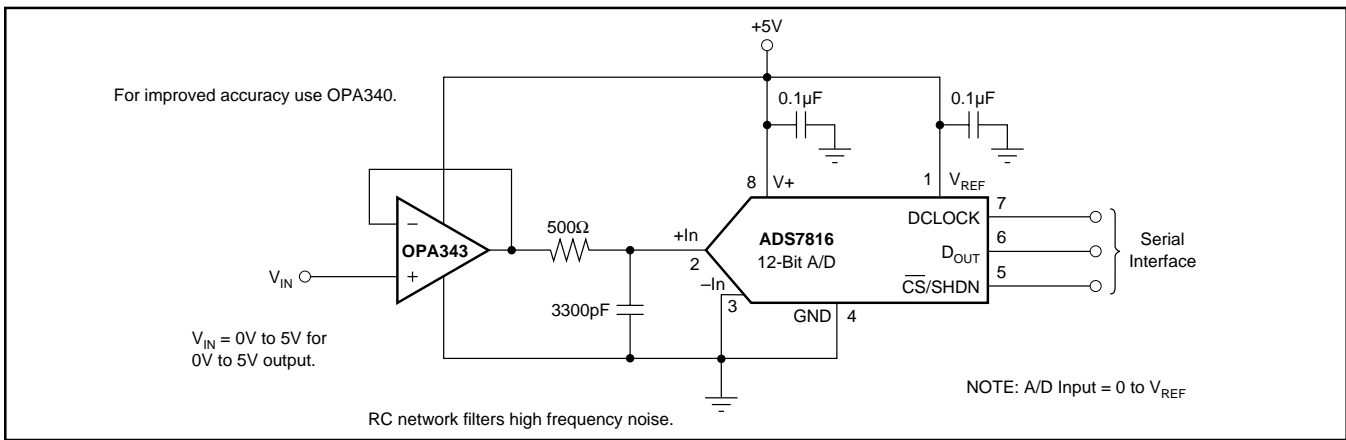

FIGURE 5. OPA343 in Noninverting Configuration Driving ADS7816.

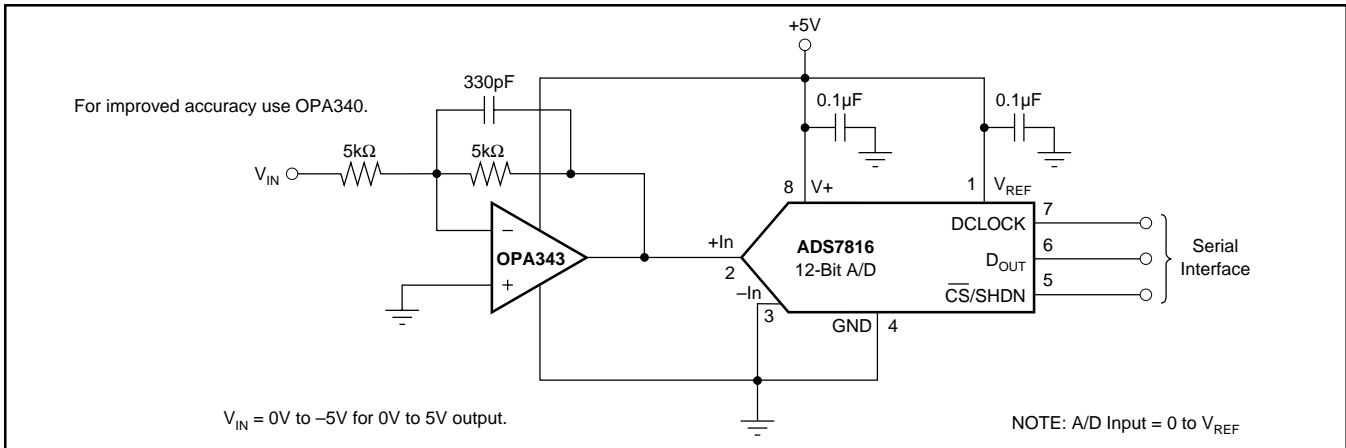

FIGURE 6. OPA343 in Inverting Configuration Driving ADS7816.

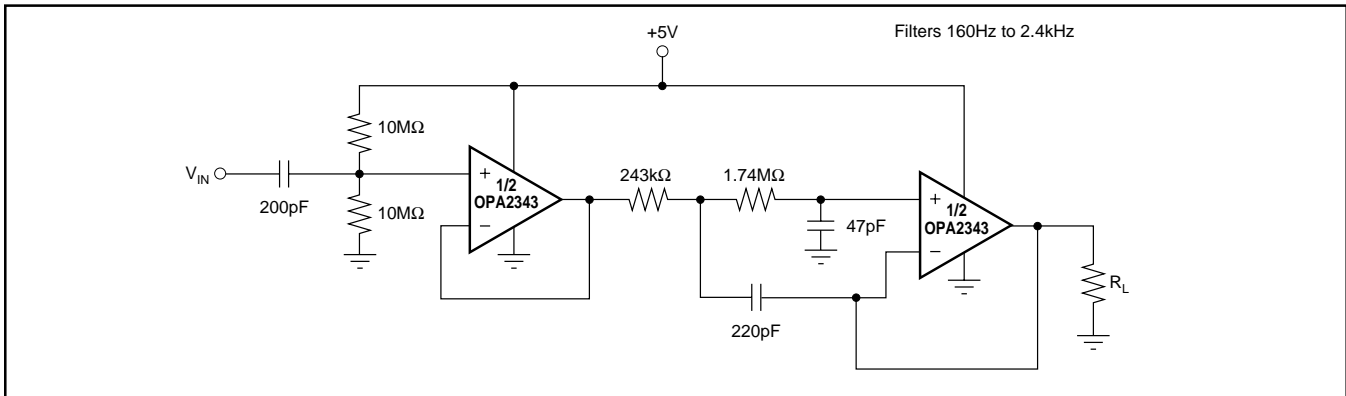

FIGURE 7. Speech Bandpass Filter.

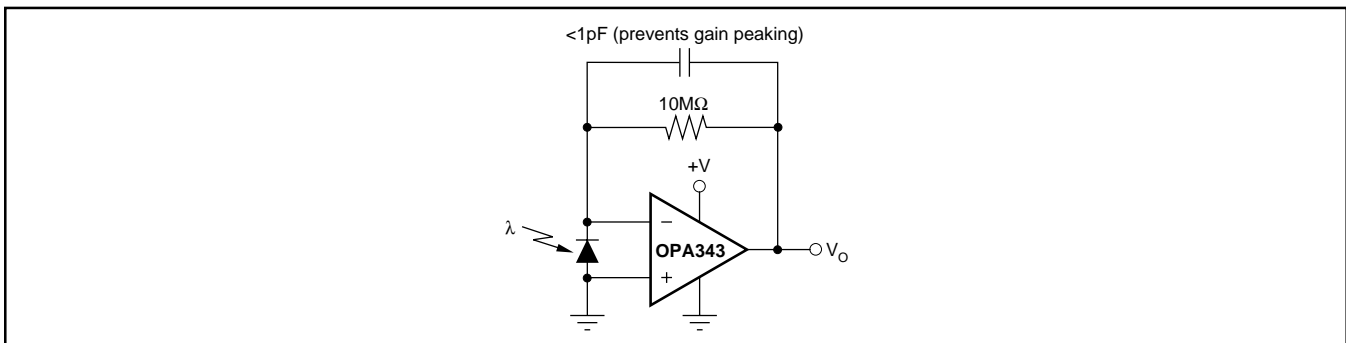

FIGURE 8. Transimpedance Amplifier.

PACKAGING INFORMATION

Orderable Device	Status (1)	Package Type	Package Drawing	Pins	Package Qty	Eco Plan (2)	Lead finish/ Ball material (6)	MSL Peak Temp (3)	Op Temp (°C)	Device Marking (4/5)	Samples
OPA2343EA/250	ACTIVE	VSSOP	DGK	8	250	RoHS & Green	NIPDAUAG SN	Level-2-260C-1 YEAR	-40 to 85	C43	Samples
OPA2343EA/250G4	ACTIVE	VSSOP	DGK	8	250	RoHS & Green	NIPDAUAG	Level-2-260C-1 YEAR	-40 to 85	C43	Samples
OPA2343EA/2K5	ACTIVE	VSSOP	DGK	8	2500	RoHS & Green	NIPDAUAG SN	Level-2-260C-1 YEAR	-40 to 85	C43	Samples
OPA2343EA/2K5G4	ACTIVE	VSSOP	DGK	8	2500	RoHS & Green	NIPDAUAG	Level-2-260C-1 YEAR	-40 to 85	C43	Samples
OPA2343UA	ACTIVE	SOIC	D	8	75	RoHS & Green	NIPDAU	Level-2-260C-1 YEAR	-40 to 85	OPA 2343UA	Samples
OPA2343UA/2K5	ACTIVE	SOIC	D	8	2500	RoHS & Green	NIPDAU	Level-2-260C-1 YEAR	-40 to 85	OPA 2343UA	Samples
OPA343NA/250	ACTIVE	SOT-23	DBV	5	250	RoHS & Green	NIPDAU	Level-1-260C-UNLIM	-40 to 85	B43	Samples
OPA343NA/250G4	ACTIVE	SOT-23	DBV	5	250	RoHS & Green	NIPDAU	Level-1-260C-UNLIM	-40 to 85	B43	Samples
OPA343NA/3K	ACTIVE	SOT-23	DBV	5	3000	RoHS & Green	NIPDAU	Level-1-260C-UNLIM	-40 to 85	B43	Samples
OPA343NA/3KG4	ACTIVE	SOT-23	DBV	5	3000	RoHS & Green	NIPDAU	Level-1-260C-UNLIM	-40 to 85	B43	Samples
OPA343UA	ACTIVE	SOIC	D	8	75	RoHS & Green	NIPDAU	Level-2-260C-1 YEAR	-40 to 85	OPA 343UA	Samples
OPA343UA/2K5	ACTIVE	SOIC	D	8	2500	RoHS & Green	NIPDAU	Level-2-260C-1 YEAR	-40 to 85	OPA 343UA	Samples
OPA4343EA/250	ACTIVE	SSOP	DBQ	16	250	RoHS & Green	NIPDAU	Level-2-260C-1 YEAR	-40 to 85	OPA 4343EA	Samples
OPA4343EA/2K5	ACTIVE	SSOP	DBQ	16	2500	RoHS & Green	NIPDAU	Level-2-260C-1 YEAR	-40 to 85	OPA 4343EA	Samples
OPA4343NA/250	ACTIVE	TSSOP	PW	14	250	RoHS & Green	NIPDAU	Level-2-260C-1 YEAR	-40 to 85	OPA 4343NA	Samples
OPA4343NA/2K5	ACTIVE	TSSOP	PW	14	2500	RoHS & Green	NIPDAU	Level-2-260C-1 YEAR	-40 to 85	OPA 4343NA	Samples
OPA4343UA	ACTIVE	SOIC	D	14	50	RoHS & Green	NIPDAU	Level-2-260C-1 YEAR	-40 to 85	OPA4343UA	Samples
OPA4343UA/2K5	ACTIVE	SOIC	D	14	2500	RoHS & Green	NIPDAU	Level-1-260C-UNLIM	-40 to 85	OPA4343UA	Samples

(1) The marketing status values are defined as follows:

ACTIVE: Product device recommended for new designs.

LIFEBUY: TI has announced that the device will be discontinued, and a lifetime-buy period is in effect.

NRND: Not recommended for new designs. Device is in production to support existing customers, but TI does not recommend using this part in a new design.

PREVIEW: Device has been announced but is not in production. Samples may or may not be available.

OBSOLETE: TI has discontinued the production of the device.

(2) **RoHS:** TI defines "RoHS" to mean semiconductor products that are compliant with the current EU RoHS requirements for all 10 RoHS substances, including the requirement that RoHS substance do not exceed 0.1% by weight in homogeneous materials. Where designed to be soldered at high temperatures, "RoHS" products are suitable for use in specified lead-free processes. TI may reference these types of products as "Pb-Free".

RoHS Exempt: TI defines "RoHS Exempt" to mean products that contain lead but are compliant with EU RoHS pursuant to a specific EU RoHS exemption.

Green: TI defines "Green" to mean the content of Chlorine (Cl) and Bromine (Br) based flame retardants meet JS709B low halogen requirements of ≤ 1000 ppm threshold. Antimony trioxide based flame retardants must also meet the ≤ 1000 ppm threshold requirement.

(3) MSL, Peak Temp. - The Moisture Sensitivity Level rating according to the JEDEC industry standard classifications, and peak solder temperature.

(4) There may be additional marking, which relates to the logo, the lot trace code information, or the environmental category on the device.

(5) Multiple Device Markings will be inside parentheses. Only one Device Marking contained in parentheses and separated by a "~" will appear on a device. If a line is indented then it is a continuation of the previous line and the two combined represent the entire Device Marking for that device.

(6) Lead finish/Ball material - Orderable Devices may have multiple material finish options. Finish options are separated by a vertical ruled line. Lead finish/Ball material values may wrap to two lines if the finish value exceeds the maximum column width.

Important Information and Disclaimer: The information provided on this page represents TI's knowledge and belief as of the date that it is provided. TI bases its knowledge and belief on information provided by third parties, and makes no representation or warranty as to the accuracy of such information. Efforts are underway to better integrate information from third parties. TI has taken and continues to take reasonable steps to provide representative and accurate information but may not have conducted destructive testing or chemical analysis on incoming materials and chemicals. TI and TI suppliers consider certain information to be proprietary, and thus CAS numbers and other limited information may not be available for release.

In no event shall TI's liability arising out of such information exceed the total purchase price of the TI part(s) at issue in this document sold by TI to Customer on an annual basis.

TAPE AND REEL INFORMATION



QUADRANT ASSIGNMENTS FOR PIN 1 ORIENTATION IN TAPE

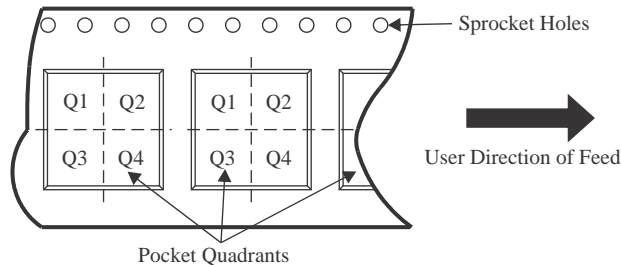

*All dimensions are nominal

Device	Package Type	Package Drawing	Pins	SPQ	Reel Diameter (mm)	Reel Width W1 (mm)	A0 (mm)	B0 (mm)	K0 (mm)	P1 (mm)	W (mm)	Pin1 Quadrant
OPA2343EA/250	VSSOP	DGK	8	250	330.0	12.4	5.3	3.4	1.4	8.0	12.0	Q1
OPA2343EA/2K5	VSSOP	DGK	8	2500	330.0	12.4	5.3	3.4	1.4	8.0	12.0	Q1
OPA2343UA/2K5	SOIC	D	8	2500	330.0	12.4	6.4	5.2	2.1	8.0	12.0	Q1
OPA343NA/250	SOT-23	DBV	5	250	178.0	9.0	3.23	3.17	1.37	4.0	8.0	Q3
OPA343NA/250	SOT-23	DBV	5	250	179.0	8.4	3.2	3.2	1.4	4.0	8.0	Q3
OPA343NA/3K	SOT-23	DBV	5	3000	179.0	8.4	3.2	3.2	1.4	4.0	8.0	Q3
OPA343NA/3K	SOT-23	DBV	5	3000	178.0	9.0	3.23	3.17	1.37	4.0	8.0	Q3
OPA343UA/2K5	SOIC	D	8	2500	330.0	12.4	6.4	5.2	2.1	8.0	12.0	Q1
OPA4343EA/250	SSOP	DBQ	16	250	180.0	12.4	6.4	5.2	2.1	8.0	12.0	Q1
OPA4343EA/2K5	SSOP	DBQ	16	2500	330.0	12.4	6.4	5.2	2.1	8.0	12.0	Q1
OPA4343NA/250	TSSOP	PW	14	250	180.0	12.4	6.9	5.6	1.6	8.0	12.0	Q1
OPA4343NA/2K5	TSSOP	PW	14	2500	330.0	12.4	6.9	5.6	1.6	8.0	12.0	Q1
OPA4343UA/2K5	SOIC	D	14	2500	330.0	16.4	6.5	9.0	2.1	8.0	16.0	Q1

TAPE AND REEL BOX DIMENSIONS

*All dimensions are nominal

Device	Package Type	Package Drawing	Pins	SPQ	Length (mm)	Width (mm)	Height (mm)
OPA2343EA/250	VSSOP	DGK	8	250	366.0	364.0	50.0
OPA2343EA/2K5	VSSOP	DGK	8	2500	366.0	364.0	50.0
OPA2343UA/2K5	SOIC	D	8	2500	356.0	356.0	35.0
OPA343NA/250	SOT-23	DBV	5	250	180.0	180.0	18.0
OPA343NA/250	SOT-23	DBV	5	250	203.0	203.0	35.0
OPA343NA/3K	SOT-23	DBV	5	3000	203.0	203.0	35.0
OPA343NA/3K	SOT-23	DBV	5	3000	180.0	180.0	18.0
OPA343UA/2K5	SOIC	D	8	2500	356.0	356.0	35.0
OPA4343EA/250	SSOP	DBQ	16	250	210.0	185.0	35.0
OPA4343EA/2K5	SSOP	DBQ	16	2500	356.0	356.0	35.0
OPA4343NA/250	TSSOP	PW	14	250	210.0	185.0	35.0
OPA4343NA/2K5	TSSOP	PW	14	2500	356.0	356.0	35.0
OPA4343UA/2K5	SOIC	D	14	2500	356.0	356.0	35.0

TUBE

*All dimensions are nominal

Device	Package Name	Package Type	Pins	SPQ	L (mm)	W (mm)	T (μm)	B (mm)
OPA2343UA	D	SOIC	8	75	506.6	8	3940	4.32
OPA343UA	D	SOIC	8	75	506.6	8	3940	4.32
OPA4343UA	D	SOIC	14	50	506.6	8	3940	4.32

IMPORTANT NOTICE AND DISCLAIMER

TI PROVIDES TECHNICAL AND RELIABILITY DATA (INCLUDING DATA SHEETS), DESIGN RESOURCES (INCLUDING REFERENCE DESIGNS), APPLICATION OR OTHER DESIGN ADVICE, WEB TOOLS, SAFETY INFORMATION, AND OTHER RESOURCES "AS IS" AND WITH ALL FAULTS, AND DISCLAIMS ALL WARRANTIES, EXPRESS AND IMPLIED, INCLUDING WITHOUT LIMITATION ANY IMPLIED WARRANTIES OF MERCHANTABILITY, FITNESS FOR A PARTICULAR PURPOSE OR NON-INFRINGEMENT OF THIRD PARTY INTELLECTUAL PROPERTY RIGHTS.

These resources are intended for skilled developers designing with TI products. You are solely responsible for (1) selecting the appropriate TI products for your application, (2) designing, validating and testing your application, and (3) ensuring your application meets applicable standards, and any other safety, security, regulatory or other requirements.

These resources are subject to change without notice. TI grants you permission to use these resources only for development of an application that uses the TI products described in the resource. Other reproduction and display of these resources is prohibited. No license is granted to any other TI intellectual property right or to any third party intellectual property right. TI disclaims responsibility for, and you will fully indemnify TI and its representatives against, any claims, damages, costs, losses, and liabilities arising out of your use of these resources.

TI's products are provided subject to [TI's Terms of Sale](#) or other applicable terms available either on [ti.com](https://www.ti.com) or provided in conjunction with such TI products. TI's provision of these resources does not expand or otherwise alter TI's applicable warranties or warranty disclaimers for TI products.

TI objects to and rejects any additional or different terms you may have proposed.

Mailing Address: Texas Instruments, Post Office Box 655303, Dallas, Texas 75265
Copyright © 2024, Texas Instruments Incorporated