

## REF1112 10ppm/°C, 1-μA, 1.25-V Shunt Voltage Reference

### 1 Features

- Small Package: SOT23-3
- Fixed Reverse Breakdown Voltage of 1.25 V
- Key Specifications
  - Output Voltage Tolerance:  $\pm 0.2\%$  (Maximum)
  - Low Output Noise (0.1 Hz to 10 Hz):  $25 \mu\text{V}_{\text{pp}}$  (Typical)
  - Temperature Range:  $-40^\circ\text{C}$  to  $+125^\circ\text{C}$
  - Operating Current Range:  $1.2 \mu\text{A}$  to  $5 \text{ mA}$
  - Low Temperature Coefficient From  $0^\circ\text{C}$  to  $+70^\circ\text{C}$ :  $30\text{ppm}/^\circ\text{C}$  (Maximum)
  - Low Temperature Coefficient From  $-40^\circ\text{C}$  to  $+85^\circ\text{C}$ :  $50\text{ppm}/^\circ\text{C}$  (Maximum)

### 2 Applications

- Battery-Powered Instruments
- Building Security Sensors
- Medical Equipment
- Field Transmitters
- Calibrators

### 3 Description

The REF1112 device is a two-terminal shunt reference designed for power- and space-sensitive applications. The REF1112 features an operating current of  $1 \mu\text{A}$  in a SOT23-3 package and is an improved, lower power solution for designs currently using voltage references in larger packages, such as the REF1004 and LT1004. The REF1112 is specified from  $-40^\circ\text{C}$  to  $+85^\circ\text{C}$  with operation extending from  $-40^\circ\text{C}$  to  $+125^\circ\text{C}$ .

The REF1112 complements other  $1\text{-}\mu\text{A}$  components from Texas Instruments including the OPA349 and TLV240x low-power operational amplifiers, and the TLV349x micropower voltage comparator.

Device Information<sup>(1)</sup>

PART NUMBER	PACKAGE	BODY SIZE (NOM)
REF1112	SOT-23 (3)	2.92 mm x 1.3 mm

(1) For all available packages, see the orderable addendum at the end of the data sheet.

#### Shunt Reference Application Schematic

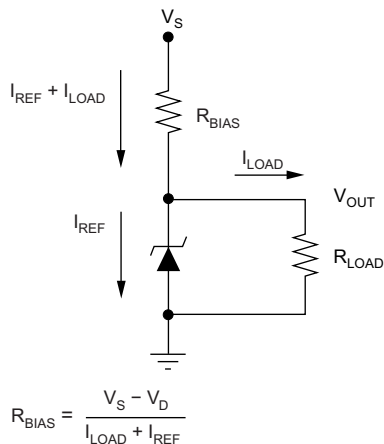

#### Pinout

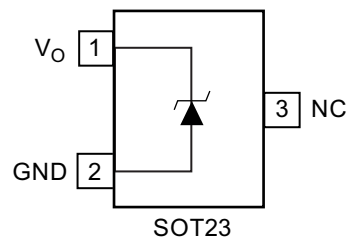

(1) NC indicates the pin should be left unconnected or connected to GND



## Table of Contents

<p><b>1 Features</b> ..... 1</p> <p><b>2 Applications</b> ..... 1</p> <p><b>3 Description</b> ..... 1</p> <p><b>4 Revision History</b>..... 2</p> <p><b>5 Pin Configuration and Functions</b> ..... 3</p> <p><b>6 Specifications</b>..... 3</p> <p>    6.1 Absolute Maximum Ratings ..... 3</p> <p>    6.2 ESD Ratings..... 3</p> <p>    6.3 Recommended Operating Conditions..... 3</p> <p>    6.4 Thermal Information ..... 4</p> <p>    6.5 Electrical Characteristics..... 4</p> <p>    6.6 Typical Characteristics ..... 5</p> <p><b>7 Detailed Description</b> ..... 7</p> <p>    7.1 Overview ..... 7</p> <p>    7.2 Functional Block Diagram ..... 7</p> <p>    7.3 Feature Description..... 7</p>	<p>    7.4 Device Functional Modes..... 7</p> <p><b>8 Application and Implementation</b> ..... 8</p> <p>    8.1 Application Information..... 8</p> <p>    8.2 Typical Applications ..... 8</p> <p><b>9 Power Supply Recommendations</b> ..... 12</p> <p><b>10 Layout</b>..... 12</p> <p>    10.1 Layout Guidelines ..... 12</p> <p>    10.2 Layout Example ..... 12</p> <p><b>11 Device and Documentation Support</b> ..... 13</p> <p>    11.1 Receiving Notification of Documentation Updates 13</p> <p>    11.2 Community Resources..... 13</p> <p>    11.3 Trademarks ..... 13</p> <p>    11.4 Electrostatic Discharge Caution..... 13</p> <p>    11.5 Glossary ..... 13</p> <p><b>12 Mechanical, Packaging, and Orderable Information</b> ..... 13</p>
--	--

## 4 Revision History

NOTE: Page numbers for previous revisions may differ from page numbers in the current version.

Changes from Revision C (March 2008) to Revision D	Page
<ul style="list-style-type: none"> <li>• Added <i>Device Information</i> table, <i>Pin Configuration and Functions</i> section, <i>Absolute Maximum Ratings</i> table, <i>ESD Ratings</i> table, <i>Recommended Operating Conditions</i> table, <i>Thermal Information</i> table, <i>Feature Description</i> section, <i>Device Functional Modes</i>, <i>Application and Implementation</i> section, <i>Power Supply Recommendations</i> section, <i>Layout</i> section, <i>Device and Documentation Support</i> section, and <i>Mechanical, Packaging, and Orderable Information</i> section. ....</li> </ul>	1
<ul style="list-style-type: none"> <li>• Changed <i>Features</i> section .....</li> </ul>	1
<ul style="list-style-type: none"> <li>• Changed key graphic text note from: NC indicates pin should be left unconnected to: NC indicates the pin should be left unconnected or connected to GND .....</li> </ul>	1
<ul style="list-style-type: none"> <li>• Removed the <i>Package/Ordering Information</i> table and moved the information over to the <i>Mechanical, Packaging, and Orderable Information</i> section .....</li> </ul>	13

## 5 Pin Configuration and Functions

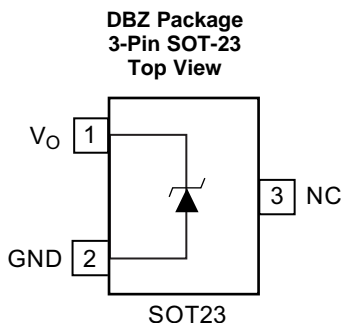

### Pin Functions

PIN		I/O	DESCRIPTION
NAME	NO.		
V <sub>O</sub>	1	I/O	Shunt Current/Voltage input
GND	2	O	Ground connection
NC	3	-	Must float or connect to GND

## 6 Specifications

### 6.1 Absolute Maximum Ratings

over operating free-air temperature range (unless otherwise noted)<sup>(1)</sup>

	MIN	MAX	UNIT
Reverse breakdown current		10	mA
Forward current		10	mA
Operating temperature	-55	125	°C
Junction temperature		150	°C
Storage temperature, T <sub>stg</sub>	-65	150	°C

- (1) Stresses beyond those listed under *Absolute Maximum Ratings* may cause permanent damage to the device. These are stress ratings only, which do not imply functional operation of the device at these or any other conditions beyond those indicated under *Recommended Operating Conditions*. Exposure to absolute-maximum-rated conditions for extended periods may affect device reliability.

### 6.2 ESD Ratings

		VALUE	UNIT
V <sub>(ESD)</sub>	Electrostatic discharge	Human-body model (HBM), per ANSI/ESDA/JEDEC JS-001 <sup>(1)</sup>	±2000
		Charged-device model (CDM), per JEDEC specification JESD22-C101 <sup>(2)</sup>	±1000

- (1) JEDEC document JEP155 states that 500-V HBM allows safe manufacturing with a standard ESD control process.

- (2) JEDEC document JEP157 states that 250-V CDM allows safe manufacturing with a standard ESD control process.

### 6.3 Recommended Operating Conditions

over operating free-air temperature range (unless otherwise noted)

	MIN	MAX	UNIT
I <sub>REF</sub>	Reverse current	0.0012	5
T <sub>A</sub>	Operating temperature	-40	125

## 6.4 Thermal Information

THERMAL METRIC <sup>(1)</sup>		REF1112	
		DBZ (SOT-23)	UNIT
		3 PINS	
$R_{\theta JA}$	Junction-to-ambient thermal resistance	219	°C/W
$R_{\theta JC(top)}$	Junction-to-case (top) thermal resistance	99	°C/W
$R_{\theta JB}$	Junction-to-board thermal resistance	79	°C/W
$\psi_{JT}$	Junction-to-top characterization parameter	6.7	°C/W
$\psi_{JB}$	Junction-to-board characterization parameter	79.6	°C/W

(1) For more information about traditional and new thermal metrics, see the [Semiconductor and IC Package Thermal Metrics](#) application report.

## 6.5 Electrical Characteristics

$V_R = 1.25\text{ V}$ ,  $T_A = +25^\circ\text{C}$ ,  $I_{REF} = 1.2\ \mu\text{A}$  and  $C_{LOAD} = 10\ \text{nF}$ , unless otherwise noted.

PARAMETER		TEST CONDITIONS	MIN	TYP	MAX	UNIT
$V_R$	Reverse breakdown voltage	$I_{REF} = 1.2\ \mu\text{A}$	1.2475	1.25	1.2525	V
			–0.2%		0.2%	
$\Delta V_R$	Temperature coefficient	$1.2\ \mu\text{A} \leq I_{REF} \leq 5\ \text{mA}$ , $T_A = 0^\circ\text{C}$ to $+70^\circ\text{C}$		10	30	ppm/°C
		$1.5\ \mu\text{A} \leq I_{REF} \leq 5\ \text{mA}$ , $T_A = -40^\circ\text{C}$ to $+85^\circ\text{C}$		15	50	
		$1.5\ \mu\text{A} \leq I_{REF} \leq 5\ \text{mA}$ , $T_A = -40^\circ\text{C}$ to $+125^\circ\text{C}$		15		
$I_{RMIN}$	Minimum operating current			1	1.2	$\mu\text{A}$
$\Delta V_R/\Delta I_R$	Reverse breakdown voltage change with current	$1.2\ \mu\text{A} \leq I_{REF} \leq 5\ \text{mA}$		30	100	ppm/mA
$Z_R$	Reverse dynamic impedance	$1.2\ \mu\text{A} \leq I_{REF} \leq 5\ \text{mA}$		0.037	0.125	$\Omega$
$e_N$	Low-frequency noise <sup>(1)</sup>	$0.1\ \text{Hz} \leq I_{REF} \leq 10\ \text{Hz}$		25		$\mu\text{V}_{PP}$
$V_{HYST}$	Thermal hysteresis <sup>(2)</sup>			100		ppm
$\Delta V_R$	Long-term stability	$+25^\circ\text{C} \pm 0.1^\circ\text{C}$		60		ppm/kHr

(1) Peak-to-peak noise is measured with a 2-pole high-pass filter at 0.1 Hz and a 4-pole, low-pass Chebyshev filter at 10 Hz.

(2) Thermal hysteresis is defined as the change in output voltage after operating the device at  $+25^\circ\text{C}$ , cycling the device through the specified temperature range, and returning to  $+25^\circ\text{C}$ .

## 6.6 Typical Characteristics

At  $T_A = +25^\circ\text{C}$ ,  $I_{\text{REF}} = 10 \mu\text{A}$  and  $C_{\text{LOAD}} = 10 \text{ nF}$ , unless otherwise noted.

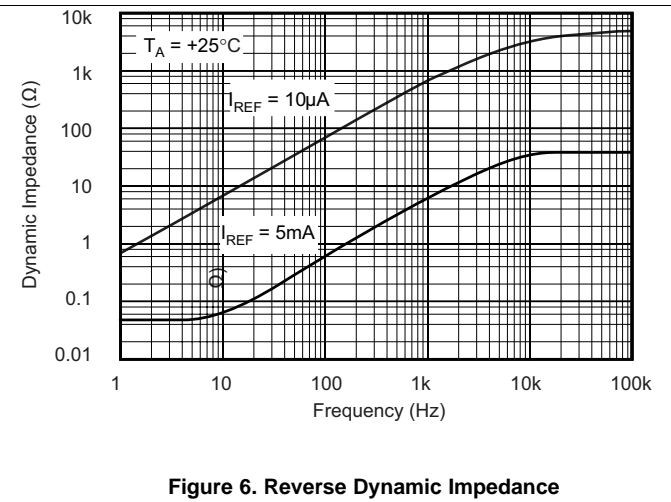
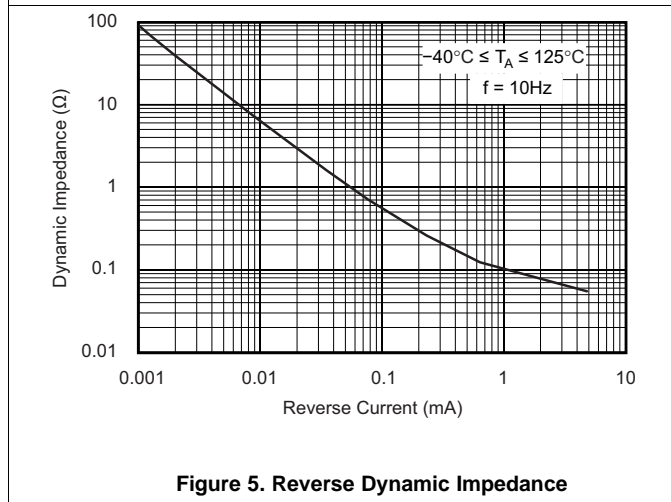
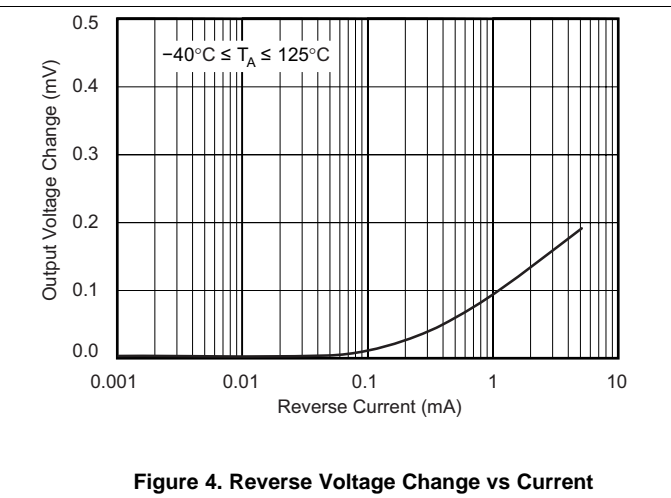
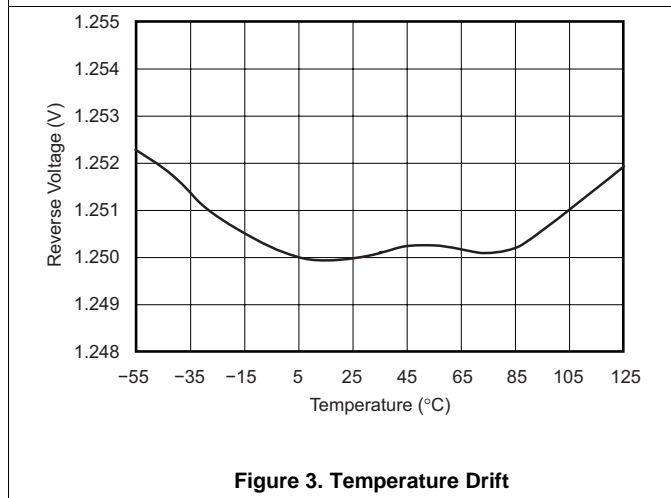
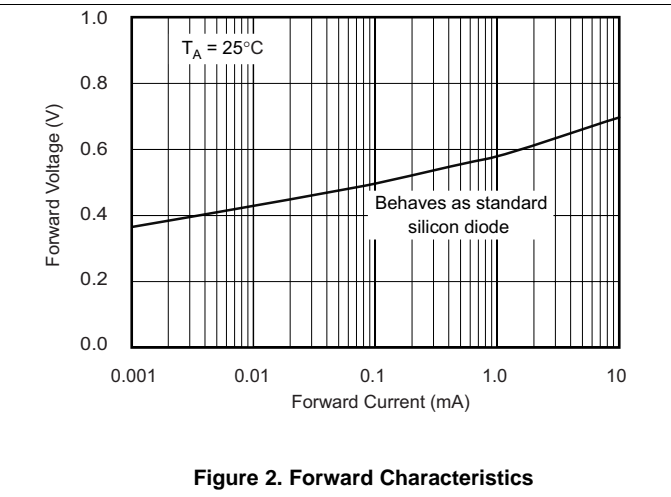
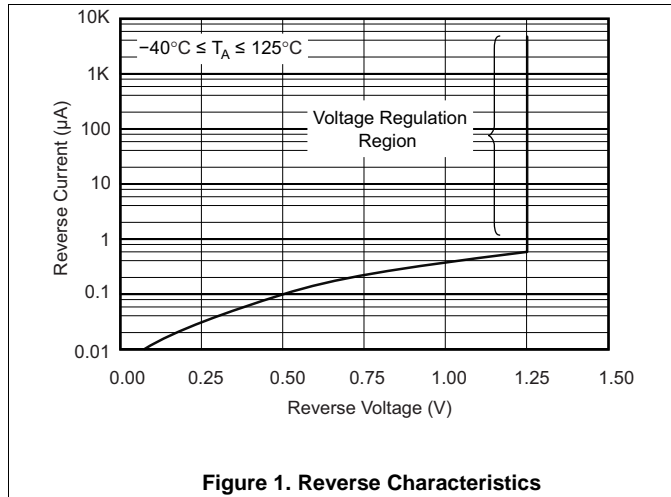

### Typical Characteristics (continued)

At  $T_A = +25^\circ\text{C}$ ,  $I_{REF} = 10\ \mu\text{A}$  and  $C_{LOAD} = 10\ \text{nF}$ , unless otherwise noted.

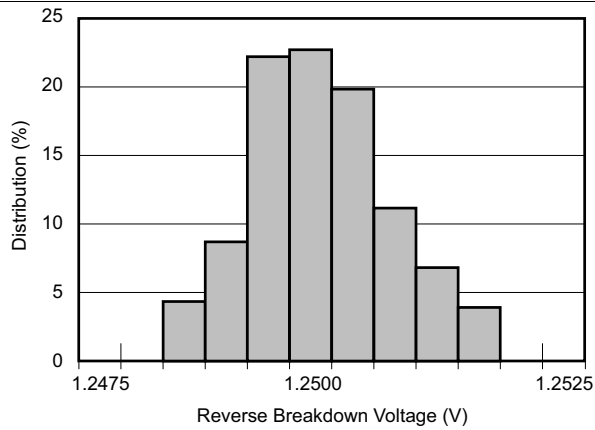

Figure 7. Reverse Breakdown Voltage Distribution

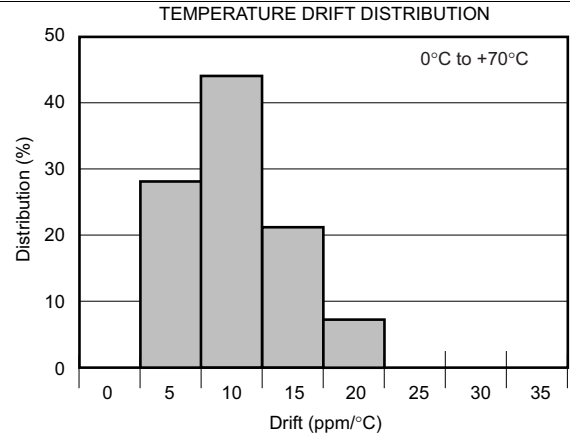

Figure 8. Temperature Drift Distribution

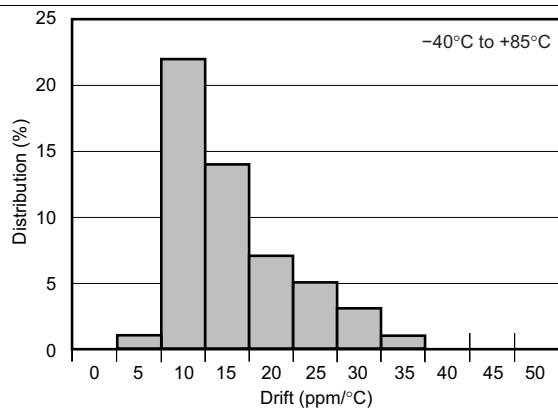

Figure 9. Temperature Drift Distribution

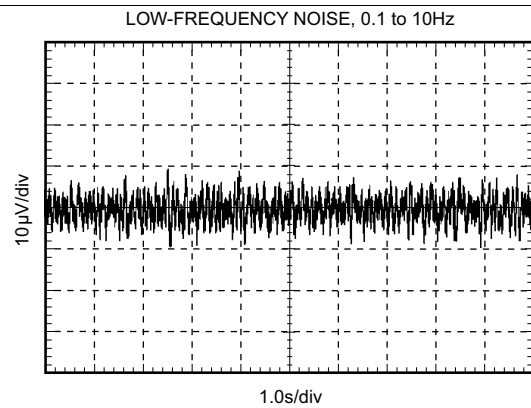

Figure 10. Low-Frequency Noise, 0.1 to 10Hz

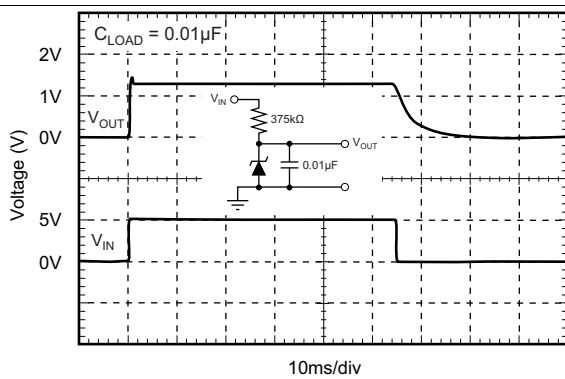

Figure 11. Response Time

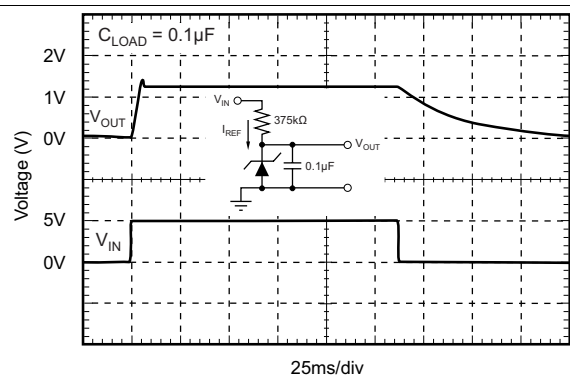

Figure 12. Response Time

## 7 Detailed Description

### 7.1 Overview

The REF1112 is a 2-terminal bandgap reference diode designed for high accuracy with outstanding temperature characteristics at low operating currents. Precision thin-film resistors result in 0.2% initial voltage accuracy and 50ppm/°C maximum temperature drift. The REF1112 is specified from –40°C to +85°C, with operation from –40°C to +125°C, and is offered in a SOT23-3 package.

### 7.2 Functional Block Diagram

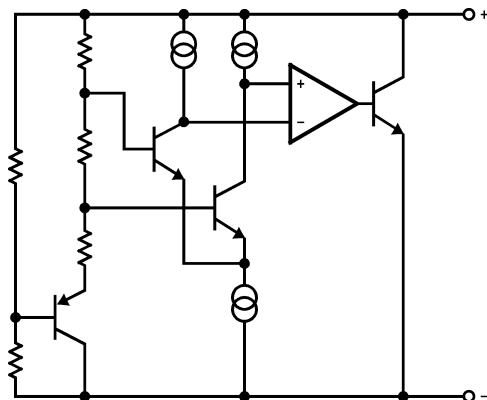

### 7.3 Feature Description

The REF1112 device is effectively a precision Zener diode. The part requires a small quiescent current for regulation, and regulates the output voltage by shunting more or less current to ground, depending on input voltage and load. The only external component requirements are a resistor between the cathode and the input voltage to set the input current and an external capacitor at the output to maintain stability under varying loads.

### 7.4 Device Functional Modes

The REF1112 device is a fixed output voltage part where the feedback is internal. Therefore, the part can only operate in a closed-loop mode and the output voltage cannot be adjusted. The output voltage will remain in regulation as long as  $I_{REF}$  is between  $I_{REFMIN}$  (see [Electrical Characteristics](#)) and  $I_{REFMAX}$  is 5 mA. A proper selection of the external resistor for input voltage range and load current range will ensure these conditions are met.

## 8 Application and Implementation

### NOTE

Information in the following applications sections is not part of the TI component specification, and TI does not warrant its accuracy or completeness. TI's customers are responsible for determining suitability of components for their purposes. Customers should validate and test their design implementation to confirm system functionality.

### 8.1 Application Information

Typical connections for the REF1112 are shown in [Figure 13](#). A minimum 1- $\mu$ A bias current is required to maintain a stable output voltage and can be provided with a resistor connected to the supply voltage.  $I_{BIAS}$  depends on the values selected for  $R_{BIAS}$  and  $V_S$ , and will vary as a sum of the minimum operating current and the load current. To maintain stable operation, the value of  $R_{BIAS}$  must be low enough to maintain the minimum operating current at the minimum and maximum load and supply voltage levels.

A 0.1- $\mu$ F load capacitor is recommended to maintain stability under varying load conditions. A minimum 0.01- $\mu$ F load capacitor is required for stable operation. Start-up time for the REF1112 will be affected, depending on the value of load capacitance and the bias currents being used. A 1- $\mu$ F power-supply bypass capacitor is recommended to minimize supply noise within the circuit. The REF1112 shunt voltage reference provides a versatile function for low power and space-conservative applications.

### 8.2 Typical Applications

#### 8.2.1 Shunt Regulator

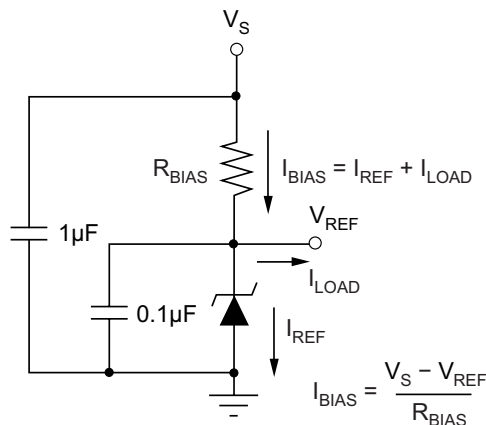

Figure 13. Typical Connections

#### 8.2.1.1 Design Requirements

Table 1. Design Parameters

DESIGN PARAMETER	EXAMPLE VALUE
Supply voltage	3 V
Cathode current ( $I_{REF}$ )	1.2 $\mu$ A
Load Current ( $I_{LOAD}$ )	50 $\mu$ A



### 8.2.1.2 Detailed Design Procedure

When using the REF1112 as a reference, determine the following:

- Supply voltage range
- Current source resistance
- Reference voltage accuracy

To design using the REF1112, is it important to ensure that the  $V_S$  is larger than  $V_{REF}$ .

The resistor  $R_{BIAS}$  sets the cathode current of the REF1112,  $I_R$ . Ensure that this current remains in the operational region of the part for the entire  $V_S$  and load range.

Using this information, select a  $R_{BIAS}$  such that:

$$I_{REFMIN} < I_{REF} < I_{REFMAX} \text{ where } I_{REFMAX} = 5 \text{ mA.}$$

In this application the  $I_{REF}$  is the operating current of the REF1112 plus the maximum possible  $I_{LOAD}$  under no-load conditions.

### 8.2.2 MicroPOWER 3- $\mu$ A, 1-V Voltage Reference

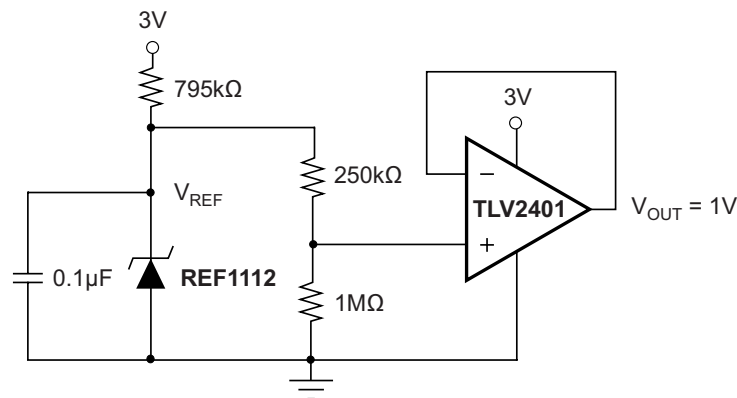

Copyright © 2018, Texas Instruments Incorporated

**Figure 14. MicroPOWER 3- $\mu$ A, 1-V Voltage Reference**

#### 8.2.2.1 Design Requirements

The REF1112 can be scaled to provide extremely low power reference voltages. [Figure 14](#) shows the REF1112 used as a 1-V  $V_{OUT}$ , 3- $\mu$ A voltage reference.

#### 8.2.2.2 Detailed Design Procedure

Set  $R_{BIAS}$  such that the current through the shunt reference,  $I_{REF}$ , is greater than  $I_{REFMIN} + I_{LOAD}$ .

Use a resistor divider to set the required voltage to the input of the amplifier. The TLV2401 requires an input bias current maximum of 350 pA which allows the use of larger resistor values to save power.

### 8.2.3 2.5-V Reference on 1 $\mu\text{A}$

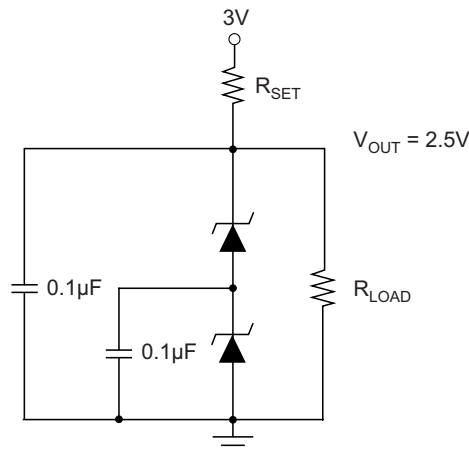

Figure 15. 2.5-V Reference on 1  $\mu\text{A}$

#### 8.2.3.1 Design Requirements

Create a 2.5-V reference that consumes 1  $\mu\text{A}$  of  $I_{\text{REF}}$ .

#### 8.2.3.2 Detailed Design Procedure

Figure 15 shows the REF1112 used as a 2.5-V reference on 1  $\mu\text{A}$ . This is done by stacking the REF1112 in series.

$$V_{\text{OUT}} = 2 \times V_{\text{REF}}$$

where

- $V_{\text{REF}}$  is the reference voltage (1)

In this case,  $V_{\text{OUT}} = 2 \times 1.25 \text{ V} = 2.5 \text{ V}$

The  $I_{\text{BIAS}}$  is still 1  $\mu\text{A}$  because the stacked REF1112 are in series.

#### 8.2.4 Adjustable Voltage Shunt Reference

For applications requiring a stable voltage reference capable of sinking higher than 5 mA of current, a REF1112 combined with an OPA347 can sink up to 10 mA of current. This configuration is shown in Figure 16, and through appropriate selection of  $R_1$  and  $R_2$ , can be used to provide a wide range of stable reference voltages.

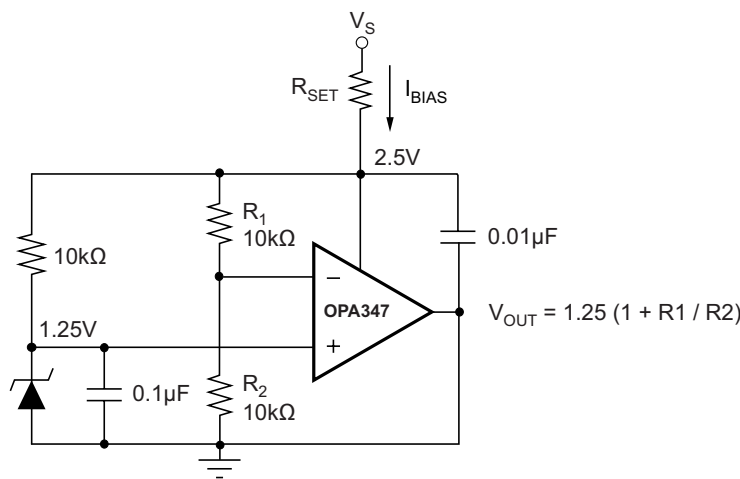

Copyright © 2018, Texas Instruments Incorporated

Figure 16. Adjustable Voltage Shunt Reference

### 8.2.5 Level Shift to Achieve Full ADC Input Range

The REF1112 is also useful for level shifting, and as shown in Figure 17, can be used to achieve the full input range of an analog-to-digital converter (ADC).

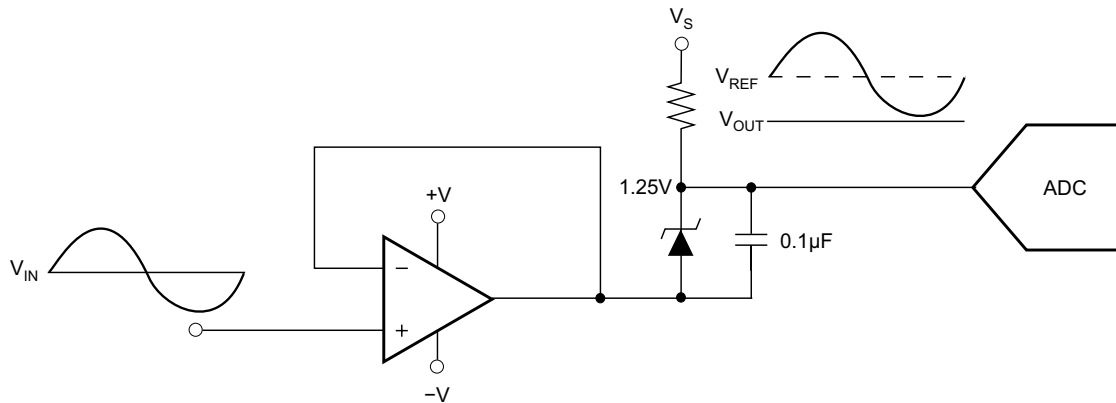

Figure 17. REF1112 Provides a Level Shift to Achieve Full ADC Input Range

### 8.2.6 Stable Current Source

The REF1112 can be configured with an additional diode and NPN transistor to provide a temperature compensated current reference as shown in Figure 18.

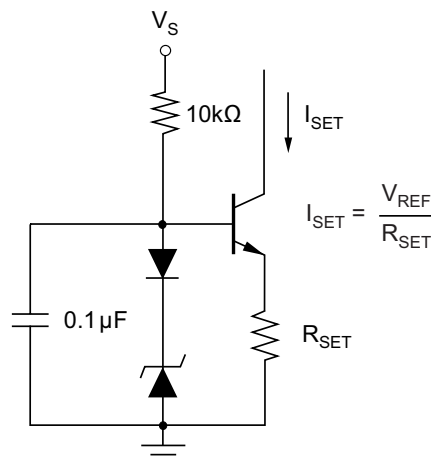

Figure 18. REF1112 as a Stable Current Source

## 9 Power Supply Recommendations

While a bypass capacitor is not required on the input voltage line, TI recommends reducing noise on the input which could affect the output. A 0.1- $\mu$ F ceramic capacitor or larger is recommended.

## 10 Layout

### 10.1 Layout Guidelines

Place decoupling capacitors as close to the device as possible. Use appropriate widths for traces when shunting high currents to avoid excessive voltage drops.

### 10.2 Layout Example

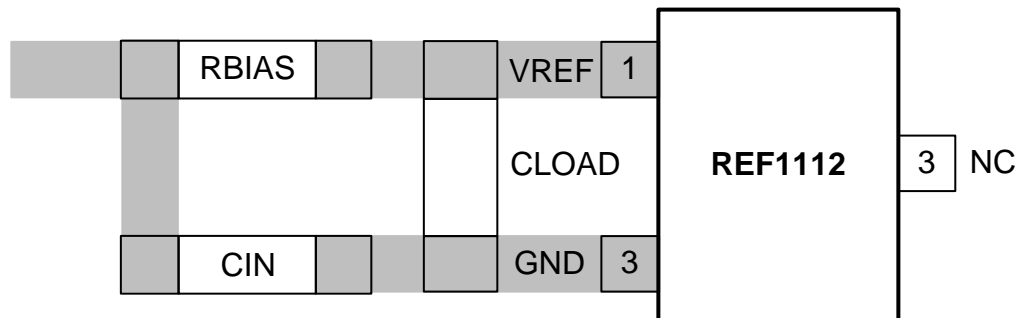

**Figure 19. Layout Example**

## 11 Device and Documentation Support

### 11.1 Receiving Notification of Documentation Updates

To receive notification of documentation updates, navigate to the device product folder on ti.com. In the upper right corner, click on *Alert me* to register and receive a weekly digest of any product information that has changed. For change details, review the revision history included in any revised document.

### 11.2 Community Resources

The following links connect to TI community resources. Linked contents are provided "AS IS" by the respective contributors. They do not constitute TI specifications and do not necessarily reflect TI's views; see TI's [Terms of Use](#).

**TI E2E™ Online Community** *TI's Engineer-to-Engineer (E2E) Community*. Created to foster collaboration among engineers. At e2e.ti.com, you can ask questions, share knowledge, explore ideas and help solve problems with fellow engineers.

**Design Support** *TI's Design Support* Quickly find helpful E2E forums along with design support tools and contact information for technical support.

### 11.3 Trademarks

E2E is a trademark of Texas Instruments.  
All other trademarks are the property of their respective owners.

### 11.4 Electrostatic Discharge Caution



This integrated circuit can be damaged by ESD. Texas Instruments recommends that all integrated circuits be handled with appropriate precautions. Failure to observe proper handling and installation procedures can cause damage.

ESD damage can range from subtle performance degradation to complete device failure. Precision integrated circuits may be more susceptible to damage because very small parametric changes could cause the device not to meet its published specifications.

### 11.5 Glossary

[SLYZ022](#) — *TI Glossary*.

This glossary lists and explains terms, acronyms, and definitions.

## 12 Mechanical, Packaging, and Orderable Information

The following pages include mechanical, packaging, and orderable information. This information is the most current data available for the designated devices. This data is subject to change without notice and revision of this document. For browser-based versions of this data sheet, refer to the left-hand navigation.

**PACKAGING INFORMATION**

Orderable Device	Status (1)	Package Type	Package Drawing	Pins	Package Qty	Eco Plan (2)	Lead finish/ Ball material (6)	MSL Peak Temp (3)	Op Temp (°C)	Device Marking (4/5)	Samples
REF1112AIDBZR	ACTIVE	SOT-23	DBZ	3	3000	RoHS & Green	NIPDAU	Level-1-260C-UNLIM	-40 to 125	R11A	<a href="#">Samples</a>
REF1112AIDBZT	ACTIVE	SOT-23	DBZ	3	250	RoHS & Green	NIPDAU	Level-1-260C-UNLIM	-40 to 125	R11A	<a href="#">Samples</a>

(1) The marketing status values are defined as follows:

**ACTIVE:** Product device recommended for new designs.

**LIFEBUY:** TI has announced that the device will be discontinued, and a lifetime-buy period is in effect.

**NRND:** Not recommended for new designs. Device is in production to support existing customers, but TI does not recommend using this part in a new design.

**PREVIEW:** Device has been announced but is not in production. Samples may or may not be available.

**OBSOLETE:** TI has discontinued the production of the device.

(2) **RoHS:** TI defines "RoHS" to mean semiconductor products that are compliant with the current EU RoHS requirements for all 10 RoHS substances, including the requirement that RoHS substance do not exceed 0.1% by weight in homogeneous materials. Where designed to be soldered at high temperatures, "RoHS" products are suitable for use in specified lead-free processes. TI may reference these types of products as "Pb-Free".

**RoHS Exempt:** TI defines "RoHS Exempt" to mean products that contain lead but are compliant with EU RoHS pursuant to a specific EU RoHS exemption.

**Green:** TI defines "Green" to mean the content of Chlorine (Cl) and Bromine (Br) based flame retardants meet JS709B low halogen requirements of <=1000ppm threshold. Antimony trioxide based flame retardants must also meet the <=1000ppm threshold requirement.

(3) MSL, Peak Temp. - The Moisture Sensitivity Level rating according to the JEDEC industry standard classifications, and peak solder temperature.

(4) There may be additional marking, which relates to the logo, the lot trace code information, or the environmental category on the device.

(5) Multiple Device Markings will be inside parentheses. Only one Device Marking contained in parentheses and separated by a "~" will appear on a device. If a line is indented then it is a continuation of the previous line and the two combined represent the entire Device Marking for that device.

(6) Lead finish/Ball material - Orderable Devices may have multiple material finish options. Finish options are separated by a vertical ruled line. Lead finish/Ball material values may wrap to two lines if the finish value exceeds the maximum column width.

**Important Information and Disclaimer:**The information provided on this page represents TI's knowledge and belief as of the date that it is provided. TI bases its knowledge and belief on information provided by third parties, and makes no representation or warranty as to the accuracy of such information. Efforts are underway to better integrate information from third parties. TI has taken and continues to take reasonable steps to provide representative and accurate information but may not have conducted destructive testing or chemical analysis on incoming materials and chemicals. TI and TI suppliers consider certain information to be proprietary, and thus CAS numbers and other limited information may not be available for release.

In no event shall TI's liability arising out of such information exceed the total purchase price of the TI part(s) at issue in this document sold by TI to Customer on an annual basis.



**TAPE AND REEL INFORMATION**

**QUADRANT ASSIGNMENTS FOR PIN 1 ORIENTATION IN TAPE**

\*All dimensions are nominal

Device	Package Type	Package Drawing	Pins	SPQ	Reel Diameter (mm)	Reel Width W1 (mm)	A0 (mm)	B0 (mm)	K0 (mm)	P1 (mm)	W (mm)	Pin1 Quadrant
REF1112AIDBZR	SOT-23	DBZ	3	3000	179.0	8.4	3.15	2.95	1.22	4.0	8.0	Q3
REF1112AIDBZT	SOT-23	DBZ	3	250	179.0	8.4	3.15	2.95	1.22	4.0	8.0	Q3



**TAPE AND REEL BOX DIMENSIONS**

\*All dimensions are nominal

Device	Package Type	Package Drawing	Pins	SPQ	Length (mm)	Width (mm)	Height (mm)
REF1112AIDBZR	SOT-23	DBZ	3	3000	200.0	183.0	25.0
REF1112AIDBZT	SOT-23	DBZ	3	250	200.0	183.0	25.0

# DBZ0003A



# PACKAGE OUTLINE

SOT-23 - 1.12 mm max height

SMALL OUTLINE TRANSISTOR

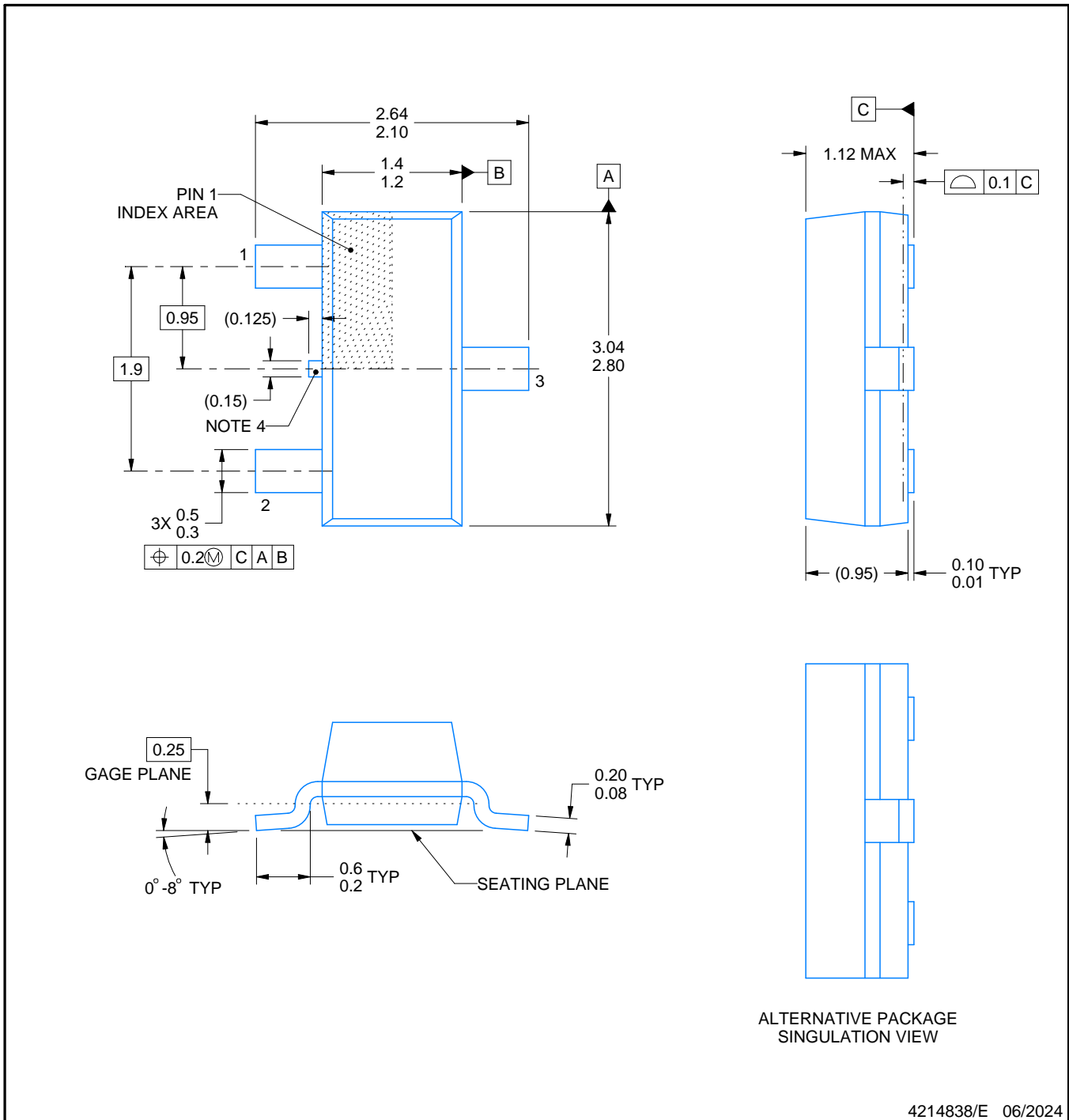

4214838/E 06/2024

## NOTES:

- All linear dimensions are in millimeters. Any dimensions in parenthesis are for reference only. Dimensioning and tolerancing per ASME Y14.5M.
- This drawing is subject to change without notice.
- Reference JEDEC registration TO-236, except minimum foot length.
- Support pin may differ or may not be present.
- Body dimensions do not include mold flash, protrusions, or gate burrs. Mold flash, protrusions, or gate burrs shall not exceed 0.25mm per side

# EXAMPLE BOARD LAYOUT

DBZ0003A

SOT-23 - 1.12 mm max height

SMALL OUTLINE TRANSISTOR

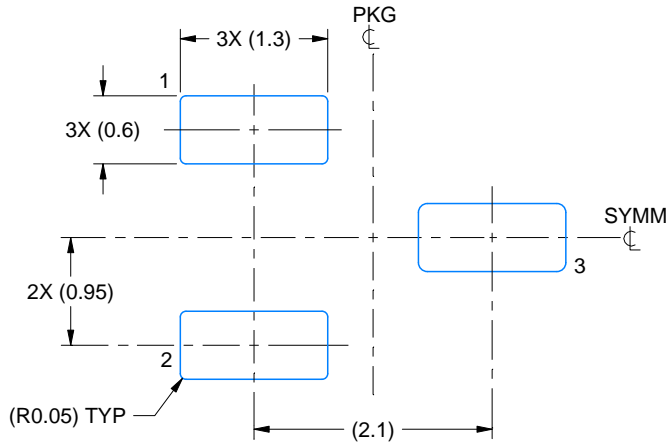

LAND PATTERN EXAMPLE  
SCALE:15X

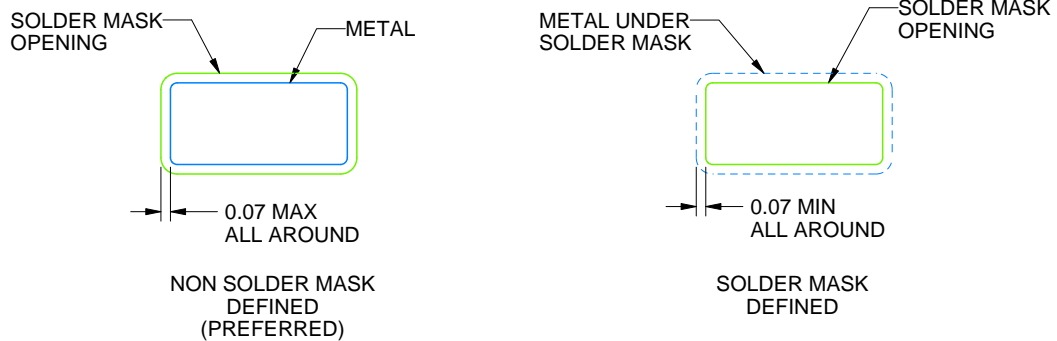

SOLDER MASK DETAILS

4214838/E 06/2024

NOTES: (continued)

5. Publication IPC-7351 may have alternate designs.
6. Solder mask tolerances between and around signal pads can vary based on board fabrication site.

# EXAMPLE STENCIL DESIGN

DBZ0003A

SOT-23 - 1.12 mm max height

SMALL OUTLINE TRANSISTOR

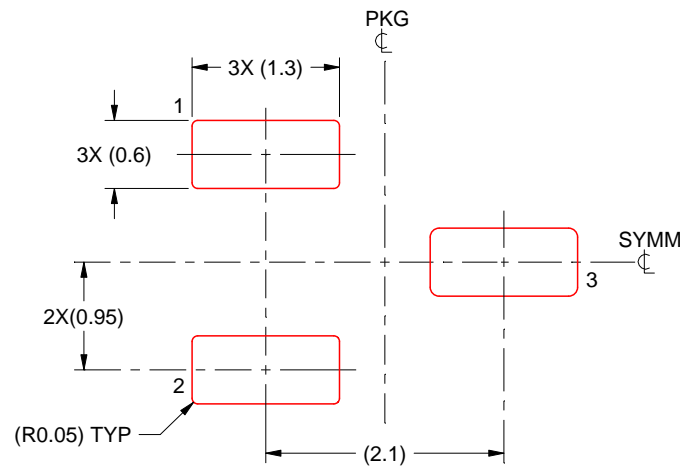

SOLDER PASTE EXAMPLE  
BASED ON 0.125 THICK STENCIL  
SCALE:15X

4214838/E 06/2024

NOTES: (continued)

7. Laser cutting apertures with trapezoidal walls and rounded corners may offer better paste release. IPC-7525 may have alternate design recommendations.
8. Board assembly site may have different recommendations for stencil design.

## IMPORTANT NOTICE AND DISCLAIMER

TI PROVIDES TECHNICAL AND RELIABILITY DATA (INCLUDING DATA SHEETS), DESIGN RESOURCES (INCLUDING REFERENCE DESIGNS), APPLICATION OR OTHER DESIGN ADVICE, WEB TOOLS, SAFETY INFORMATION, AND OTHER RESOURCES "AS IS" AND WITH ALL FAULTS, AND DISCLAIMS ALL WARRANTIES, EXPRESS AND IMPLIED, INCLUDING WITHOUT LIMITATION ANY IMPLIED WARRANTIES OF MERCHANTABILITY, FITNESS FOR A PARTICULAR PURPOSE OR NON-INFRINGEMENT OF THIRD PARTY INTELLECTUAL PROPERTY RIGHTS.

These resources are intended for skilled developers designing with TI products. You are solely responsible for (1) selecting the appropriate TI products for your application, (2) designing, validating and testing your application, and (3) ensuring your application meets applicable standards, and any other safety, security, regulatory or other requirements.

These resources are subject to change without notice. TI grants you permission to use these resources only for development of an application that uses the TI products described in the resource. Other reproduction and display of these resources is prohibited. No license is granted to any other TI intellectual property right or to any third party intellectual property right. TI disclaims responsibility for, and you will fully indemnify TI and its representatives against, any claims, damages, costs, losses, and liabilities arising out of your use of these resources.

TI's products are provided subject to [TI's Terms of Sale](#) or other applicable terms available either on [ti.com](https://www.ti.com) or provided in conjunction with such TI products. TI's provision of these resources does not expand or otherwise alter TI's applicable warranties or warranty disclaimers for TI products.

TI objects to and rejects any additional or different terms you may have proposed.

Mailing Address: Texas Instruments, Post Office Box 655303, Dallas, Texas 75265  
Copyright © 2024, Texas Instruments Incorporated