

# SN54LS181, SN54S181 SN74LS181, SN74S181 ARITHMETIC LOGIC UNITS/FUNCTION GENERATORS

SDLS136 - DECEMBER 1972 - REVISED MARCH 1988

- Full Look-Ahead for High-Speed Operations on Long Words
- Input Clamping Diodes Minimize Transmission-Line Effects
- Darlington Outputs Reduce Turn-Off Time
- Arithmetic Operating Modes:
  - Addition
  - Subtraction
  - Shift Operand A One Position
  - Magnitude Comparison
  - Plus Twelve Other Arithmetic Operations
- Logic Function Modes:
  - Exclusive-OR
  - Comparator
  - AND, NAND, OR, NOR
  - Plus Ten Other Logic Operations

SN54LS181, SN54S181 . . . J OR W PACKAGE  
SN74LS181, SN74S181 . . . DW OR N PACKAGE

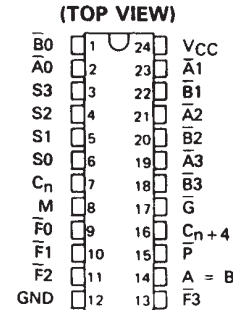

SN54LS181, SN54S181 . . . FK PACKAGE

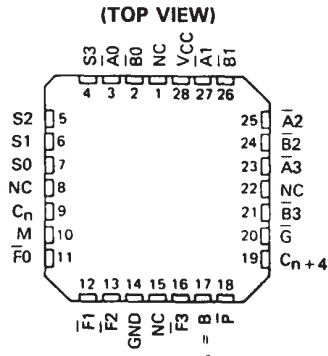

NC - No internal connection

TYPICAL ADDITION TIMES

NUMBER OF BITS	ADDITION TIMES		PACKAGE COUNT		CARRY METHOD BETWEEN ALUs
	USING 'LS181 AND 'S182	USING 'S181 AND 'S182	ARITHMETIC/ LOGIC UNITS	LOOK-AHEAD CARRY GENERATORS	
1 to 4	24 ns	11 ns	1		NONE
5 to 8	40 ns	18 ns	2		RIPPLE
9 to 16	44 ns	19 ns	3 or 4	1	FULL LOOK-AHEAD
17 to 64	68 ns	28 ns	5 to 16	2 to 5	FULL LOOK-AHEAD

## description

The 'LS181 and 'S181 are arithmetic logic units (ALU)/function generators that have a complexity of 75 equivalent gates on a monolithic chip. These circuits perform 16 binary arithmetic operations on two 4-bit words as shown in Tables 1 and 2. These operations are selected by the four function-select lines (S0, S1, S2, S3) and include addition, subtraction, decrement, and straight transfer. When performing arithmetic manipulations, the internal carries must be enabled by applying a low-level voltage to the mode control input (M). A full carry look-ahead scheme is made available in these devices for fast, simultaneous carry generation by means of two cascade-outputs (pins 15 and 17) for the four bits in the package. When used in conjunction with the SN54S182 or SN74S182 full carry look-ahead circuits, high-speed arithmetic operations can be performed. The typical addition times shown above illustrate the little additional time required for addition of longer words when full carry look-ahead is employed. The method of cascading 'S182 circuits with these ALUs to provide multi-level full carry look-ahead is illustrated under typical applications data for the 'S182.

If high speed is not of importance, a ripple-carry input ( $C_n$ ) and a ripple-carry output ( $C_n + 4$ ) are available. However, the ripple-carry delay has also been minimized so that arithmetic manipulations for small word lengths can be performed without external circuitry.

PRODUCTION DATA information is current as of publication date. Products conform to specifications per the terms of Texas Instruments standard warranty. Production processing does not necessarily include testing of all parameters.



**SN54LS181, SN54S181  
SN74LS181, SN74S181  
ARITHMETIC LOGIC UNITS/FUNCTION GENERATORS**

SDLS136 – DECEMBER 1972 – REVISED MARCH 1988

**description (continued)**

The 'LS181 and 'S181 will accommodate active-high data if the pin designations are interpreted as follows:

PIN NUMBER	2	1	23	22	21	20	19	18	9	10	11	13	7	16	15	17
Active-low data (Table 1)	$\bar{A}_0$	$\bar{B}_0$	$\bar{A}_1$	$\bar{B}_1$	$\bar{A}_2$	$\bar{B}_2$	$\bar{A}_3$	$\bar{B}_3$	$\bar{F}_0$	$\bar{F}_1$	$\bar{F}_2$	$\bar{F}_3$	$C_n$	$C_{n+4}$	$\bar{P}$	$\bar{G}$
Active-high data (Table 2)	A <sub>0</sub>	B <sub>0</sub>	A <sub>1</sub>	B <sub>1</sub>	A <sub>2</sub>	B <sub>2</sub>	A <sub>3</sub>	B <sub>3</sub>	F <sub>0</sub>	F <sub>1</sub>	F <sub>2</sub>	F <sub>3</sub>	$\bar{C}_n$	$\bar{C}_{n+4}$	X	Y

Subtraction is accomplished by 1's complement addition where the 1's complement of the subtrahend is generated internally. The resultant output is  $A-B-1$ , which requires an end-around or forced carry to provide  $A-B$ .

The 'LS181 or 'S181 can also be utilized as a comparator. The  $A = B$  output is internally decoded from the function outputs ( $F_0, F_1, F_2, F_3$ ) so that when two words of equal magnitude are applied at the A and B inputs, it will assume a high level to indicate equality ( $A=B$ ). The ALU must be in the subtract mode with  $C_n = H$  when performing this comparison. The  $A = B$  output is open-collector so that it can be wire-AND connected to give a comparison for more than four bits. The carry output ( $C_{n+4}$ ) can also be used to supply relative magnitude information. Again, the ALU must be placed in the subtract mode by placing the function select inputs  $S_3, S_2, S_1, S_0$  at L, H, H, L, respectively.

INPUT $C_n$	OUTPUT $C_{n+4}$	ACTIVE-LOW DATA (FIGURE 1)	ACTIVE-HIGH DATA (FIGURE 2)
H	H	$A > B$	$A < B$
H	L	$A < B$	$A > B$
L	H	$A > B$	$A < B$
L	L	$A < B$	$A > B$

These circuits have been designed to not only incorporate all of the designer's requirements for arithmetic operations, but also to provide 16 possible functions of two Boolean variables without the use of external circuitry. These logic functions are selected by use of the four function-select inputs ( $S_0, S_1, S_2, S_3$ ) with the mode-control input (M) at a high level to disable the internal carry. The 16 logic functions are detailed in Tables 1 and 2 and include exclusive-OR, NAND, AND, NOR, and OR functions.

Series 54, 54LS, and 54S devices are characterized for operation over the full military temperature range of  $-55^\circ\text{C}$  to  $125^\circ\text{C}$ ; Series 74LS and 74S devices are characterized for operation from  $0^\circ\text{C}$  to  $70^\circ\text{C}$ .

**signal designations**

In both Figures 1 and 2, the polarity indicators ( $\nabla$ ) indicate that the associated input or output is active-low with respect to the function shown inside the symbol, and the symbols are the same in both figures. The signal designations in Figure 1 agree with the indicated internal functions based on active-low data, and are for use with the logic functions and arithmetic operations shown in Table 1. The signal designations have been changed in Figure 2 to accommodate the logic functions and arithmetic operations for the active-high data given in Table 2. The 'LS181 and 'S181, together with the 'S182, can be used with the signal designation of either Figure 1 or Figure 2.



SN54LS181, SN54S181  
SN74LS181, SN74S181  
**ARITHMETIC LOGIC UNITS/FUNCTION GENERATORS**

SDLS136 - DECEMBER 1972 - REVISED MARCH 1988

logic symbols<sup>†</sup> and signal designations (active-low data)

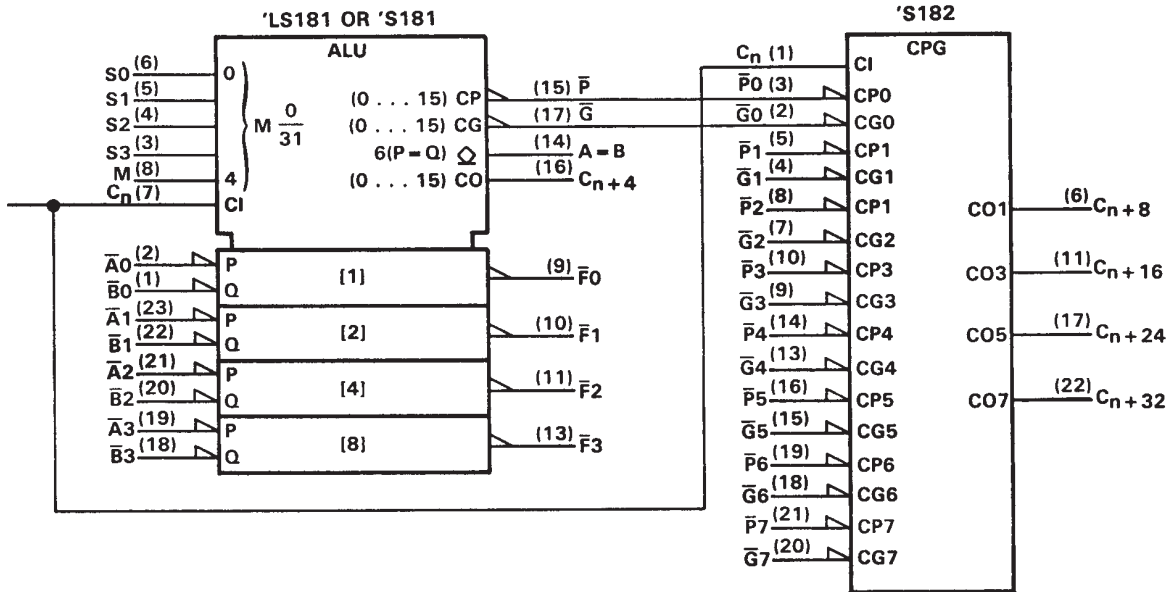

<sup>†</sup>These symbols are in accordance with ANSI/IEEE Std. 91-1984 and IEC Publication 617-12. Pin numbers shown are for dual-in-line and "small outline" packages.

FIGURE 1 (USE WITH TABLE 1)

TABLE 1

SELECTION				ACTIVE-LOW DATA		
				M = H LOGIC FUNCTIONS	M = L; ARITHMETIC OPERATIONS	
S3	S2	S1	S0		Cn = L (no carry)	Cn = H (with carry)
L	L	L	L	$F = \overline{A}$	F = A MINUS 1	F = A
L	L	L	H	$F = \overline{AB}$	F = AB MINUS 1	F = AB
L	L	H	L	$F = \overline{A + B}$	F = $\overline{AB}$ MINUS 1	F = $\overline{AB}$
L	L	H	H	F = 1	F = MINUS 1 (2's COMP)	F = ZERO
L	H	L	L	$F = \overline{A + B}$	F = A PLUS (A + $\overline{B}$ )	F = A PLUS (A + $\overline{B}$ ) PLUS 1
L	H	L	H	$F = \overline{B}$	F = AB PLUS (A + $\overline{B}$ )	F = AB PLUS (A + $\overline{B}$ ) PLUS 1
L	H	H	L	$F = A \oplus B$	F = A MINUS B MINUS 1	F = A MINUS B
L	H	H	H	$F = A + \overline{B}$	F = A + $\overline{B}$	F = (A + $\overline{B}$ ) PLUS 1
H	L	L	L	$F = \overline{AB}$	F = A PLUS (A + B)	F = A PLUS (A + B) PLUS 1
H	L	L	H	$F = A \oplus B$	F = A PLUS B	F = A PLUS B PLUS 1
H	L	H	L	F = B	F = $\overline{AB}$ PLUS (A + B)	F = $\overline{AB}$ PLUS (A + B) PLUS 1
H	L	H	H	F = A + B	F = (A + B)	F = (A + B) PLUS 1
H	H	L	L	F = 0	F = A PLUS A <sup>‡</sup>	F = A PLUS A PLUS 1
H	H	L	H	$F = \overline{AB}$	F = AB PLUS A	F = AB PLUS A PLUS 1
H	H	H	L	F = AB	F = $\overline{AB}$ PLUS A	F = $\overline{AB}$ PLUS A PLUS 1
H	H	H	H	F = A	F = A	F = A PLUS 1

<sup>‡</sup>Each bit is shifted to the next more significant position.



SN54LS181, SN54S181  
 SN74LS181, SN74S181  
 ARITHMETIC LOGIC UNITS/FUNCTION GENERATORS

SDLS136 – DECEMBER 1972 – REVISED MARCH 1988

logic symbols† and signal designations (active-high data)

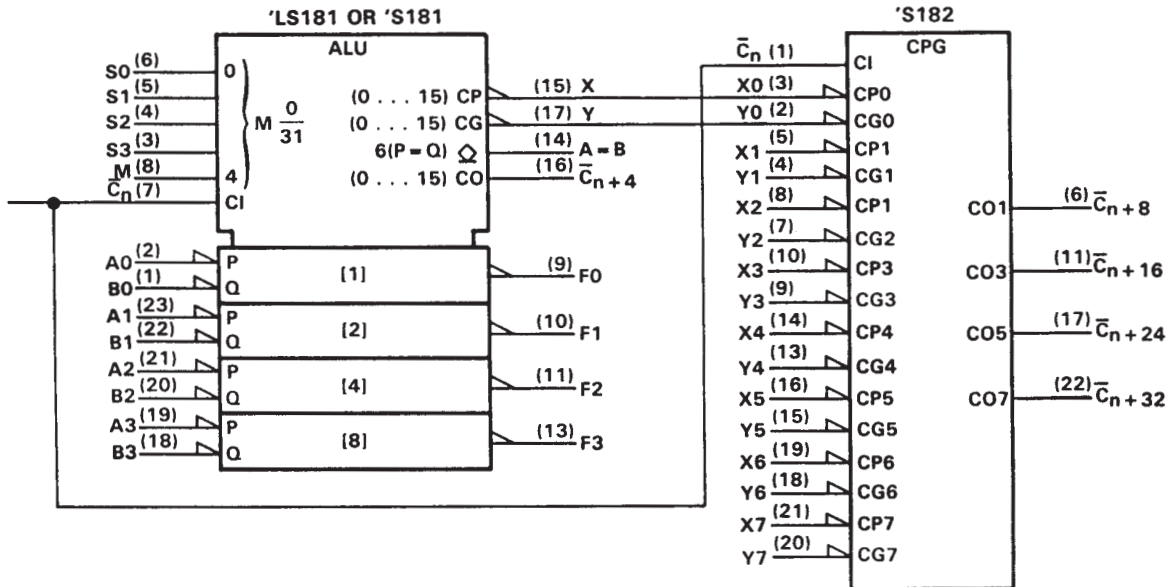

†These symbols are in accordance with ANSI/IEEE Std. 91-1984 and IEC Publication 617-12. Pin numbers shown are for dual-in-line and "small outline" packages.

FIGURE 2 (USE WITH TABLE 2)

TABLE 2

SELECTION				ACTIVE-HIGH DATA		
				M = H LOGIC FUNCTIONS	M = L; ARITHMETIC OPERATIONS	
S3	S2	S1	S0		$\bar{C}_n = H$ (no carry)	$\bar{C}_n = L$ (with carry)
L	L	L	L	$F = \bar{A}$	$F = A$	$F = A \text{ PLUS } 1$
L	L	L	H	$F = \bar{A} + B$	$F = A + B$	$F = (A + B) \text{ PLUS } 1$
L	L	H	L	$F = \bar{A}B$	$F = A + \bar{B}$	$F = (A + \bar{B}) \text{ PLUS } 1$
L	L	H	H	$F = 0$	$F = \text{MINUS } 1 \text{ (2's COMPL)}$	$F = \text{ZERO}$
L	H	L	L	$F = \bar{A}B$	$F = A \text{ PLUS } \bar{A}\bar{B}$	$F = A \text{ PLUS } \bar{A}\bar{B} \text{ PLUS } 1$
L	H	L	H	$F = \bar{B}$	$F = (A + B) \text{ PLUS } \bar{A}\bar{B}$	$F = (A + B) \text{ PLUS } \bar{A}\bar{B} \text{ PLUS } 1$
L	H	H	L	$F = A \oplus B$	$F = A \text{ MINUS } B \text{ MINUS } 1$	$F = A \text{ MINUS } B$
L	H	H	H	$F = \bar{A}\bar{B}$	$F = \bar{A}\bar{B} \text{ MINUS } 1$	$F = \bar{A}\bar{B}$
H	L	L	L	$F = \bar{A} + B$	$F = A \text{ PLUS } AB$	$F = A \text{ PLUS } AB \text{ PLUS } 1$
H	L	L	H	$F = A \oplus B$	$F = A \text{ PLUS } B$	$F = A \text{ PLUS } B \text{ PLUS } 1$
H	L	H	L	$F = B$	$F = (A + \bar{B}) \text{ PLUS } AB$	$F = (A + \bar{B}) \text{ PLUS } AB \text{ PLUS } 1$
H	L	H	H	$F = AB$	$F = AB \text{ MINUS } 1$	$F = AB$
H	H	L	L	$F = 1$	$F = A \text{ PLUS } A^\dagger$	$F = A \text{ PLUS } A \text{ PLUS } 1$
H	H	L	H	$F = A + \bar{B}$	$F = (A + B) \text{ PLUS } A$	$F = (A + B) \text{ PLUS } A \text{ PLUS } 1$
H	H	H	L	$F = A + B$	$F = (A + \bar{B}) \text{ PLUS } A$	$F = (A + \bar{B}) \text{ PLUS } A \text{ PLUS } 1$
H	H	H	H	$F = A$	$F = A \text{ MINUS } 1$	$F = A$

† Each bit is shifted to the next more significant position.

SN54LS181, SN54S181  
 SN74LS181, SN74S181  
 ARITHMETIC LOGIC UNITS/FUNCTION GENERATORS

SDLS136 - DECEMBER 1972 - REVISED MARCH 1988

logic diagram (positive logic)

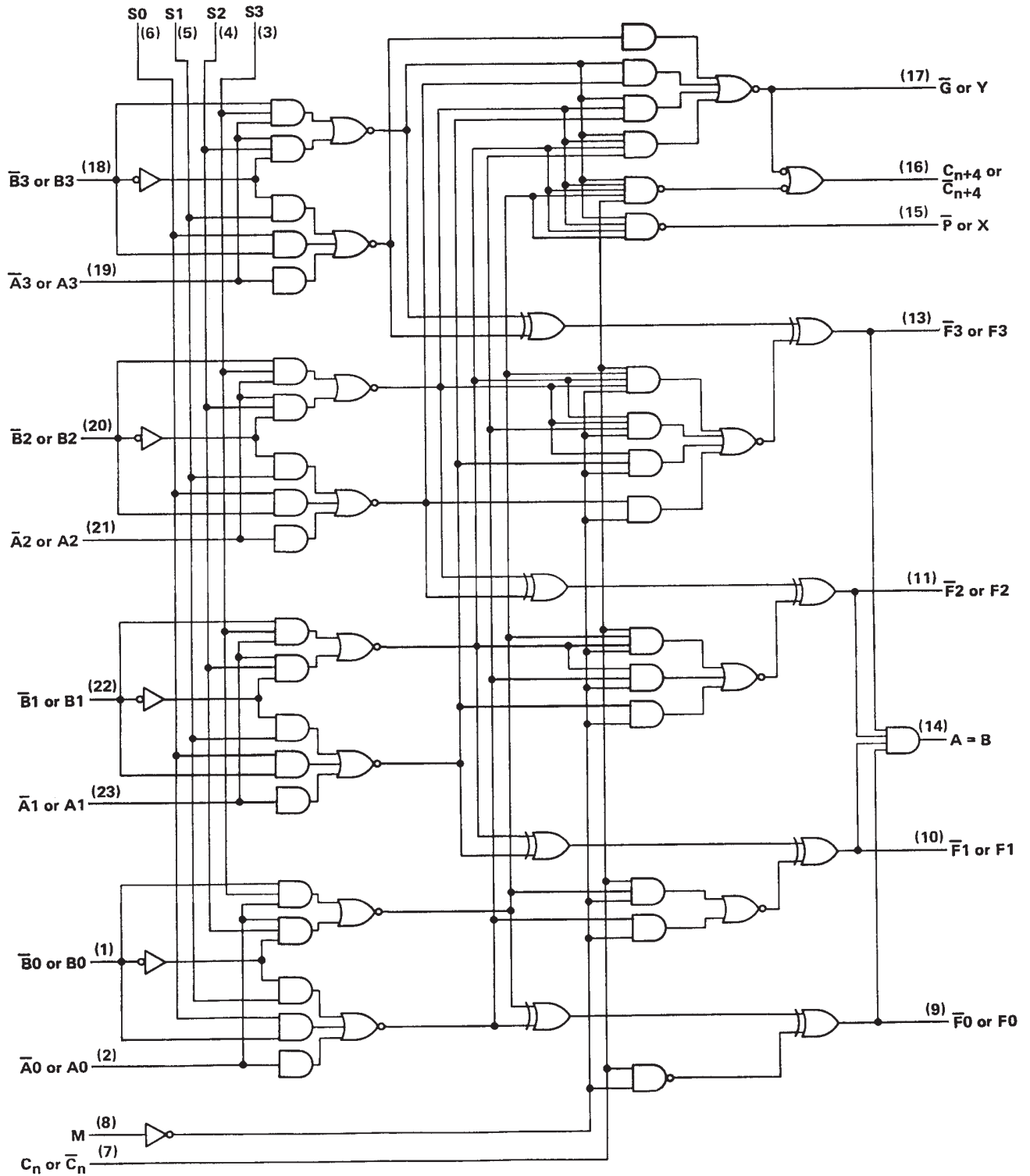

Pin numbers shown are for DW, J, N, and W packages.



**SN54LS181, SN54S181  
SN74LS181, SN74S181  
ARITHMETIC LOGIC UNITS/FUNCTION GENERATORS**

SDLS136 – DECEMBER 1972 – REVISED MARCH 1988

**absolute maximum ratings over recommended operating free-air temperature range (unless otherwise noted)**

Supply voltage, $V_{CC}$ (see Note 1)	7 V
Input voltage	5.5 V
Interemitter voltage (see Note 2)	5.5 V
Operating free-air temperature range: SN54LS181	-55°C to 125°C
SN74LS181	0°C to 70°C
Storage temperature range	-65°C to 150°C

NOTES: 1. Voltage values, except interemitter voltage, are with respect to network ground terminal.  
2. This is the voltage between two emitters of a multiple-emitter transistor. For this circuit, this rating applies to each  $\bar{A}$  input in conjunction with inputs S2 or S3, and to each  $\bar{B}$  input in conjunction with inputs S0 or S3.

**recommended operating conditions**

	SN54LS181			SN74LS181			UNIT
	MIN	NOM	MAX	MIN	NOM	MAX	
Supply voltage, $V_{CC}$	4.5	5	5.5	4.75	5	5.25	V
High-level output current, $I_{OH}$ (All outputs except A = B)			-400			-400	$\mu$ A
Low-level output current, $I_{OL}$			4			8	mA
Operating free-air temperature, $T_A$	-55		125	0		70	°C

**electrical characteristics over recommended operating free-air temperature range (unless otherwise noted)**

PARAMETER		TEST CONDITIONS†	SN54LS181			SN74LS181			UNIT
			MIN	TYP‡	MAX	MIN	TYP‡	MAX	
$V_{IH}$	High-level input voltage		2			2			V
$V_{IL}$	Low-level input voltage				0.7			0.8	V
$V_{IK}$	Input clamp voltage	$V_{CC} = \text{MIN}, I_I = -18 \text{ mA}$			-1.5			-1.5	V
$V_{OH}$	High-level output voltage, any output except A = B	$V_{CC} = \text{MIN}, V_{IH} = 2 \text{ V}, V_{IL} = V_{IL \text{ max}}, I_{OH} = -400 \mu\text{A}$	2.5	3.4		2.7	3.4		V
$I_{OH}$	High-level output current, A = B output only	$V_{CC} = \text{MIN}, V_{IH} = 2 \text{ V}, V_{IL} = V_{IL \text{ max}}, V_{OH} = 5.5 \text{ V}$		100			100		$\mu$ A
$V_{OL}$	Low-level output voltage	All outputs $V_{CC} = \text{MIN}, V_{IH} = 2 \text{ V}, V_{IL} = V_{IL \text{ max}}$	$I_{OL} = 4 \text{ mA}$		0.25	0.4	0.25	0.4	V
			$I_{OL} = 8 \text{ mA}$				0.35	0.5	
			$I_{OL} = 16 \text{ mA}$		0.47	0.7	0.47	0.7	
			$I_{OL} = 8 \text{ mA}$		0.35	0.6	0.35	0.5	
$I_I$	Input current at max. input voltage	$V_{CC} = \text{MAX}, V_I = 5.5 \text{ V}$	Mode input		0.1		0.1	mA	
			Any $\bar{A}$ or $\bar{B}$ input		0.3		0.3		
			Any S input		0.4		0.4		
			Carry input		0.5		0.5		
$I_{IH}$	High-level input current	$V_{CC} = \text{MAX}, V_I = 2.7 \text{ V}$	Mode input		20		20	$\mu$ A	
			Any $\bar{A}$ or $\bar{B}$ input		60		60		
			Any S input		80		80		
			Carry input		100		100		
$I_{IL}$	Low-level input current	$V_{CC} = \text{MAX}, V_I = 0.4 \text{ V}$	Mode input		-0.4		-0.4	mA	
			Any $\bar{A}$ or $\bar{B}$ input		-1.2		-1.2		
			Any S input		-1.6		-1.6		
			Carry input		-2		-2		
$I_{OS}$	Short-circuit output current, any output except A = B §	$V_{CC} = \text{MAX}$	-6	-40	-5	-42	mA		
$I_{CC}$	Supply current	$V_{CC} = \text{MAX},$ See Note 3	Condition A		20	32	20	34	mA
			Condition B		21	35	21	37	

† For conditions shown as MIN or MAX, use the appropriate value specified under recommended operating conditions.

‡ All typical values are at  $V_{CC} = 5 \text{ V}, T_A = 25^\circ\text{C}$ .

§ Not more than one output should be shorted at a time.

NOTE 3: With outputs open,  $I_{CC}$  is measured for the following conditions:

- A. S0 through S3, M, and  $\bar{A}$  inputs are at 4.5 V, all other inputs are grounded.
- B. S0 through S3 and M are at 4.5 V, all other inputs are grounded.



SN54LS181, SN54S181  
SN74LS181, SN74S181  
**ARITHMETIC LOGIC UNITS/FUNCTION GENERATORS**

SDLS136 - DECEMBER 1972 - REVISED MARCH 1988

switching characteristics,  $V_{CC} = 5\text{ V}$ ,  $T_A = 25^\circ\text{C}$ , ( $C_L = 15\text{ pF}$ ,  $R_L = 2\text{ k}\Omega$ , see note 4)

PARAMETER†	FROM (INPUT)	TO (OUTPUT)	TEST CONDITIONS	MIN	TYP	MAX	UNIT
t <sub>PLH</sub>	C <sub>n</sub>	C <sub>n+4</sub>		18	27		ns
t <sub>PHL</sub>				13	20		
t <sub>PLH</sub>	Any $\bar{A}$ or $\bar{B}$	C <sub>n+4</sub>	M = 0 V, S0 = S3 = 4.5 V, S1 = S2 = 0 V (SUM mode)	25	38		ns
t <sub>PHL</sub>				25	38		
t <sub>PLH</sub>	Any $\bar{A}$ or $\bar{B}$	C <sub>n+4</sub>	M = 0 V, S0 = S3 = 0 V S1 = S2 = 4.5 V (DIFF mode)	27	41		ns
t <sub>PHL</sub>				27	41		
t <sub>PLH</sub>	C <sub>n</sub>	Any $\bar{F}$	M = 0 V (SUM or DIFF mode)	17	26		ns
t <sub>PHL</sub>				13	20		
t <sub>PLH</sub>	Any $\bar{A}$ or $\bar{B}$	$\bar{G}$	M = 0 V, S0 = S3 = 4.5 V, S1 = S2 = 0 V (SUM mode)	19	29		ns
t <sub>PHL</sub>				15	23		
t <sub>PLH</sub>	Any $\bar{A}$ or $\bar{B}$	$\bar{G}$	M = 0 V, S0 = S3 = 0 V, S1 = S2 = 4.5 V (DIFF mode)	21	32		ns
t <sub>PHL</sub>				21	32		
t <sub>PLH</sub>	Any $\bar{A}$ or $\bar{B}$	$\bar{P}$	M = 0 V, S0 = S3 = 4.5 V, S1 = S2 = 0 V, (SUM mode)	20	30		ns
t <sub>PHL</sub>				20	30		
t <sub>PLH</sub>	Any $\bar{A}$ or $\bar{B}$	$\bar{P}$	M = 0 V, S0 = S3 = 0 V, S1 = S2 = 4.5 V (DIFF mode)	20	30		ns
t <sub>PHL</sub>				22	33		
t <sub>PLH</sub>	$\bar{A}_i$ or $\bar{B}_i$	$\bar{F}_i$	M = 0 V, S0 = S3 = 4.5 V, S1 = S2 = 0 V (SUM mode)	21	32		ns
t <sub>PHL</sub>				13	20		
t <sub>PLH</sub>	$\bar{A}_i$ or $\bar{B}_i$	$\bar{F}_i$	M = 0 V, S0 = S3 = 0 V, S1 = S2 = 4.5 V (DIFF mode)	21	32		ns
t <sub>PHL</sub>				21	32		
t <sub>PLH</sub>	$\bar{A}_i$ or $\bar{B}_i$	$\bar{F}_i$	M = 4.5 V (logic mode)	22	33		ns
t <sub>PHL</sub>				26	38		
t <sub>PLH</sub>	Any $\bar{A}$ or $\bar{B}$	A = B	M = 0 V, S0 = S3 = 0 V, S1 = S2 = 4.5 V (DIFF mode)	33	50		ns
t <sub>PHL</sub>				41	62		

†t<sub>PLH</sub> = propagation delay time, low-to-high-level output

t<sub>PHL</sub> = propagation delay time, high-to-low-level output

NOTE 4: Load circuits and voltage waveforms are shown in Section 1. Refer to Parameter Measurement Information page for test conditions.

schematics of inputs and outputs

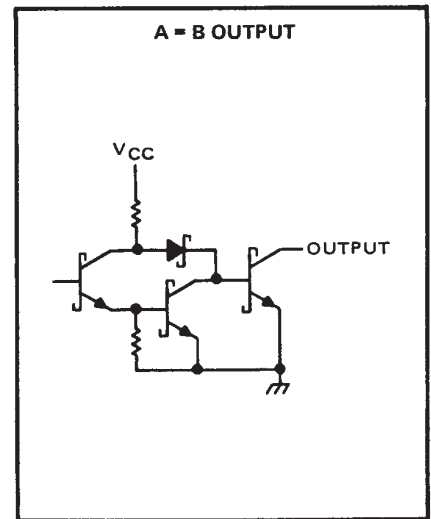
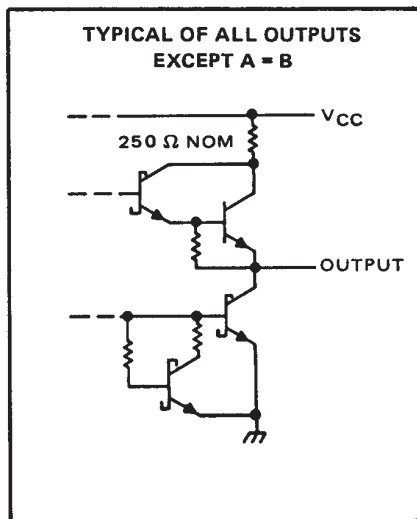
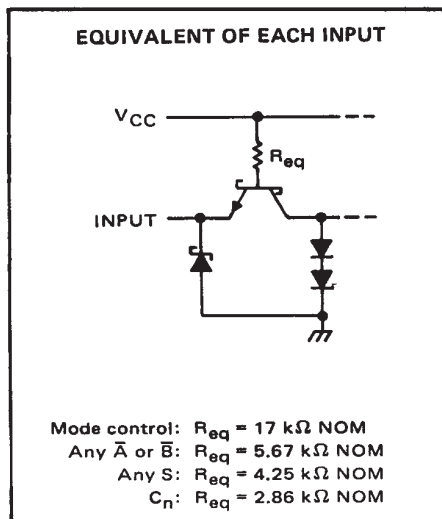

**SN54LS181, SN54S181  
SN74LS181, SN74S181  
ARITHMETIC LOGIC UNITS/FUNCTION GENERATORS**

SDLS136 – DECEMBER 1972 – REVISED MARCH 1988

**absolute maximum ratings over operating free-air temperature range (unless otherwise noted)**

Supply voltage, $V_{CC}$ (see Note 1)	7 V
Input voltage	5.5 V
Interemitter voltage (see Note 2)	5.5 V
Operating free-air temperature: SN54S181	-55°C to 125°C
SN74S181	0°C to 70°C
Storage temperature range	-65°C to 150°C

NOTES: 1. Voltage values, except interemitter voltage, are with respect to network ground terminal.  
2. This is the voltage between two emitters of a multiple-emitter transistor. For this circuit, this rating applies to each  $\bar{A}$  input in conjunction with inputs S2 or S3, and to each  $\bar{B}$  input in conjunction with inputs S0 or S3.

**recommended operating conditions**

	SN54S181			SN74S181			UNIT
	MIN	NOM	MAX	MIN	NOM	MAX	
Supply voltage, $V_{CC}$	4.5	5	5.5	4.75	5	5.25	V
High-level output current, $I_{OH}$ (All outputs except A = B)			-1			-1	mA
Low-level output current, $I_{OL}$			20			20	mA
Operating free-air temperature, $T_A$	-55		125	0		70	°C

**electrical characteristics over recommended operating free-air temperature range (unless otherwise noted)**

PARAMETER	TEST CONDITIONS†	SN54S181			SN74S181			UNIT
		MIN	TYP‡	MAX	MIN	TYP‡	MAX	
$V_{IH}$ High-level input voltage		2			2			V
$V_{IL}$ Low-level input voltage				0.8			0.8	V
$V_{IK}$ Input clamp voltage	$V_{CC} = \text{MIN}, I_I = -18 \text{ mA}$			-1.2			-1.2	V
$V_{OH}$ High-level output voltage, any output except A = B	$V_{CC} = \text{MIN}, V_{IH} = 2 \text{ V}, V_{IL} = 0.8 \text{ V}, I_{OH} = -1 \text{ mA}$	2.5	3.4		2.7	3.4		V
$I_{OH}$ High-level output current, A = B output only	$V_{CC} = \text{MIN}, V_{IH} = 2 \text{ V}, V_{IL} = 0.8 \text{ V}, V_{OH} = 5.5 \text{ V}$			250			250	µA
$V_{OL}$ Low-level output voltage	$V_{CC} = \text{MIN}, V_{IH} = 2 \text{ V}, V_{IL} = 0.8 \text{ V}, I_{OL} = 20 \text{ mA}$			0.5			0.5	V
$I_I$ Input current at maximum input voltage	$V_{CC} = \text{MAX}, V_I = 5.5 \text{ V}$			1			1	mA
$I_{IH}$ High-level input current	Mode input			50			50	µA
	Any $\bar{A}$ or $\bar{B}$ input	$V_{CC} = \text{MAX}, V_I = 2.5 \text{ V}$		150			150	
	Any S input			200			200	
	Carry input			250			250	
$I_{IL}$ Low-level input current	Mode input		$V_{CC} = \text{MAX}, V_I = 0.5 \text{ V}$		-2			-2
	Any $\bar{A}$ or $\bar{B}$ input			-6			-6	
	Any S input			-8			-8	
	Carry input			-10			-10	
$I_{OS}$ Short-circuit output current, any output except A = B §	$V_{CC} = \text{MAX}$			-40		-100		mA
$I_{CC}$ Supply current	$V_{CC} = \text{MAX}, T_A = 125^\circ\text{C},$ See Note 3	W package only		195				mA
	$V_{CC} = \text{MAX},$ See Note 3	All packages		120 220		120 220		

† For conditions shown as MIN or MAX, use the appropriate value specified under recommended operating conditions.

‡ All typical values are at  $V_{CC} = 5 \text{ V}, T_A = 25^\circ\text{C}$ .

§ Not more than one output should be shorted at a time.

NOTE 3:  $I_{CC}$  is measured for the following conditions (the typical and maximum values apply to both):

A. S0 through S3, M, and  $\bar{A}$  inputs are at 4.5 V, all other inputs are grounded, and all outputs are open.

B. S0 through S3 and M are at 4.5 V, all other inputs grounded, and all outputs are open.





SN54LS181, SN54S181  
SN74LS181, SN74S181  
**ARITHMETIC LOGIC UNITS/FUNCTION GENERATORS**

SDLS136 – DECEMBER 1972 – REVISED MARCH 1988

switching characteristics,  $V_{CC} = 5\text{ V}$ ,  $T_A = 25^\circ\text{C}$  ( $C_L = 15\text{ pF}$ ,  $R_L = 280\ \Omega$ , see note 4)

PARAMETER†	FROM (INPUT)	TO (OUTPUT)	TEST CONDITIONS	MIN	TYP	MAX	UNIT
$t_{PLH}$	$C_n$	$C_{n+4}$		7	10.5	ns	
$t_{PHL}$				7	10.5		
$t_{PLH}$	Any $\bar{A}$ or $\bar{B}$	$C_{n+4}$	$M = 0\text{ V}$ , $S_0 = S_3 = 4.5\text{ V}$ , $S_1 = S_2 = 0\text{ V}$ (SUM mode)	12.5	18.5	ns	
$t_{PHL}$				12.5	18.5		
$t_{PLH}$	Any $\bar{A}$ or $\bar{B}$	$C_{n+4}$	$M = 0\text{ V}$ , $S_0 = S_3 = 0\text{ V}$ , $S_1 = S_2 = 4.5\text{ V}$ (DIFF mode)	15.5	23	ns	
$t_{PHL}$				15.5	23		
$t_{PLH}$	$C_n$	Any $\bar{F}$	$M = 0\text{ V}$ (SUM or DIFF mode)	7	12	ns	
$t_{PHL}$				7	12		
$t_{PLH}$	Any $\bar{A}$ or $\bar{B}$	$\bar{G}$	$M = 0\text{ V}$ , $S_0 = S_3 = 4.5\text{ V}$ , $S_1 = S_2 = 0\text{ V}$ (SUM mode)	8	12	ns	
$t_{PHL}$				7.5	12		
$t_{PLH}$	Any $\bar{A}$ or $\bar{B}$	$\bar{G}$	$M = 0\text{ V}$ , $S_0 = S_3 = 0\text{ V}$ , $S_1 = S_2 = 4.5\text{ V}$ (DIFF mode)	10.5	15	ns	
$t_{PHL}$				10.5	15		
$t_{PLH}$	Any $\bar{A}$ or $\bar{B}$	$\bar{P}$	$M = 0\text{ V}$ , $S_0 = S_3 = 4.5\text{ V}$ , $S_1 = S_2 = 0\text{ V}$ (SUM mode)	7.5	12	ns	
$t_{PHL}$				7.5	12		
$t_{PLH}$	Any $\bar{A}$ or $\bar{B}$	$\bar{P}$	$M = 0\text{ V}$ , $S_0 = S_3 = 0\text{ V}$ , $S_1 = S_2 = 4.5\text{ V}$ (DIFF mode)	10.5	15	ns	
$t_{PHL}$				10.5	15		
$t_{PLH}$	$\bar{A}_i$ or $\bar{B}_i$	$\bar{F}_i$	$M = 0\text{ V}$ , $S_0 = S_3 = 4.5\text{ V}$ , $S_1 = S_2 = 0\text{ V}$ (SUM mode)	11	16.5	ns	
$t_{PHL}$				11	16.5		
$t_{PLH}$	$\bar{A}_i$ or $\bar{B}_i$	$F_i$	$M = 0\text{ V}$ , $S_0 = S_3 = 0\text{ V}$ , $S_1 = S_2 = 4.5\text{ V}$ (DIFF mode)	14	20	ns	
$t_{PHL}$				14	22		
$t_{PLH}$	$\bar{A}_i$ or $\bar{B}_i$	$\bar{F}_i$	$M = 4.5\text{ V}$ (logic mode)	14	20	ns	
$t_{PHL}$				14	22		
$t_{PLH}$	Any $\bar{A}$ or $\bar{B}$	$A = B$	$M = 0\text{ V}$ , $S_0 = S_3 = 0\text{ V}$ , $S_1 = S_2 = 4.5\text{ V}$ (DIFF mode)	15	23	ns	
$t_{PHL}$				20	30		

† $t_{PLH}$  = propagation delay time, low-to-high-level output

$t_{PHL}$  = propagation delay time, high-to-low-level output

NOTE 4: Load circuits and voltage waveforms are shown in Section 1. Refer to Parameter Measurement Information page for test conditions.

schematics of inputs and outputs

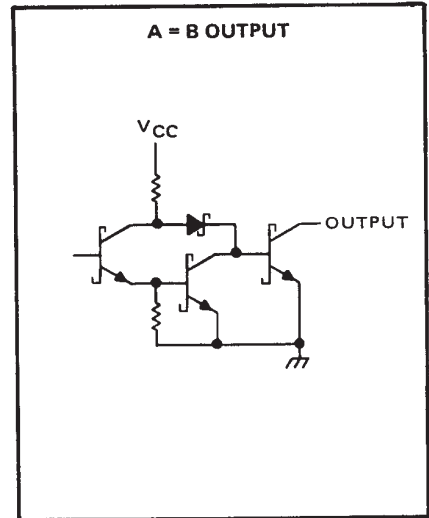
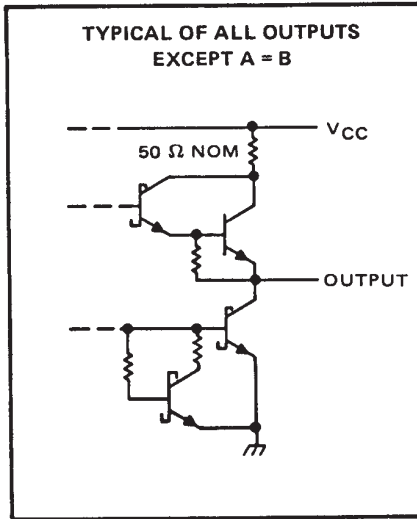
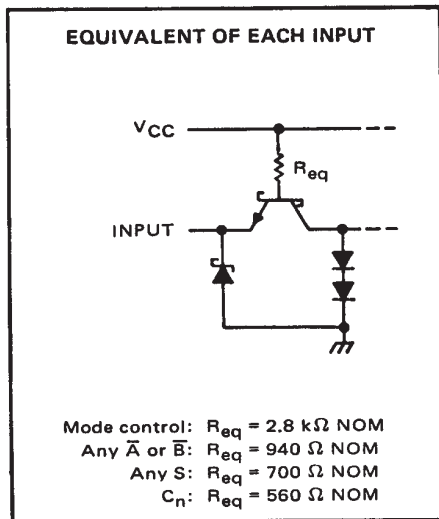

SN54LS181, SN54S181  
 SN74LS181, SN74S181  
 ARITHMETIC LOGIC UNITS/FUNCTION GENERATORS

SDLS136 – DECEMBER 1972 – REVISED MARCH 1988

PARAMETER MEASUREMENT INFORMATION

SUM MODE TEST TABLE

FUNCTION INPUTS: S0 = S3 = 4.5 V, S1 = S2 = M = 0 V

PARAMETER	INPUT UNDER TEST	OTHER INPUT SAME BIT		OTHER DATA INPUTS		OUTPUT UNDER TEST	OUTPUT WAVEFORM (See Note 4)
		APPLY 4.5 V	APPLY GND	APPLY 4.5 V	APPLY GND		
<sup>t</sup> PLH	$\bar{A}_i$	$\bar{B}_i$	None	Remaining $\bar{A}$ and $\bar{B}$	$C_n$	$\bar{F}_i$	In-Phase
<sup>t</sup> PHL	$\bar{A}_i$	$\bar{B}_i$	None	Remaining $\bar{A}$ and $\bar{B}$	$C_n$	$\bar{F}_i$	In-Phase
<sup>t</sup> PLH	$\bar{B}_i$	$\bar{A}_i$	None	Remaining $\bar{A}$ and $\bar{B}$	$C_n$	$\bar{F}_i$	In-Phase
<sup>t</sup> PHL	$\bar{B}_i$	$\bar{A}_i$	None	Remaining $\bar{A}$ and $\bar{B}$	$C_n$	$\bar{F}_i$	In-Phase
<sup>t</sup> PLH	$\bar{A}_i$	$\bar{B}_i$	None	None	Remaining $\bar{A}$ and $\bar{B}$ , $C_n$	$\bar{P}$	In-Phase
<sup>t</sup> PHL	$\bar{A}_i$	$\bar{B}_i$	None	None	Remaining $\bar{A}$ and $\bar{B}$ , $C_n$	$\bar{P}$	In-Phase
<sup>t</sup> PLH	$\bar{B}_i$	$\bar{A}_i$	None	None	Remaining $\bar{A}$ and $\bar{B}$ , $C_n$	$\bar{P}$	In-Phase
<sup>t</sup> PHL	$\bar{B}_i$	$\bar{A}_i$	None	None	Remaining $\bar{A}$ and $\bar{B}$ , $C_n$	$\bar{P}$	In-Phase
<sup>t</sup> PLH	$\bar{A}_i$	None	$\bar{B}_i$	Remaining $\bar{B}$	Remaining $\bar{A}$ , $C_n$	$\bar{G}$	In-Phase
<sup>t</sup> PHL	$\bar{A}_i$	None	$\bar{B}_i$	Remaining $\bar{B}$	Remaining $\bar{A}$ , $C_n$	$\bar{G}$	In-Phase
<sup>t</sup> PLH	$\bar{B}_i$	None	$\bar{A}_i$	Remaining $\bar{B}$	Remaining $\bar{A}$ , $C_n$	$\bar{G}$	In-Phase
<sup>t</sup> PHL	$\bar{B}_i$	None	$\bar{A}_i$	Remaining $\bar{B}$	Remaining $\bar{A}$ , $C_n$	$\bar{G}$	In-Phase
<sup>t</sup> PLH	$C_n$	None	None	All $\bar{A}$	All $\bar{B}$	Any $\bar{F}$ or $C_{n+4}$	In-Phase
<sup>t</sup> PHL	$C_n$	None	None	All $\bar{A}$	All $\bar{B}$	Any $\bar{F}$ or $C_{n+4}$	In-Phase
<sup>t</sup> PLH	$\bar{A}_i$	None	$\bar{B}_i$	Remaining $\bar{B}$	Remaining $\bar{A}$ , $C_n$	$C_{n+4}$	Out-of-Phase
<sup>t</sup> PHL	$\bar{A}_i$	None	$\bar{B}_i$	Remaining $\bar{B}$	Remaining $\bar{A}$ , $C_n$	$C_{n+4}$	Out-of-Phase
<sup>t</sup> PLH	$\bar{B}_i$	None	$\bar{A}_i$	Remaining $\bar{B}$	Remaining $\bar{A}$ , $C_n$	$C_{n+4}$	Out-of-Phase
<sup>t</sup> PHL	$\bar{B}_i$	None	$\bar{A}_i$	Remaining $\bar{B}$	Remaining $\bar{A}$ , $C_n$	$C_{n+4}$	Out-of-Phase

DIFF MODE TEST TABLE

FUNCTION INPUTS: S1 = S2 = 4.5 V, S0 = S3 = M = 0 V

PARAMETER	INPUT UNDER TEST	OTHER INPUT SAME BIT		OTHER DATA INPUTS		OUTPUT UNDER TEST	OUTPUT WAVEFORM (See Note 4)
		APPLY 4.5 V	APPLY GND	APPLY 4.5 V	APPLY GND		
<sup>t</sup> PLH	$\bar{A}_i$	None	$\bar{B}_i$	Remaining $\bar{A}$	Remaining $\bar{B}$ , $C_n$	$\bar{F}_i$	In-Phase
<sup>t</sup> PHL	$\bar{A}_i$	None	$\bar{B}_i$	Remaining $\bar{A}$	Remaining $\bar{B}$ , $C_n$	$\bar{F}_i$	In-Phase
<sup>t</sup> PLH	$\bar{B}_i$	$\bar{A}_i$	None	Remaining $\bar{A}$	Remaining $\bar{B}$ , $C_n$	$\bar{F}_i$	Out-of-Phase
<sup>t</sup> PHL	$\bar{B}_i$	$\bar{A}_i$	None	Remaining $\bar{A}$	Remaining $\bar{B}$ , $C_n$	$\bar{F}_i$	Out-of-Phase
<sup>t</sup> PLH	$\bar{A}_i$	None	$\bar{B}_i$	None	Remaining $\bar{A}$ and $\bar{B}$ , $C_n$	$\bar{P}$	In-Phase
<sup>t</sup> PHL	$\bar{A}_i$	None	$\bar{B}_i$	None	Remaining $\bar{A}$ and $\bar{B}$ , $C_n$	$\bar{P}$	In-Phase
<sup>t</sup> PLH	$\bar{B}_i$	$\bar{A}_i$	None	None	Remaining $\bar{A}$ and $\bar{B}$ , $C_n$	$\bar{P}$	Out-of-Phase
<sup>t</sup> PHL	$\bar{B}_i$	$\bar{A}_i$	None	None	Remaining $\bar{A}$ and $\bar{B}$ , $C_n$	$\bar{P}$	Out-of-Phase
<sup>t</sup> PLH	$\bar{A}_i$	$\bar{B}_i$	None	None	Remaining $\bar{A}$ and $\bar{B}$ , $C_n$	$\bar{G}$	In-Phase
<sup>t</sup> PHL	$\bar{A}_i$	$\bar{B}_i$	None	None	Remaining $\bar{A}$ and $\bar{B}$ , $C_n$	$\bar{G}$	In-Phase
<sup>t</sup> PLH	$\bar{B}_i$	None	$\bar{A}_i$	None	Remaining $\bar{A}$ and $\bar{B}$ , $C_n$	$\bar{G}$	Out-of-Phase
<sup>t</sup> PHL	$\bar{B}_i$	None	$\bar{A}_i$	None	Remaining $\bar{A}$ and $\bar{B}$ , $C_n$	$\bar{G}$	Out-of-Phase
<sup>t</sup> PLH	$\bar{A}_i$	None	$\bar{B}_i$	Remaining $\bar{A}$	Remaining $\bar{B}$ , $C_n$	A = B	In-Phase
<sup>t</sup> PHL	$\bar{A}_i$	None	$\bar{B}_i$	Remaining $\bar{A}$	Remaining $\bar{B}$ , $C_n$	A = B	In-Phase
<sup>t</sup> PLH	$\bar{B}_i$	$\bar{A}_i$	None	Remaining $\bar{A}$	Remaining $\bar{B}$ , $C_n$	A = B	Out-of-Phase
<sup>t</sup> PHL	$\bar{B}_i$	$\bar{A}_i$	None	Remaining $\bar{A}$	Remaining $\bar{B}$ , $C_n$	A = B	Out-of-Phase
<sup>t</sup> PLH	$C_n$	None	None	All $\bar{A}$ and $\bar{B}$	None	$C_{n+4}$ or any $\bar{F}$	In-Phase
<sup>t</sup> PHL	$C_n$	None	None	All $\bar{A}$ and $\bar{B}$	None	$C_{n+4}$ or any $\bar{F}$	In-Phase
<sup>t</sup> PLH	$\bar{A}_i$	$\bar{B}_i$	None	None	Remaining $\bar{A}$ , $\bar{B}$ , $C_n$	$C_{n+4}$	Out-of-Phase
<sup>t</sup> PHL	$\bar{A}_i$	$\bar{B}_i$	None	None	Remaining $\bar{A}$ , $\bar{B}$ , $C_n$	$C_{n+4}$	Out-of-Phase
<sup>t</sup> PLH	$\bar{B}_i$	None	$\bar{A}_i$	None	Remaining $\bar{A}$ , $\bar{B}$ , $C_n$	$C_{n+4}$	Out-of-Phase
<sup>t</sup> PHL	$\bar{B}_i$	None	$\bar{A}_i$	None	Remaining $\bar{A}$ , $\bar{B}$ , $C_n$	$C_{n+4}$	Out-of-Phase

LOGIC MODE TEST TABLE

FUNCTION INPUTS: S1 = S2 = M = 4.5 V, S0 = S3 = 0 V

PARAMETER	INPUT UNDER TEST	OTHER INPUT SAME BIT		OTHER DATA INPUTS		OUTPUT UNDER TEST	OUTPUT WAVEFORM (See Note 4)
		APPLY 4.5 V	APPLY GND	APPLY 4.5 V	APPLY GND		
<sup>t</sup> PLH	$\bar{A}_i$	$\bar{B}_i$	None	None	Remaining $\bar{A}$ and $\bar{B}$ , $C_n$	$\bar{F}_i$	Out-of-Phase
<sup>t</sup> PHL	$\bar{A}_i$	$\bar{B}_i$	None	None	Remaining $\bar{A}$ and $\bar{B}$ , $C_n$	$\bar{F}_i$	Out-of-Phase
<sup>t</sup> PLH	$\bar{B}_i$	$\bar{A}_i$	None	None	Remaining $\bar{A}$ and $\bar{B}$ , $C_n$	$\bar{F}_i$	Out-of-Phase
<sup>t</sup> PHL	$\bar{B}_i$	$\bar{A}_i$	None	None	Remaining $\bar{A}$ and $\bar{B}$ , $C_n$	$\bar{F}_i$	Out-of-Phase

NOTE 4: Load circuits and voltage waveforms are shown in Section 1.



**PACKAGING INFORMATION**

Orderable part number	Status (1)	Material type (2)	Package   Pins	Package qty   Carrier	RoHS (3)	Lead finish/ Ball material (4)	MSL rating/ Peak reflow (5)	Op temp (°C)	Part marking (6)
<a href="#">JM38510/07801BJA</a>	Active	Production	CDIP (J)   24	15   TUBE	No	Call TI	N/A for Pkg Type	-55 to 125	JM38510/ 07801BJA
JM38510/07801BJA.A	Active	Production	CDIP (J)   24	15   TUBE	No	Call TI	N/A for Pkg Type	-55 to 125	JM38510/ 07801BJA
<a href="#">M38510/07801BJA</a>	Active	Production	CDIP (J)   24	15   TUBE	No	Call TI	N/A for Pkg Type	-55 to 125	JM38510/ 07801BJA
<a href="#">SN54LS181J</a>	Active	Production	CDIP (J)   24	15   TUBE	No	Call TI	N/A for Pkg Type	-55 to 125	SN54LS181J
SN54LS181J.A	Active	Production	CDIP (J)   24	15   TUBE	No	Call TI	N/A for Pkg Type	-55 to 125	SN54LS181J
<a href="#">SNJ54LS181J</a>	Active	Production	CDIP (J)   24	15   TUBE	No	Call TI	N/A for Pkg Type	-55 to 125	SNJ54LS181J
SNJ54LS181J.A	Active	Production	CDIP (J)   24	15   TUBE	No	Call TI	N/A for Pkg Type	-55 to 125	SNJ54LS181J

(1) **Status:** For more details on status, see our [product life cycle](#).

(2) **Material type:** When designated, preproduction parts are prototypes/experimental devices, and are not yet approved or released for full production. Testing and final process, including without limitation quality assurance, reliability performance testing, and/or process qualification, may not yet be complete, and this item is subject to further changes or possible discontinuation. If available for ordering, purchases will be subject to an additional waiver at checkout, and are intended for early internal evaluation purposes only. These items are sold without warranties of any kind.

(3) **RoHS values:** Yes, No, RoHS Exempt. See the [TI RoHS Statement](#) for additional information and value definition.

(4) **Lead finish/Ball material:** Parts may have multiple material finish options. Finish options are separated by a vertical ruled line. Lead finish/Ball material values may wrap to two lines if the finish value exceeds the maximum column width.

(5) **MSL rating/Peak reflow:** The moisture sensitivity level ratings and peak solder (reflow) temperatures. In the event that a part has multiple moisture sensitivity ratings, only the lowest level per JEDEC standards is shown. Refer to the shipping label for the actual reflow temperature that will be used to mount the part to the printed circuit board.

(6) **Part marking:** There may be an additional marking, which relates to the logo, the lot trace code information, or the environmental category of the part.

Multiple part markings will be inside parentheses. Only one part marking contained in parentheses and separated by a "~" will appear on a part. If a line is indented then it is a continuation of the previous line and the two combined represent the entire part marking for that device.

**Important Information and Disclaimer:** The information provided on this page represents TI's knowledge and belief as of the date that it is provided. TI bases its knowledge and belief on information provided by third parties, and makes no representation or warranty as to the accuracy of such information. Efforts are underway to better integrate information from third parties. TI has taken and continues to take reasonable steps to provide representative

and accurate information but may not have conducted destructive testing or chemical analysis on incoming materials and chemicals. TI and TI suppliers consider certain information to be proprietary, and thus CAS numbers and other limited information may not be available for release.

In no event shall TI's liability arising out of such information exceed the total purchase price of the TI part(s) at issue in this document sold by TI to Customer on an annual basis.

J (R-GDIP-T\*\*)

CERAMIC DUAL-IN-LINE PACKAGE

24 PINS SHOWN

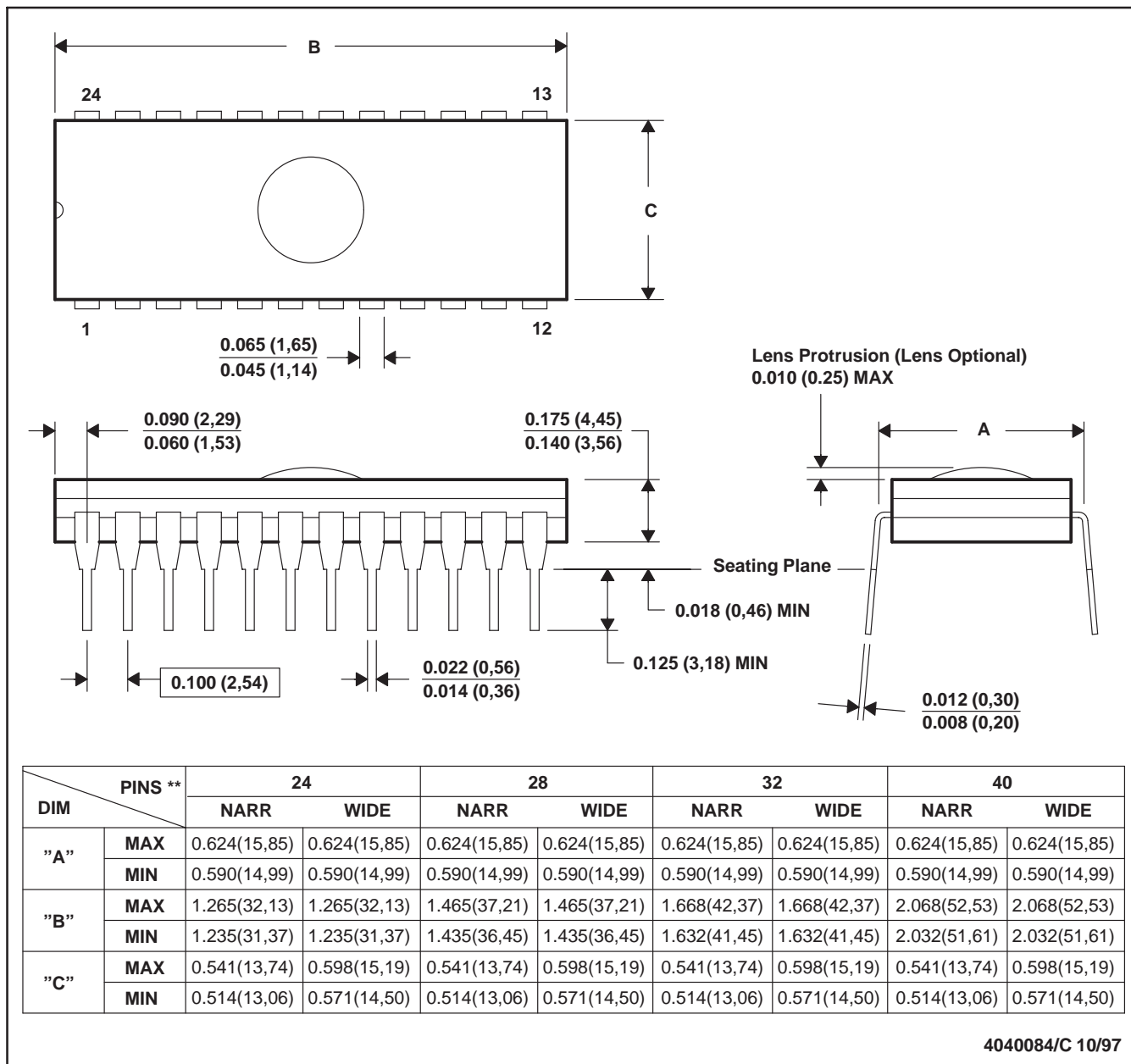

- NOTES: A. All linear dimensions are in inches (millimeters).  
 B. This drawing is subject to change without notice.  
 C. Window (lens) added to this group of packages (24-, 28-, 32-, 40-pin).  
 D. This package can be hermetically sealed with a ceramic lid using glass frit.  
 E. Index point is provided on cap for terminal identification.

## IMPORTANT NOTICE AND DISCLAIMER

TI PROVIDES TECHNICAL AND RELIABILITY DATA (INCLUDING DATASHEETS), DESIGN RESOURCES (INCLUDING REFERENCE DESIGNS), APPLICATION OR OTHER DESIGN ADVICE, WEB TOOLS, SAFETY INFORMATION, AND OTHER RESOURCES "AS IS" AND WITH ALL FAULTS, AND DISCLAIMS ALL WARRANTIES, EXPRESS AND IMPLIED, INCLUDING WITHOUT LIMITATION ANY IMPLIED WARRANTIES OF MERCHANTABILITY, FITNESS FOR A PARTICULAR PURPOSE OR NON-INFRINGEMENT OF THIRD PARTY INTELLECTUAL PROPERTY RIGHTS.

These resources are intended for skilled developers designing with TI products. You are solely responsible for (1) selecting the appropriate TI products for your application, (2) designing, validating and testing your application, and (3) ensuring your application meets applicable standards, and any other safety, security, regulatory or other requirements.

These resources are subject to change without notice. TI grants you permission to use these resources only for development of an application that uses the TI products described in the resource. Other reproduction and display of these resources is prohibited. No license is granted to any other TI intellectual property right or to any third party intellectual property right. TI disclaims responsibility for, and you fully indemnify TI and its representatives against any claims, damages, costs, losses, and liabilities arising out of your use of these resources.

TI's products are provided subject to [TI's Terms of Sale](#), [TI's General Quality Guidelines](#), or other applicable terms available either on [ti.com](#) or provided in conjunction with such TI products. TI's provision of these resources does not expand or otherwise alter TI's applicable warranties or warranty disclaimers for TI products. Unless TI explicitly designates a product as custom or customer-specified, TI products are standard, catalog, general purpose devices.

TI objects to and rejects any additional or different terms you may propose.

Copyright © 2025, Texas Instruments Incorporated

Last updated 10/2025