



24 V, EIGHT-CHANNEL DIGITAL-INPUT SERIALIZER

FEATURES

- **Eight Sensor Inputs**
 - High Input Voltage up to 30 V
 - Selectable Debounce Filters From 0 ms to 3 ms
 - Adjustable Current Limits From 0.2 mA to 5.2 mA
 - Field Inputs and Supply Lines Protected to 15-kV HBM
- **Output Drivers for External Status LEDs**
- **Cascadable for More Inputs in Multiples of Eight**

- **SPI-Compatible Interface**
- **Regulated 5-V Output for External Digital Isolator**
- **Over-Temperature and Low-Supply Voltage Indicator**

APPLICATIONS

- **Sensor Inputs for Industrial Automation and Process Control**
 - IEC61131-2 Type 1, 2, or 3 Switches
 - EN60947-5-2 Proximity Switches
- **High Channel Count Digital Input Modules for PC and PLC Systems**
- **Decentralized I/O Modules**

DESCRIPTION

The SN65HVS880 is a 24-V, eight-channel, digital-input serializer for high-channel density digital input modules of PC and PLC based systems in industrial automation. In combination with galvanic isolators the device completes the interface between the 24-V sensor outputs of the field-side and the low-voltage controller inputs at the control-side. Input signals provided by EN60947-5-2 compliant 2- and 3-wire proximity switches are current-limited and then validated by internal debounce filters. The input switching characteristic is in accordance with IEC61131-2 for Type 1, 2, and 3 sensor switches.

Upon the application of load and clock signals, input data is latched in parallel into the shift register and afterwards clocked out serially via a subsequent isolator into a serial PLC input.

Cascading of multiple SN65HVS880 is possible by connecting the serial output of the leading device with the serial input of the following device, enabling the design of high-channel count input modules. Input status is indicated via 3-mA constant current LED outputs. An external precision resistor is required to set the internal reference current. The integrated voltage regulator provides a 5-V output to supply low-power isolators. An on-chip temperature sensor together with an internal supply voltage monitor provides a chip-okay (CHOK) indication.

The SN65HVS880 comes in a 28-pin PWP PowerPAD™ package allowing for efficient heat dissipation. The device is specified for operation at temperatures from –40°C to 85°C.



Please be aware that an important notice concerning availability, standard warranty, and use in critical applications of Texas Instruments semiconductor products and disclaimers thereto appears at the end of this data sheet.

PowerPAD is a trademark of Texas Instruments.

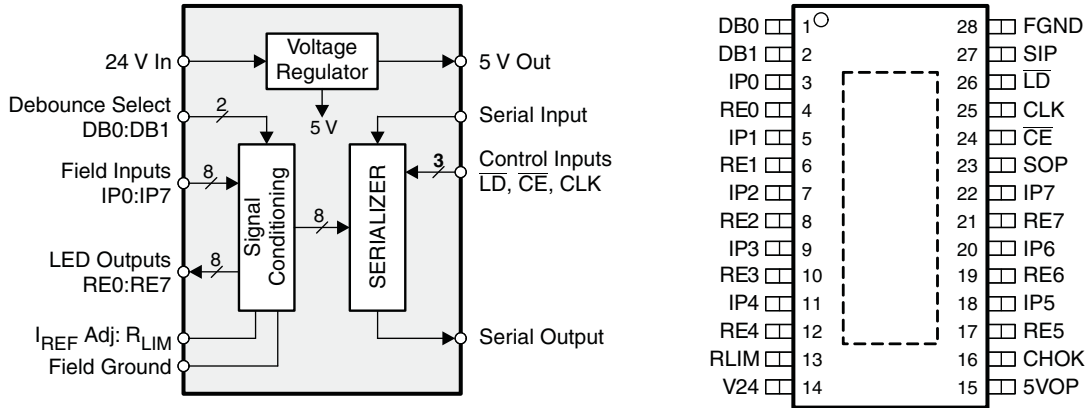

FUNCTIONAL BLOCK DIAGRAM

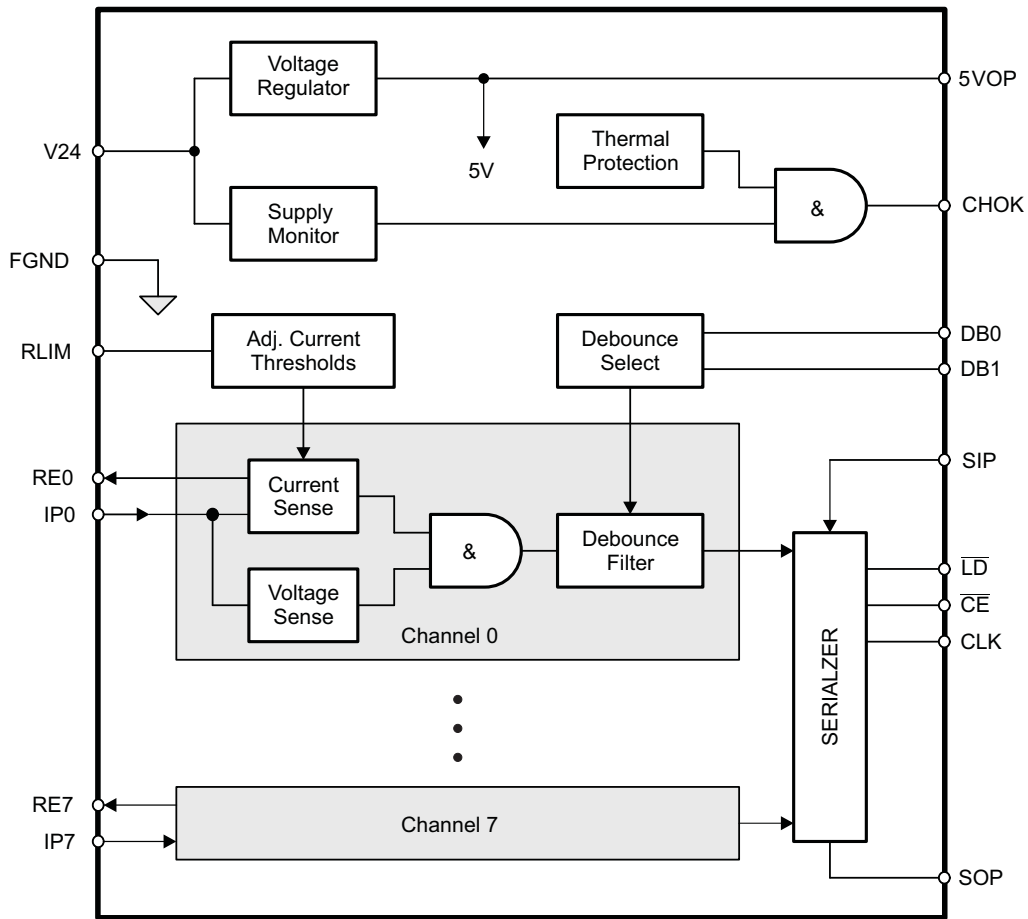

TERMINAL FUNCTIONS

TERMINAL		DESCRIPTION
PIN NO.	NAME	
1, 2	DB0, DB1	Debounce select inputs
3, 5, 7, 9, 11, 18, 20, 22	IPx	Input channel x
4, 6, 8, 10, 12, 17, 19, 21	REx	Return path x (LED drive)
13	RLIM	Current limiting resistor
14	V24	24 VDC field supply
15	5VOP	5 V output to supply low-power isolators
16	CHOK	Chip okay indicator output
23	SOP	Serial data output
24	\overline{CE}	Clock enable input
25	CLK	Serial clock input
26	\overline{LD}	Load pulse input
27	SIP	Serial data input
28	FGND	Field ground

ABSOLUTE MAXIMUM RATINGS

over operating free-air temperature range (unless otherwise noted)

		MIN	MAX	UNIT	
V ₂₄	Field power input	V ₂₄	-0.3	35	V
V _{IPx}	Field digital inputs	IPx	-0.3	35	V
V _{ID}	Voltage at any logic input	DB0, DB1, CLK, SIP, \overline{CE} , \overline{LD}	-0.5	6	V
I _O	Output current	CHOK, SOP		±8	mA
V _{ESD}	Electrostatic discharge	Human-Body Model ⁽¹⁾	All pins	±4	kV
			IPx, V ₂₄	±15	
		Charged-Device Model ⁽²⁾	All pins	±1	kV
			Machine Model ⁽³⁾	All pins	±100
P _{TOT}	Continuous total power dissipation	See Thermal Characteristics table			
T _J	Junction temperature		170		°C

(1) JEDEC Standard 22, Method A114-A.

(2) JEDEC Standard 22, Method C101

(3) JEDEC Standard 22, Method A115-A

THERMAL CHARACTERISTICS

PARAMETER	TEST CONDITIONS	MIN	TYP	MAX	UNIT
θ _{JA}	Junction-to-air thermal resistance	High-K thermal resistance		35	°C/W
θ _{JB}	Junction-to-board thermal resistance			15	°C/W
θ _{JC}	Junction-to-case thermal resistance			4.27	°C/W
PD	Device power dissipation	I _{LOAD} = 50 mA, R _{IN} = 0, IPO–IP7 = V ₂₄ = 30 V, RE7 = FGND, f _{CLK} = 100 MHz, I _{P-LIM} and I _{CC} = worst case with R _{LIM} = 25 kΩ		2591	mW

RECOMMENDED OPERATING CONDITIONS

		MIN	TYP	MAX	UNIT
V ₂₄	Field supply voltage	18	24	30	V
V _{IPL}	Field input low-state input voltage ⁽¹⁾	0		6	V
V _{IPH}	Field input high-state input voltage ⁽¹⁾	10		30	V
V _{IL}	Logic low-state input voltage	0		0.8	V
V _{IH}	Logic high-state input voltage	2		5.5	V
R _{LIM}	Current limiter resistor	17	25	500	kΩ
f _{IP}	Input data rate ⁽²⁾	0		1	Mbps
T _J				150	°C
T _A		-40		85	°C

(1) Field input voltages correspond to an input resistor of R_{IN} = 1.2 kΩ

(2) Maximum data rate corresponds to 0 ms debounce time, (DB0 = open, DB1 = FGND), and R_{IN} = 0 Ω

ELECTRICAL CHARACTERISTICS

 all voltages measured against FGND unless otherwise stated, see [Figure 12](#)

SYMBOL	PARAMETER	TERMINAL	TEST CONDITIONS	MIN	TYP	MAX	UNIT
$V_{TH-(IP)}$	Low-level device input threshold voltage	IP0–IP7	18 V < V_{24} < 30 V, $R_{IN} = 0 \Omega$	4	4.3		V
$V_{TH+(IP)}$	High-level device input threshold voltage				5.2	5.5	V
$V_{HYS(IP)}$	Device input hysteresis				0.9		V
$V_{TH-(IN)}$	Low-level field input threshold voltage	measured at field side of R_{IN}	18 V < V_{24} < 30 V, $R_{IN} = 1.2 \text{ k}\Omega \pm 5\%$, $R_{LIM} = 25 \text{ k}\Omega$	6	8.4		V
$V_{TH+(IN)}$	High-level field input threshold voltage				9.4	10	V
$V_{HYS(IN)}$	Field input hysteresis				1		V
$V_{TH-(V24)}$	Low-level V24-monitor threshold voltage	V24		15	16.05		V
$V_{TH+(V24)}$	High-level V24-monitor threshold voltage				16.8	18	V
$V_{HYS(V24)}$	V24-monitor hysteresis				0.75		V
R_{IP}	Input resistance	IP0–IP7	3 V < V_{IPX} < 6 V, $R_{IN} = 1.2 \text{ k}\Omega \pm 5\%$, $R_{LIM} = 25 \text{ k}\Omega$	1.4	1.83	2.3	k Ω
I_{IP-LIM}	Input current limit				10 V < V_{IPX} < 30 V, $R_{LIM} = 25 \text{ k}\Omega$	3.15	3.6
V_{OL}	Logic low-level output voltage	SOP, CHOK	$I_{OL} = 20 \mu\text{A}$			0.4	V
V_{OH}	Logic high-level output voltage			$I_{OH} = -20 \mu\text{A}$	4		V
I_{IL}	Logic input leakage current	DB0, DB1, SIP, LD, CE, CLK		-50		50	μA
I_{RE-on}	RE on-state current	RE0–RE7	$R_{LIM} = 25 \text{ k}\Omega$, $RE_X = \text{FGND}$	2.8	3.15	3.5	mA
$I_{CC(V24)}$	Supply current	V24	IP0 to IP7 = V24, 5VOP = open, $RE_X = \text{FGND}$, All logic inputs open			8.7	mA
$V_{O(5V)}$	Linear regulator output voltage	5VOP	18 V < V_{24} < 30 V, no load	4.5	5	5.5	V
			18 V < V_{24} < 30 V, $I_L = 50 \text{ mA}$	4.5	5	5.5	
$I_{LIM(5V)}$	Linear regulator output current limit				115		mA
$\Delta V_5/\Delta V_{24}$	Line regulation	5VOP, V24	18 V < V_{24} < 30 V, $I_L = 5 \text{ mA}$			2	mV/V
t_{DB}	Debounce times of input channels	IP0–IP7	DB0 = open, DB1 = FGND		0		ms
			DB0 = FGND, DB1 = open		1		
			DB0 = DB1 = open		3		
t_{DB-HL}	Voltage monitor debounce time after V24 < 15 V (CHOK turns low)	V24, CHOK			1		ms
t_{DB-LH}	Voltage monitor debounce time after V24 > 18 V (CHOK turns high)				6		ms
T_{OVER}	Over-temperature indication				150		$^{\circ}\text{C}$
T_{SHDN}	Shutdown temperature				170		$^{\circ}\text{C}$

TIMING REQUIREMENTS

over operating free-air temperature range (unless otherwise noted)

SYMBOL	PARAMETER	MIN	TYP	MAX	UNIT
t_{W1}	CLK pulse width See Figure 6	4			ns
t_{W2}	\overline{LD} pulse width See Figure 4	6			ns
t_{SU1}	SIP to CLK setup time See Figure 7	4			ns
t_{H1}	SIP to CLK hold time See Figure 7	2			ns
t_{SU2}	Falling edge to rising edge (\overline{CE} to CLK) setup time See Figure 8	4			ns
t_{REC}	\overline{LD} to CLK recovery time See Figure 5	2			ns
f_{CLK}	Clock pulse frequency See Figure 6	DC		100	MHz

SWITCHING CHARACTERISTICS

over operating free-air temperature range (unless otherwise noted)

SYMBOL	PARAMETER	TEST CONDITIONS	MIN	TYP	MAX	UNIT
t_{PLH1}, t_{PHL1}	CLK to SOP $C_L = 15$ pF, see Figure 6				10	ns
t_{PLH2}, t_{PHL2}	\overline{LD} to SOP $C_L = 15$ pF, see Figure 4				14	ns
t_r, t_f	Rise and fall times $C_L = 15$ pF, see Figure 6				5	ns

INPUT CHARACTERISTICS

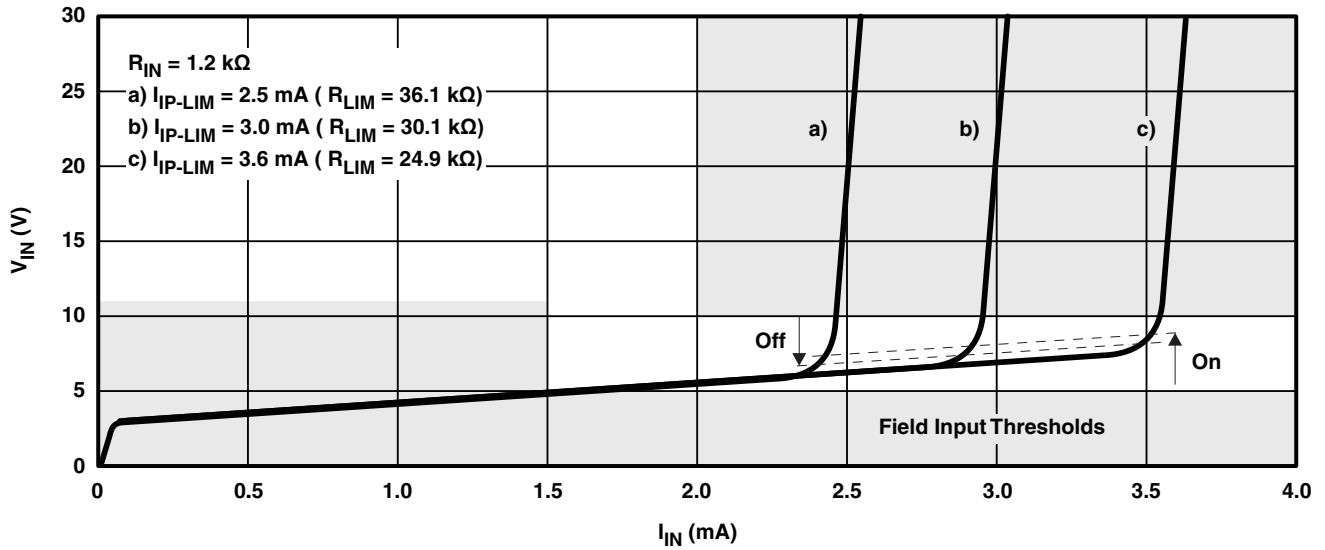

Figure 1. Typical Input Characteristics

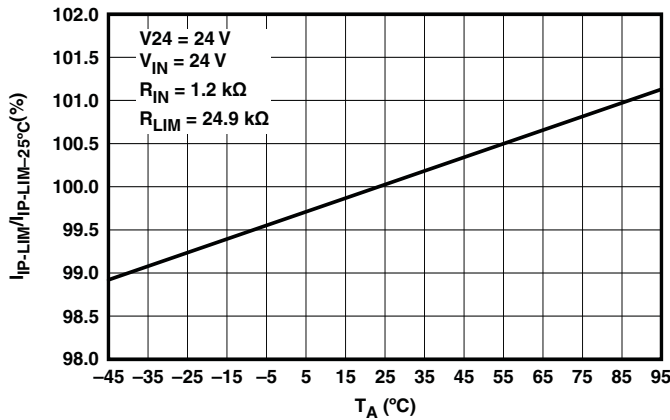

Figure 2. Typical Current Limiter Variation vs Ambient Temperature

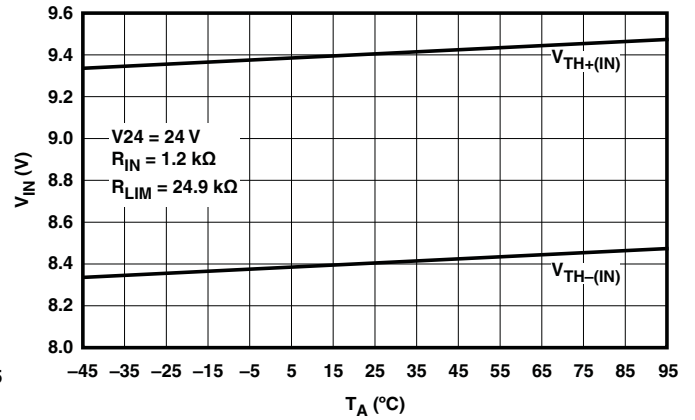

Figure 3. Typical Limiter Threshold Voltage Variation vs Ambient Temperature

PARAMETER MEASUREMENT INFORMATION

Waveforms

For the complete serial interface timing, refer to [Figure 21](#).

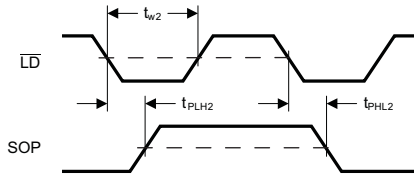

Figure 4. Parallel – Load Mode

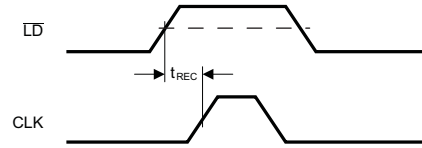

Figure 5. Serial – Shift Mode

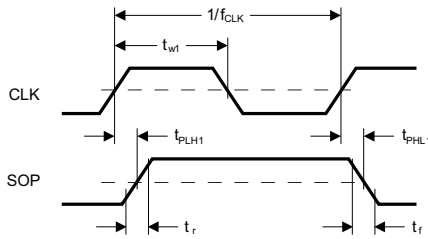

Figure 6. Serial – Shift Mode

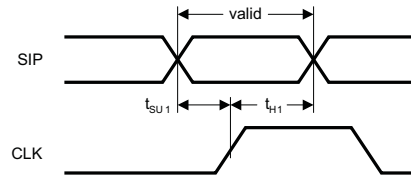

Figure 7. Serial – Shift Mode

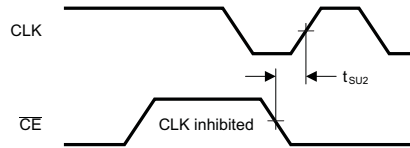

Figure 8. Serial – Shift Clock Inhibit Mode

VOLTAGE REGULATOR PERFORMANCE CHARACTERISTICS

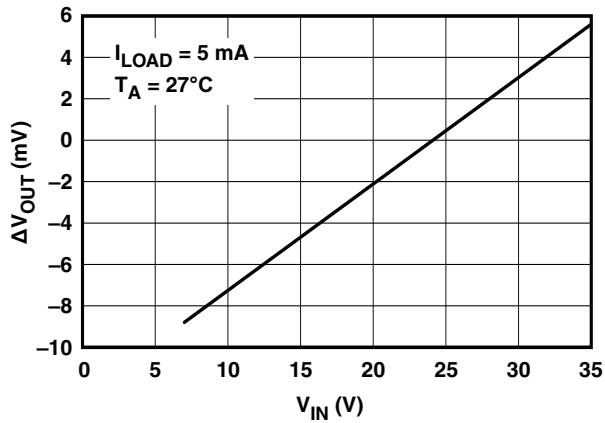

Figure 9. Line Regulation

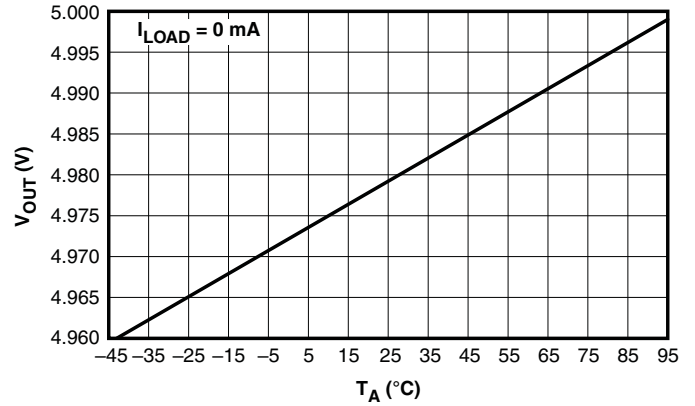

Figure 10. Output Voltage vs Ambient Temperature

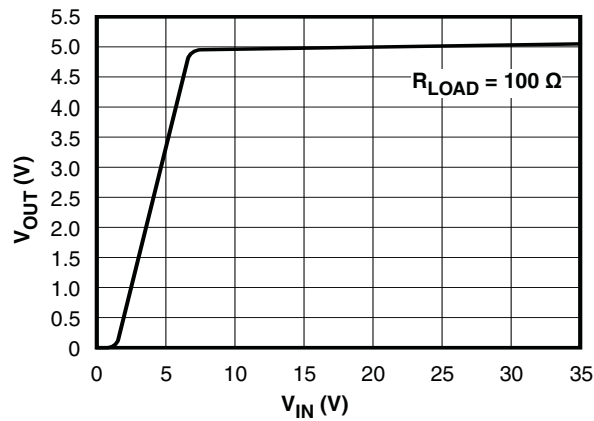

Figure 11. Output Voltage vs Input Voltage

SIGNAL CONVENTIONS

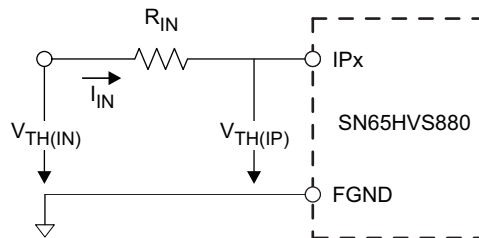

Figure 12. On/Off Threshold Voltage Measurements

DEVICE INFORMATION

Digital Inputs

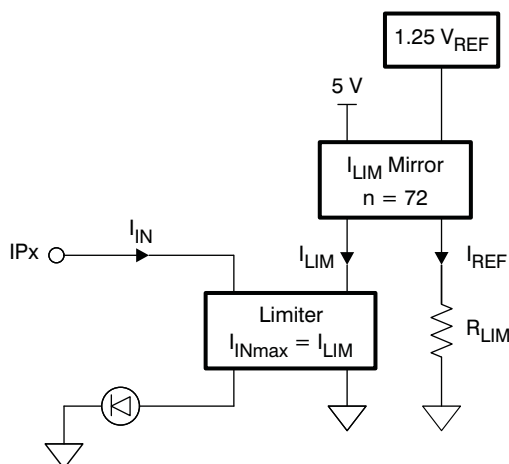

Figure 13. Digital Input Stage

Each digital input operates as a controlled current sink limiting the input current to a maximum value of I_{LIM} . The current limit is derived from the reference current via $I_{LIM} = n \times I_{REF}$, and I_{REF} is determined by $I_{REF} = V_{REF}/R_{LIM}$. Thus, changing the current limit requires the change of R_{LIM} to a different value via: $R_{LIM} = n \times V_{REF}/I_{LIM}$.

Inserting the actual values for n and V_{REF} gives: $R_{LIM} = 90 \text{ V} / I_{LIM}$.

While the device is specified for a current limit of **3.6 mA**, (via $R_{LIM} = 25 \text{ k}\Omega$), it is easy to lower the current limit to further reduce the power consumption. For example, for a current limit of **2.5 mA** simply calculate:

$$R_{LIM} = \frac{90 \text{ V}}{I_{LIM}} = \frac{90 \text{ V}}{2.5 \text{ mA}} = 36 \text{ k}\Omega$$

Debounce Filter

The HVS880 applies a simple analog/digital filtering technique to remove unintended signal transitions due to contact bounce or other mechanical effects. Any new input (either low or high) must be present for the duration of the selected debounce time to be latched into the shift register as a valid state.

The logic signal levels at the control inputs, DB0 and DB1 of the internal Debounce-Select logic determine the different debounce times listed in the following truth table.

Table 1. Debounce Times

DB1	DB0	FUNCTION
Open	Open	3 ms delay
Open	FGND	1 ms delay
FGND	Open	0 ms delay (Filter bypassed)
FGND	FGND	Reserved

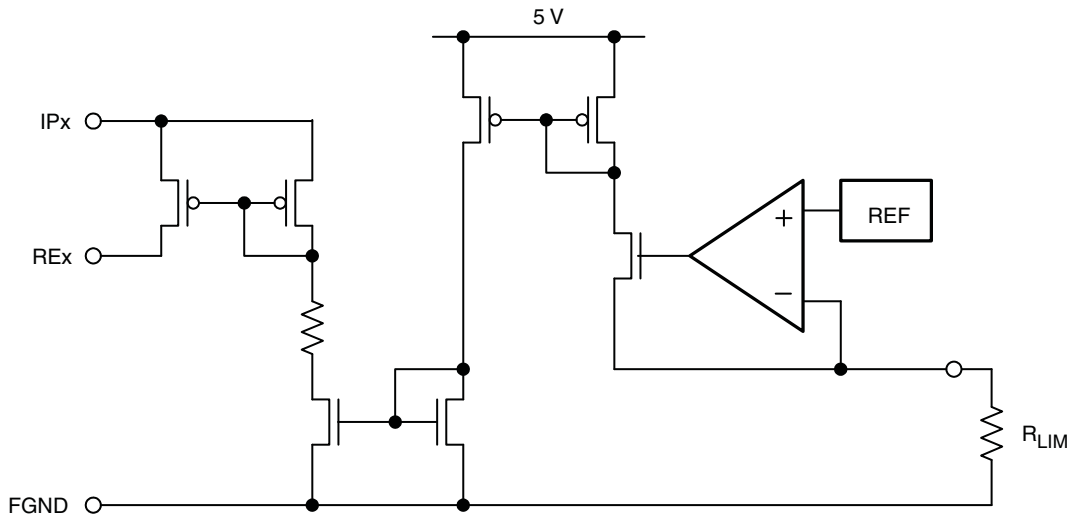

Figure 14. Equivalent Input Diagram

Shift Register

The conversion from parallel input to serial output data is performed by an eight-channel, parallel-in serial-out shift register. Parallel-in access is provided by the internal inputs, PIP0–PIP7, that are enabled by a low level at the load input ($\overline{\text{LD}}$). When clocked, the latched input data shift towards the serial output (SOP). The shift register also provides a clock-enable function.

Clocking is accomplished by a low-to-high transition of the clock ($\overline{\text{CLK}}$) input while $\overline{\text{LD}}$ is held high and the clock enable ($\overline{\text{CE}}$) input is held low. Parallel loading is inhibited when $\overline{\text{LD}}$ is held high. The parallel inputs to the register are enabled while $\overline{\text{LD}}$ is low independently of the levels of the $\overline{\text{CLK}}$, $\overline{\text{CE}}$, or serial (SIP) inputs.

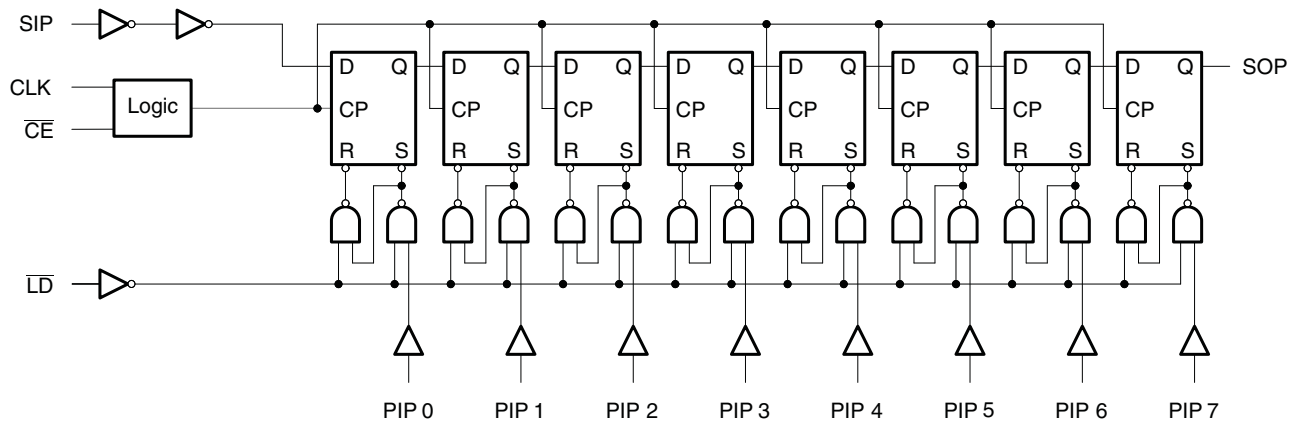

Figure 15. Shift Register Logic Structure

Table 2. Function Table

INPUTS			FUNCTION
$\overline{\text{LD}}$	CLK	$\overline{\text{CE}}$	
L	X	X	Parallel load
H	X	H	No change
H	↑	L	Shift ⁽¹⁾

(1) Shift = content of each internal register shifts towards serial outputs. Data at SIP is shifted into first register.

Voltage Regulator

The on-chip linear voltage regulator provides a 5 V supply to the internal- and external circuitry, such as digital isolators, with an output drive capability of 50 mA and a typical current limit of 115 mA. The regulator accepts input voltages from 30 V down to 10 V. Because the regulator output is intended to supply external digital isolator circuits proper output voltage decoupling is required. For best results connect a 1 μF and a 0.1 μF ceramic capacitor as close as possible to the 5VOP-output. For longer traces between the SN65HVS880 and isolators of the ISO72xx family use additional 0.1 μF and 10 pF capacitors next to the isolator supply pins. Make sure, however, that the total load capacitance does not exceed 4.7 μF .

For good stability the voltage regulator requires a minimum load current, $I_{L\text{-MIN}}$. Ensure that under any operating condition the ratio of the minimum load current in mA to the total load capacitance in μF is larger than 1:

$$\frac{I_{L\text{-MIN}}}{C_L} > \frac{1 \text{ mA}}{1 \mu\text{F}}$$

Supply Voltage Monitor

The integrated supply voltage monitor senses the supply voltage of the SN65HVS880 at the V24-pin. If this voltage drops below 15 V but stays within the regulator's operating range, i.e., $15 \text{ V} > V24 > 10 \text{ V}$, the output CHOK goes low 1 ms later. When the supply voltage returns to 24 V, the CHOK output turns logic high after 6 ms. Should the supply voltage drop below 10 V, the device ceases operation. Upon the supply returning to above 18 V, the CHOK output turns high again after 6 ms.

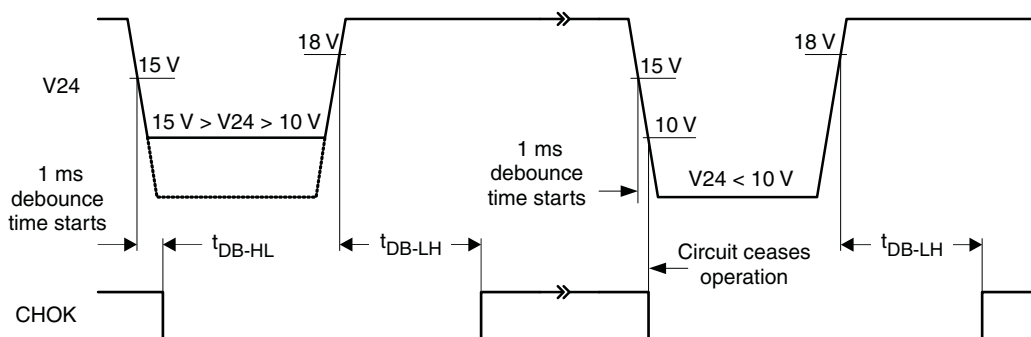

Figure 16. CHOK Output Timing as a Function of Supply Voltage Drop at V24

Temperature Sensor

An on-chip temperature sensor monitors the device temperature and signals a fault condition if the device becomes too hot. A first trip point exists at 150°C. If the junction temperature exceeds this trip point, the sensor output, being active low, presents a low to the input of the AND gate forcing the CHOK output to go low. If the junction temperature continues to rise, passing a second trip point at 170°C, all device outputs assume tri-state.

Chip Okay (CHOK) Output

The CHOK output is the Boolean AND-function of the two, active-low fault conditions: temperature failure and supply failure. As such CHOK is a device health indicator, assuming logic high in the absence of any fault condition. If either one of the two or both fault conditions occur, CHOK becomes logic low.

A special condition occurs, however, when the chip temperature exceeds the second temperature trip point due to an output short. Then the CHOK output buffer becomes tri-state, thus separating the buffer from the external circuitry. An internal 100 k Ω pulldown resistor, connecting the CHOK-pin to ground, is used as a “cooling down” resistor, which continues to provide a logic low level to the external circuitry.

APPLICATION INFORMATION

System-Level EMC

The SN65HVS880 must operate reliably in harsh industrial environments. At a system level, the device is tested according to several international electromagnetic compatibility (EMC) standards.

In addition to the device internal ESD structures, external protection circuitry, such as the one in Figure 17, is needed to absorb as much energy from burst- and surge-transients as possible.

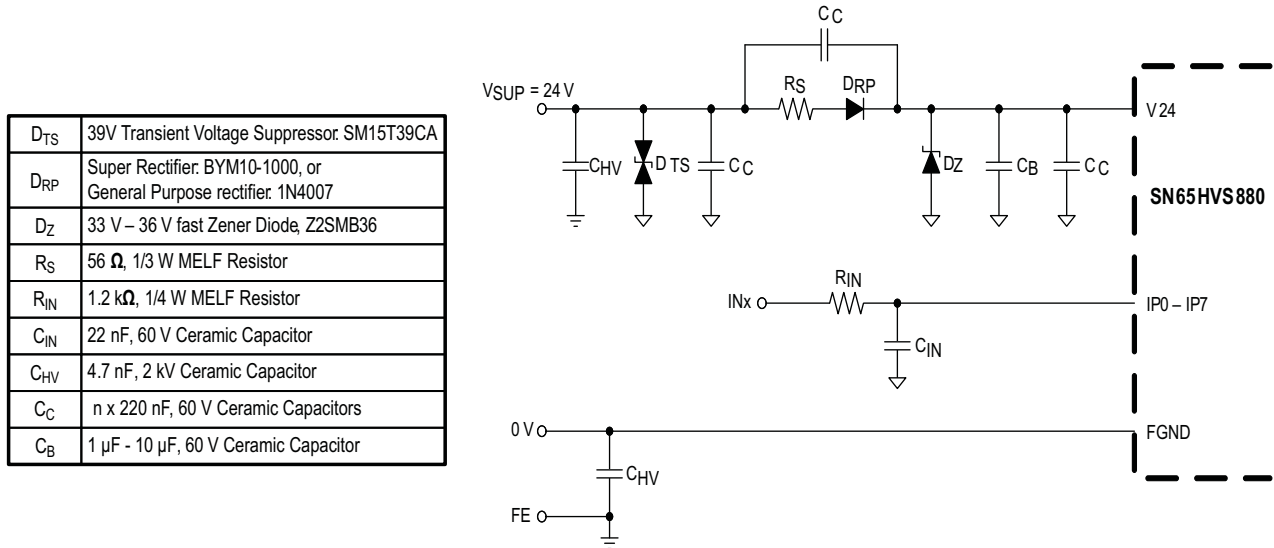

Figure 17. Typical EMC Protection Circuitry for Supply and Signal Inputs

Input Channel Switching Characteristics

The input stage of the HVS880 is so designed, that for an input resistor R_{IN} = 1.2 kΩ the trip point for signalling an ON-condition is at 9.4 V at 3.6 mA. This trip point satisfies the switching requirements of IEC61131-2 Type 1 and Type 3 switches.

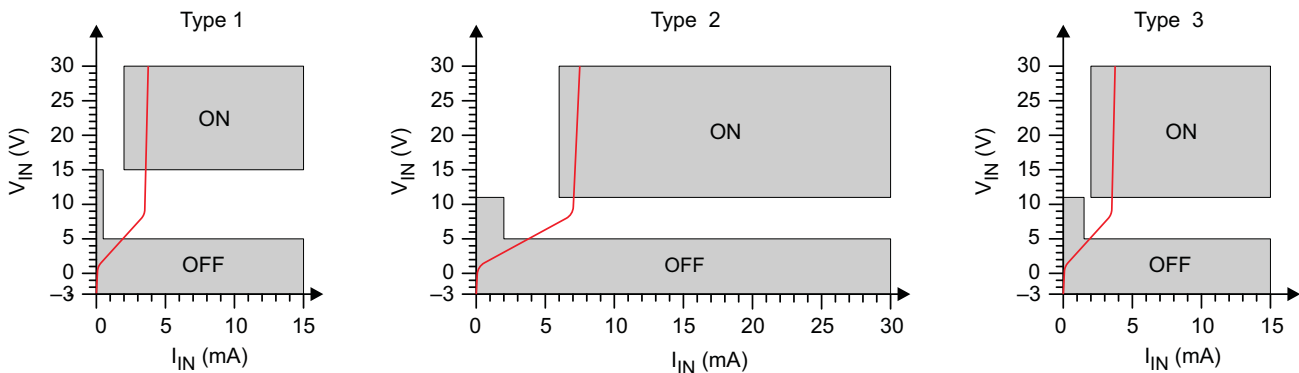

Figure 18. Switching Characteristics for IEC61131-2 Type 1, 2, and 3 Proximity Switches

For a Type 2 switch application, two inputs are connected in parallel. The current limiters then add to a total maximum current of 7.2 mA. While the return-path (RE-pin), of one input might be used to drive an indicator LED, the RE-pin of the other input channel should be connected to ground (FGND).

Paralleling input channels reduces the number of available input channels from an octal Type 1 or Type 3 input to a quad Type 2 input device. Note, that in this configuration output data of an input channel is represented by two shift register bits.

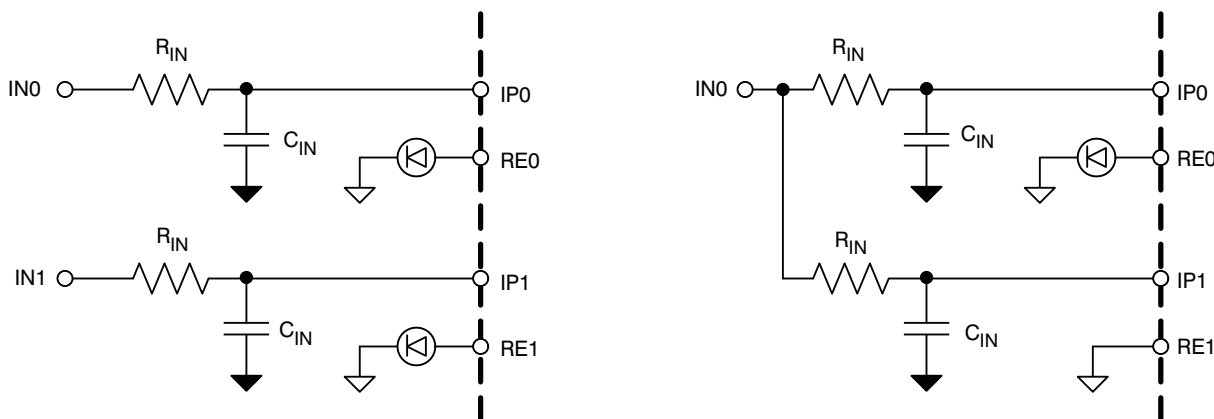

Figure 19. Paralleling Two Type 1 or Type 3 Inputs Into One Type 2 Input

Digital Interface Timing

The digital interface of the SN65HVS880 is SPI compatible and interfaces, isolated or non-isolated, to a wide variety of standard micro controllers.

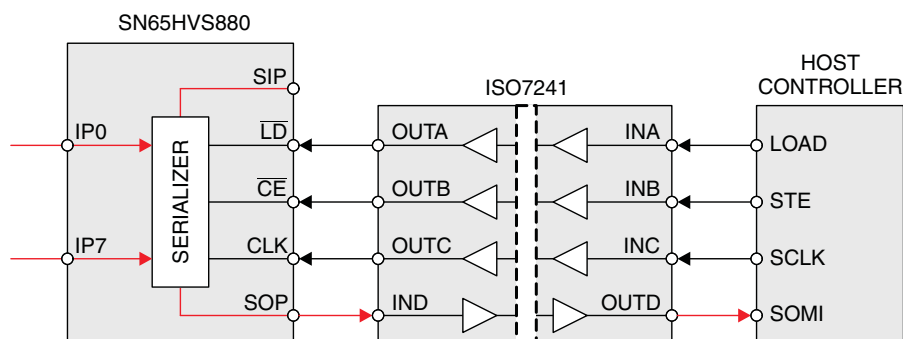

Figure 20. Simple Isolation of the Shift Register Interface

Upon a low-level at the load input, \overline{LD} , the information of the field inputs, IP0 to IP7 is latched into the shift register. Taking \overline{LD} high again blocks the parallel inputs of the shift register from the field inputs. A low-level at the clock-enable input, \overline{CE} , enables the clock signal, CLK, to serially shift the data to the serial output, SOP. Data is clocked at the rising edge of CLK. Thus after eight consecutive clock cycles all field input data have been clocked out of the shift register and the information of the serial input, SIP, appears at the serial output, SOP.

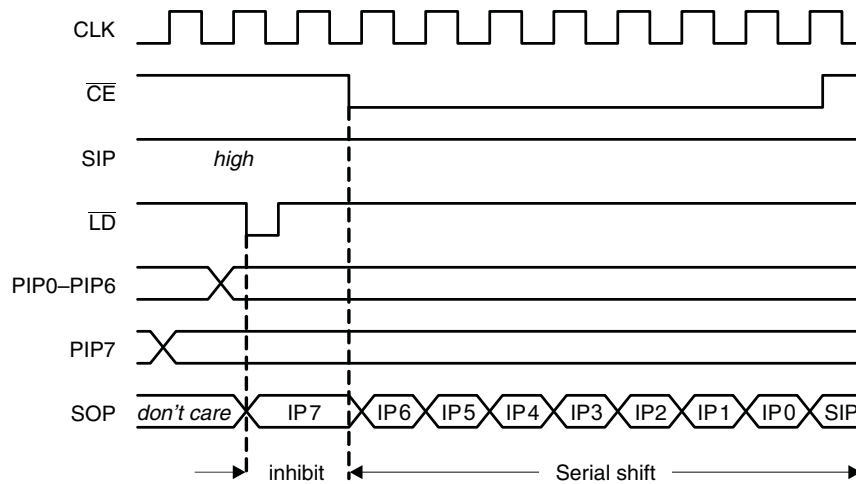

Figure 21. Interface Timing for Parallel-Load and Serial-Shift Operation of the Shift Register

Cascading for High Channel Count Input Modules

Designing high-channel count modules require cascading multiple SN65HVS880 devices. Simply connect the serial output (SOP) of a leading device with the serial input (SIP) of a following device without changing the processor interface.

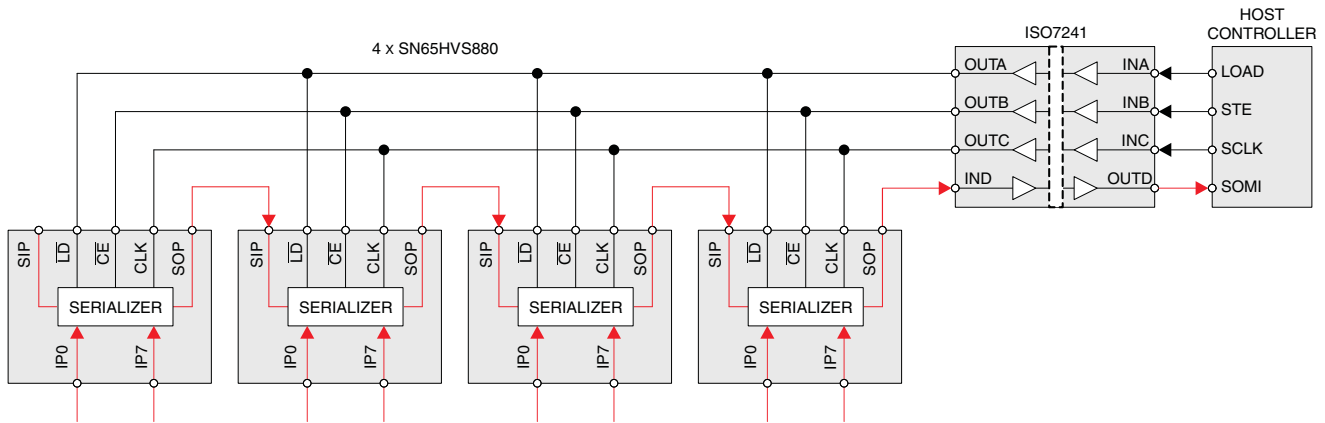

Figure 22. Cascading Four SN65HVS880 for a 32-Channel Input Module

Typical Digital Input Module Application

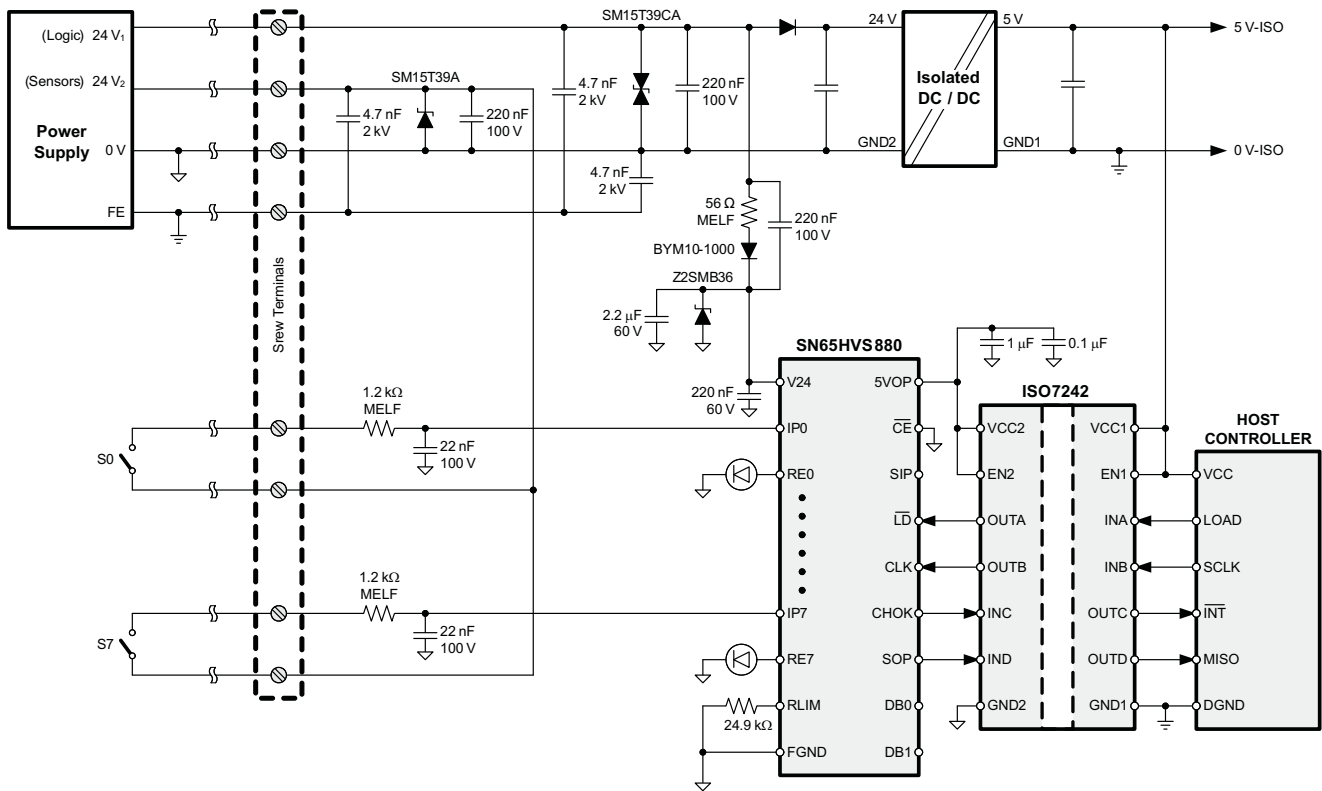

Figure 23. Typical Digital Input Module Application

PACKAGING INFORMATION

Orderable Device	Status (1)	Package Type	Package Drawing	Pins	Package Qty	Eco Plan (2)	Lead finish/ Ball material (6)	MSL Peak Temp (3)	Op Temp (°C)	Device Marking (4/5)	Samples
SN65HVS880PWPR	ACTIVE	HTSSOP	PWP	28	2000	RoHS & Green	NIPDAU	Level-2-260C-1 YEAR	-40 to 85	HVS880	Samples

(1) The marketing status values are defined as follows:

ACTIVE: Product device recommended for new designs.

LIFEBUY: TI has announced that the device will be discontinued, and a lifetime-buy period is in effect.

NRND: Not recommended for new designs. Device is in production to support existing customers, but TI does not recommend using this part in a new design.

PREVIEW: Device has been announced but is not in production. Samples may or may not be available.

OBSELETE: TI has discontinued the production of the device.

(2) **RoHS:** TI defines "RoHS" to mean semiconductor products that are compliant with the current EU RoHS requirements for all 10 RoHS substances, including the requirement that RoHS substance do not exceed 0.1% by weight in homogeneous materials. Where designed to be soldered at high temperatures, "RoHS" products are suitable for use in specified lead-free processes. TI may reference these types of products as "Pb-Free".

RoHS Exempt: TI defines "RoHS Exempt" to mean products that contain lead but are compliant with EU RoHS pursuant to a specific EU RoHS exemption.

Green: TI defines "Green" to mean the content of Chlorine (Cl) and Bromine (Br) based flame retardants meet JS709B low halogen requirements of <=1000ppm threshold. Antimony trioxide based flame retardants must also meet the <=1000ppm threshold requirement.

(3) MSL, Peak Temp. - The Moisture Sensitivity Level rating according to the JEDEC industry standard classifications, and peak solder temperature.

(4) There may be additional marking, which relates to the logo, the lot trace code information, or the environmental category on the device.

(5) Multiple Device Markings will be inside parentheses. Only one Device Marking contained in parentheses and separated by a "~" will appear on a device. If a line is indented then it is a continuation of the previous line and the two combined represent the entire Device Marking for that device.

(6) Lead finish/Ball material - Orderable Devices may have multiple material finish options. Finish options are separated by a vertical ruled line. Lead finish/Ball material values may wrap to two lines if the finish value exceeds the maximum column width.

Important Information and Disclaimer:The information provided on this page represents TI's knowledge and belief as of the date that it is provided. TI bases its knowledge and belief on information provided by third parties, and makes no representation or warranty as to the accuracy of such information. Efforts are underway to better integrate information from third parties. TI has taken and continues to take reasonable steps to provide representative and accurate information but may not have conducted destructive testing or chemical analysis on incoming materials and chemicals. TI and TI suppliers consider certain information to be proprietary, and thus CAS numbers and other limited information may not be available for release.

In no event shall TI's liability arising out of such information exceed the total purchase price of the TI part(s) at issue in this document sold by TI to Customer on an annual basis.

TAPE AND REEL INFORMATION

QUADRANT ASSIGNMENTS FOR PIN 1 ORIENTATION IN TAPE

*All dimensions are nominal

Device	Package Type	Package Drawing	Pins	SPQ	Reel Diameter (mm)	Reel Width W1 (mm)	A0 (mm)	B0 (mm)	K0 (mm)	P1 (mm)	W (mm)	Pin1 Quadrant
SN65HVS880PWPR	HTSSOP	PWP	28	2000	330.0	16.4	6.9	10.2	1.8	12.0	16.0	Q1

TAPE AND REEL BOX DIMENSIONS

*All dimensions are nominal

Device	Package Type	Package Drawing	Pins	SPQ	Length (mm)	Width (mm)	Height (mm)
SN65HVS880PWPR	HTSSOP	PWP	28	2000	350.0	350.0	43.0

GENERIC PACKAGE VIEW

PWP 28

PowerPAD™ TSSOP - 1.2 mm max height

4.4 x 9.7, 0.65 mm pitch

SMALL OUTLINE PACKAGE

This image is a representation of the package family, actual package may vary.
Refer to the product data sheet for package details.

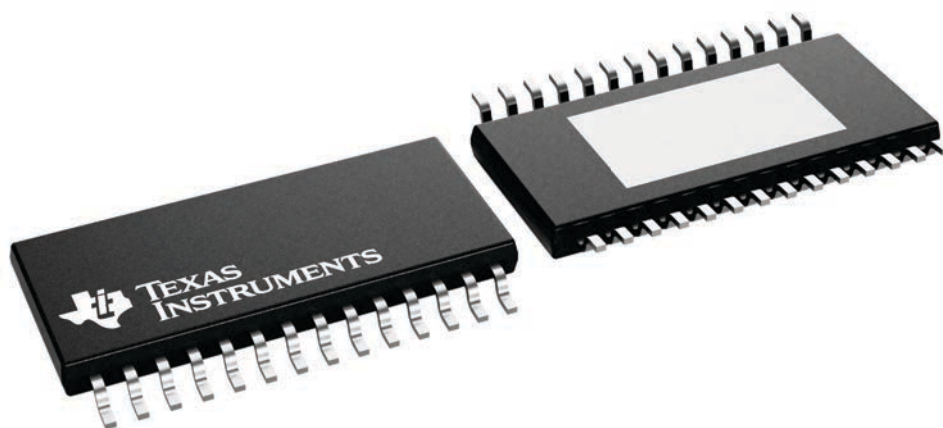

4224765/B

MECHANICAL DATA

PWP (R-PDSO-G28)

PowerPAD™ PLASTIC SMALL OUTLINE

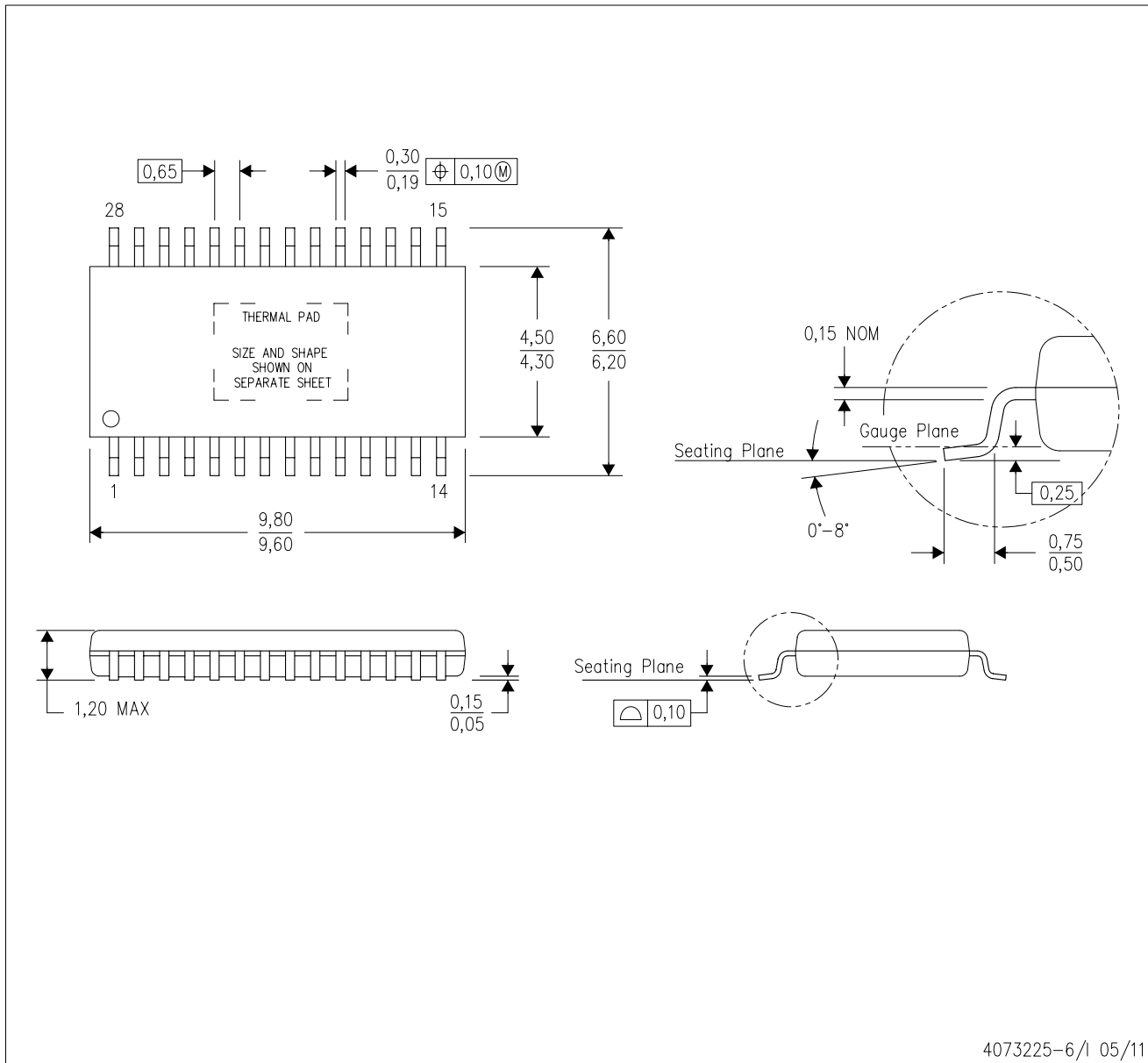

- NOTES:
- All linear dimensions are in millimeters.
 - This drawing is subject to change without notice.
 - Body dimensions do not include mold flash or protrusions. Mold flash and protrusion shall not exceed 0.15 per side.
 - This package is designed to be soldered to a thermal pad on the board. Refer to Technical Brief, PowerPad Thermally Enhanced Package, Texas Instruments Literature No. SLMA002 for information regarding recommended board layout. This document is available at www.ti.com <<http://www.ti.com>>.
 - See the additional figure in the Product Data Sheet for details regarding the exposed thermal pad features and dimensions.
 - Falls within JEDEC MO-153

PowerPAD is a trademark of Texas Instruments.

THERMAL PAD MECHANICAL DATA

PWP (R-PDSO-G28) PowerPAD™ SMALL PLASTIC OUTLINE

THERMAL INFORMATION

This PowerPAD™ package incorporates an exposed thermal pad that is designed to be attached to a printed circuit board (PCB). The thermal pad must be soldered directly to the PCB. After soldering, the PCB can be used as a heatsink. In addition, through the use of thermal vias, the thermal pad can be attached directly to the appropriate copper plane shown in the electrical schematic for the device, or alternatively, can be attached to a special heatsink structure designed into the PCB. This design optimizes the heat transfer from the integrated circuit (IC).

For additional information on the PowerPAD package and how to take advantage of its heat dissipating abilities, refer to Technical Brief, PowerPAD Thermally Enhanced Package, Texas Instruments Literature No. SLMA002 and Application Brief, PowerPAD Made Easy, Texas Instruments Literature No. SLMA004. Both documents are available at www.ti.com.

The exposed thermal pad dimensions for this package are shown in the following illustration.

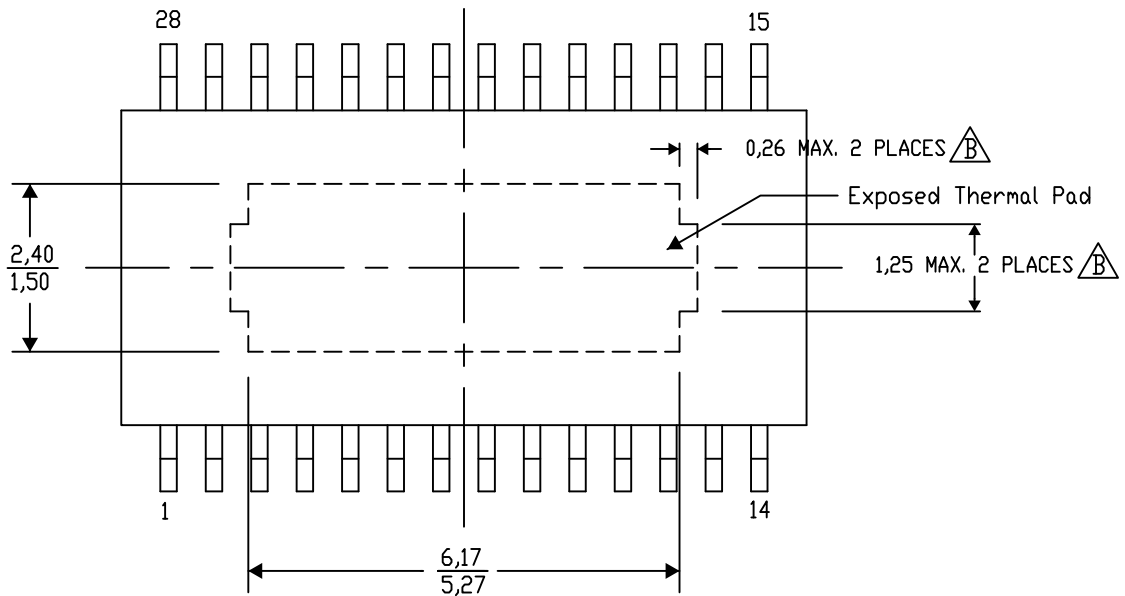

Top View

Exposed Thermal Pad Dimensions

4206332-33/AO 01/16

NOTE: A. All linear dimensions are in millimeters

$\triangle B$. Exposed tie strap features may not be present.

PowerPAD is a trademark of Texas Instruments

PWP (R-PDSO-G28)

PowerPAD™ PLASTIC SMALL OUTLINE

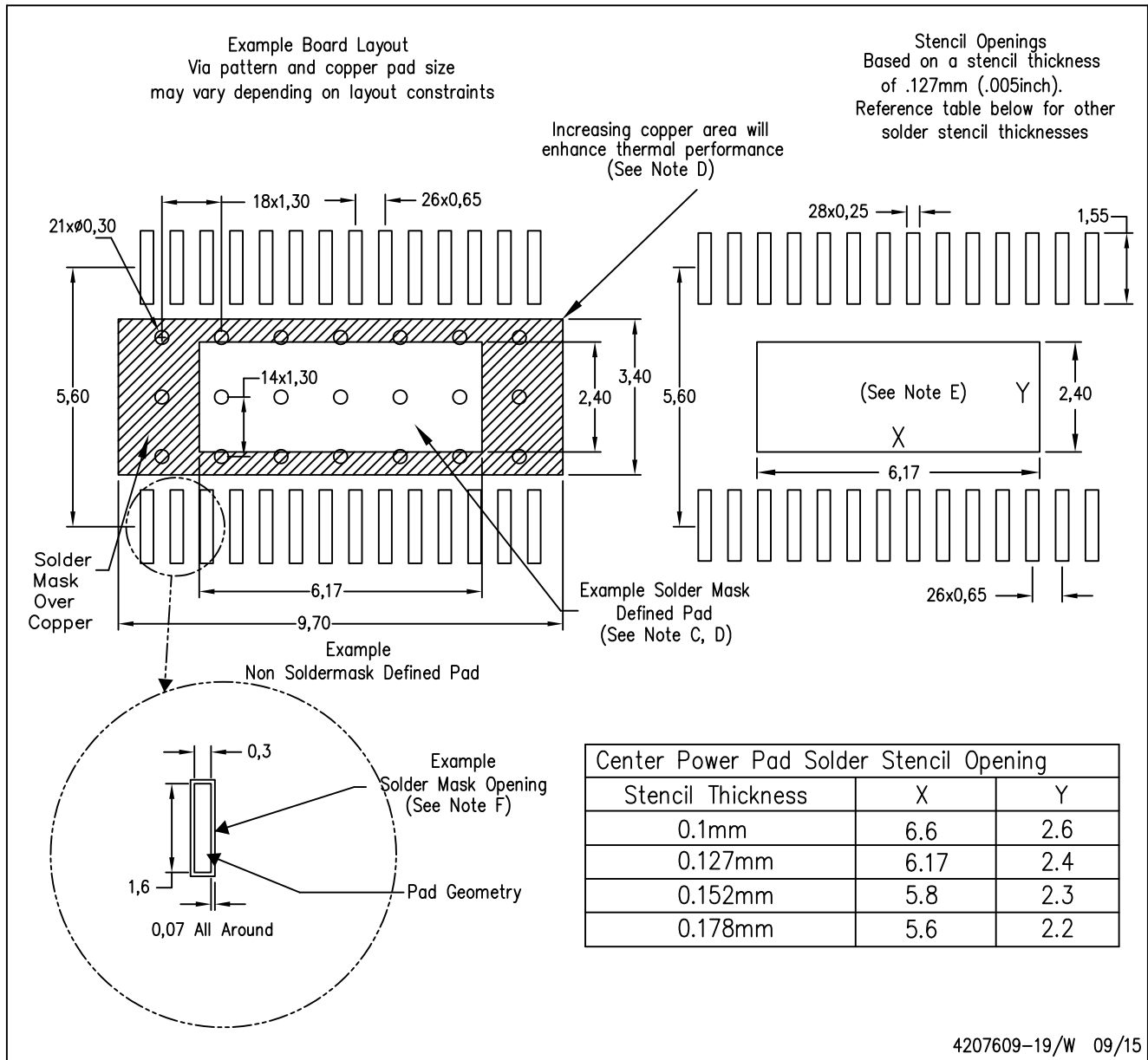

NOTES:

- A. All linear dimensions are in millimeters.
- B. This drawing is subject to change without notice.
- C. Customers should place a note on the circuit board fabrication drawing not to alter the center solder mask defined pad.
- D. This package is designed to be soldered to a thermal pad on the board. Refer to Technical Brief, PowerPad Thermally Enhanced Package, Texas Instruments Literature No. SLMA002, SLMA004, and also the Product Data Sheets.
- E. For specific thermal information, via requirements, and recommended board layout. These documents are available at www.ti.com <<http://www.ti.com>>. Publication IPC-7351 is recommended for alternate designs. Laser cutting apertures with trapezoidal walls and also rounding corners will offer better paste release. Customers should contact their board assembly site for stencil design recommendations. Example stencil design based on a 50% volumetric metal load solder paste. Refer to IPC-7525 for other stencil
- F. Customers should contact their board fabrication site for solder mask tolerances between and around signal pads.

IMPORTANT NOTICE AND DISCLAIMER

TI PROVIDES TECHNICAL AND RELIABILITY DATA (INCLUDING DATA SHEETS), DESIGN RESOURCES (INCLUDING REFERENCE DESIGNS), APPLICATION OR OTHER DESIGN ADVICE, WEB TOOLS, SAFETY INFORMATION, AND OTHER RESOURCES "AS IS" AND WITH ALL FAULTS, AND DISCLAIMS ALL WARRANTIES, EXPRESS AND IMPLIED, INCLUDING WITHOUT LIMITATION ANY IMPLIED WARRANTIES OF MERCHANTABILITY, FITNESS FOR A PARTICULAR PURPOSE OR NON-INFRINGEMENT OF THIRD PARTY INTELLECTUAL PROPERTY RIGHTS.

These resources are intended for skilled developers designing with TI products. You are solely responsible for (1) selecting the appropriate TI products for your application, (2) designing, validating and testing your application, and (3) ensuring your application meets applicable standards, and any other safety, security, regulatory or other requirements.

These resources are subject to change without notice. TI grants you permission to use these resources only for development of an application that uses the TI products described in the resource. Other reproduction and display of these resources is prohibited. No license is granted to any other TI intellectual property right or to any third party intellectual property right. TI disclaims responsibility for, and you will fully indemnify TI and its representatives against, any claims, damages, costs, losses, and liabilities arising out of your use of these resources.

TI's products are provided subject to [TI's Terms of Sale](#) or other applicable terms available either on [ti.com](https://www.ti.com) or provided in conjunction with such TI products. TI's provision of these resources does not expand or otherwise alter TI's applicable warranties or warranty disclaimers for TI products.

TI objects to and rejects any additional or different terms you may have proposed.

Mailing Address: Texas Instruments, Post Office Box 655303, Dallas, Texas 75265
Copyright © 2024, Texas Instruments Incorporated