

SN65LBC175A, SN75LBC175A Quadruple RS-485 Differential Line Receivers

1 Features

- Designed for TIA/EIA-485, TIA/EIA-422, and ISO 8482 applications
- Signaling rate exceeding 50 Mbps
- Fail-safe in bus short-circuit, open-circuit, and idle-bus conditions
- ESD protection on bus inputs 6 kV
- Common-mode bus input range -7 V to 12 V
- Propagation delay times $<16\text{ ns}$
- Low standby power consumption $<20\text{ }\mu\text{A}$
- Pin-compatible upgrade for MC3486, DS96F175, LTC489, and SN75175

2 Applications

- [Factory automation](#)
- ATM and cash counters
- [Smart grid](#)
- [AC and servo motor drives](#)

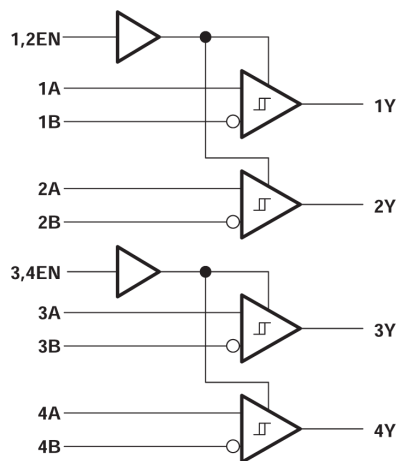

Logic Diagram¹

3 Description

The SN65LBC175A and SN75LBC175A are quadruple differential line receivers with 3-state outputs, designed for TIA/EIA-485 (RS-485), TIA/EIA-422 (RS-422), and ISO 8482 (Euro RS-485) applications.

These devices are optimized for balanced multipoint bus communication at data rates up to and exceeding 50 million bits per second. The transmission media may be twisted-pair cables, printed-circuit board traces, or backplanes. The ultimate rate and distance of data transfer is dependent upon the attenuation characteristics of the media and the noise coupling to the environment.

Each receiver operates over a wide range of positive and negative common-mode input voltages, and features ESD protection to 6 kV, making it suitable for high-speed multipoint data transmission applications in harsh environments. These devices are designed using LinBiCMOS™, facilitating low power consumption and inherent robustness.

Two EN inputs provide pair-wise enable control, or these can be tied together externally to enable all four drivers with the same signal.

The SN75LBC175A is characterized for operation over the temperature range of 0°C to 70°C . The SN65LBC175A is characterized over the temperature range from -40°C to 85°C .

Package Information

PART NUMBER	PACKAGE ⁽¹⁾	PACKAGE SIZE ⁽²⁾
SN65LBC175A	SOIC (D, 16)	9.9 mm × 6 mm
SN75LBC175A	PDIP (N, 16)	19.3 mm × 9.4 mm

(1) For more information, see [Section 11](#).

(2) The package size (length × width) is a nominal value and includes pins, where applicable.

¹ The signaling rate of a line is the number of voltage transitions that are made per second expressed in the units bps (bits per second).



Table of Contents

1 Features	1	7 Detailed Description	11
2 Applications	1	7.1 Device Functional Modes.....	11
3 Description	1	8 Application and Implementation	12
4 Pin Configuration and Functions	3	8.1 Typical Application.....	12
5 Specifications	4	9 Device and Documentation Support	14
5.1 Absolute Maximum Ratings.....	4	9.1 Receiving Notification of Documentation Updates....	14
5.2 ESD Ratings.....	4	9.2 Support Resources.....	14
5.3 Dissipation Rating Table.....	4	9.3 Trademarks.....	14
5.4 Thermal Information.....	4	9.4 Electrostatic Discharge Caution.....	14
5.5 Recommended Operating Conditions.....	5	9.5 Glossary.....	14
5.6 Electrical Characteristics.....	5	10 Revision History	14
5.7 Switching Characteristics.....	6	11 Mechanical, Packaging, and Orderable	
5.8 Typical Characteristics.....	7	Information	14
6 Parameter Measurement Information	9		

4 Pin Configuration and Functions

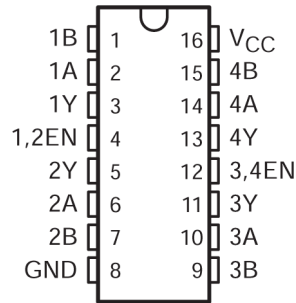

**Figure 4-1. SN65LBC175A (Marked as 65LBC175A)
SN75LBC175A (Marked as 75LBC175A)
D or N Package (Top View)**

Table 4-1. Pin Functions

PIN		TYPE ⁽¹⁾	DESCRIPTION
NAME	NO.		
1B	1	I	Channel 1 Inverting Differential Input
1A	2	I	Channel 1 Non-Inverting Differential Input
1Y	3	O	Channel 1 Output
1,2 EN	4	I	Channel 1 and 2 Active High Enable
2Y	5	O	Channel 2 Output
2A	6	I	Channel 2 Non-Inverting Differential Input
2B	7	I	Channel 2 Inverting Differential Input
GND	8	GND	Device Ground
3B	9	I	Channel 3 Inverting Differential Input
3A	10	I	Channel 3 Non-Inverting Differential Input
3Y	11	O	Channel 3 Output
3,4 EN	12	I	Channel 3 and 4 Active High Enable
4Y	13	O	Channel 4 Output
4A	14	I	Channel 4 Non-Inverting Differential Input
4B	15	I	Channel 4 Inverting Differential Input
V _{CC}	16	POW	Device Supply

(1) Signal Types: I = Input, O = Output, I/O = Input or Output.

5 Specifications

5.1 Absolute Maximum Ratings

over operating free-air temperature range (unless otherwise noted)⁽¹⁾

			MIN	MAX	UNIT
V _{CC} (see ⁽²⁾)	Supply voltage range		-0.3	6	V
	Voltage range at any bus input (steady state)	A and B	-10	15	V
	Voltage range at any bus input	transient pulse through 100 Ω, see Figure 6-5	-30	30	V
V _I	Voltage input range at 1,2EN and 3,4EN		-0.5	V _{CC} + 0.5	V
I _O	Receiver output current		±10	mA	
	Electrostatic discharge:				
	Continuous power dissipation		See Power Dissipation Rating Table		

- (1) Stresses beyond those listed under “absolute maximum ratings” may cause permanent damage to the device. These are stress ratings only, and functional operation of the device at these or any other conditions beyond those indicated under “recommended operating conditions” is not implied. Exposure to absolute-maximum-rated conditions for extended periods may affect device reliability.
- (2) All voltage values, except differential I/O bus voltages, are with respect to GND, and are steady-state (unless otherwise specified).

5.2 ESD Ratings

			VALUE	UNIT
V _(ESD)	Electrostatic discharge	Human-body model (HBM), per ANSI/ESDA/JEDEC JS-001 ⁽¹⁾	A and B to GND ±6000	V
			All pins ±5000	
		Charged device model (CDM), per ANSI/ESDA/JEDEC JS-002 ⁽²⁾	All pins ±2000	

- (1) Tested in accordance with JEDEC Standard 22, Test Method A114-A.
- (2) Tested in accordance with JEDEC Standard 22, Test Method C101.

5.3 Dissipation Rating Table

PACKAGE	T _A ≤ 25°C POWER RATING	DERATING FACTOR ⁽¹⁾ ABOVE T _A = 25°C	T _A = 70°C POWER RATING	T _A = 85°C POWER RATING
D	1080 mW	8.7 mW/°C	690 mW	560 mW
N	1150 mW	9.2 mW/°C	736 mW	598 mW

- (1) This is the inverse of the junction-to-ambient thermal resistance when board-mounted and with no air flow.

5.4 Thermal Information

THERMAL METRIC ⁽¹⁾		SOIC (D)	PDIP (N)	UNIT
		16 Pins	16 Pins	
R _{θJA}	Junction-to-ambient thermal resistance	84.6	60.6	°C/W
R _{θJC(top)}	Junction-to-case (top) thermal resistance	43.5	48.1	°C/W
R _{θJB}	Junction-to-board thermal resistance	43.1	40.6	°C/W
ψ _{JT}	Junction-to-top characterization parameter	10.4	27.5	°C/W
ψ _{JB}	Junction-to-board characterization parameter	42.8	40.3	°C/W
R _{θJC(bot)}	Junction-to-case (bottom) thermal resistance	N/A	N/A	°C/W

- (1) For more information about traditional and new thermal metrics, see the [Semiconductor and IC package thermal metrics](#) application report.

5.5 Recommended Operating Conditions

		MIN	NOM	MAX	UNIT
Supply voltage, V_{CC}		4.75	5	5.25	V
Voltage at any bus terminal	A, B	-7		12	V
High-level input voltage, V_{IH}	EN	2		V_{CC}	V
Low-level input voltage, V_{IL}		0		0.8	mA
Output current	Y	-8		8	
Operating free-air temperature, T_A	SN75LBC175A	0		70	°C
	SN65LBC175A	-40		85	

5.6 Electrical Characteristics

over recommended operating conditions

PARAMETER		TEST CONDITIONS		MIN	TYP ⁽¹⁾	MAX	UNIT
V_{IT+}	Positive-going differential input voltage threshold	$-7\text{ V} \leq V_{CM} \leq 12\text{ V}$ ($V_{CM} = (V_A + V_B) / 2$)		-80		-10	mV
V_{IT-}	Negative-going differential input voltage threshold			-200	-120		
V_{HYS}	Hysteresis voltage ($V_{IT+} - V_{IT-}$)			-40			mV
V_{IK}	Input clamp voltage	$I_I = -18\text{ mA}$		-1.5	-0.8		V
V_{OH}	High-level output voltage	$V_{ID} = 200\text{ mV}$, $I_{OH} = -8\text{ mA}$	See Figure 6-1	2.7	4.8		V
V_{OL}	Low-level output voltage	$V_{ID} = -200\text{ mV}$, $I_{OL} = 8\text{ mA}$		0.2	0.4		
I_{OZ}	High-impedance-state output current	$V_O = 0\text{ V to } V_{CC}$		-1		1	μA
I_I	Line input current	Other input at 0 V, $V_{CC} = 0\text{ V or } 5\text{ V}$	$V_I = 12\text{ V}$			0.9	mA
			$V_I = -7\text{ V}$	-0.7			
I_{IH}	High-level input current	Enable inputs				100	μA
I_{IL}	Low-level input current					-100	μA
R_I	Input resistance	A, B		12			k Ω
I_{CC}	Supply current	$V_{ID} = 5\text{ V}$	1,2EN, 3,4EN at 0 V			20	mA
		No load	1,2EN, 3,4EN at V_{CC}	11		16	

(1) All typical values are at $V_{CC} = 5\text{ V}$ and 25°C .

5.7 Switching Characteristics

over recommended operating conditions

PARAMETER		TEST CONDITIONS	MIN	TYP ⁽¹⁾	MAX	UNIT	
t_r	output rise time			2	4	ns	
t_f	output fall time	$V_{ID} = -3\text{ V to }3\text{ V}$, See Figure 6-2		2	4	ns	
t_{PLH}	Propagation delay time, low-to-high level output			9	12	16	ns
t_{PHL}	Propagation delay time, high-to-low level output			9	12	16	ns
t_{PZH}	Propagation delay time, high-impedance to high-level output	See Figure 6-3		27	38	ns	
t_{PHZ}	Propagation delay time, high-level to high-impedance output			7	16	ns	
t_{PZL}	Propagation delay time, high-impedance to low level output	See Figure 6-4		29	38	ns	
t_{PLZ}	Propagation delay time, low-level to high-impedance output			12	16	ns	
$t_{sk(P)}$	Pulse skew ($ (t_{PLH} - t_{PHL}) $)			0.2	1	ns	
$t_{sk(O)}$	output skew (see Note 4)				2	ns	
$t_{sk(PP)}$	Part-to-part skew (see Note 5)				2	ns	

(1) All typical values are at $V_{CC} = 5\text{ V}$ and 25°C .

(2) Outputs skew ($t_{sk(O)}$) is the magnitude of the time delay difference between the outputs of a single device with all of the inputs connected together.

(3) Part-to-part skew ($t_{sk(PP)}$) is the magnitude of the difference in propagation delay times between any specified terminals of two devices when both devices operate with the same input signals, the same supply voltages, at the same temperature, and have identical packages and test circuits.

5.8 Typical Characteristics

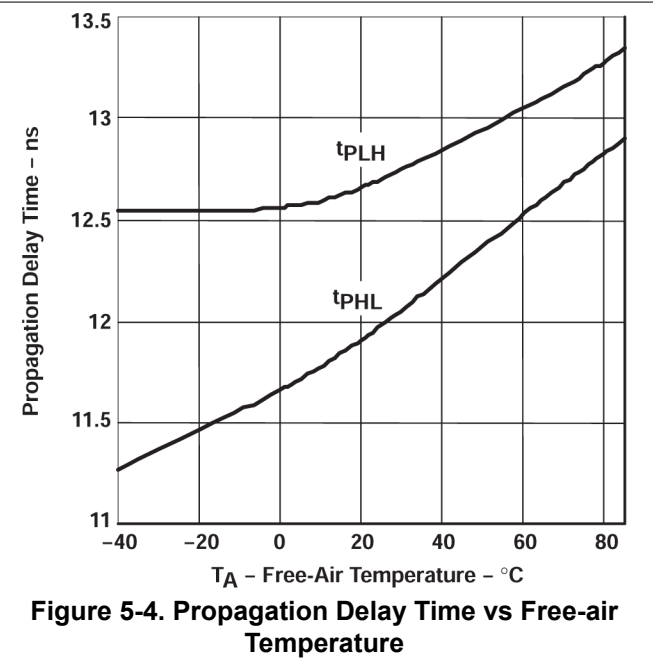
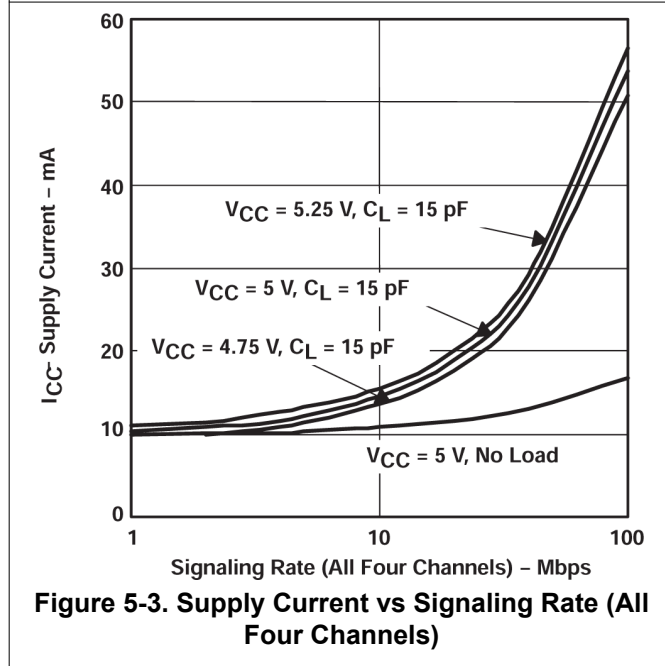
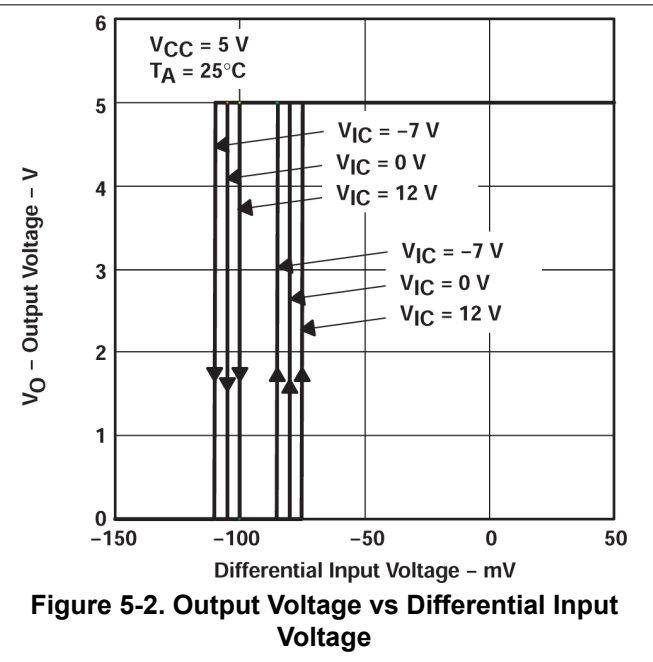
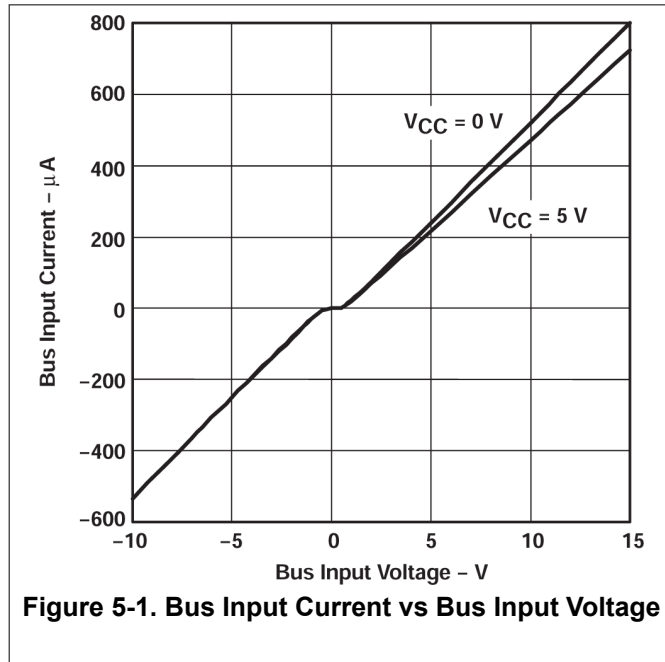

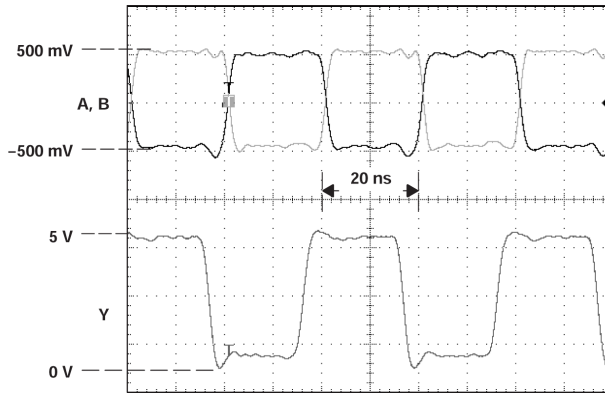

Figure 5-5. Receiver Inputs and Outputs, 50 Mbps Signaling Rate

6 Parameter Measurement Information

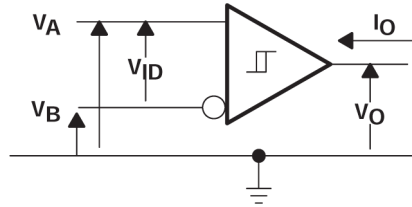

Figure 6-1. Voltage and Current Definitions

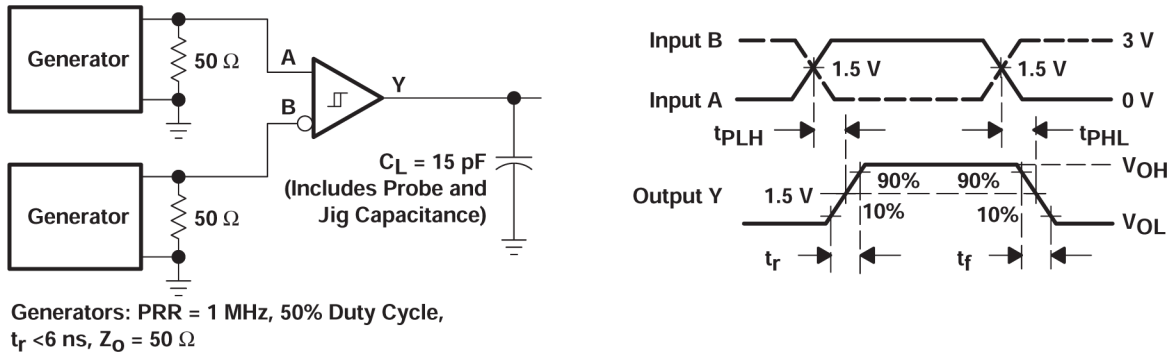

Figure 6-2. Switching Test Circuit and Waveforms

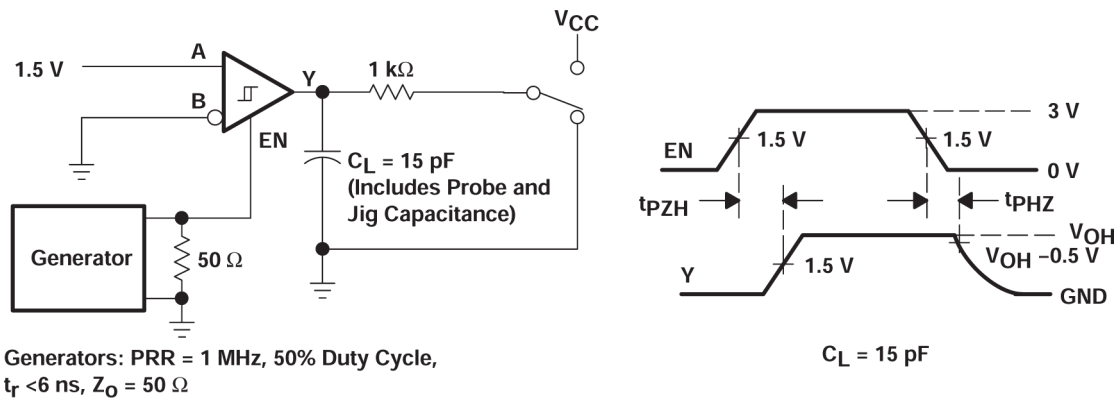

Figure 6-3. Test Circuit Waveforms, t_{PZH} and t_{PHZ}

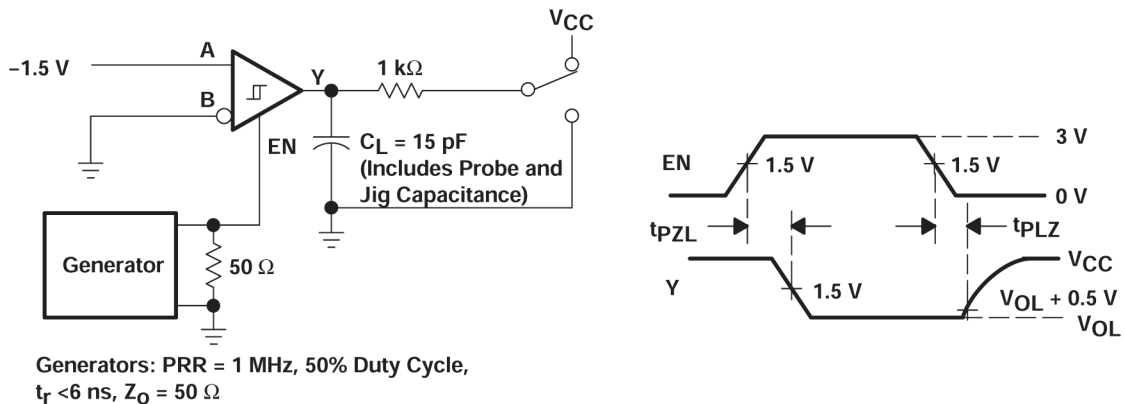

Figure 6-4. Test Circuit Waveforms, t_{PZL} and t_{PLZ}

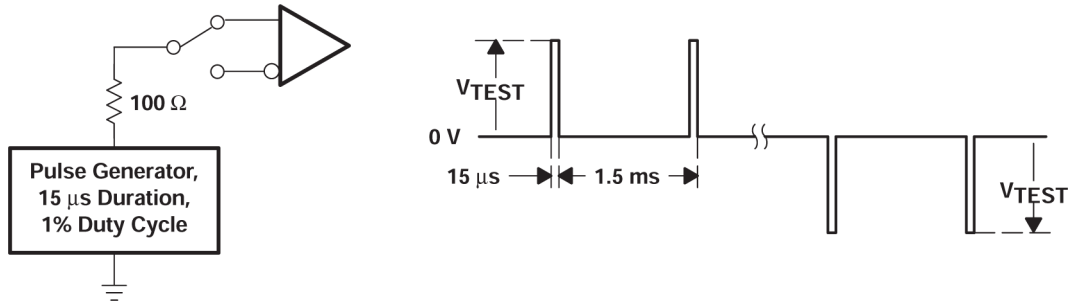

Figure 6-5. Test Circuit and Waveform, Transient Over-Voltage Test

7 Detailed Description

7.1 Device Functional Modes

Table 7-1. Functional Table (Each Receiver)

DIFFERENTIAL INPUTS A – B (V_{ID})	ENABLE EN ⁽¹⁾	OUTPUT Y
$V_{ID} \leq -0.2$ V	H	L
-0.2 V $< V_{ID} < -0.01$ V	H	?
-0.01 V $\leq V_{ID}$	H	H
X	L	Z
X	OPEN	Z
Short circuit	H	H
Open circuit	H	H

(1) H = high level, L = low level, X = irrelevant, Z = high impedance (off), ? = indeterminate

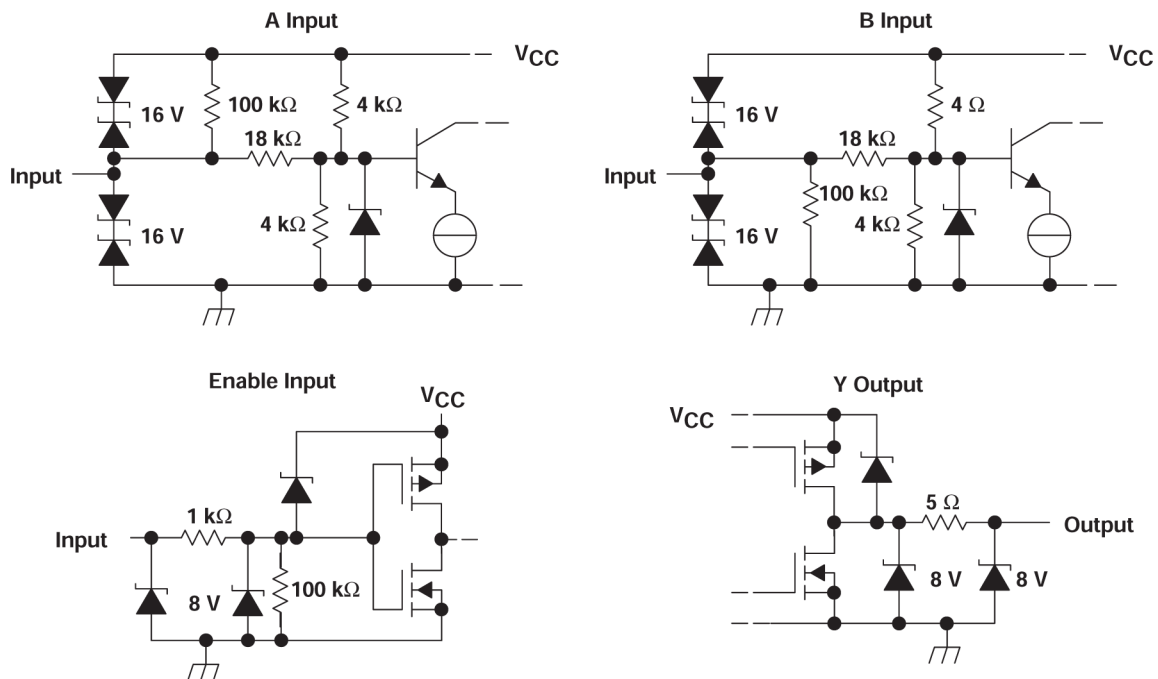

Figure 7-1. Equivalent Input and Output Schematic Diagrams

8 Application and Implementation

Note

Information in the following applications sections is not part of the TI component specification, and TI does not warrant its accuracy or completeness. TI's customers are responsible for determining suitability of components for their purposes, as well as validating and testing their design implementation to confirm system functionality.

8.1 Typical Application

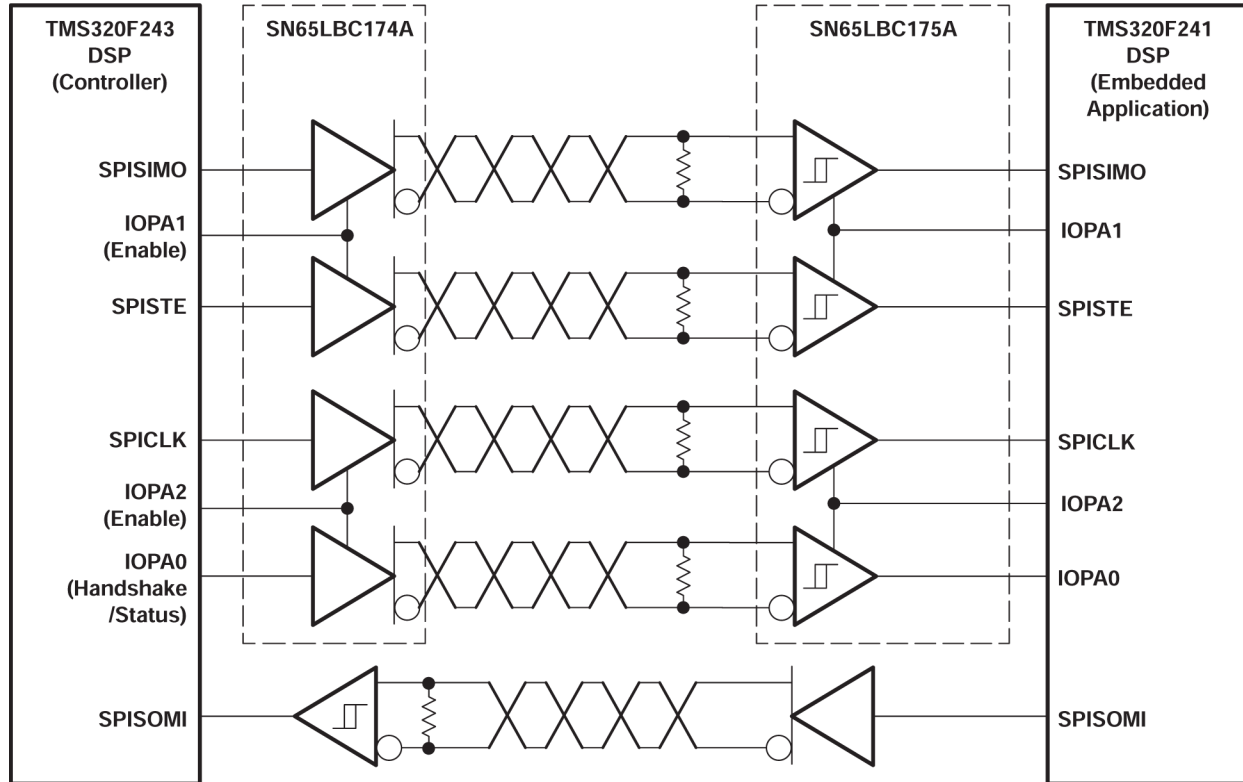

Figure 8-1. Typical Application Circuit, DSP-to-DSP Link via Serial Peripheral Interface

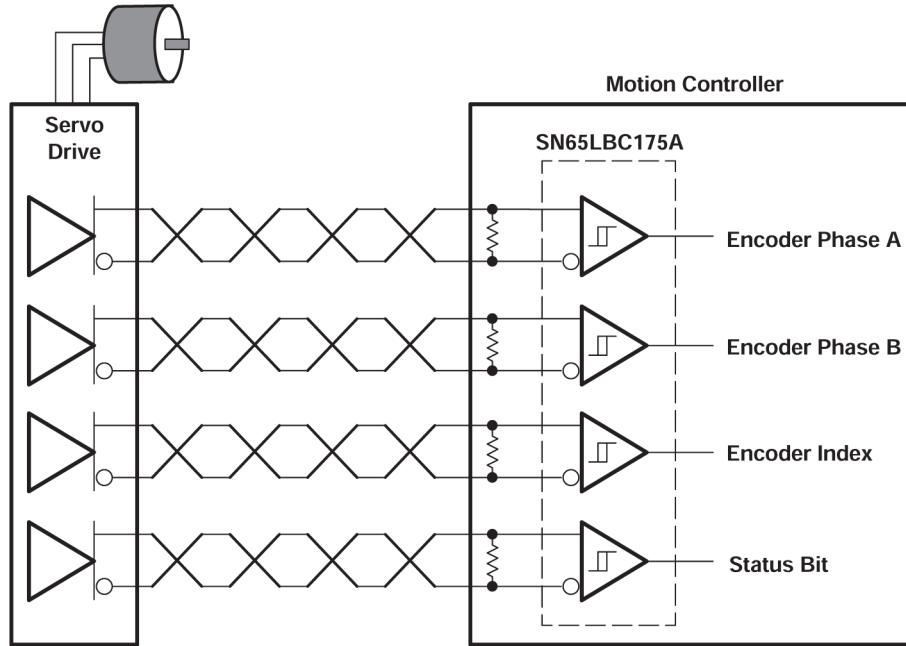

Figure 8-2. Typical Application Circuit, High-Speed Servomotor Encoder Interface

9 Device and Documentation Support

TI offers an extensive line of development tools. Tools and software to evaluate the performance of the device, generate code, and develop solutions are listed below.

9.1 Receiving Notification of Documentation Updates

To receive notification of documentation updates, navigate to the device product folder on ti.com. Click on *Subscribe to updates* to register and receive a weekly digest of any product information that has changed. For change details, review the revision history included in any revised document.

9.2 Support Resources

[TI E2E™ support forums](#) are an engineer's go-to source for fast, verified answers and design help — straight from the experts. Search existing answers or ask your own question to get the quick design help you need.

Linked content is provided "AS IS" by the respective contributors. They do not constitute TI specifications and do not necessarily reflect TI's views; see TI's [Terms of Use](#).

9.3 Trademarks

TI E2E™ is a trademark of Texas Instruments.

All trademarks are the property of their respective owners.

9.4 Electrostatic Discharge Caution



This integrated circuit can be damaged by ESD. Texas Instruments recommends that all integrated circuits be handled with appropriate precautions. Failure to observe proper handling and installation procedures can cause damage.

ESD damage can range from subtle performance degradation to complete device failure. Precision integrated circuits may be more susceptible to damage because very small parametric changes could cause the device not to meet its published specifications.

9.5 Glossary

[TI Glossary](#) This glossary lists and explains terms, acronyms, and definitions.

10 Revision History

NOTE: Page numbers for previous revisions may differ from page numbers in the current version.

Changes from Revision C (March 2009) to Revision D (November 2023)	Page
• Changed the numbering format for tables, figures, and cross-references throughout the document.....	1

11 Mechanical, Packaging, and Orderable Information

The following pages include mechanical, packaging, and orderable information. This information is the most current data available for the designated devices. This data is subject to change without notice and revision of this document. For browser-based versions of this data sheet, refer to the left-hand navigation.

PACKAGING INFORMATION

Orderable Device	Status (1)	Package Type	Package Drawing	Pins	Package Qty	Eco Plan (2)	Lead finish/ Ball material (6)	MSL Peak Temp (3)	Op Temp (°C)	Device Marking (4/5)	Samples
SN65LBC175AD	OBSOLETE	SOIC	D	16		TBD	Call TI	Call TI	-40 to 85	65LBC175A	
SN65LBC175ADR	ACTIVE	SOIC	D	16	2500	RoHS & Green	NIPDAU	Level-1-260C-UNLIM	-40 to 85	65LBC175A	Samples
SN65LBC175AN	ACTIVE	PDIP	N	16	25	RoHS & Green	NIPDAU	N / A for Pkg Type	-40 to 85	65LBC175A	Samples
SN75LBC175AD	OBSOLETE	SOIC	D	16		TBD	Call TI	Call TI	0 to 70	75LBC175A	
SN75LBC175ADR	OBSOLETE	SOIC	D	16		TBD	Call TI	Call TI	0 to 70	75LBC175A	
SN75LBC175AN	OBSOLETE	PDIP	N	16		TBD	Call TI	Call TI	0 to 70	75LBC175A	

(1) The marketing status values are defined as follows:

ACTIVE: Product device recommended for new designs.

LIFEBUY: TI has announced that the device will be discontinued, and a lifetime-buy period is in effect.

NRND: Not recommended for new designs. Device is in production to support existing customers, but TI does not recommend using this part in a new design.

PREVIEW: Device has been announced but is not in production. Samples may or may not be available.

OBSOLETE: TI has discontinued the production of the device.

(2) **RoHS:** TI defines "RoHS" to mean semiconductor products that are compliant with the current EU RoHS requirements for all 10 RoHS substances, including the requirement that RoHS substance do not exceed 0.1% by weight in homogeneous materials. Where designed to be soldered at high temperatures, "RoHS" products are suitable for use in specified lead-free processes. TI may reference these types of products as "Pb-Free".

RoHS Exempt: TI defines "RoHS Exempt" to mean products that contain lead but are compliant with EU RoHS pursuant to a specific EU RoHS exemption.

Green: TI defines "Green" to mean the content of Chlorine (Cl) and Bromine (Br) based flame retardants meet JS709B low halogen requirements of <=1000ppm threshold. Antimony trioxide based flame retardants must also meet the <=1000ppm threshold requirement.

(3) MSL, Peak Temp. - The Moisture Sensitivity Level rating according to the JEDEC industry standard classifications, and peak solder temperature.

(4) There may be additional marking, which relates to the logo, the lot trace code information, or the environmental category on the device.

(5) Multiple Device Markings will be inside parentheses. Only one Device Marking contained in parentheses and separated by a "~" will appear on a device. If a line is indented then it is a continuation of the previous line and the two combined represent the entire Device Marking for that device.

(6) Lead finish/Ball material - Orderable Devices may have multiple material finish options. Finish options are separated by a vertical ruled line. Lead finish/Ball material values may wrap to two lines if the finish value exceeds the maximum column width.

Important Information and Disclaimer:The information provided on this page represents TI's knowledge and belief as of the date that it is provided. TI bases its knowledge and belief on information provided by third parties, and makes no representation or warranty as to the accuracy of such information. Efforts are underway to better integrate information from third parties. TI has taken and

continues to take reasonable steps to provide representative and accurate information but may not have conducted destructive testing or chemical analysis on incoming materials and chemicals. TI and TI suppliers consider certain information to be proprietary, and thus CAS numbers and other limited information may not be available for release.

In no event shall TI's liability arising out of such information exceed the total purchase price of the TI part(s) at issue in this document sold by TI to Customer on an annual basis.

OTHER QUALIFIED VERSIONS OF SN65LBC175A :

- Enhanced Product : [SN65LBC175A-EP](#)

NOTE: Qualified Version Definitions:

- Enhanced Product - Supports Defense, Aerospace and Medical Applications

TAPE AND REEL INFORMATION

QUADRANT ASSIGNMENTS FOR PIN 1 ORIENTATION IN TAPE

*All dimensions are nominal

Device	Package Type	Package Drawing	Pins	SPQ	Reel Diameter (mm)	Reel Width W1 (mm)	A0 (mm)	B0 (mm)	K0 (mm)	P1 (mm)	W (mm)	Pin1 Quadrant
SN65LBC175ADR	SOIC	D	16	2500	330.0	16.4	6.5	10.3	2.1	8.0	16.0	Q1

TAPE AND REEL BOX DIMENSIONS

*All dimensions are nominal

Device	Package Type	Package Drawing	Pins	SPQ	Length (mm)	Width (mm)	Height (mm)
SN65LBC175ADR	SOIC	D	16	2500	353.0	353.0	32.0

TUBE

*All dimensions are nominal

Device	Package Name	Package Type	Pins	SPQ	L (mm)	W (mm)	T (μm)	B (mm)
SN65LBC175AN	N	PDIP	16	25	506	13.97	11230	4.32

N (R-PDIP-T**)

PLASTIC DUAL-IN-LINE PACKAGE

16 PINS SHOWN



4040049/E 12/2002

- NOTES:
- A. All linear dimensions are in inches (millimeters).
 - B. This drawing is subject to change without notice.
 - (C) Falls within JEDEC MS-001, except 18 and 20 pin minimum body length (Dim A).
 - (D) The 20 pin end lead shoulder width is a vendor option, either half or full width.

D (R-PDSO-G16)

PLASTIC SMALL OUTLINE



- NOTES:
- A. All linear dimensions are in inches (millimeters).
 - B. This drawing is subject to change without notice.
 - C. Body length does not include mold flash, protrusions, or gate burrs. Mold flash, protrusions, or gate burrs shall not exceed 0.006 (0,15) each side.
 - D. Body width does not include interlead flash. Interlead flash shall not exceed 0.017 (0,43) each side.
 - E. Reference JEDEC MS-012 variation AC.

IMPORTANT NOTICE AND DISCLAIMER

TI PROVIDES TECHNICAL AND RELIABILITY DATA (INCLUDING DATA SHEETS), DESIGN RESOURCES (INCLUDING REFERENCE DESIGNS), APPLICATION OR OTHER DESIGN ADVICE, WEB TOOLS, SAFETY INFORMATION, AND OTHER RESOURCES "AS IS" AND WITH ALL FAULTS, AND DISCLAIMS ALL WARRANTIES, EXPRESS AND IMPLIED, INCLUDING WITHOUT LIMITATION ANY IMPLIED WARRANTIES OF MERCHANTABILITY, FITNESS FOR A PARTICULAR PURPOSE OR NON-INFRINGEMENT OF THIRD PARTY INTELLECTUAL PROPERTY RIGHTS.

These resources are intended for skilled developers designing with TI products. You are solely responsible for (1) selecting the appropriate TI products for your application, (2) designing, validating and testing your application, and (3) ensuring your application meets applicable standards, and any other safety, security, regulatory or other requirements.

These resources are subject to change without notice. TI grants you permission to use these resources only for development of an application that uses the TI products described in the resource. Other reproduction and display of these resources is prohibited. No license is granted to any other TI intellectual property right or to any third party intellectual property right. TI disclaims responsibility for, and you will fully indemnify TI and its representatives against, any claims, damages, costs, losses, and liabilities arising out of your use of these resources.

TI's products are provided subject to [TI's Terms of Sale](#) or other applicable terms available either on [ti.com](https://www.ti.com) or provided in conjunction with such TI products. TI's provision of these resources does not expand or otherwise alter TI's applicable warranties or warranty disclaimers for TI products.

TI objects to and rejects any additional or different terms you may have proposed.

Mailing Address: Texas Instruments, Post Office Box 655303, Dallas, Texas 75265
Copyright © 2024, Texas Instruments Incorporated