

SN74HCS259 8-Bit Addressable Latches with Schmitt-Trigger Inputs

1 Features

- Wide operating voltage range: 2 V to 6 V
- Schmitt-trigger inputs allow for slow or noisy input signals
- Low power consumption
 - Typical I_{CC} of 100 nA
 - Typical input leakage current of ± 100 nA
- ± 7.8 -mA output drive at 6 V
- Extended ambient temperature range: -40°C to $+125^{\circ}\text{C}$, T_A

2 Applications

- Memory device selection with shared data bus
- Reduce required number of outputs for chip select applications
- Route data

3 Description

The SN74HCS259 8-bit addressable latches are designed for general-purpose storage applications in digital systems. Specific uses include working registers, serial-holding registers, and active-high decoders or demultiplexers. They are multifunctional devices capable of storing single-line data in eight addressable latches and being a 1-of-8 decoder or demultiplexer with active-high outputs.

Device Information

| PART NUMBER | PACKAGE ⁽¹⁾ | BODY SIZE (NOM) |
|--------------|------------------------|-------------------|
| SN74HCS259PW | TSSOP (16) | 5.00 mm x 4.40 mm |
| SN74HCS259D | SOIC (16) | 9.90 mm x 3.90 mm |

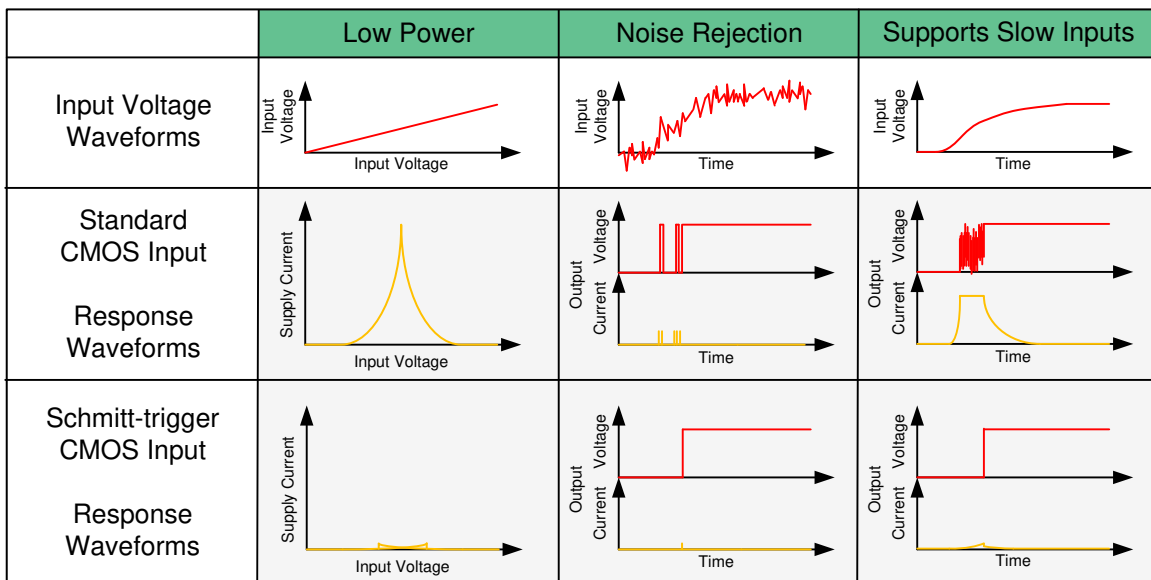

Benefits of Schmitt-trigger inputs



Table of Contents

| | | | |
|--|---|--|----|
| 1 Features | 1 | 8.3 Feature Description..... | 10 |
| 2 Applications | 1 | 8.4 Device Functional Modes..... | 11 |
| 3 Description | 1 | 9 Application and Implementation | 12 |
| 4 Revision History | 2 | 9.1 Application Information..... | 12 |
| 5 Pin Configuration and Functions | 3 | 9.2 Typical Application..... | 12 |
| 6 Specifications | 4 | 10 Power Supply Recommendations | 15 |
| 6.1 Absolute Maximum Ratings..... | 4 | 11 Layout | 15 |
| 6.2 ESD Ratings..... | 4 | 11.1 Layout Guidelines..... | 15 |
| 6.3 Recommended Operating Conditions..... | 4 | 11.2 Layout Example..... | 15 |
| 6.4 Thermal Information..... | 4 | 12 Device and Documentation Support | 16 |
| 6.5 Electrical Characteristics..... | 5 | 12.1 Documentation Support..... | 16 |
| 6.6 Timing Characteristics..... | 5 | 12.2 Receiving Notification of Documentation Updates.. | 16 |
| 6.7 Switching Characteristics..... | 6 | 12.3 Support Resources..... | 16 |
| 6.8 Operating Characteristics..... | 6 | 12.4 Trademarks..... | 16 |
| 6.9 Typical Characteristics..... | 7 | 12.5 Electrostatic Discharge Caution..... | 16 |
| 7 Parameter Measurement Information | 8 | 12.6 Glossary..... | 16 |
| 8 Detailed Description | 9 | 13 Mechanical, Packaging, and Orderable Information | 17 |
| 8.1 Overview..... | 9 | | |
| 8.2 Functional Block Diagram..... | 9 | | |

4 Revision History

NOTE: Page numbers for previous revisions may differ from page numbers in the current version.

| DATE | REVISION | NOTES |
|----------------|----------|-----------------|
| September 2020 | * | Initial Release |

5 Pin Configuration and Functions

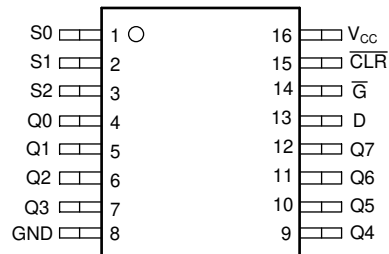

D or PW Package 16-Pin SOIC or TSSOP Top View

Pin Functions

| PIN | | I/O ⁽¹⁾ | DESCRIPTION |
|-------------------|------------------|--------------------|-------------------------|
| SOIC or TSSOP NO. | NAME | | |
| 1 | S0 | I | Address select 0 |
| 2 | S1 | I | Address select 1 |
| 3 | S2 | I | Address select 2 |
| 4 | Q0 | O | Output 0 |
| 5 | Q1 | O | Output 1 |
| 6 | Q2 | O | Output 2 |
| 7 | Q3 | O | Output 3 |
| 8 | GND | — | Ground |
| 9 | Q4 | O | Output 4 |
| 10 | Q5 | O | Output 5 |
| 11 | Q6 | O | Output 6 |
| 12 | Q7 | O | Output 7 |
| 13 | D | I | Data input |
| 14 | \overline{G} | I | Enable, active low |
| 15 | \overline{CLR} | O | Clear input, active low |
| 16 | V _{CC} | — | Positive supply |

6 Specifications

6.1 Absolute Maximum Ratings

over operating free-air temperature range (unless otherwise noted)⁽¹⁾

| | | MIN | MAX | UNIT |
|------------------|---|---|-----|--------|
| V _{CC} | Supply voltage | -0.5 | 7 | V |
| I _{IK} | Input clamp current ⁽²⁾ | V _I < -0.5 V or V _I > V _{CC} + 0.5 V | | ±20 mA |
| I _{OK} | Output clamp current ⁽²⁾ | V _I < -0.5 V or V _I > V _{CC} + 0.5 V | | ±20 mA |
| I _O | Continuous output current | V _O = 0 to V _{CC} | | ±35 mA |
| | Continuous current through V _{CC} or GND | | | ±70 mA |
| T _J | Junction temperature ⁽³⁾ | | | 150 °C |
| T _{stg} | Storage temperature | -65 | 150 | °C |

- (1) Stresses beyond those listed under *Absolute Maximum Rating* may cause permanent damage to the device. These are stress ratings only, which do not imply functional operation of the device at these or any other conditions beyond those indicated under *Recommended Operating Condition*. Exposure to absolute-maximum-rated conditions for extended periods may affect device reliability.
- (2) The input and output voltage ratings may be exceeded if the input and output current ratings are observed.
- (3) Guaranteed by design.

6.2 ESD Ratings

| | | | VALUE | UNIT |
|--------------------|-------------------------|--|-------|------|
| V _(ESD) | Electrostatic discharge | Human-body model (HBM), per ANSI/ESDA/ JEDEC JS-001 ⁽¹⁾ | ±4000 | V |
| | | Charged-device model (CDM), per JEDEC specification JESD22-C101 ⁽²⁾ | ±1500 | |

- (1) JEDEC document JEP155 states that 500-V HBM allows safe manufacturing with a standard ESD control process.
- (2) JEDEC document JEP157 states that 250-V CDM allows safe manufacturing with a standard ESD control process.

6.3 Recommended Operating Conditions

over operating free-air temperature range (unless otherwise noted)

| | | MIN | NOM | MAX | UNIT |
|-----------------|---------------------|-----|-----|-----------------|------|
| V _{CC} | Supply voltage | 2 | 5 | 6 | V |
| V _I | Input voltage | 0 | | V _{CC} | V |
| V _O | Output voltage | 0 | | V _{CC} | V |
| T _A | Ambient temperature | -40 | | 125 | °C |

6.4 Thermal Information

| THERMAL METRIC ⁽¹⁾ | | SN74HCS259 | | UNIT |
|-------------------------------|--|------------|----------|------|
| | | PW (TSSOP) | D (SOIC) | |
| | | 16 PINS | 16 PINS | |
| R _{θJA} | Junction-to-ambient thermal resistance | 141.2 | 122.2 | °C/W |
| R _{θJC(top)} | Junction-to-case (top) thermal resistance | 78.8 | 80.9 | °C/W |
| R _{θJB} | Junction-to-board thermal resistance | 85.8 | 80.6 | °C/W |
| Ψ _{JT} | Junction-to-top characterization parameter | 27.7 | 40.4 | °C/W |
| Ψ _{JB} | Junction-to-board characterization parameter | 85.5 | 80.3 | °C/W |
| R _{θJC(bot)} | Junction-to-case (bottom) thermal resistance | N/A | N/A | °C/W |

- (1) For more information about traditional and new thermal metrics, see the [Semiconductor and IC Package Thermal Metrics](#) application report.

6.5 Electrical Characteristics

over operating free-air temperature range; typical values measured at $T_A = 25^\circ\text{C}$ (unless otherwise noted).

| PARAMETER | | TEST CONDITIONS | | V_{CC} | MIN | TYP | MAX | UNIT |
|--------------|---|--------------------------------|----------------------------|------------|----------------|------------------|------------|---------------|
| V_{T+} | Positive switching threshold | | | 2 V | 0.7 | | 1.5 | V |
| | | | | 4.5 V | 1.7 | | 3.15 | |
| | | | | 6 V | 2.1 | | 4.2 | |
| V_{T-} | Negative switching threshold | | | 2 V | 0.3 | | 1.0 | V |
| | | | | 4.5 V | 0.9 | | 2.2 | |
| | | | | 6 V | 1.2 | | 3.0 | |
| ΔV_T | Hysteresis ($V_{T+} - V_{T-}$) ⁽¹⁾ | | | 2 V | 0.2 | | 1.0 | V |
| | | | | 4.5 V | 0.4 | | 1.4 | |
| | | | | 6 V | 0.6 | | 1.6 | |
| V_{OH} | High-level output voltage | $V_I = V_{IH}$ or V_{IL} | $I_{OH} = -20 \mu\text{A}$ | 2 V to 6 V | $V_{CC} - 0.1$ | $V_{CC} - 0.002$ | | V |
| | | | $I_{OH} = -6 \text{ mA}$ | 4.5 V | 4.0 | 4.3 | | |
| | | | $I_{OH} = -7.8 \text{ mA}$ | 6 V | 5.4 | 5.75 | | |
| V_{OL} | Low-level output voltage | $V_I = V_{IH}$ or V_{IL} | $I_{OL} = 20 \mu\text{A}$ | 2 V to 6 V | | 0.002 | 0.1 | V |
| | | | $I_{OL} = 6 \text{ mA}$ | 4.5 V | | 0.18 | 0.30 | |
| | | | $I_{OL} = 7.8 \text{ mA}$ | 6 V | | 0.22 | 0.33 | |
| I_I | Input leakage current | $V_I = V_{CC}$ or 0 | | 6 V | | ± 100 | ± 1000 | nA |
| I_{CC} | Supply current | $V_I = V_{CC}$ or 0, $I_O = 0$ | | 6 V | | 0.1 | 2 | μA |
| C_i | Input capacitance | | | 2 V to 6 V | | | 5 | pF |

(1) Guaranteed by design.

6.6 Timing Characteristics

$C_L = 50 \text{ pF}$; over operating free-air temperature range (unless otherwise noted). See [Parameter Measurement Information](#).

| PARAMETER | | | V_{CC} | Operating free-air temperature (T_A) | | | | UNIT |
|-----------|----------------|--|----------|--|-----|----------------|-----|------|
| | | | | 25°C | | -40°C to 125°C | | |
| | | | | MIN | MAX | MIN | MAX | |
| t_w | Pulse duration | $\overline{\text{CLR}}$ low | 2 V | 5 | | 5 | ns | |
| | | | 4.5 V | 5 | | 5 | | |
| | | | 6 V | 5 | | 5 | | |
| | | $\overline{\text{G}}$ low | 2 V | 5 | | 5 | | |
| | | | 4.5 V | 5 | | 5 | | |
| | | | 6 V | 5 | | 5 | | |
| t_{su} | Setup time | Data or address before $\overline{\text{G}}\uparrow$ | 2 V | 5 | | 8 | ns | |
| | | | 4.5 V | 3 | | 4 | | |
| | | | 6 V | 3 | | 4 | | |
| t_h | Hold time | Data or address after $\overline{\text{G}}\uparrow$ | 2 V | 5 | | 5 | ns | |
| | | | 4.5 V | 5 | | 5 | | |
| | | | 6 V | 5 | | 5 | | |

6.7 Switching Characteristics

$C_L = 50$ pF; over operating free-air temperature range (unless otherwise noted). See [Parameter Measurement Information](#).

| PARAMETER | | FROM | TO | V_{CC} | Operating free-air temperature (T_A) | | | | | | UNIT |
|-----------|-------------------|------------------|------------|----------|--|-----|-----|----------------|-----|-----|------|
| | | | | | 25°C | | | –40°C to 125°C | | | |
| | | | | | MIN | TYP | MAX | MIN | TYP | MAX | |
| t_{pd} | Propagation delay | Data | Any Q | 2 V | 17 | 32 | | 48 | ns | | |
| | | | | 4.5 V | 7 | 12 | | 18 | | | |
| | | | | 6 V | 6 | 11 | | 15 | | | |
| | | Address | Any Q | 2 V | 16 | 34 | | 52 | | | |
| | | | | 4.5 V | 7 | 12 | | 20 | | | |
| | | | | 6 V | 6 | 11 | | 18 | | | |
| | | \overline{G} | Any Q | 2 V | 17 | 38 | | 55 | | | |
| | | | | 4.5 V | 7 | 16 | | 24 | | | |
| | | | | 6 V | 6 | 15 | | 21 | | | |
| t_{PHL} | Propagation delay | \overline{CLR} | Any Q | 2 V | 14 | 34 | | 51 | ns | | |
| | | | | 4.5 V | 7 | 12 | | 20 | | | |
| | | | | 6 V | 6 | 11 | | 16 | | | |
| t_t | Transition-time | | Any output | 2 V | | 9 | | 17 | ns | | |
| | | | | 4.5 V | | 5 | | 8 | | | |
| | | | | 6 V | | 4 | | 7 | | | |

6.8 Operating Characteristics

over operating free-air temperature range; typical values measured at $T_A = 25^\circ\text{C}$ (unless otherwise noted).

| PARAMETER | | TEST CONDITIONS | V_{CC} | MIN | TYP | MAX | UNIT |
|-----------|--|-----------------|------------|-----|-----|-----|------|
| C_{pd} | Power dissipation capacitance per gate | No load | 2 V to 6 V | | 10 | | pF |

6.9 Typical Characteristics

$T_A = 25^\circ\text{C}$

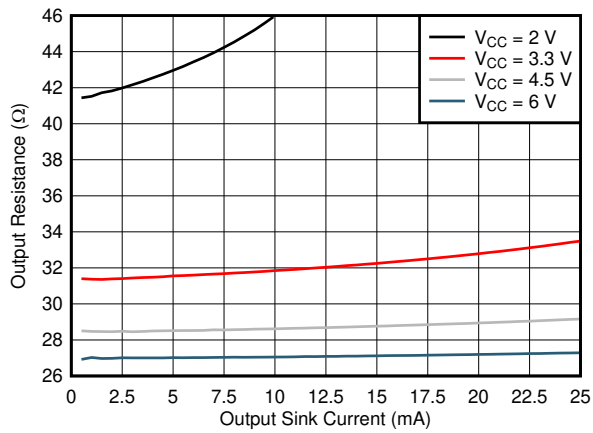

Figure 6-1. Output driver resistance in LOW state.

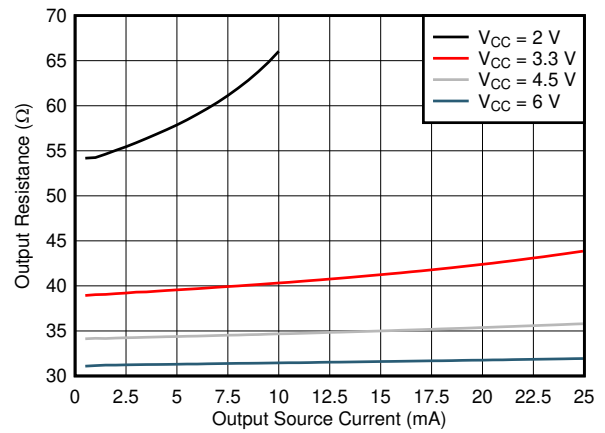

Figure 6-2. Output driver resistance in HIGH state.

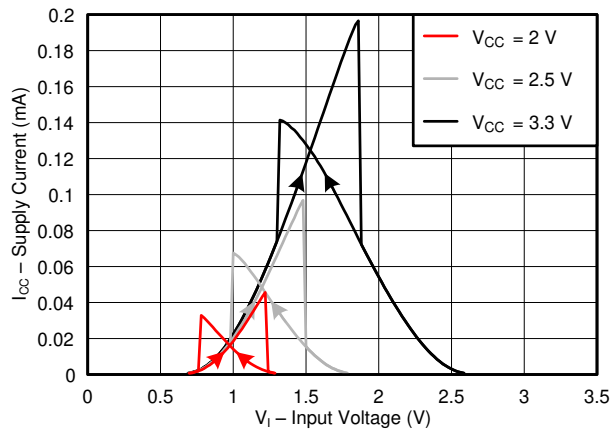

Figure 6-3. Supply current across input voltage, 2-, 2.5-, and 3.3-V supply

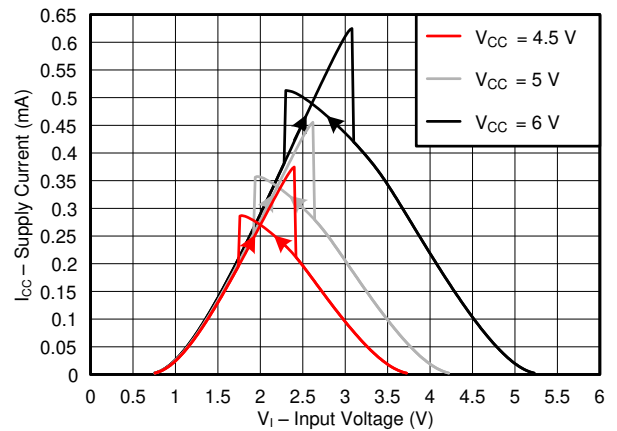

Figure 6-4. Supply current across input voltage, 4.5-, 5-, and 6-V supply

7 Parameter Measurement Information

Phase relationships between waveforms were chosen arbitrarily. All input pulses are supplied by generators having the following characteristics: $PRR \leq 1 \text{ MHz}$, $Z_O = 50 \ \Omega$, $t_t < 2.5 \text{ ns}$.

For clock inputs, f_{max} is measured when the input duty cycle is 50%.

The outputs are measured one at a time with one input transition per measurement.

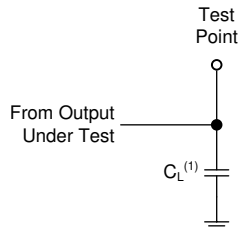

(1) C_L includes probe and test-fixture capacitance.

Figure 7-1. Load Circuit for Push-Pull Outputs

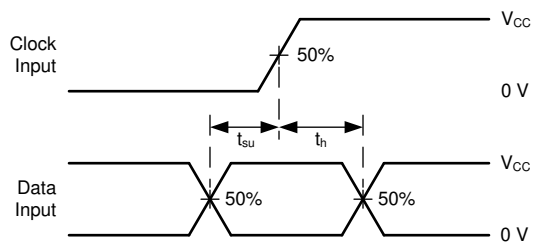

Figure 7-3. Voltage Waveforms, Setup and Hold Times

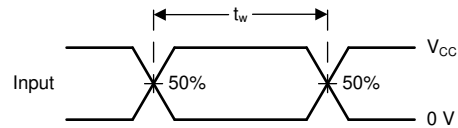
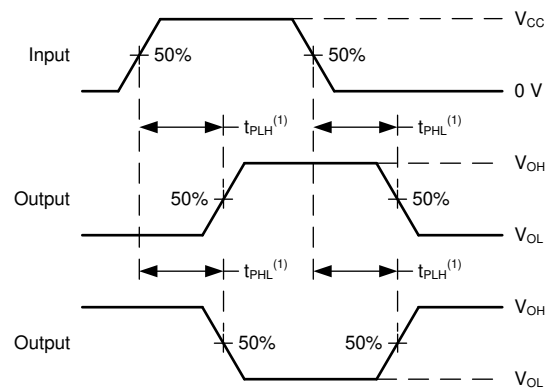
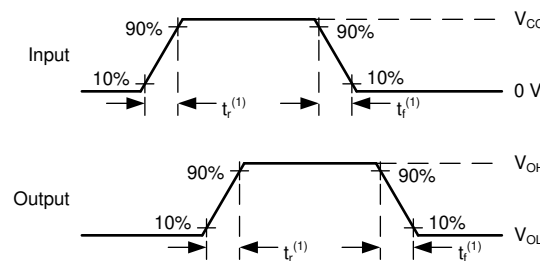

Figure 7-2. Voltage Waveforms, Pulse Duration



(1) The greater between t_{PLH} and t_{PHL} is the same as t_{pd} .

Figure 7-4. Voltage Waveforms Propagation Delays



(1) The greater between t_r and t_f is the same as t_t .

Figure 7-5. Voltage Waveforms, Input and Output Transition Times

8 Detailed Description

8.1 Overview

The SN74HCS259 8-bit addressable latches are designed for general-purpose storage applications in digital systems. Specific uses include working registers, serial-holding registers, and active-high decoders or demultiplexers. They are multifunctional devices capable of storing single-line data in eight addressable latches and being a 1-of-8 decoder or demultiplexer with active-high outputs.

Four distinct modes of operation are selectable by controlling the clear ($\overline{\text{CLR}}$) and enable ($\overline{\text{G}}$) inputs:

- Addressable-latch mode: $\overline{\text{CLR}} = \text{HIGH}$; $\overline{\text{G}} = \text{LOW}$
 - Data at the data-in terminal is written into the addressed latch
 - The addressed latch follows the data input, with all unaddressed latches remaining in their previous states
- Memory mode: $\overline{\text{CLR}} = \text{HIGH}$; $\overline{\text{G}} = \text{HIGH}$
 - All latches remain in their previous states and are unaffected by the data or address inputs
 - To eliminate the possibility of entering erroneous data in the latches, $\overline{\text{G}}$ should be held high (inactive) while the address lines are changing
- 1-of-8 decoding or demultiplexing mode: $\overline{\text{CLR}} = \text{LOW}$; $\overline{\text{G}} = \text{LOW}$
 - The addressed output follows the level of the D input with all other outputs low
- Clear mode: $\overline{\text{CLR}} = \text{LOW}$; $\overline{\text{G}} = \text{HIGH}$
 - All outputs are low and unaffected by the address and data inputs

8.2 Functional Block Diagram

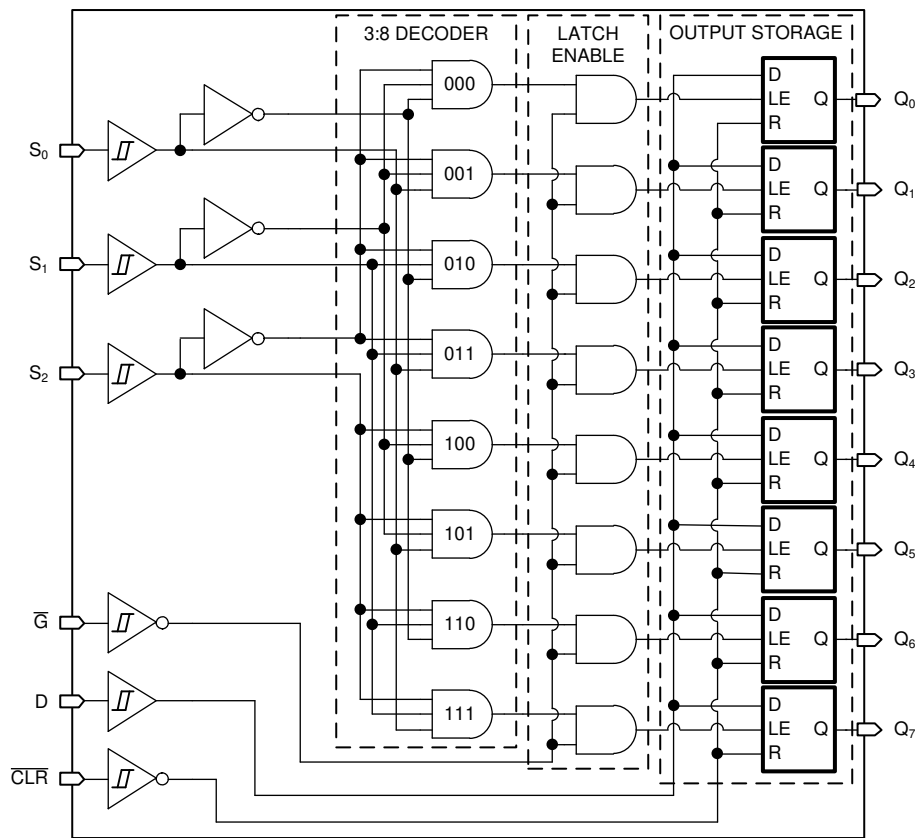

Figure 8-1. Logic Diagram (Positive Logic) for SN74HCS259

8.3 Feature Description

8.3.1 Balanced CMOS Push-Pull Outputs

This device includes balanced CMOS push-pull outputs. The term "balanced" indicates that the device can sink and source similar currents. The drive capability of this device may create fast edges into light loads so routing and load conditions should be considered to prevent ringing. Additionally, the outputs of this device are capable of driving larger currents than the device can sustain without being damaged. It is important for the output power of the device to be limited to avoid damage due to overcurrent. The electrical and thermal limits defined in the *Absolute Maximum Ratings* must be followed at all times.

Unused push-pull CMOS outputs should be left disconnected.

8.3.2 CMOS Schmitt-Trigger Inputs

This device includes inputs with the Schmitt-trigger architecture. These inputs are high impedance and are typically modeled as a resistor in parallel with the input capacitance given in the *Electrical Characteristics* table from the input to ground. The worst case resistance is calculated with the maximum input voltage, given in the *Absolute Maximum Ratings* table, and the maximum input leakage current, given in the *Electrical Characteristics* table, using Ohm's law ($R = V \div I$).

The Schmitt-trigger input architecture provides hysteresis as defined by ΔV_T in the *Electrical Characteristics* table, which makes this device extremely tolerant to slow or noisy inputs. While the inputs can be driven much slower than standard CMOS inputs, it is still recommended to properly terminate unused inputs. Driving the inputs with slow transitioning signals will increase dynamic current consumption of the device. For additional information regarding Schmitt-trigger inputs, please see [Understanding Schmitt Triggers](#).

8.3.3 Clamp Diode Structure

The inputs and outputs to this device have both positive and negative clamping diodes as depicted in [Electrical Placement of Clamping Diodes for Each Input and Output](#).

CAUTION

Voltages beyond the values specified in the *Absolute Maximum Ratings* table can cause damage to the device. The input and output voltage ratings may be exceeded if the input and output clamp-current ratings are observed.

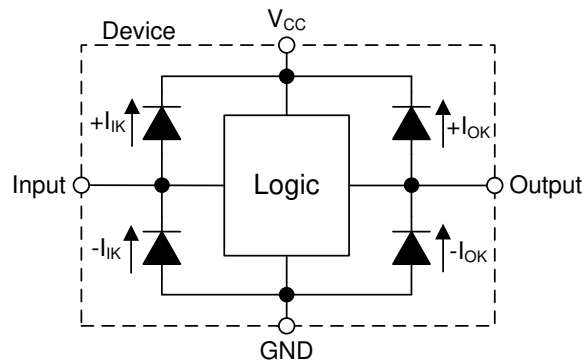

Figure 8-2. Electrical Placement of Clamping Diodes for Each Input and Output

8.4 Device Functional Modes

The [Function Table](#) and [Latch Selection Table](#) below list the functional modes of the SN74HCS259.

Table 8-1. Function Table

| INPUTS ⁽¹⁾ | | OUTPUT OF ADDRESSED LATCH ⁽²⁾ | EACH OTHER OUTPUT ⁽²⁾ | FUNCTION |
|-----------------------|-----------|--|-------------------------------------|----------------------|
| CLR | \bar{G} | | | |
| H | L | D | Q _{iO} | Addressable latch |
| H | H | Q _{iO} | Q _{iO} | Memory |
| L | L | D | L | 8-line demultiplexer |
| L | H | L | L | Clear |

- (1) H = High voltage level, L = Low voltage level
 (2) Q_{iO} = Previous output state of selected latch, D = Data input logic value

Table 8-2. Latch Selection Table

| SELECT INPUTS ⁽¹⁾ | | | LATCH ADDRESSED |
|------------------------------|----|----|--------------------|
| S2 | S1 | S0 | |
| L | L | L | 0 |
| L | L | H | 1 |
| L | H | L | 2 |
| L | H | H | 3 |
| H | L | L | 4 |
| H | L | H | 5 |
| H | H | L | 6 |
| H | H | H | 7 |

- (1) H = High Voltage Level, L = Low Voltage Level

9 Application and Implementation

Note

Information in the following applications sections is not part of the TI component specification, and TI does not warrant its accuracy or completeness. TI's customers are responsible for determining suitability of components for their purposes. Customers should validate and test their design implementation to confirm system functionality.

9.1 Application Information

The SN74HCS259 has four modes of operation. In this application, the 8-line demultiplexer mode is used to send data to one of eight possible destinations.

At system power-on, latched outputs are in an unknown state. The $\overline{\text{CLR}}$ input is held low while the $\overline{\text{G}}$ input is held high to clear the latches for operation. At this time, all outputs are in the low state.

An output is selected by setting S2, S1, and S0 as per the *Latch Selection Table*. After selection, the channel is activated by switching $\overline{\text{G}}$ to low. The logic value at the D input will appear at the selected output, allowing data transmission only to the selected device.

When the channel communication is complete, the $\overline{\text{G}}$ input is set to high to prevent erroneous outputs while the address inputs are changed, then switched back to low again to send data to the newly selected device.

9.2 Typical Application

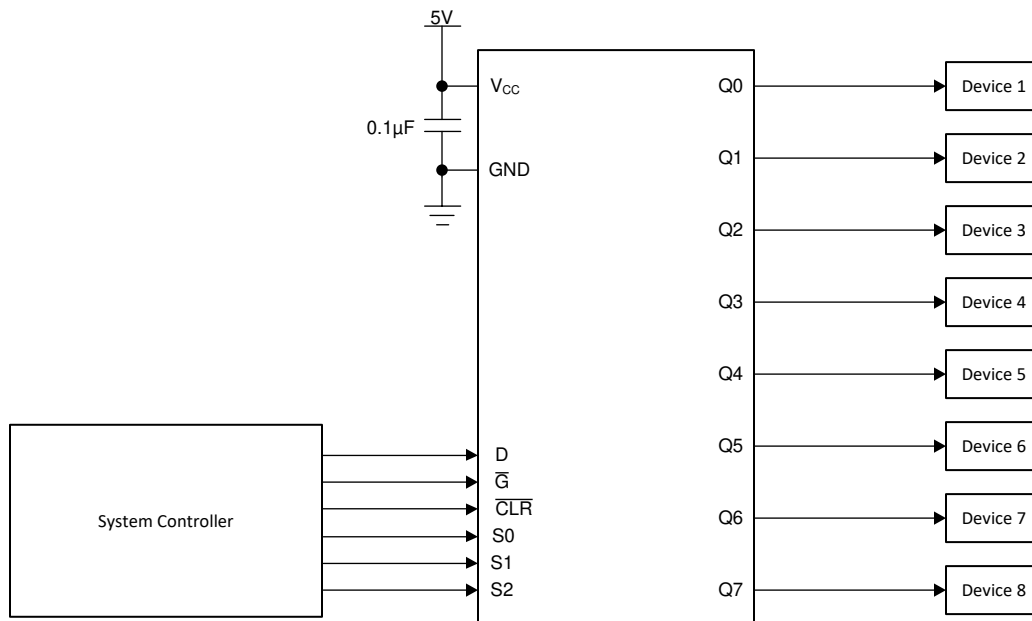

Figure 9-1. Typical application block diagram

9.2.1 Design Requirements

9.2.1.1 Power Considerations

Ensure the desired supply voltage is within the range specified in the *Recommended Operating Conditions*. The supply voltage sets the device's electrical characteristics as described in the *Electrical Characteristics*.

The positive voltage supply must be capable of sourcing current equal to the total current to be sourced by all outputs of the SN74HCS259 plus the maximum static supply current, I_{CC} , listed in *Electrical Characteristics* and any transient current required for switching. The logic device can only source as much current as is provided by the positive supply source. Be sure not to exceed the maximum total current through V_{CC} listed in the *Absolute Maximum Ratings*.

The ground must be capable of sinking current equal to the total current to be sunk by all outputs of the SN74HCS259 plus the maximum supply current, I_{CC} , listed in *Electrical Characteristics*, and any transient current required for switching. The logic device can only sink as much current as can be sunk into its ground connection. Be sure not to exceed the maximum total current through GND listed in the *Absolute Maximum Ratings*.

The SN74HCS259 can drive a load with a total capacitance less than or equal to 50 pF while still meeting all of the datasheet specifications. Larger capacitive loads can be applied, however it is not recommended to exceed 50 pF.

The SN74HCS259 can drive a load with total resistance described by $R_L \geq V_O / I_O$, with the output voltage and current defined in the *Electrical Characteristics* table with V_{OH} and V_{OL} . When outputting in the high state, the output voltage in the equation is defined as the difference between the measured output voltage and the supply voltage at the V_{CC} pin.

Total power consumption can be calculated using the information provided in [CMOS Power Consumption and Cpd Calculation](#).

Thermal increase can be calculated using the information provided in [Thermal Characteristics of Standard Linear and Logic \(SLL\) Packages and Devices](#).

CAUTION

The maximum junction temperature, $T_{J(max)}$ listed in the *Absolute Maximum Ratings*, is an additional limitation to prevent damage to the device. Do not violate any values listed in the *Absolute Maximum Ratings*. These limits are provided to prevent damage to the device.

9.2.1.2 Input Considerations

Input signals must cross $V_{t-(min)}$ to be considered a logic LOW, and $V_{t+(max)}$ to be considered a logic HIGH. Do not exceed the maximum input voltage range found in the *Absolute Maximum Ratings*.

Unused inputs must be terminated to either V_{CC} or ground. These can be directly terminated if the input is completely unused, or they can be connected with a pull-up or pull-down resistor if the input is to be used sometimes, but not always. A pull-up resistor is used for a default state of HIGH, and a pull-down resistor is used for a default state of LOW. The resistor size is limited by drive current of the controller, leakage current into the SN74HCS259, as specified in the *Electrical Characteristics*, and the desired input transition rate. A 10-k Ω resistor value is often used due to these factors.

The SN74HCS259 has no input signal transition rate requirements because it has Schmitt-trigger inputs.

Another benefit to having Schmitt-trigger inputs is the ability to reject noise. Noise with a large enough amplitude can still cause issues. To know how much noise is too much, please refer to the $\Delta V_{T(min)}$ in the *Electrical Characteristics*. This hysteresis value will provide the peak-to-peak limit.

Unlike what happens with standard CMOS inputs, Schmitt-trigger inputs can be held at any valid value without causing huge increases in power consumption. The typical additional current caused by holding an input at a value other than V_{CC} or ground is plotted in the *Typical Characteristics*.

Refer to the *Feature Description* section for additional information regarding the inputs for this device.

9.2.1.3 Output Considerations

The positive supply voltage is used to produce the output HIGH voltage. Drawing current from the output will decrease the output voltage as specified by the V_{OH} specification in the *Electrical Characteristics*. The ground voltage is used to produce the output LOW voltage. Sinking current into the output will increase the output voltage as specified by the V_{OL} specification in the *Electrical Characteristics*.

Push-pull outputs that could be in opposite states, even for a very short time period, should never be connected directly together. This can cause excessive current and damage to the device.

Two channels within the same device with the same input signals can be connected in parallel for additional output drive strength.

Unused outputs can be left floating. Do not connect outputs directly to V_{CC} or ground.

Refer to *Feature Description* section for additional information regarding the outputs for this device.

9.2.2 Detailed Design Procedure

1. Add a decoupling capacitor from V_{CC} to GND. The capacitor needs to be placed physically close to the device and electrically close to both the V_{CC} and GND pins. An example layout is shown in the *Layout* section.
2. Ensure the capacitive load at the output is ≤ 50 pF. This is not a hard limit, however it will ensure optimal performance. This can be accomplished by providing short, appropriately sized traces from the SN74HCS259 to the receiving device(s).
3. Ensure the resistive load at the output is larger than $(V_{CC} / I_{O(max)}) \Omega$. This will ensure that the maximum output current from the *Absolute Maximum Ratings* is not violated. Most CMOS inputs have a resistive load measured in megaohms; much larger than the minimum calculated above.
4. Thermal issues are rarely a concern for logic gates, however the power consumption and thermal increase can be calculated using the steps provided in the application report, [CMOS Power Consumption and Cpd Calculation](#).

9.2.3 Application Curve

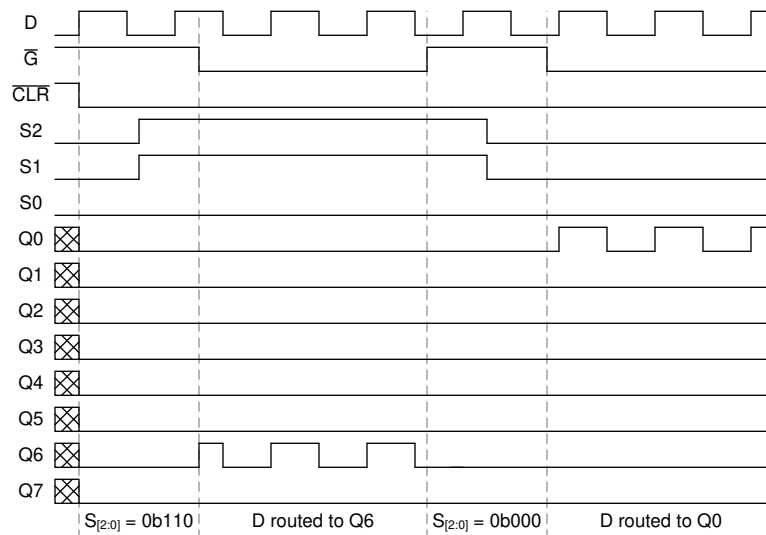

Figure 9-2. Application timing diagram

10 Power Supply Recommendations

The power supply can be any voltage between the minimum and maximum supply voltage rating located in the *Recommended Operating Conditions*. Each V_{CC} terminal should have a good bypass capacitor to prevent power disturbance. A 0.1- μF capacitor is recommended for this device. It is acceptable to parallel multiple bypass caps to reject different frequencies of noise. The 0.1- μF and 1- μF capacitors are commonly used in parallel. The bypass capacitor should be installed as close to the power terminal as possible for best results, as shown in given example layout image.

11 Layout

11.1 Layout Guidelines

When using multiple-input and multiple-channel logic devices inputs must not ever be left floating. In many cases, functions or parts of functions of digital logic devices are unused; for example, when only two inputs of a triple-input AND gate are used or only 3 of the 4 buffer gates are used. Such unused input pins must not be left unconnected because the undefined voltages at the outside connections result in undefined operational states. All unused inputs of digital logic devices must be connected to a logic high or logic low voltage, as defined by the input voltage specifications, to prevent them from floating. The logic level that must be applied to any particular unused input depends on the function of the device. Generally, the inputs are tied to GND or V_{CC} , whichever makes more sense for the logic function or is more convenient.

11.2 Layout Example

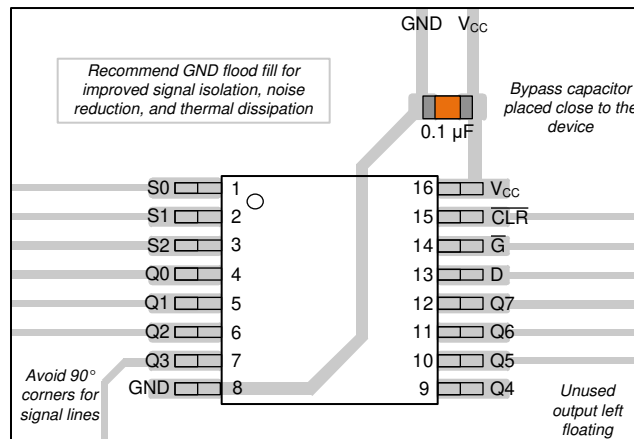

Figure 11-1. Example layout for the SN74HCS259 in the PW package.

12 Device and Documentation Support

TI offers an extensive line of development tools. Tools and software to evaluate the performance of the device, generate code, and develop solutions are listed below.

12.1 Documentation Support

12.1.1 Related Documentation

For related documentation see the following:

- Texas Instruments, [HCMOS Design Considerations application report](#) (SCLA007)
- Texas Instruments, [CMOS Power Consumption and \$C_{pd}\$ Calculation application report](#) (SDYA009)
- Texas Instruments, [Designing With Logic application report](#)

12.2 Receiving Notification of Documentation Updates

To receive notification of documentation updates, navigate to the device product folder on [ti.com](#). Click on *Subscribe to updates* to register and receive a weekly digest of any product information that has changed. For change details, review the revision history included in any revised document.

12.3 Support Resources

[TI E2E™ support forums](#) are an engineer's go-to source for fast, verified answers and design help — straight from the experts. Search existing answers or ask your own question to get the quick design help you need.

Linked content is provided "AS IS" by the respective contributors. They do not constitute TI specifications and do not necessarily reflect TI's views; see TI's [Terms of Use](#).

12.4 Trademarks

TI E2E™ is a trademark of Texas Instruments.

All other trademarks are the property of their respective owners.

12.5 Electrostatic Discharge Caution



This integrated circuit can be damaged by ESD. Texas Instruments recommends that all integrated circuits be handled with appropriate precautions. Failure to observe proper handling and installation procedures can cause damage.

ESD damage can range from subtle performance degradation to complete device failure. Precision integrated circuits may be more susceptible to damage because very small parametric changes could cause the device not to meet its published specifications.

12.6 Glossary

[TI Glossary](#) This glossary lists and explains terms, acronyms, and definitions.

13 Mechanical, Packaging, and Orderable Information

The following pages include mechanical, packaging, and orderable information. This information is the most current data available for the designated devices. This data is subject to change without notice and revision of this document. For browser-based versions of this data sheet, refer to the left-hand navigation.

PACKAGING INFORMATION

| Orderable Device | Status (1) | Package Type | Package Drawing | Pins | Package Qty | Eco Plan (2) | Lead finish/ Ball material (6) | MSL Peak Temp (3) | Op Temp (°C) | Device Marking (4/5) | Samples |
|------------------|---------------|--------------|-----------------|------|-------------|-----------------|--------------------------------------|----------------------|--------------|-------------------------|-------------------------|
| SN74HCS259DR | ACTIVE | SOIC | D | 16 | 2500 | RoHS & Green | NIPDAU SN | Level-1-260C-UNLIM | -40 to 125 | HCS259 | Samples |
| SN74HCS259PWR | ACTIVE | TSSOP | PW | 16 | 2000 | RoHS & Green | NIPDAU SN | Level-1-260C-UNLIM | -40 to 125 | HCS259 | Samples |

(1) The marketing status values are defined as follows:

ACTIVE: Product device recommended for new designs.

LIFEBUY: TI has announced that the device will be discontinued, and a lifetime-buy period is in effect.

NRND: Not recommended for new designs. Device is in production to support existing customers, but TI does not recommend using this part in a new design.

PREVIEW: Device has been announced but is not in production. Samples may or may not be available.

OBSOLETE: TI has discontinued the production of the device.

(2) **RoHS:** TI defines "RoHS" to mean semiconductor products that are compliant with the current EU RoHS requirements for all 10 RoHS substances, including the requirement that RoHS substance do not exceed 0.1% by weight in homogeneous materials. Where designed to be soldered at high temperatures, "RoHS" products are suitable for use in specified lead-free processes. TI may reference these types of products as "Pb-Free".

RoHS Exempt: TI defines "RoHS Exempt" to mean products that contain lead but are compliant with EU RoHS pursuant to a specific EU RoHS exemption.

Green: TI defines "Green" to mean the content of Chlorine (Cl) and Bromine (Br) based flame retardants meet JS709B low halogen requirements of <=1000ppm threshold. Antimony trioxide based flame retardants must also meet the <=1000ppm threshold requirement.

(3) MSL, Peak Temp. - The Moisture Sensitivity Level rating according to the JEDEC industry standard classifications, and peak solder temperature.

(4) There may be additional marking, which relates to the logo, the lot trace code information, or the environmental category on the device.

(5) Multiple Device Markings will be inside parentheses. Only one Device Marking contained in parentheses and separated by a "~" will appear on a device. If a line is indented then it is a continuation of the previous line and the two combined represent the entire Device Marking for that device.

(6) Lead finish/Ball material - Orderable Devices may have multiple material finish options. Finish options are separated by a vertical ruled line. Lead finish/Ball material values may wrap to two lines if the finish value exceeds the maximum column width.

Important Information and Disclaimer:The information provided on this page represents TI's knowledge and belief as of the date that it is provided. TI bases its knowledge and belief on information provided by third parties, and makes no representation or warranty as to the accuracy of such information. Efforts are underway to better integrate information from third parties. TI has taken and continues to take reasonable steps to provide representative and accurate information but may not have conducted destructive testing or chemical analysis on incoming materials and chemicals. TI and TI suppliers consider certain information to be proprietary, and thus CAS numbers and other limited information may not be available for release.

In no event shall TI's liability arising out of such information exceed the total purchase price of the TI part(s) at issue in this document sold by TI to Customer on an annual basis.

OTHER QUALIFIED VERSIONS OF SN74HCS259 :

- Automotive: [SN74HCS259-Q1](#)

NOTE: Qualified Version Definitions:

- Automotive - Q100 devices qualified for high-reliability automotive applications targeting zero defects

TAPE AND REEL INFORMATION

QUADRANT ASSIGNMENTS FOR PIN 1 ORIENTATION IN TAPE

*All dimensions are nominal

| Device | Package Type | Package Drawing | Pins | SPQ | Reel Diameter (mm) | Reel Width W1 (mm) | A0 (mm) | B0 (mm) | K0 (mm) | P1 (mm) | W (mm) | Pin1 Quadrant |
|---------------|--------------|-----------------|------|------|--------------------|--------------------|---------|---------|---------|---------|--------|---------------|
| SN74HCS259DR | SOIC | D | 16 | 2500 | 330.0 | 16.4 | 6.6 | 9.3 | 2.1 | 8.0 | 16.0 | Q1 |
| SN74HCS259DR | SOIC | D | 16 | 2500 | 330.0 | 16.4 | 6.5 | 10.3 | 2.1 | 8.0 | 16.0 | Q1 |
| SN74HCS259PWR | TSSOP | PW | 16 | 2000 | 330.0 | 12.4 | 6.9 | 5.6 | 1.6 | 8.0 | 12.0 | Q1 |

TAPE AND REEL BOX DIMENSIONS

*All dimensions are nominal

| Device | Package Type | Package Drawing | Pins | SPQ | Length (mm) | Width (mm) | Height (mm) |
|---------------|--------------|-----------------|------|------|-------------|------------|-------------|
| SN74HCS259DR | SOIC | D | 16 | 2500 | 366.0 | 364.0 | 50.0 |
| SN74HCS259DR | SOIC | D | 16 | 2500 | 356.0 | 356.0 | 35.0 |
| SN74HCS259PWR | TSSOP | PW | 16 | 2000 | 356.0 | 356.0 | 35.0 |

D (R-PDSO-G16)

PLASTIC SMALL OUTLINE



- NOTES:
- A. All linear dimensions are in inches (millimeters).
 - B. This drawing is subject to change without notice.
 - C. Body length does not include mold flash, protrusions, or gate burrs. Mold flash, protrusions, or gate burrs shall not exceed 0.006 (0,15) each side.
 - D. Body width does not include interlead flash. Interlead flash shall not exceed 0.017 (0,43) each side.
 - E. Reference JEDEC MS-012 variation AC.



4220204/A 02/2017

NOTES:

1. All linear dimensions are in millimeters. Any dimensions in parenthesis are for reference only. Dimensioning and tolerancing per ASME Y14.5M.
2. This drawing is subject to change without notice.
3. This dimension does not include mold flash, protrusions, or gate burrs. Mold flash, protrusions, or gate burrs shall not exceed 0.15 mm per side.
4. This dimension does not include interlead flash. Interlead flash shall not exceed 0.25 mm per side.
5. Reference JEDEC registration MO-153.

EXAMPLE BOARD LAYOUT

PW0016A

TSSOP - 1.2 mm max height

SMALL OUTLINE PACKAGE



LAND PATTERN EXAMPLE
EXPOSED METAL SHOWN
SCALE: 10X



4220204/A 02/2017

NOTES: (continued)

- 6. Publication IPC-7351 may have alternate designs.
- 7. Solder mask tolerances between and around signal pads can vary based on board fabrication site.

EXAMPLE STENCIL DESIGN

PW0016A

TSSOP - 1.2 mm max height

SMALL OUTLINE PACKAGE



SOLDER PASTE EXAMPLE
BASED ON 0.125 mm THICK STENCIL
SCALE: 10X

4220204/A 02/2017

NOTES: (continued)

8. Laser cutting apertures with trapezoidal walls and rounded corners may offer better paste release. IPC-7525 may have alternate design recommendations.
9. Board assembly site may have different recommendations for stencil design.

IMPORTANT NOTICE AND DISCLAIMER

TI PROVIDES TECHNICAL AND RELIABILITY DATA (INCLUDING DATA SHEETS), DESIGN RESOURCES (INCLUDING REFERENCE DESIGNS), APPLICATION OR OTHER DESIGN ADVICE, WEB TOOLS, SAFETY INFORMATION, AND OTHER RESOURCES "AS IS" AND WITH ALL FAULTS, AND DISCLAIMS ALL WARRANTIES, EXPRESS AND IMPLIED, INCLUDING WITHOUT LIMITATION ANY IMPLIED WARRANTIES OF MERCHANTABILITY, FITNESS FOR A PARTICULAR PURPOSE OR NON-INFRINGEMENT OF THIRD PARTY INTELLECTUAL PROPERTY RIGHTS.

These resources are intended for skilled developers designing with TI products. You are solely responsible for (1) selecting the appropriate TI products for your application, (2) designing, validating and testing your application, and (3) ensuring your application meets applicable standards, and any other safety, security, regulatory or other requirements.

These resources are subject to change without notice. TI grants you permission to use these resources only for development of an application that uses the TI products described in the resource. Other reproduction and display of these resources is prohibited. No license is granted to any other TI intellectual property right or to any third party intellectual property right. TI disclaims responsibility for, and you will fully indemnify TI and its representatives against, any claims, damages, costs, losses, and liabilities arising out of your use of these resources.

TI's products are provided subject to [TI's Terms of Sale](#) or other applicable terms available either on [ti.com](https://www.ti.com) or provided in conjunction with such TI products. TI's provision of these resources does not expand or otherwise alter TI's applicable warranties or warranty disclaimers for TI products.

TI objects to and rejects any additional or different terms you may have proposed.

Mailing Address: Texas Instruments, Post Office Box 655303, Dallas, Texas 75265
Copyright © 2023, Texas Instruments Incorporated