

TPS62090-Q1 3-A High-Efficiency Synchronous Step-Down Converter With DCS-Control™

1 Features

- Qualified for automotive applications
- AEC-Q100 qualified with the following results:
 - Device temperature grade 1: -40°C to 125°C junction operating temperature range
 - Device HBM ESD classification level H2
 - Device CDM ESD classification level C6
- 2.5-V to 6-V input voltage range
- DCS-Control™
- 95% converter efficiency
- Power save mode
- 20- μA operating quiescent current
- 100% duty cycle for lowest dropout
- 2.8-MHz and 1.4-MHz typical switching frequency
- 0.8-V to V_{IN} adjustable output voltage
- Output discharge function
- Adjustable soft start
- Hiccup short-circuit protection
- Output voltage tracking
- Wide output capacitance selection
- Available in 3-mm \times 3-mm 16-pin QFN package
- New product available: [TPS62813-Q1](#), 6-V step-down converter in 2-mm \times 3-mm QFN package with wettable flanks

2 Applications

- [Automotive applications](#)
- [Distributed power supplies](#)
- [Processor supply](#)
- [Battery-powered applications](#)

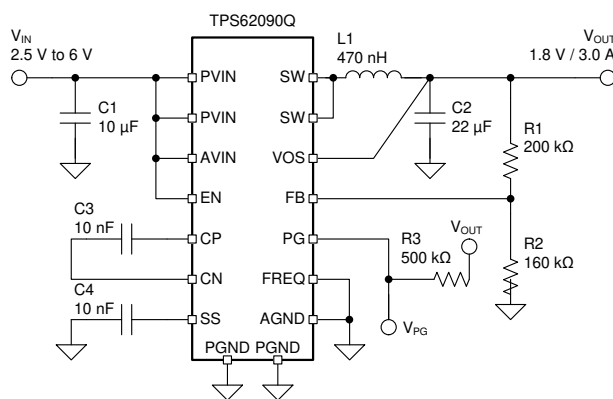

Copyright © 2016, Texas Instruments Incorporated

Typical Application

3 Description

The TPS62090Q devices are a family of high-frequency, synchronous, step-down converters optimized for small solution size, high efficiency, and are suitable for battery-powered applications. To maximize efficiency, the converters operate in pulse width modulation (PWM) mode with a nominal switching frequency of 2.8 MHz to 1.4 MHz and automatically enter power save mode operation at light load currents. When used in distributed power supplies and point-of-load regulation, the devices allow voltage tracking to other voltage rails and tolerate output capacitors ranging from 10 μF up to 150 μF and beyond. Using the DCS-Control™ topology, the devices achieve excellent load transient performance and accurate output voltage regulation.

The output voltage start-up ramp is controlled by the SS pin, which allows operation as either a standalone power supply or in tracking configurations. Power sequencing is also possible by configuring the enable and power good pins. In power save mode, the devices operate at typically 20- μA quiescent current. Power save mode is entered automatically and seamlessly maintaining high efficiency over the entire load current range.

Device Information

PART NUMBER	PACKAGE ⁽¹⁾	BODY SIZE (NOM)
TPS62090Q	QFN (16)	3.00 mm \times 3.00 mm

- (1) For all available packages, see the orderable addendum at the end of the data sheet.

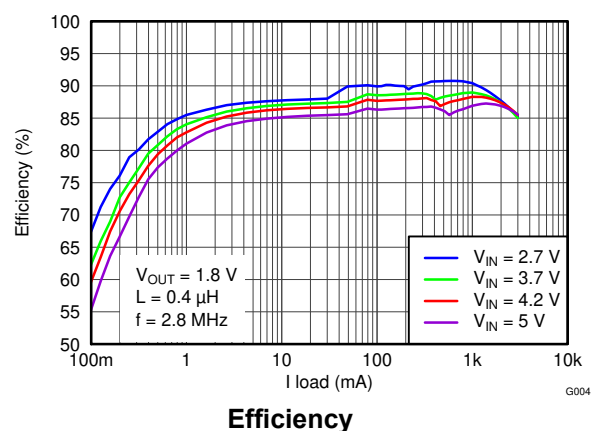

G004



Table of Contents

1 Features	1	8.1 Application Information.....	13
2 Applications	1	8.2 Typical Application.....	13
3 Description	1	8.3 System Examples.....	19
4 Revision History	2	9 Power Supply Recommendations	21
5 Pin Configuration and Functions	3	10 Layout	22
6 Specifications	4	10.1 Layout Guidelines.....	22
6.1 Absolute Maximum Ratings.....	4	10.2 Layout Example.....	22
6.2 ESD Ratings.....	4	11 Device and Documentation Support	23
6.3 Recommended Operating Conditions.....	4	11.1 Device Support.....	23
6.4 Thermal Information.....	4	11.2 Documentation Support.....	23
6.5 Electrical Characteristics.....	5	11.3 Receiving Notification of Documentation Updates..	23
6.6 Typical Characteristics.....	6	11.4 Support Resources.....	23
7 Detailed Description	8	11.5 Trademarks.....	23
7.1 Overview.....	8	11.6 Electrostatic Discharge Caution.....	23
7.2 Functional Block Diagram.....	8	11.7 Glossary.....	23
7.3 Feature Description.....	9	12 Mechanical, Packaging, and Orderable Information	23
7.4 Device Functional Modes.....	11		
8 Application and Implementation	13		

4 Revision History

NOTE: Page numbers for previous revisions may differ from page numbers in the current version.

Changes from Revision B (December 2016) to Revision C (November 2021) Page

- Updated the numbering format for tables, figures, and cross-references throughout the document. 1
- Added link to the TPS62813-Q1..... 1

Changes from Revision A (August 2013) to Revision B (December 2016) Page

- Added *Pin Configuration and Functions* section, *ESD Ratings* table, *Feature Description* section, *Device Functional Modes*, *Application and Implementation* section, *Power Supply Recommendations* section, *Layout* section, *Device and Documentation Support* section, and *Mechanical, Packaging, and Orderable Information* section..... 1
- Added CN and CP pin voltage..... 4
- Added typical value of V_H and V_L 5
- Added new graphs to the *Typical Characteristics* section 6
- Added Switching frequency curves for $V_{OUT} = 1\text{ V}$ and $V_{OUT} = 3.3\text{ V}$ 6
- Added *Enable and Disable (EN)* section..... 9
- Added Hiccup current limit during startup 9
- Added *Charge Pump (CP, CN)* section..... 11
- Updated *Input and Output Capacitor Selection* section..... 16
- Moved graphs from *Typical Characteristics* to *Application Curves* section 17
- Updated TPS62090Q Layout..... 22

5 Pin Configuration and Functions

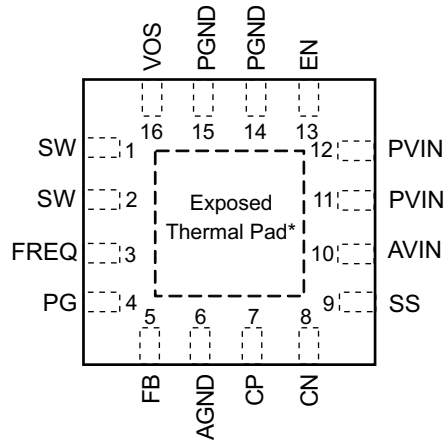

The exposed thermal pad is connected to AGND.

Figure 5-1. RGT Package 16-Pin QFN With Exposed Thermal Pad Top View

6 Specifications

6.1 Absolute Maximum Ratings

over operating free-air temperature range (unless otherwise noted)⁽¹⁾

		MIN	MAX	UNIT
Voltage ⁽²⁾	PVIN, AVIN, FB, SS, EN, FREQ, VOS	-0.3	7	V
	SW, PG	-0.3	$V_{IN} + 0.3$	
	CN, CP	-0.3	$V_{IN} + 7$	
Power Good sink current, PG			1	mA
Operating junction temperature, T_J		-40	150	°C
Storage temperature, T_{stg}		-65	150	°C

- (1) Stresses beyond those listed under *Absolute Maximum Ratings* may cause permanent damage to the device. These are stress ratings only, which do not imply functional operation of the device at these or any other conditions beyond those indicated under *Recommended Operating Conditions*. Exposure to absolute-maximum-rated conditions for extended periods may affect device reliability.
- (2) All voltage values are with respect to network ground terminal.

6.2 ESD Ratings

		VALUE	UNIT
$V_{(ESD)}$	Electrostatic discharge	Human-body model (HBM), per AEC Q100-002 ⁽¹⁾	±2500
		Charged-device model (CDM), per AEC Q100-011	±1500

- (1) AEC Q100-002 indicates that HBM stressing shall be in accordance with the ANSI/ESDA/JEDEC JS-001 specification.

6.3 Recommended Operating Conditions

For additional information, see [Section 8.1](#).

		MIN	MAX	UNIT
V_{IN}	Input voltage	2.5	6	V
T_J	Operating junction temperature	-40	125	°C

6.4 Thermal Information

THERMAL METRIC ⁽¹⁾		TPS62090-Q1	UNIT
		RGT (QFN)	
		16 PINS	
$R_{\theta JA}$	Junction-to-ambient thermal resistance	45.6	°C/W
$R_{\theta JC(top)}$	Junction-to-case (top) thermal resistance	58.9	°C/W
$R_{\theta JB}$	Junction-to-board thermal resistance	19	°C/W
Ψ_{JT}	Junction-to-top characterization parameter	1.1	°C/W
Ψ_{JB}	Junction-to-board characterization parameter	19	°C/W
$R_{\theta JC(bot)}$	Junction-to-case (bottom) thermal resistance	4	°C/W

- (1) For more information about traditional and new thermal metrics, see the [Semiconductor and IC Package Thermal Metrics](#) application report.

6.5 Electrical Characteristics

$V_{IN} = 3.6\text{ V}$, $T_J = -40^\circ\text{C}$ to 125°C , typical values are at $T_J = 25^\circ\text{C}$ (unless otherwise noted)

PARAMETER		TEST CONDITIONS	MIN	TYP	MAX	UNIT
SUPPLY						
V_{IN}	Input voltage range		2.5		6	V
I_{QIN}	Quiescent current	Not switching, FB = FB +5 %, Into PVIN and AVIN		20		μA
I_{sd}	Shutdown current	Into PVIN and AVIN		0.6	5	μA
UVLO	Undervoltage lockout threshold	V_{IN} falling	2.1	2.2	2.3	V
	Undervoltage lockout hysteresis			200		mV
	Thermal shutdown	Temperature rising		150		$^\circ\text{C}$
	Thermal shutdown hysteresis			20		$^\circ\text{C}$
CONTROL SIGNALS EN, FREQ						
V_H	High level input voltage	$V_{IN} = 2.5$ to 6 V	1	0.65		V
V_L	Low level input voltage	$V_{IN} = 2.5$ to 6 V		0.6	0.4	V
I_{lkG}	Input leakage current	EN, FREQ = GND or V_{IN}		10	100	nA
R_{PD}	Pulldown resistance			400		k Ω
SOFT START						
I_{SS}	Soft-start current		6.3	7.5	8.7	μA
POWER GOOD						
V_{th}	Power good threshold	Output voltage rising		95%		
		Output voltage falling		90%		
V_L	Low level voltage	$I_{(sink)} = 1\text{ mA}$			0.4	V
I_{PG}	PG sinking current				1	mA
I_{lkG}	Leakage current	$V_{PG} = 3.6\text{ V}$		10	200	nA
POWER SWITCH						
$R_{DS(on)}$	High-side FET on-resistance	$I_{SW} = 500\text{ mA}$		50		m Ω
	Low-side FET on-resistance	$I_{SW} = 500\text{ mA}$		40		m Ω
I_{LIM}	High-side FET switch current limit		3.7	4.6	5.5	A
f_s	Switching frequency	FREQ = GND, $I_{OUT} = 3\text{ A}$		2.8		MHz
		FREQ = VIN, $I_{OUT} = 3\text{ A}$		1.4		MHz
OUTPUT						
V_s	Output voltage		0.8		V_{IN}	V
R_{od}	Output discharge resistor	EN = GND, $V_{OUT} = 1.8\text{ V}$		200		Ω
V_{FB}	Feedback regulation voltage			0.8		V
V_{FB}	Feedback voltage accuracy ^{(1) (2)}	$V_{IN} \geq V_{OUT} + 1\text{ V}$	$I_{OUT} = 1\text{ A}$, PWM mode	-1.4%	1.4%	
			$I_{OUT} = 0\text{ mA}$, FREQ = 2.8 MHz, $V_{OUT} \geq 0.8\text{ V}$, PFM mode	-1.4%	3%	
			$I_{OUT} = 0\text{ mA}$, FREQ = 1.4 MHz, $V_{OUT} \geq 1.2\text{ V}$, PFM mode	-1.4%	3%	
			$I_{OUT} = 0\text{ mA}$, FREQ = 1.4 MHz, $V_{OUT} < 1.2\text{ V}$, PFM mode	-1.4%	3.7%	
I_{FB}	Feedback input bias current	$V_{FB} = 0.8\text{ V}$		10	100	nA
V_{OUT}	Output voltage accuracy ⁽²⁾	$V_{IN} \geq V_{OUT} + 1\text{ V}$, fixed output voltage, $f = 2.8\text{ MHz}$, $L = 0.47\text{ }\mu\text{H}$, $C_{OUT} = 22\text{ }\mu\text{F}$ or $f = 1.4\text{ MHz}$, $L = 1\text{ }\mu\text{H}$, $C_{OUT} = 22\text{ }\mu\text{F}$	$I_{OUT} = 1\text{ A}$, PWM mode	-1.4%	1.4%	
			$I_{OUT} = 0\text{ mA}$, FREQ = high and low, PFM mode	-1.4%	2.5%	
	Line regulation	$V_{OUT} = 1.8\text{ V}$, PWM operation		0.016%		V
	Load regulation	$V_{OUT} = 1.8\text{ V}$, PWM operation		0.04%		A

(1) For output voltages < 1.2 V, use a $2 \times 22\text{ }\mu\text{F}$ output capacitance to achieve 3% output voltage accuracy.

(2) For more information, see [Section 7.4.2](#).

6.6 Typical Characteristics

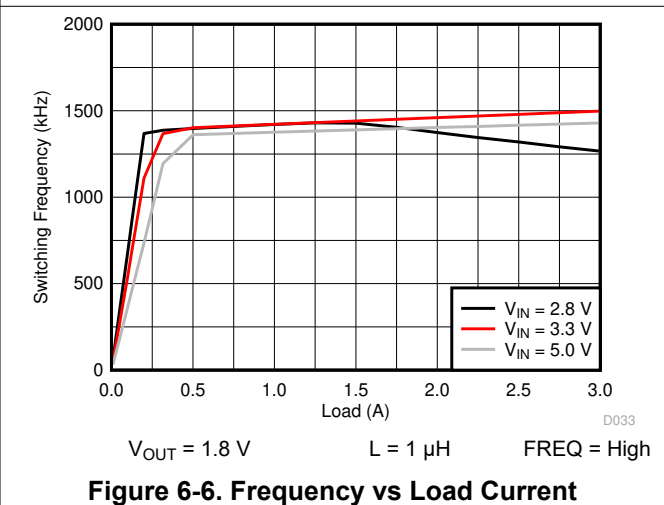
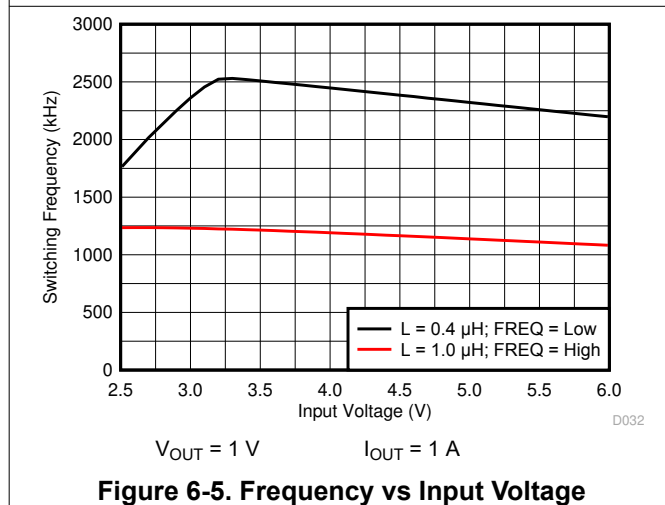
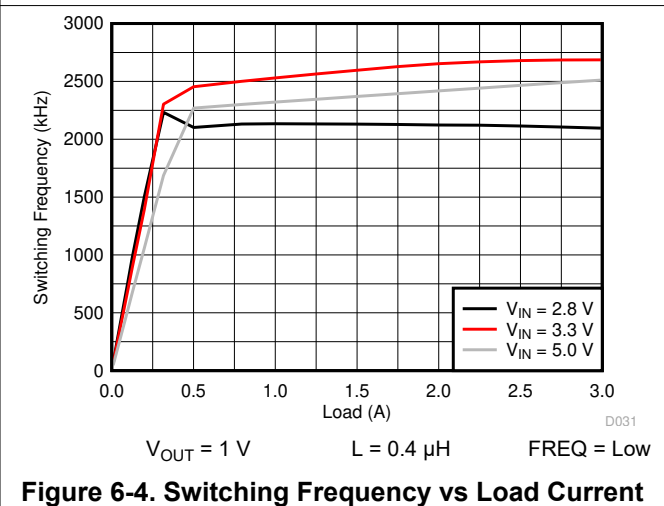
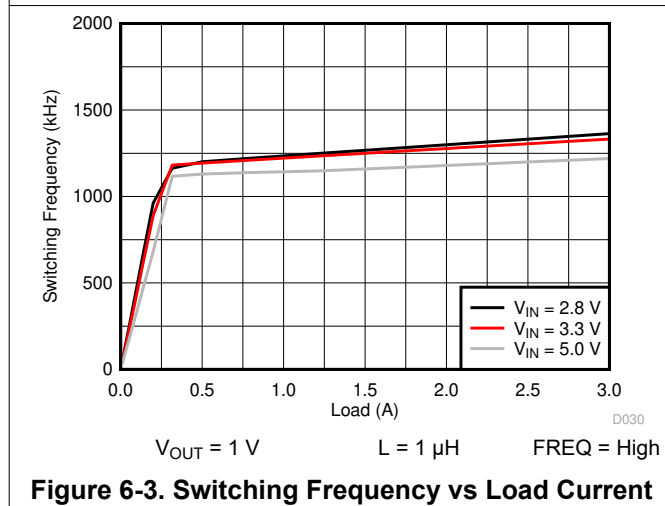
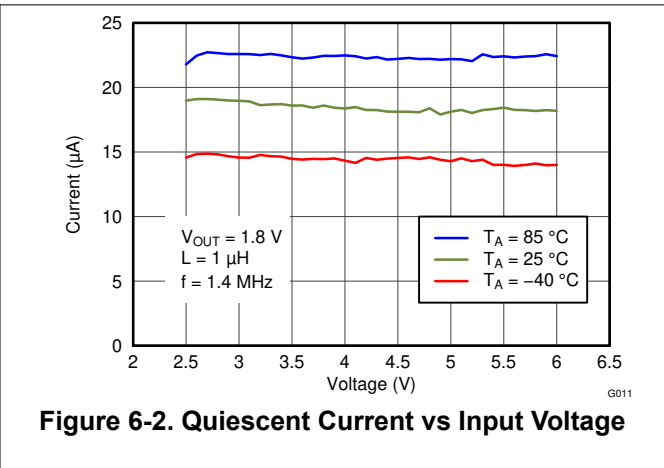
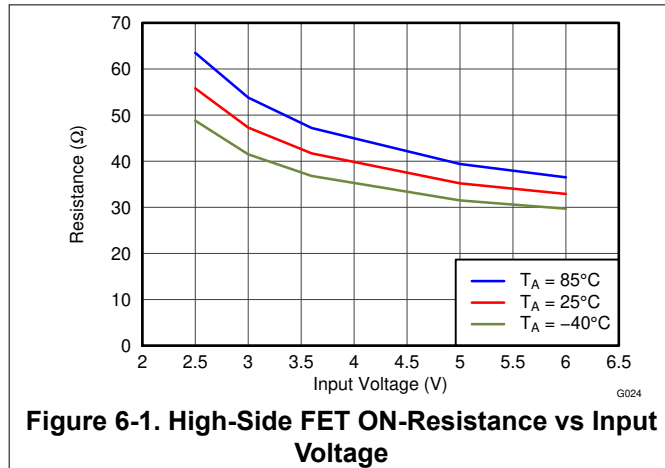

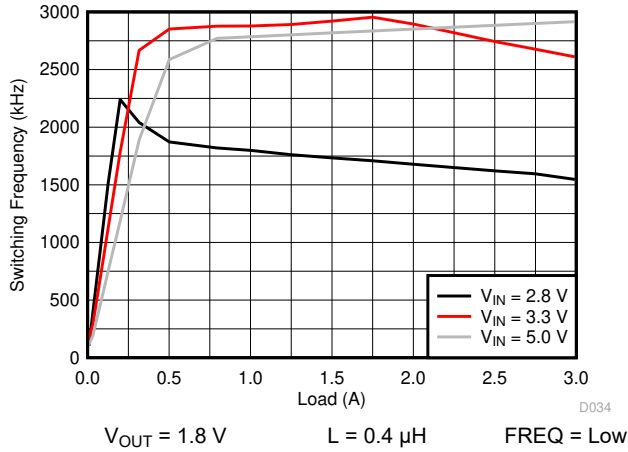

Figure 6-7. Frequency vs Load Current

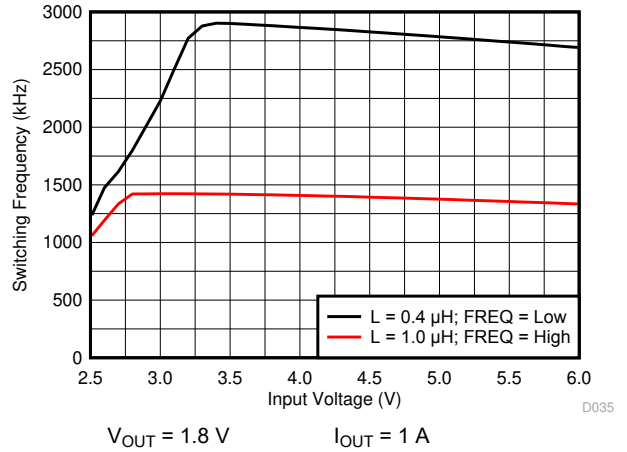

Figure 6-8. Frequency vs Input Voltage

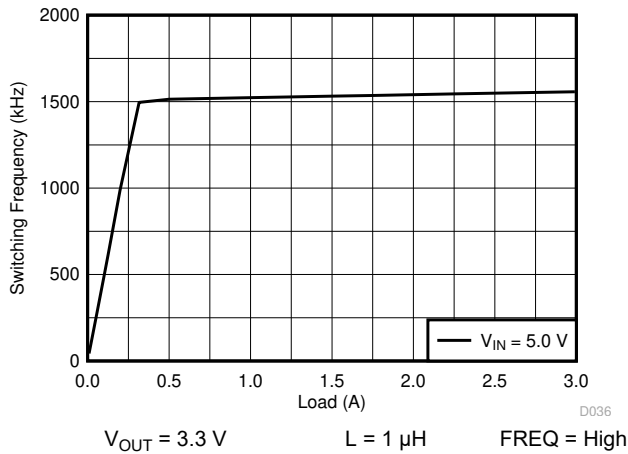

Figure 6-9. Frequency vs Load Current

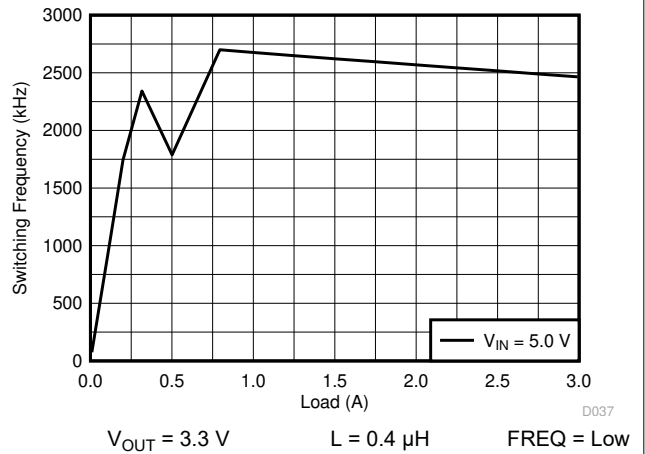

Figure 6-10. Frequency vs Load Current

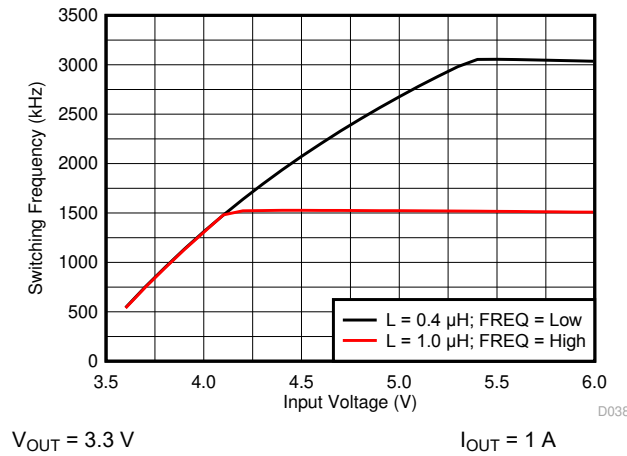

Figure 6-11. Frequency vs Input Voltage

7 Detailed Description

7.1 Overview

The TPS62090Q synchronous switched mode converter is based on DCS-Control (Direct Control with Seamless transition into power save mode). DCS-Control is an advanced regulation topology that combines the advantages of hysteretic and voltage mode control.

The DCS-Control topology operates in Pulse Width Modulation (PWM) mode for medium to heavy load conditions and in power save mode at light load currents. In PWM, the converter operates with nominal switching frequency of 2.8 MHz or 1.4 MHz, having a controlled frequency variation over the input voltage range. As the load current decreases, the converter enters power save mode, reducing the switching frequency and minimizing the IC quiescent current to achieve high efficiency over the entire load current range. DCS-Control supports both operation modes (PWM and PFM) using a single building block with a seamless transition from PWM to power save mode without effecting the output voltage. The TPS62090Q device offers excellent DC-voltage regulation and load transient regulation, combined with low output voltage ripple, to minimize interference with RF circuits.

7.2 Functional Block Diagram

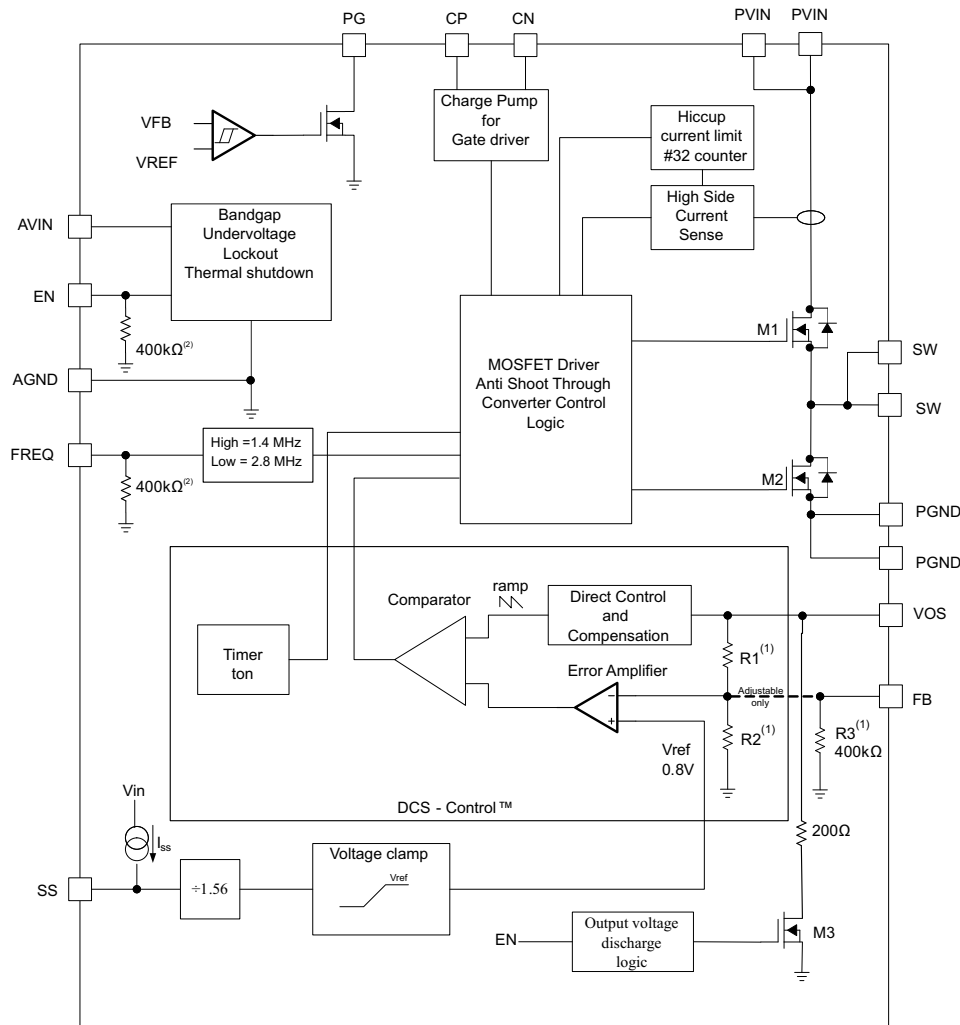

Copyright © 2016, Texas Instruments Incorporated

(2) The resistors are disconnected when the pins are high.

7.3 Feature Description

7.3.1 Enable and Disable (EN)

The device is enabled by setting the EN pin to a logic high. Accordingly, shutdown mode is forced if the EN pin is pulled low with a shutdown current of typically 0.6 μA . In shutdown mode, the internal power switches as well as the entire control circuitry are turned off. An internal resistor of 200 Ω discharges the output through the VOS pin smoothly. An internal pulldown resistor of 400 k Ω is connected to the EN pin when the EN pin is low. The pulldown resistor is disconnected when the EN pin is high.

7.3.2 Soft Start (SS) and Hiccup Current Limit During Start-Up

To minimize inrush current during start-up, the device has an adjustable soft start depending on the capacitor value connected to the SS pin. The device charges the soft-start capacitor with a constant current of typically 7.5 μA . The feedback voltage follows this voltage with a fraction of 1.56 until the internal reference voltage of 0.8 V is reached. The soft-start operation is complete when the voltage at the soft-start capacitor has reached typically 1.25 V. The soft-start time is calculated using [Equation 1](#). The larger the soft-start capacitor, the longer the soft-start time. The relation between soft-start voltage and feedback voltage is estimated using [Equation 2](#).

$$t_{\text{SS}} = C_{\text{SS}} \times \frac{1.25\text{V}}{7.5\mu\text{A}} \quad (1)$$

$$V_{\text{FB}} = \frac{V_{\text{SS}}}{1.56} \quad (2)$$

During start-up, the switch current limit is reduced to 1/3 (approximately 1.5 A) of its typical current limit of 4.6 A. Once the output voltage exceeds typically 0.6 V, the current limit is released to its nominal value. The device provides a reduced load current of approximately 1.5 A when the output voltage is below typically 0.6 V. Due to this, a small or no soft-start time may trigger the short-circuit protection during start-up especially for larger output capacitors. This is avoided by using a larger soft-start capacitance to extend the soft-start time. See [Section 7.3.4](#) for details of the reduced current limit during start-up. Leaving the soft-start pin floating sets the minimum start-up time (around 50 μs).

7.3.3 Voltage Tracking (SS)

The SS pin is externally driven by another voltage source to achieve output voltage tracking. The application circuit is shown in [Figure 7-1](#). The internal reference voltage follows the voltage at the SS pin with a fraction of 1.56 until the internal reference voltage of 0.8 V is reached. The device achieves ratiometric or coincidental (simultaneous) output tracking, as shown in [Figure 7-2](#).

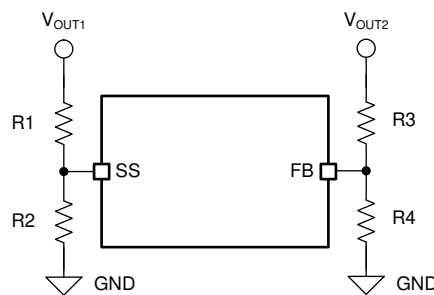

Copyright © 2017, Texas Instruments Incorporated

Figure 7-1. Output Voltage Tracking

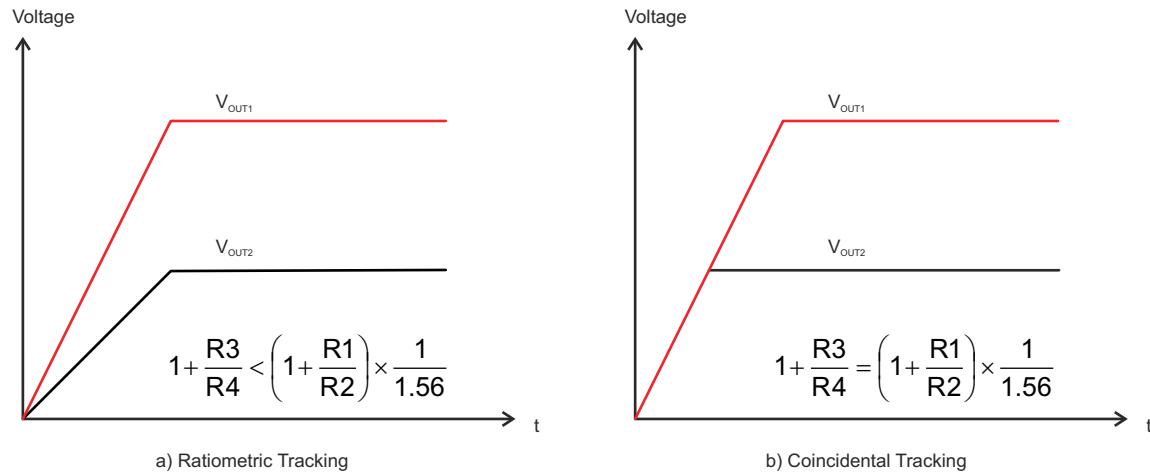

Figure 7-2. Voltage Tracking Options

The R2 value should be set properly to achieve accurate voltage tracking by taking 7.5- μ A soft start-up current into account. 1 k Ω or smaller is a sufficient value for R2.

For decreasing the SS pin voltage, the device does not sink current from the output when the device is in power save mode. So the resulting decreases of the output voltage may be slower than the SS pin voltage if the load is light. When driving the SS pin with an external voltage, do not exceed the voltage rating of the SS pin which is 7 V.

7.3.4 Short-Circuit Protection (Hiccup Mode)

The device is protected against hard short circuits to GND and overcurrent events. This protection is implemented by a two-level short-circuit protection. During start-up and when the output is shorted to GND, the switch current limit is reduced to 1/3 of the typical current limit of 4.6 A. When the output voltage exceeds typically 0.6 V, the current limit is released to the nominal value. The full current limit is implemented as a hiccup current limit. Once the internal current limits are triggered 32 times, the device stops switching and starts a new start-up sequence after a typical delay time of 66 μ S passed by. The device continues in this cycle until the high current condition is released.

7.3.5 Output Discharge Function

To ensure the device starts up under the defined conditions, the output discharges through the VOS pin with a typical discharge resistor of 200 Ω whenever the device shuts down. This discharge happens when the device is disabled or if thermal shutdown, undervoltage lockout or short-circuit hiccup mode is triggered.

7.3.6 Power Good Output (PG)

The power good output is low when the output voltage is below the nominal value. The power good becomes high impedance once the output is within 5% of regulation. The PG pin is an open-drain output and is specified to typically sink up to 1 mA. This output requires a pullup resistor to be monitored properly. The pullup resistor cannot be connected to any voltage higher than the input voltage of the device. The PG output is low when the device is disabled, in thermal shutdown, or in UVLO. The PG output can be left floating if unused.

7.3.7 Frequency Set Pin (FREQ)

The FREQ pin is a digital logic input which sets the nominal switching frequency. Pulling this pin to GND sets the nominal switching frequency to 2.8 MHz and pulling this pin high sets the nominal switching frequency to 1.4 MHz. Because this pin changes the switching frequency, it also changes the on-time during PFM mode. At 1.4 MHz the on-time is twice the on-time as operating at 2.8 MHz. This pin has an active pulldown resistor of typically 400 k Ω . For applications where efficiency is of highest importance, a lower switching frequency should be selected. A higher switching frequency allows the use of smaller external components, faster load transient response, and lower output voltage ripple when using same L-C values.

7.3.8 Undervoltage Lockout (UVLO)

To avoid mis-operation of the device at low input voltages, an undervoltage lockout is included. UVLO shuts down the device at input voltages lower than typically 2.2 V with a 200-mV hysteresis.

7.3.9 Thermal Shutdown

The device enters thermal shutdown once the junction temperature exceeds typically 150°C with a 20°C hysteresis.

7.3.10 Charge Pump (CP, CN)

The CP and CN pins must attach to an external 10-nF capacitor to complete a charge pump for the gate driver. This capacitor must be rated for the input voltage. TI does not recommend connecting any other circuits to the CP or CN pins.

7.4 Device Functional Modes

7.4.1 Pulse Width Modulation Operation

At medium to heavy load currents, the device operates with PWM at a nominal switching frequency of 2.8 MHz or 1.4 MHz depending on the setting of the FREQ pin. As the load current decreases, the converter enters the power save mode operation reducing the switching frequency. The device enters power save mode at the boundary to discontinuous conduction mode (DCM).

7.4.2 Power Save Mode Operation

As the load current decreases, the converter enters power save mode operation. During power save mode, the converter operates with reduced switching frequency in PFM mode and with a minimum quiescent current while maintaining high efficiency. The power save mode is based on a fixed on-time architecture following Equation 3. When operating at 1.4 MHz, the on-time is twice as long as the on-time for 2.8-MHz operation, resulting in larger output voltage ripple, as shown in Figure 8-11 and Figure 8-12, and slightly higher output voltage at no load, as shown in Figure 8-8 and Figure 8-9. To have the same output voltage ripple at 1.4 MHz during PFM mode, either the output capacitor or the inductor value must be increased. As an example, operating at 2.8 MHz using 0.47-μH inductor gives the same output voltage ripple as operating with 1.4 MHz using 1-μH inductor.

$$\begin{aligned}
 t_{on_{2.8\text{MHz}}} &= \frac{V_{\text{OUT}}}{V_{\text{IN}}} \times 360\text{ns} \\
 t_{on_{1.4\text{MHz}}} &= \frac{V_{\text{OUT}}}{V_{\text{IN}}} \times 360\text{ns} \times 2 \\
 f &= \frac{2 \times I_{\text{OUT}}}{t_{on}^2 \left(1 + \frac{V_{\text{IN}} - V_{\text{OUT}}}{V_{\text{OUT}}} \right) \times \frac{V_{\text{IN}} - V_{\text{OUT}}}{L}}
 \end{aligned} \tag{3}$$

In power save mode the output voltage rises slightly above the nominal output voltage in PWM mode, as shown in Figure 8-8 and Figure 8-9. This effect is reduced by increasing the output capacitance or the inductor value. This effect is also reduced by programming the output voltage of the TPS62090Q lower than the target value. As an example, if the target output voltage is 3.3 V, then the TPS62090Q is programmed to 3.3 V – 0.8%. As a result the output voltage accuracy is now –2.2% to +2.2% instead of –1.4% to 3%. The output voltage accuracy in PFM operation is reflected in the Section 6.5 table and given for a 22-μF output capacitance.

7.4.3 Low-Dropout Operation (100% Duty Cycle)

The device offers low input to output voltage difference by entering 100% duty cycle mode. In this mode the high-side MOSFET switch is constantly turned on which is particularly useful in battery-powered applications to achieve longest operation time by taking full advantage of the whole battery voltage range. The minimum input voltage where the output voltage falls below the nominal regulation value is given by Equation 4.

$$V_{\text{IN (min)}} = V_{\text{OUT}} + I_{\text{OUT}} \times (R_{\text{DS(on)}} + R_{\text{L}}) \tag{4}$$

Where

- $R_{DS(on)}$ = High side FET on-resistance
- R_L = DC resistance of the inductor

8 Application and Implementation

Note

Information in the following applications sections is not part of the TI component specification, and TI does not warrant its accuracy or completeness. TI's customers are responsible for determining suitability of components for their purposes, as well as validating and testing their design implementation to confirm system functionality.

8.1 Application Information

The TPS62090-Q1 device is a high-frequency, synchronous, step-down converter optimized for small solution size, high efficiency, and is suitable for battery-powered applications.

8.2 Typical Application

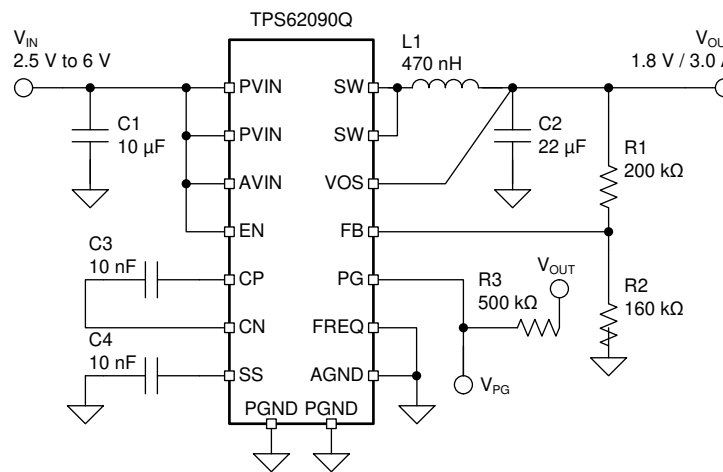

Copyright © 2016, Texas Instruments Incorporated

Figure 8-1. Test Circuit

8.2.1 Design Requirements

Table 8-1 is a recommended list of components for the test circuit in Figure 8-1.

Table 8-1. List of Components

REFERENCE	DESCRIPTION	MANUFACTURER
TPS62090Q	High efficiency step-down converter	Texas Instruments
L1	Inductor: 1 µH, 0.47 µH, 0.4 µH	Coilcraft XFL4020-102, XAL4020-401, TOKO DEF252012-R47
C1	Ceramic capacitor: 10 µF, 22 µF	(6.3-V, X5R, 0603), (6.3-V, X5R, 0805)
C2	Ceramic capacitor: 22 µF	(6.3-V, X5R, 0805)
C3, C4	Ceramic capacitor	Standard
R1, R2, R3	Resistor	Standard

8.2.2 Detailed Design Procedure

The first step in the design procedure is the selection of the output filter components. To simplify this process, [Table 8-2](#) and [Table 8-3](#) list possible inductor and capacitor value combinations.

Table 8-2. Output Filter Selection (2.8-MHz Operation, FREQ = GND)

INDUCTOR VALUE (μH) ⁽³⁾	OUTPUT CAPACITOR VALUE (μF) ⁽²⁾				
	10	22	47	100	150
0.47	—	√ ⁽¹⁾	√	√	√
1	√	√	√	√	√
2.2	—	—	—	—	—
3.3	—	—	—	—	—

- (1) Typical application configuration. Other check marks indicate alternative filter combinations.
- (2) Capacitance tolerance and bias voltage de-rating is anticipated. The effective capacitance varies by +20% and –50%.
- (3) Inductor tolerance and current de-rating is anticipated. The effective inductance varies by +20% and –30%.

Table 8-3. Output Filter Selection (1.4-MHz Operation, FREQ = V_{IN})

INDUCTOR VALUE (μH) ⁽³⁾	OUTPUT CAPACITOR VALUE (μF) ⁽²⁾				
	10	22	47	100	150
0.47	—	√	√	√	√
1	√	√ ⁽¹⁾	√	√	√
2.2	√	√	√	√	√
3.3	—	—	—	—	—

- (1) Typical application configuration. Other check marks indicate alternative filter combinations.
- (2) Capacitance tolerance and bias voltage de-rating is anticipated. The effective capacitance varies by +20% and –50%.
- (3) Inductor tolerance and current de-rating is anticipated. The effective inductance varies by +20% and –30%.

8.2.2.1 Inductor Selection

The inductor selection is affected by several parameters such as inductor-ripple current, output-voltage ripple, transition point into power save mode, and efficiency. See [Table 8-4](#) for typical inductors.

Table 8-4. Inductor Selection

INDUCTOR VALUE	COMPONENT SUPPLIER	SIZE (L × W × H mm)	Isat / DCR
0.6 μH	Coilcraft XAL4012-601	4 × 4 × 2.1	7.1 A / 9.5 m Ω
1 μH	Coilcraft XAL4020-102	4 × 4 × 2.1	5.9 A / 13.2 m Ω
1 μH	Coilcraft XFL4020-102	4 × 4 × 2.1	5.1 A / 10.8 m Ω
0.47 μH	TOKO DFE252012 R47	2.5 × 2 × 1.2	3.7 A / 39 m Ω
1 μH	TOKO DFE252012 1R0	2.5 × 2 × 1.2	3.0 A / 59 m Ω
0.68 μH	TOKO DFE322512 R68	3.2 × 2.5 × 1.2	3.5 A / 37 m Ω
1 μH	TOKO DFE322512 1R0	3.2 × 2.5 × 1.2	3.1 A / 45 m Ω

In addition, the inductor must be rated for the appropriate saturation current and DC resistance (DCR). The inductor must be rated for a saturation current as high as the typical switch current limit, of 4.6 A or according to [Equation 5](#) and [Equation 6](#). [Equation 5](#) and [Equation 6](#) calculate the maximum inductor current under static load conditions. The formula takes the converter efficiency into account. The converter efficiency is taken from the [Section 6.6](#) graphs or 80% can be used as a conservative approach. The calculation must be done for the maximum input voltage where the peak switch current is highest.

$$I_L = I_{OUT} + \frac{\Delta I_L}{2} \quad (5)$$

$$I_L = I_{OUT} + \frac{V_{OUT}}{\eta} \times \left(1 - \frac{V_{OUT}}{V_{IN} \times \eta}\right) \quad (6)$$

where

- f = Converter switching frequency (typical 2.8 MHz or 1.4 MHz)
- L = Selected inductor value
- η = Estimated converter efficiency (use the number from the efficiency curves or 0.80 as a conservative assumption)

Note

The calculation must be done for the maximum input voltage of the application

Calculating the maximum inductor current using the actual operating conditions gives the minimum saturation current. A margin of 20% must be added to cover for load transients during operation.

8.2.2.2 Input and Output Capacitor Selection

For best output and input voltage filtering, low-ESR (X5R or X7R) ceramic capacitors are recommended. The input capacitor minimizes input voltage ripple, suppresses input voltage spikes and provides a stable system rail for the device. A 10- μ F or larger input capacitor is recommended when $FREQ = Low$ and a 22- μ F or larger when $FREQ = High$.

The output capacitor value can range from 10 μ F up to 150 μ F and beyond. Load transient testing and measuring the bode plot are good ways to verify stability with larger capacitor values. The recommended typical output capacitor value is 22 μ F (nominal) and can vary over a wide range as outline in the output filter selection table. For output voltages above 1.8 V, noise can cause duty cycle jitter. This does not degrade device performance. Using an output capacitor of $2 \times 22 \mu$ F (nominal) for output voltages >1.8 V avoids duty cycle jitter.

Ceramic capacitor have a DC-Bias effect, which has a strong influence on the final effective capacitance. Choose the right capacitor carefully in combination with considering its package size and voltage rating.

8.2.2.3 Setting the Output Voltage

The output voltage is set by an external resistor divider according to [Equation 7](#), [Equation 8](#), and [Equation 9](#).

$$V_{OUT} = V_{FB} \times \left(1 + \frac{R1}{R2}\right) = 0.8 \text{ V} \times \left(1 + \frac{R1}{R2}\right) \quad (7)$$

$$R2 = \frac{V_{FB}}{I_{FB}} = \frac{0.8 \text{ V}}{5 \mu\text{A}} \approx 160 \text{ k}\Omega \quad (8)$$

$$R1 = R2 \times \left(\frac{V_{OUT}}{V_{FB}} - 1\right) = R2 \times \left(\frac{V_{OUT}}{0.8\text{V}} - 1\right) \quad (9)$$

When sizing $R2$, use a minimum of 5 μ A for the feedback current (I_{FB}) to achieve low quiescent current and acceptable noise sensitivity. Larger currents through $R2$ improve noise sensitivity and output voltage accuracy. A feed-forward capacitor is not required for proper operation.

8.2.3 Application Curves

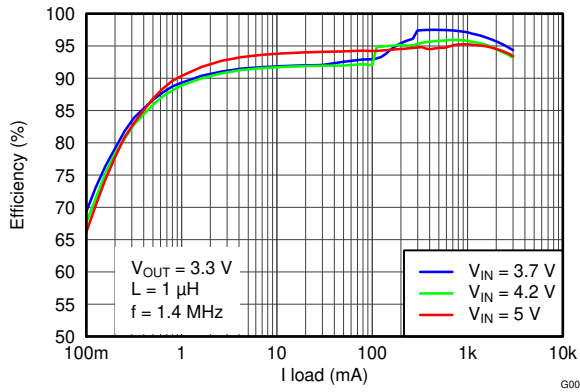

Figure 8-2. Efficiency vs Load Current

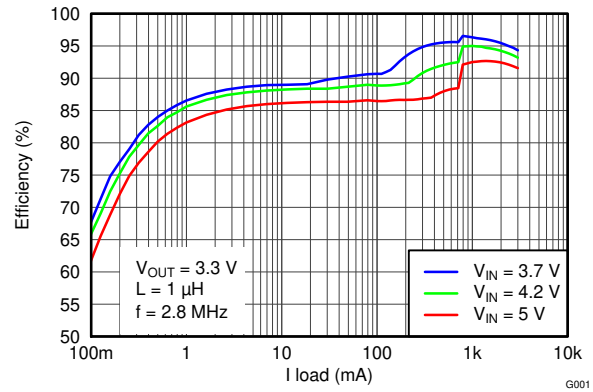

Figure 8-3. Efficiency vs Load Current

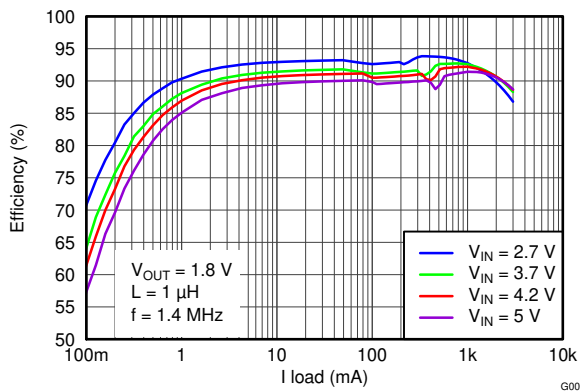

Figure 8-4. Efficiency vs Load Current

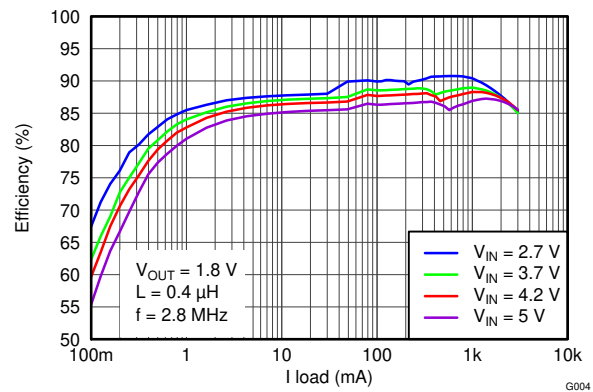

Figure 8-5. Efficiency vs Load Current

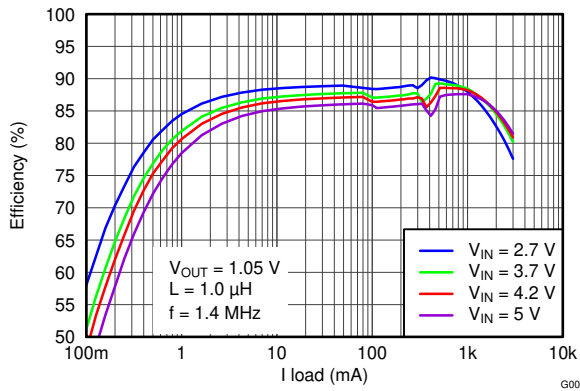

Figure 8-6. Efficiency vs Load Current

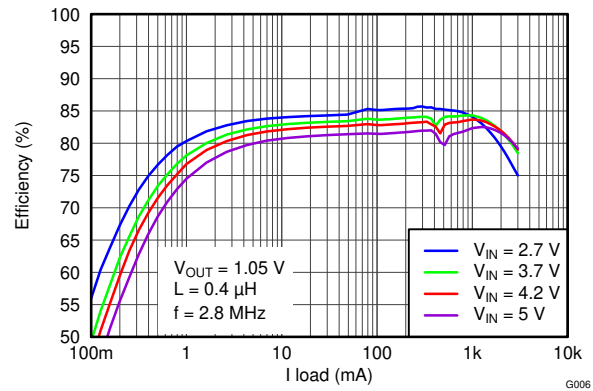

Figure 8-7. Efficiency vs Load Current

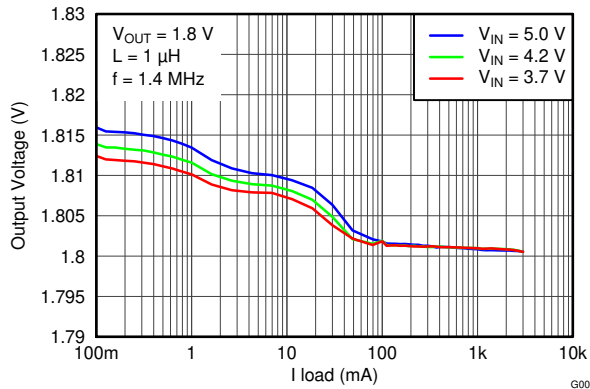

Figure 8-8. Output Voltage vs Load Current

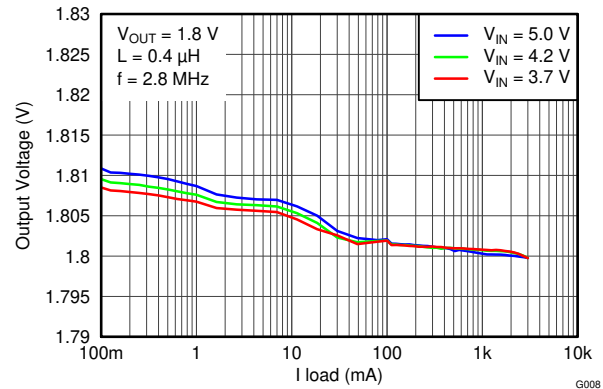

Figure 8-9. Output Voltage vs Load Current

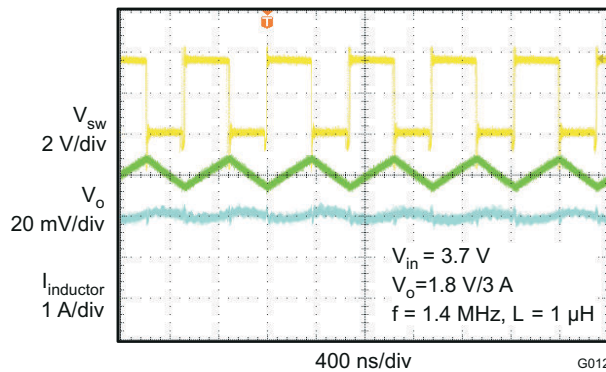

Figure 8-10. PWM Operation

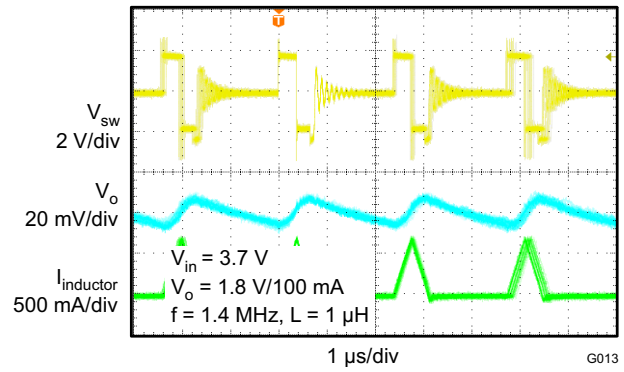

Figure 8-11. PFM Operation

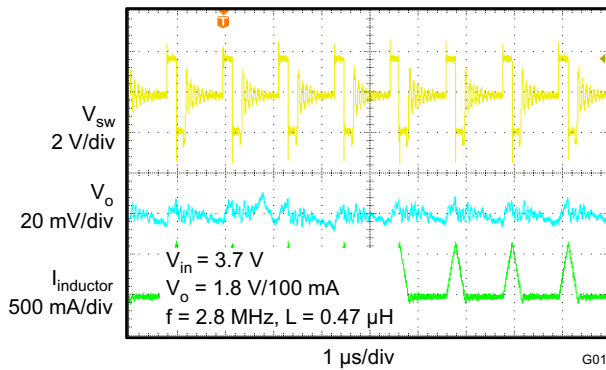

Figure 8-12. PFM Operation

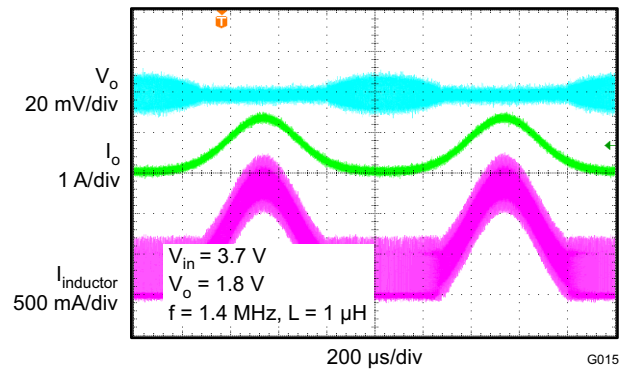

Figure 8-13. Load Sweep

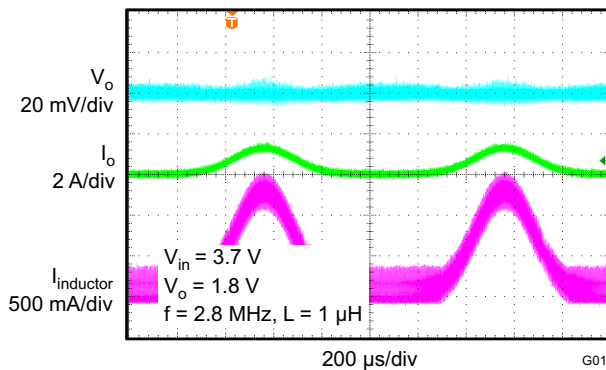

Figure 8-14. Load Sweep

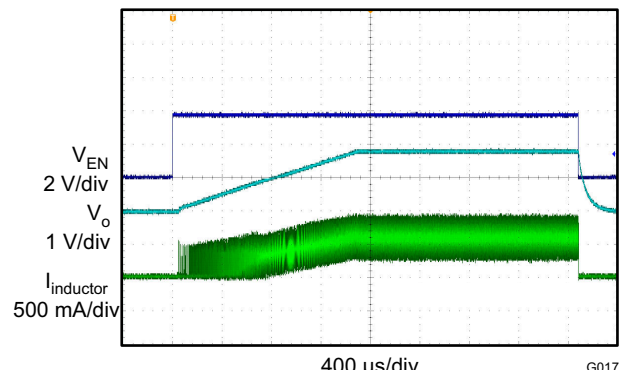

Figure 8-15. Start-Up

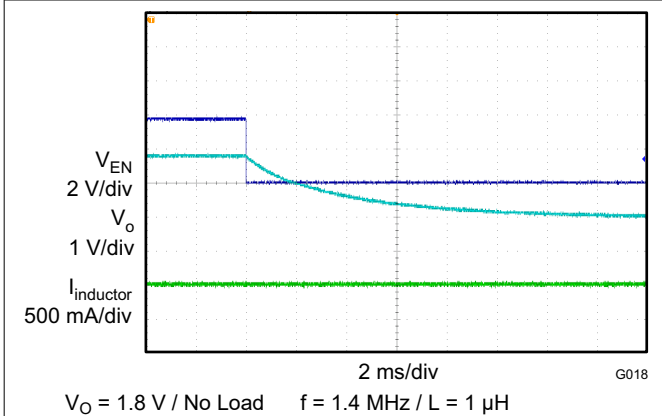

Figure 8-16. Shutdown

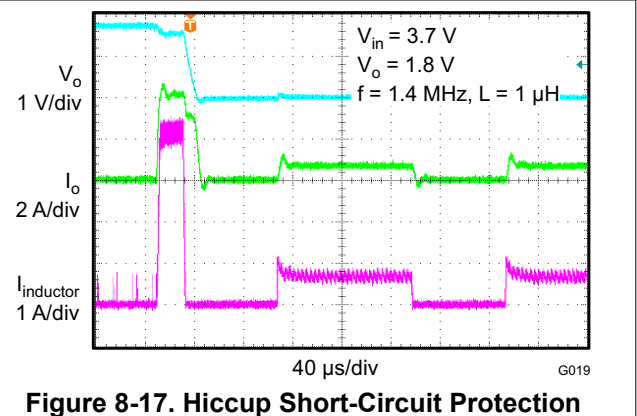

Figure 8-17. Hiccup Short-Circuit Protection

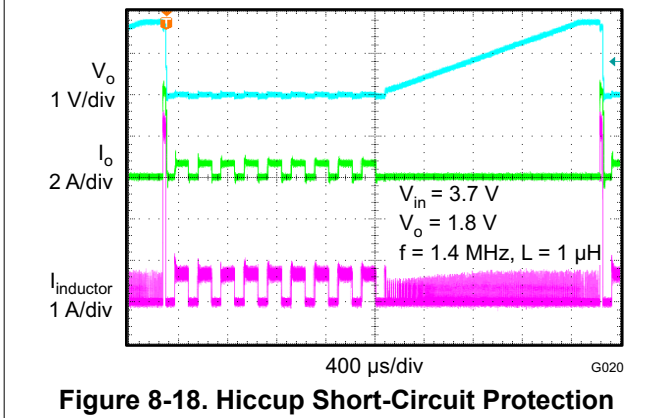

Figure 8-18. Hiccup Short-Circuit Protection

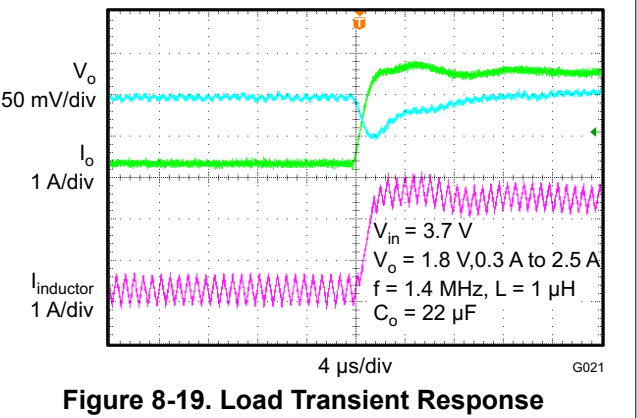

Figure 8-19. Load Transient Response

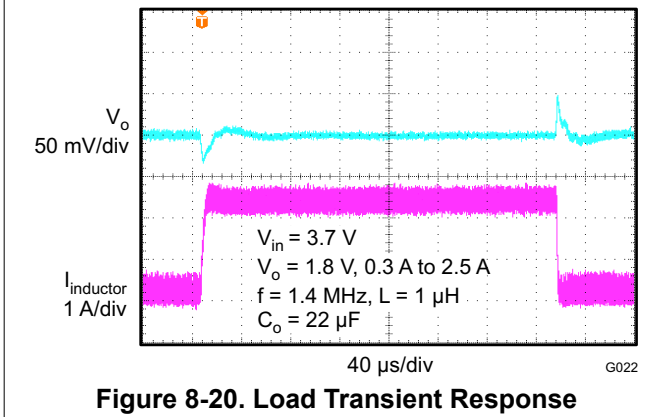

Figure 8-20. Load Transient Response

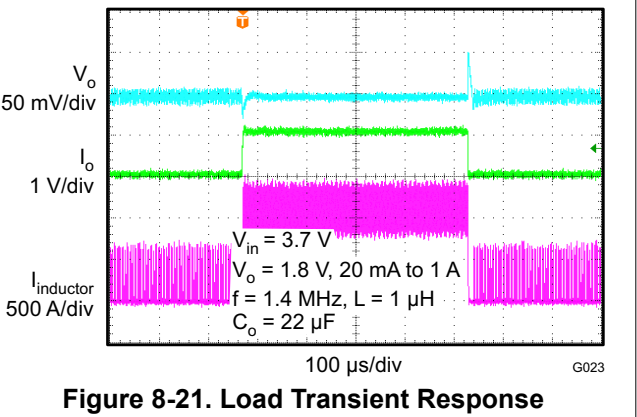
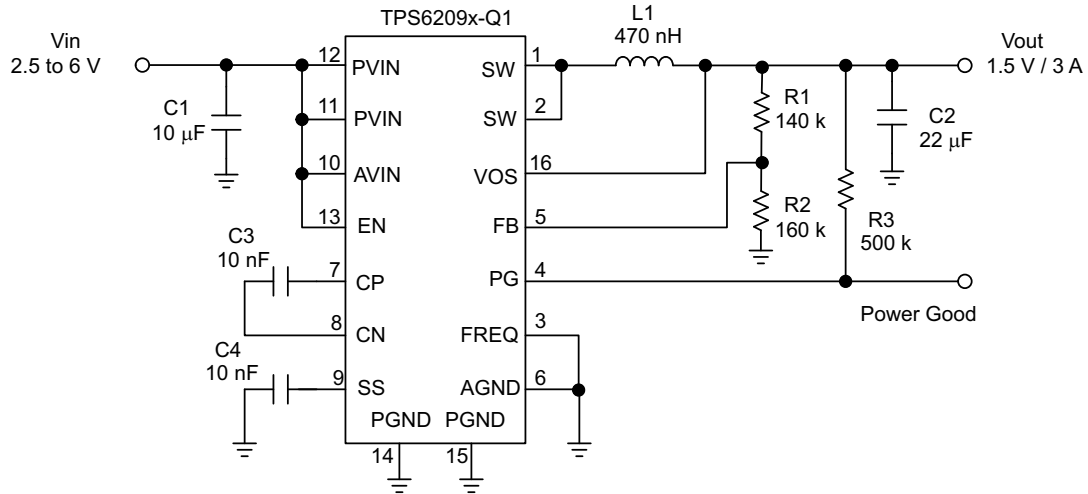

Figure 8-21. Load Transient Response

8.3 System Examples

Figure 8-22, Figure 8-23, and Figure 8-24 show additional circuits for varying voltage options.



Copyright © 2016, Texas Instruments Incorporated

Figure 8-22. 1.5-V Adjustable Version Operating at 2.8 MHz

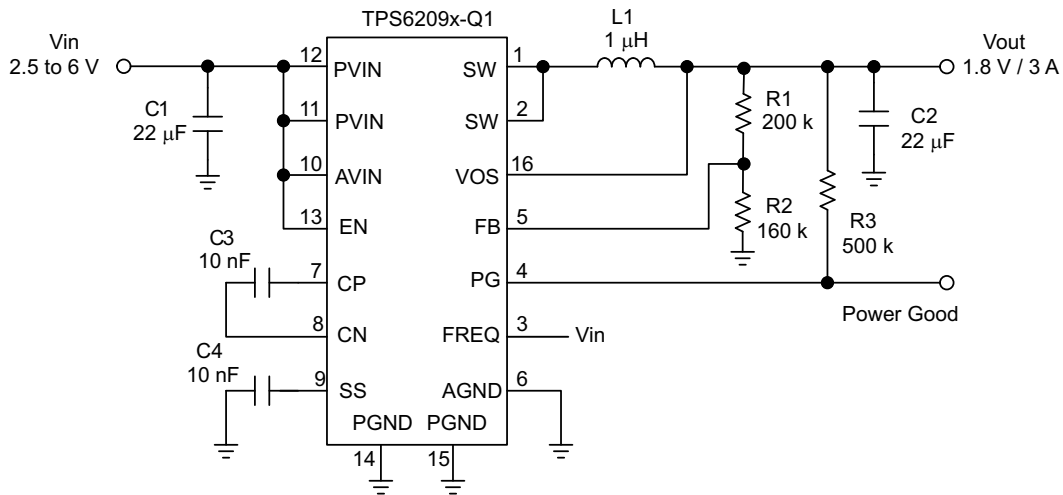

Copyright © 2016, Texas Instruments Incorporated

Figure 8-23. 1.8-V Adjustable Version Operating at 1.4 MHz

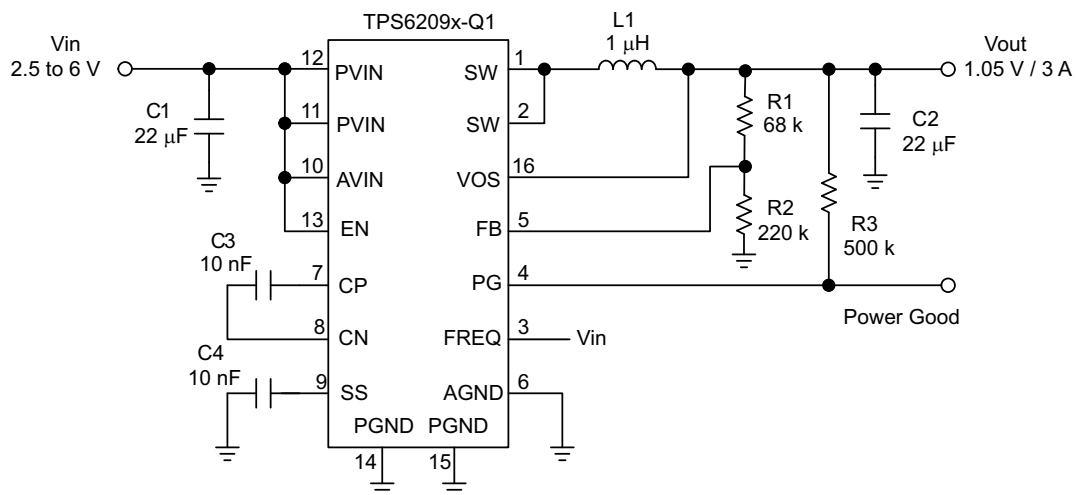

Copyright © 2016, Texas Instruments Incorporated

Figure 8-24. 1.05-V Adjustable Version Operating at 1.4 MHz

9 Power Supply Recommendations

The power supply to the TPS62090-Q1 device must have a current rating according to the supply voltage, output voltage, and output current of the TPS62090-Q1 device.

10 Layout

10.1 Layout Guidelines

- TI recommends placing the input capacitor as close as possible to the IC pins PVIN and PGND.
- The VOS connection is noise sensitive and needs to be routed as short and directly to the output pin of the inductor.
- The exposed thermal pad of the package, analog ground (pin 6) and power ground (pin 14, 15) should have a single joint connection at the exposed thermal pad of the package. This minimizes switch node jitter.
- The charge pump capacitor connected to CP and CN should be placed close to the IC to minimize coupling of switching waveforms into other traces and circuits.
- Refer to the [TPS62090EVM-063 Evaluation Module](#) (SLVU670) for an example of component placement, routing, and thermal design.

10.2 Layout Example

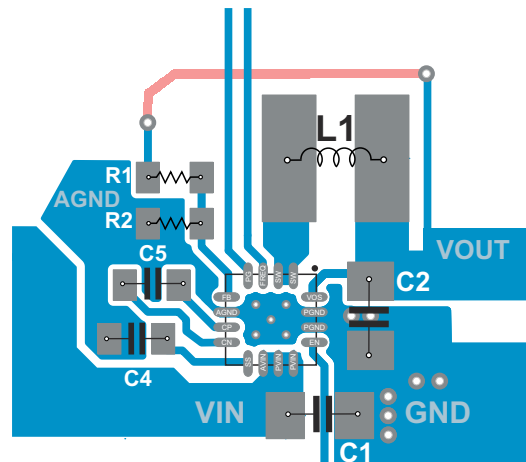

Figure 10-1. TPS62090Q Layout

11 Device and Documentation Support

11.1 Device Support

11.1.1 Third-Party Products Disclaimer

TI'S PUBLICATION OF INFORMATION REGARDING THIRD-PARTY PRODUCTS OR SERVICES DOES NOT CONSTITUTE AN ENDORSEMENT REGARDING THE SUITABILITY OF SUCH PRODUCTS OR SERVICES OR A WARRANTY, REPRESENTATION OR ENDORSEMENT OF SUCH PRODUCTS OR SERVICES, EITHER ALONE OR IN COMBINATION WITH ANY TI PRODUCT OR SERVICE.

11.2 Documentation Support

11.2.1 Related Documentation

For related documentation see the following:

- [Basic Calculation of a Buck Converter's Power Stage](#) (SLVA477)
- [Choosing an Appropriate Pull-up/Pull-down Resistor for Open Drain Outputs](#) (SLVA485)
- [How to Measure the Control Loop of DCS-Control™ Devices](#) (SLVA465)
- [Optimizing the TPS62090 Output Filter](#) (SLVA519)
- [Performing Accurate PFM Mode Efficiency Measurements](#) (SLVA236)
- [QFN/SON PCB Attachment](#) (SLUA271)
- [TPS62090EVM-063 Evaluation Module](#) (SLVU670)
- [Understanding the Absolute Maximum Ratings of the SW Node](#) (SLVA494)

11.3 Receiving Notification of Documentation Updates

To receive notification of documentation updates, navigate to the device product folder on [ti.com](#). Click on *Subscribe to updates* to register and receive a weekly digest of any product information that has changed. For change details, review the revision history included in any revised document.

11.4 Support Resources

[TI E2E™ support forums](#) are an engineer's go-to source for fast, verified answers and design help — straight from the experts. Search existing answers or ask your own question to get the quick design help you need.

Linked content is provided "AS IS" by the respective contributors. They do not constitute TI specifications and do not necessarily reflect TI's views; see TI's [Terms of Use](#).

11.5 Trademarks

DCS-Control™ and TI E2E™ are trademarks of Texas Instruments.
All trademarks are the property of their respective owners.

11.6 Electrostatic Discharge Caution



This integrated circuit can be damaged by ESD. Texas Instruments recommends that all integrated circuits be handled with appropriate precautions. Failure to observe proper handling and installation procedures can cause damage.

ESD damage can range from subtle performance degradation to complete device failure. Precision integrated circuits may be more susceptible to damage because very small parametric changes could cause the device not to meet its published specifications.

11.7 Glossary

[TI Glossary](#) This glossary lists and explains terms, acronyms, and definitions.

12 Mechanical, Packaging, and Orderable Information

The following pages include mechanical, packaging, and orderable information. This information is the most current data available for the designated devices. This data is subject to change without notice and revision of this document. For browser-based versions of this data sheet, refer to the left-hand navigation.

PACKAGING INFORMATION

Orderable Device	Status (1)	Package Type	Package Drawing	Pins	Package Qty	Eco Plan (2)	Lead finish/ Ball material (6)	MSL Peak Temp (3)	Op Temp (°C)	Device Marking (4/5)	Samples
TPS62090QRGTRQ1	ACTIVE	VQFN	RGT	16	3000	RoHS & Green	NIPDAU	Level-2-260C-1 YEAR	-40 to 125	SJG	Samples

(1) The marketing status values are defined as follows:

ACTIVE: Product device recommended for new designs.

LIFEBUY: TI has announced that the device will be discontinued, and a lifetime-buy period is in effect.

NRND: Not recommended for new designs. Device is in production to support existing customers, but TI does not recommend using this part in a new design.

PREVIEW: Device has been announced but is not in production. Samples may or may not be available.

OBSOLETE: TI has discontinued the production of the device.

(2) **RoHS:** TI defines "RoHS" to mean semiconductor products that are compliant with the current EU RoHS requirements for all 10 RoHS substances, including the requirement that RoHS substance do not exceed 0.1% by weight in homogeneous materials. Where designed to be soldered at high temperatures, "RoHS" products are suitable for use in specified lead-free processes. TI may reference these types of products as "Pb-Free".

RoHS Exempt: TI defines "RoHS Exempt" to mean products that contain lead but are compliant with EU RoHS pursuant to a specific EU RoHS exemption.

Green: TI defines "Green" to mean the content of Chlorine (Cl) and Bromine (Br) based flame retardants meet JS709B low halogen requirements of <=1000ppm threshold. Antimony trioxide based flame retardants must also meet the <=1000ppm threshold requirement.

(3) MSL, Peak Temp. - The Moisture Sensitivity Level rating according to the JEDEC industry standard classifications, and peak solder temperature.

(4) There may be additional marking, which relates to the logo, the lot trace code information, or the environmental category on the device.

(5) Multiple Device Markings will be inside parentheses. Only one Device Marking contained in parentheses and separated by a "-" will appear on a device. If a line is indented then it is a continuation of the previous line and the two combined represent the entire Device Marking for that device.

(6) Lead finish/Ball material - Orderable Devices may have multiple material finish options. Finish options are separated by a vertical ruled line. Lead finish/Ball material values may wrap to two lines if the finish value exceeds the maximum column width.

Important Information and Disclaimer: The information provided on this page represents TI's knowledge and belief as of the date that it is provided. TI bases its knowledge and belief on information provided by third parties, and makes no representation or warranty as to the accuracy of such information. Efforts are underway to better integrate information from third parties. TI has taken and continues to take reasonable steps to provide representative and accurate information but may not have conducted destructive testing or chemical analysis on incoming materials and chemicals. TI and TI suppliers consider certain information to be proprietary, and thus CAS numbers and other limited information may not be available for release.

In no event shall TI's liability arising out of such information exceed the total purchase price of the TI part(s) at issue in this document sold by TI to Customer on an annual basis.

OTHER QUALIFIED VERSIONS OF TPS62090-Q1 :

- Catalog : [TPS62090](#)

NOTE: Qualified Version Definitions:

- Catalog - TI's standard catalog product

TAPE AND REEL INFORMATION

QUADRANT ASSIGNMENTS FOR PIN 1 ORIENTATION IN TAPE

*All dimensions are nominal

Device	Package Type	Package Drawing	Pins	SPQ	Reel Diameter (mm)	Reel Width W1 (mm)	A0 (mm)	B0 (mm)	K0 (mm)	P1 (mm)	W (mm)	Pin1 Quadrant
TPS62090QRGTRQ1	VQFN	RGT	16	3000	330.0	12.4	3.3	3.3	1.1	8.0	12.0	Q2

TAPE AND REEL BOX DIMENSIONS

*All dimensions are nominal

Device	Package Type	Package Drawing	Pins	SPQ	Length (mm)	Width (mm)	Height (mm)
TPS62090QRGTRQ1	VQFN	RGT	16	3000	346.0	346.0	33.0

RGT 16

GENERIC PACKAGE VIEW

VQFN - 1 mm max height

PLASTIC QUAD FLATPACK - NO LEAD



Images above are just a representation of the package family, actual package may vary.
Refer to the product data sheet for package details.

4203495/1



SIDE WALL METAL THICKNESS DIM A	
OPTION 1	OPTION 2
0.1	0.2

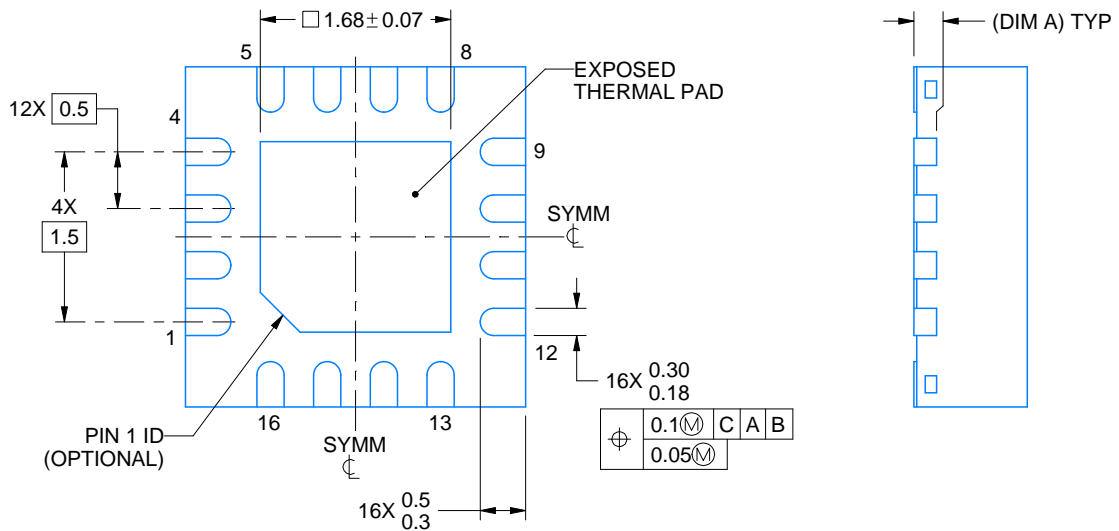

4222419/D 04/2022

NOTES:

1. All linear dimensions are in millimeters. Any dimensions in parenthesis are for reference only. Dimensioning and tolerancing per ASME Y14.5M.
2. This drawing is subject to change without notice.
3. The package thermal pad must be soldered to the printed circuit board for thermal and mechanical performance.

EXAMPLE BOARD LAYOUT

RGT0016C

VQFN - 1 mm max height

PLASTIC QUAD FLATPACK - NO LEAD

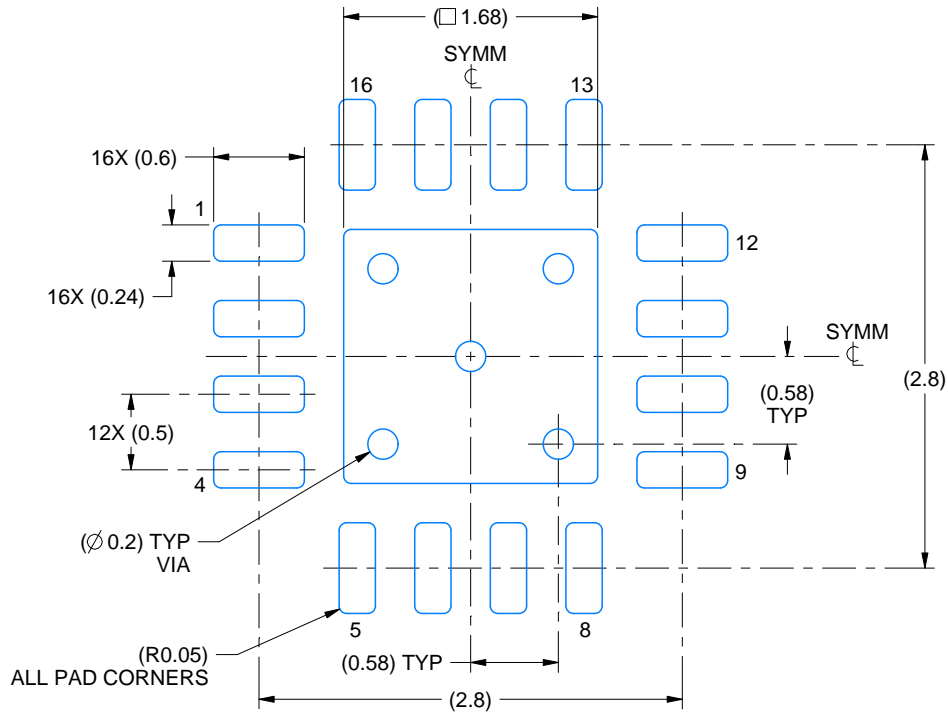

LAND PATTERN EXAMPLE
EXPOSED METAL SHOWN
SCALE:20X

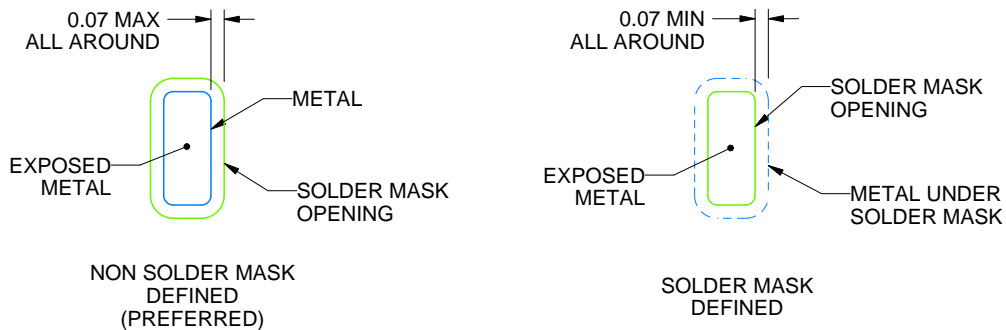

SOLDER MASK DETAILS

4222419/D 04/2022

NOTES: (continued)

4. This package is designed to be soldered to a thermal pad on the board. For more information, see Texas Instruments literature number SLUA271 (www.ti.com/lit/slua271).
5. Vias are optional depending on application, refer to device data sheet. If any vias are implemented, refer to their locations shown on this view. It is recommended that vias under paste be filled, plugged or tented.

EXAMPLE STENCIL DESIGN

RGT0016C

VQFN - 1 mm max height

PLASTIC QUAD FLATPACK - NO LEAD



SOLDER PASTE EXAMPLE
BASED ON 0.125 mm THICK STENCIL

EXPOSED PAD 17:
85% PRINTED SOLDER COVERAGE BY AREA UNDER PACKAGE
SCALE:25X

4222419/D 04/2022

NOTES: (continued)

6. Laser cutting apertures with trapezoidal walls and rounded corners may offer better paste release. IPC-7525 may have alternate design recommendations.

IMPORTANT NOTICE AND DISCLAIMER

TI PROVIDES TECHNICAL AND RELIABILITY DATA (INCLUDING DATA SHEETS), DESIGN RESOURCES (INCLUDING REFERENCE DESIGNS), APPLICATION OR OTHER DESIGN ADVICE, WEB TOOLS, SAFETY INFORMATION, AND OTHER RESOURCES "AS IS" AND WITH ALL FAULTS, AND DISCLAIMS ALL WARRANTIES, EXPRESS AND IMPLIED, INCLUDING WITHOUT LIMITATION ANY IMPLIED WARRANTIES OF MERCHANTABILITY, FITNESS FOR A PARTICULAR PURPOSE OR NON-INFRINGEMENT OF THIRD PARTY INTELLECTUAL PROPERTY RIGHTS.

These resources are intended for skilled developers designing with TI products. You are solely responsible for (1) selecting the appropriate TI products for your application, (2) designing, validating and testing your application, and (3) ensuring your application meets applicable standards, and any other safety, security, regulatory or other requirements.

These resources are subject to change without notice. TI grants you permission to use these resources only for development of an application that uses the TI products described in the resource. Other reproduction and display of these resources is prohibited. No license is granted to any other TI intellectual property right or to any third party intellectual property right. TI disclaims responsibility for, and you will fully indemnify TI and its representatives against, any claims, damages, costs, losses, and liabilities arising out of your use of these resources.

TI's products are provided subject to [TI's Terms of Sale](#) or other applicable terms available either on [ti.com](https://www.ti.com) or provided in conjunction with such TI products. TI's provision of these resources does not expand or otherwise alter TI's applicable warranties or warranty disclaimers for TI products.

TI objects to and rejects any additional or different terms you may have proposed.

Mailing Address: Texas Instruments, Post Office Box 655303, Dallas, Texas 75265
Copyright © 2023, Texas Instruments Incorporated