

# TPS92205x 65-V 2-A / 4-A Buck LED Driver with Inductive Fast Dimming

## 1 Features

- 4.5-V to 65-V wide input range
- LED common anode connection
- Integrated 150-mΩ MOSFET with typical 3-A / 6-A current limit
- Optional switching frequency: 100 kHz to 2.2 MHz
- Spread spectrum for TPS922053 and TPS922055
- Advanced dimming options:
  - Analog dimming (256:1)
  - Fast PWM dimming (150-ns pulse width)
  - Hybrid and flexible dimming (2,000:1 at 20-kHz PWM, 10,000:1 at 4-kHz PWM, 1,000,000:1 at 120-Hz PWM)
- CC / CV charging mode
- Full protection features:
  - LED open and short protection
  - Switching FET open and short protection
  - External component failure protection
  - Cycle-by-cycle current limit
  - Thermal shutdown
  - Fault output (open drain)
- Configurable thermal foldback curve
- VSON, WSON and SOT23 package options

## 2 Applications

- Constant illumination:
  - Indoor, outdoor, professional lighting
  - Medical, surgical lighting
  - Projector, laser TV, printer, IP camera
- Instant illumination:
  - Machine vision, camera flash
  - Fire alarm, strobe
- CC and CV source:
  - LCD backlighting
  - Battery charging
  - TEC control

## 3 Description

The TPS92205x family is a 2-A / 4-A non-synchronous Buck LED driver with 4.5-V to 65-V wide input range. By integrating the low-side NMOS switch, the device is capable of driving LEDs as well as charging batteries with high power density and high efficiency. The family also supports common anode connection and single layer PCB design. The switching frequency is configurable from 100 kHz to 2.2 MHz with optional spread spectrum feature for better EMI performance.

The TPS92205x family supports four dimming options, including analog, PWM, hybrid and flexible dimming. Each dimming method can be configured through the PWM and ADIM input pins by means of simple high and low signals. The family adopts an adaptive off-time current mode control along with smart and accurate sampling to enable inductive fast dimming (IFD) and achieve high dimming accuracy.

The TPS92205x family also provides multiple systematic protections, including LED open and short, sense resistor open and short, configurable thermal foldback and thermal shutdown. A Fault output sends out acknowledge signals as soon as any fault condition is detected.

### Device Information

PART NUMBER	PACKAGE	BODY SIZE (NOM)
TPS92205x	VSON (14)	4.5 mm x 3.0 mm
	WSON (12)	3.0 mm x 3.0 mm
TPS922052, TPS922053	SOT-23-THN (14)	4.2 mm x 3.3 mm

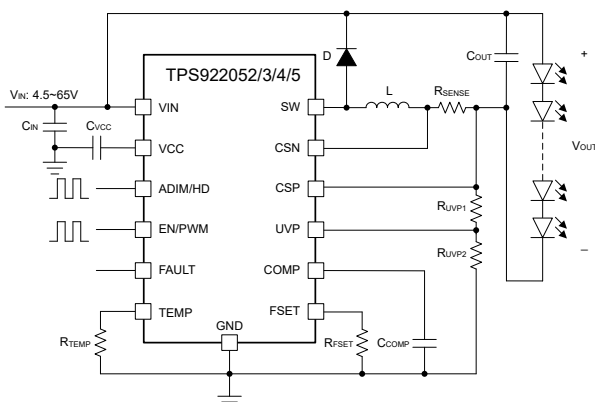

**Simplified Schematic**

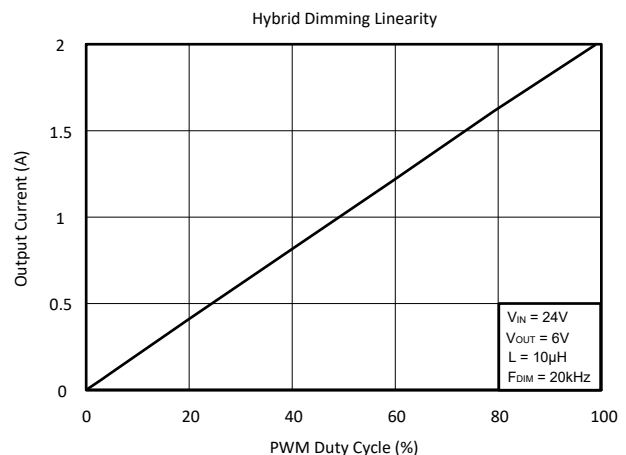

**LED Brightness Linearity**



## Table of Contents

<b>1 Features</b> .....	1	8.2 Functional Block Diagram.....	11
<b>2 Applications</b> .....	1	8.3 Feature Description.....	12
<b>3 Description</b> .....	1	<b>9 Application and Implementation</b> .....	21
<b>4 Revision History</b> .....	2	9.1 Application Information.....	21
<b>5 Device Comparison Table</b> .....	3	9.2 Typical Application.....	21
<b>6 Pin Configuration and Functions</b> .....	4	9.3 Power Supply Recommendations.....	31
<b>7 Specifications</b> .....	6	9.4 Layout.....	31
7.1 Absolute Maximum Ratings.....	6	<b>10 Device and Documentation Support</b> .....	33
7.2 ESD Ratings.....	6	10.1 Receiving Notification of Documentation Updates..	33
7.3 Recommended Operating Conditions.....	6	10.2 Support Resources.....	33
7.4 Thermal Information.....	6	10.3 Trademarks.....	33
7.5 Electrical Characteristics.....	7	10.4 Electrostatic Discharge Caution.....	33
7.6 Typical Characteristics.....	9	10.5 Glossary.....	33
<b>8 Detailed Description</b> .....	11	<b>11 Mechanical, Packaging, and Orderable Information</b> .....	33
8.1 Overview.....	11		

## 4 Revision History

Changes from Revision * (June 2023) to Revision A (September 2023)	Page
• Updated document from Advance Information to Production Data.....	1

## 5 Device Comparison Table

Part Number	Package	Typical Current Limit	Spread Spectrum	Operation Junction Temperature
TPS922052DMTR	VSON (14)	3 A	Disabled	-40 °C to 125 °C
TPS922052DRRR	WSON (12)	3 A	Disabled	-40 °C to 125 °C
TPS922052DYR	SOT-23-THN (14)	3 A	Disabled	-40 °C to 125 °C
TPS922053DMTR	VSON (14)	3 A	Enabled	-40 °C to 125 °C
TPS922053DRRR	WSON (12)	3 A	Enabled	-40 °C to 125 °C
TPS922053DYR	SOT-23-THN (14)	3 A	Enabled	-40 °C to 125 °C
TPS922054DMTR	VSON (14)	6 A	Disabled	-40 °C to 125 °C
TPS922054DRRR	WSON (12)	6 A	Disabled	-40 °C to 125 °C
TPS922054MDMTR	VSON (14)	6 A	Disabled	-55 °C to 125 °C
TPS922055DMTR	VSON (14)	6 A	Enabled	-40 °C to 125 °C
TPS922055DRRR	WSON (12)	6 A	Enabled	-40 °C to 125 °C
TPS922055MDMTR	VSON (14)	6 A	Enabled	-55 °C to 125 °C

## 6 Pin Configuration and Functions

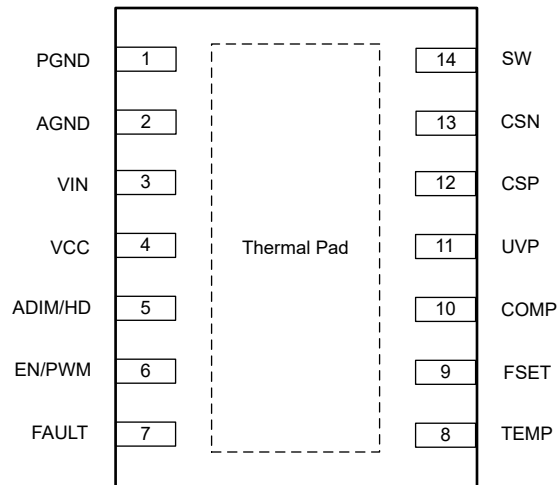

**Figure 6-1. 14-Pin VSON Top View**

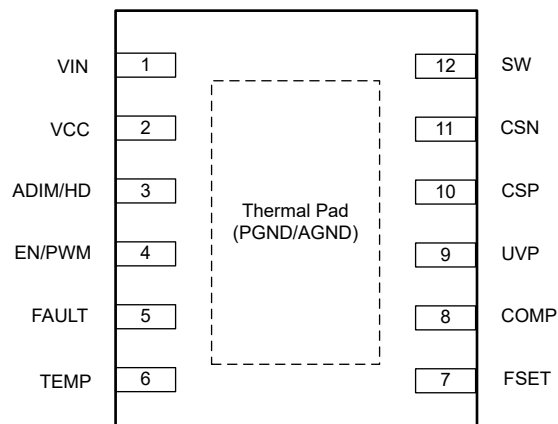

**Figure 6-2. 12-Pin WSON Top View**

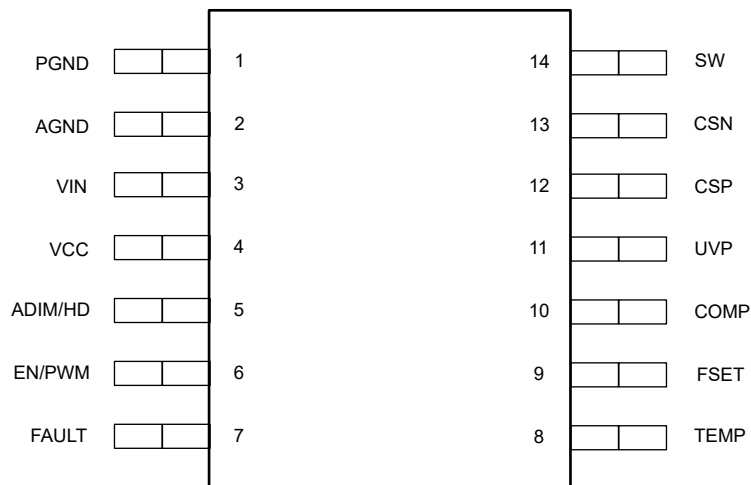

**Figure 6-3. 14-Pin SOT-23-THIN Top View**

**Table 6-1. Pin Functions**

NAME	PIN			TYPE <sup>(1)</sup>	DESCRIPTION
	SOT23-14	VSON-14	WSON-12		
PGND	1	1	Thermal Pad	G	Power ground pin.
AGND	2	2	Thermal Pad	G	Analog ground pin.
VIN	3	3	1	P	Input power pin.
VCC	4	4	2	P	Internal LDO output pin. Connect with a 10-V, 1- $\mu$ F capacitor to AGND.
ADIM/HD	5	5	3	I	Analog dimming or hybrid dimming pin. Pull high for PWM dimming only, pull low for hybrid dimming, input PWM signal for analog dimming.
EN/PWM	6	6	4	I	Enable pin or PWM dimming pin. Pull high for always on, pull low for disabling the device, input PWM signal for PWM dimming.
FAULT	7	7	5	O	Open drain output pin. Pull low when fault is detected.
TEMP	8	8	6	I/O	Thermal foldback pin. Put different resistor values to AGND to set different thermal foldback behavior curves.
FSET	9	9	7	I/O	Switching frequency set pin, with range of 100 kHz to 2.2 MHz. Put different resistor values to AGND for different switching frequencies.
COMP	10	10	8	I/O	Error-amplifier output pin. Connect capacitors to AGND. Different capacitor values determine different softstart times and bandwidths.
UVP	11	11	9	I	Undervoltage detection pin. Put different resistor dividers to set the LED open detection thresholds.
CSP	12	12	10	I	LED current sense positive pin.
CSN	13	13	11	I	LED current sense negative pin.
SW	14	14	12	P	Switching node pin. Internally connected to the low-side MOSFET. Connect with the power inductor and the schottky diode.
Thermal Pad	N/A	Y	Y	G	Power/analog ground pin for WSON-12 package.

(1) I = Input, O = Output, P = Supply, G = Ground

## 7 Specifications

### 7.1 Absolute Maximum Ratings

over operating ambient temperature range (unless otherwise noted)<sup>(1)</sup>

		MIN	MAX	UNIT
Voltage on pins	VIN, UVP, CSP, CSN, SW	-0.3	65	V
Voltage on pins	VCC, ADIM/HD, EN/PWM, FAULT, TEMP, FSET, COMP	-0.3	5.5	V
Operation junction temperature	T <sub>J</sub>	-40	125	°C
Operation junction temperature (TPS922054MDMTR, TPS922055M DMTR)	T <sub>J</sub>	-55	125	°C
Storage temperature	T <sub>stg</sub>	-65	150	°C

- (1) Stresses beyond those listed under *Absolute Maximum Ratings* may cause permanent damage to the device. These are stress ratings only, which do not imply functional operation of the device at these or any other conditions beyond those indicated under *Recommended Operating Conditions*. Exposure to absolute-maximum-rated conditions for extended periods may affect device reliability.

### 7.2 ESD Ratings

			VALUE	UNIT
V <sub>(ESD)</sub>	Electrostatic discharge	Human-body model (HBM), per ANSI/ESDA/JEDEC JS-001 <sup>(1)</sup>	±2000	V
		Charged-device model (CDM), per JEDEC specification JESD22-C101 <sup>(2)</sup>	±500	

- (1) JEDEC document JEP155 states that 500-V HBM allows safe manufacturing with a standard ESD control process.  
 (2) JEDEC document JEP157 states that 250-V CDM allows safe manufacturing with a standard ESD control process.

### 7.3 Recommended Operating Conditions

over operating ambient temperature range (unless otherwise noted)

		MIN	MAX	UNIT
Input voltage range	VIN	4.5	63	V
Input voltage range	UVP, CSP, CSN	0	63	V
Input voltage range	VCC, ADIM/HD, EN/PWM, TEMP, FSET	0	5	V
Output voltage range	SW	0	63	V
	FAULT, COMP	0	5	V
Operation junction temperature	T <sub>J</sub>	-40	125	°C
Operation junction temperature (TPS922054MDMTR, TPS9220 55MDMTR)	T <sub>J</sub>	-55	125	°C

### 7.4 Thermal Information

THERMAL METRIC <sup>(1)</sup>		TPS92205x	TPS92205x	TPS92205x	UNIT
		SOT	WSON	VSON	
		14 PINS	12 PINS	14 PINS	
R <sub>θJA</sub>	Junction-to-ambient thermal resistance	96.0	47.4	39.1	°C/W
R <sub>θJC(top)</sub>	Junction-to-case (top) thermal resistance	33.5	44.2	39.5	°C/W
R <sub>θJB</sub>	Junction-to-board thermal resistance	33.1	19.7	14.7	°C/W
ψ <sub>JT</sub>	Junction-to-top characterization parameter	0.7	1.0	0.9	°C/W
ψ <sub>JB</sub>	Junction-to-board characterization parameter	32.9	19.7	14.7	°C/W

- (1) For more information about traditional and new thermal metrics, see the *Semiconductor and IC Package Thermal Metrics* application report, [SPRA953](#).

## 7.5 Electrical Characteristics

The electrical ratings specified in this section apply to all specifications in this document, unless otherwise noted. These specifications are interpreted as conditions that do not degrade the device parametric or functional specifications for the life of the product containing it.  $T_J = -40^{\circ}\text{C}$  to  $+125^{\circ}\text{C}$ ,  $V_{IN} = 4.5\text{ V}$  to  $60\text{ V}$ , (unless otherwise noted).

PARAMETER		TEST CONDITIONS	MIN	TYP	MAX	UNIT
<b>INPUT SUPPLY</b>						
$V_{VIN\_UVLO}$	$V_{IN}$ undervoltage lockout	Rising $V_{IN}$	3.0	3.2	3.4	V
		Falling $V_{IN}$	2.8	3.0	3.2	V
	Hysteresis			0.2		V
$I_{SD}$	Shut down current from $V_{IN}$	$V_{IN} = 12\text{ V}$ , $V_{EN/PWM} = 0\text{ V}$ , device disabled		0.8	2.3	$\mu\text{A}$
$I_{OFF}$	PWM off quiescent current from $V_{IN}$	$V_{IN} = 12\text{ V}$ , $V_{EN/PWM} = 0\text{ V}$ , device enabled		2.5		mA
$I_{OP}$	Normal operating current	400-kHz switching frequency		4.6		mA
$I_{OP}$	Normal operating current	2.2-MHz switching frequency		10.0		mA
$V_{VCC}$	Internal LDO output voltage	$I_{VCC} = 10\text{ mA}$	5.0	5.15	5.3	V
$I_{VCC\_LIM}$	Internal LDO output current limit		38	47	56	mA
<b>DIMMING</b>						
$V_{PWM\_L}$	Low-level input voltage				0.4	V
$V_{PWM\_H}$	High-level input voltage		1.2			V
$V_{ADIM\_L}$	Low-level input voltage				0.4	V
$V_{ADIM\_H}$	High-level input voltage		1.2			V
$t_{PWM\_OUT\_ON}$	PWM output minimum on time				150	ns
$t_{PWM\_IN\_ON}$	PWM input minimum on time				150	ns
$t_{PWM\_IN\_OFF}$	PWM input minimum off time to disable device		57		77	ms
$f_{ADIM}$	Analog Dimming input frequency	6-bit ADIM resolution	0.1		156	kHz
$f_{ADIM}$	Analog Dimming input frequency	8-bit ADIM resolution	0.1		39	kHz
<b>FAULT</b>						
$V_{OL}$	Output level low	$I = 3\text{ mA}$			0.1	V
$I_{LEAKAGE}$	Output leakage current	$V = 5\text{ V}$			1	$\mu\text{A}$
<b>FEEDBACK AND ERROR AMPLIFIER</b>						
$g_{M(ea)}$	Transconductance gain	ADIM 100% duty cycle, $V_{CSP-CSN} = 200\text{ mV}$ , $V_{COMP} = 1.5\text{ V}$	205	265	325	$\mu\text{A/V}$
$I_{COMP}$	Source/sink current	ADIM 100% duty cycle, $V_{CSP-CSN} = 200\text{ mV} \pm 200\text{ mV}$ , $V_{COMP} = 1.5\text{ V}$	$\pm 24$	$\pm 40$	$\pm 56$	$\mu\text{A}$
$V_{CSP-CSN}$	Current sense threshold	ADIM 100% duty cycle	194	200	206	mV
$V_{CSP-CSN}$	Current sense threshold	ADIM 12.5% duty cycle, compared with 100% duty cycle	11.875	12.5	13.125	%
$V_{CSP-CSN}$	Current sense threshold	ADIM 1.17% duty cycle, compared with 100% duty cycle	0.82	1.17	1.52	%
$I_{LEAK\_CSP/N}$	CSP+CSN pin leakage current	$V_{IN} = 60\text{ V}$ , $V_{EN/PWM} = 5\text{ V}$	22		31	$\mu\text{A}$
$I_{LEAK\_CSP/N}$	CSP+CSN pin leakage current	$V_{IN} = 60\text{ V}$ , $V_{EN/PWM} = 0\text{ V}$	10		15	$\mu\text{A}$
<b>POWER STAGE</b>						
$R_{DSON}$	Switching FET on resistance	$V_{IN} \geq 5\text{ V}$		150		m $\Omega$
$t_{min\_ON}$	Switching FET minimum on time			100		ns
$t_{min\_OFF}$	Switching FET minimum off time			100		ns
$f_{SW}$	Switching FET frequency		0.1		2.2	MHz
<b>CURRENT LIMIT</b>						
$I_{LIM}$	Switching FET cycle-by-cycle current limit (TPS922052, TPS922053)		2.6	3	3.6	A
$I_{LIM}$	Switching FET cycle-by-cycle current limit (TPS922054, TPS922055)		5.2	6	7	A
<b>THERMAL PROTECTION</b>						
$T_{th}$	Thermal foldback starting temperature threshold	$R_{TEMP} = 20\text{ k}\Omega$		130		$^{\circ}\text{C}$

The electrical ratings specified in this section apply to all specifications in this document, unless otherwise noted. These specifications are interpreted as conditions that do not degrade the device parametric or functional specifications for the life of the product containing it.  $T_J = -40^{\circ}\text{C}$  to  $+125^{\circ}\text{C}$ ,  $V_{IN} = 4.5\text{ V}$  to  $60\text{ V}$ , (unless otherwise noted).

PARAMETER		TEST CONDITIONS	MIN	TYP	MAX	UNIT
T <sub>TSD</sub>	Thermal shutdown temperature			165		°C
	Hysteresis			15		°C



## 7.6 Typical Characteristics

$V_{IN} = 24\text{ V}$ ,  $I_{OUT} = 3\text{ A}$ , LED count = 2,  $L = 10\ \mu\text{H}$ ,  $F_{SW} = 400\text{ kHz}$ , unless otherwise specified

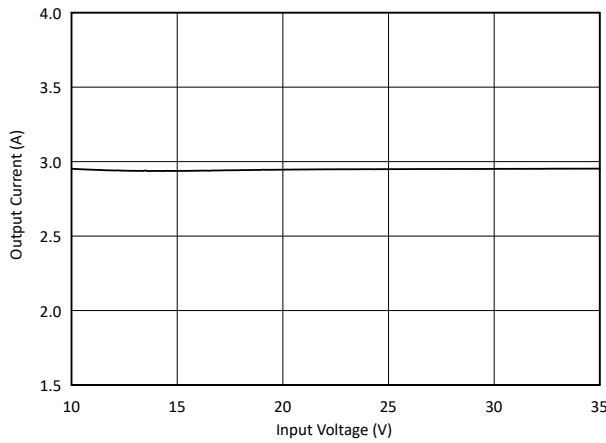

**Figure 7-1. Output Current vs. Input Voltage**

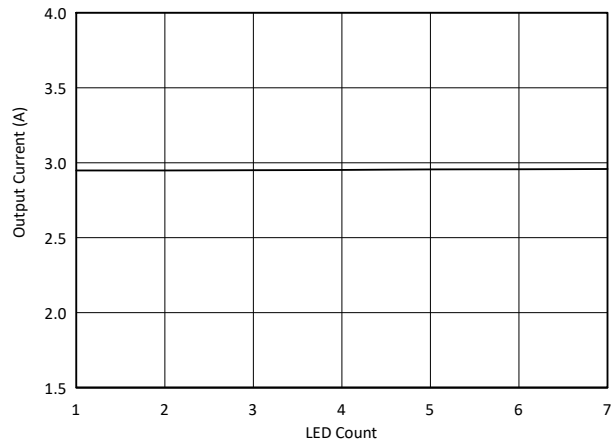

**Figure 7-2. Output Current vs. LED Count**

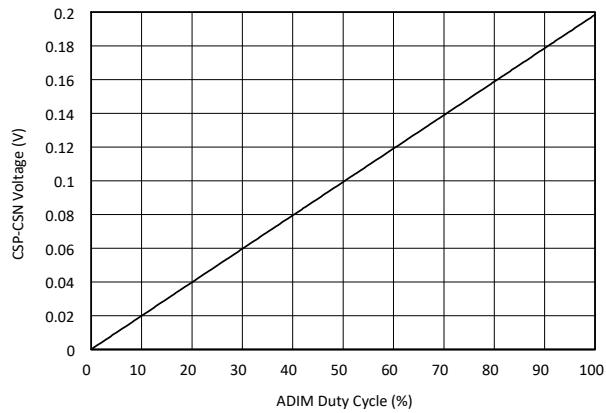

**Figure 7-3. ADIM Duty Cycle vs. CSP-CSN Voltage in Analog Dimming**

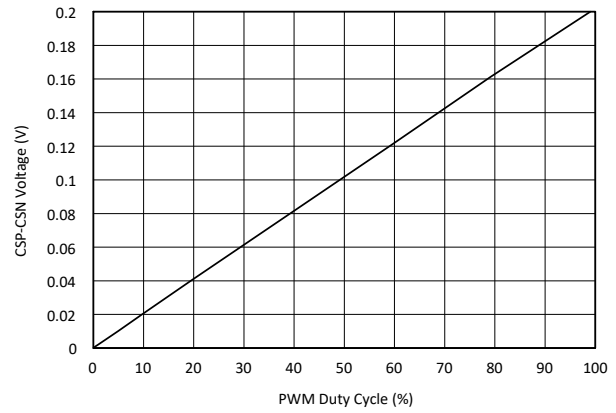

**Figure 7-4. PWM Duty Cycle vs. CSP-CSN Voltage in 20-kHz Hybrid Dimming**

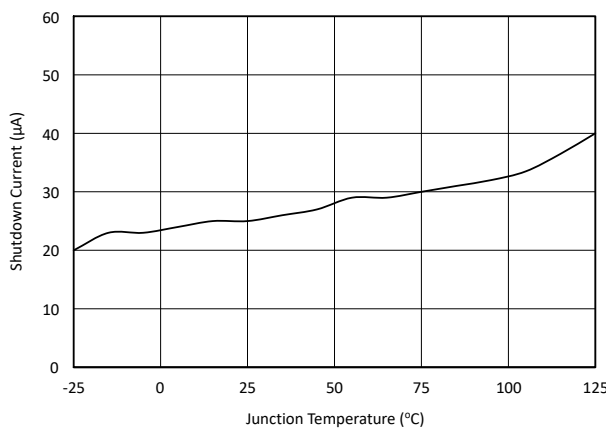

**Figure 7-5. Shutdown Current vs. Junction Temperature**

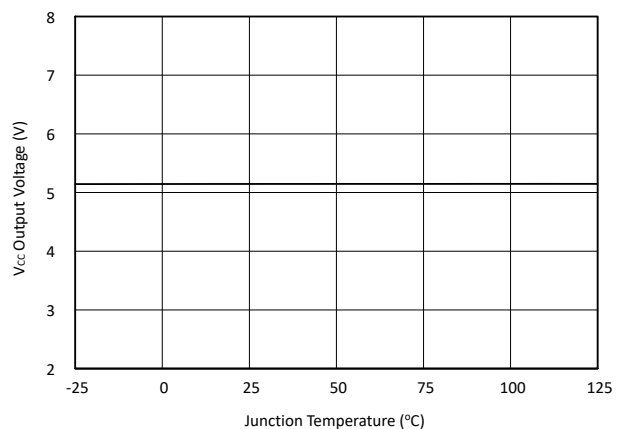

**Figure 7-6. Internal LDO Output vs. Junction Temperature**

## 7.6 Typical Characteristics (continued)

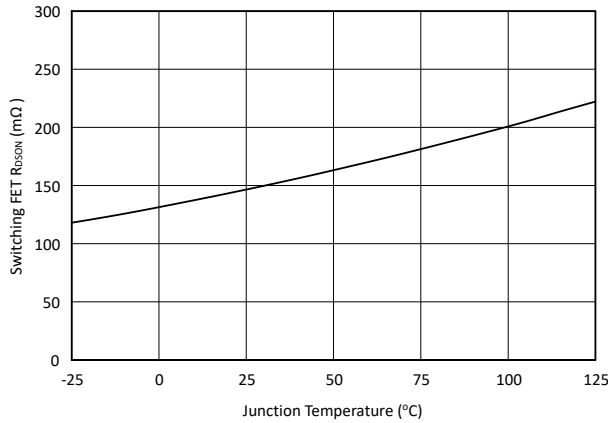

Figure 7-7. Switching FET  $R_{DS(on)}$  vs. Junction Temperature

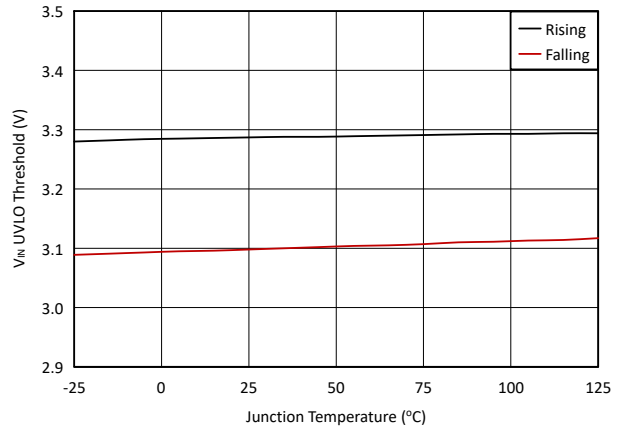

Figure 7-8.  $V_{IN}$  UVLO Threshold vs. Junction Temperature

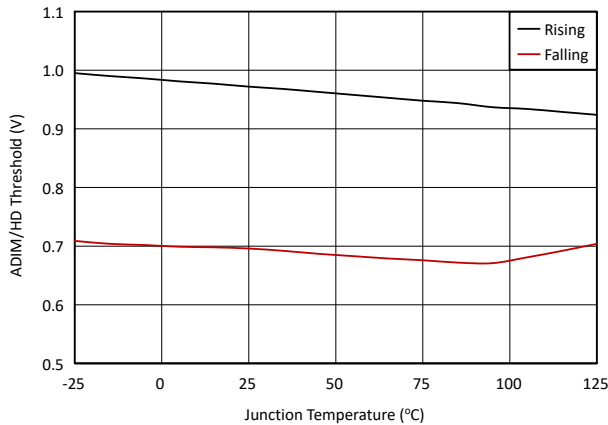

Figure 7-9. ADIM/HD Threshold vs. Junction Temperature

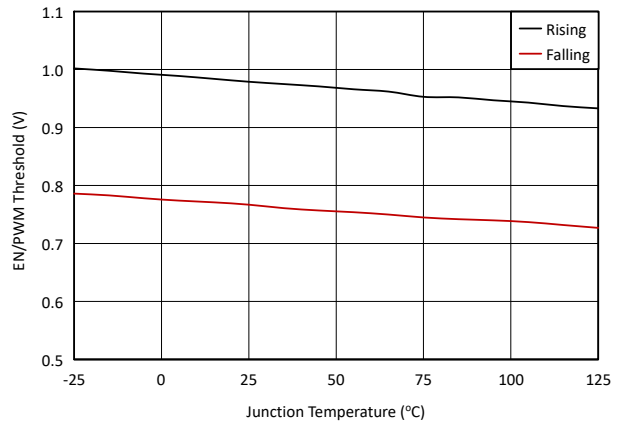

Figure 7-10. EN/PWM Threshold vs. Junction Temperature

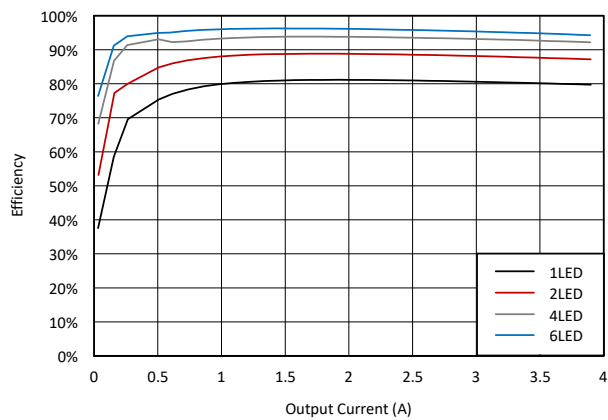

Figure 7-11. Efficiency at 24-V Input Voltage, 4-A Output Current

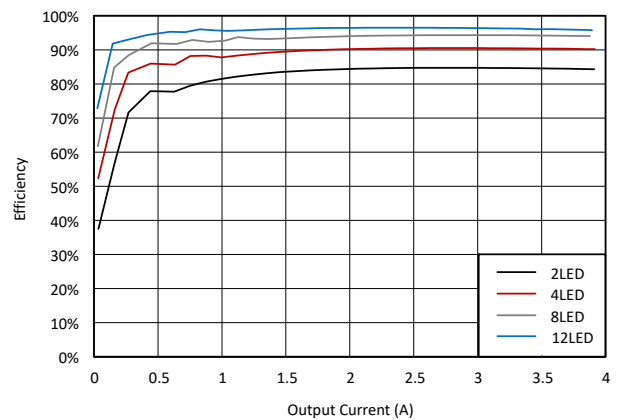

Figure 7-12. Efficiency at 48-V Input Voltage, 4-A Output Current

## 8 Detailed Description

### 8.1 Overview

The TPS92205x family is a 2-A / 4-A non-synchronous Buck LED driver with 4.5-V to 65-V wide input range. By integrating the low-side NMOS switch with constant current and constant voltage controls, the device is capable of not only driving LEDs but also charging batteries with high power density and high efficiency. The device also supports common anode connection and single layer PCB design, hence saving cost of connector, harness and PCB. The switching frequency is configurable through FSET pin, ranging from 100 kHz to 2.2 MHz, with optional spread spectrum feature to decrease the EMC emission and reduce the input filter size.

The device supports four dimming options, including analog dimming, PWM dimming, hybrid dimming and flexible dimming. Each dimming method can be configured through the PWM and ADIM input pins by means of simple high/low sequencing signals at startup. In PWM dimming mode, once the dimming mode is configured, LED is turned on and off corresponding to on and off of the PWM input signal at PWM input pin. The PWM dimming mode supports ultra-narrow pulse width down to 150 ns. In analog dimming mode, LED current is regulated corresponding to the pulse width duty cycle of the PWM input signal at ADIM input pin. In hybrid dimming mode, the LED current is controlled by a pre-determined combination of analog dimming and PWM dimming through the PWM input signal at PWM input pin. In flexible dimming mode, the LED current is controlled by analog dimming through the PWM input signal at ADIM input pins and PWM dimming through the PWM input signal at PWM input pins, respectively. The device adopts an adaptive off-time current mode control along with smart and accurate sampling to enable Inductive Fast Dimming (IFD) and achieve high dimming accuracy. The compensation bandwidth can be adjusted through an external capacitor based on system requirement.

For safety and protection, the devices support full systematic protections including LED open and short, sense resistor open and short, configurable thermal foldback and thermal shutdown protection. The fault output pin sends out acknowledge signals as soon as any fault condition is detected.

### 8.2 Functional Block Diagram

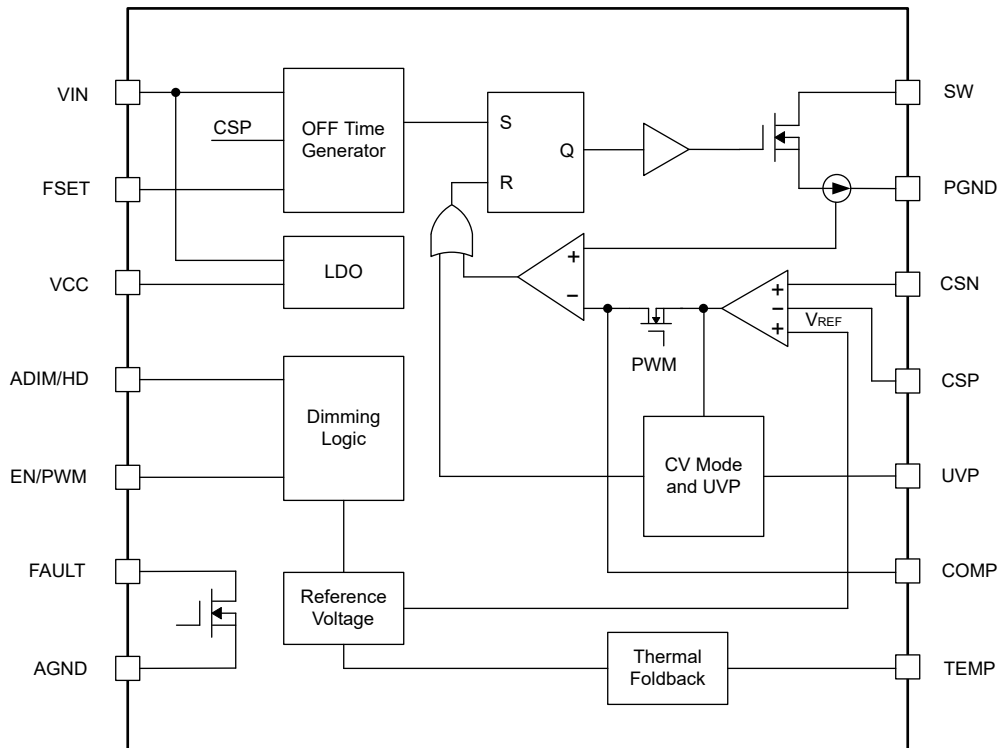

## 8.3 Feature Description

### 8.3.1 Adaptive Off-Time Current Mode Control

The TPS92205x device adopts an adaptive off-time current mode control to support fast transient response over a wide range of operation. The switching frequency is configurable through FSET pin, ranging from 100 kHz to 2.2 MHz.

For average output current regulation, the sensed voltage across the sensing resistor between the CSP and CSN pins is compared with the internal voltage reference,  $V_{REF}$ , through the error amplifier. The output of the error amplifier,  $V_{COMP}$ , passes through an external compensation network and is then compared with the peak current feedback at the PWM comparator. During each switching cycle, when the internal NMOS FET is turned on, the peak current is sensed through the internal FET. When the sensed value of peak current reaches  $V_{COMP}$  at the input of PWM comparator, the NMOS FET is turned off and the adaptive off-time counter starts counting. Once the adaptive off-time counter stops counting, the counter is reset until when the NMOS FET stays off. The counting off time is determined by the external resistor connected to the FSET pin and the input/output feedforward. Thus, the device is able to maintain a nearly constant switching frequency at steady state and regulate the output average current at a desired value.

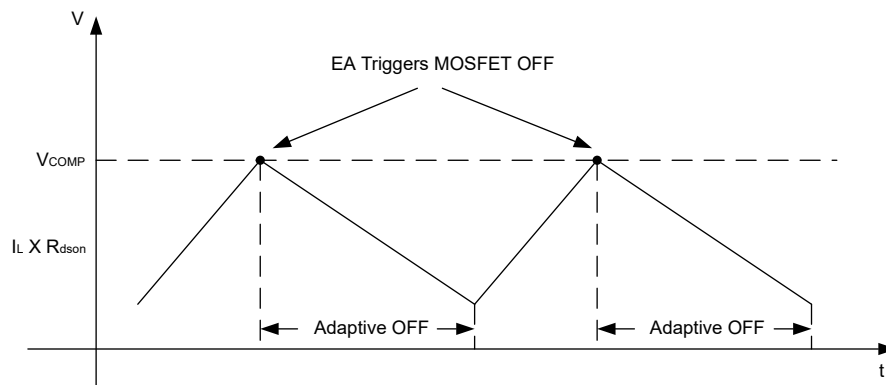

Figure 8-1. Adaptive off-time current mode control method

#### 8.3.1.1 Switching Frequency Settings

The switching frequency of TPS92205x device is adjustable from 100 kHz to 2.2 MHz by means of changing  $R_{FSET}$  connected between FSET pin and AGND. The default switching frequency is 100 kHz when the FSET pin is connected to nothing.

The resistor value and the corresponding switching frequency are listed in the below table:

Table 8-1. Switching Frequency vs.  $R_{FSET}$  Resistor Value

Switching Frequency	Resistor Value (k $\Omega$ )
100 kHz	232
200 kHz	138
300 kHz	83
400 kHz	59
600 kHz	38
800 kHz	28
1 MHz	23
1.2 MHz	18
1.5 MHz	13
1.8 MHz	11
2.2 MHz	9

For example, if  $R_{FSET}$  is set to 59 k $\Omega$ , the corresponding switching frequency is set to 400 kHz.

In most cases, the lower switching frequency, the higher system efficiency and the better thermal behavior.

### 8.3.1.2 Spread Spectrum

The TPS922053 and TPS922055 devices enable the spread spectrum feature ( $\pm 7\%$  from central frequency, 2-kHz modulation frequency) which reduces EMI noise at the switching frequency and its high-order harmonics.

On the other hand, the TPS922052 and TPS922054 devices disable the spread spectrum feature toward better brightness performance in low brightness scenario.

### 8.3.2 Setting LED Current

The LED current is set by the external sensing resistor between CSP and CSN pins. The internal voltage reference,  $V_{REF}$ , is fixed at 200 mV for full-scale LED current,  $I_{LED\_FS}$ , and the sensing resistor can be calculated using [Equation 1](#).

$$R_{SENSE} = \frac{V_{REF}}{I_{LED\_FS}} \quad (1)$$

where

- $V_{REF} = 200 \text{ mV}$

### 8.3.3 Undervoltage Lockout

The TPS92205x family implements an internal undervoltage-lockout (UVLO) circuitry connecting to the VCC pin. The UVLO is triggered and then the device is disabled when the VCC pin voltage falls below the internal UVLO threshold voltage,  $V_{VIN\_UVLO}$  typically 3.0 V, with a typical 0.2-V hysteresis. The VCC pin is the output of an internal regulator of which the input is supplied by the VIN pin. Therefore, if VIN pin voltage falls close to above the  $V_{VIN\_UVLO}$  (around 500 mV above), the UVLO will be triggered.

### 8.3.4 Internal Soft Start

The TPS92205x family implements the internal soft-start function. Once  $V_{IN}$  rises above  $V_{VIN\_MIN}$ , the internal LDO starts to charge  $V_{CC}$  capacitor. It takes approximately 800  $\mu\text{s}$  for  $V_{CC}$  to rise above  $V_{VIN\_UVLO}$  if a 1- $\mu\text{F}$  capacitor is connected to  $V_{CC}$  pin. If EN/PWM pin is pulled high before  $V_{CC}$  rises above  $V_{VIN\_UVLO}$ , the POR is enabled right after  $V_{CC}$  above  $V_{VIN\_UVLO}$  and waits for 100  $\mu\text{s}$  to start dimming mode. EN/PWM pin has to stay high for more than 5  $\mu\text{s}$  after  $V_{CC}$  rises above  $V_{VIN\_UVLO}$ . In this case, if using 1- $\mu\text{F}$   $V_{CC}$  capacitor, it is recommended to wait for 1 ms to start dimming mode after  $V_{IN}$  rises above  $V_{VIN\_MIN}$ .

If EN/PWM pin has the first PWM pulse appearing after  $V_{CC}$  rises above  $V_{VIN\_UVLO}$ , the device waits for 200  $\mu\text{s}$  to enable POR and another 100  $\mu\text{s}$  to start dimming mode. Hence, without triggering  $V_{IN}$  UVLO, the device can be reenabled after disabled and waits for 300  $\mu\text{s}$  to start dimming mode. Note that the initial enable PWM pulse lasting more than 5  $\mu\text{s}$  is required at EN/PWM input pin to enable the device. After dimming mode is started, the device enters four different dimming modes based on the configuration of ADIM/HD pin and EN/PWM pin.

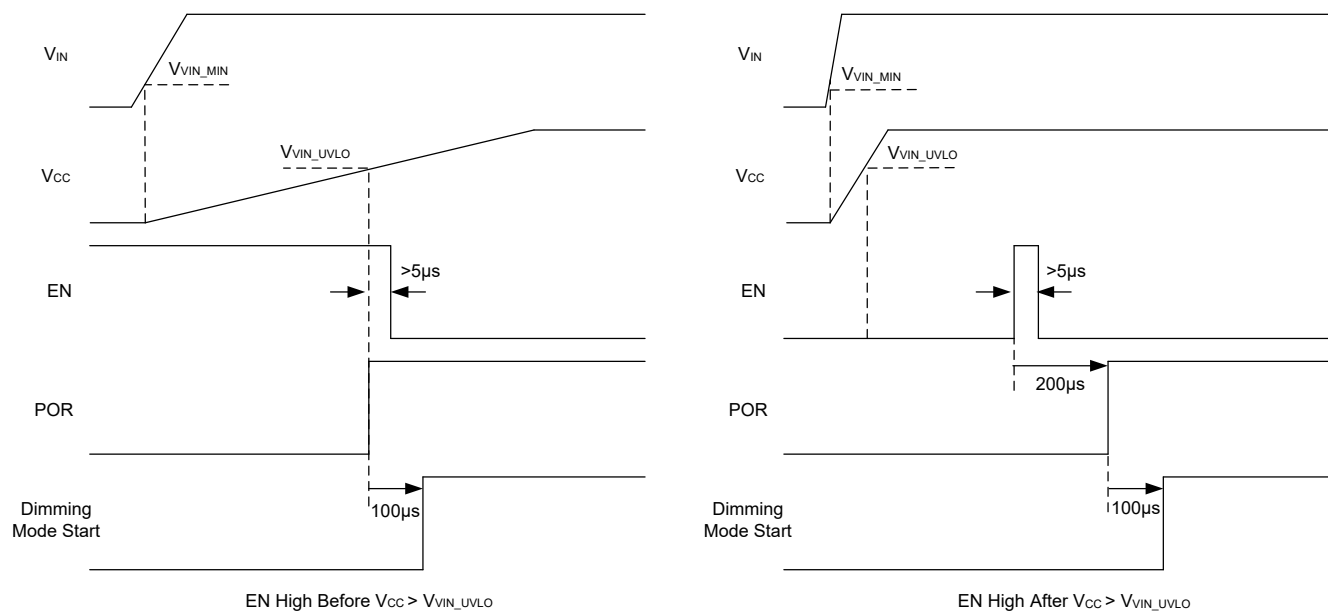
**Figure 8-2. Startup Sequence**

### 8.3.5 Dimming Mode

The TPS92205x family has four optional dimming modes:

- PWM dimming
- Analog dimming
- Hybrid dimming
- Flexible dimming

The dimming mode is started either 1 ms after  $V_{IN}$  exits UVLO or 300  $\mu s$  after renable by EN/PWM pin. The configuration to one of the four dimming modes are shown as below

**Table 8-2. Dimming Mode Configuration**

Dimming Mode	EN/PWM Pin	ADIM/HD Pin
PWM Dimming	PWM signal	High
Analog Dimming	High	PWM signal
Hybrid Dimming	PWM signal	Low
Flexible Dimming	PWM signal	PWM signal

### 8.3.5.1 PWM Dimming

The TPS92205x family supports PWM input signals with ultra-narrow pulse width down to 150 ns for direct PWM dimming. The PWM dimming mode is enabled when the ADIM/HD input pin is always high and the EN/PWM input pin is configured by a PWM input signal.

In PWM dimming mode, when the PWM input signal at the PWM pin turns from low to high, the internal NMOS FET starts switching and the inductor current rises to the determined value. The LED current is then regulated at the determined value as long as the PWM input signal stays high. When the PWM input signal turns from high to low, the internal FET is turned off causing the inductor current falling to zero. The internal FET maintains off and the LED current stays zero as long as the PWM input signal stays low.

### 8.3.5.2 Analog Dimming

The TPS92205x family supports analog dimming which regulates the LED current through the PWM input signal at the ADIM/HD pin. The analog dimming mode is enabled when the EN/PWM pin is always high and the ADIM/HD pin is configured by a PWM input signal.

The internal voltage reference,  $V_{REF}$ , starts to rise after the first PWM pulse appears at the ADIM/HD pin. A 1- $\mu$ s minimum on-time of the first PWM pulse is required for the internal digital circuits to enter the analog dimming mode.  $V_{REF}$  continues to increase until the end of second PWM cycle and then changes to the desired value in proportion to the duty cycle of the PWM pulse. The minimum on-time of the PWM pulse after the first is 100 ns for the digital circuits to detect the duty cycle.

$V_{REF}$  is 200 mV when the PWM input signal at the ADIM/HD pin has a 100% duty cycle, for instance, and  $V_{REF}$  is 20 mV when the PWM input signal has a 10% duty cycle. The initial change takes approximately 5 ms if  $V_{REF}$  is 200 mV. The analog dimming enables 8-bit resolution which corresponds to 0.4% duty cycle step change at the ADIM/HD pin. Also, the circuit is able to respond to the duty cycle change of the PWM input signal with tens of micro-seconds delay.

### 8.3.5.3 Hybrid Dimming

The TPS92205x family supports a unique hybrid dimming function to maximize the dimming performance, especially when both high dimming frequency and high dimming ratio are needed. The hybrid dimming mode is enabled when the ADIM/HD pin is always low and the EN/PWM pin is configured by a PWM input signal.

In the hybrid dimming mode, the LED current is regulated by the analog dimming at high brightness level (12.5% to 100%) and by the PWM dimming at low brightness level (0% to 12.5%), respectively. At high brightness level, the internal voltage reference,  $V_{REF}$ , changes in proportion to the duty cycle of the PWM input signal at the EN/PWM pin with 8-bit resolution. At low brightness level,  $V_{REF}$  stays unchanged and an internal PWM generator is enabled. Thus, the LED is turned on and off corresponding to the on and off of the internal PWM signal of which the frequency and the duty cycle are configured by the PWM input signal at the EN/PWM pin. In addition, the internal PWM signal has a 0.4% hysteresis response when the PWM input duty cycle changes between increasing and decreasing. The detailed hybrid dimming behavior is illustrated in the below figure.

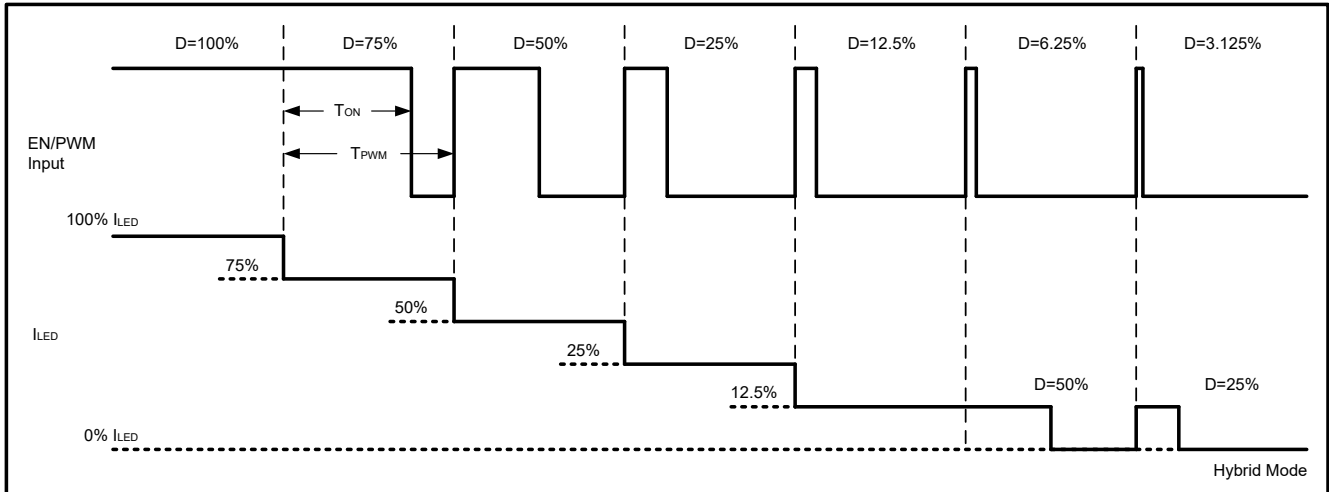
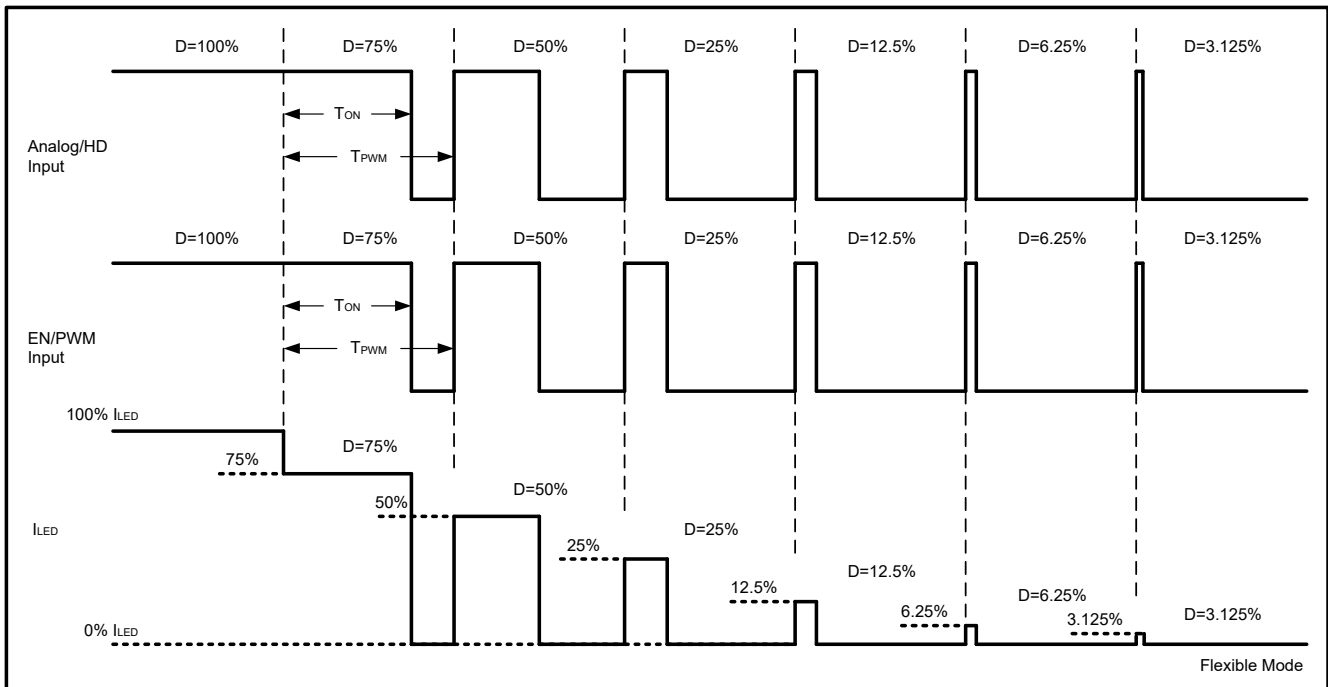

**Figure 8-3. Hybrid Dimming**



### 8.3.5.4 Flexible Dimming

The TPS92205x family also supports flexible dimming to maximize the dimming ratio and the flexibility of dimming control, in which the LED current value and the on/off behavior can be controlled independently. The flexible dimming mode is enabled when both the ADIM/HD pin and the EN/PWM pin are configured by PWM input signals at the same time. Therefore, in flexible dimming mode, the LED is turned on and off corresponding to the on and off of the PWM input signal at the EN/PWM pin while the reference voltage changes in proportion to the duty cycle of the PWM input signal at the ADIM/HD pin. All the initial conditions and resolutions of PWM dimming and analog dimming apply to the flexible dimming.



**Figure 8-4. Flexible Dimming**

### 8.3.6 CC/CV Charging Mode

The TPS92205x family enables constant current (CC) / constant voltage (CV) charging operation by configuring UVP pin. When  $V_{UVP}$  is above the CC threshold  $V_{CC\_TH}$  determined by users, the device performs as a controllable constant current source and generates a relatively low output current controlled by a low-duty-cycle PWM signal at ADIM/HD pin for pre-charge. When  $V_{UVP}$  is below  $V_{CC\_TH}$  but above 1.4 V, the device generates a relatively high output current controlled by a high-duty-cycle PWM signal at ADIM/HD pin for CC operation. CV charging mode is enabled and the output current continuously decreases after  $V_{UVP}$  falls below 1.4 V. The device then returns to CC operation mode once  $V_{UVP}$  rises above 1.4 V.

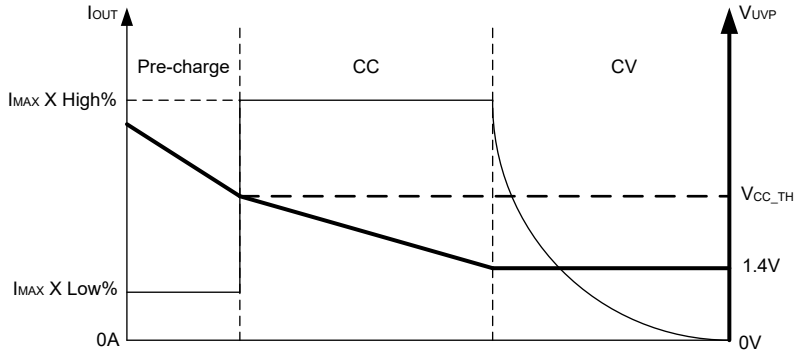

Figure 8-5. CC/CV Mode Transition

### 8.3.7 Fault Protection

The TPS92205x family is able to provide fault protections and send fault report signals in many fault conditions, including LED open, LED  $\pm$  short, LED short to PGND, sense resistor open and short, internal switching FET open and short, and thermal shutdown.

**Table 8-3. Protections**

TYPE	CRITERION	BEHAVIOR
LED open load	$V_{UVP} < 1\text{ V}$	FAULT pin pull low. The device stops switching and recovers when fault is removed.
LED+ and LED- short circuit	$V_{IN} - V_{CSN} < 750\text{ mV}$	FAULT pin pull low. The device keeps normal behavior.
LED- short to PGND	$V_{UVP} < 1\text{ V}$	FAULT pin pull low. The device stops switching and recovers when fault is removed.
Sense-resistor open circuit	$V_{CSP} - V_{CSN} > 300\text{ mV}$	FAULT pin pull low. The device stops switching and recovers when fault is removed.
Sense-resistor short circuit	COMP pin is clamped high	FAULT pin pull low. The device keeps switching under the cycle-by-cycle current limit.
Switching FET open circuit	COMP pin is clamped high	FAULT pin pull low. The device stops switching and recovers when fault is removed.
Switching FET short circuit	$V_{CSP} - V_{CSN} > 300\text{ mV}$	FAULT pin pull low. The device stops switching and recovers when fault is removed.
Thermal shutdown	$T_J > T_{TSD}$	FAULT pin pull low. The device stops switching and recovers when $T_J$ falls below the hysteresis level.

### 8.3.8 Thermal Foldback

The TPS92205x family integrates thermal shutdown protection to prevent the device from overheating. In order to provide design margin of system thermal performance, the device enables a programmable thermal foldback function which automatically reduces the full-scale max output current,  $I_{MAX}$ , at high junction temperature. When the device along with the LEDs are mounted on the same thermal substrate, the thermal performance is effectively improved due to the reduction of dissipation need for both device and LED.

As the device junction temperature rises above the thermal foldback threshold temperature,  $T_{TH}$ , the full-scale max current starts to reduce following the current-temperature curve shown in the below figure. The current starts to reduce from the 100% level at typically rate of 2% of  $I_{MAX}$  per °C until it drops to 50% of the full scale. Once the junction temperature rises 25°C above the  $T_{TH}$ , the current continues to decrease at a lower rate until the temperature reaches above the overtemperature shutdown threshold temperature,  $T_{TSD}$ .

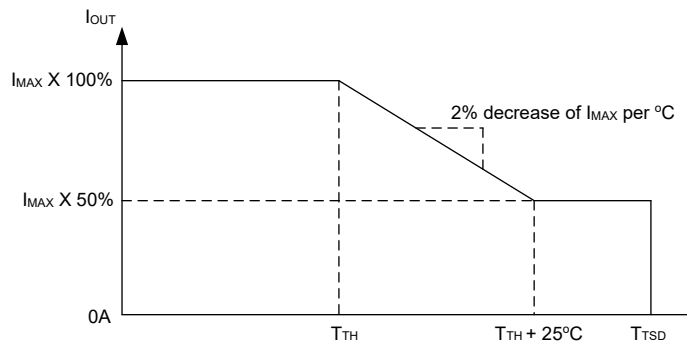

**Figure 8-6. Thermal Foldback**

The  $T_{TH}$  can be adjusted by changing the resistor  $R_{TEMP}$  connected between the TEMP and AGND pin. The  $T_{TH}$  and the corresponding  $R_{TEMP}$  value are listed in below table.

**Table 8-4.  $T_{TH}$  vs.  $R_{TEMP}$  resistor value**

$T_{TH}$ (°C)	Resistor Value (kΩ)
80	200
90	100
100	60
110	40
120	28
130	20
140	15
150	10

## 9 Application and Implementation

### 9.1 Application Information

The TPS92205x family is typically used as a Buck converter to drive one or more LEDs from an input from 4.5-V to 63-V range.

### 9.2 Typical Application

#### 9.2.1 TPS922054 24-V Input, 4-A Output, 4-piece WLED Driver With Analog Dimming

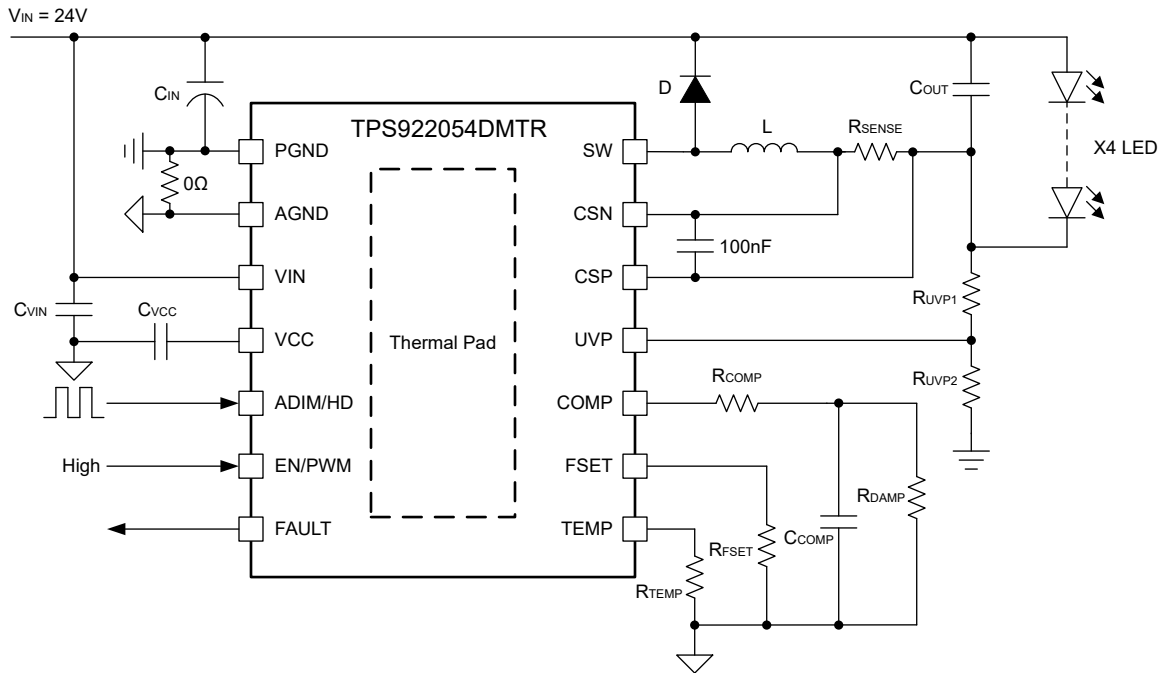

**Figure 9-1. 24-V Input, 4-A Output, 4-piece WLED, Analog Dimming Reference Design**

#### 9.2.1.1 Design Requirements

For this design example, use the parameters in the following table.

**Table 9-1. Design Parameters**

PARAMETER	VALUE
Input voltage range	24 V $\pm$ 10%
LED forward voltage	3.0 V
Output voltage	12 V (3.0 $\times$ 4)
Maximum LED current	4 A
Inductor current ripple	30% of maximum inductor current
LED current ripple	200 mA or less
Input voltage ripple	300 mV or less
Dimming type	Analog dimming with TPS922054: 1-kHz, 1% to 100% PWM input at the ADIM pin

## 9.2.1.2 Detailed Design Procedure

### 9.2.1.2.1 Inductor Selection

For this design, the input voltage is a 24-V, rail with 10% variation. The output is 4 white LEDs in series and the inductor current ripple by requirement is less than 30% of maximum inductor current. To choose a proper peak-to-peak inductor current ripple, the low-side FET current limit should not be violated when the converter works in full-load condition. This requires half of the peak-to-peak inductor current ripple to be lower than that limit. Another consideration is to ensure reasonable inductor core loss and copper loss caused by the peak-to-peak current ripple. Once this peak-to-peak inductor current ripple is chosen, use [Equation 2](#) to calculate the recommended value of the output inductor L.

$$L = \frac{V_{OUT} \times (V_{IN(max)} - V_{OUT})}{V_{IN(max)} \times K_{IND} \times I_{L(max)} \times f_{SW}} \quad (2)$$

where

- $K_{IND}$  is a coefficient that represents the amount of inductor ripple current relative to the maximum LED current.
- $I_{L(max)}$  is the maximum inductor current.
- $f_{SW}$  is the switching frequency.
- $V_{IN(max)}$  is the maximum input voltage.
- $V_{OUT}$  is the sum of the voltage across LED load and the voltage across sense resistor.

With the chosen inductor value, the user can calculate the actual inductor current ripple using [Equation 3](#).

$$I_{L(ripple)} = \frac{V_{OUT} \times (V_{IN(max)} - V_{OUT})}{V_{IN(max)} \times L \times f_{SW}} \quad (3)$$

The ratings of inductor RMS current and saturation current must be greater than those seen in the system requirement. This is to ensure no inductor overheat or saturation occurring. During power up, transient conditions or fault conditions, the inductor current may exceed its normal operating current and reach the current limit. Therefore, it is preferred to select a saturation current rating equal to or greater than the converter current limit. The peak-inductor-current and RMS current equations are shown in [Equation 4](#) and [Equation 5](#).

$$I_{L(peak)} = I_{L(max)} + \frac{I_{L(ripple)}}{2} \quad (4)$$

$$I_{L(rms)} = \sqrt{I_{L(max)}^2 + \frac{I_{L(ripple)}^2}{12}} \quad (5)$$

In this design,  $V_{IN(max)} = 24$  V,  $V_{OUT} = 12$  V,  $I_{LED} = 4$  A,  $f_{SW} = 400$  kHz, choose  $K_{IND} = 0.3$ , the calculated inductance is 12.5  $\mu$ H. A 15- $\mu$ H inductor is chosen. With this inductor, the ripple, peak, and rms currents of the inductor are 1 A, 4.5 A, and 4.01 A, respectively.

### 9.2.1.2.2 Input Capacitor Selection

An input capacitor is required to reduce the surge current drawn from the input supply and the switching noise coming from the device. Electrolytic capacitors are recommended for energy storage. Ceramic capacitors with X5R or X7R dielectrics are highly recommended because of their low ESR and small temperature coefficients. For most applications, it is recommended to place a 10- $\mu$ F ceramic capacitor along with a 0.1- $\mu$ F capacitor from VIN to PGND/AGND to provide high-frequency filtering. The input capacitor voltage rating must be greater than the maximum input voltage. Use [Equation 6](#) to calculate the input ripple voltage, where  $ESR_{CIN}$  is the ESR of input capacitor, and  $K_{DR}$  is the derating coefficient of ceramic capacitance at the applied DC voltage.

$$V_{IN(ripple)} = I_{L(max)} \times \left( \frac{V_{OUT}}{K_{DR} \times C_{IN} \times f_{SW} \times V_{IN(max)}} + ESR_{CIN} \right) \quad (6)$$

In this design, a 68- $\mu\text{F}$ , 100V electrolytic capacitor, a 22- $\mu\text{F}$ , 100V X7R ceramic capacitor and a 0.1- $\mu\text{F}$ , 100V X7R ceramic capacitor are chosen, yielding around 240-mV input ripple voltage.

### 9.2.1.2.3 Output Capacitor Selection

The output capacitor reduces the high-frequency current ripple through the LED string. Excessive current ripple increases the RMS current in the LED string, therefore increasing the LED temperature.

1. Calculate the total dynamic resistance of the LED string ( $R_{LED}$ ) using the LED manufacturer's datasheet.
2. Calculate the required impedance of the output capacitor ( $Z_{OUT}$ ) given the acceptable peak-to-peak ripple current through the LED string,  $I_{LED(ripple)}$ .  $I_{L(ripple)}$  is the peak-to-peak inductor ripple current as calculated with the selected inductor.
3. Calculate the minimum effective output capacitance required.
4. Increase the output capacitance appropriately due to the derating effect of applied DC voltage.

See [Equation 7](#), [Equation 8](#), and [Equation 9](#).

$$R_{LED} = \frac{\Delta V_F}{\Delta I_F} \times \# \text{ of LEDs} \quad (7)$$

$$Z_{COUT} = \frac{R_{LED} \times I_{LED(ripple)}}{I_{L(ripple)} - I_{LED(ripple)}} \quad (8)$$

$$C_{COUT} = \frac{1}{2\pi \times f_{SW} \times Z_{COUT}} \quad (9)$$

Once the output capacitor is chosen, [Equation 10](#) can be used to estimate the peak-to-peak ripple current through the LED string.

$$I_{LED(ripple)} = \frac{Z_{COUT} \times I_{L(ripple)}}{Z_{COUT} + R_{LED}} \quad (10)$$

CREE WLED is used here. The dynamic resistance of the LED is 0.67 ohm at 3-A forward current. Ceramic capacitors with X5R or X7R dielectrics are highly recommended because of their low ESR and small temperature coefficients. In this design, a 2.2- $\mu\text{F}$ , 100-V X7R ceramic capacitor and a 0.1- $\mu\text{F}$ , 100-V X7R ceramic capacitor are chosen. The calculated ripple current of the LED is about 210 mA.

### 9.2.1.2.4 Sense Resistor Selection

The maximum LED current is 4 A at 100% PWM duty and the corresponding  $V_{REF}$  is 200 mV. By using [Equation 1](#), the sense resistance is calculated as 50 m $\Omega$ .

Note that the power consumption of the sense resistor is 800 mW, requiring enough margin of the resistor's power rating in selection.

### 9.2.1.2.5 Other External Components Selection

In this design, a 0.1- $\mu\text{F}$ , 50-V X7R ceramic capacitor is chosen for high-frequency filtering of sense feedback.

For loop stability, it is recommended to select a 1-nF, 10-V X7R ceramic capacitor for  $C_{COMP}$ . A 1-M $\Omega$  resistor is chosen for  $R_{DAMP}$  to suppress the overshoot current at rising edge of PWM on.

### 9.2.1.3 Application Curves

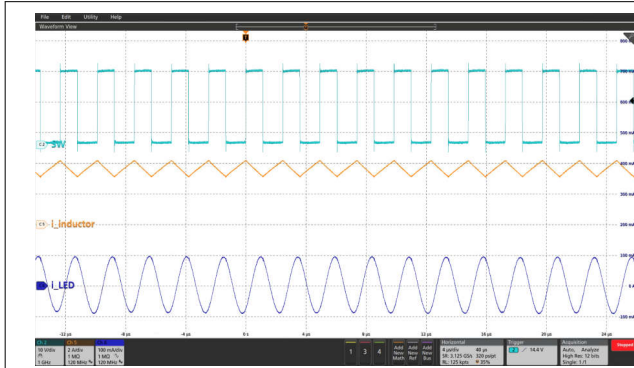

Light Blue: SW, Orange: Inductor Current, Deep Blue: LED Current Ripple (AC)

**Figure 9-2. LED Current Ripple at  $PWM_{ADIM} = 100\%$ , 1 kHz and  $F_{SW} = 400$  kHz**

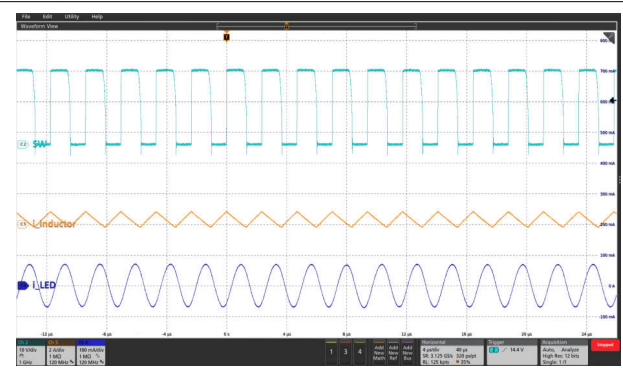

Light Blue: SW, Orange: Inductor Current, Deep Blue: LED Current Ripple (AC)

**Figure 9-3. LED Current Ripple at  $PWM_{ADIM} = 10\%$ , 1 kHz and  $F_{SW} = 400$  kHz**

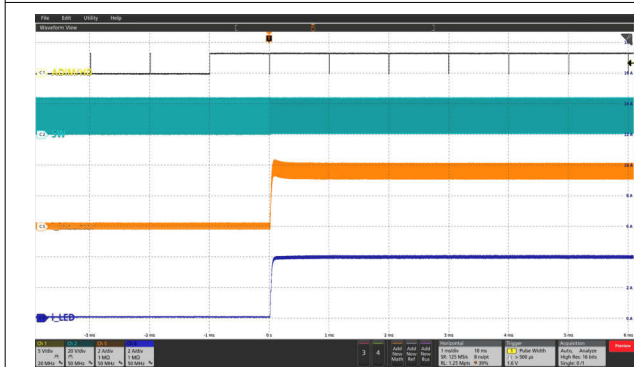

Black:  $PWM_{ADIM}$ , Light Blue: SW, Orange: Inductor Current, Deep Blue: LED Current

**Figure 9-4. LED Current Transient for a  $PWM_{ADIM}$  Transition from 1% to 99%, 1 kHz**

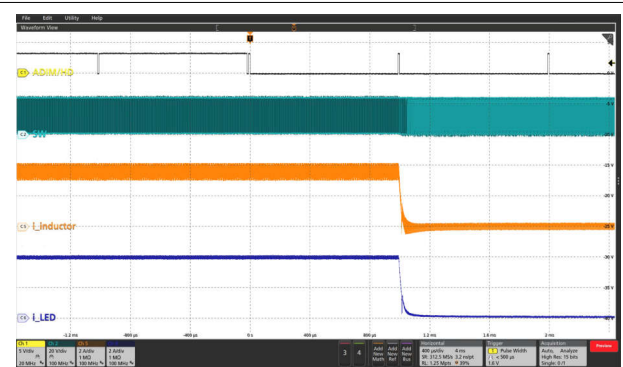

Black:  $PWM_{ADIM}$ , Light Blue: SW, Orange: Inductor Current, Deep Blue: LED Current

**Figure 9-5. LED Current Transient for a  $PWM_{ADIM}$  Transition from 99% to 1%, 1 kHz**

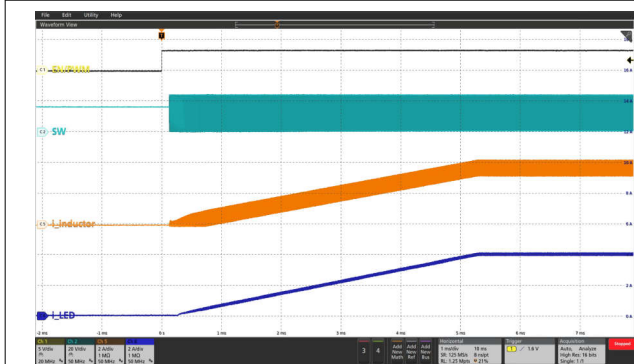

Black:  $PWM_{PWM}$ , Light Blue: SW, Orange: Inductor Current, Deep Blue: LED Current

**Figure 9-6. Start-Up at  $PWM_{ADIM} = 100\%$ , 1 kHz**

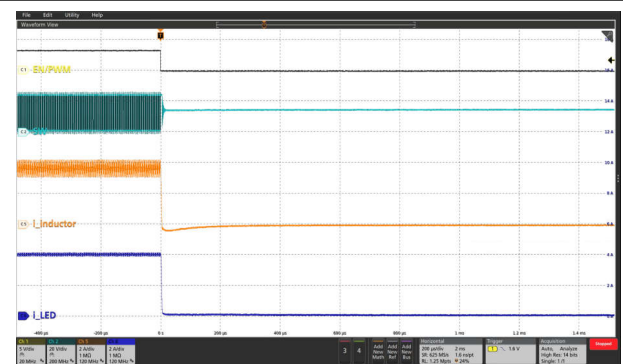

Black:  $PWM_{PWM}$ , Light Blue: SW, Orange: Inductor Current, Deep Blue: LED Current

**Figure 9-7. Shutdown at  $PWM_{ADIM} = 100\%$ , 1 kHz**



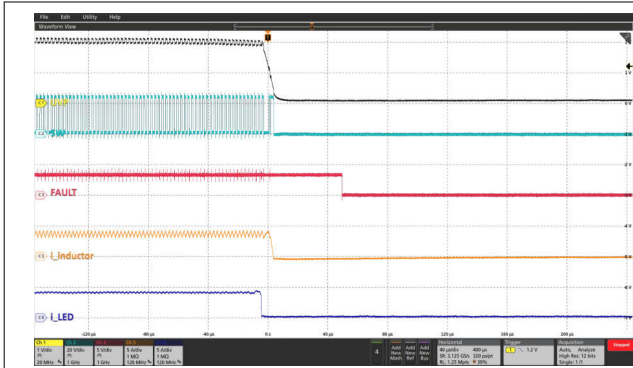

Black: UVP, Light Blue: SW, Red: FAULT, Orange: Inductor Current, Deep Blue: LED Current

**Figure 9-8. LED Open-Load Protection**

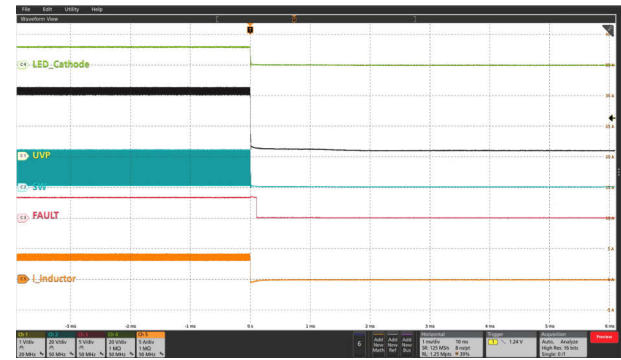

Black: UVP, Light Blue: SW, Red: FAULT, Orange: Inductor Current, Green: LED- Voltage

**Figure 9-9. LED- Short-to-PGND Protection**

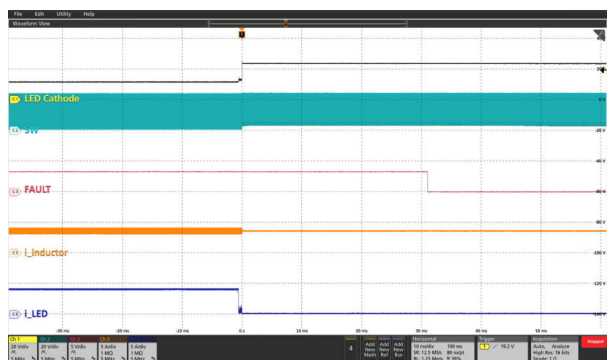

Black: LED- Voltage, Light Blue: SW, Red: FAULT, Orange: Inductor Current, Deep Blue: LED Current

**Figure 9-10. LED+ and LED- Short-Circuit Protection**

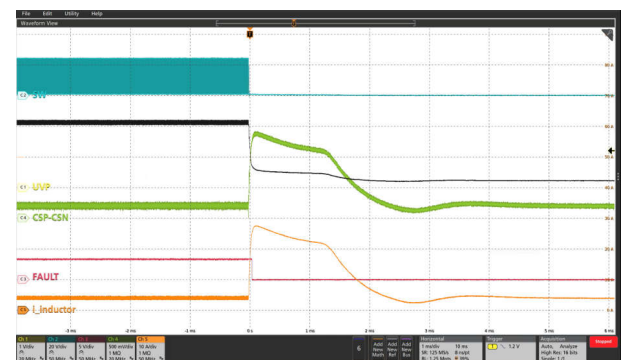

Black: UVP, Light Blue: SW, Red: FAULT, Orange: Inductor Current, Green: CSP-CSN

**Figure 9-11. Switching FET Short-Circuit Protection**

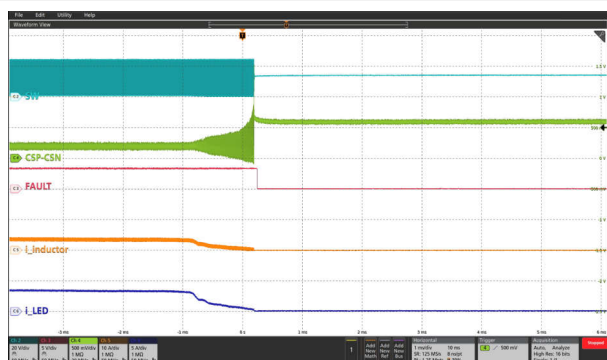

Light Blue: SW, Red: FAULT, Orange: Inductor Current, Deep Blue: LED Current, Green: CSP-CSN

**Figure 9-12. Sense-Resistor Open Protection**

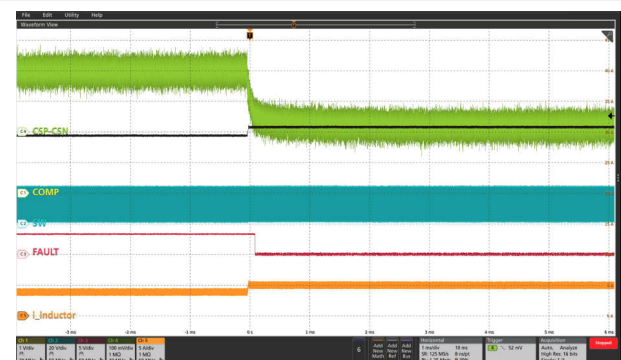

Black: COMP, Light Blue: SW, Red: FAULT, Orange: Inductor Current, Green: CSP-CSN

**Figure 9-13. Sense-Resistor Short-Circuit Protection**

## 9.2.2 TPS922054 48-V Input, 2-A Output, 12-piece WLED Driver with PWM Dimming

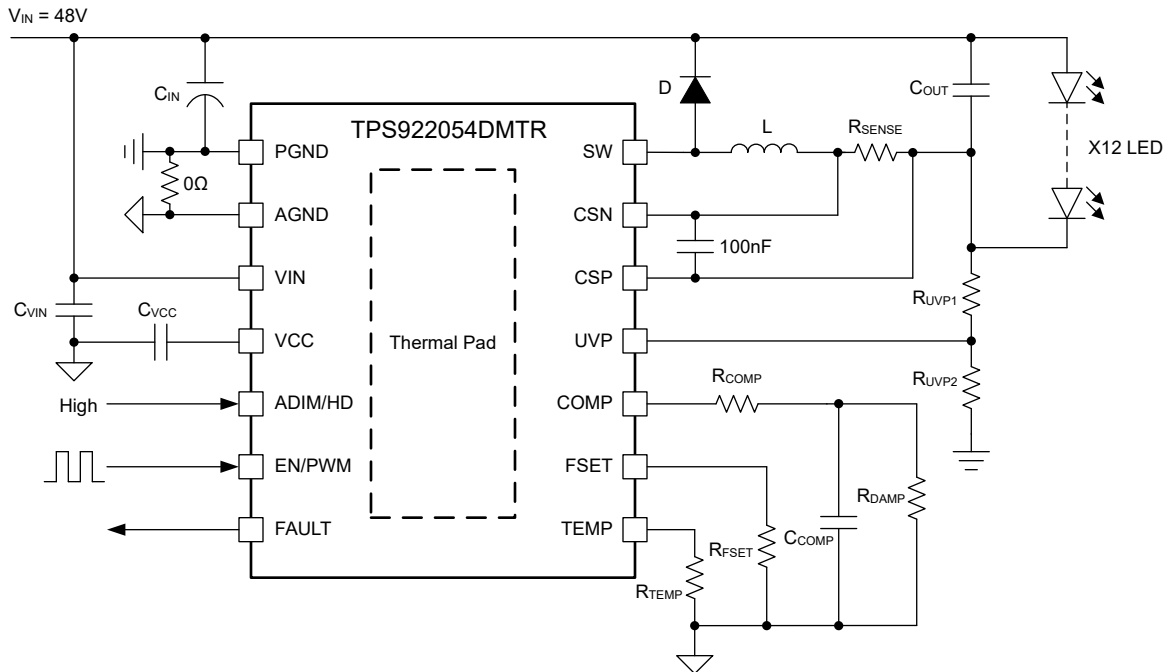

Figure 9-14. 48-V Input, 2-A Output, 12-piece WLED, PWM Dimming Reference Design

### 9.2.2.1 Design Requirements

For this design example, use the parameters in the following table.

Table 9-2. Design Parameters

PARAMETER	VALUE
Input voltage range	48 V $\pm$ 10%
LED forward voltage	3.0 V
Output voltage	36 V (3.0 $\times$ 12)
Maximum LED current	2 A
Inductor current ripple	40% of maximum inductor current
LED current ripple	200 mA or less
Input voltage ripple	600 mV or less
Dimming type	PWM dimming with TPS922054: 20-kHz, 1% to 100% PWM input at the PWM pin

### 9.2.2.2 Detailed Design Procedure

#### 9.2.2.2.1 Inductor Selection

For this design, the input voltage is a 48-V, rail with 10% variation. The output is 12 white LEDs in series and the inductor current ripple by requirement is less than 40% of maximum inductor current. To choose a proper peak-to-peak inductor current ripple, the low-side FET current limit should not be violated when the converter works in no-load condition. This requires half of the peak-to-peak inductor current ripple to be lower than that limit. Another consideration is to ensure reasonable inductor core loss and copper loss caused by the peak-to-peak current ripple. Once this peak-to-peak inductor current ripple is chosen, use [Equation 11](#) to calculate the recommended value of the output inductor L.

$$L = \frac{V_{OUT} \times (V_{IN(max)} - V_{OUT})}{V_{IN(max)} \times K_{IND} \times I_{L(max)} \times f_{SW}} \quad (11)$$

where

- $K_{IND}$  is a coefficient that represents the amount of inductor ripple current relative to the maximum LED current.
- $I_{L(max)}$  is the maximum inductor current.
- $f_{SW}$  is the switching frequency.
- $V_{IN(max)}$  is the maximum input voltage.
- $V_{OUT}$  is the sum of the voltage across LED load and the voltage across sense resistor.

With the chosen inductor value, the user can calculate the actual inductor current ripple using [Equation 12](#).

$$I_{L(ripple)} = \frac{V_{OUT} \times (V_{IN(max)} - V_{OUT})}{V_{IN(max)} \times L \times f_{SW}} \quad (12)$$

The ratings of inductor RMS current and saturation current must be greater than those seen in the system requirement. This is to ensure no inductor overheat or saturation occurring. During power up, transient conditions or fault conditions, the inductor current may exceed its normal operating current and reach the current limit. Therefore, it is preferred to select a saturation current rating equal to or greater than the converter current limit. The peak-inductor-current and RMS current equations are shown in [Equation 13](#) and [Equation 14](#).

$$I_{L(peak)} = I_{L(max)} + \frac{I_{L(ripple)}}{2} \quad (13)$$

$$I_{L(rms)} = \sqrt{I_{L(max)}^2 + \frac{I_{L(ripple)}^2}{12}} \quad (14)$$

In this design,  $V_{IN(max)} = 48$  V,  $V_{OUT} = 36$  V,  $I_{LED} = 2$  A,  $f_{SW} = 1.2$  MHz, choose  $K_{IND} = 0.4$ , the calculated inductance is 9.4  $\mu$ H. A 10- $\mu$ H inductor is chosen. With this inductor, the ripple, peak, and rms currents of the inductor are 0.75 A, 2.4 A, and 2.01 A, respectively.

#### 9.2.2.2.2 Input Capacitor Selection

An input capacitor is required to reduce the surge current drawn from the input supply and the switching noise coming from the device. Electrolytic capacitors are recommended for energy storage. Ceramic capacitors with X5R or X7R dielectrics are highly recommended because of their low ESR and small temperature coefficients. For most applications, it is recommended to place a 10- $\mu$ F capacitor along with a 0.1- $\mu$ F capacitor from VIN to PGND/AGND to provide high-frequency filtering. The input capacitor voltage rating must be greater than the maximum input voltage. Use [Equation 15](#) to calculate the input ripple voltage, where  $ESR_{CIN}$  is the ESR of input capacitor, and  $K_{DR}$  is the derating coefficient of ceramic capacitance at the applied DC voltage.

$$V_{IN(ripple)} = I_{L(max)} \times \left( \frac{V_{OUT}}{K_{DR} \times C_{IN} \times f_{SW} \times V_{IN(max)}} + ESR_{CIN} \right) \quad (15)$$

In this design, a 10-μF, 100V electrolytic capacitor, a 2.2-μF, 100V X7R ceramic capacitor and a 0.1-μF, 100V X7R ceramic capacitor are chosen, yielding around 570-mV input ripple voltage.

### 9.2.2.2.3 Output Capacitor Selection

The output capacitor reduces the high-frequency current ripple through the LED string. Excessive current ripple increases the RMS current in the LED string, therefore increasing the LED temperature.

1. Calculate the total dynamic resistance of the LED string ( $R_{LED}$ ) using the LED manufacturer's datasheet.
2. Calculate the required impedance of the output capacitor ( $Z_{COUT}$ ) given the acceptable peak-to-peak ripple current through the LED string,  $I_{LED(ripple)}$ .  $I_{L(ripple)}$  is the peak-to-peak inductor ripple current as calculated with the selected inductor.
3. Calculate the minimum effective output capacitance required.
4. Increase the output capacitance appropriately due to the derating effect of applied DC voltage.

See [Equation 16](#), [Equation 17](#), and [Equation 18](#).

$$R_{LED} = \frac{\Delta V_F}{\Delta I_F} \times \# \text{ of LEDs} \quad (16)$$

$$Z_{COUT} = \frac{R_{LED} \times I_{LED(ripple)}}{I_{L(ripple)} - I_{LED(ripple)}} \quad (17)$$

$$C_{COUT} = \frac{1}{2\pi \times f_{SW} \times Z_{COUT}} \quad (18)$$

Once the output capacitor is chosen, [Equation 19](#) can be used to estimate the peak-to-peak ripple current through the LED string.

$$I_{LED(ripple)} = \frac{Z_{COUT} \times I_{L(ripple)}}{Z_{COUT} + R_{LED}} \quad (19)$$

Cree WLED is used here. The dynamic resistance of the LED is 0.67 ohm at 1-A forward current. Ceramic capacitors with X5R or X7R dielectrics are highly recommended because of their low ESR and small temperature coefficients. In this design, a 1-μF, 100-V X7R ceramic capacitor and a 0.1-μF, 100-V X7R ceramic capacitor are chosen. The calculated ripple current of the LED is about 120 mA.

### 9.2.2.2.4 Sense Resistor Selection

The maximum LED current is 2 A at 100% PWM duty and the corresponding  $V_{REF}$  is 200 mV. By using [Equation 1](#), the sense resistance is calculated as 100 mΩ.

Note that the power consumption of the sense resistor is 400 mW, requiring enough margin of the resistor's power rating in selection.

### 9.2.2.2.5 Other External Components Selection

In this design, a 0.1-μF, 50-V X7R ceramic capacitor is chosen for high-frequency filtering of sense feedback.

For loop stability, it is recommended to select a 1-nF, 10-V X7R ceramic capacitor for  $C_{COMP}$ . A 1-MΩ resistor is chosen for  $R_{DAMP}$  to suppress the overshoot current at rising edge of PWM on.

### 9.2.2.3 Application Curves

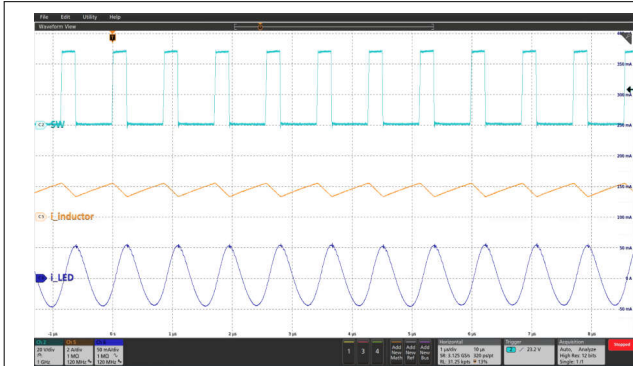

Light Blue: SW, Orange: Inductor Current, Deep Blue: LED Current Ripple (AC)

**Figure 9-15. LED Current Ripple at  $PWM_{ADIM} = 100\%$ , 1 kHz and  $F_{SW} = 1.2$  MHz**

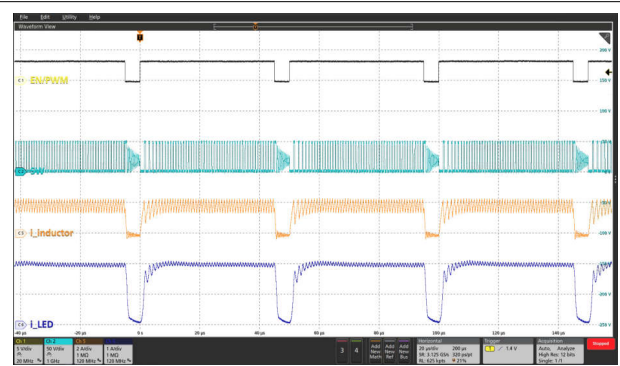

Black:  $PWM_{PWM}$ , Light Blue: SW, Orange: Inductor Current, Deep Blue: LED Current

**Figure 9-16. LED PWM Dimming at  $PWM_{PWM} = 90\%$ , 20 kHz**

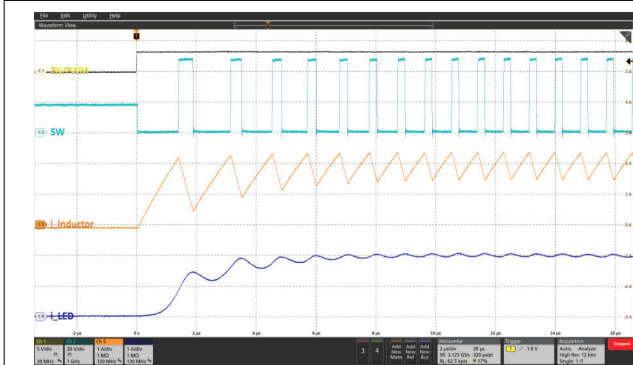

Black:  $PWM_{PWM}$ , Light Blue: SW, Orange: Inductor Current, Deep Blue: LED Current

**Figure 9-17. LED PWM Dimming Rising Edge at  $PWM_{PWM} = 50\%$ , 20 kHz**

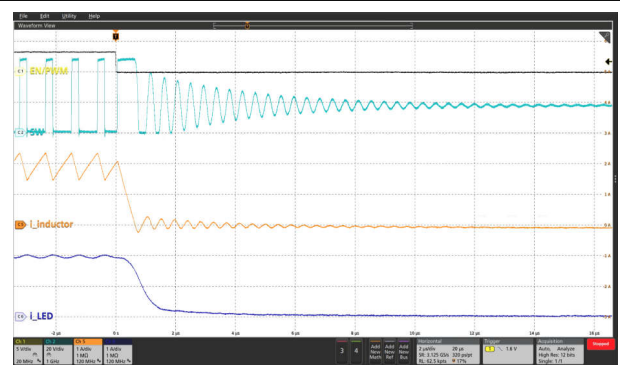

Black:  $PWM_{PWM}$ , Light Blue: SW, Orange: Inductor Current, Deep Blue: LED Current

**Figure 9-18. LED PWM Dimming Falling Edge at  $PWM_{PWM} = 50\%$ , 20 kHz**

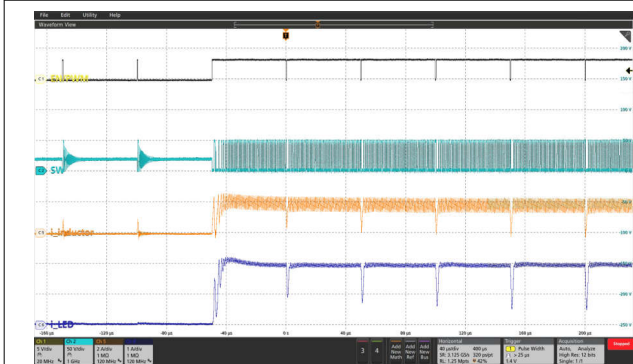

Black:  $PWM_{PWM}$ , Light Blue: SW, Orange: Inductor Current, Deep Blue: LED Current

**Figure 9-19. LED Current Transient for a  $PWM_{PWM}$  Transition from 1% to 99%, 20 kHz**

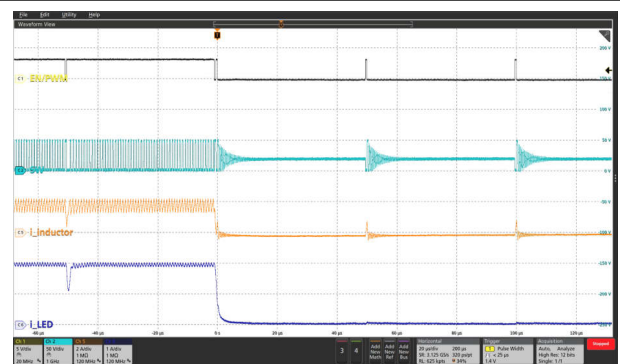

Black:  $PWM_{PWM}$ , Light Blue: SW, Orange: Inductor Current, Deep Blue: LED Current

**Figure 9-20. LED Current Transient for a  $PWM_{PWM}$  Transition from 99% to 1%, 20 kHz**

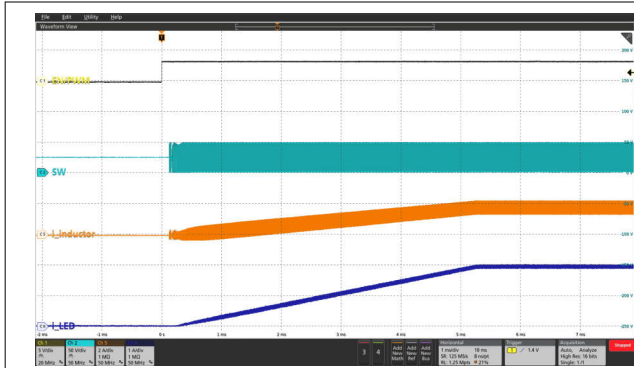

Black: PWM<sub>PWM</sub>, Light Blue: SW, Orange: Inductor Current,  
Deep Blue: LED Current

**Figure 9-21. Start-Up at PWM<sub>PWM</sub> = 100%, 20 kHz**

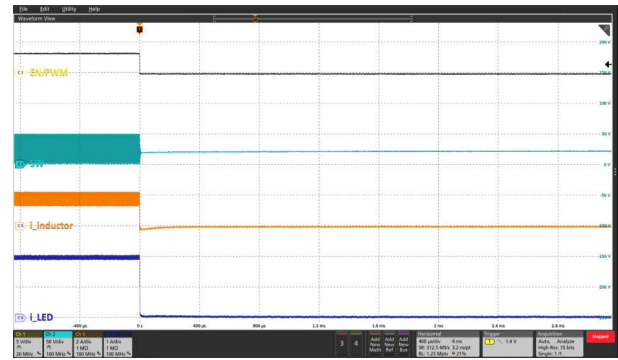

Black: PWM<sub>PWM</sub>, Light Blue: SW, Orange: Inductor Current,  
Deep Blue: LED Current

**Figure 9-22. Shutdown at PWM<sub>PWM</sub> = 100%, 20 kHz**

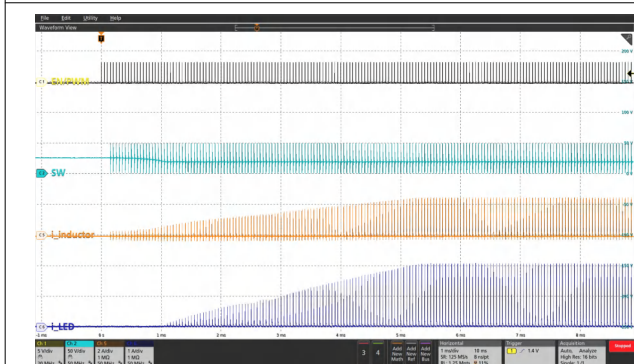

Black: PWM<sub>PWM</sub>, Light Blue: SW, Orange: Inductor Current,  
Deep Blue: LED Current

**Figure 9-23. Start-Up at PWM<sub>PWM</sub> = 10%, 20 kHz**

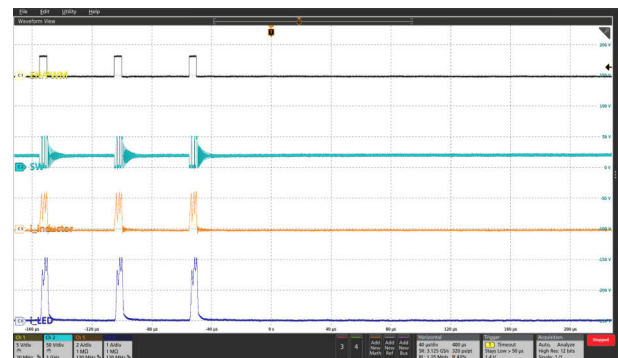

Black: PWM<sub>PWM</sub>, Light Blue: SW, Orange: Inductor Current,  
Deep Blue: LED Current

**Figure 9-24. Shutdown at PWM<sub>PWM</sub> = 10%, 20 kHz**

## 9.3 Power Supply Recommendations

The device is designed to operate from an input voltage supply ranging between 4.5 V and 65 V. This input supply must be well regulated. The device requires an input capacitor to reduce the surge current drawn from the input supply and the switching noise from the device. Ceramic capacitors with X5R or X7R dielectrics are highly recommended because of their low ESR and small temperature coefficients. For most applications, a 10- $\mu$ F capacitor is enough.

## 9.4 Layout

The TPS92205x family requires a proper layout for optimal performance. The following section gives some guidelines to ensure a proper layout.

### 9.4.1 Layout Guidelines

An example of a proper layout for the TPS92205x family is shown in [Section 9.4.2](#)

- Creating a large PGND plane for good electrical and thermal performance is important.
- The IN and PGND traces should be as wide as possible to reduce trace impedance. Wide traces have the additional advantage of providing excellent heat dissipation.
- Thermal vias can be used to connect the top-side PGND plane to additional printed-circuit board (PCB) layers for heat dissipation and grounding.
- The input capacitors must be located as close as possible to the IN pin and the PGND/AGND pin.
- The VCC capacitor should be placed as close as possible to VCC pin to ensure stable LDO output voltage.
- The SW trace must be kept as short as possible to reduce parasitic inductance and thereby reduce transient voltage spikes. Short SW trace also reduces radiated noise and EMI.
- Do not allow switching current to flow under the device.
- The routing of CSN and CSP traces are recommended to be in parallel and kept as short as possible and placed away from the high-voltage switching trace and the ground shield.
- The compensation capacitor must be placed as close as possible to COMP pin so as to prevent oscillation and system instability.

### 9.4.2 Layout Example

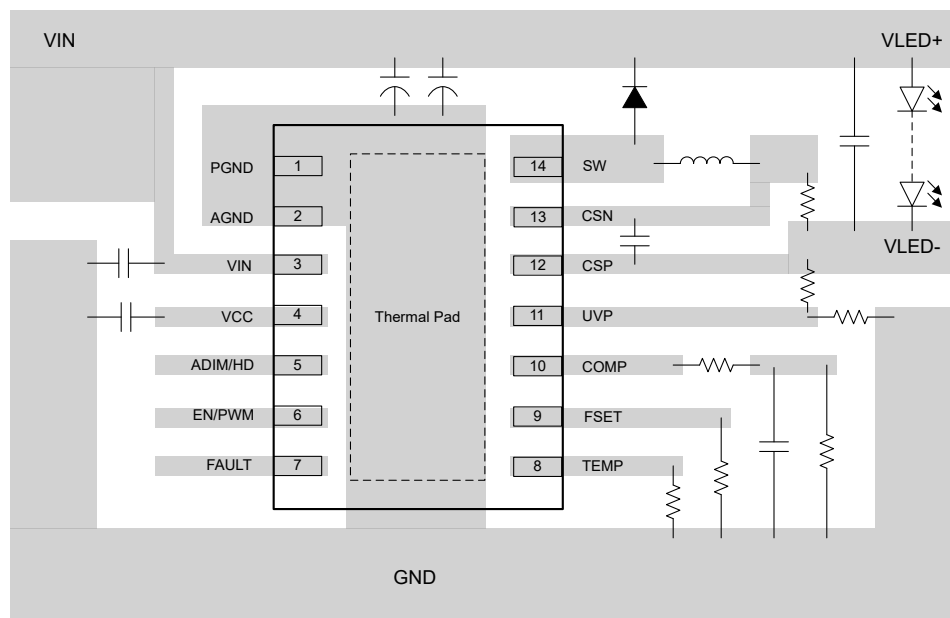

**Figure 9-25. 14-Pin VSON Top View Layout Example**

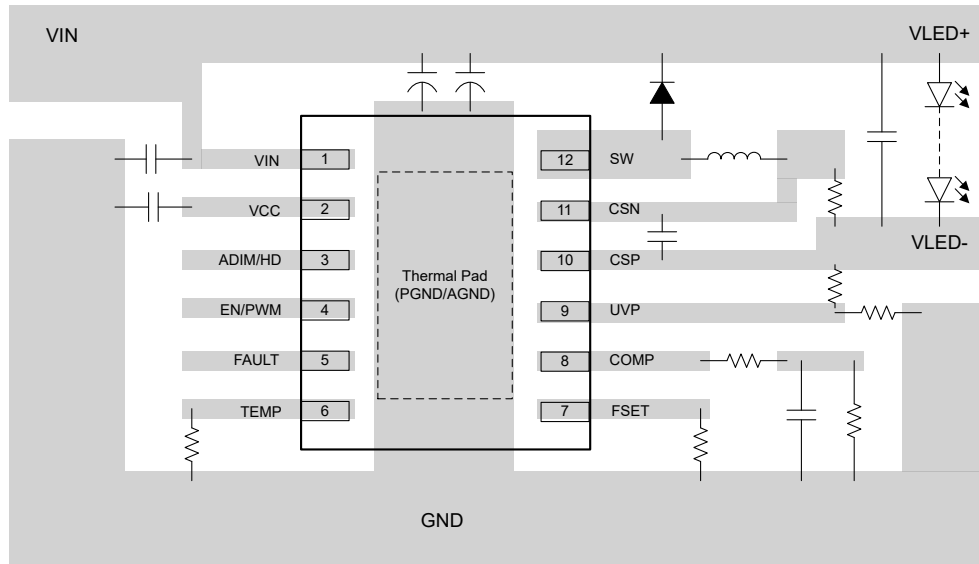

**Figure 9-26. 12-Pin WSON Top View Layout Example**

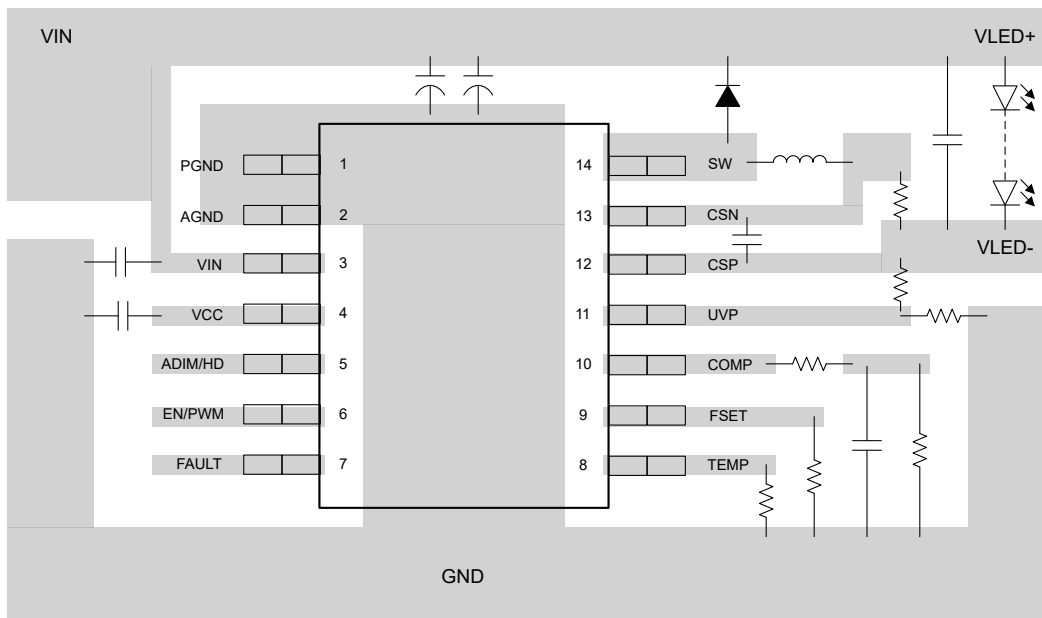

**Figure 9-27. 14-Pin SOT-23-TH Top View Layout Example**



## 10 Device and Documentation Support

### 10.1 Receiving Notification of Documentation Updates

To receive notification of documentation updates, navigate to the device product folder on [ti.com](https://www.ti.com). Click on *Subscribe to updates* to register and receive a weekly digest of any product information that has changed. For change details, review the revision history included in any revised document.

### 10.2 Support Resources

[TI E2E™ support forums](#) are an engineer's go-to source for fast, verified answers and design help — straight from the experts. Search existing answers or ask your own question to get the quick design help you need.

Linked content is provided "AS IS" by the respective contributors. They do not constitute TI specifications and do not necessarily reflect TI's views; see TI's [Terms of Use](#).

### 10.3 Trademarks

TI E2E™ is a trademark of Texas Instruments.  
All trademarks are the property of their respective owners.

### 10.4 Electrostatic Discharge Caution



This integrated circuit can be damaged by ESD. Texas Instruments recommends that all integrated circuits be handled with appropriate precautions. Failure to observe proper handling and installation procedures can cause damage.

ESD damage can range from subtle performance degradation to complete device failure. Precision integrated circuits may be more susceptible to damage because very small parametric changes could cause the device not to meet its published specifications.

### 10.5 Glossary

[TI Glossary](#) This glossary lists and explains terms, acronyms, and definitions.

## 11 Mechanical, Packaging, and Orderable Information

The following pages include mechanical, packaging, and orderable information. This information is the most-current data available for the designated devices. This data is subject to change without notice and without revision of this document. For browser-based versions of this data sheet, see the left-hand navigation pane.

**PACKAGING INFORMATION**

Orderable Device	Status (1)	Package Type	Package Drawing	Pins	Package Qty	Eco Plan (2)	Lead finish/ Ball material (6)	MSL Peak Temp (3)	Op Temp (°C)	Device Marking (4/5)	Samples
TPS922052DMTR	ACTIVE	VSON	DMT	14	3000	RoHS & Green	NIPDAU	Level-1-260C-UNLIM	-40 to 125	T2052	<a href="#">Samples</a>
TPS922052DRRR	ACTIVE	WSON	DRR	12	3000	RoHS & Green	NIPDAU	Level-1-260C-UNLIM	-40 to 125	T22052	<a href="#">Samples</a>
TPS922052DYR	ACTIVE	SOT-23-THIN	DYY	14	3000	RoHS & Green	NIPDAU	Level-1-260C-UNLIM	-40 to 125	T2052	<a href="#">Samples</a>
TPS922053DMTR	ACTIVE	VSON	DMT	14	3000	RoHS & Green	NIPDAU	Level-1-260C-UNLIM	-40 to 125	T2053	<a href="#">Samples</a>
TPS922053DRRR	ACTIVE	WSON	DRR	12	3000	RoHS & Green	NIPDAU	Level-1-260C-UNLIM	-40 to 125	T22053	<a href="#">Samples</a>
TPS922053DYR	ACTIVE	SOT-23-THIN	DYY	14	3000	RoHS & Green	NIPDAU	Level-1-260C-UNLIM	-40 to 125	T2053	<a href="#">Samples</a>
TPS922054DMTR	ACTIVE	VSON	DMT	14	3000	RoHS & Green	NIPDAU	Level-1-260C-UNLIM	-40 to 125	T2054	<a href="#">Samples</a>
TPS922054DRRR	ACTIVE	WSON	DRR	12	3000	RoHS & Green	NIPDAU	Level-1-260C-UNLIM	-40 to 125	T22054	<a href="#">Samples</a>
TPS922054MDMTR	ACTIVE	VSON	DMT	14	3000	RoHS & Green	NIPDAU	Level-1-260C-UNLIM	-55 to 125	T204M	<a href="#">Samples</a>
TPS922055DMTR	ACTIVE	VSON	DMT	14	3000	RoHS & Green	NIPDAU	Level-1-260C-UNLIM	-40 to 125	T2055	<a href="#">Samples</a>
TPS922055DRRR	ACTIVE	WSON	DRR	12	3000	RoHS & Green	NIPDAU	Level-1-260C-UNLIM	-40 to 125	T22055	<a href="#">Samples</a>
TPS922055MDMTR	ACTIVE	VSON	DMT	14	3000	RoHS & Green	NIPDAU	Level-1-260C-UNLIM	-55 to 125	T205M	<a href="#">Samples</a>

(1) The marketing status values are defined as follows:

**ACTIVE:** Product device recommended for new designs.

**LIFEBUY:** TI has announced that the device will be discontinued, and a lifetime-buy period is in effect.

**NRND:** Not recommended for new designs. Device is in production to support existing customers, but TI does not recommend using this part in a new design.

**PREVIEW:** Device has been announced but is not in production. Samples may or may not be available.

**OBSELETE:** TI has discontinued the production of the device.

(2) **RoHS:** TI defines "RoHS" to mean semiconductor products that are compliant with the current EU RoHS requirements for all 10 RoHS substances, including the requirement that RoHS substance do not exceed 0.1% by weight in homogeneous materials. Where designed to be soldered at high temperatures, "RoHS" products are suitable for use in specified lead-free processes. TI may reference these types of products as "Pb-Free".

**RoHS Exempt:** TI defines "RoHS Exempt" to mean products that contain lead but are compliant with EU RoHS pursuant to a specific EU RoHS exemption.

**Green:** TI defines "Green" to mean the content of Chlorine (Cl) and Bromine (Br) based flame retardants meet JS709B low halogen requirements of <=1000ppm threshold. Antimony trioxide based flame retardants must also meet the <=1000ppm threshold requirement.

- (3) MSL, Peak Temp. - The Moisture Sensitivity Level rating according to the JEDEC industry standard classifications, and peak solder temperature.
- (4) There may be additional marking, which relates to the logo, the lot trace code information, or the environmental category on the device.
- (5) Multiple Device Markings will be inside parentheses. Only one Device Marking contained in parentheses and separated by a "~" will appear on a device. If a line is indented then it is a continuation of the previous line and the two combined represent the entire Device Marking for that device.
- (6) Lead finish/Ball material - Orderable Devices may have multiple material finish options. Finish options are separated by a vertical ruled line. Lead finish/Ball material values may wrap to two lines if the finish value exceeds the maximum column width.

**Important Information and Disclaimer:**The information provided on this page represents TI's knowledge and belief as of the date that it is provided. TI bases its knowledge and belief on information provided by third parties, and makes no representation or warranty as to the accuracy of such information. Efforts are underway to better integrate information from third parties. TI has taken and continues to take reasonable steps to provide representative and accurate information but may not have conducted destructive testing or chemical analysis on incoming materials and chemicals. TI and TI suppliers consider certain information to be proprietary, and thus CAS numbers and other limited information may not be available for release.

In no event shall TI's liability arising out of such information exceed the total purchase price of the TI part(s) at issue in this document sold by TI to Customer on an annual basis.

## GENERIC PACKAGE VIEW

**DMT 14**

**VSON - 0.9 mm max height**

3 x 4.5, 0.65 mm pitch

PLASTIC SMALL OUTLINE - NO LEAD

This image is a representation of the package family, actual package may vary.  
Refer to the product data sheet for package details.

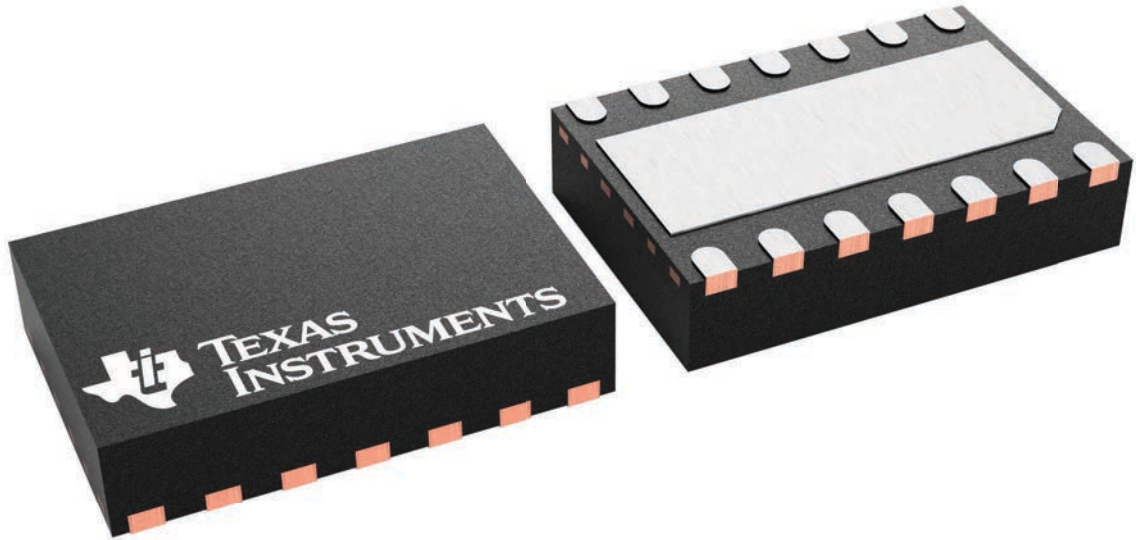

4225088/A

# DMT0014D

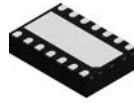

## PACKAGE OUTLINE

### VSON - 1 mm max height

PLASTIC SMALL OUTLINE - NO LEAD

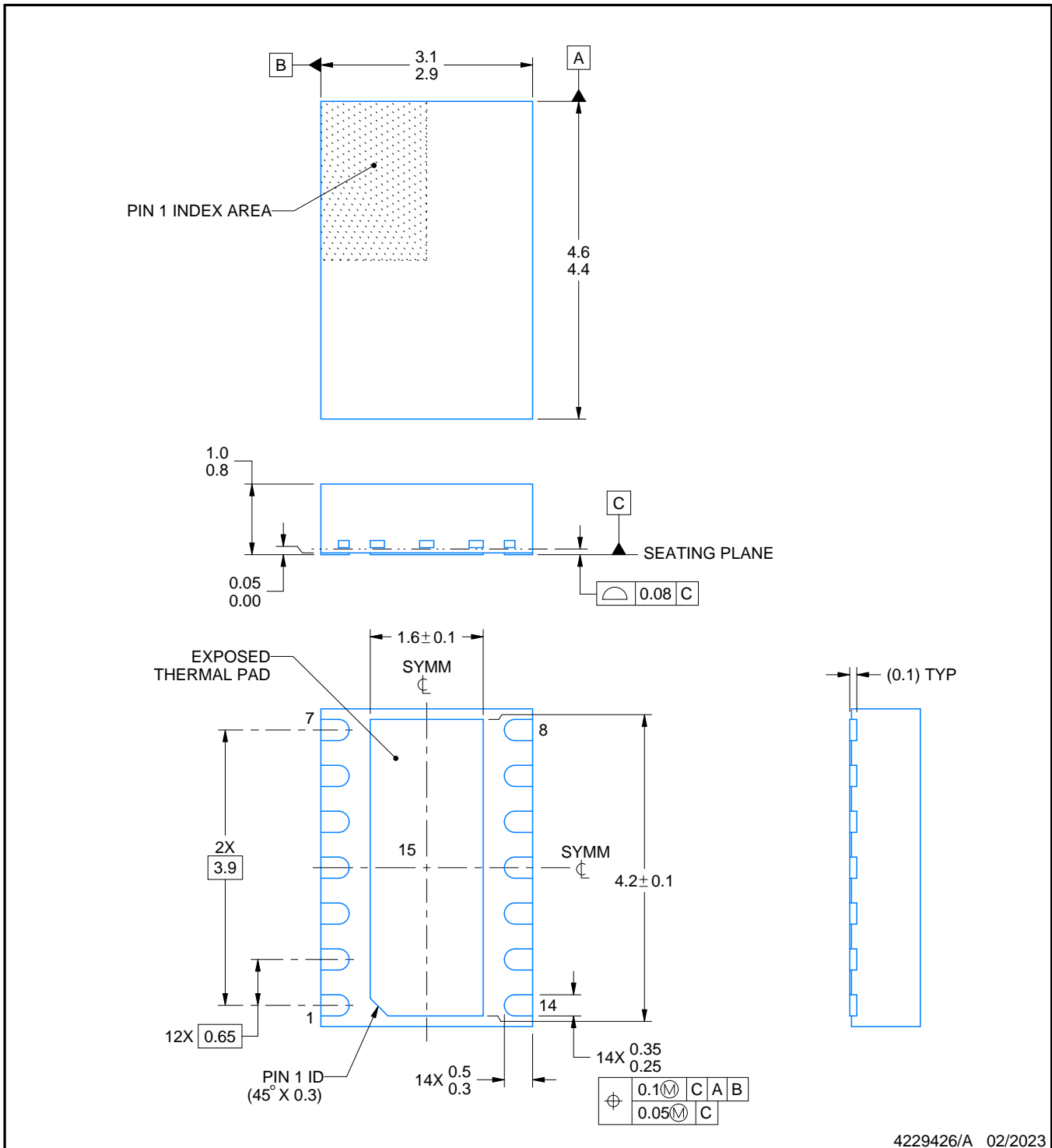

4229426/A 02/2023

#### NOTES:

1. All linear dimensions are in millimeters. Any dimensions in parenthesis are for reference only. Dimensioning and tolerancing per ASME Y14.5M.
2. This drawing is subject to change without notice.
3. The package thermal pad must be soldered to the printed circuit board for thermal and mechanical performance.

# EXAMPLE BOARD LAYOUT

DMT0014D

VSON - 1 mm max height

PLASTIC SMALL OUTLINE - NO LEAD

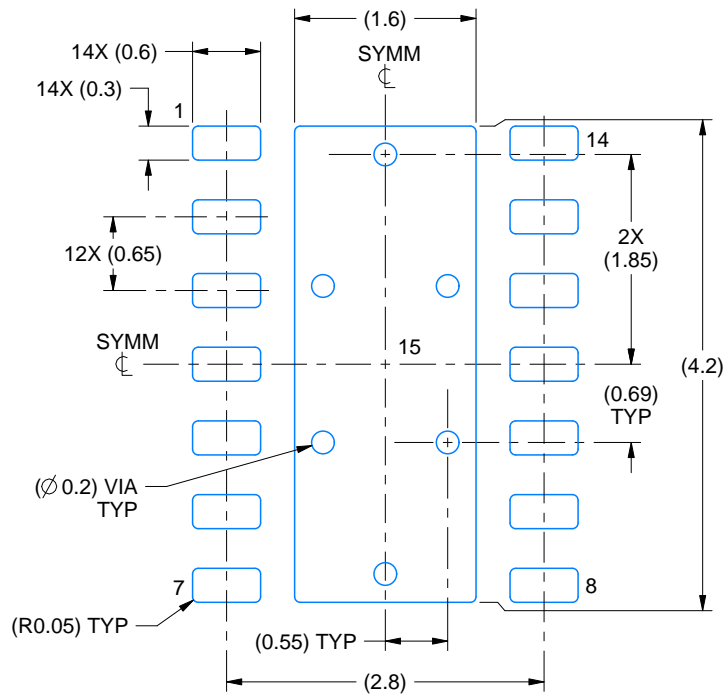

LAND PATTERN EXAMPLE  
EXPOSED METAL SHOWN  
SCALE:15X

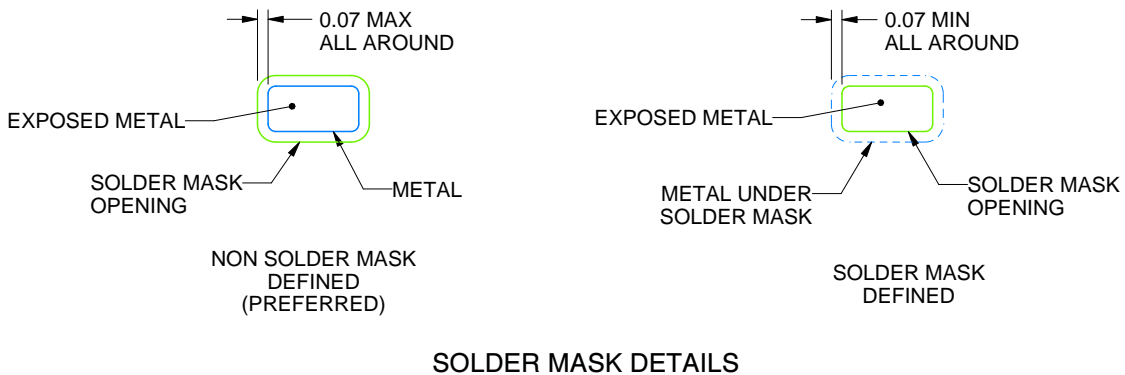

SOLDER MASK DETAILS

4229426/A 02/2023

NOTES: (continued)

4. This package is designed to be soldered to a thermal pad on the board. For more information, see Texas Instruments literature number SLUA271 ([www.ti.com/lit/slua271](http://www.ti.com/lit/slua271)).
5. Vias are optional depending on application, refer to device data sheet. If any vias are implemented, refer to their locations shown on this view. It is recommended that vias under paste be filled, plugged or tented.

# EXAMPLE STENCIL DESIGN

DMT0014D

VSON - 1 mm max height

PLASTIC SMALL OUTLINE - NO LEAD

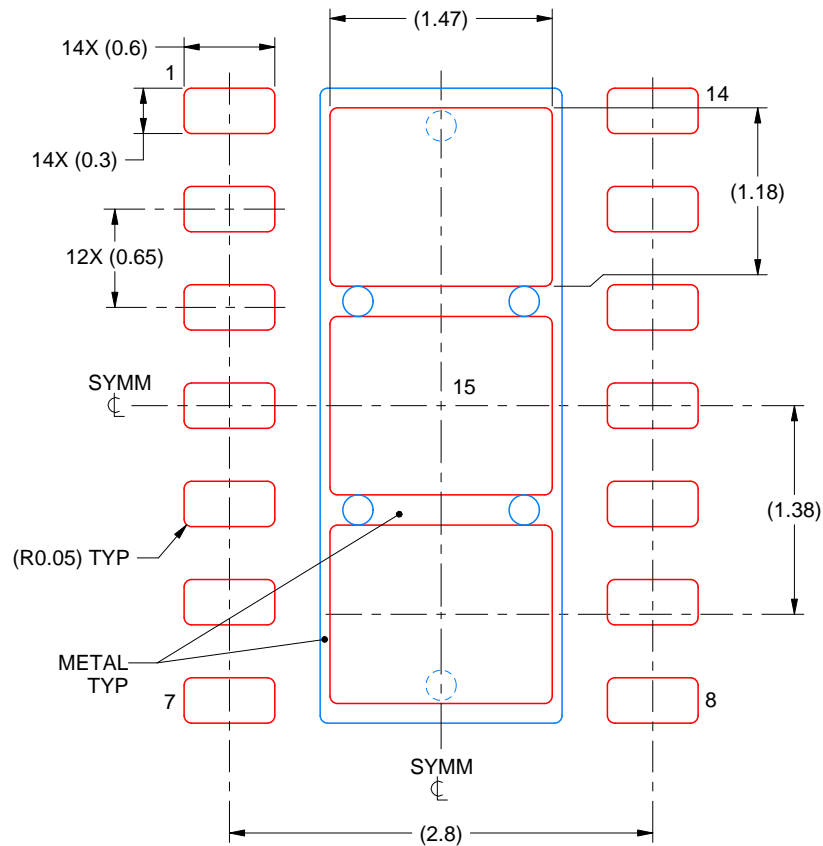

SOLDER PASTE EXAMPLE  
BASED ON 0.125 mm THICK STENCIL  
EXPOSED PAD 15  
77.4% PRINTED SOLDER COVERAGE BY AREA  
SCALE:20X

4229426/A 02/2023

NOTES: (continued)

6. Laser cutting apertures with trapezoidal walls and rounded corners may offer better paste release. IPC-7525 may have alternate design recommendations.

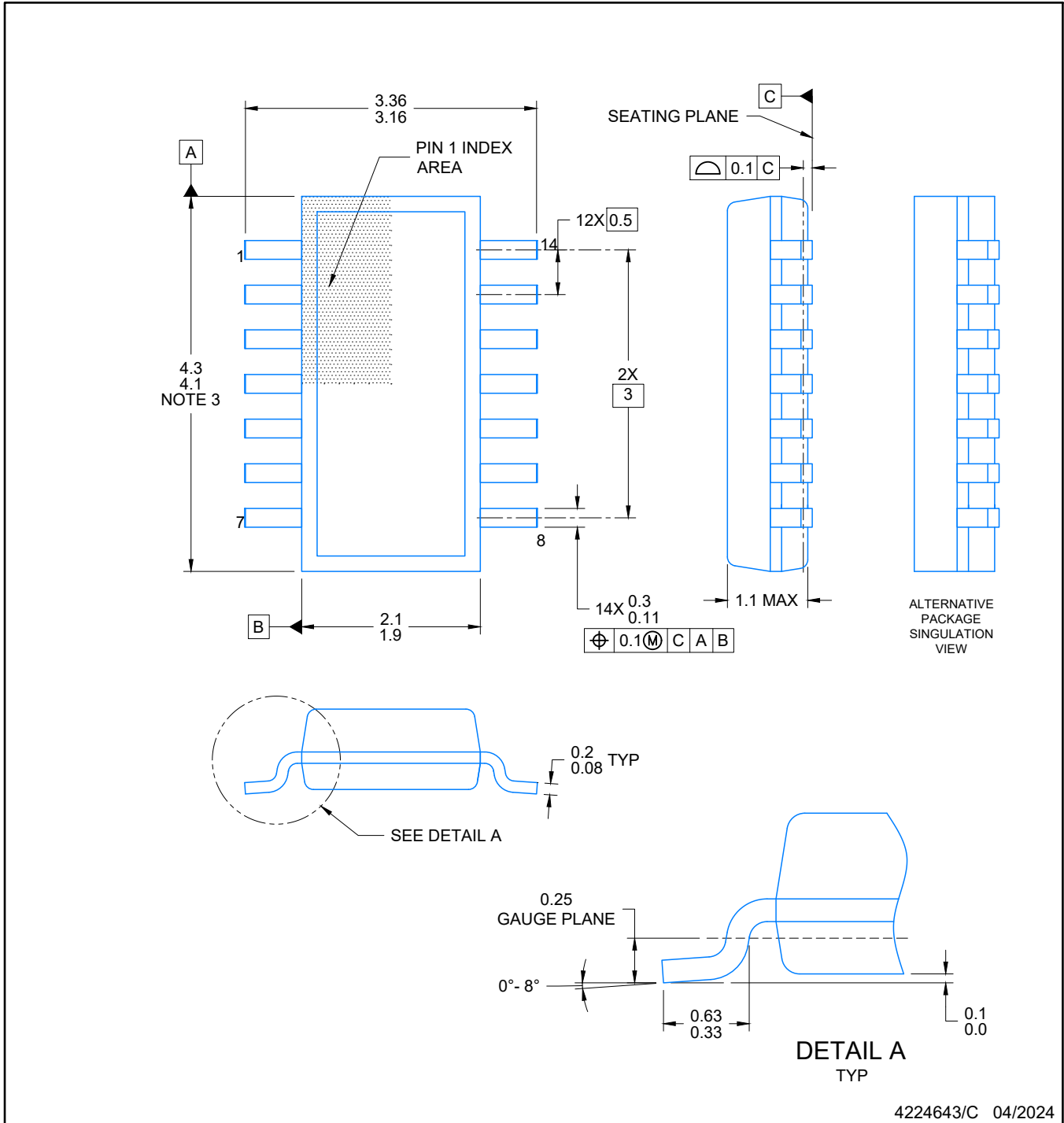

4224643/C 04/2024

NOTES:

1. All linear dimensions are in millimeters. Any dimensions in parenthesis are for reference only. Dimensioning and tolerancing per ASME Y14.5M.
2. This drawing is subject to change without notice.
3. This dimension does not include mold flash, protrusions, or gate burrs. Mold flash, protrusions, or gate burrs shall not exceed 0.15 per side.
4. This dimension does not include interlead flash. Interlead flash shall not exceed 0.50 per side.
5. Reference JEDEC Registration MO-345, Variation AB





LAND PATTERN EXAMPLE  
EXPOSED METAL SHOWN  
SCALE: 20X



4224643/C 04/2024

NOTES: (continued)

- 6. Publication IPC-7351 may have alternate designs.
- 7. Solder mask tolerances between and around signal pads can vary based on board fabrication site.

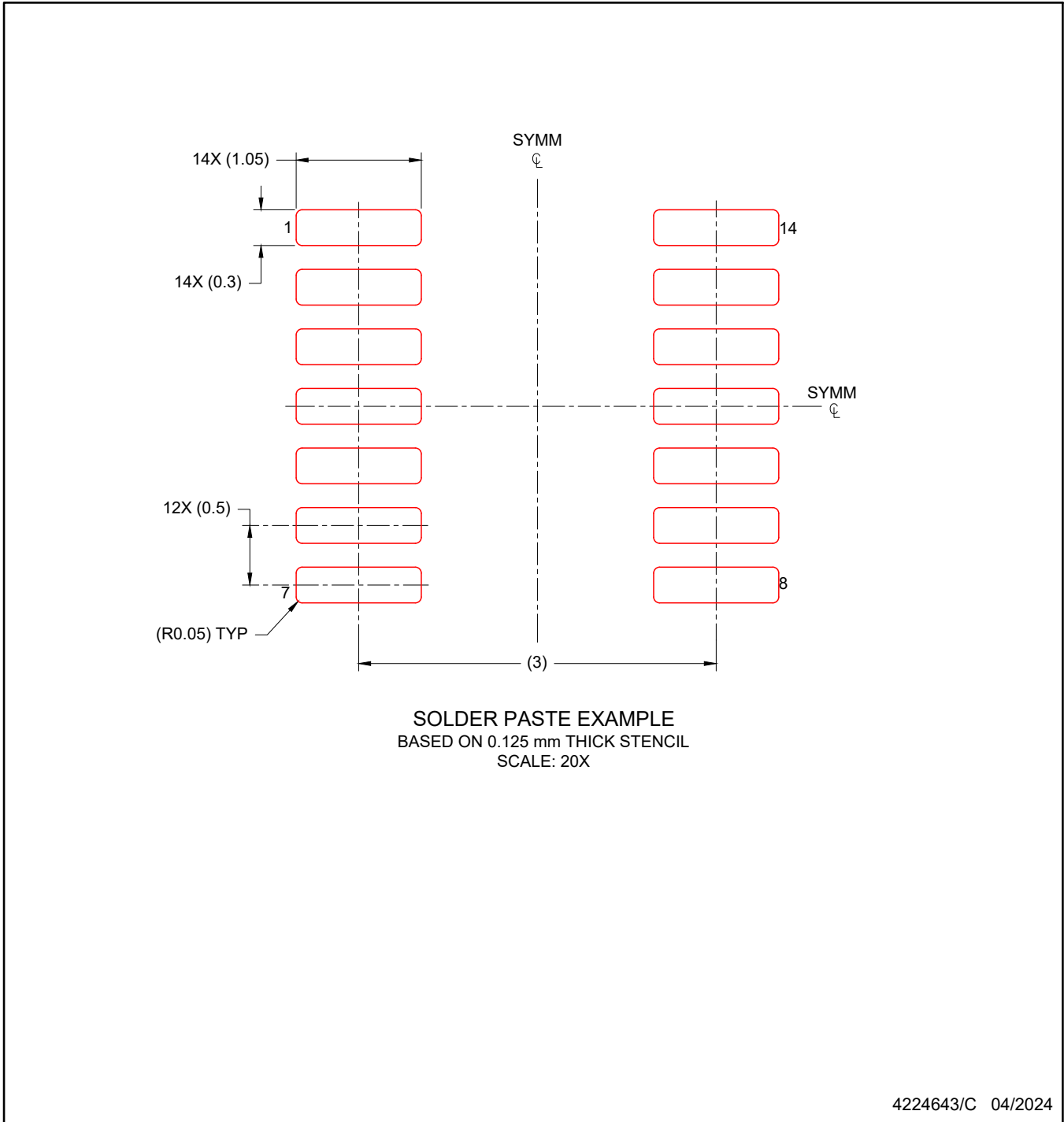

NOTES: (continued)

8. Laser cutting apertures with trapezoidal walls and rounded corners may offer better paste release. IPC-7525 may have alternate design recommendations.
9. Board assembly site may have different recommendations for stencil design.

## GENERIC PACKAGE VIEW

**DRR 12**

**WSON - 0.8 mm max height**

3 x 3, 0.5 mm pitch

PLASTIC SMALL OUTLINE - NO LEAD

This image is a representation of the package family, actual package may vary.  
Refer to the product data sheet for package details.

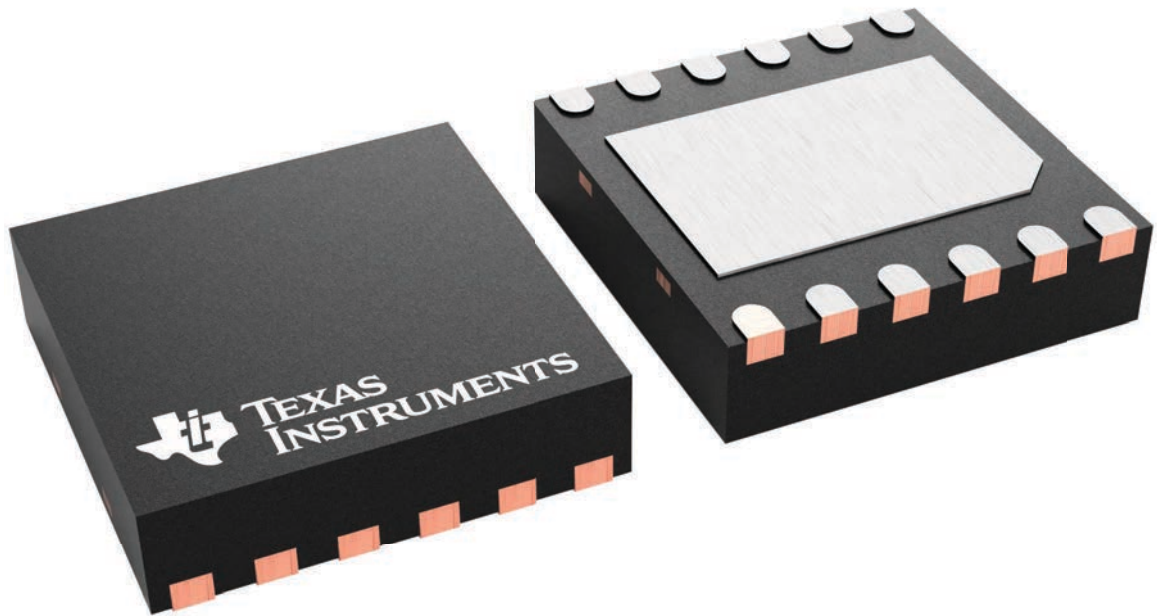

4223490/B

DRR0012C

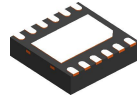

**PACKAGE OUTLINE**  
**WSO - 0.8 mm max height**

PLASTIC SMALL OUTLINE - NO LEAD

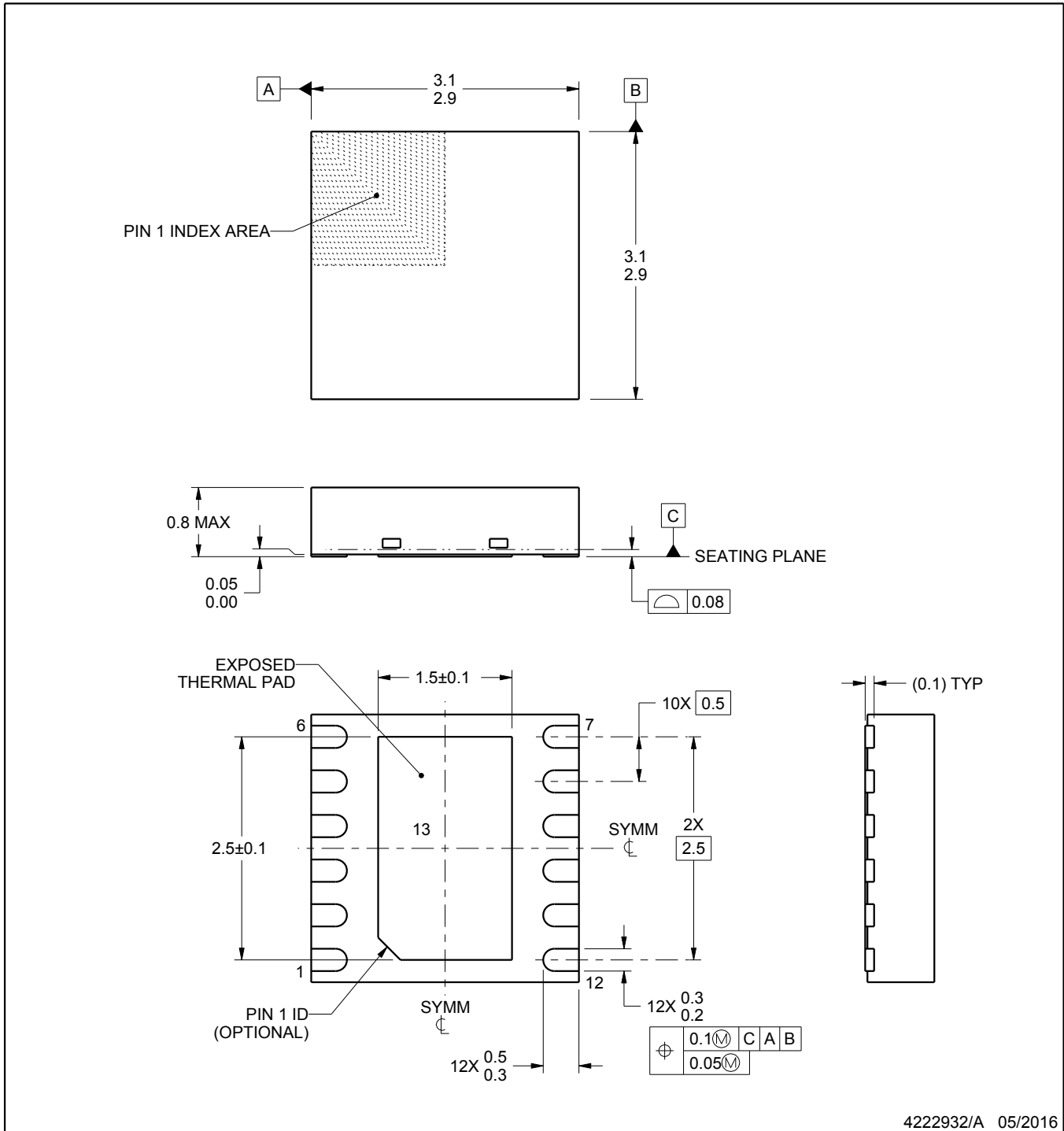

4222932/A 05/2016

NOTES:

1. All linear dimensions are in millimeters. Any dimensions in parenthesis are for reference only. Dimensioning and tolerancing per ASME Y14.5M.
2. This drawing is subject to change without notice.
3. The package thermal pad must be soldered to the printed circuit board for thermal and mechanical performance.

# EXAMPLE BOARD LAYOUT

DRR0012C

WSON - 0.8 mm max height

PLASTIC SMALL OUTLINE - NO LEAD

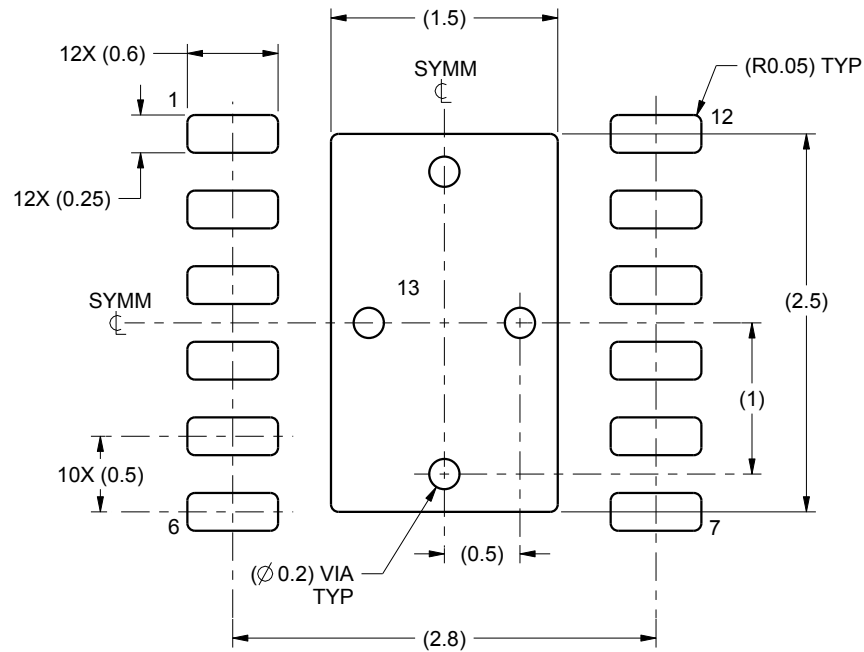

LAND PATTERN EXAMPLE  
SCALE:20X

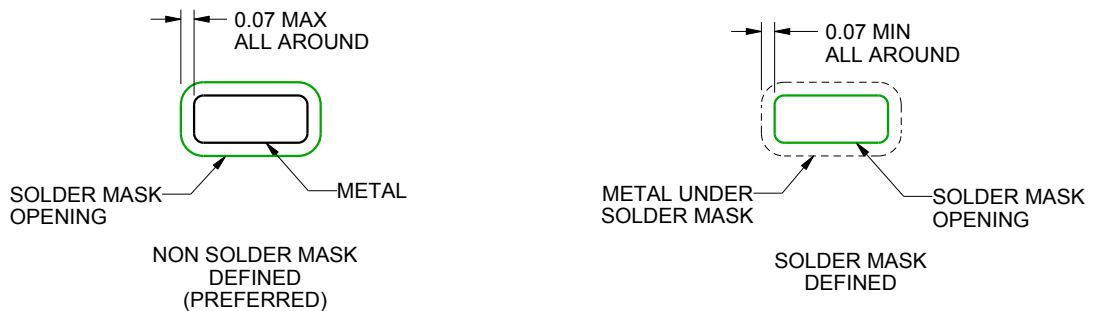

SOLDER MASK DETAILS

4222932/A 05/2016

NOTES: (continued)

4. This package is designed to be soldered to a thermal pad on the board. For more information, see Texas Instruments literature number SLUA271 ([www.ti.com/lit/slua271](http://www.ti.com/lit/slua271)).
5. Vias are optional depending on application, refer to device data sheet. If any vias are implemented, refer to their locations shown on this view. It is recommended that vias under paste be filled, plugged or tented.

# EXAMPLE STENCIL DESIGN

DRR0012C

WSON - 0.8 mm max height

PLASTIC SMALL OUTLINE - NO LEAD

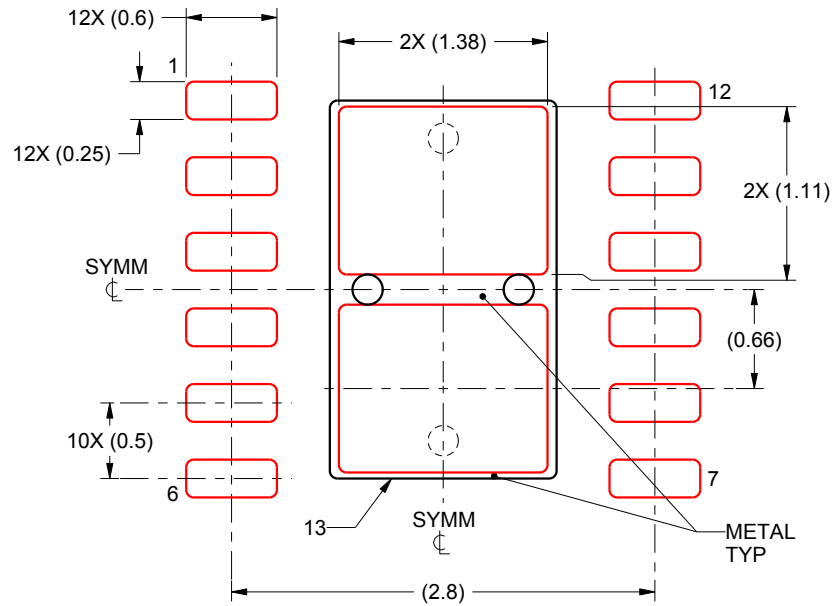

**SOLDER PASTE EXAMPLE**  
BASED ON 0.125 mm THICK STENCIL

EXPOSED PAD 13  
81.7% PRINTED SOLDER COVERAGE BY AREA  
SCALE:20X

4222932/A 05/2016

NOTES: (continued)

6. Laser cutting apertures with trapezoidal walls and rounded corners may offer better paste release. IPC-7525 may have alternate design recommendations.

## IMPORTANT NOTICE AND DISCLAIMER

TI PROVIDES TECHNICAL AND RELIABILITY DATA (INCLUDING DATA SHEETS), DESIGN RESOURCES (INCLUDING REFERENCE DESIGNS), APPLICATION OR OTHER DESIGN ADVICE, WEB TOOLS, SAFETY INFORMATION, AND OTHER RESOURCES "AS IS" AND WITH ALL FAULTS, AND DISCLAIMS ALL WARRANTIES, EXPRESS AND IMPLIED, INCLUDING WITHOUT LIMITATION ANY IMPLIED WARRANTIES OF MERCHANTABILITY, FITNESS FOR A PARTICULAR PURPOSE OR NON-INFRINGEMENT OF THIRD PARTY INTELLECTUAL PROPERTY RIGHTS.

These resources are intended for skilled developers designing with TI products. You are solely responsible for (1) selecting the appropriate TI products for your application, (2) designing, validating and testing your application, and (3) ensuring your application meets applicable standards, and any other safety, security, regulatory or other requirements.

These resources are subject to change without notice. TI grants you permission to use these resources only for development of an application that uses the TI products described in the resource. Other reproduction and display of these resources is prohibited. No license is granted to any other TI intellectual property right or to any third party intellectual property right. TI disclaims responsibility for, and you will fully indemnify TI and its representatives against, any claims, damages, costs, losses, and liabilities arising out of your use of these resources.

TI's products are provided subject to [TI's Terms of Sale](#) or other applicable terms available either on [ti.com](https://www.ti.com) or provided in conjunction with such TI products. TI's provision of these resources does not expand or otherwise alter TI's applicable warranties or warranty disclaimers for TI products.

TI objects to and rejects any additional or different terms you may have proposed.

Mailing Address: Texas Instruments, Post Office Box 655303, Dallas, Texas 75265  
Copyright © 2024, Texas Instruments Incorporated