TRIPLE 8/10-BIT, 165/110 MSPS, VIDEO AND GRAPHICS DIGITIZER WITH ANALOG PLL

FEATURES

- **Analog Channels**
 - -6 dB to 6 dB Analog Gain
 - Analog Input MUXs
 - Auto Video Clamp
 - Three Digitizing Channels, Each With Independently Controllable Clamp, PGA, and ADC
 - Clamping: Selectable Clamping Between Bottom Level and Mid-level
 - Offset: 1024-Step Programmable RGB or YPbPr Offset Control
 - PGA: 8-Bit Programmable Gain Amplifier
 - ADC: 8/10-Bit 165/110 MSPS A/D Converter
 - Automatic Level Control Circuit
 - Composite Sync: Integrated Sync-on-Green Extraction From GreenLuminance Channel
 - Support for DC and AC-Coupled Input Signals
- **PLL**
 - Fully Integrated Analog PLL for Pixel Clock Generation
 - 12-165 MHz Pixel Clock Generation From HSYNC Input
 - Adjustable PLL Loop Bandwidth for Minimum Jitter
 - 5-Bit Programmable Subpixel Accurate Positioning of Sampling Phase
- **Output Formatter**
 - Support for RGB/YCbCr 4:4:4 and YCbCr 4:2:2 Output Modes to Reduce Board Traces
 - Dedicated DATACLK Output for Easy Latching of Output Data
- **System**
 - Industry-Standard Normal/Fast I²C Interface With Register Readback Capability
 - Space-Saving TQFP-100 Pin Package
 - Thermally-Enhanced PowerPAD™ Package for Better Heat Dissipation

APPLICATIONS

- LCD TV/Monitors/Projectors
- DLP TV/Projectors
- PDP TV/Monitors
- PCTV Set-Top Boxes
- Digital Image Processing
- Video Capture/Video Editing
- Scan Rate/Image Resolution Converters
- Video Conferencing
- Video/Graphics Digitizing Equipment

DESCRIPTION

TVP7001 is a complete solution for digitizing video and graphic signals in RGB or YPbPr color spaces. The device supports pixel rates up to 165 MHz. Therefore, it can be used for PC graphics digitizing up to the VESA standard of UXGA (1600 × 1200) resolution at 60 Hz screen refresh rate, and in video environments for the digitizing of digital TV formats, including HDTV up to 1080p. TVP7001 can be used to digitize CVBS and S-video signal with 10-bit ADCs.

The TVP7001 is powered from 3.3-V and 1.8-V supply and integrates a triple high-performance A/D converter with clamping functions and variable gain, independently programmable for each channel. The clamping timing window is provided by an external pulse or can be generated internally. The TVP7001 includes analog slicing circuitry on the Y or G input to support sync-on-luminance or sync-on-green extraction. In addition, TVP7001 can extract discrete HSYNC and VSYNC from composite sync using a sync slicer.

TVP7001 also contains a complete analog PLL block to generate a pixel clock from the HSYNC input. Pixel clock output frequencies range from 12 MHz to 165 MHz.

All programming of the part is done via an industry-standard I²C interface, which supports both reading and writing of register settings. The TVP7001 is available in a space-saving TQFP 100-pin PowerPAD package.



Please be aware that an important notice concerning availability, standard warranty, and use in critical applications of Texas Instruments semiconductor products and disclaimers thereto appears at the end of this data sheet.

PowerPAD is a trademark of Texas Instruments.

ORDERING INFORMATION

T _A	PACKAGED DEVICES	PACKAGE OPTION
	100-PIN PLASTIC FLATPACK PowerPAD™	
0°C to 70°C	TVP7001PZP	Tray
	TVP7001PZPR	Reel

FUNCTIONAL BLOCK DIAGRAM

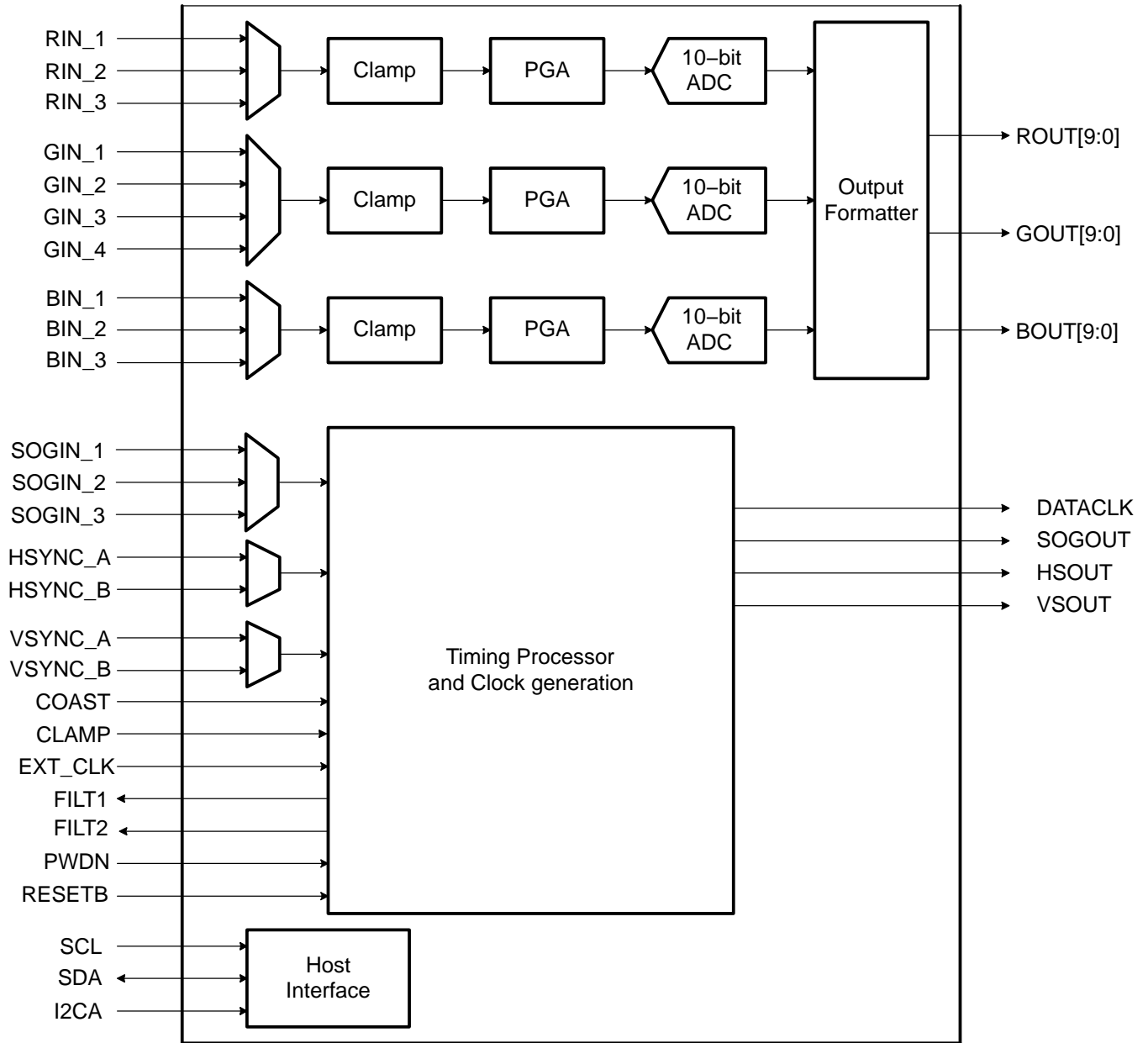

TERMINAL ASSIGNMENTS

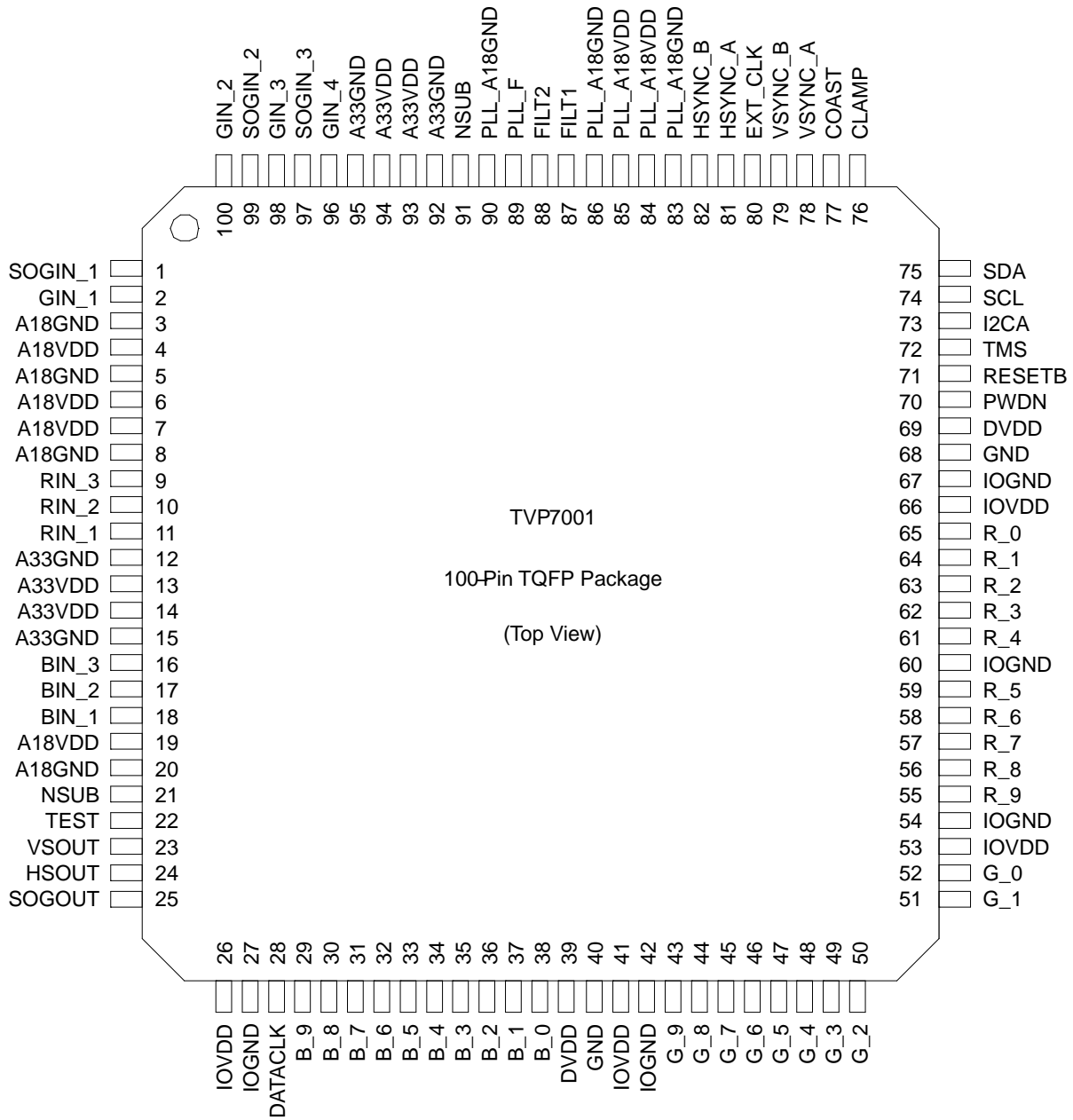

TERMINAL FUNCTIONS

TERMINAL		I/O	DESCRIPTION
NAME	NO.		
ANALOG VIDEO			
RIN_1	11	I	Analog video input for R/Pr 1
RIN_2	10	I	Analog video input for R/Pr 2
RIN_3	9	I	Analog video input for R/Pr 3
GIN_1	2	I	Analog video input for G/Y 1
GIN_2	100	I	Analog video input for G/Y 2
GIN_3	98	I	Analog video input for G/Y 3
GIN_4	96	I	Analog video input for G/Y 4
BIN_1	18	I	Analog video input for B/Pb 1
BIN_2	17	I	Analog video input for B/Pb 2
BIN_3	16	I	Analog video input for B/Pb 3
The inputs must be AC coupled. The recommended coupling capacitor is 0.1 μ F. Unused analog inputs should be connected to ground using a 10 nF capacitor.			
CLOCK SIGNALS			
DATACLK	28	O	Data clock output
EXT_CLK	80	I	External clock input for free running mode
TEST	22	O	Internal 5 MHz clock output, coast output, high-Z, or SOG output
DIGITAL VIDEO			
ROUT [9:0]	55–59, 61–65	O	Digital video output of R/Cr, ROUT [9] is MSB.
GOUT [9:0]	43-52	O	Digital video output of G/Y, GOUT [9] is MSB.
BOUT [9:0]	29-38	O	Digital video output of B/Cb, BOUT [9] is MSB. For a 4:2:2 mode BOUT outputs CbCr data. Unused outputs can be left unconnected.
MISCELLANEOUS SIGNALS			
PWDN	70	I	Power down input. 1: Power down 0: Normal mode
RESETB	71	I	Reset input, active low
TMS	72	I	Connect to ground
FILT1	87	O	External filter connection for PLL. The recommended capacitor is 0.1 μ F. see Figure 4
FILT2	88	O	External filter connection for PLL. The recommended capacitor is 4.7 nF. See Figure 4
HOST INTERFACE			
I ² C A	73	I	I ² C Address input
SCL	74	I	I ² C Clock input
SDA	75	I/O	I ² C Data bus
POWER SUPPLIES			
NSUB	21, 91	I	Substrate ground. Connect to analog ground.
A33VDD	13, 14, 93, 94	I	Analog power. Connect to 3.3 V.
A33GND	12, 15, 92, 95	I	Analog 3.3 V return. Connect to Ground.
A18GND	3, 5, 8, 20	I	Analog 1.8V return. Connect to Ground
A18VDD	4, 6, 7, 19	I	Analog power. Connect to 1.8 V.
PLL_A18VDD	84, 85	I	PLL analog power. Connect to 1.8 V.
PLL_F	89	I	PLL filter internal supply connection
PLL_A18GND	83, 86, 90	I	PLL analog power return. Connect to Ground.
GND	40, 68	I	Digital return. Connect to Ground.
DVDD	39, 69	I	Digital power. Connect to 1.8 V
IOGND	27, 42, 54, 60, 67	I	Digital power return. Connect to Ground.
IOVDD	26, 41, 53, 66	I	Digital power. Connect to 3.3 V or less for reduced noise.
SYNC SIGNALS			
CLAMP	76	I	External Clamp input. Unused inputs can be connected to ground.
COAST	77	I	External PLL COAST signal input. Unused inputs can be connected to ground

TERMINAL FUNCTIONS (continued)

TERMINAL		I/O	DESCRIPTION
NAME	NO.		
VSYNC_A	78	I	Vertical sync input A
VSYNC_B	79	I	Vertical sync input B. Unused inputs can be connected to ground.
HSYNC_A	81	I	Horizontal Sync input A
HSYNC_B	82	I	Horizontal Sync input B. Unused inputs can be connected to ground.
SOGIN1	1	I	Sync-on-green input 1
SOGIN2	99	I	Sync-on-green input 2
SOGIN3	97	I	Sync-on-green input 3. Unused inputs should be connected to ground using a 10 nF capacitor.
VSOUT	23	O	Vertical sync output
HSOUT	24	O	Horizontal sync output
SOGOUT	25	O	Sync-on-green slicer output

ABSOLUTE MAXIMUM RATINGS

over operating free-air temperature range (unless otherwise noted)⁽¹⁾

		UNIT
Supply voltage range	IOVDD to IOGND	–0.5 V to 4.5 V
	DVDD to GND	–0.5 V to 2.3 V
	PLL_A18VDD to PLL_A18GND and A18VDD to A18GND	–0.5 V to 2.3 V
	A33VDD to A33GND	–0.5 V to 4.5 V
Digital input voltage range	VI to GND	–0.5 V to 4.5 V
Analog input voltage range	AI to A33GND	–0.2 V to 2.3 V
Digital output voltage range	VO to GND	–0.5 V to 4.5 V
TA	Operating free-air temperature	0°C to 70°C
Tstg	Storage temperature	–65°C to 150°C

(1) Stresses beyond those listed under *absolute maximum ratings* may cause permanent damage to the device. These are stress ratings only and functional operation of the device at these or any other conditions beyond those indicated under *recommended operating conditions* is not implied. Exposure to absolute–maximum–rated conditions for extended periods may affect device reliability.

RECOMMENDED OPERATING CONDITIONS

over operating free-air temperature range, T_A = 0°C to 70°C (unless otherwise noted)

		MIN	NOM	MAX	UNIT
IOVDD	Digital I/O supply voltage	3.0	3.3	3.6	V
DVDD	Digital supply voltage	1.70	1.8	2.0	V
PLL_A18VDD	Analog PLL supply voltage	1.8	1.9	2.0	V
A18VDD	Analog supply voltage	1.8	1.9	2.0	V
A33VDD	Analog supply voltage	3.0	3.3	3.6	V
V _{I(P-P)}	Analog input voltage (ac–coupling necessary)	0.5		2.0	V
V _{IH}	Digital input voltage high	0.7 IOVDD			V
V _{IL}	Digital input voltage low			0.3 IOVDD	V
I _{OH}	High–level output current			2	mA
I _{OL}	Low–level output current			–2	mA
I _{OH_DATACLK}	DATACLK high–level output current			4	mA
I _{OL_DATACLK}	DATACLK low–level output current			–4	mA
T _A	Operating free–air temperature	0		70	°C

ELECTRICAL CHARACTERISTICSIOVDD = 3.3 V, DVDD = 1.8 V, PLL_A18VDD = 1.9 V, A18VDD = 1.9 V, A33VDD = 3.3 V, T_A = 25°C

PARAMETER		TEST CONDITIONS	MIN	TYP ⁽¹⁾	MAX ⁽²⁾	UNIT
POWER SUPPLY						
I _{A33VDD}	3.3-V supply current	78.75 MHz		60	60	mA
I _{IOVDD}	3.3-V supply current	78.75 MHz		32	78	mA
I _{A18VDD}	1.8-V supply current	78.75 MHz		225	225	mA
I _{PLL_18VDD}	1.8-V supply current	78.75 MHz		14	14	mA
I _{DVDD}	1.8-V supply current	78.75 MHz		7	9	mA
P _{TOT}	Total power dissipation, normal mode	78.75 MHz		746	901	mW
I _{A33VDD}	3.3-V supply current	162 MHz		95	95	mA
I _{IOVDD}	3.3-V supply current	162 MHz		44	125	mA
I _{A18VDD}	1.8-V supply current	162 MHz		230	230	mA
I _{PLL_18VDD}	1.8-V supply current	162 MHz		20	20	mA
I _{DVDD}	1.8-V supply current	162 MHz		17	20	mA
P _{TOT}	Total power dissipation, normal mode	162 MHz		936	1200	mW
P _{DOWN}	Total power dissipation, power-down mode			1		mW

(1) SMPTE color bar RGB input pattern used.

(2) Worst case vertical line RGB input pattern used.

ELECTRICAL CHARACTERISTICS

IOVDD = 3.3 V, DVDD = 1.8 V \pm 0.1, PLL_A18VDD = 1.9 V \pm 0.1, A18VDD = 1.9 V \pm 0.1, A33VDD = 3.3 V, T_A = 0°C to 70°C (unless otherwise noted)

PARAMETER		TEST CONDITIONS	MIN	TYP	MAX	UNIT
ANALOG INTERFACE						
	Input voltage range	By design	0.5	1.0	2.0	V _{pp}
Z _I	Input impedance, analog video inputs	By design	500			k Ω
DIGITAL LOGIC INTERFACE						
C _I	Input capacitance	By design	10			pF
Z _I	Input impedance	By design	500			k Ω
V _{OH}	Output voltage high	I _{OH} = 2 mA	0.8 IOVDD			V
V _{OL}	Output voltage low	I _{OL} = –2 mA	0.2 IOVDD			V
V _{OH_SCLK}	DATACLK output voltage high	I _{OH} = 4 mA	0.8 IOVDD			V
V _{OL_SCLK}	DATACLK output voltage low	I _{OH} = –2 mA	0.2 IOVDD			V
V _{IH}	High-level input voltage	By design	0.7 IOVDD			V
V _{IL}	Low-level input voltage	By design	0.3 IOVDD			V
A/D CONVERTERS						
	Conversion rate		12		165	MSPS
DNL	DC differential nonlinearity	10 bit, 110 MHz	–1	\pm 0.5	+1	LSB
		8 bit, 162 MHz	–1	\pm 0.5	+1	
INL	DC integral nonlinearity	10 bit, 110 MHz	–4	\pm 1	+4	LSB
		8 bit, 162 MHz	–4	\pm 1	+4	
	Missing code	8 bit, 162 MHz	none			
SNR	Signal-to-noise ratio	10 MHz, 1.0 V _{P-P} at 110 MSPS	52			dB
	Analog bandwidth	By design	500			MHz
PLL						
	Clock jitter		500			ps
	Phase adjustment		11.6			degree
	VCO frequency range		12		165	MHz

TIMING REQUIREMENTS

PARAMETER		TEST CONDITIONS ⁽¹⁾	MIN	TYP	MAX	UNIT
CLOCKS, VIDEO DATA, SYNC TIMING						
Duty cycle DATACLK			50%			
t_1	DATACLK rise time	10% to 90%		1		ns
t_2	DATACLK fall time	90% to 10%		1		ns
t_3	Output delay time		1.5		3.5	ns

(1) Measured with a load of 15 pF.

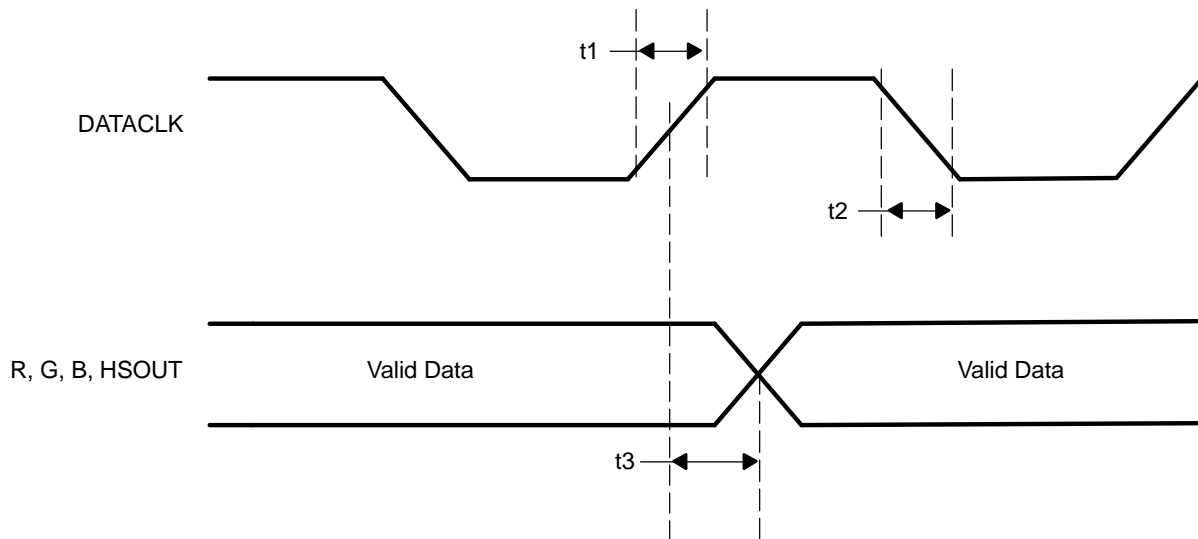

Figure 1. Clock, Video Data, and Sync Timing

TIMING REQUIREMENTS

PARAMETER		TEST CONDITIONS	MIN	TYP	MAX	UNIT
I²C HOST PORT TIMING						
t ₁	Bus free time between STOP and START	Specified by design	1.3			μs
t ₂	Setup time for a (repeated) START condition	Specified by design	0.6			μs
t ₃	Hold time (repeated) START condition	Specified by design	0.6			μs
t ₄	Setup time for a STOP condition	Specified by design	0.6			ns
t ₅	Data setup time	Specified by design	100			ns
t ₆	Data hold time	Specified by design	0	0.9		μs
t ₇	Rise time SDA and SCL signal	Specified by design		250		ns
t ₈	Fall time SDA and SCL signal	Specified by design		250		ns
C _b	Capacitive load for each bus line	Specified by design		400		pF
f _{12C}	I ² C clock frequency	Specified by design		400		kHz

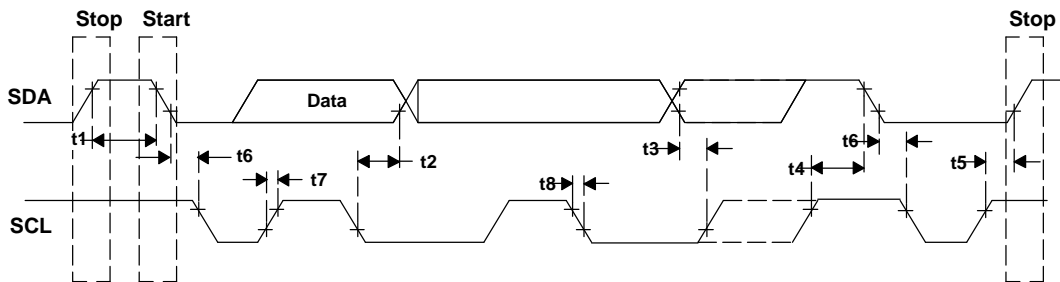

Figure 2. I²C Host Port Timing

FUNCTIONAL DESCRIPTION

Analog Channel

The TVP7001 contains three identical analog channels that are independently programmable. Each channel consists of a clamping circuit, a programmable gain amplifier, automatic offset control and an A/D converter.

Analog Input Switch Control

TVP7001 has 3 analog channels that accept up to 10 video inputs. The user can configure the internal analog video switches via the I²C interface. The 10 analog video inputs can be used for different input configurations some of which are:

- Up to 10 selectable individual composite video inputs
- Up to 2 selectable RGB graphics inputs
- Up to 3 selectable YPbPr video HD/SD inputs

The input selection is performed by the input select register at I²C subaddress 0x19 and 0x1A (see Input Mux Select 1 and Input Mux Select 2)

Analog Input Clamping

An internal clamping circuit restores the AC-coupled video/graphic signal to a fixed DC level. The clamping circuit provides line-by-line restoration of the signal black level to a fixed DC reference voltage. The selection between bottom and mid level clamping is performed by I²C subaddress 0x10 (see Sync On_Green Threshold). Fine clamps must also be enabled in the I²C register 2Ah for proper operation.

The internal clamping time can be adjusted by I²C clamp start and width registers at subaddress 0x05 and 0x06 (see Clamp Start and Clamp Width).

Programmable Gain Amplifier (PGA)

The TVP7001 PGA can scale a signal with a voltage-input compliance of 0.5-V_{pp} to 2-V_{pp} to a full-scale 10-bit A/D output code range. A 4-bit code sets the coarse gain (Red Coarse Gain, Green Coarse Gain, Blue Coarse Gain) with individual adjustment per channel. Minimum gain corresponds to a code 0x0 (2-V_{pp} full-scale input, –6 dB gain) while maximum gain corresponds to code 0xF (0.5-V_{pp} full-scale, +6 dB gain). TVP7001 also has 8-bit fine gain control (Red Fine Gain, Green Fine Gain, Blue Fine Gain) for RGB independently ranging from 1 to 2. For a normal PC graphics input, the fine gain will be used mostly.

Programmable Offset Control and Automatic Level Control (ALC)

The TVP7001 supports a programmable offset control for RGB independently. A 6-bit code sets the coarse offset (Red Coarse Offset, Green Coarse Offset, Blue Coarse Offset) with individual adjustment per channel. The coarse offset ranges from –32 LSB to +31 LSB. The coarse offset registers apply before the ADC. A 10-bit fine offset registers (Red Fine Offset, Green Fine Offset, Blue Fine Offset) apply after the ADC. The fine offset ranges from –512 LSB to +511 LSB.

ALC circuit maintains the level of the signal to be set at a value which is programmed at fine offset I²C register. It consists of pixel averaging filter and feedback loop. This ALC function can be enabled or disabled by I²C register address at 0x26. ALC circuit needs a timing pulse generated internally but user should program the position properly. The ALC pulse must be positioning after the clamp pulse. The position of ALC pulse is controlled by ALC placement I²C register at address 0x31. This is available only for internal ALC pulse timing. For external clamp, the timing control of clamp is not applicable so the ALC pulse control is also not applicable. Therefore it is suggested to keep the external clamp pulse as long as possible. ALC is applied as same position of external clamp pulse.

A/D Converters

All ADCs have a resolution of 10-bits and can operate up to 165 MSPS. All A/D channels receive an identical clock from the on-chip phase-locked loop (PLL) at a frequency between 12 MHz and 165 MHz. All ADC reference voltages are generated internally. Also the external sampling clock can be used.

Analog PLL

The analog PLL generates a high-frequency internal clock used by the ADC sampling and data clocking out to derive the pixel output frequency with programmable phase. The reference signal for this PLL is the horizontal sync signal supplied on the HSYNC input or from extracted horizontal sync of sync slicer block for embedded sync signals. The analog PLL consisted of phase detector, loop filter, voltage controlled oscillator (VCO), divider and phase select. The analog block diagram is shown at [Figure 3](#).

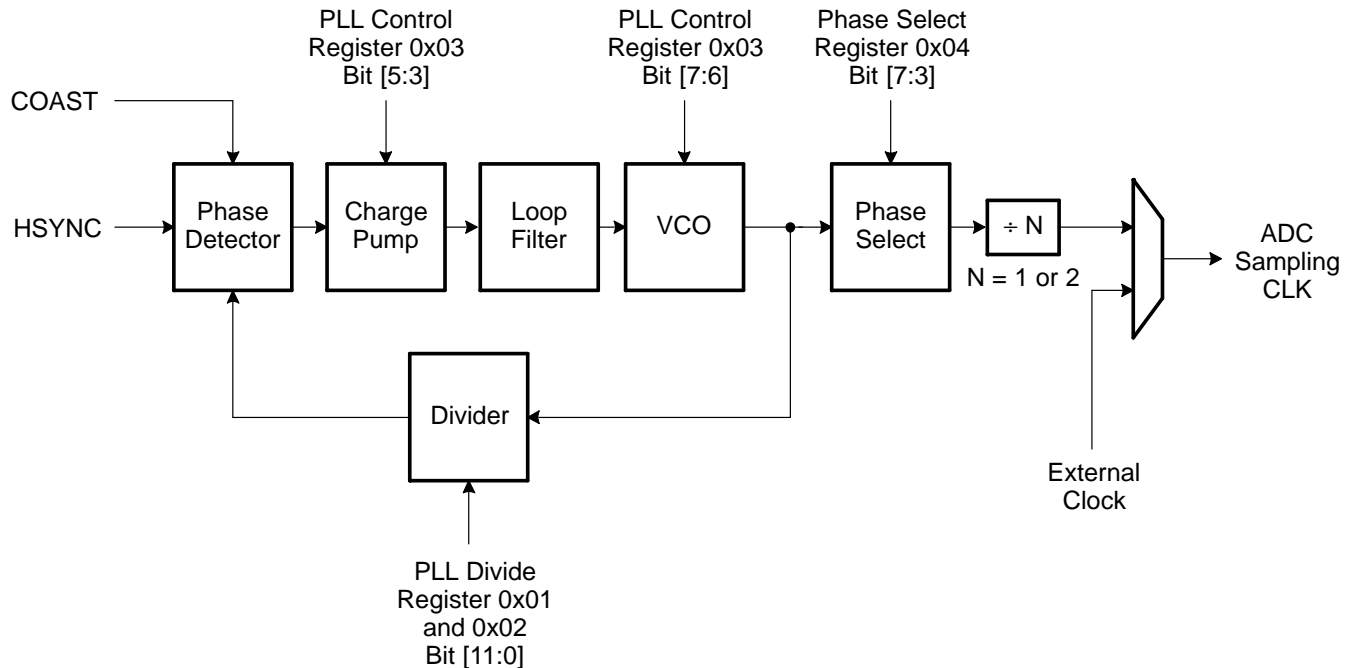

Figure 3. PLL Block Diagram

The COAST signal is used to allow the PLL to keep running at the same frequency, in the absence of the incoming HSYNC signal or disordered HSYNC period. This is useful during the vertical sync period, or any other time that the HSYNC is not available.

There are several PLL controls to produce the correct sampling clock. The 12-bit divider register is programmable to select exact multiplication number to generate the pixel clock in the range of 12 MHz to 165 MHz. The 3-bit loop filter current control register is to control the charge pump current that drives the low-pass loop filter. The applicable current values are listed in the [Table 1](#).

The 2-bit VCO range control is to improve the noise performance of the TVP7001. The frequency ranges for the VCO are shown in [Table 1](#). The phase of the PLL generated clock can be programmed in 32 uniform steps over a single clock period ($360/32=11.25$ degrees phase resolution) so that the sampling phase of the ADC can be accurately controlled.

In addition to sourcing the ADC channel clock from the PLL, an external pixel clock can be used (from pin 80). The PLL characteristics are determined by the loop filter design, by the PLL charge pump current, and by the VCO range setting. The loop filter design is shown in [Figure 4](#). Supported settings of VCO range and charge pump current for VESA standard display modes are listed in [Table 1](#).

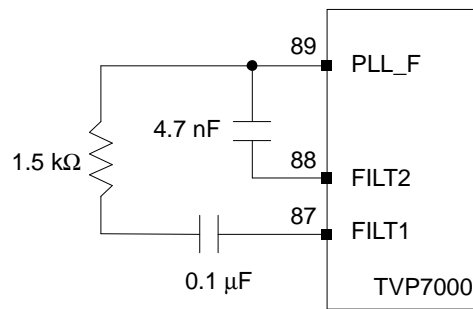

Figure 4. PLL Loop Filter

Table 1. Recommended VCO Range and Charge Pump Current Settings for Supporting Standard Display Formats

STANDARD	RESOL.	REFRESH RATE	HORIZ. FREQ. (kHz)	PIXEL RATE (MHz)	PLL Divider Total pix/line	PLLDIV [11:4] Reg 01h [7:0]	PLLDIV [3:0] Reg 02h [7:4]	Reg 03h	Output Divider Reg 04h [0]	VCO RANGE Reg 03h [7:6]	CP CURRENT Reg 03h [5:3]
VGA	640 × 480	60 Hz	31.5	25.175	1600(2×)	64h	00h	68h	1	Low (01b)	101b
		72 Hz	37.9	31.5	1664(2×)	68h	00h	58h	1	Low (01b)	011b
		75 Hz	37.5	31.5	1680(2×)	69h	00h	58h	1	Low (01b)	011b
		85 Hz	43.3	36	832	34h	00h	68h	0	Low (01b)	101b
SVGA	800 × 600	56 Hz	35.1	36	1024	40h	00h	68h	0	Low (01b)	101b
		60 Hz	37.9	40	1056	42h	00h	68h	0	Low (01b)	101b
		72 Hz	48.1	50	1040	41h	00h	68h	0	Low (01b)	101b
		75 Hz	46.9	49.5	1056	42h	00h	68h	0	Low (01b)	101b
		85 Hz	53.7	56.25	1048	41h	80h	68h	0	Low (01b)	101b
XGA	1024 × 768	60 Hz	48.4	65	1344	54h	00h	58h	0	Low (01b)	011b
		70 Hz	56.5	75	1328	53h	00h	A8h	0	Med (10b)	101b
		75 Hz	60	78.75	1312	52h	00h	A8h	0	Med (10b)	101b
		85 Hz	68.7	94.5	1376	56h	00h	A8h	0	Med (10b)	101b
SXGA	1280 × 1024	60 Hz	64	108	1688	69h	80h	A8h	0	Med (10b)	101b
		75 Hz	80	135	1688	69h	80h	98h	0	Med (10b)	011b
UXGA	1600 × 1200	60 Hz	75	162	2160	87h	00h	F8h	0	High (11b)	011b
Video	720 × 480p	60 Hz	31.468	27	1716(2×)	6Bh	40h	68h	1	Low (01b)	101b
	720 × 576p	50 Hz	31.25	27	1728(2×)	6Ch	00h	68h	1	Low (01b)	101b
	1280 × 720p	60 Hz	45	74.25	1650	67h	20h	A8h	0	Med (10b)	101b
	1280 × 720p	50 Hz	37.5	74.25	1980	7Bh	C0h	A8h	0	Med (10b)	101b
	1920 × 1080i	60 Hz	33.75	74.25	2200	89h	80h	A8h	0	Med (10b)	101b
	1920 × 1080i	50 Hz	28.125	74.25	2640	A5h	00h	A8h	0	Med (10b)	101b
	1920 × 1080p	60 Hz	67.5	148.5	2200	89h	80h	D8h	0	High (11b)	011b
	1920 × 1080p	50 Hz	56.25	148.5	2640	A5h	00h	D8h	0	High (11b)	011b

Sync Slicer

TVP7001 includes a circuit that compares the input signal on Green channel to a level 150mV (typical value) above the clamped level (sync tip). The slicing level is programmable by I²C register subaddress at 0x10. The digital output of the composite sync slicer is available on the SOGOUT pin.

Sync Separator

The sync separator automatically extracts VSYNC and HSYNC from the sliced composite sync input supplied at the SOG input. The G or Y input containing the composite sync must be AC coupled to the SOG input pin using a 10-nF capacitor. Support for PC graphics, SDTV, and HDTV up to 1080p is provided.

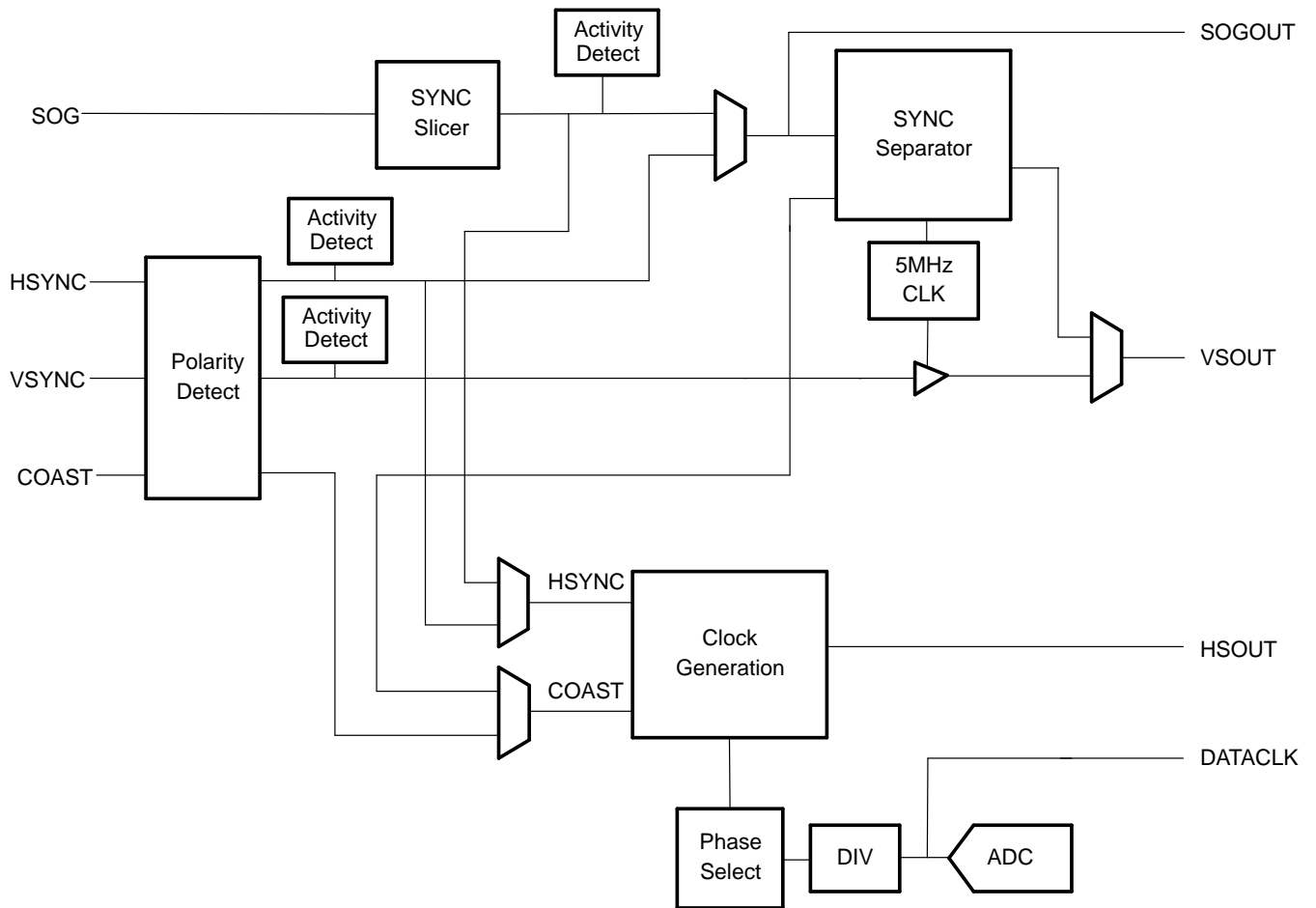
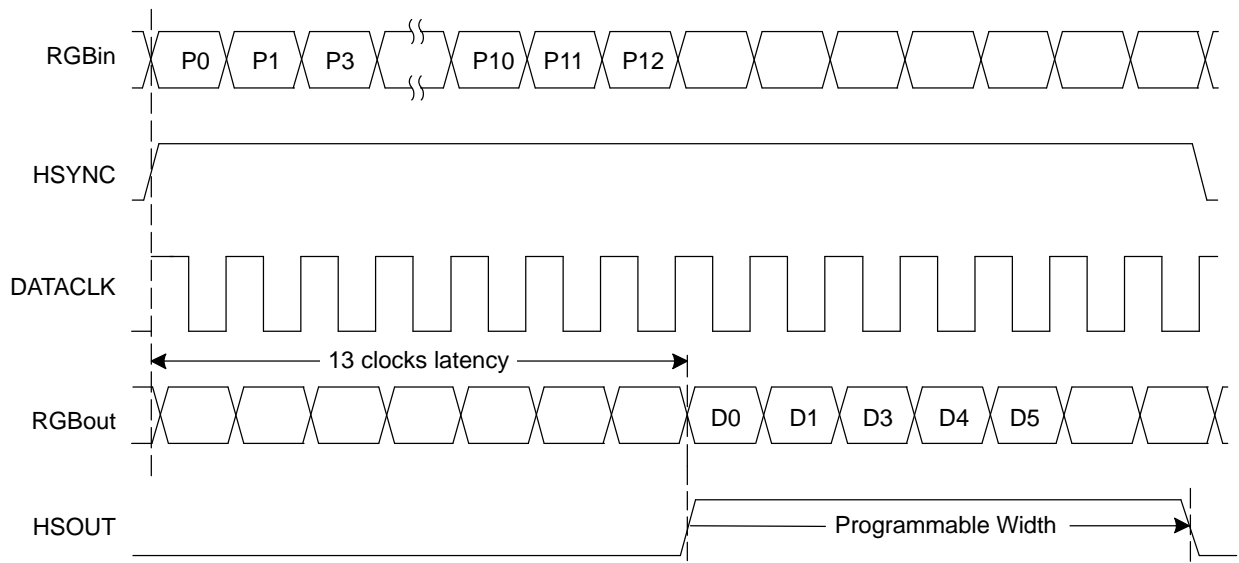

Figure 5. Sync Processing

Timing

The TVP7001 supports RGB/YCbCr 4:4:4 and YCbCr 4:2:2 modes. Output timing is shown in [Figure 6](#). All timing diagrams are shown for operation with internal PLL clock at phase 0. For a 4:2:2 mode, CbCr data outputs at BOUT[9:0] pins.



4:4:4: RGB/YCbCr Output Timing

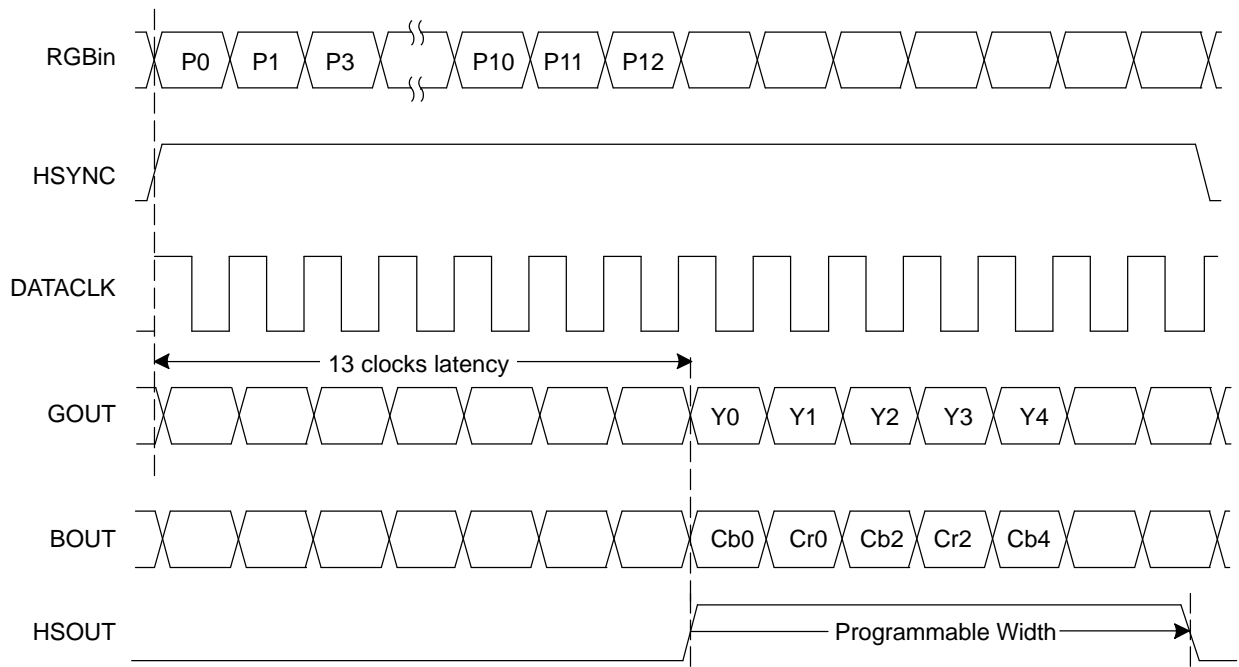

4:2:2 YCbCr Output Timing

Figure 6. Output Timing Diagram

I²C Host Interface

Communication with the TVP7001 device is via an I²C host interface. The I²C standard consists of two signals, serial input/output data (SDA) line and input clock line (SCL), which carry information between the devices connected to the bus. A third signal (I²CA) is used for slave address selection. Although an I²C system can be multi-mastered, the TVP7001 can function as a slave device only.

Since SDA and SCL are kept open-drain at logic high output level or when the bus is not driven, the user should connect SDA and SCL to a positive supply voltage via a pull up resistor on the board. SDA is implemented bi-directional. The slave addresses select, terminal 73 (I²CA), enables the use of two TVP7001 devices tied to the same I²C bus since it controls the least significant bit of the I²C device address

Table 2. I²C Host Interface Terminal Description

SIGNAL	TYPE	DESCRIPTION
I ² C A	I	Slave address selection
SCL	I	Input clock line
SDA	I/O	Input/output data line

Reset and I²C Bus Address Selection

TVP7001 can respond to two possible chip addresses. The address selection is made at reset by an externally supplied level on the I²C A pin. The TVP7001 device samples the level of terminal 73 at power-up or at the trailing edge of RESETB and configures the I²C bus address bit A0. The I²C A terminal has an internal pull-down resistor to pull the terminal low to set a zero.

Table 3. I²C Host Interface Device Addresses

A6	A5	A4	A3	A2	A1	A0 (I ² C A)	R/W	HEX
1	0	1	1	1	0	0 (default)	1/0	B9/B8
1	0	1	1	1	0	1 ⁽¹⁾	1/0	BB/BA

(1) If terminal 73 strapped to DVDD via a 2.2 kΩ resistor, I²C device address A0 is set to 1.

I²C Operation

Data transfers occur utilizing the following illustrated formats.

S	10111000	ACK	subaddress	ACK	send data	ACK	P
---	----------	-----	------------	-----	-----------	-----	---

Read from I²C control registers

S	10111000	ACK	subaddress	ACK	S	10111001	ACK	receive data	NAK	P
---	----------	-----	------------	-----	---	----------	-----	--------------	-----	---

S = I²C Bus Start condition

P = I²C Bus Stop condition

ACK = Acknowledge generated by the slave

NAK = Acknowledge generated by the master, for multiple byte read master with ACK each byte except last byte

Subaddress = Subaddress byte

Data = Data byte, if more than one byte of DATA is transmitted (read and write), the subaddress pointer is automatically incremented

I²C bus address = Example shown that I²C A is in default mode. Write (B8h), Read (B9h)

Power-up, Reset, and Initialization

No specific power-up sequence is required, but all power supplies should be active and stable within 500 ms of each other. Reset may be low during power-up, but must remain low for at least 1 μs after the power supplies become stable. Alternately reset may be asserted any time with minimum 5 ms delay after power-up and must remain asserted for at least 1 μs. Reset timing is shown in Figure 7. It is also recommended that any I²C operation starts 1 μs after reset ended. Table 4 describes the status of the TVP7001 terminals during and immediately after reset.

Table 4. Reset Sequence

SIGNAL NAME	DURING RESET	RESET COMPLETED
ROUT[9:0], BOUT[9:0], BOUT[9:0]	High impedance	Output
HSOUT, VSOUT, SOGOUT	High impedance	Output
DATACLK	High impedance	Output

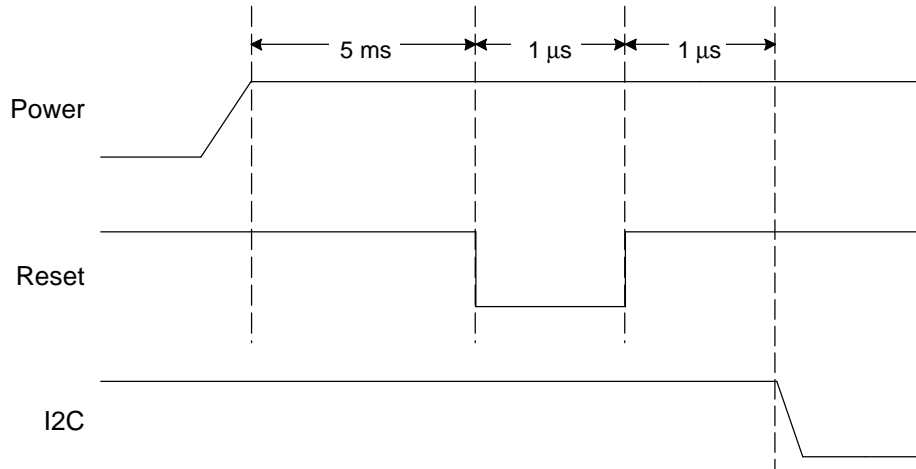

Figure 7. Reset Timing

Control Registers

The TVP7001 is initialized and controlled by a set of internal registers that define the operating parameters of the entire device. Communication between the external controller and the TVP7001 is through a standard I²C host port interface, as described earlier.

Table 5 shows the summary of these registers. Detailed programming information for each register is described in the following sections.

Table 5. Control Registers Summary⁽¹⁾⁽²⁾

Register Name	I ² C Subaddress	Default	R/W
Chip Revision	00h	00h	R
PLL Divide MSB	01h	69h	R/W
PLL Divide LSB	02h	D0h	R/W
PLL Control	03h	48h	R/W
Phase Select	04h	80h	R/W
Clamp Start	05h	80h	R/W
Clamp Width	06h	80h	R/W
HSYNC Output Width	07h	20h	R/W
Blue Fine Gain	08h	80h	R/W
Green Fine Gain	09h	80h	R/W
Red Fine Gain	0Ah	80h	R/W
Blue Fine Offset	0Bh	80h	R/W
Green Fine Offset	0Ch	80h	R/W
Red Fine Offset	0Dh	80h	R/W
Sync Control 1	0Eh	40h	R/W
PLL and Clamp Control	0Fh	4Eh	R/W

(1) Register addresses not shown in the register map summary are reserved and must not be written to.

(2) Writing to or reading from any value labeled “Reserved” register may cause erroneous operation of the TVP7001. For registers with reserved bits, a 0b must be written to reserved bit locations unless otherwise stated.

Table 5. Control Registers Summary (continued)

Register Name	I ² C Subaddress	Default	R/W
Sync On Green Threshold	10h	B8h	R/W
Sync Separator Threshold	11h	20h	R/W
Pre-Coast	12h	00h	R/W
Post-Coast	13h	00h	R/W
Sync Detect Status	14h		R
Output Formatter	15h	00h	R/W
Test Register	16h	00h	R/W
Reserved	17h–18h		
Input Mux Select 1	19h	00h	R/W
Input Mux Select 2	1Ah	00h	R/W
Blue and Green Coarse Gain	1Bh	55h	R/W
Red Coarse Gain	1Ch	05h	R/W
Fine Offset LSB	1Dh	00h	R/W
Blue Coarse Offset	1Eh	20h	R/W
Green Coarse Offset	1Fh	20h	R/W
Red Coarse Offset	20h	20h	R/W
HSOUT Output Start	21h	09h	R/W
MISC Control	22h	00h	R/W
Reserved	23h–25h		
Automatic Level Control Enable	26h	00h	R/W
Reserved	27h		
Automatic Level Control Filter	28h	00h	R/W
Reserved	29h		
Fine Clamp Control	2Ah	00h	R/W
Power Control	2Bh	00h	R/W
ADC Setup	2Ch	00h	R/W
Coarse Clamp Control 1	2Dh	00h	R/W
SOG Clamp	2Eh	00h	R/W
Reserved	2Fh–30h		
ALC Placement	31h	00h	R/W
R = Read only W = Write only R/W = Read Write			

Register Definitions

Chip Revision

Subaddress 00h

Read Only

7	6	5	4	3	2	1	0
Chip revision [7:0]							

Chip revision [7:0]: Chip revision number

PLL Divide**Subaddress** 01h–02h

Default (69D0h)

7	6	5	4	3	2	1	0
PLL divide MSB [11:4]							
PLL divide LSB [3:0]				Reserved			

PLL divide [11:0]: PLL divide number sets the number of pixels per line. Controls the PLL feedback divider. MSB [11:4] bits should be loaded first whenever a change is required

PLL Control**Subaddress** 03h

Default (48h)

7	6	5	4	3	2	1	0
VCO[1:0]		Charge Pump Current [2:0]			Reserved	Reserved	Reserved

VCO [1:0]: Selects VCO frequency range

00 = Ultra low, less than 20 MHz

01 = Low (default), 20 MHz to 69 MHz

10 = Medium, 70 MHz to 135 MHz

11 = High, 136 MHz to 165 MHz

Charge Pump Current [2:0]: Selects charge current of PLL LPF

000 = Small (default)

111 = Large

Phase Select**Subaddress** 04h

Default (80h)

7	6	5	4	3	2	1	0
Phase Select [4:0]					Reserved		DIV2

Phase Select [4:0]: ADC Sampling clock phase select. (1 LSB = $360/32 = 11.25^\circ$)

DATACLK Divide-by-2

0 = DATACLK/1

1 = DATACLK/2

Clamp Start**Subaddress** 05h

Default (80h)

7	6	5	4	3	2	1	0
Clamp Start [7:0]							

Clamp Start [7:0]: Positions the clamp signal an integer number of clock periods after the HSYNC signal. If external clamping is selected this value has no meaning. Clamp Start must be correctly positioned for proper operation. See [Table 6](#) for the recommended settings.

Clamp Width**Subaddress** 06h

Default (80h)

7	6	5	4	3	2	1	0
Clamp Width [7:0]							

Clamp Width [7:0]: Sets the width in pixels for clamp. See register Clamp Start.

Table 6. Recommended Fine Clamp Settings

VIDEO STANDARD	CLAMP START	CLAMP WIDTH
HDTV (tri-level)	50 (32h)	32 (20h)
SDTV (bi-level)	6 (06h)	16 (10h)
PC Graphics	6 (06h)	16 (10h)

HSYNC Output Width

Subaddress 07h Default (20h)

7	6	5	4	3	2	1	0
HSOUT Width [7:0]							

HSOUT Width [7:0]: Sets the width in pixels for HSYNC output.

Blue Fine Gain

Subaddress 08h Default (80h)

7	6	5	4	3	2	1	0
Blue Gain [7:0]							

Blue Gain [7:0]: PGA digital gain (contrast) for Blue channel applied after the ADC. Fine Gain = 1 + Blue Gain[7:0]/256

Blue Fine Gain	Fine Gain
00h	1.0
80h	1.5 (default)
FFh	2.0

Green Fine Gain

Subaddress 09h Default (80h)

7	6	5	4	3	2	1	0
Green Gain [7:0]							

Green Gain [7:0]: PGA digital gain (contrast) for Green channel applied after the ADC. Fine Gain = 1 + Green Gain[7:0]/256
80h = 1.5 (default)

Red Fine Gain

Subaddress 0Ah Default (80h)

7	6	5	4	3	2	1	0
Red Gain [7:0]							

Red Gain [7:0]: Sets PGA digital gain (contrast) for Red channel applied after the ADC. Fine Gain = 1 + Red Gain[7:0]/256
80h = 1.5 (default).

Blue Fine Offset

Subaddress 0Bh Default (80h)

7	6	5	4	3	2	1	0
Blue Offset [9:2]							

Blue Offset [9:2]: DC digital offset (brightness) for Blue channel applied after the ADC. The default setting of 80h will place the bottom-level (YRGB) clamped output blank levels at 0 and mid-level clamped (PbPr) output blank levels at 512.

Blue Offset	Description
11111111	maximum
10000001	1 LSB
10000000	0 (default)
01111111	-1 LSB
00000000	minimum

Green Fine Offset

Subaddress 0Ch Default (80h)

7	6	5	4	3	2	1	0
Green Offset [9:2]							

Green Offset [9:2]: DC digital offset (brightness) for Green channel applied after the ADC. See Red Fine Offset register at I²C address 0x0B

Red Fine Offset

Subaddress 0Dh Default (80h)

7	6	5	4	3	2	1	0
Red Offset [9:2]							

Red Offset [9:2]: DC digital offset (brightness) for Red channel applied after the ADC. See Blue Fine Offset register at I²C address 0x0B.

Sync Control 1

Subaddress 0Eh

Default (40h)

7	6	5	4	3	2	1	0
HSPO	HSIP	HSOP	AHSO	AHSS	VSOI	AVSO	AVS

HSPO: HSYNC Polarity Override

0 = Polarity determined by chip (default)

1 = Polarity set by Bit 6 in register 0Eh

HSIP: HSYNC Input Polarity

0 = Indicates input HSYNC polarity active low

1 = Indicates input HSYNC polarity active high (default)

HSOP: HSYNC Output Polarity

0 = Active low (default)

1 = Active high

AHSO: Active HSYNC Override

0 = The active interface is selected via Bit 6 in register 14h, selected by chip (default)

1 = The user can select HSYNC to be used via Bit 3

AHSS: Active HSYNC Select. The indicated HSYNC will be used only if Bit 4 is set to 1 or both syncs are active (Bits 1,7 =1 in 14h)

0 = Select HSYNC as the active sync (default)

1 = Select Sync-on-green as the active sync

VSOI: VSYNC Output Invert (relative to VSYNC IN polarity)

0 = No invert (default)

1 = Invert

AVSO: Active VSYNC Override

0 = The active interface is selected via Bit3 in register 14h, selected by chip (default)

1 = The user can select the VSYNC to be used via Bit 0

AVS: Active VSYNC select, This bit is effective when AVSO Bit 1 is set to 1.

0 = Raw VSYNC (default)

1 = Sync separated VSYNC

PLL and Clamp Control

Subaddress 0Fh

Default (4Eh)

7	6	5	4	3	2	1	0
CF	CP	Coast Sel	CPO	CPC	Reserved	FCPD	Free run

Clamp Function:

0 = Internal Clamp(default)

1 = External Clamp

Clamp Polarity:

0 = Active high

1 = Active low (default)

Coast Select:

0 = External coast (default)

1 = Internal Coast

Coast Polarity Override:

0 = Polarity determined by chip (default)

1 = Polarity set be Bit 3 in register 0Fh

Coast Polarity Change:

0 = Active low

1 = Active high (default)

Full Chip Power-Down:

0 = Power-down mode

1 = Normal operation (default)

Free run: Also ADC test mode, ADC uses external clock

0 = PLL normal operation (default)

1 = Enabled

Sync On_Green Threshold

Subaddress 10h

Default (B8h)

7	6	5	4	3	2	1	0
SOG Threshold [4:0]					Blue CS	Green CS	Red CS

SOG Threshold [4:0]: Sets the voltage level of the SOG slicer comparator. The minimum setting is 0 mV and the maximum is 350 mV. The step is 11.2 mV. (default 17h, 10h recommended)

Blue Clamp Select: When free running mode this bit is no effect

0 = Bottom level clamp (default)

1 = Mid level clamp

Green Clamp Select: When free running mode this bit is no effect

0 = Bottom level clamp (default)

1 = Mid level clamp

Red Clamp Select: When free running mode this bit is no effect.

0 = Bottom level clamp (default)

1 = Mid level clamp

NOTE:

Bottom level clamping is required for Y and RGB inputs, while mid level clamping is required for Pb and Pr inputs. The internal clamp pulse must also be correctly positioned for proper clamp operation. See register 05h.

Sync Separator Threshold

Subaddress 11h

Default (20h)

7	6	5	4	3	2	1	0
Sync Separator Threshold [7:0]							

Sync Separator Threshold [7:0]: Sets how many internal 5 MHz clock periods the sync separator will count to before toggling high or low.

SyncSeparator Threshold [7:0] x 133 ns must be greater than the width of the negative sync pulse. This setting can also affect the position of VSOUT. See register 22h.

Pre-Coast

Subaddress 12h

Default (00h)

7	6	5	4	3	2	1	0
Pre-Coast [7:0]							

Pre-Coast [7:0]: Sets the number of HSYNC periods that coast becomes active prior to VSYNC.

Post-Coast

Subaddress 13h

Default (00h)

7	6	5	4	3	2	1	0
Post-Coast [7:0]							

Post-Coast [7:0]: Sets the number of HSYNC periods that coast stays active following VSYNC. Post-Coast settings must be extended to include Macrovision pseudo syncs when Macrovision is present.

Table 7. Recommended Pre and Post-Coast Settings

STANDARD	PRE_COAST	POST-COAST
480i/p with Macrovision	3	0Ch
576i/p with Macrovision	3	0Ch
1080i	0	0
1080p	0	0
720p	0	0

Sync Detect Status

Subaddress 14h

Read Only

7	6	5	4	3	2	1	0
HSD	AHS	IHSPD	VSD	AVS	VSPD	SOGD	ICPD

HSYNC Detect:

- 0 = No HSYNC detected
- 1 = HSYNC detected

Active HSYNC:

- 0 = HSYNC input pin
- 1 = HSYNC from SOG

Input HSYNC Polarity Detect:

- 0 = Active low
- 1 = Active high

VSYNC Detect:

- 0 = No VSYNC detected
- 1 = VSYNC detected

AVS:

- 0 = VSYNC input pin
- 1 = VSYNC from Sync separator

VSYNC Polarity Detect:

- 0 = Active low
- 1 = Active high

SOG Detect:

- 0 = No SOG detected
- 1 = SOG is present on the SOG interface

Input Coast Polarity Detect:

- 0 = Active low
- 1 = Active high

Output Formatter

Subaddress 15h

Default (00h)

7	6	5	4	3	2	1	0
Reserved				Clamp REF	CbCr order	422/444	Reserved

Clamp REF:

- 0 = Clamp pulse placement respect to the trailing edge of HSYNC (default)
- 1 = Clamp pulse placement respect to the leading edge of HSYNC

CbCr order: This bit is effective when Bit 1 is set to 1.

- 0 = CrCb (default)
- 1 = CbCr

422/444:

- 0 = Output is in 4:4:4 format (default)
- 1 = Output is in 4:2:2 format

Test Register

Subaddress 16h

Default (00h)

7	6	5	4	3	2	1	0
Pixel tolerance [2:0]			Reserved	Test output		PLL PD	STRTB

Pixel tolerance: Controls sensitivity to HSYNC input stability. Increasing the pixel tolerance may be required for input signals having horizontal instability.

- 000 = No tolerance (default)
- 001 = 1 pixel tolerance (recommended setting for nominal input)
- 111 = 7 pixel tolerance (maximum)

Test output: Controls TEST 1 pin output

- 00 = 5 MHz clock (default)
- 01 = Coast output
- 10 = Clamp
- 11 = High impedance

PLL PD: PLL power-down

- 0 = Normal operation (default)
- 1 = PLL powered down

STRTB: PLL start-up circuit enable

- 0 = Disabled (default)
- 1 = Enabled

Input Mux Select 1

Subaddress 19h

Default (00h)

7	6	5	4	3	2	1	0
SOG Select [1:0]		Red Select [1:0]		Green Select [1:0]		Blue Select [1:0]	

SOG Select [1:0]:

- 00 = CH1 selected (default)
- 01 = CH2 selected
- 10 = CH3 selected
- 11 = Reserved

Red Select [1:0]:

- 00 = CH1 selected (default)
- 01 = CH2 selected
- 10 = CH3 selected
- 11 = Reserved

Green Select [1:0]:

- 00 = CH1 selected (default)
- 01 = CH2 selected
- 10 = CH3 selected
- 11 = CH4 selected

Blue Select [1:0]:

- 00 = CH1 selected (default)
- 01 = CH2 selected
- 10 = CH3 selected
- 11 = Reserved

Input Mux Select 2

Subaddress 1Ah

Default (00h)

7	6	5	4	3	2	1	0
1	Reserved			VSYNC Select		Reserved	HSYNC Select

Bit 7: It must be written to 1.

VSYNC Select:

- 0 = VSYNC_A selected (default)
- 1 = VSYNC_B selected

HSYNC Select [1:0]:

- 0 = HSYNC_A selected (default)
- 1 = HSYNC_B selected

Blue and Green Coarse Gain

Subaddress 1Bh

Default (55h)

7	6	5	4	3	2	1	0
Green Gain [3:0]				Blue Gain [3:0]			

Green Coarse Gain [3:0]: Coarse analog gain for Green channel applied before the ADC. To avoid clipping at the ADC, Vp-p in X Gain must be less than 1 Vp-p.

Gain [3:0] Description

0000 = 0.5

0001 = 0.6

0010 = 0.7

0011 = 0.8

0100 = 0.9

0101 = 1.0

0110 = 1.1

0111 = 1.2

1000 = 1.3

Maximum recommended gain for 700mVp-p input.

1001 = 1.4

1010 = 1.5

1011 = 1.6

1100 = 1.7

1101 = 1.8

1110 = 1.9

1111 = 2.0

Blue Coarse Gain [3:0]: Coarse gain for Blue channel

Red Coarse Gain

Subaddress 1Ch

Default (05h)

7	6	5	4	3	2	1	0
Reserved				Red Gain [3:0]			

Red Coarse Gain [3:0]: Coarse analog gain for Red channel applied before the ADC.

Fine Offset LSB

Subaddress 1Dh

Default (00h)

7	6	5	4	3	2	1	0
Reserved		Red Offset [1:0]		Green Offset [1:0]		Blue Offset [1:0]	

Red Offset [1:0] : Offset LSB for red channel. This is LSB of register 0x0D

Green Offset [1:0] : Offset LSB for green channel. This is LSB of register 0x0C

Blue Offset [1:0] : Offset LSB for blue channel. This is LSB of register 0x0B

Blue Coarse Offset

Subaddress 1Eh

Default (20h)

7	6	5	4	3	2	1	0
Reserved		Blue offset [5:0]					

Blue Coarse offset [5:0]: Coarse analog offset for blue channel applied before the ADC.

1Fh = +124 LSB (Recommended for optimum ALC performance)

01h = 4 LSB

00h = 0 LSB

20h = -4 LSB (default)

3Fh = -128 LSB

Green Coarse Offset

Subaddress 1Fh Default (20h)

7	6	5	4	3	2	1	0
Reserved		Coarse Green offset [5:0]					

Green Coarse offset [5:0]: Coarse analog offset for green channel applied before the ADC.
 1Fh = +124 LSB (Recommended for optimum ALC performance)

Red Coarse Offset

Subaddress 20h Default (20h)

7	6	5	4	3	2	1	0
Reserved		Coarse Red offset [5:0]					

Red Coarse offset [5:0]: Coarse analog offset for blue channel applied before the ADC.
 1Fh = +124 LSB (Recommended for optimum ALC performance)

HSOUT Output Start

Subaddress 21h Default (09h)

7	6	5	4	3	2	1	0
HSOUT Start [7:0]							

HSOUT Start [7:0]: HSYNC output Start pixel number.

MISC Control

Subaddress 22h Default (00h)

7	6	5	4	3	2	1	0
Reserved				MAC_EN	Reserved	VS_ALIGN	Reserved

MAC_EN:

- 0 = Macrovision compatibility disabled (default)
- 1 = Macrovision compatibility enabled

The MAC_EN bit can be left set to logic 0 for video formats that do not have Macrovision pseudosyncs present.

When switching to video formats with Macrovision present, the MAC_EN bit must be set to logic 0 for 3 ms before setting it to logic 1.

VS_ALIGN

- 0 = VSOUT is derived from both the sync separator and the internal pixel/line counters.
- 1 = VSOUT is derived directly from the sync separator. VSOUT delay will vary with sync separator threshold (Reg 11h). This setting is recommended for most applications.

Automatic Level Control Enable

Subaddress 26h Default (00h)

7	6	5	4	3	2	1	0
ALC enable	Reserved						

ALC enable: Automatic level control enable

- 0 = Disabled (default)
- 1 = Enabled

Automatic Level Control Filter

Subaddress 28h

Default (00h)

7	6	5	4	3	2	1	0
Reserved	NSV[3:0]				NSH [2:0]		

The horizontal ALC coefficient (NSH) specifies the number of the horizontal samples (N) used to calculate the average blank level per horizontal line. Offset error correction is applied immediately based on the vertical (NSV) coefficient.

The vertical coefficient (NSV) specifies the amount of offset error correction (derived from NSH) that is applied to each line update.

NSV [3:0]: ALC vertical filter coefficient

NSV [3:0]	Description
0000 =	1 (default) Maximum error correction applied per line update
0001 =	½
0010 =	1/4
0011 =	1/8
0100 =	1/16
0101 =	1/32
0110 =	1/64
0111 =	1/128
1000 =	½56
1001 =	1/512
1010 =	1/1024 Minimum error correction applied per line update
1011 =	1/1024
1100 =	1/1024
1101 =	1/1024
1110 =	1/1024
1111 =	1/1024

NSH [2:0]: ALC horizontal sample filter coefficient

NSH [2:0]	Description
000 =	1/2 (default) Minimum number of pixels (2) used in horizontal filter
001 =	1/4
010 =	1/8
011 =	1/16
100 =	1/32
101 =	1/64
110 =	1/128
111 =	1/256 Maximum number of pixels (256) used in horizontal filter

Fine Clamp Control

Subaddress 2Ah

Default (00h)

7	6	5	4	3	2	1	0
Reserved			Fine swsel[1:0]		Fine B	Fine G	Fine R

Fine swsel: Fine clamp time constant adjustment

00 = Highest (default), Recommended setting

01 =

10 =

11 = Lowest

Fine B:

0 = Blue channel fine clamp is off (default)

1 = Blue channel fine clamp is on, Recommended setting

Fine G:

0 = Green channel fine clamp is off (default)

1 = Green channel fine clamp is on, Recommended setting

Fine R:

0 = Red channel fine clamp is off (default)

1 = Red channel fine clamp is on, Recommended setting

NOTE:

Fine clamp must be turned on for proper clamp operation. See register 10h for mid and bottom level clamping control.

Power Control

Subaddress 2Bh

(Default 00h)

7	6	5	4	3	2	1	0
	SOG	SLICER	REF	CURRENT	PW ADC B	PW ADC G	PW ADC R

SOG:

0 = Normal operation (default)

1 = SOG power-down

Slicer:

0 = Normal operation (default)

1 = Slicer power-down

Reference:

0 = Normal operation (default)

1 = Reference block power-down

Current control:

0 = Normal operation (default)

1 = Current control block power-down

PW ADC B: Power-down ADC blue channel

0 = PW ADC R: Power-down ADC blue channel

1 = ADC channel 1 power-down

PW ADC G: Power-down ADC green channel

0 = PW ADC R: Power-down ADC green channel

1 = ADC channel 2 power-down

PW ADC R: Power-down ADC red channel

0 = PW ADC R: Power-down ADC red channel

1 = ADC channel 3 power-down

ADC Setup

Subaddress 2Ch

(Default 00h)

7	6	5	4	3	2	1	0
0	1	1	0	0	0	0	0

50h = Recommended setting

Coarse Clamp Control

Subaddress 2Dh

Default (00h)

7	6	5	4	3	2	1	0
CCCLP_cur_CH1		Reserved			Coarse B	Coarse G	Coarse R

Coarse clamp charge current switch selection:

- 00 = Highest (default)
- 01 =
- 10 =
- 11 = Lowest

Course B:

- 0 = Coarse clamp off at BLUE channel (default)
- 1 = Coarse clamp on at BLUE channel

Coarse G :

- 0 = Coarse clamp off at GREEN channel (default)
- 1 = Coarse clamp on at GREEN channel

Coarse R :

- 0 = Coarse clamp off at RED channel (default)
- 1 = Coarse clamp on at RED channel

SOG Clamp

Subaddress 2Eh

(Default 00h)

7	6	5	4	3	2	1	0
SOG_CE	Reserved						

SOG_CE:

- 0 = SOG Clamp disabled (default)
- 1 = SOG Clamp enabled. Set to 1 for SOG operation.

ALC Placement

Subaddress 31h

(Default 00h)

7	6	5	4	3	2	1	0
ALC placement [7:0]							

ALC placement [7:0]:

- 0 = Default
- 18h = PC graphics and SDTV with bi-level syncs
- 5Ah = HDTV with tri-level syncs

Positions the ALC signal an integer number of clock periods after the HSYNC signal. ALC must be applied after the clamp end.

APPLICATION INFORMATION

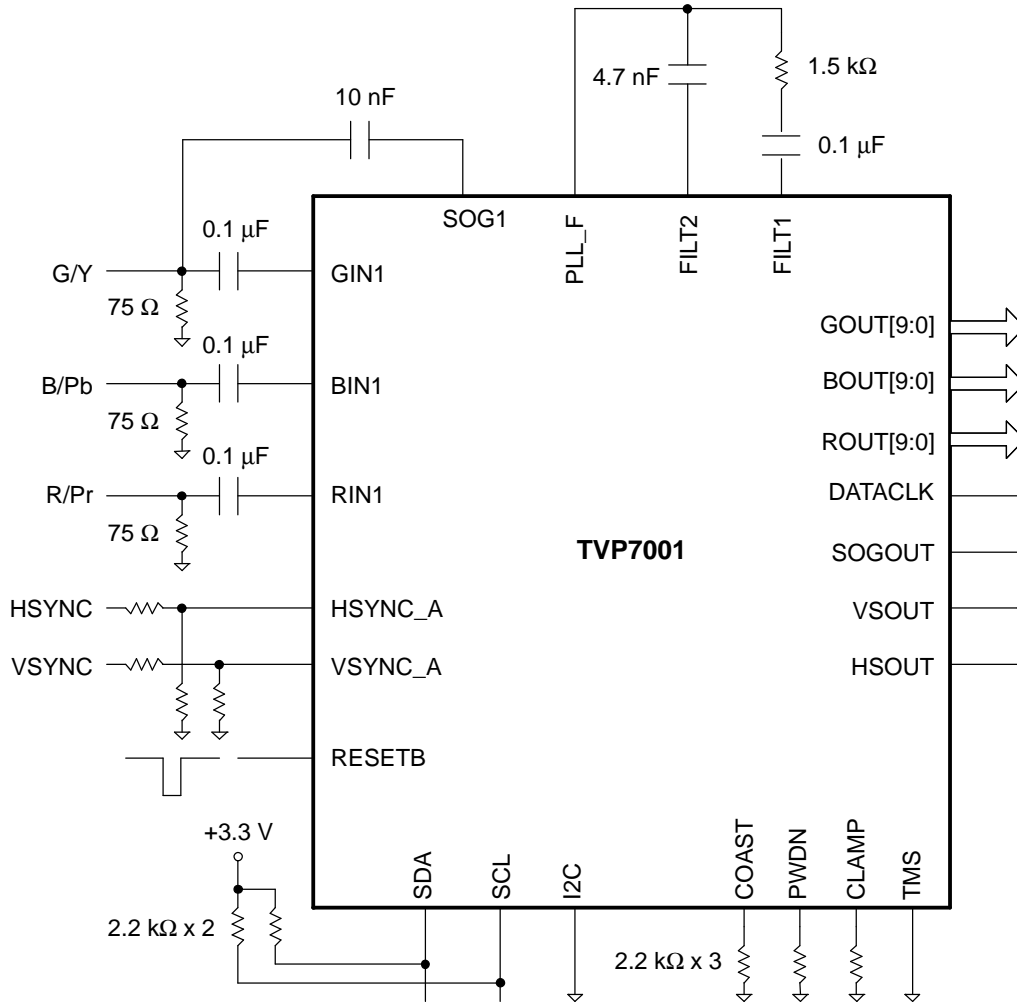
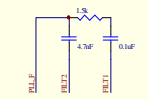
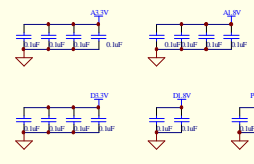

Figure 8. TVP7001 Application Example

Schematic



I2C ADDRESS SELECTION

2-3: Base Addr 0x8A
 1-2: Base Addr 0x8B - Default

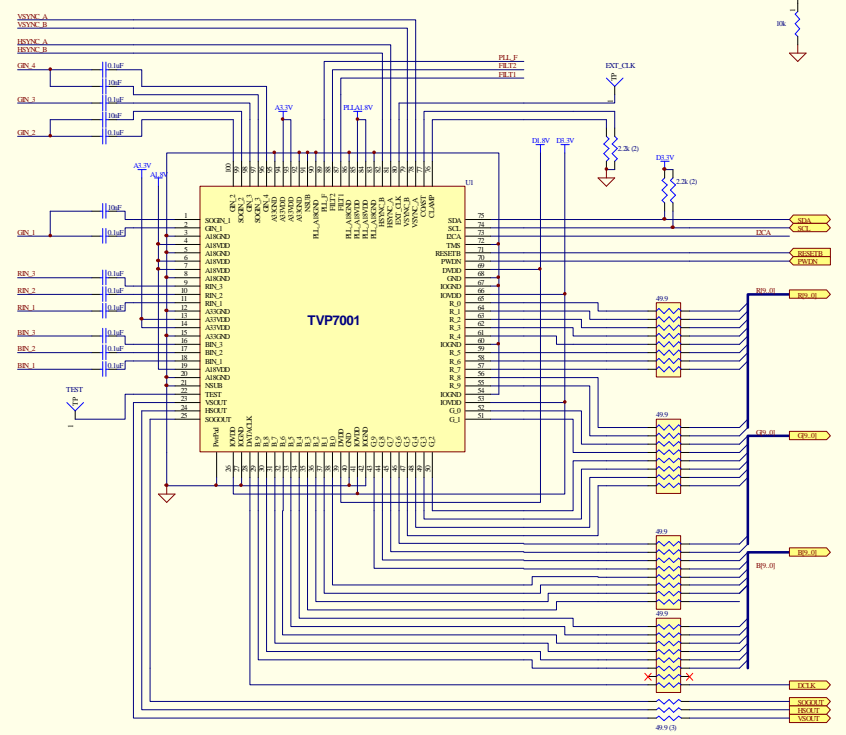
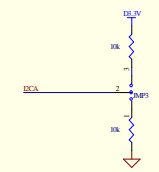

Title		TVP7001	
Size	Number	Revision	REV 1.1
Date	31-Aug-2016	Sheet of	1
File: C:\Documents and Settings\g14085\My Documents\TVP7001\TVP7001 ENMODULE_REV1.0.dwg			

PZP (S-PQFP-G100)

PowerPAD™ PLASTIC QUAD FLATPACK

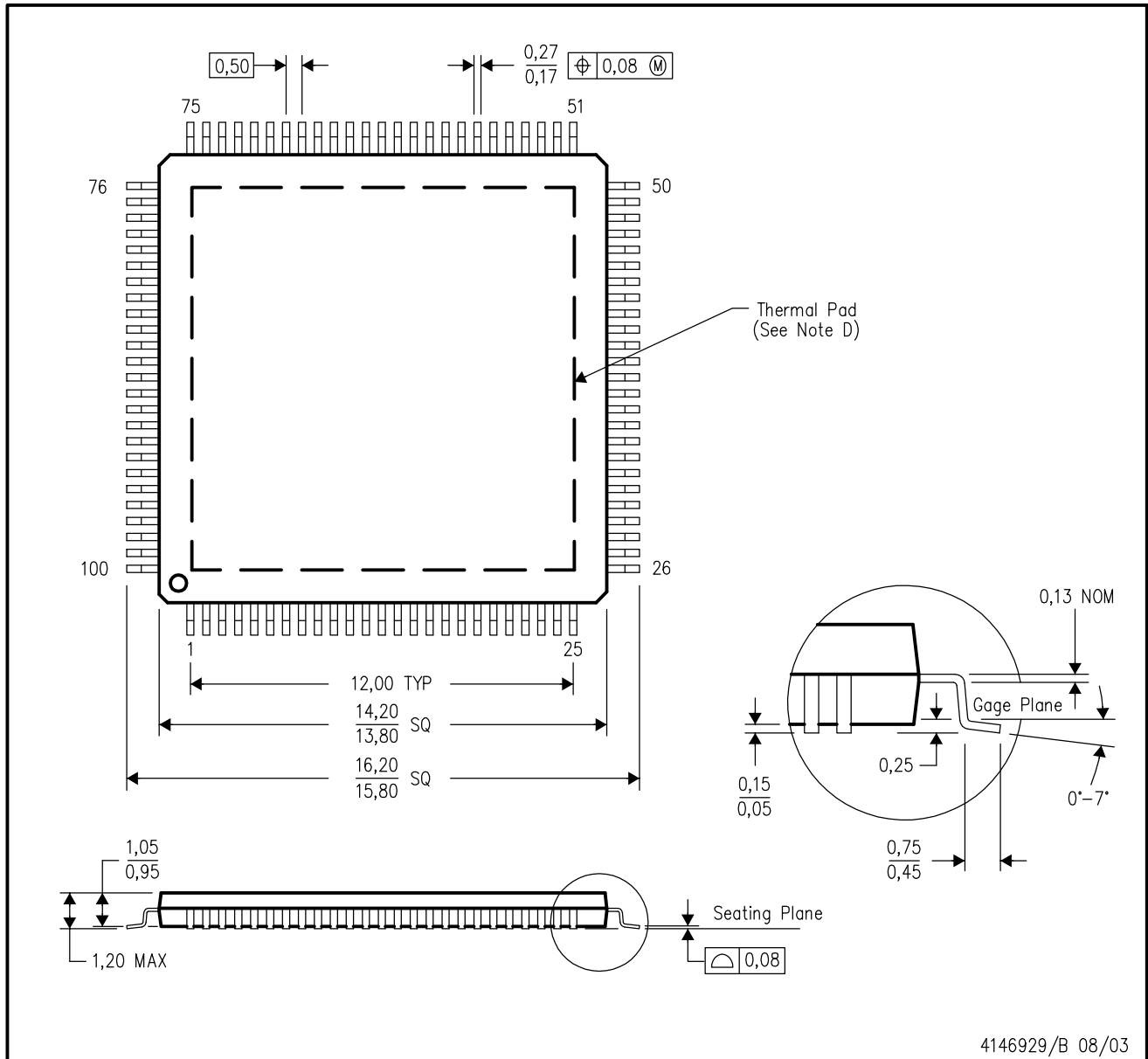

- NOTES:
- A. All linear dimensions are in millimeters.
 - B. This drawing is subject to change without notice.
 - C. Body dimensions do not include mold flash or protrusion
 - D. This package is designed to be molded to a thermal pad on the board. Refer to Technical Brief, PowerPad Thermally Enhanced Package, Texas Instruments Literature No. SLMA002 for information regarding recommended board layout. This document is available at www.ti.com <<http://www.ti.com>>.
 - E. Falls within JEDEC MS-026

PowerPAD is a trademark of Texas Instruments.

THERMAL INFORMATION

This PowerPAD™ package incorporates an exposed thermal pad that is designed to be attached directly to an external heatsink. When the thermal pad is soldered directly to the printed circuit board (PCB), the PCB can be used as a heatsink. In addition, through the use of thermal vias, the thermal pad can be attached directly to a ground or power plane (whichever is applicable), or alternatively, a special heatsink structure designed into the PCB. This design optimizes the heat transfer from the integrated circuit (IC).

For additional information on the PowerPAD package and how to take advantage of its heat dissipating abilities, refer to Technical Brief, PowerPAD Thermally Enhanced Package, Texas Instruments Literature No. SLMA002 and Application Brief, PowerPAD Made Easy, Texas Instruments Literature No. SLMA004. Both documents are available at www.ti.com.

The exposed thermal pad dimensions for this package are shown in the following illustration.

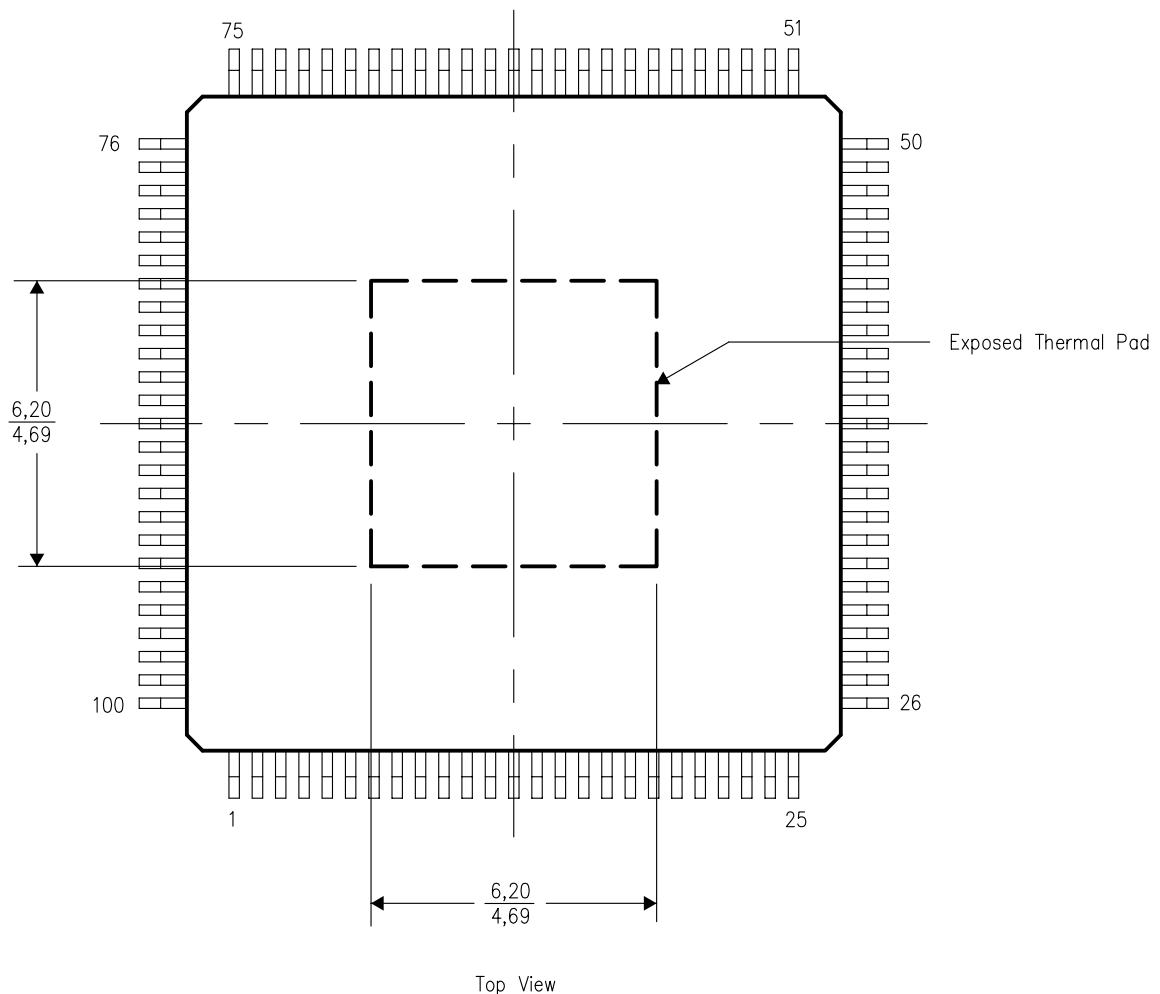

NOTE: All linear dimensions are in millimeters

Exposed Thermal Pad Dimensions

TRAY

Chamfer on Tray corner indicates Pin 1 orientation of packed units.

*All dimensions are nominal

Device	Package Name	Package Type	Pins	SPQ	Unit array matrix	Max temperature (°C)	L (mm)	W (mm)	K0 (µm)	P1 (mm)	CL (mm)	CW (mm)
TVP7001PZP	PZP	HTQFP	100	90	6 X 15	150	315	135.9	7620	20.3	15.4	15.45

GENERIC PACKAGE VIEW

PZP 100

PowerPAD™ TQFP - 1.2 mm max height

14 x 14 mm Pkg Body, 0.5 mm pitch
16 x 16 mm Pkg Area

PLASTIC QUAD FLATPACK

This image is a representation of the package family, actual package may vary.
Refer to the product data sheet for package details.

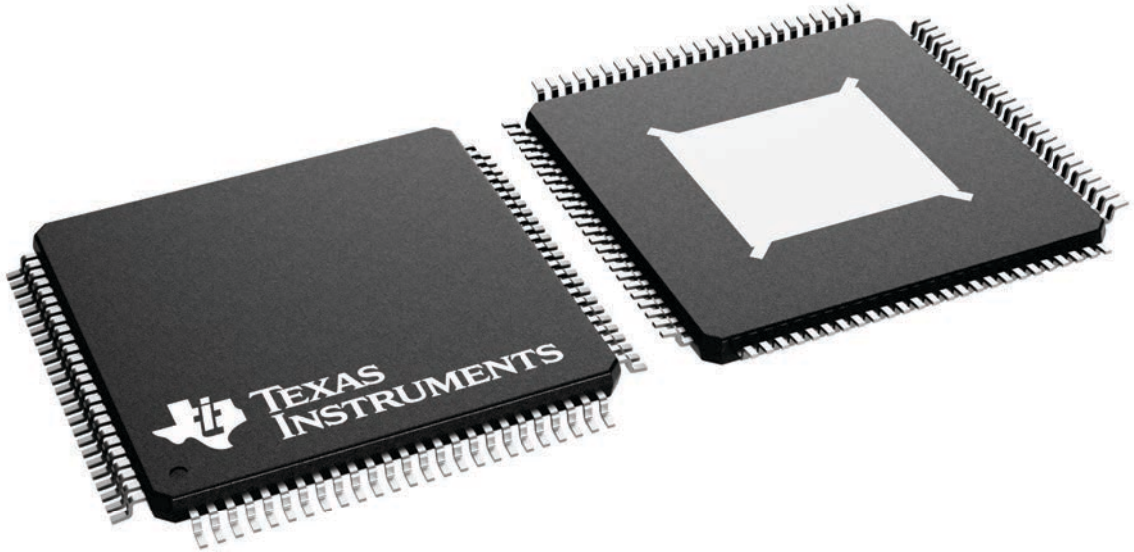

MECHANICAL DATA

PZP (S-PQFP-G100)

PowerPAD™ PLASTIC QUAD FLATPACK

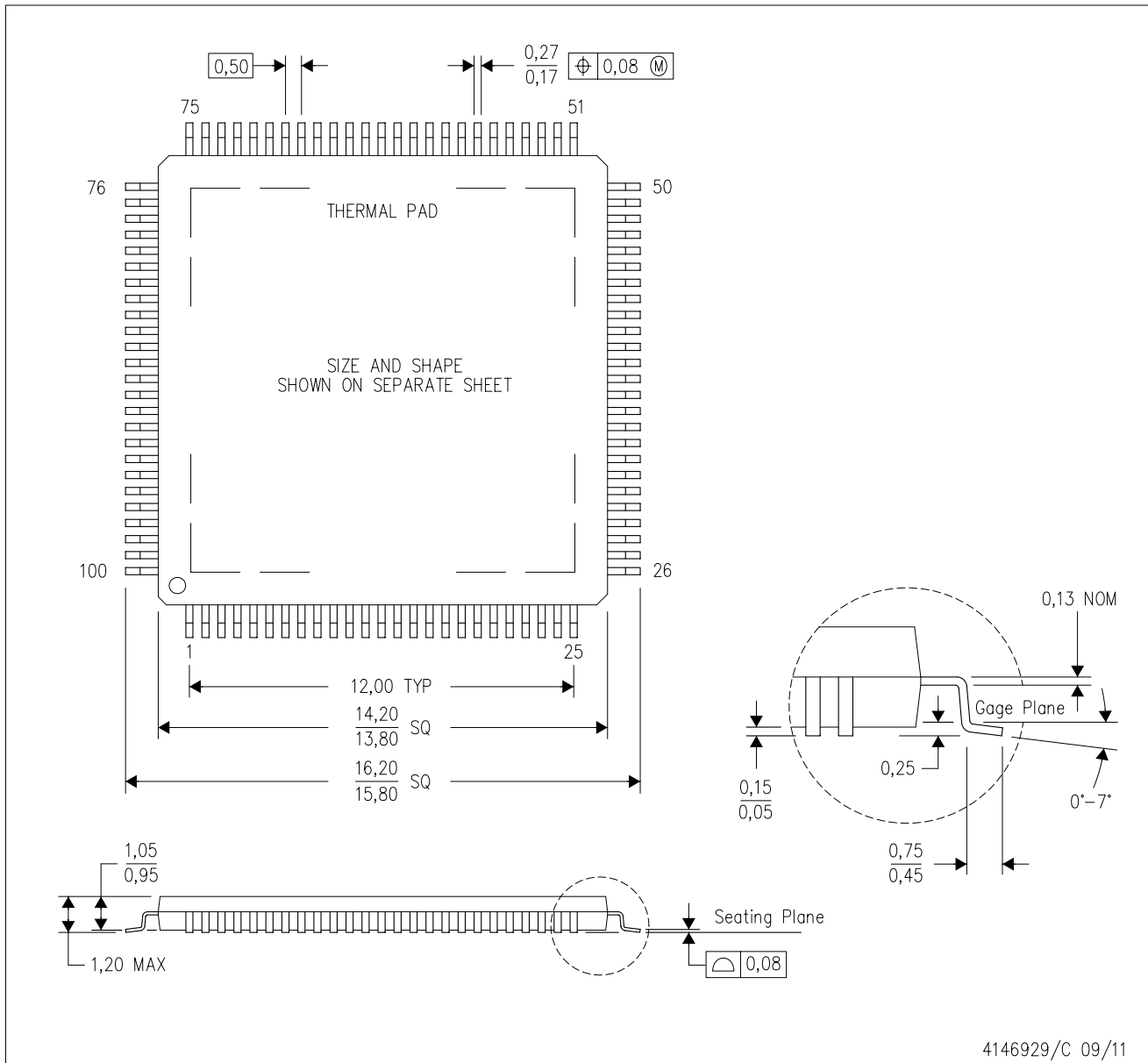

- NOTES:
- A. All linear dimensions are in millimeters.
 - B. This drawing is subject to change without notice.
 - C. Body dimensions do not include mold flash or protrusion
 - D. This package is designed to be soldered to a thermal pad on the board. Refer to Technical Brief, PowerPad Thermally Enhanced Package, Texas Instruments Literature No. SLMA002 for information regarding recommended board layout. This document is available at www.ti.com <<http://www.ti.com>>.
 - E. See the additional figure in the Product Data Sheet for details regarding the exposed thermal pad features and dimensions.
 - F. Falls within JEDEC MS-026

PowerPAD is a trademark of Texas Instruments.

THERMAL PAD MECHANICAL DATA

PZP (S-PQFP-G100)

PowerPAD™ PLASTIC QUAD FLATPACK

THERMAL INFORMATION

This PowerPAD™ package incorporates an exposed thermal pad that is designed to be attached to a printed circuit board (PCB). The thermal pad must be soldered directly to the PCB. After soldering, the PCB can be used as a heatsink. In addition, through the use of thermal vias, the thermal pad can be attached directly to the appropriate copper plane shown in the electrical schematic for the device, or alternatively, can be attached to a special heatsink structure designed into the PCB. This design optimizes the heat transfer from the integrated circuit (IC).

For additional information on the PowerPAD package and how to take advantage of its heat dissipating abilities, refer to Technical Brief, PowerPAD Thermally Enhanced Package, Texas Instruments Literature No. SLMA002 and Application Brief, PowerPAD Made Easy, Texas Instruments Literature No. SLMA004. Both documents are available at www.ti.com.

The exposed thermal pad dimensions for this package are shown in the following illustration.

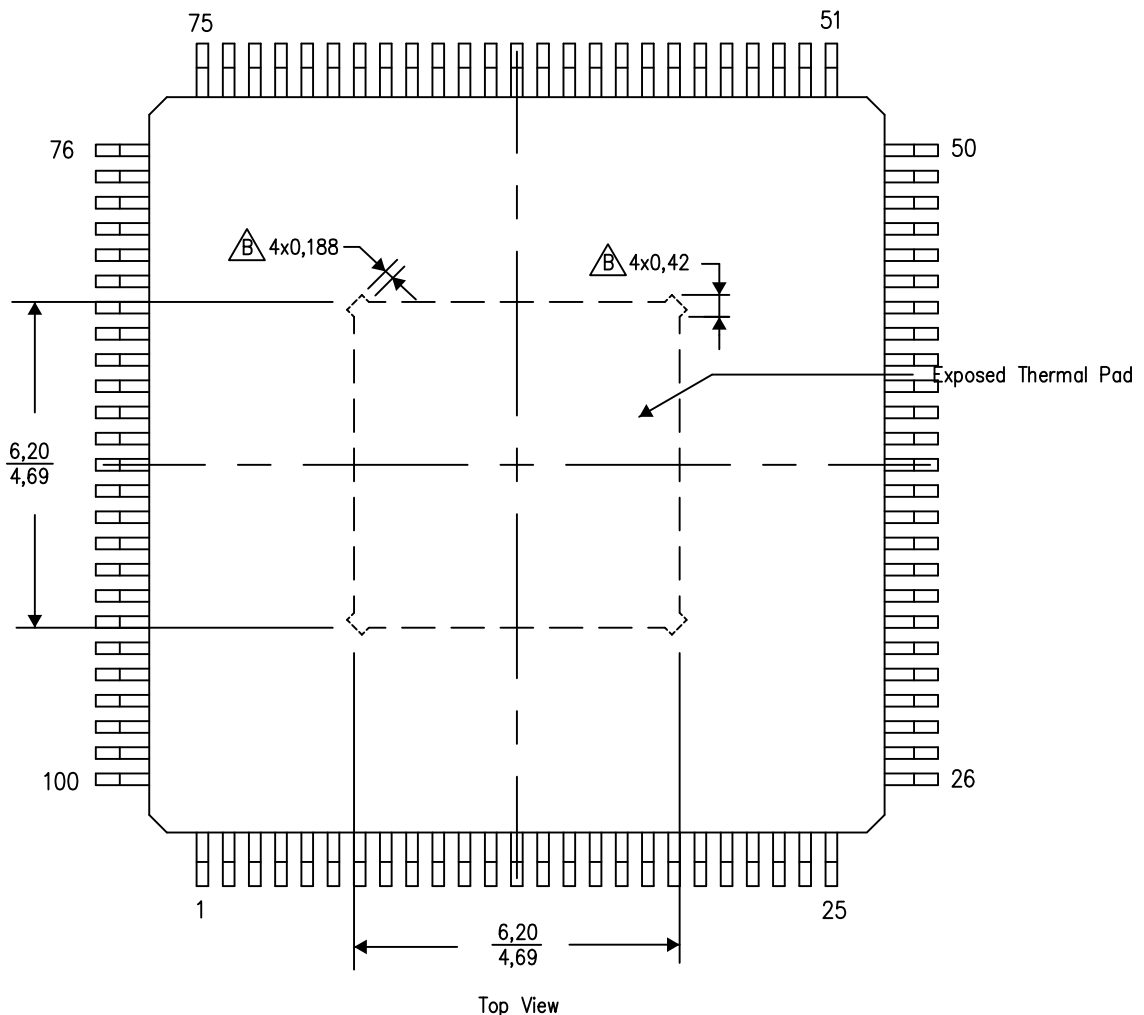

Exposed Thermal Pad Dimensions

4206333-3/L 05/14

NOTE: A. All linear dimensions are in millimeters

 Tie strap features may not be present.

PowerPAD is a trademark of Texas Instruments

IMPORTANT NOTICE AND DISCLAIMER

TI PROVIDES TECHNICAL AND RELIABILITY DATA (INCLUDING DATA SHEETS), DESIGN RESOURCES (INCLUDING REFERENCE DESIGNS), APPLICATION OR OTHER DESIGN ADVICE, WEB TOOLS, SAFETY INFORMATION, AND OTHER RESOURCES "AS IS" AND WITH ALL FAULTS, AND DISCLAIMS ALL WARRANTIES, EXPRESS AND IMPLIED, INCLUDING WITHOUT LIMITATION ANY IMPLIED WARRANTIES OF MERCHANTABILITY, FITNESS FOR A PARTICULAR PURPOSE OR NON-INFRINGEMENT OF THIRD PARTY INTELLECTUAL PROPERTY RIGHTS.

These resources are intended for skilled developers designing with TI products. You are solely responsible for (1) selecting the appropriate TI products for your application, (2) designing, validating and testing your application, and (3) ensuring your application meets applicable standards, and any other safety, security, regulatory or other requirements.

These resources are subject to change without notice. TI grants you permission to use these resources only for development of an application that uses the TI products described in the resource. Other reproduction and display of these resources is prohibited. No license is granted to any other TI intellectual property right or to any third party intellectual property right. TI disclaims responsibility for, and you will fully indemnify TI and its representatives against, any claims, damages, costs, losses, and liabilities arising out of your use of these resources.

TI's products are provided subject to [TI's Terms of Sale](#) or other applicable terms available either on [ti.com](https://www.ti.com) or provided in conjunction with such TI products. TI's provision of these resources does not expand or otherwise alter TI's applicable warranties or warranty disclaimers for TI products.

TI objects to and rejects any additional or different terms you may have proposed.

Mailing Address: Texas Instruments, Post Office Box 655303, Dallas, Texas 75265
Copyright © 2023, Texas Instruments Incorporated