

PR212
Spartan™-IIE Design 3
TPS64203 Switching DC/DC Controller-Based Power Management Solution Providing
up to 3 A from $V_{IN} = 5.0\text{ V}$ or 3.3 V

FEATURES:

- Tiny SOT-23 switching DC/DC controller, U2, delivers up to 3 A at low cost.
- Easily customizable design allows for maximum cost control by:
 - o Sizing Q1 for the amount of current up to 3 A to meet the application's I_{CCINT} requirement,
 - o Omitting current sense resistor R1 and connecting ISNS to the drain of Q1,
 - o Selecting the linear regulator from the TPS79xxx family to meet the application's I_{CCO} requirement.
- In-rush current (for charging decoupling capacitors and FPGA start-up) that places a demand on the input power supply is minimized by the use of the:
 - o External supervisory (SVS) IC, U1, which monitors the input rail and prevents the regulator from enabling until the input bulk capacitors (not shown in the schematic) are fully charged.
 - o Integrated soft-start of U2 with assistance from the additional soft-start circuitry (R7, R8, R9, C4 and Q4) provides 2.5 ms rise time for V_{CCINT} .
 - o Sequential sequencing of V_{CCINT} then V_{CCO} using the discrete SVS circuit formed by bipolar transistors Q2 and Q3 and supporting passives to enable the V_{CCO} regulator, U3
- The design meets Xilinx's V_{CCINT} and V_{CCO} start-up profile requirements, where applicable, including monotonic voltage ramp, in-rush current and power voltage ramp time requirements.

IMPORTANT WEB LINKS:

- Link to the TI home page for Xilinx FPGA power management solutions at <http://www.ti.com/xilinuxfpga> for more information and other reference designs.
- Link to datasheets at <http://focus.ti.com/lit/ds/symlink/tps64203.pdf>, <http://focus.ti.com/lit/ds/symlink/tps78601.pdf>, and <http://focus.ti.com/lit/ds/symlink/tlc7705.pdf>.
- Link to application note SLVA118 <http://focus.ti.com/lit/an/slva118/slva118.pdf> to explore the thermal considerations in using linear regulators.
- Link to application note SLVA160 <http://focus.ti.com/lit/an/slva160/slva160.pdf> for guidance on selecting a different option from the TPS642xx family.

IMPLEMENTATION NOTES:

- **Sequencing:** Although Xilinx FPGAs **do NOT require it**, this reference design employs sequencing. This practice is consistent with good power supply design

and prevents the input power supply from being pulled down due to supporting in-rush currents for charging large capacitive loads.

- **V_{CCINT} minimum ramp time:** Met by integrated soft-start of U2 with assistance from the additional soft-start circuitry (R7, R8, R9, C4 and Q4).
- **I_{CCINT} inrush current:** Mitigated by softstart.
- **Power Dissipation/Thermal Issues:** Refer to the application section of the linear regulator datasheet for maximum power dissipation at different ambient conditions as well as guidance on sizing the ground plane area underneath the package for heatsinking.
- **Designing with the TPS64203:**
 - o The TPS64203 controller has limited current to drive the gate of the PMOS transistor, Q1. To ensure proper operation of the controller, a PMOS transistor with a maximum total gate charge, Q_g, of less than 50 nC is required.
 - o Omitting current sense resistor R1 and connecting ISNS to the drain of Q1, thereby using the R_{DSon} of Q1 as the current sense, results in an effective, but slightly less accurate, current limit function.
- **Soft Start Circuitry:** Although only 100 uF of output capacitance is recommended for the TPS64203 controller to operate when providing 3A, the output of the controller needs at least 470 uF of total capacitance in order for the additional soft-start circuitry (R7, R8, R9, C4 and Q4) to work properly. The additional bulk bypass capacitance (not shown in the schematic) required for the V_{CCINT} rail of the FPGA will most likely meet this requirement.
- **Layout:** The 1.0 uF capacitor, C7, should be placed as close as possible between VDD and GND of the TLC77xx SVS IC.
- **Modifications:**
 - o CT of TLC7705 is not connected, but can be used with a capacitor to add a delay between the 5 V rail coming up and RST = /EN of TPS64203.
 - o Adapt for 3.3V supply by:
 - Omitting U3 circuit,
 - Replacing TLC7705 with TLC7733.
 - o For a low-cost, discrete Supply Voltage Supervisory Circuit alternative to U1, please see reference design PR286 (Active-High Reset Output) or PR281 (Active-Low Reset Output).

QUESTIONS?

- Send an email to <mailto:fpgasupport@list.ti.com>

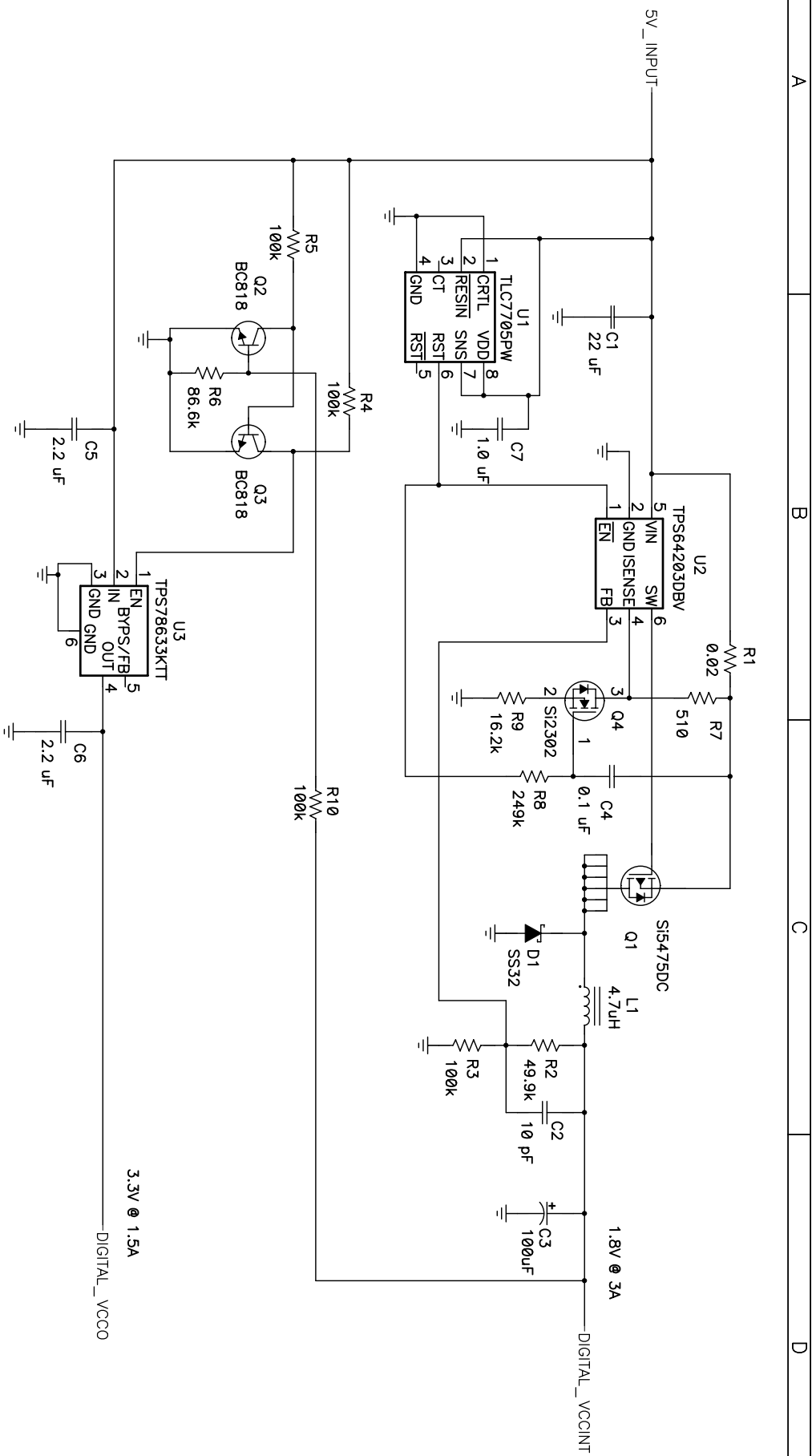

Title		Spartan-IIe Controller	
Size	Number	PR212	Rev
B			
Date	8/19/04	Drawn by	
Filename	pr212.sch	Sheet	of

Filename: PR212_bom.xls					
Date: 08/19/2004					
PR212 BOM					
COUNT	RefDes	Description	SIZE	MFR	Part Number
1	C1	Capacitor, Ceramic, 22-uF, 10-V, X5R, 10%	1210	muRata	GRM32ER61A226KA65
2	C2, C4	Capacitor, Ceramic, 10-pF, 50-V, C0G, +/- 5pF	603	TDK	C1608C0G1H100D
1	C3	Capacitor, Tantalum, 100-uF, 10-V, 80-milliohm, 20%	7343 (D)	Vishay	593D107X0010D2T35
2	C5, C6	Capacitor, Ceramic, 2.2-uF, 6.3-V, X5R, 10%	805	muRata	GRM21BR60J225KC01
1	C7	Capacitor, Ceramic, 1.0-uF, 6.3-V, X5R, 10%	603	muRata	GRM188R60J105KA01
1	D1	Diode, Schottky Barrier Rectifier, 3-A, 20-V	SMC	Vishay	SS32
1	L1	Inductor, High Current, SMT, 4.7-uH, 5.4-A, 18-milliohm	0.26x0.09	Vishay	IDC-5020NB4R7M
1	Q1	MOSFET, P-ch, 20V,4.8-A, 76-milliohm	1206-8	Siliconix	Si5475DC
2	Q2, Q3	Bipolar, NPN, 30-V, 800-mA, 310-mW	SOT23		BC818
1	Q4	MOSFET, N-ch, 20-V, 2.8-A, 85-milliOhms	SOT23		Si2302
1	R1	Resistor, Chip, 0.02-Ohms, 1/4-W, 1%	1210	Std	Std
1	R2	Resistor, Chip, 49.9k-Ohms, 1/16-W, 1%	603	Std	Std
4	R3, R4, R5, R10	Resistor, Chip, 100k-Ohms, 1/16-W, 1%	603	Std	Std
1	R6	Resistor, Chip, 86.6k-Ohms, 1/16-W, 1%	603	Std	Std
1	R7	Resistor, Chip, 510-Ohms, 1/16-W, 1%	603	Std	Std
1	R8	Resistor, Chip, 249k-Ohms, 1/16-W, 1%	603	Std	Std
1	R9	Resistor, Chip, 16.2k-Ohms, 1/16-W, 1%	603	Std	Std
1	U1	IC, Voltage Supervisor, Micropower	TSSOP-8	TI	TLC7705PW
1	U2	IC, Step-Down Controller	SOT23-6	TI	TPS64203DBV
1	U3	IC, Ultra Low-Noise, High PSRR, Fast RF 1.5A LDO Linear Regulator	DDPAK-5	TI	TPS78633KTT

IMPORTANT NOTICE

Texas Instruments Incorporated and its subsidiaries (TI) reserve the right to make corrections, modifications, enhancements, improvements, and other changes to its products and services at any time and to discontinue any product or service without notice. Customers should obtain the latest relevant information before placing orders and should verify that such information is current and complete. All products are sold subject to TI's terms and conditions of sale supplied at the time of order acknowledgment.

TI warrants performance of its hardware products to the specifications applicable at the time of sale in accordance with TI's standard warranty. Testing and other quality control techniques are used to the extent TI deems necessary to support this warranty. Except where mandated by government requirements, testing of all parameters of each product is not necessarily performed.

TI assumes no liability for applications assistance or customer product design. Customers are responsible for their products and applications using TI components. To minimize the risks associated with customer products and applications, customers should provide adequate design and operating safeguards.

TI does not warrant or represent that any license, either express or implied, is granted under any TI patent right, copyright, mask work right, or other TI intellectual property right relating to any combination, machine, or process in which TI products or services are used. Information published by TI regarding third-party products or services does not constitute a license from TI to use such products or services or a warranty or endorsement thereof. Use of such information may require a license from a third party under the patents or other intellectual property of the third party, or a license from TI under the patents or other intellectual property of TI.

Reproduction of information in TI data books or data sheets is permissible only if reproduction is without alteration and is accompanied by all associated warranties, conditions, limitations, and notices. Reproduction of this information with alteration is an unfair and deceptive business practice. TI is not responsible or liable for such altered documentation.

Resale of TI products or services with statements different from or beyond the parameters stated by TI for that product or service voids all express and any implied warranties for the associated TI product or service and is an unfair and deceptive business practice. TI is not responsible or liable for any such statements.

Following are URLs where you can obtain information on other Texas Instruments products and application solutions:

Products		Applications	
Amplifiers	amplifier.ti.com	Audio	www.ti.com/audio
Data Converters	dataconverter.ti.com	Automotive	www.ti.com/automotive
DSP	dsp.ti.com	Broadband	www.ti.com/broadband
Interface	interface.ti.com	Digital Control	www.ti.com/digitalcontrol
Logic	logic.ti.com	Military	www.ti.com/military
Power Mgmt	power.ti.com	Optical Networking	www.ti.com/opticalnetwork
Microcontrollers	microcontroller.ti.com	Security	www.ti.com/security
		Telephony	www.ti.com/telephony
		Video & Imaging	www.ti.com/video
		Wireless	www.ti.com/wireless

Mailing Address: Texas Instruments
Post Office Box 655303 Dallas, Texas 75265