

# TI TECH DAYS

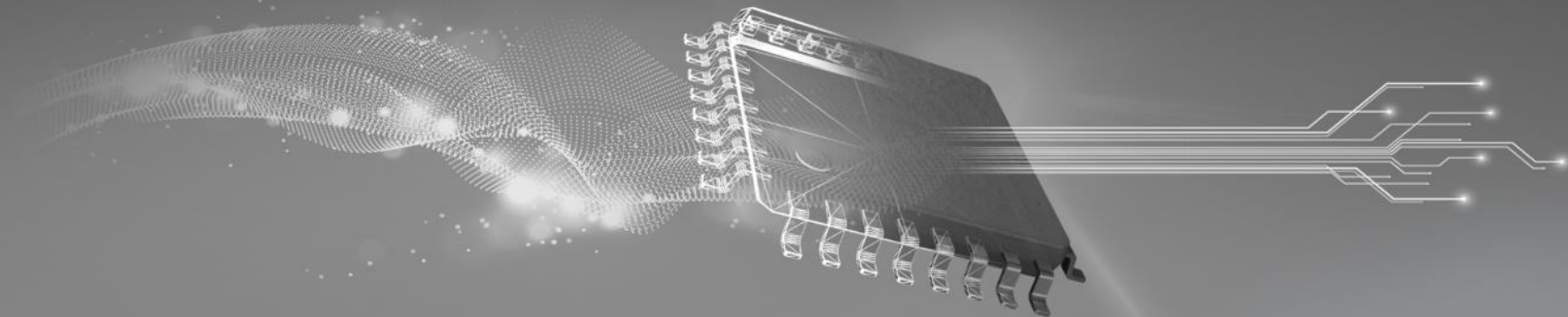

## Texas Instruments AWR6843 60-GHz sensor for incabin sensing

Dave Woodall

Radar

# mmWave Sensors – Technology Overview, TI Advantages and Applications

## What is mmWave Technology

- mmWave sensors provide **range**, **velocity** and **angle** for detected objects with high accuracy
- mmWave technology **works in challenging environmental conditions** such as darkness, extreme bright light, dust, rain, snow and extreme temperatures

## Texas Instruments mmWave Advantages

- **Single-chip, Low-power** sensing solution achieved through RFCMOS technology
- **Integrated processing** solutions remove the need for an external processor in the system
- **Scalable Portfolio** – SW re-use across Automotive & Industrial platforms, regardless of band
- **Antenna on Package** – Optimized solution simplifies design & manufacturing challenges
- **Imaging Radar** – Lidar-like performance at the right price point

## mmWave Applications

### Automotive



### Industrial



# Front Mount Vehicle Occupancy Detection

- Reference Design Number: TIDEP-01001: [www.ti.com/tool/tidep-01001](http://www.ti.com/tool/tidep-01001)
- AWR6843 – TI's FMCW mmWave (60-64GHz) **Single chip Radar** with 3Tx/4Rx RF front End, ADC, DSP(C674x) and MCU(Cortex-R4F), FFT/CFAR accelerator.
- AWR1843 – TI's FMCW mmWave (76-81GHz) **Single chip Radar**
- Complete RADAR data processing on-board the device.
- Device outputs heatmap, feature and zone decision information.
- Chirping pattern provides ability to detect small movements, such as breathing and heart rate.

## Demonstration using AWR6843 EVM

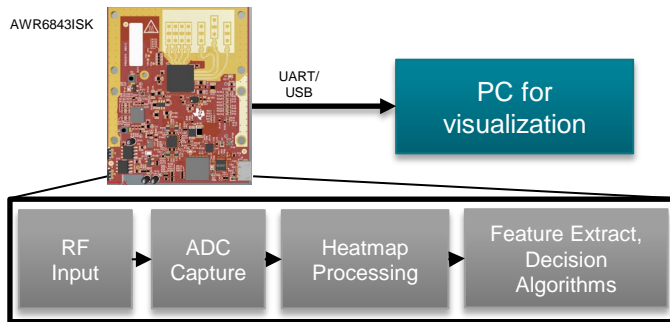

# HW & SW Compatible AWR1843 (77 GHz) & AWR6843 (60 GHz)

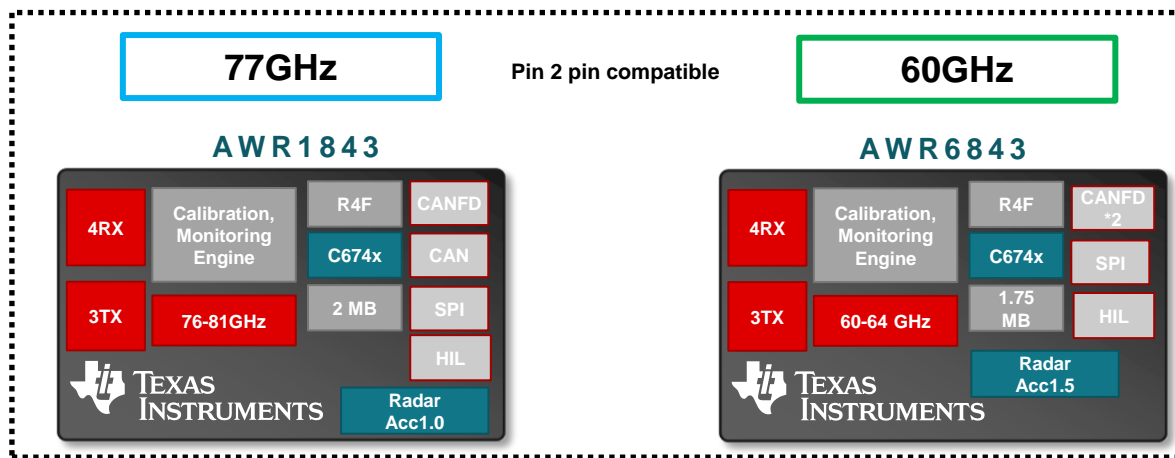

Function	AWR1843 (77GHz)	AWR6843 (60GHz)
Continuous Bandwidth	4GHz	4 GHz
I/F Bandwidth	10MHz	10MHz
RAM	2MB	1.75MB

- mmWave-SDK supports both 77GHz and 60GHz platform
- Common device architecture
- Same software API's for development
- Pin 2 Pin compatible
- Radar Accelerator 1.5 has **Memory Compression unit**
- AWR6843** in production!

# VOD Antenna Overview

The [Front Mount Vehicle Occupancy Detection demo](#) was originally developed on the AWR1642BOOST EVM. With [AWR6843](#) and 1843, we perform TDM MIMO with the azimuth antennas to create a 1x8 virtual antenna pattern:

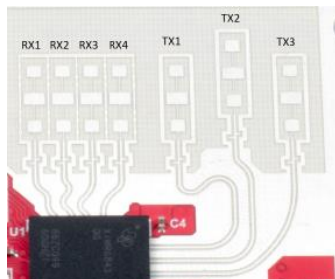

IWR6843 AOP and ODS antennas create a different virtual array:

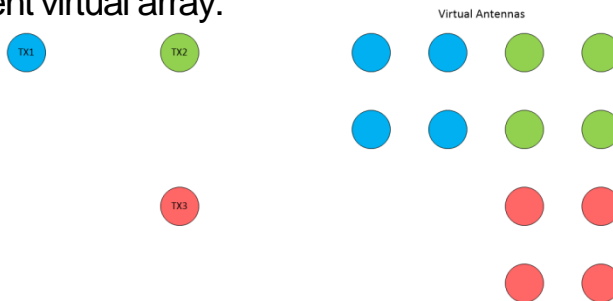
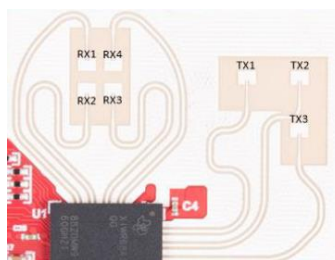

This antenna is used for the [Overhead Mount VOD demo](#) and “3D” algorithms make use of both azimuth and elevation data.

# Front Mount Implementation Overview

## Hardware

- AWR6843ISK
  - 4 RX, 3TX
  - DSP, ARM
  - RF Front end
  - FFT accelerator

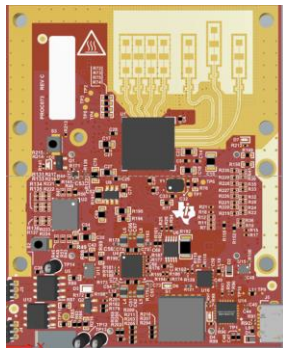

## Software

TI Resource Explorer

Vehicle Occupant Detection

- User's Guide
- PC GUI
- Release Notes
- CCS Project - MSS 16xx
- CCS Project - DSS 16xx
- CCS Project - MSS 18xx
- CCS Project - DSS 18xx
- CCS Project - MSS 68xx
- CCS Project - DSS 68xx

Vehicle Occupancy Detection User's Guide

### Overview

This lab demonstrates the use of TI mmWave sensors to detect people and animals in pre-defined zones of coverage. Using TI 60GHz AWR6843, and 77GHz AWR1843 and AWR1642 mmWave devices, algorithms run onboard the single-chip device to create a Range-Azimuth heatmap, then extract features and detections from the heatmap. Chirp configurations are selected to detect slight movements (like breathing) with a high degree of accuracy. Two use cases are supported - Vehicle Occupancy Detection (VOD) and Child Presence Detection (CPD).

## Key Performance Specifications

Parameter	Value
Max range	3.3 m
Max velocity	2.78 m/s
Range resolution	4.69cm
Velocity resolution	0.013 m/s
Field of View	120° Horizontal
Bandwidth	3.920 GHz

- mmwave\_automotive\_toolbox\_3\_x\_x
  - Available in TI Resource Explorer
  - (within CCS, or <http://dev.ti.com/tirex/explore>)
- mmWave SDK
  - Installer here: [www.ti.com/tool/mmwave-sdk](http://www.ti.com/tool/mmwave-sdk)

# VOD Chirp Configuration Features

- TDM 2x4 MIMO
  - Suitable for applications which require a high angular resolution
  - Angular resolution determined by the virtual antenna.
- 512 Chirps/frame for high velocity resolution to detect slow movement like breathing
  - 256 TX1 chirps interlaced with
  - 256 TX3 chirps.
  - Large chirp cycle time = 290us
- Maximize range resolution while fitting in a 512KB radar cube:
  - num samples = 64
  - sample rate = 2200ksp/s
  - freq slope = 98 Mhz/us

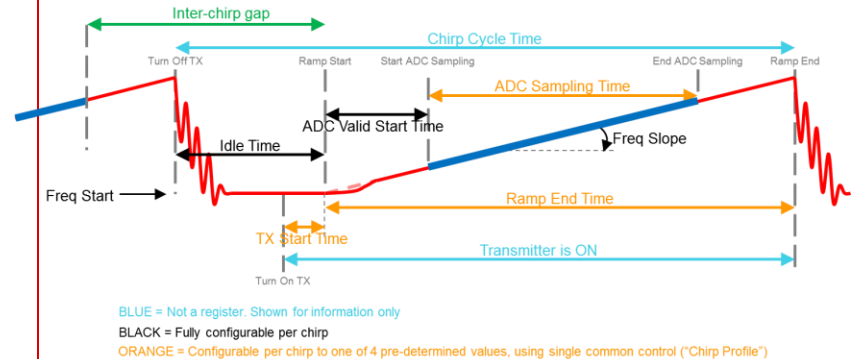
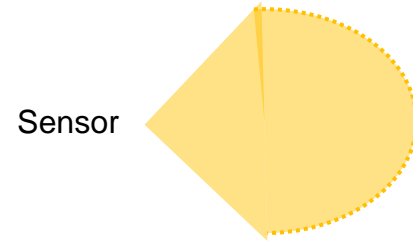





# Front End and Range (Chirp) Processing

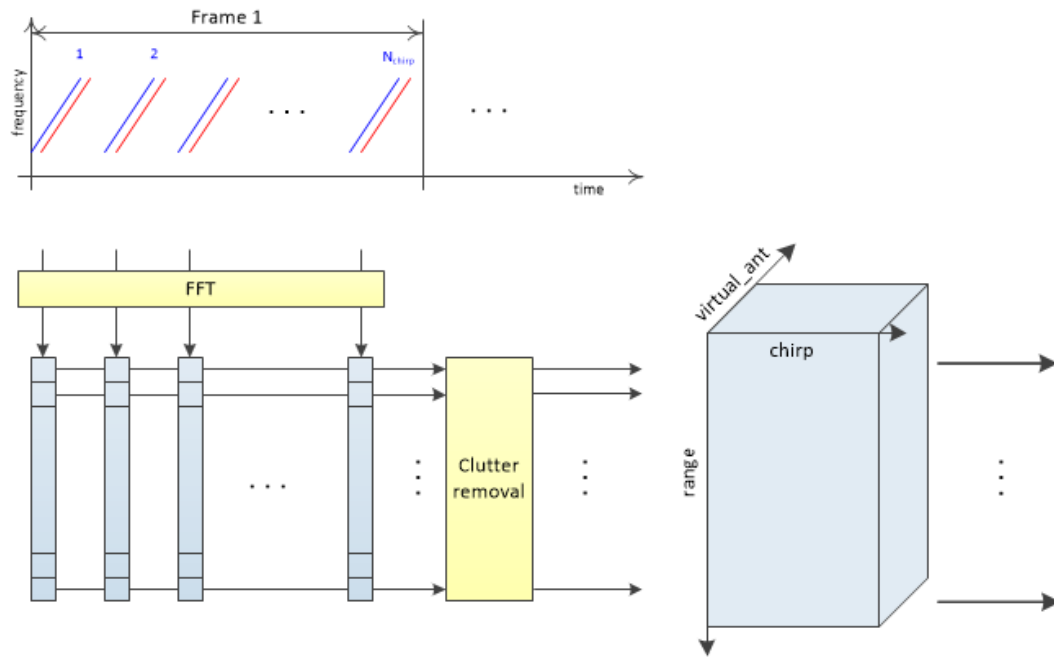

- Range processing performs FFT on ADC samples per antenna per chirp. FFT output is a set of range bins.
- Range processing results in local scratch buffers are DMA'd to the L3 radar cube.
- Static clutter removal is performed once radar cube is complete (following chirping).

# Static Clutter Removal

- Non moving objects in the vehicle can create strong returns in the data:
  - Seat structure
  - Items left on seats or cargo area
- Clutter removal eliminates most static objects, improving the signal for moving objects.
- Static clutter removal is performed by subtracting the estimated DC component (average power) from each range bin.

Without Clutter Removal

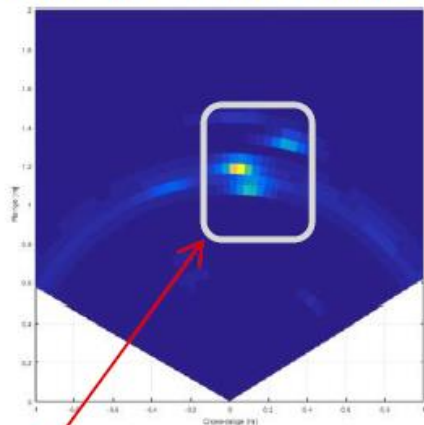

Strong clutter from vehicle structure dominates the human object

With Clutter Removal

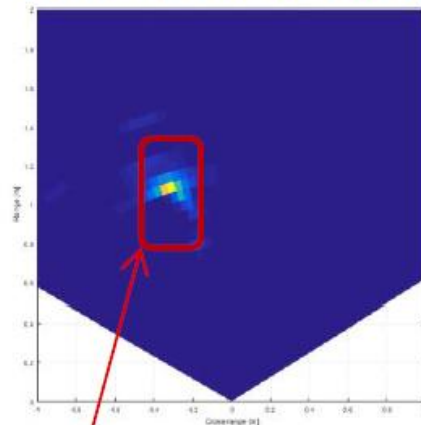

Clear signature from human object with clutter removal

# Range-Azimuth Heatmap Processing

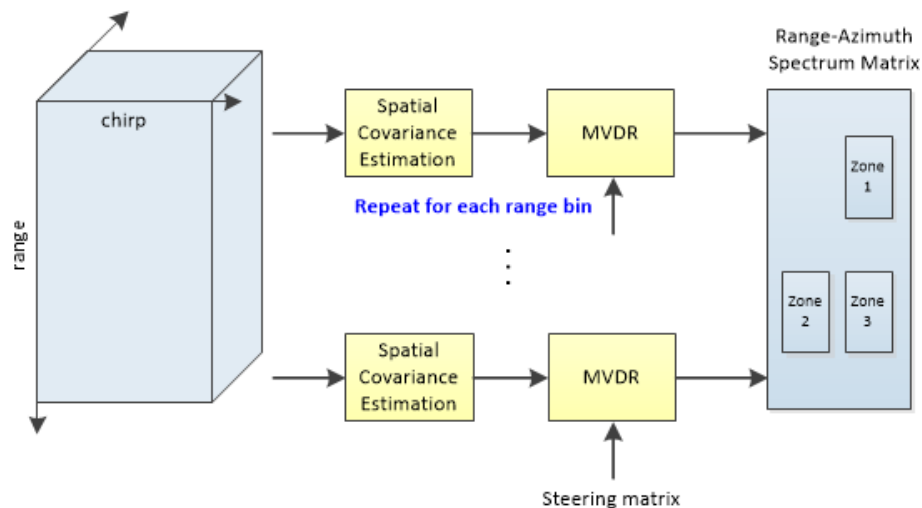

- Perform a high resolution Direction-of-Arrival (DOA) Spatial Estimation to calculate a 2D heatmap for the frame:
  - Spatial Covariance estimation is performed by stacking range bins across antennas, per  $n^{\text{th}}$  range bin and  $k^{\text{th}}$  chirp.
  - DOA estimation uses MVDR (minimum variance distortionless response, or Capon beamforming) to compute the angular spectrum for each range bin.

# Zone Processing (Feature Extract and Detection)

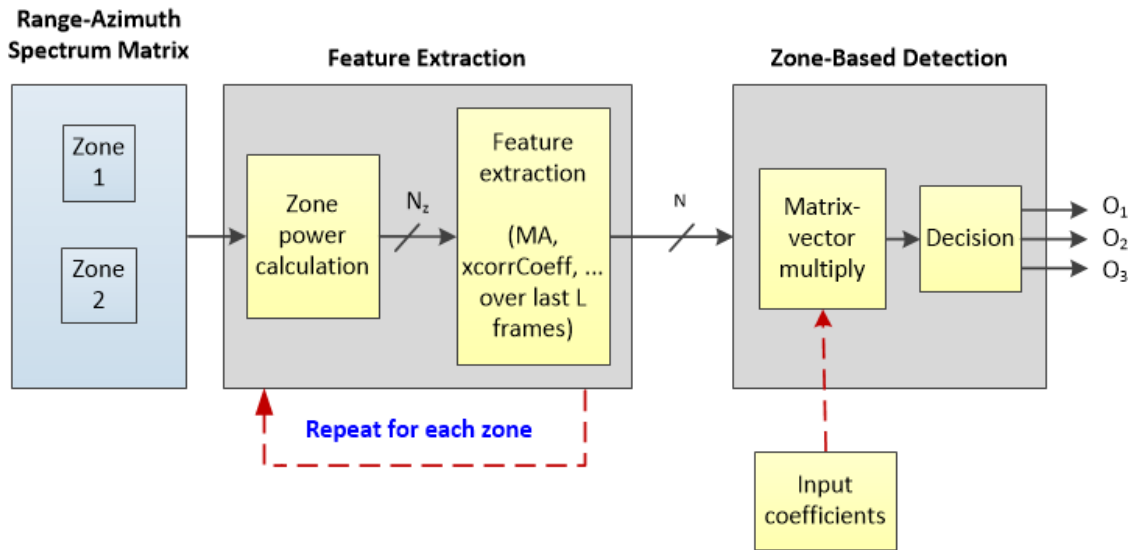

- Each frame, scan the heatmap within each defined zone of interest and compute a feature vector:
  - Zone power determined from max 5x5 region, moving-average zone power (for  $L$  (window length), frames).
  - Moving-average power ratio (for  $L$  frames), Correlation coefficient of zone power.
- Perform matrix multiplication with the input coefficients and the feature vector. This yields an array of flags, one flag per zone, a '1' indicating 'zone occupied', and '0' indicating 'empty'.

# Example Heatmap with Zone Detections

- Large values means more movement, shown with brighter colors.
- Here, 2 front and 3 back zones are defined.
- Static objects are removed.

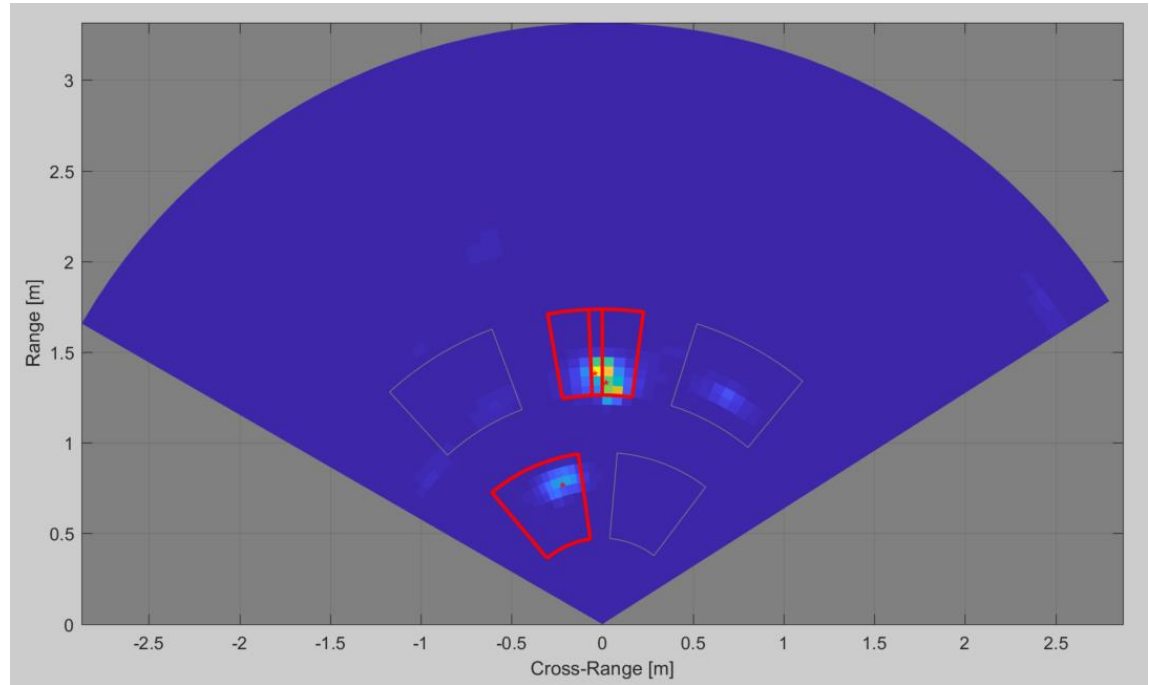

# Overhead Mount Vehicle Occupancy Detection Reference Design

- Reference Design Number: tbd:
- AOP and ODS – TI's FMCW mmWave (60-64GHz) **Single chip Radar** with 3Tx/4Rx RF front End, ADC, DSP(C674x) and MCU(Cortex-R4F), FFT/CFAR accelerator.
- Range processing performed on HWA.
- Device outputs 3D point cloud (currently), plan is to also output zone decision information.
- Chirping pattern provides ability to detect small movements, such as breathing and heart rate.



## Demonstration using [IWR6843AOPEVM](#)

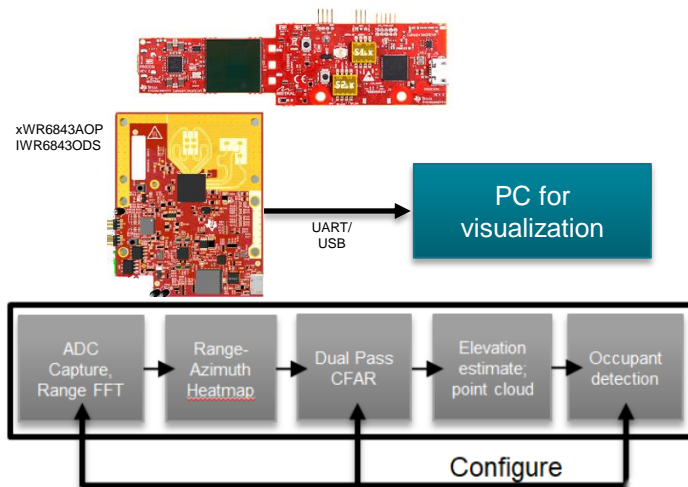

# Overhead Mount Implementation Overview

## Hardware

- AOP/ODS
  - 4 RX, 3TX
  - DSP, ARM
  - RF Front end
  - FFT accelerator

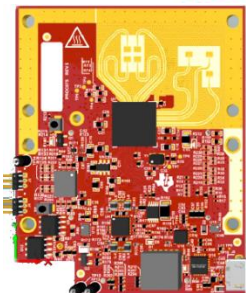

## Software

TI Resource Explorer

Software / mmWave Sensors / Automotive Toolbox (3.0.0) / Labs / Vehicle Occupant Detection

- C2000Ware\_DigitalPower\_SDK - 3.00.00.00
- C2000Ware\_MotorControl\_SDK - 3.00.00.00
- Energy
- mmWave Sensors
  - Automotive Toolbox - 3.0.0
    - Antenna Database
    - Experiments
    - Labs
      - Automated Parking
      - CAN SBL
      - Driver Vital Signs
      - MRR Beam Steering
      - Medium Range Radar
      - Multi Gesture
      - Non-OS mmWave SDK Demo
      - Object Data Over CAN
      - Obstacle Detection
      - Occupancy and Vital Signs Detection
      - Short Range Radar
      - Vehicle Occupant Detection
    - mmWave SDK CCS Projects

**Vehicle Occupant Detection**

- User's Guide
- PC GUI
- Release Notes
- CCS Project - MSS 16xx
- CCS Project - DSS 16xx
- CCS Project - MSS 18xx
- CCS Project - DSS 18xx
- CCS Project - MSS 68xx
- CCS Project - DSS 68xx

HTML User's Guide  
MATLAB GUI  
Vehicle Occupant Detection Release Notes  
Vehicle Occupant Detection MSS 16xx  
Vehicle Occupant Detection DSS 16xx  
Vehicle Occupant Detection MSS 18xx  
Vehicle Occupant Detection DSS 18xx  
Vehicle Occupant Detection MSS 68xx  
Vehicle Occupant Detection DSS 68xx

**Vehicle Occupancy Detection User's Guide**

### Overview

This lab demonstrates the use of TI mmWave sensors to detect people and animals in pre-defined zones of coverage. Using TI 60GHz AWR6843, and 77GHz AWR1843 and AWR1642 mmwave devices, algorithms run onboard the single-chip device to create an Range-Azimuth heatmap, then extract features and detections from the heatmap. Chirp configurations are selected to detect slight movements (like breathing) with a high degree of accuracy. Two use cases are supported - Vehicle Occupancy Detection (VOD) and Child Presence Detection (CPD).

Overview  
Quickstart  
Developer's Guide  
Need More Help?

## Key Performance Specifications

Parameter	Value
Max range	3.0 m
Max velocity	2.78 m/s
Range resolution	5.32cm
Velocity resolution	0.0154 m/s
Field of View	120° Horizontal
Bandwidth	2.8218 GHz

- mmwave\_automotive\_toolbox\_3\_1\_x
  - Available in TI Resource Explorer
  - (within CCS, or <http://dev.ti.com/tirex/explore>)
- mmWave SDK
  - Installer here: [www.ti.com/tool/mmwave-sdk](http://www.ti.com/tool/mmwave-sdk)

# Signal Processing Chain: Overhead Block Diagram

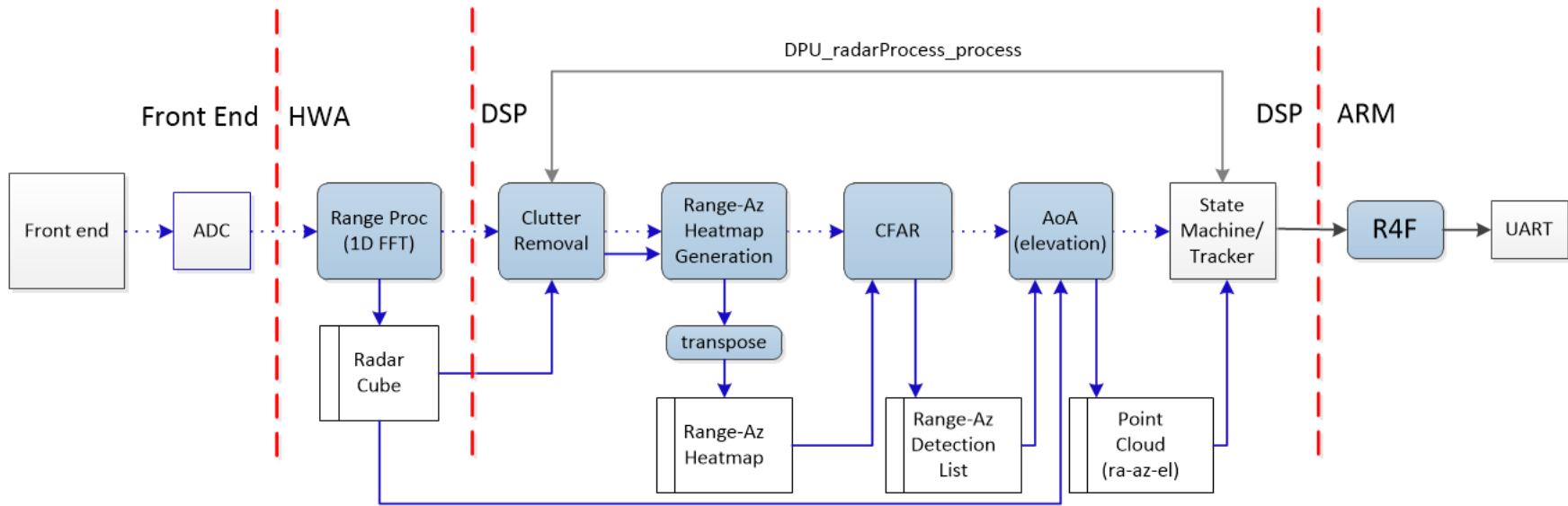

- Range/Chirp processing chain is performed on the Hardware Accelerator (HWA).
- Frame rate signal processing implemented on DSP (C674x) and outputs point cloud and zone decisions.
- R4F (MSS ARM) processor transfers outputs from shared memory to UART.



# Signal Processing Chain: Coordinate Transform

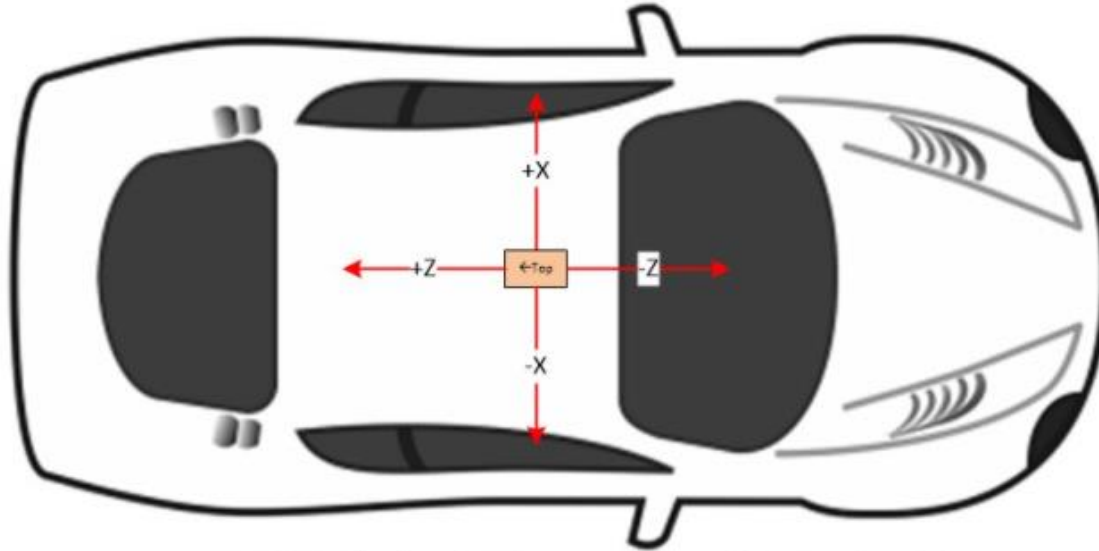

$Y = 0$  is the floorboard,  $+Y$  increases to the roof (antenna location)

- Typically, a vertical mounting yields  $Y$  as positive range,  $Z$  as elevation ( $-$ values below sensor).
- With a horizontal mounting,  $Y$  becomes elevation (zero is the floor), and  $Z$  is range ( $+$ values to the rear,  $-$ values to the front).  $X$  remains azimuth angle.

# Range-Azimuth Heatmap Processing

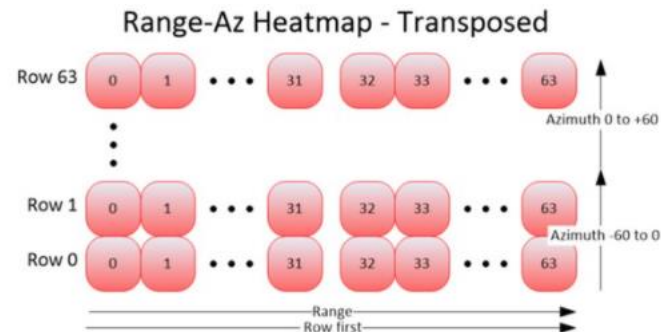
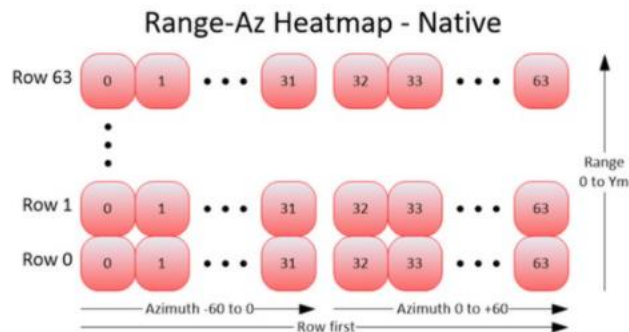
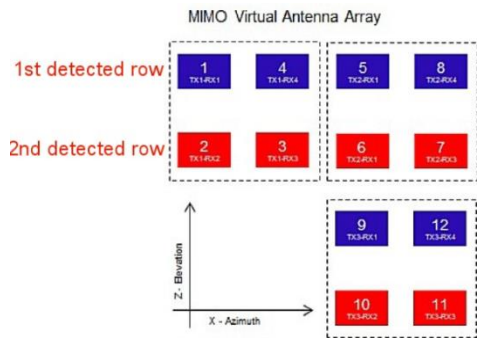

- Algorithm for the Ra-Az heatmap are the same as described for the Front Mount VOD demo, with these exceptions:
  - Two rows of azimuth oriented virtual antennas are located (if two exist), and MVDR is calculated on each row. The values in each row are squared and summed to form the final heatmap row. This is to improve SNR.
  - The heatmap row is natively per each range bin. This is transposed so that each row contains all range values per azimuth bin.

# Dual-pass CFAR Processing

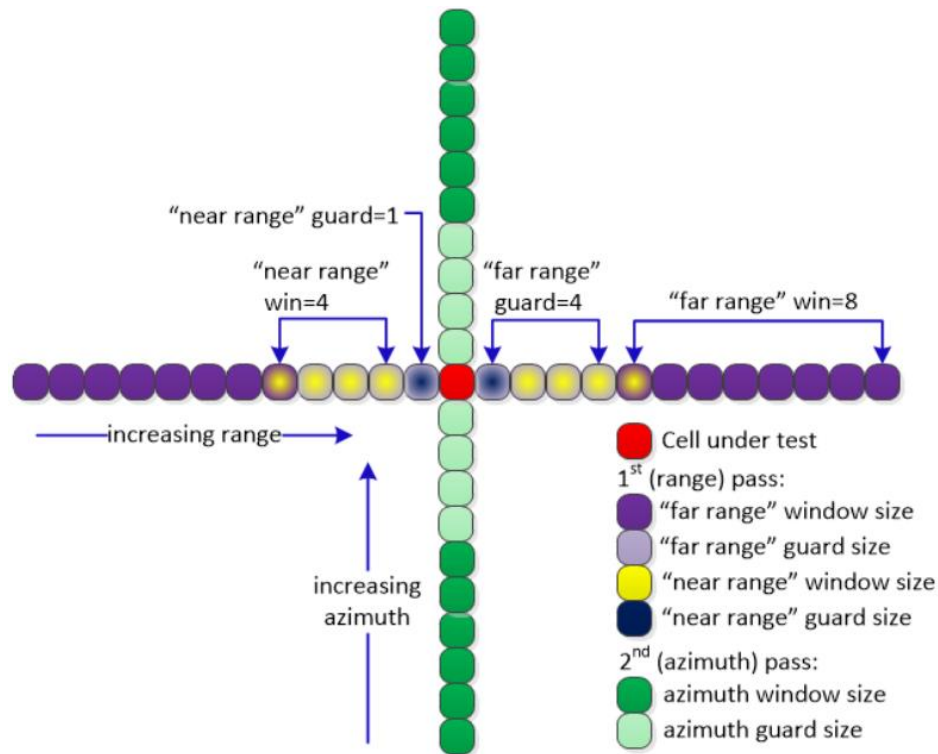

- The CFAR variant used is CASO (Cell Averaging Smaller Of), with a few improvements:
  - In the first (range) pass, two window averages are created on both sides of the cell under test:
    - Near Range, mostly in the guard area of the Far windows
    - Far Range
  - This gives a total of 4 averages. The smallest of these is found and thresholded, and compared to the peak.
- These initial detections (in range) are kept for the second pass search in the azimuth dimension.
- Multiple peaks may be found in both range and azimuth.

# Zone Definition and Assignment

3D Zone Definition (side view)

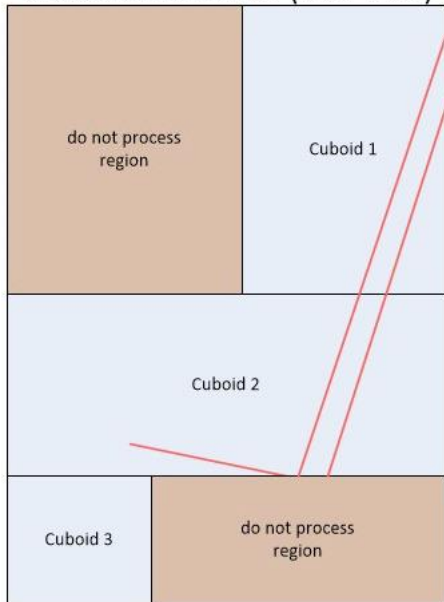

- Following CFAR, standard AoA (Angle of Arrival) processing is performed to estimate elevation for each range-azimuth CFAR output, yielding a point cloud with range, azimuth and elevation coordinates.
- To estimate the spaces where we look for occupants, we may define one, two or three cuboid volumes in our coordinate space, to represent the head-chest, lap, and leg-foot areas of the zone. **Zone assignment occurs when a point cloud detection resides within at least one of the zone's cuboids.**
- Detections not matching any zone are ignored.
- Cuboids may overlap or be disjoint.
- Zones should not overlap, and will perform better with some amount of space between them.
- Some zones, such as intruder spaces and cargo areas can be represented with a single cuboid.

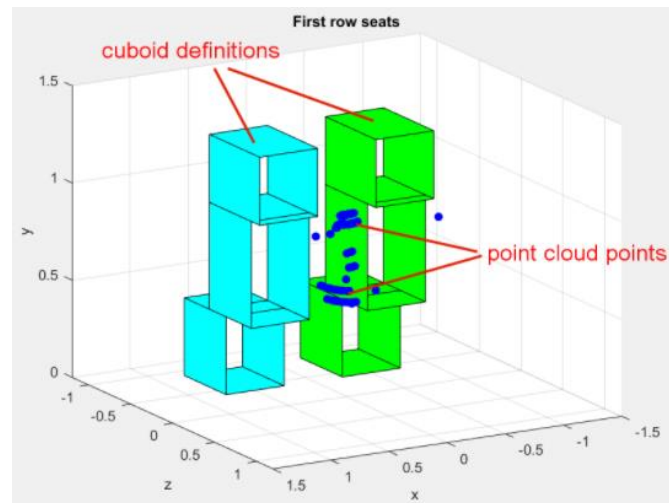

# Zone State Machine Processing

## Zone State Machine

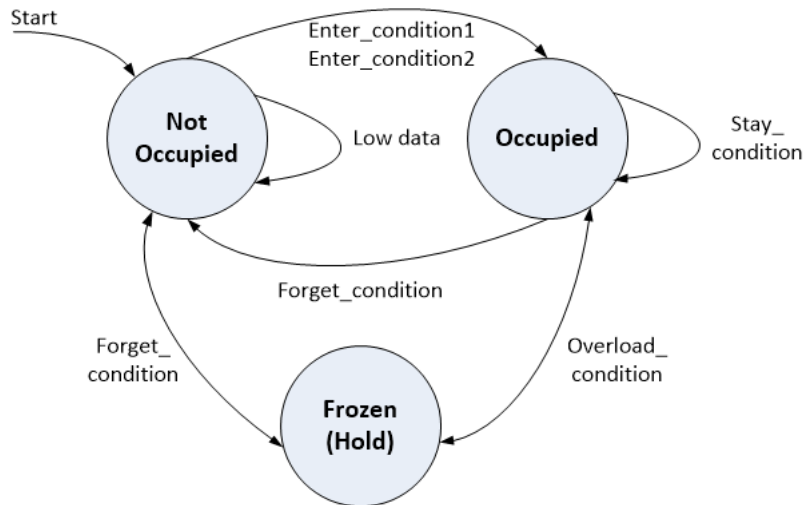

- The Zone State Machine is the processing that examines the detections within each zone and makes yes/no occupancy decisions each frame.
- Entry conditions:
  - small number of detections with a high average SNR, \*or\*
  - larger number of detections with smaller average SNR.
- Stay condition:
  - num detections with thresholded SNR
- Forget condition:
  - exceeds number of frames failing the Stay condition
- Overload condition:
  - High energy level (vehicle entry, exit, or someone changing seats). This causes all zone states to be frozen until the overload subsides.
- All parameters are configurable via CLI interface.
- This is not a perfect science, and the state machine is evolving over time. We encourage customers to build upon our rules to fine-tune the processing to fit their needs.

# GUI Display

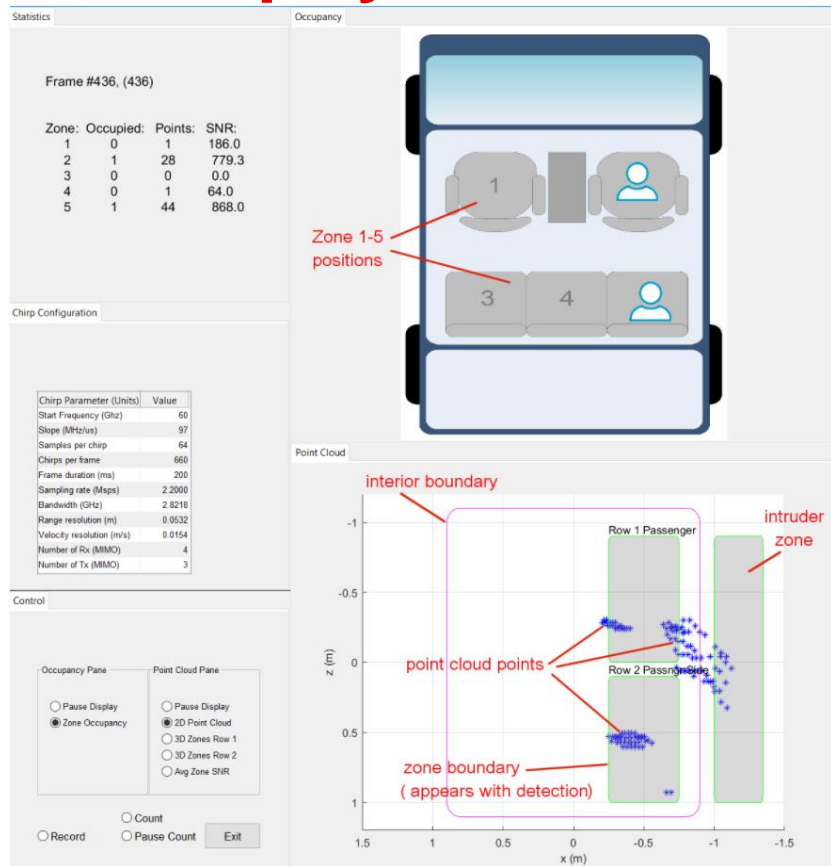

- The Matlab GUI presents the output in 5 sub-windows:
  - **Statistics:** Shows frame number, list of zones with number of points and avg SNR.
    - Will show detection counts when enabled.
  - **Chirp Configuration:** Shows the CLI chirp configuration transformed into readable format.
  - **Control:** Button controls
  - **Occupancy:** A fixed display showing one to five zones mapped in a vehicle space.
  - **Point Cloud:** Several displays that show frame by frame detections within mapped zone boundaries.

# Learn more about TI mmWave Sensors

- Learn more about AWRxxxx devices, please visit the product pages
  - AWR6843: <http://www.ti.com/product/AWR6843>
- Get started evaluating the platform with xWR1x EVMs, purchase EVM at
  - AWR6843 EVM: <http://www.ti.com/tool/AWR684ISK>
  - IWR6843AOPEVM: <https://www.ti.com/tool/IWR6843AOPEVM>
- VOD Video: <https://training.ti.com/vehicle-occupant-detection-using-mmwave-sensors>
- VOD Blog: [http://e2e.ti.com/blogs\\_/b/behind\\_the\\_wheel/archive/2018/04/30/detecting-vehicle-occupancy-with-mmwave-sensors](http://e2e.ti.com/blogs_/b/behind_the_wheel/archive/2018/04/30/detecting-vehicle-occupancy-with-mmwave-sensors)
- Automotive toolbox on TIREX:  
<http://dev.ti.com/tirex/#/DevTool/AWR1642%20Automotive%20EVM/?link=Software%2FmmWave%20Sensors%2FAutomotive%20Toolbox>
- Ask questions on TI's E2E forum @ <http://e2e.ti.com>



**©2020 Texas Instruments Incorporated. All rights reserved.**

The material is provided strictly "as-is" for informational purposes only and without any warranty.  
Use of this material is subject to TI's **Terms of Use**, viewable at [TI.com](https://www.ti.com)



## IMPORTANT NOTICE AND DISCLAIMER

TI PROVIDES TECHNICAL AND RELIABILITY DATA (INCLUDING DATASHEETS), DESIGN RESOURCES (INCLUDING REFERENCE DESIGNS), APPLICATION OR OTHER DESIGN ADVICE, WEB TOOLS, SAFETY INFORMATION, AND OTHER RESOURCES "AS IS" AND WITH ALL FAULTS, AND DISCLAIMS ALL WARRANTIES, EXPRESS AND IMPLIED, INCLUDING WITHOUT LIMITATION ANY IMPLIED WARRANTIES OF MERCHANTABILITY, FITNESS FOR A PARTICULAR PURPOSE OR NON-INFRINGEMENT OF THIRD PARTY INTELLECTUAL PROPERTY RIGHTS.

These resources are intended for skilled developers designing with TI products. You are solely responsible for (1) selecting the appropriate TI products for your application, (2) designing, validating and testing your application, and (3) ensuring your application meets applicable standards, and any other safety, security, or other requirements. These resources are subject to change without notice. TI grants you permission to use these resources only for development of an application that uses the TI products described in the resource. Other reproduction and display of these resources is prohibited. No license is granted to any other TI intellectual property right or to any third party intellectual property right. TI disclaims responsibility for, and you will fully indemnify TI and its representatives against, any claims, damages, costs, losses, and liabilities arising out of your use of these resources.

TI's products are provided subject to TI's Terms of Sale ([www.ti.com/legal/termsofsale.html](http://www.ti.com/legal/termsofsale.html)) or other applicable terms available either on [ti.com](http://ti.com) or provided in conjunction with such TI products. TI's provision of these resources does not expand or otherwise alter TI's applicable warranties or warranty disclaimers for TI products.

Mailing Address: Texas Instruments, Post Office Box 655303, Dallas, Texas 75265  
Copyright © 2020, Texas Instruments Incorporated