



Table of Contents

1 Overview.....	2
2 Functional Safety Failure In Time (FIT) Rates.....	3
3 Failure Mode Distribution (FMD).....	4
4 Pin Failure Mode Analysis (Pin FMA).....	5

Trademarks

All trademarks are the property of their respective owners.

1 Overview

This document contains information for the TPS6287x (WQFN package) to aid in a functional safety system design. Information provided are:

- Functional Safety Failure In Time (FIT) rates of the semiconductor component estimated by the application of industry reliability standards
- Component failure modes and their distribution (FMD) based on the primary function of the device
- Pin failure mode analysis (Pin FMA)

Figure 1-1 shows the device functional block diagram for reference.

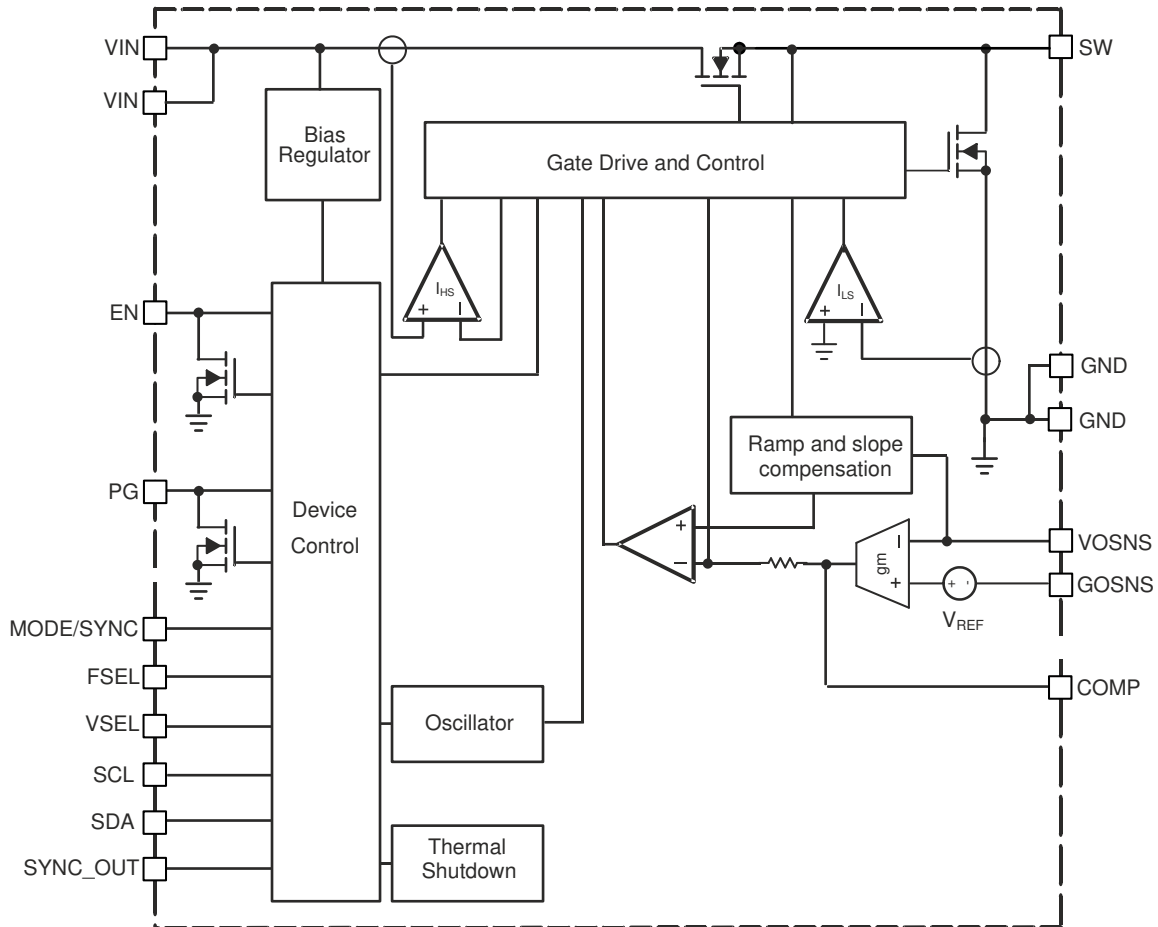

Figure 1-1. Functional Block Diagram

The TPS6287x was developed using a quality-managed development process, but were not developed in accordance with the IEC 61508 or ISO 26262 standards.

2 Functional Safety Failure In Time (FIT) Rates

This section provides Functional Safety Failure In Time (FIT) rates for the TPS6287x based on two different industry-wide used reliability standards:

- [Table 2-1](#) provides FIT rates based on IEC TR 62380 / ISO 26262 part 11
- [Table 2-2](#) provides FIT rates based on the Siemens Norm SN 29500-2

Table 2-1. Component Failure Rates per IEC TR 62380 / ISO 26262 Part 11

FIT IEC TR 62380 / ISO 26262	FIT (Failures Per 10 ⁹ Hours)
Total Component FIT Rate	12
Die FIT Rate	6
Package FIT Rate	6

The failure rate and mission profile information in [Table 2-1](#) comes from the Reliability data handbook IEC TR 62380 / ISO 26262 part 11:

- Mission Profile: Motor Control from Table 11
- Power dissipation: 1144 mW
- Climate type: World-wide Table 8
- Package factor (lambda 3): Table 17b
- Substrate Material: FR4
- EOS FIT rate assumed: 0 FIT

Table 2-2. Component Failure Rates per Siemens Norm SN 29500-2

Table	Category	Reference FIT Rate	Reference Virtual T _J
5	CMOS, BICMOS Digital, analog / mixed	25 FIT	55°C

The Reference FIT Rate and Reference Virtual T_J (junction temperature) in [Table 2-2](#) come from the Siemens Norm SN 29500-2 tables 1 through 5. Failure rates under operating conditions are calculated from the reference failure rate and virtual junction temperature using conversion information in SN 29500-2 section 4.

3 Failure Mode Distribution (FMD)

The failure mode distribution estimation for the TPS6287x in [Table 3-1](#) comes from the combination of common failure modes listed in standards such as IEC 61508 and ISO 26262, the ratio of sub-circuit function size and complexity and from best engineering judgment.

The failure modes listed in this section reflect random failure events and do not include failures due to misuse or overstress.

Table 3-1. Die Failure Modes and Distribution

Die Failure Modes	Failure Mode Distribution (%)
SW no output	20%
SW output not in specification – voltage or timing	15%
SW power HS or LS FET stuck on	35%
EN or PG false trip or fails to trip	10%
Switching frequency or output voltage range not in spec	10%
No device communication	10%

The FMD in [Table 3-1](#) excludes short circuit faults across the isolation barrier. Faults for short circuit across the isolation barrier can be excluded according to ISO 61800-5-2:2016 if the following requirements are fulfilled:

1. The signal isolation component is OVC III according to IEC 61800-5-1. If a SELV/PELV power supply is used, pollution degree 2/OVC II applies. All requirements of IEC 61800-5-1:2007, 4.3.6 apply.
2. Measures are taken to ensure that an internal failure of the signal isolation component cannot result in excessive temperature of its insulating material.

Creepage and clearance requirements should be applied according to the specific equipment isolation standards of an application. Care should be taken to maintain the creepage and clearance distance of a board design to ensure that the mounting pads of the isolator on the printed-circuit board do not reduce this distance.

4 Pin Failure Mode Analysis (Pin FMA)

This section provides a Failure Mode Analysis (FMA) for the pins of the TPS6287x. The failure modes covered in this document include the typical pin-by-pin failure scenarios:

- Pin short-circuited to Ground (see [Table 4-2](#))
- Pin open-circuited (see [Table 4-3](#))
- Pin short-circuited to an adjacent pin (see [Table 4-4](#))
- Pin short-circuited to VIN (see [Table 4-5](#))

[Table 4-2](#) through [Table 4-5](#) also indicate how these pin conditions can affect the device as per the failure effects classification in [Table 4-1](#).

Table 4-1. TI Classification of Failure Effects

Class	Failure Effects
A	Potential device damage that affects functionality
B	No device damage, but loss of functionality
C	No device damage, but performance degradation
D	No device damage, no impact to functionality or performance

[Figure 4-1](#) shows the TPS6287x pin diagram. For a detailed description of the device pins please refer to the *Pin Configuration and Functions* section in the TPS6287x data sheet.

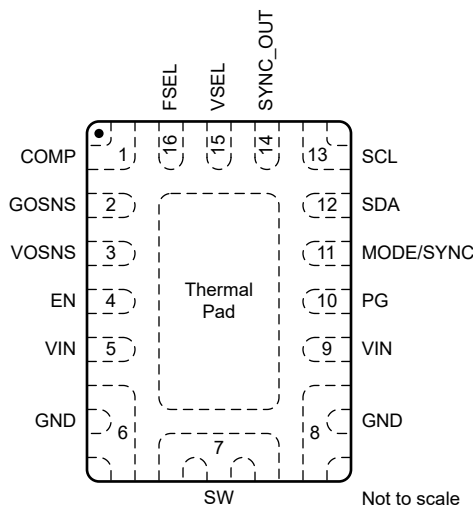

Figure 4-1. Pin Diagram

Following are the assumptions of use and the device configuration assumed for the pin FMA in this section:

- Assumption the device is running in the typical application, please refer to the 'Simplified Schematics' on the first page in the [TPS6287x 2.7-V to 6-V Input, 6-A/9-A/12-A/15-A, Stackable, Synchronous Step-Down Converters with Fast Transient Response](#) data sheet.

Table 4-2. Pin FMA for Device Pins Short-Circuited to Ground

Pin Name	Pin No.	Description of Potential Failure Effect(s)	Failure Effect Class
COMP	1	The device does not power up and there is no output voltage.	B
GOSNS	2	Normal operation, but output voltage accuracy gets worse	C
VOSNS	3	Maximum duty cycle operation and no regulated output voltage. Output voltage follows the input voltage.	B
EN	4	The device is disabled. Normal operation	C
VIN	5	The device does not power up and there is no output voltage.	B
GND	6	Normal operation	D
SW	7	Potential device damage	A
GND	8	Normal operation	D
VIN	9	The device does not power up and there is no output voltage.	B
PG	10	Normal operation and loss of PG indication	B
MODE/SYNC	11	Normal operation. Power save mode is enabled.	C
SDA	12	Normal operation and no I ² C communication	B
SCL	13	Normal operation and no I ² C communication	B
SYNC_OUT	14	Potential device damage	A
VSEL	15	Normal operation. Defines start-up voltage	C
FSEL	16	Normal operation. Defines switching frequency	C

Table 4-3. Pin FMA for Device Pins Open-Circuited

Pin Name	Pin No.	Description of Potential Failure Effect(s)	Failure Effect Class
COMP	1	No loop compensation and can cause the output voltage to oscillate. Oscillation frequency cannot be predicted.	B
GOSNS	2	No output voltage regulation and can cause the output voltage to oscillate. Oscillation frequency cannot be predicted.	B
VOSNS	3	No output voltage regulation and can cause the output voltage to oscillate. Oscillation frequency cannot be predicted.	B
EN	4	Undetermined device operation. The device can power up and operate normal. Stays turned off	B
VIN	5	Normal operation. Pin 9 is still connected.	C
GND	6	Normal operation. Pin 8 and the exposed thermal pad are still connected.	C
SW	7	No output voltage	B
GND	8	Normal operation. Pin 6 and the exposed thermal pad are still connected.	C
VIN	9	Normal operation. Pin 5 is still connected.	C
PG	10	Normal operation and loss of PG indication	B
MODE/SYNC	11	Normal operation. Operation mode is undefined.	B
SDA	12	Normal operation and no I ² C communication	B
SCL	13	Normal operation and no I ² C communication	B
SYNC_OUT	14	Normal operation	D
VSEL	15	Normal operation. Start-up voltage is undefined.	B
FSEL	16	Normal operation. Switching frequency is undefined.	B

Table 4-4. Pin FMA for Device Pins Short-Circuited to Adjacent Pin

Pin Name	Pin No.	Shorted to	Description of Potential Failure Effect(s)	Failure Effect Class
COMP	1	2	The device does not power up and there is no output voltage.	B
GOSNS	2	3	Maximum duty cycle operation and no regulated output voltage. Output voltage follows the input voltage.	B
VOSNS	3	4	The device does not power up or there is potential device damage.	A
EN	4	5	Potential device damage	A
VIN	5	6	The device does not power up and there is no output voltage.	B
GND	6	7	Potential device damage	A
SW	7	8	Potential device damage	A
GND	8	9	The device does not power up and there is no output voltage.	B
VIN	9	10	Potential device damage	A
PG	10	11	Potential device damage if MODE/SYNC is tied high. Loss of PG indication	A
MODE/SYNC	11	12	Potential device damage if MODE/SYNC is tied high. No I ² C communication	A
SDA	12	13	Normal operation and no I ² C communication	B
SCL	13	14	Potential device damage	A
SYNC_OUT	14	15	Potential device damage if VSEL is tied high or low	A
VSEL	15	16	Normal operation. Defines start-up voltage and switching frequency	B
FSEL	16	1	No output voltage regulation and can cause output voltage oscillating. Oscillation frequency cannot be predicted.	B

Table 4-5. Pin FMA for Device Pins Short-Circuited to VIN

Pin Name	Pin No.	Description of Potential Failure Effect(s)	Failure Effect Class
COMP	1	Potential device damage	A
GOSNS	2	Potential device damage	A
VOSNS	3	The device does not start up. Output voltage stays low or potential device damage.	A
EN	4	Potential device damage	A
VIN	5	Normal operation	D
GND	6	The device does not power up and there is no output voltage.	B
SW	7	Potential device damage	A
GND	8	The device does not power up and there is no output voltage.	B
VIN	9	Normal operation	D
PG	10	Potential device damage	A
MODE/SYNC	11	Normal operation and forced PWM operation	C
SDA	12	Potential device damage	A
SCL	13	Potential device damage	A
SYNC_OUT	14	Potential device damage	A
VSEL	15	Normal operation. Defines start-up voltage	C
FSEL	16	Normal operation. Defines switching frequency	C

IMPORTANT NOTICE AND DISCLAIMER

TI PROVIDES TECHNICAL AND RELIABILITY DATA (INCLUDING DATA SHEETS), DESIGN RESOURCES (INCLUDING REFERENCE DESIGNS), APPLICATION OR OTHER DESIGN ADVICE, WEB TOOLS, SAFETY INFORMATION, AND OTHER RESOURCES "AS IS" AND WITH ALL FAULTS, AND DISCLAIMS ALL WARRANTIES, EXPRESS AND IMPLIED, INCLUDING WITHOUT LIMITATION ANY IMPLIED WARRANTIES OF MERCHANTABILITY, FITNESS FOR A PARTICULAR PURPOSE OR NON-INFRINGEMENT OF THIRD PARTY INTELLECTUAL PROPERTY RIGHTS.

These resources are intended for skilled developers designing with TI products. You are solely responsible for (1) selecting the appropriate TI products for your application, (2) designing, validating and testing your application, and (3) ensuring your application meets applicable standards, and any other safety, security, regulatory or other requirements.

These resources are subject to change without notice. TI grants you permission to use these resources only for development of an application that uses the TI products described in the resource. Other reproduction and display of these resources is prohibited. No license is granted to any other TI intellectual property right or to any third party intellectual property right. TI disclaims responsibility for, and you will fully indemnify TI and its representatives against, any claims, damages, costs, losses, and liabilities arising out of your use of these resources.

TI's products are provided subject to [TI's Terms of Sale](#) or other applicable terms available either on [ti.com](https://www.ti.com) or provided in conjunction with such TI products. TI's provision of these resources does not expand or otherwise alter TI's applicable warranties or warranty disclaimers for TI products.

TI objects to and rejects any additional or different terms you may have proposed.

Mailing Address: Texas Instruments, Post Office Box 655303, Dallas, Texas 75265
Copyright © 2024, Texas Instruments Incorporated