

DRV5013 Digital-Latch Hall Effect Sensor

1 Features

- Digital bipolar-latch Hall sensor
- Superior temperature stability
 - $B_{OP} \pm 10\%$ over temperature
- Multiple sensitivity options (B_{OP} / B_{RP})
 - $\pm 1.3\text{mT}$ (FA, see [Device Nomenclature](#))
 - $\pm 2.7\text{mT}$ (AD, ND, see [Device Nomenclature](#))
 - $\pm 6\text{mT}$ (AG, see [Device Nomenclature](#))
 - $\pm 12\text{mT}$ (BC, see [Device Nomenclature](#))
- Supports a wide voltage range
 - 2.5V to 38V
 - No external regulator required
- Wide operating temperature range
 - $T_A = -40$ to $+125^\circ\text{C}$ (Q, see [Device Nomenclature](#))
 - $T_A = -40$ to $+150^\circ\text{C}$ (E, see [Device Nomenclature](#))
- Open-drain output (30mA sink)
- Fast $35\mu\text{s}$ power-on time
- Small package and footprint
 - Surface mount 3-pin SOT-23 (DBZ)
 - $2.92\text{mm} \times 2.37\text{mm}$
 - Through-hole 3-pin TO-92 (LPG, LPE)
 - $4\text{mm} \times 3.15\text{mm}$
- **Protection features:**
 - Reverse supply protection (up to -22V)
 - Supports up to 40V load dump
 - Output short-circuit protection
 - Output current limitation

2 Applications

- Power tools
- Flow meters
- Valve and solenoid status
- Brushless dc motors
- Proximity sensing
- Tachometers

3 Description

The DRV5013 device is a chopper-stabilized Hall effect sensor that offers a magnetic sensing solution with superior sensitivity stability over temperature and integrated protection features.

The magnetic field is indicated through a digital bipolar latch output. The IC has an open-drain output stage with 30-mA current sink capability. A wide operating voltage range from 2.5 V to 38 V with reverse polarity protection up to -22 V makes the device suitable for a wide range of industrial applications.

Internal protection functions are provided for reverse supply conditions, load dump, and output short circuit or overcurrent.

Package Information⁽¹⁾

PART NUMBER	PACKAGE	BODY SIZE (NOM)
DRV5013	SOT-23 (3)	2.92 mm × 1.30 mm
	TO-92 (3)	4.00 mm × 3.15 mm

- (1) For all available packages, see the package option addendum at the end of the data sheet.

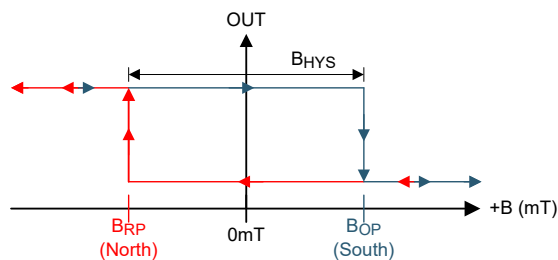

Output State (FA, AD, AG, BC Versions)

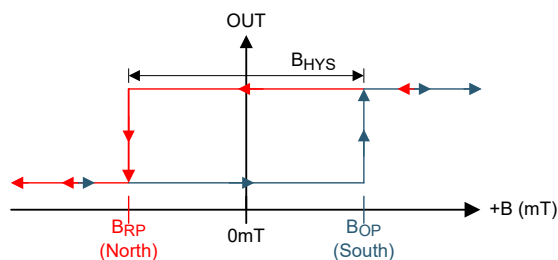

Inverted Output State (ND Version)

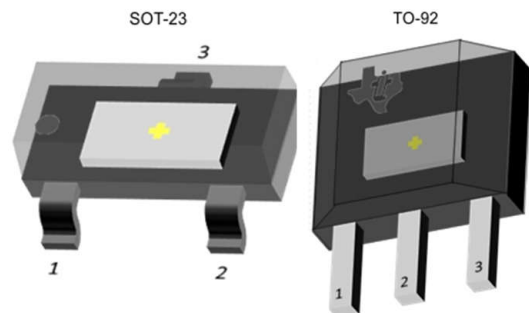

Device Packages



Table of Contents

1 Features	1	6.4 Device Functional Modes.....	14
2 Applications	1	7 Application and Implementation	15
3 Description	1	7.1 Application Information.....	15
4 Pin Configuration and Functions	3	7.2 Typical Applications.....	15
5 Specifications	4	7.3 Power Supply Recommendations.....	18
5.1 Absolute Maximum Ratings.....	4	7.4 Layout.....	18
5.2 ESD Ratings.....	4	8 Device and Documentation Support	19
5.3 Recommended Operating Conditions.....	4	8.1 Device Support.....	19
5.4 Thermal Information.....	4	8.2 Receiving Notification of Documentation Updates....	19
5.5 Electrical Characteristics.....	5	8.3 Support Resources.....	20
5.6 Switching Characteristics.....	5	8.4 Trademarks.....	20
5.7 Magnetic Characteristics.....	5	8.5 Electrostatic Discharge Caution.....	20
5.8 Typical Characteristics.....	7	8.6 Glossary.....	20
6 Detailed Description	9	9 Revision History	20
6.1 Overview.....	9	10 Mechanical, Packaging, and Orderable Information	22
6.2 Functional Block Diagram.....	9		
6.3 Feature Description.....	10		

4 Pin Configuration and Functions

For additional configuration information, see [Device Markings](#) and [Mechanical, Packaging, and Orderable Information](#).

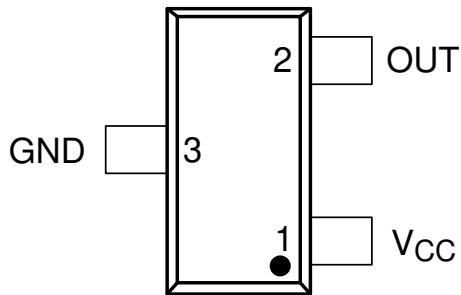

Figure 4-1. DBZ Package 3-Pin SOT-23 Top View

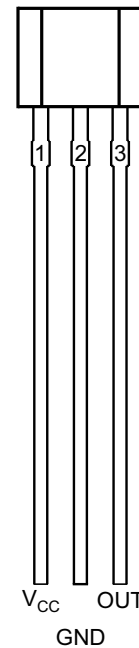

Figure 4-2. LPG and LPE Packages 3-Pin TO-92 Top View

Table 4-1. Pin Functions

NAME	PIN		TYPE	DESCRIPTION
	DBZ	LPG, LPE		
GND	3	2	Ground	Ground pin
OUT	2	3	Output	Hall sensor open-drain output. The open drain requires a resistor pullup.
V _{CC}	1	1	Power	2.5 V to 38 V power supply. Bypass this pin to the GND pin with a 0.01- μ F (minimum) ceramic capacitor rated for V _{CC} .

5 Specifications

5.1 Absolute Maximum Ratings

over operating free-air temperature range (unless otherwise noted) ⁽¹⁾

		MIN	MAX	UNIT
Power supply voltage	V_{CC}	-22 ⁽²⁾	40	V
	Voltage ramp rate (V_{CC}), $V_{CC} < 5V$	Unlimited		V/ μ s
	Voltage ramp rate (V_{CC}), $V_{CC} > 5V$	0	2	
Output pin voltage		-0.5	40	V
Output pin reverse current during reverse supply condition		0	100	mA
Magnetic flux density, B_{MAX}		Unlimited		
Operating junction temperature, T_J	Q, see Figure 8-1	-40	150	°C
	E, see Figure 8-1	-40	175	
Storage temperature, T_{stg}		-65	150	°C

- (1) Operation outside the *Absolute Maximum Ratings* may cause permanent device damage. *Absolute Maximum Ratings* do not imply functional operation of the device at these or any other conditions beyond those listed under *Recommended Operating Conditions*. If used outside the *Recommended Operating Conditions* but within the *Absolute Maximum Ratings*, the device may not be fully functional, and this may affect device reliability, functionality, performance, and shorten the device lifetime.
- (2) Specified by design. Only tested to -20 V.

5.2 ESD Ratings

			VALUE	UNIT
$V_{(ESD)}$	Electrostatic discharge	Human body model (HBM), per ANSI/ESDA/JEDEC JS-001, all pins ⁽¹⁾	±2500	V
		Charged device model (CDM), per JEDEC specification JESD22-C101, all pins ⁽²⁾	±500	

- (1) JEDEC document JEP155 states that 500-V HBM allows safe manufacturing with a standard ESD control process.
- (2) JEDEC document JEP157 states that 250-V CDM allows safe manufacturing with a standard ESD control process.

5.3 Recommended Operating Conditions

over operating free-air temperature range (unless otherwise noted)

		MIN	MAX	UNIT	
V_{CC}	Power supply voltage	2.5	38	V	
V_O	Output pin voltage (OUT)	0	38	V	
I_{SINK}	Output pin current sink (OUT) ⁽¹⁾	0	30	mA	
T_A	Operating ambient temperature	Q, see Figure 8-1	-40	125	°C
		E, see Figure 8-1	-40	150	

- (1) Power dissipation and thermal limits must be observed.

5.4 Thermal Information

THERMAL METRIC ⁽¹⁾		DRV5013		UNIT
		DBZ (SOT-23)	LPG, LPE (TO-92)	
		3 PINS	3 PINS	
$R_{\theta JA}$	Junction-to-ambient thermal resistance	333.2	180	°C/W
$R_{\theta JC(top)}$	Junction-to-case (top) thermal resistance	99.9	98.6	°C/W
$R_{\theta JB}$	Junction-to-board thermal resistance	66.9	154.9	°C/W
Ψ_{JT}	Junction-to-top characterization parameter	4.9	40	°C/W

THERMAL METRIC ⁽¹⁾		DRV5013		UNIT
		DBZ (SOT-23)	LPG, LPE (TO-92)	
		3 PINS	3 PINS	
Ψ_{JB}	Junction-to-board characterization parameter	65.2	154.9	°C/W

(1) For more information about traditional and new thermal metrics, see the [Semiconductor and IC Package Thermal Metrics](#) application report.

5.5 Electrical Characteristics

over operating free-air temperature range (unless otherwise noted)

PARAMETER		TEST CONDITIONS	MIN	TYP	MAX	UNIT
POWER SUPPLIES (V_{CC})						
V _{CC}	V _{CC} operating voltage		2.5		38	V
I _{CC}	Operating supply current	ND Version V _{CC} = 2.5V to 38V, T _A = 25°C		1.5		mA
		ND Version V _{CC} = 2.5V to 38V, T _A = T _{A,MAX} ⁽¹⁾		1.5	3.2	
		AD, AG, BC, FA Versions V _{CC} = 2.5V to 38V, T _A = 25°C		2.7		
		AD, AG, BC, FA Versions V _{CC} = 2.5V to 38V, T _A = T _{A,MAX} ⁽¹⁾		3	3.5	
t _{on}	Power-on time	AD, AG, BC, ND versions		35	50	µs
		FA version		35	70	
OPEN DRAIN OUTPUT (OUT)						
r _{DS(on)}	FET on-resistance	V _{CC} = 3.3V, I _O = 10mA, T _A = 25°C		22		Ω
		V _{CC} = 3.3V, I _O = 10mA, T _A = T _{A,MAX} ⁽¹⁾		36	50	
I _{lkg(off)}	Off-state leakage current	Output Hi-Z			1	µA
PROTECTION CIRCUITS						
V _{CCR}	Reverse supply voltage		-22			V
I _{OC}	Overcurrent protection level	OUT shorted V _{CC}	15	30	45	mA

(1) T_{A,MAX} is 125°C for Q devices and 150°C for E devices (see [Figure 8-1](#)).

5.6 Switching Characteristics

over operating free-air temperature range (unless otherwise noted)

PARAMETER		TEST CONDITIONS	MIN	TYP	MAX	UNIT
OPEN-DRAIN OUTPUT (OUT)						
t _d	Output delay time	B = B _{RP} – 10mT to B _{OP} + 10mT in 1µs		13	25	µs
t _r	Output rise time (10% to 90%)	R1 = 1kΩ, C _O = 50pF, V _{CC} = 3.3V		200		ns
t _f	Output fall time (90% to 10%)	R1 = 1kΩ, C _O = 50pF, V _{CC} = 3.3V		31		ns

5.7 Magnetic Characteristics

over operating free-air temperature range (unless otherwise noted)

PARAMETER		TEST CONDITIONS	MIN	TYP	MAX	UNIT ⁽¹⁾
f _{BW}	Bandwidth ⁽²⁾		20	30		kHz
DRV5013FA: ±1.3 mT						
B _{OP}	Operate point; see Figure 6-2	T _A = -40°C to T _{A,MAX} ⁽³⁾	-0.6	1.3	3.4	mT
B _{RP}	Release point; see Figure 6-2		-3.4	-1.3	0.6	
B _{hys}	Hysteresis; B _{hys} = (B _{OP} – B _{RP})		1.2	2.6		
B _O	Magnetic offset; B _O = (B _{OP} + B _{RP}) / 2		-1.5	0	1.5	

DRV5013

SLIS150M – MARCH 2014 – REVISED JUNE 2024

over operating free-air temperature range (unless otherwise noted)

PARAMETER		TEST CONDITIONS	MIN	TYP	MAX	UNIT ⁽¹⁾
DRV5013AD: ±2.7 mT						
B _{OP}	Operate point; see Figure 6-2	T _A = -40°C to T _{A,MAX} ⁽³⁾	1	2.7	5	mT
B _{RP}	Release point; see Figure 6-2		-5	-2.7	-1	
B _{hys}	Hysteresis; B _{hys} = (B _{OP} - B _{RP})			5.4		
B _O	Magnetic offset; B _O = (B _{OP} + B _{RP}) / 2		-1.5	0	1.5	
DRV5013ND: ±2.7 mT						
B _{OP}	Operate point; see Figure 6-3	T _A = 25°C	2	2.7	3.3	mT
		T _A = -40°C to T _{A,MAX} ⁽³⁾	1.5	2.7	3.6	
B _{RP}	Release point; see Figure 6-3	T _A = 25°C	-3.3	-2.7	-2	
		T _A = -40°C to T _{A,MAX} ⁽³⁾	-3.6	-2.7	-1.5	
B _{hys}	Hysteresis; B _{hys} = (B _{OP} - B _{RP})	T _A = 25°C	4.3	5.4		
		T _A = -40°C to T _{A,MAX} ⁽³⁾	3	5.4		
B _O	Magnetic offset; B _O = (B _{OP} + B _{RP}) / 2	T _A = 25°C	-0.5	0	0.5	
		T _A = -40°C to T _{A,MAX} ⁽³⁾	-1	0	1	
DRV5013AG: ±6 mT						
B _{OP}	Operate point; see Figure 6-2	T _A = -40°C to T _{A,MAX} ⁽³⁾	3	6	9	mT
B _{RP}	Release point; see Figure 6-2		-9	-6	-3	
B _{hys}	Hysteresis; B _{hys} = (B _{OP} - B _{RP})			12		
B _O	Magnetic offset; B _O = (B _{OP} + B _{RP}) / 2		-1.5	0	1.5	
DRV5013BC: ±12 mT						
B _{OP}	Operate point; see Figure 6-2	T _A = -40°C to T _{A,MAX} ⁽³⁾	6	12	18	mT
B _{RP}	Release point; see Figure 6-2		-18	-12	-6	
B _{hys}	Hysteresis; B _{hys} = (B _{OP} - B _{RP})			24		
B _O	Magnetic offset; B _O = (B _{OP} + B _{RP}) / 2		-1.5	0	1.5	

(1) 1 mT = 10 Gauss.

(2) Bandwidth describes the fastest changing magnetic field that can be detected and translated to the output.

 (3) T_{A,MAX} is 125°C for Q devices and 150°C for E devices (see [Figure 8-1](#)).

5.8 Typical Characteristics

$T_A > 125^\circ\text{C}$ data is valid for devices with the "E" temperature range designator only, (see [Device Nomenclature](#))

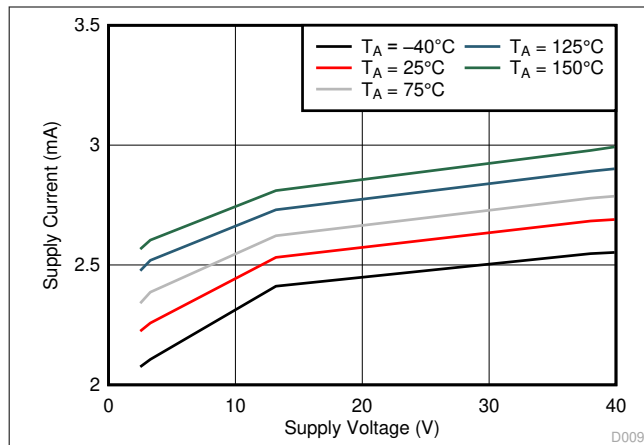

Versions: DRV5013AD, DRV5013AG, DRV5013BC, DRV5013FA

Figure 5-1. I_{CC} vs V_{CC}

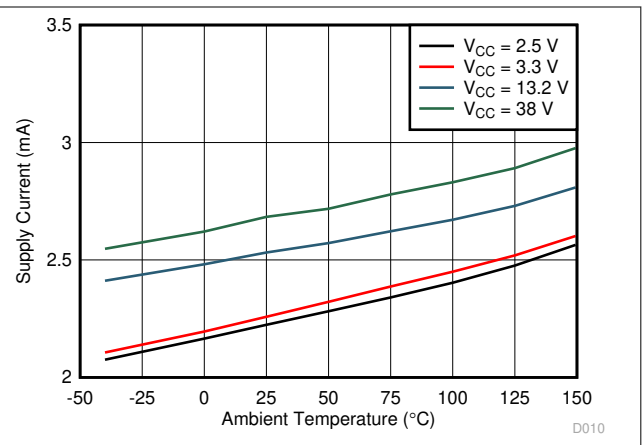

Versions: DRV5013AD, DRV5013AG, DRV5013BC, DRV5013FA

Figure 5-2. I_{CC} vs Temperature

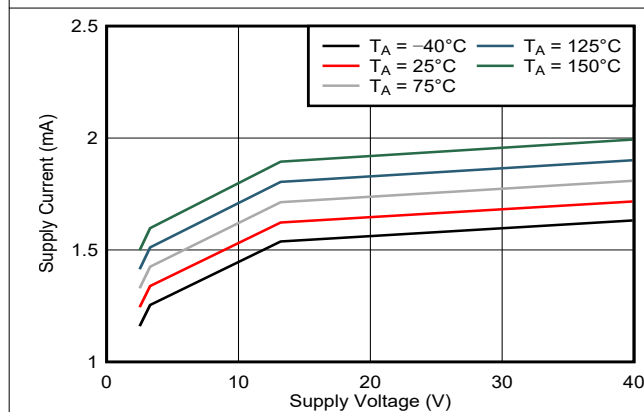

Version: DRV5013ND

Figure 5-3. I_{CC} vs V_{CC}

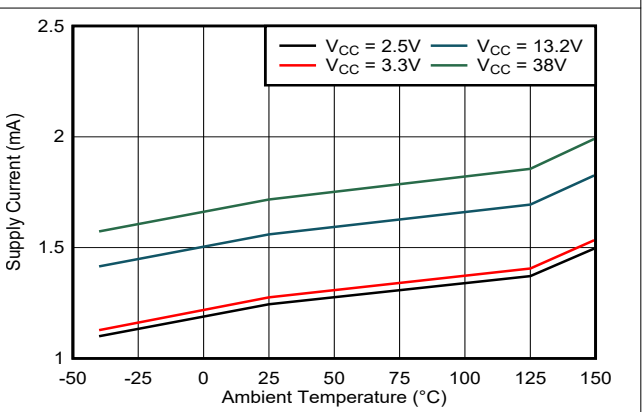

Version: DRV5013ND

Figure 5-4. I_{CC} vs Temperature

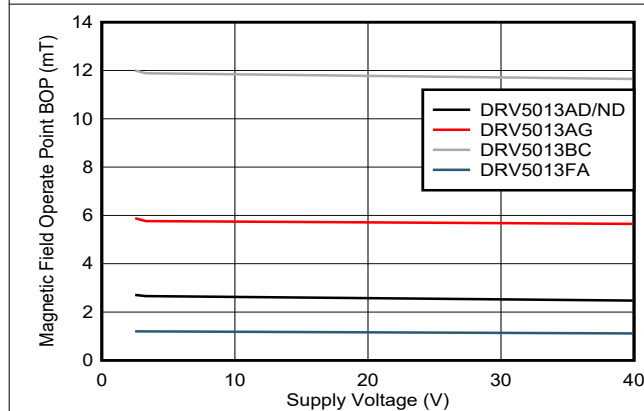

$T_A = 25^\circ\text{C}$

Figure 5-5. B_{OP} vs V_{CC}

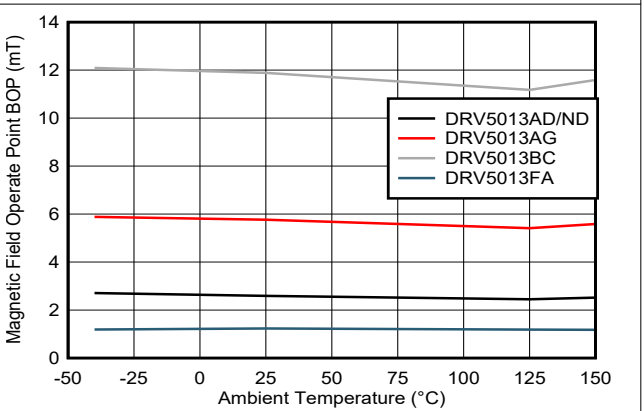

$V_{CC} = 3.3\text{ V}$

Figure 5-6. B_{OP} vs Temperature

5.8 Typical Characteristics (continued)

$T_A > 125^\circ\text{C}$ data is valid for devices with the "E" temperature range designator only, (see [Device Nomenclature](#))

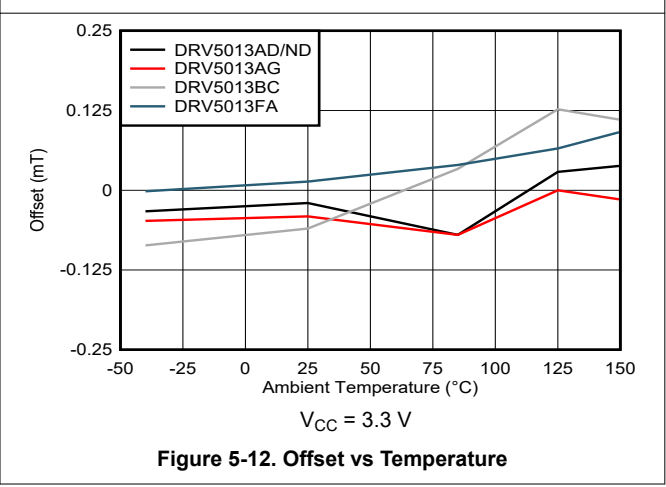
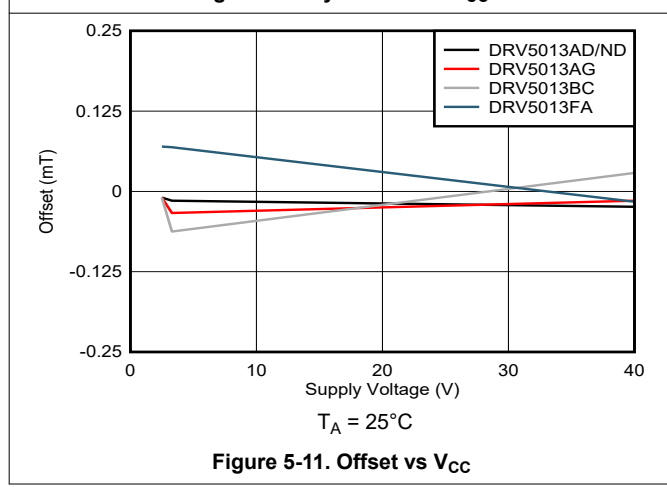
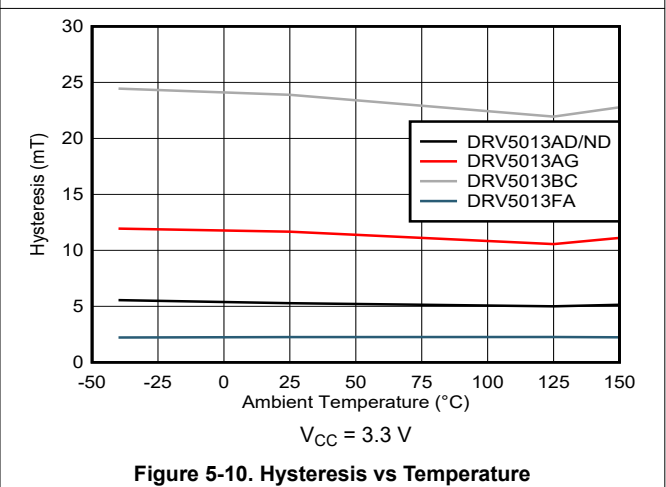
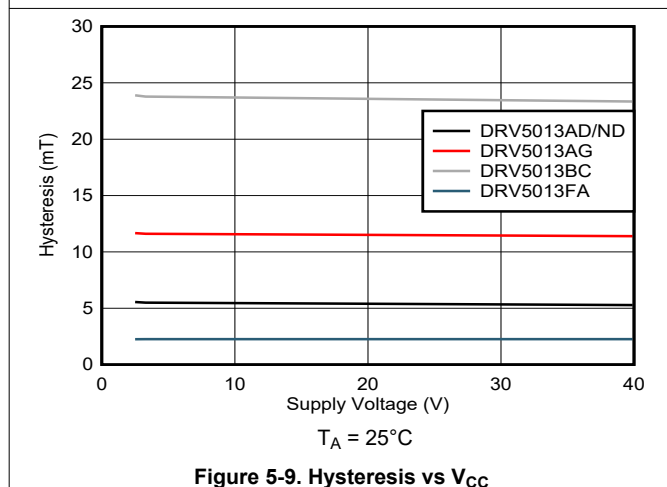
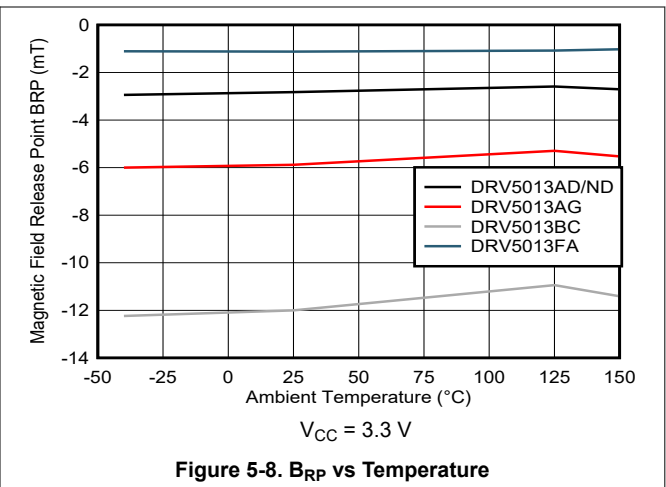
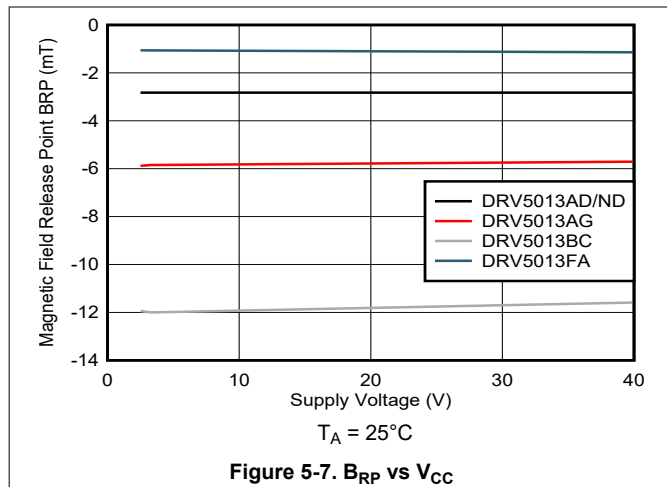

6 Detailed Description

6.1 Overview

The DRV5013 device is a chopper-stabilized Hall sensor with a digital latched output for magnetic sensing applications. The DRV5013 device can be powered with a supply voltage ranging from 2.5 V to 38 V, and continuously withstand -22 V reverse-battery conditions. The DRV5013 device does not operate when -22 V to 2.4 V is applied to the V_{CC} pin (with respect to the GND pin). In addition, the device can withstand voltages up to 40 V for transient durations.

The field polarity is defined as follows: a **south pole** near the marked side of the package induces a positive magnetic flux density on the sensor, while a **north pole** near the marked side of the package induces a negative magnetic flux density on the sensor.

The output state is dependent on the magnetic flux density perpendicular to the package. A positive magnetic flux density greater than the operate point threshold, B_{OP} , causes the output to pull low for the AD, AG, BC and FA device versions (release high for the inverted ND device version). A negative magnetic flux density less than the release point threshold, B_{RP} , causes the output to release high for the AD, AG, BC and FA device versions (pull low for the inverted ND device version). Hysteresis is included in between the operate point and the release point to help prevent magnetic noise from accidentally tripping the output.

An external pullup resistor is required on the OUT pin. The OUT pin can be pulled up to V_{CC} , or to a different voltage supply. This allows for easier interfacing with controller circuits.

6.2 Functional Block Diagram

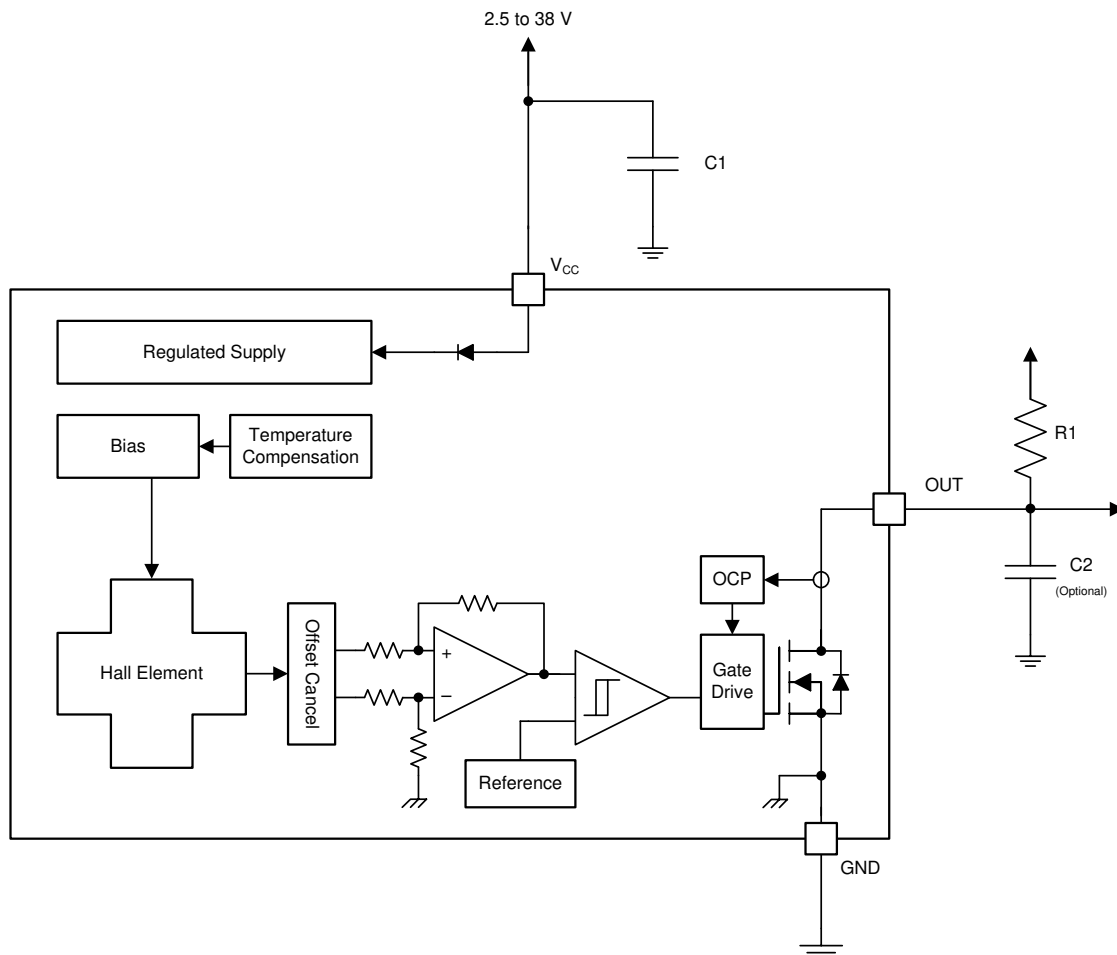

6.3 Feature Description

6.3.1 Field Direction Definition

Figure 6-1 illustrates that a positive magnetic flux density is defined as the presence of a south pole near the marked side of the package.

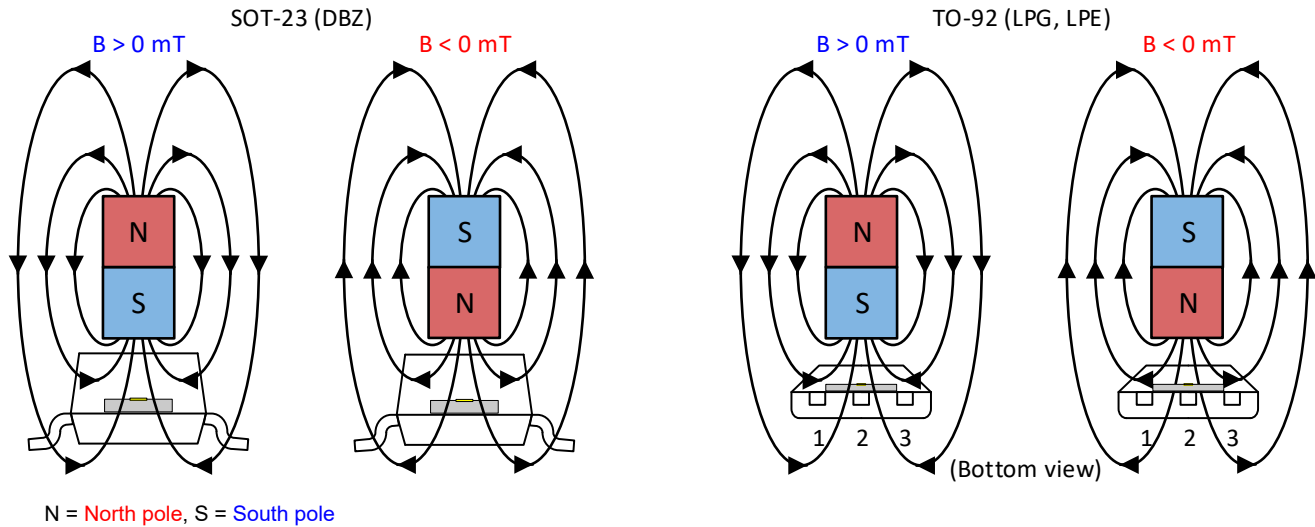

Figure 6-1. Field Direction Definition

6.3.2 Device Output

If the device is powered on with a magnetic flux density between B_{RP} and B_{OP} , then the device output is indeterminate and can either be Hi-Z or Low. If the magnetic flux density is greater than B_{OP} , then the output is pulled low (released high for the inverted ND version). If the magnetic flux density is less than B_{RP} , then the output is released high according to the output reference voltage and pullup resistor (pulled low for the inverted ND version).

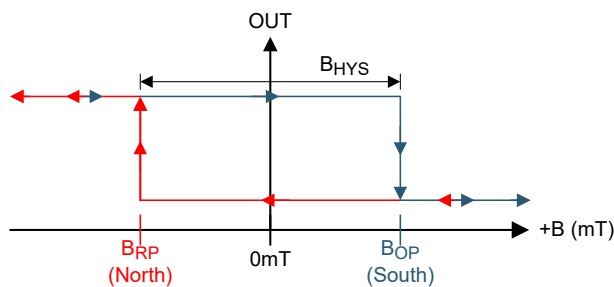

Figure 6-2. Output State (FA, AD, AG, BC Versions)

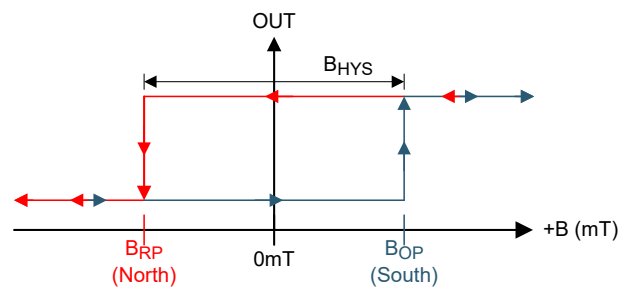

Figure 6-3. Inverted Output State (ND Version)

6.3.3 Power-On Time

After applying V_{CC} to the DRV5013 device, t_{on} must elapse before the OUT pin is valid. During the power-up sequence, the output is Hi-Z. A pulse as shown in Figure 6-4 and Figure 6-5 occurs at the end of t_{on} . This pulse can allow the host processor to determine when the DRV5013 output is valid after start-up. The power-up sequence, including the pulse, is the same for all device output versions (AD, AG, BC, FA, ND). Case 1, 2, 3 and 4 below show examples of valid outputs for the non-inverted output versions (AD, AG, BC, FA). In Case 1 (Figure 6-4) and Case 2 (Figure 6-5), the output is defined assuming a constant magnetic flux density $B > B_{OP}$ and $B < B_{RP}$.

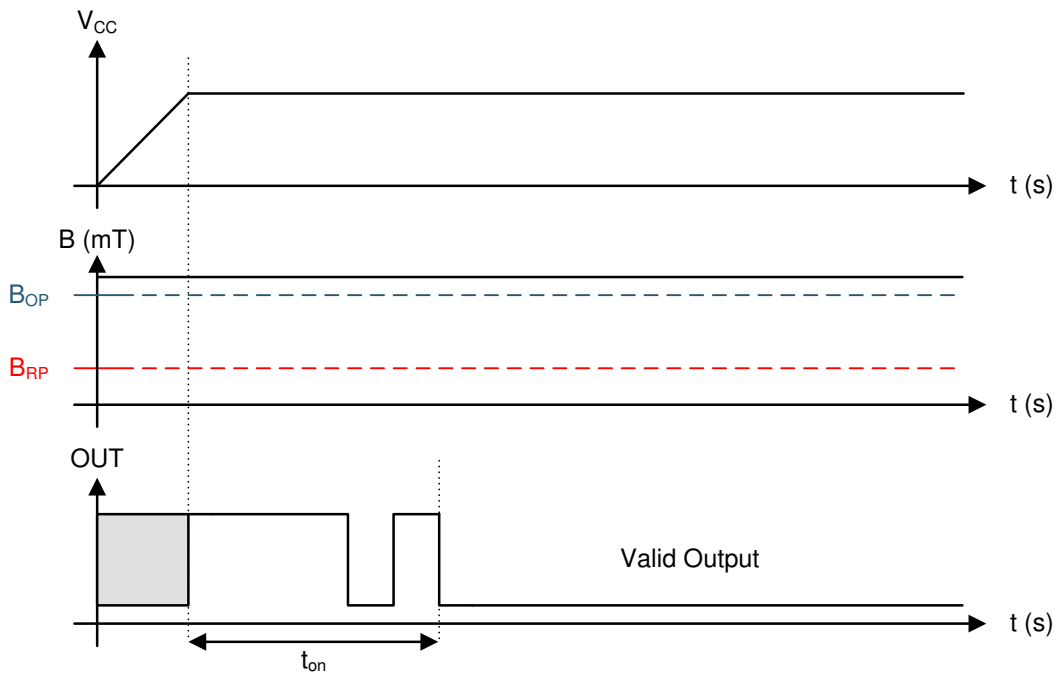

Figure 6-4. Case 1: Power On When $B > B_{OP}$

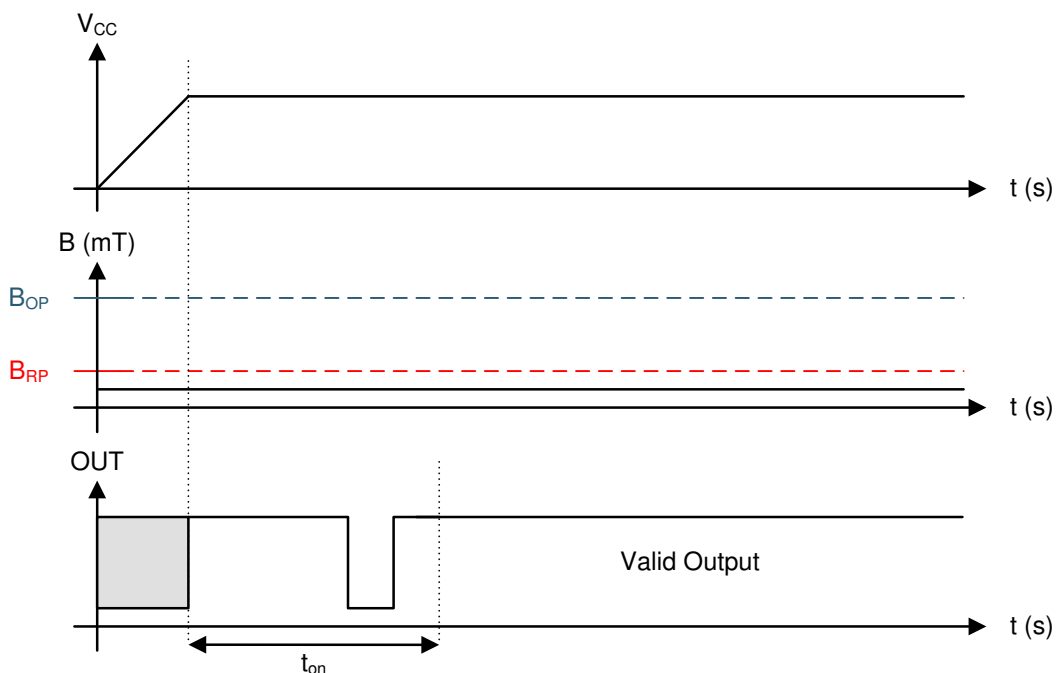

Figure 6-5. Case 2: Power On When $B < B_{RP}$

If the device is powered on with the magnetic flux density $B_{RP} < B < B_{OP}$, then the device output is indeterminate and can either be Hi-Z or pulled low. During the power-up sequence, the output is held Hi-Z until t_{on} has elapsed. At the end of t_{on} , a pulse is given on the OUT pin to indicate that t_{on} has elapsed. After t_{on} , if the magnetic flux density changes such that $B_{OP} < B$, the output is released. Case 3 (Figure 6-6) and Case 4 (Figure 6-7) show examples of this behavior.

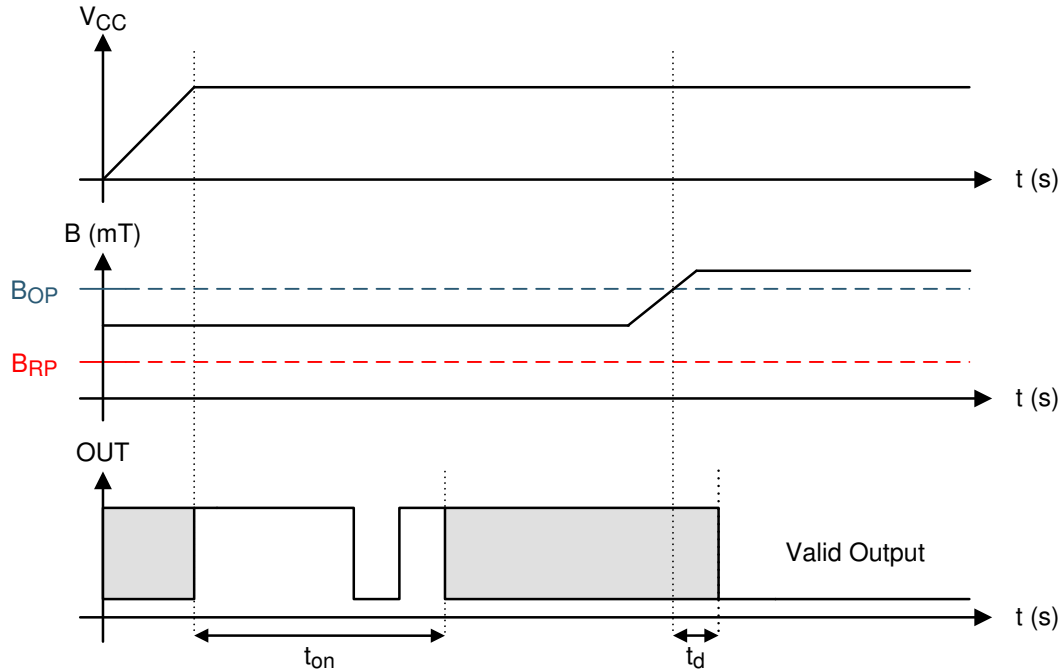

Figure 6-6. Case 3: Power On When $B_{RP} < B < B_{OP}$, Followed by $B > B_{OP}$

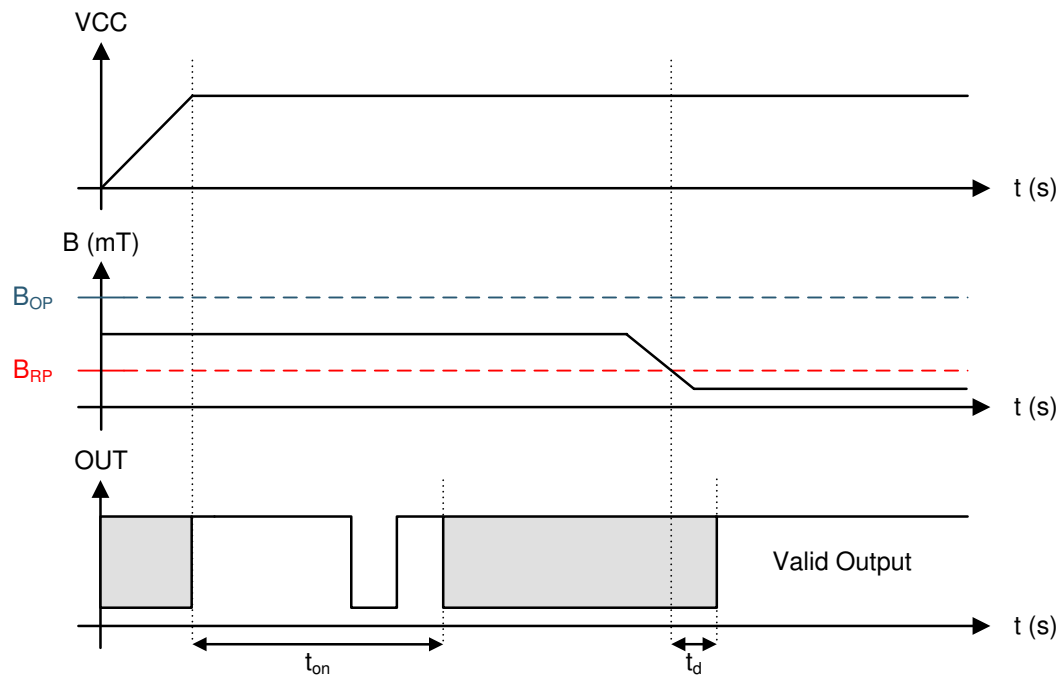

Figure 6-7. Case 4: Power On When $B_{RP} < B < B_{OP}$, Followed by $B < B_{RP}$

6.3.4 Output Stage

Figure 6-8 shows the DRV5013 open-drain NMOS output structure, rated to sink up to 30 mA of current. For proper operation, use Equation 1 to calculate the value of pull-up resistor R1.

$$\frac{V_{\text{ref max}}}{30 \text{ mA}} \leq R1 \leq \frac{V_{\text{ref min}}}{100 \mu\text{A}} \quad (1)$$

The size of R1 is a tradeoff between the OUT rise time and the current when OUT is pulled low. A lower current is generally better, however faster transitions and bandwidth require a smaller resistor for faster switching.

In addition, make sure that the value of R1 > 500 Ω so that the output driver can pull the OUT pin close to GND.

Note

V_{ref} is not restricted to V_{CC} . The allowable voltage range of this pin is specified in the [Absolute Maximum Ratings](#).

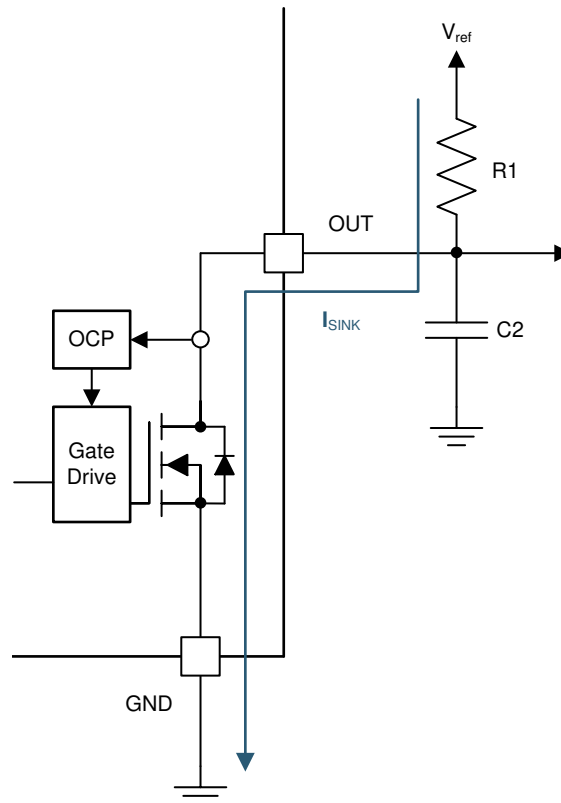

Figure 6-8. NMOS Open-Drain Output

Select a value for C2 based on the system bandwidth specifications as shown in Equation 2.

$$2 \times f_{\text{BW}} \text{ (Hz)} < \frac{1}{2\pi \times R1 \times C2} \quad (2)$$

Most applications do not require this C2 filtering capacitor.

6.3.5 Protection Circuits

The DRV5013 device is fully protected against overcurrent and reverse-supply conditions. [Table 6-1](#) lists a summary of the protection circuits.

Table 6-1. Protection Circuit Summary

FAULT	CONDITION	DEVICE	DESCRIPTION	RECOVERY
FET overload (OCP)	$I_{\text{SINK}} \geq I_{\text{OCP}}$	Operating	Output current is clamped to I_{OCP}	$I_o < I_{\text{OCP}}$
Load dump	$38 \text{ V} < V_{\text{CC}} < 40 \text{ V}$	Operating	Device will operate for a transient duration	$V_{\text{CC}} \leq 38 \text{ V}$
Reverse supply	$-22 \text{ V} < V_{\text{CC}} < 0 \text{ V}$	Disabled	Device will survive this condition	$V_{\text{CC}} \geq 2.5 \text{ V}$

6.3.5.1 Overcurrent Protection (OCP)

An analog current-limit circuit limits the current through the FET. The driver current is clamped to I_{OCP} . During this clamping, the $r_{\text{DS(on)}}$ of the output FET is increased from the nominal value.

6.3.5.2 Load Dump Protection

The DRV5013 device operates at DC V_{CC} conditions up to 38 V nominally, and can additionally withstand $V_{\text{CC}} = 40 \text{ V}$. No current-limiting series resistor is required for this protection.

6.3.5.3 Reverse Supply Protection

The DRV5013 device is protected in the event that the V_{CC} pin and the GND pin are reversed (up to -22 V).

Note

In a reverse supply condition, the OUT pin reverse-current must not exceed the ratings specified in the [Absolute Maximum Ratings](#).

6.4 Device Functional Modes

The DRV5013 device is active only when V_{CC} is between 2.5 V and 38 V.

When a reverse supply condition exists, the device is inactive.

7 Application and Implementation

Note

Information in the following applications sections is not part of the TI component specification, and TI does not warrant its accuracy or completeness. TI's customers are responsible for determining suitability of components for their purposes, as well as validating and testing their design implementation to confirm system functionality.

7.1 Application Information

The DRV5013 device is used in magnetic-field sensing applications.

7.2 Typical Applications

7.2.1 Standard Circuit

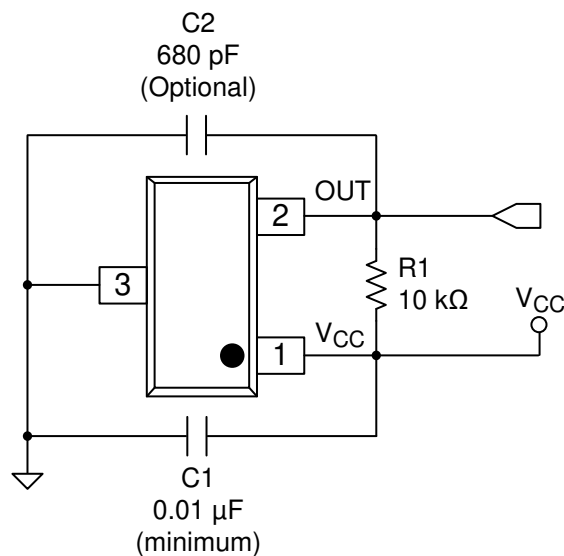

Figure 7-1. Typical Application Circuit

7.2.1.1 Design Requirements

For this design example, use the parameters listed in Table 7-1 as the input parameters.

Table 7-1. Design Parameters

DESIGN PARAMETER	REFERENCE	EXAMPLE VALUE
Supply voltage	V_{CC}	3.2 to 3.4 V
System bandwidth	f_{BW}	10 kHz

7.2.1.2 Detailed Design Procedure

Table 7-2. External Components

COMPONENT	PIN 1	PIN 2	RECOMMENDED
C1	V_{CC}	GND	A 0.01- μ F (minimum) ceramic capacitor rated for V_{CC}
C2	OUT	GND	Optional: Place a ceramic capacitor to GND
R1	OUT	REF ⁽¹⁾	Requires a resistor pullup

(1) REF is not a pin on the DRV5013 device, but a REF supply-voltage pullup is required for the OUT pin; the OUT pin may be pulled up to V_{CC} .

7.2.1.2.1 Configuration Example

In a 3.3-V system, $3.2 \text{ V} \leq V_{\text{ref}} \leq 3.4 \text{ V}$. Use [Equation 3](#) to calculate the allowable range for R1.

$$\frac{V_{\text{ref max}}}{30 \text{ mA}} \leq R1 \leq \frac{V_{\text{ref min}}}{100 \mu\text{A}} \quad (3)$$

For this design example, use [Equation 4](#) to calculate the allowable range of R1.

$$\frac{3.4 \text{ V}}{30 \text{ mA}} \leq R1 \leq \frac{3.2 \text{ V}}{100 \mu\text{A}} \quad (4)$$

Therefore:

$$113 \Omega \leq R1 \leq 32 \text{ k}\Omega \quad (5)$$

After finding the allowable range of R1 ([Equation 5](#)), select a value between 500 Ω and 32 k Ω for R1.

Assuming a system bandwidth of 10 kHz, use [Equation 6](#) to calculate the value of C2.

$$2 \times f_{\text{BW}} (\text{Hz}) < \frac{1}{2\pi \times R1 \times C2} \quad (6)$$

For this design example, use [Equation 7](#) to calculate the value of C2.

$$2 \times 10 \text{ kHz} < \frac{1}{2\pi \times R1 \times C2} \quad (7)$$

An R1 value of 10 k Ω and a C2 value less than 820 pF satisfy the requirement for a 10-kHz system bandwidth.

A selection of R1 = 10 k Ω and C2 = 680 pF would cause a low-pass filter with a corner frequency of 23.4 kHz.

7.2.1.3 Application Curves

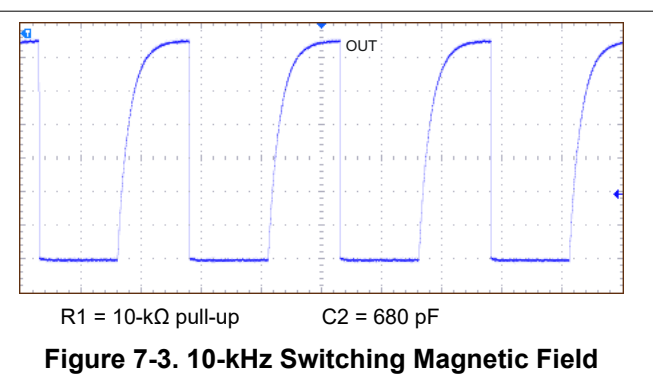
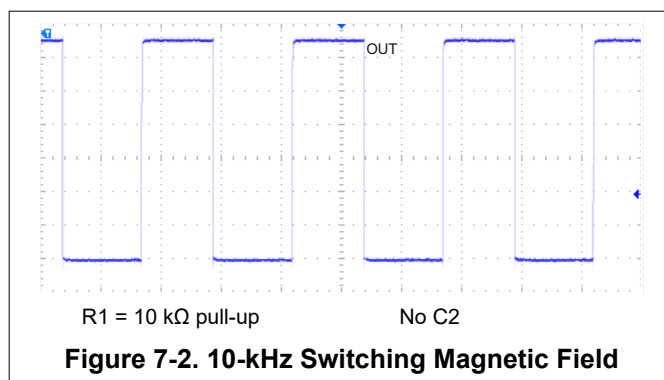

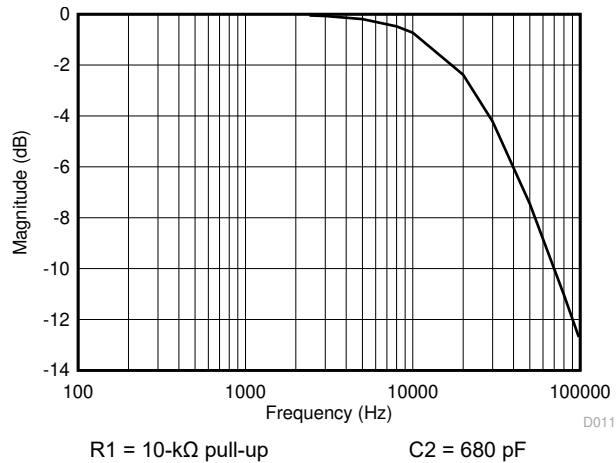

Figure 7-4. Low-Pass Filtering

7.2.2 Alternative Two-Wire Application

For systems that require minimal wire count, the device output can be connected to V_{CC} through a resistor, and the total supplied current can be sensed near the controller.

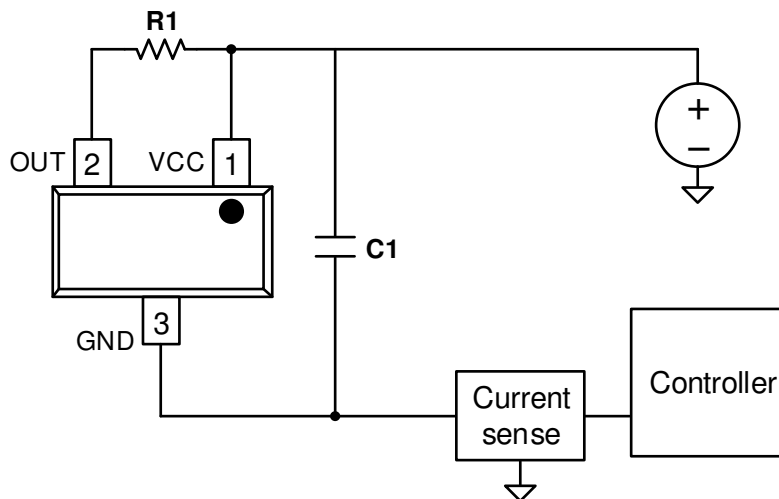

Figure 7-5. 2-Wire Application

Current can be sensed using a shunt resistor or other circuitry.

7.2.2.1 Design Requirements

Table 7-3 lists the related design parameters.

Table 7-3. Design Parameters

DESIGN PARAMETER	REFERENCE	EXAMPLE VALUE
Supply voltage	V_{CC}	12 V
OUT resistor	R1	1 kΩ
Bypass capacitor	C1	0.1 μF
Current when $B < B_{RP}$	$I_{RELEASE}$	About 3 mA
Current when $B > B_{OP}$	$I_{OPERATE}$	About 15 mA

7.2.2.2 Detailed Design Procedure

When the open-drain output of the device is high-impedance, current through the path equals the I_{CC} of the device (approximately 3 mA).

When the output pulls low, a parallel current path is added, equal to $V_{CC} / (R1 + r_{DS(on)})$. Using 12 V and 1 k Ω , the parallel current is approximately 12 mA, making the total current approximately 15 mA.

The local bypass capacitor C1 should be at least 0.1 μ F, and a larger value if there is high inductance in the power line interconnect.

7.3 Power Supply Recommendations

The DRV5013 device is designed to operate from an input voltage supply (VM) range between 2.5 V and 38 V. A 0.01- μ F (minimum) ceramic capacitor rated for V_{CC} must be placed as close to the DRV5013 device as possible. Larger values of the bypass capacitor may be needed to attenuate any significant high-frequency ripple and noise components generated by the power source. TI recommends limiting the supply voltage variation to less than 50 mV_{PP}.

7.4 Layout

7.4.1 Layout Guidelines

The bypass capacitor should be placed near the DRV5013 device for efficient power delivery with minimal inductance. The external pullup resistor should be placed near the microcontroller input to provide the most stable voltage at the input; alternatively, an integrated pullup resistor within the GPIO of the microcontroller can be used.

Generally, using PCB copper planes underneath the DRV5013 device has no effect on magnetic flux, and does not interfere with device performance. This is because copper is not a ferromagnetic material. However, if nearby system components contain iron or nickel, they may redirect magnetic flux in unpredictable ways.

7.4.2 Layout Example

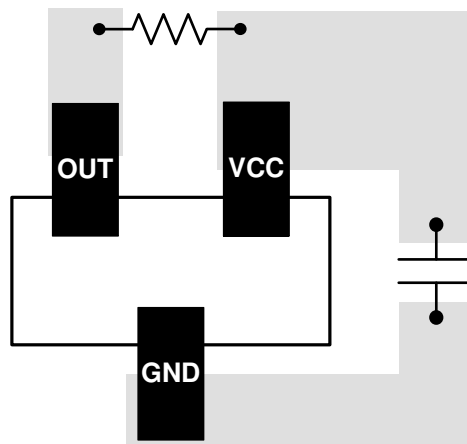

Figure 7-6. DRV5013 Layout Example

8 Device and Documentation Support

8.1 Device Support

8.1.1 Device Nomenclature

Figure 8-1 shows a legend for reading the complete orderable part numbers for the DRV5013.

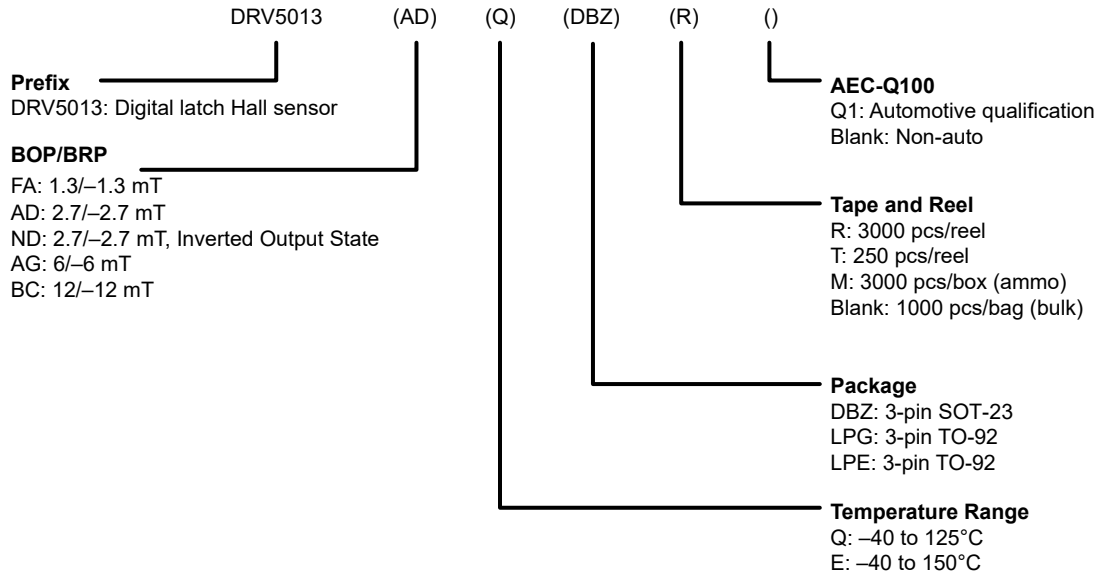

Figure 8-1. Device Nomenclature

8.1.2 Device Markings

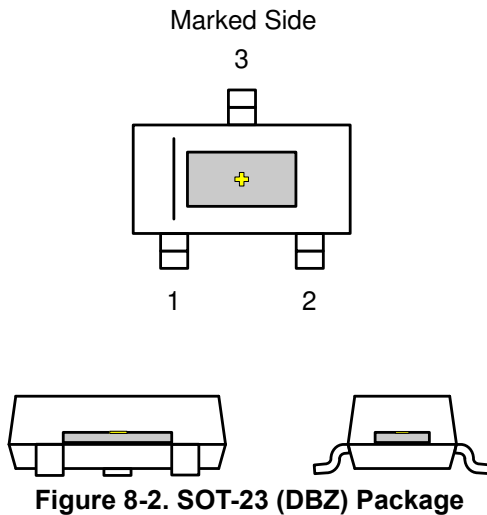

Figure 8-2. SOT-23 (DBZ) Package

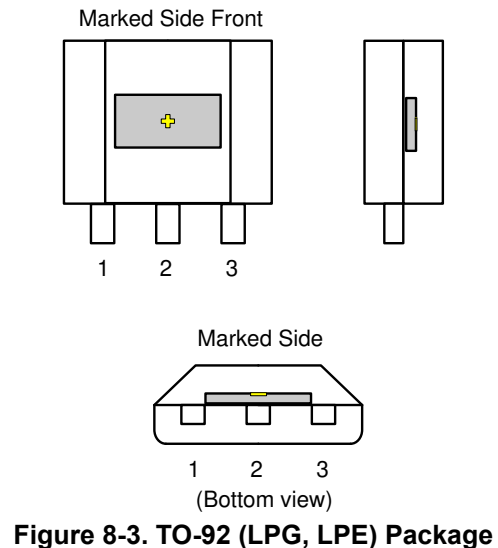

Figure 8-3. TO-92 (LPG, LPE) Package

8.2 Receiving Notification of Documentation Updates

To receive notification of documentation updates, navigate to the device product folder on ti.com. Click on *Notifications* to register and receive a weekly digest of any product information that has changed. For change details, review the revision history included in any revised document.

8.3 Support Resources

[TI E2E™ support forums](#) are an engineer's go-to source for fast, verified answers and design help — straight from the experts. Search existing answers or ask your own question to get the quick design help you need.

Linked content is provided "AS IS" by the respective contributors. They do not constitute TI specifications and do not necessarily reflect TI's views; see TI's [Terms of Use](#).

8.4 Trademarks

TI E2E™ is a trademark of Texas Instruments.

All trademarks are the property of their respective owners.

8.5 Electrostatic Discharge Caution



This integrated circuit can be damaged by ESD. Texas Instruments recommends that all integrated circuits be handled with appropriate precautions. Failure to observe proper handling and installation procedures can cause damage.

ESD damage can range from subtle performance degradation to complete device failure. Precision integrated circuits may be more susceptible to damage because very small parametric changes could cause the device not to meet its published specifications.

8.6 Glossary

[TI Glossary](#) This glossary lists and explains terms, acronyms, and definitions.

9 Revision History

NOTE: Page numbers for previous revisions may differ from page numbers in the current version.

Changes from Revision L (February 2023) to Revision M (June 2024)	Page
• Added ND device information to the data sheet.....	1
• Changed the temperature condition statement in the <i>Typical Characteristics</i> section header.....	7
• Added graphs to the <i>Typical Characteristics</i> section to include the DRV5013ND and DRV5013FA device versions.....	7
• Added text to the <i>Overview</i> section to highlight the differences between the inverted and non-inverted output device versions.....	9
• Changed the <i>Field Direction Definition</i> section	10
• Added text to the <i>Device Output</i> section to highlight the differences between the inverted and non-inverted output device versions.....	10
• Added text to the <i>Power-On Time</i> section to highlight the differences between the inverted and non-inverted output device versions.....	11

Changes from Revision K (August 2019) to Revision L (February 2023)	Page
• Updated the numbering format for tables, figures, and cross-references throughout the document.....	1
• Changed table title from: Device Information to: Package Information.....	1
• Moved the <i>Power Supply Recommendations</i> and <i>Layout</i> sections to the <i>Application and Implementation</i> section.....	18

Changes from Revision J (June 2019) to Revision K (August 2019)	Page
• Changed T_J to show existing range is for Q version device in the <i>Absolute Maximum Ratings</i> table.....	4
• Added E version for T_J to the <i>Absolute Maximum Ratings</i> table.....	4
• Changed T_A to show existing range is for Q version device in the <i>Recommended Operating Conditions</i> table.....	4
• Added E version for T_A to the <i>Recommended Operating Conditions</i> table.....	4
• Changed I_{CC} test condition for T_A from 125 to $T_{A,MAX}$ to highlight the differences between the E and Q version devices.....	5

• Changed $r_{DS(on)}$ test condition for T_A from 125 to $T_{A,MAX}$ to highlight the difference between the E and Q version devices.....	5
• Changed all test conditions for T_A max from 125 to $T_{A,MAX}$ to highlight difference between the E and Q devices.....	5
• Added new condition statement to <i>Typical Characteristics</i> section.....	7
• Added data up to 150°C to Figure 1, Figure 2, Figure 4, Figure 6, Figure 8, and Figure 10.....	7

Changes from Revision I (August 2018) to Revision J (June 2019)	Page
• Added TO-92 (LPE) package to data sheet	1

Changes from Revision H (September 2016) to Revision I (August 2018)	Page
• Changed <i>Power Supply Recommendations</i> section	18

Changes from Revision G (August 2016) to Revision H (September 2016)	Page
• Changed the power-on time for the FA version in the <i>Electrical Characteristics</i> table.....	5

Changes from Revision F (May 2016) to Revision G (August 2016)	Page
• Changed the maximum B_{OP} and the minimum B_{RP} for the FA version in the Magnetic Characteristics table...	5
• Added the <i>Layout</i> section.....	18

Changes from Revision E (February 2016) to Revision F (May 2016)	Page
• Revised preliminary limits for the FA version.....	5

Changes from Revision D (December 2015) to Revision E (February 2016)	Page
• Added the FA device option.....	1
• Added the typical bandwidth value to <i>Magnetic Characteristics</i> table.....	5

Changes from Revision C (September 2014) to Revision D (June 2015)	Page
• Corrected body size of SOT-23 package and SIP package name to TO-92	1
• Added B_{MAX} to <i>Absolute Maximum Ratings</i>	4
• Removed table note from junction temperature.....	4
• Added <i>Community Resources</i>	19
• Updated package tape and reel options for M and blank	19

Changes from Revision B (July 2014) to Revision C (September 2014)	Page
• Updated high sensitivity options	1
• Changed the max operating junction temperature to 150°C.....	4
• Updated the output rise and fall time typical values and removed max values in <i>Switching Characteristics</i>	5
• Updated the values in <i>Magnetic Characteristics</i>	5
• Updated all <i>Typical Characteristics</i> graphs	7
• Updated Equation 4	16

- Updated [Device Nomenclature](#) 19

Changes from Revision A (March 2014) to Revision B (June 2014) Page

- Changed I_{OCP} MIN and MAX values from 20 and 40 to 15 and 45, respectively, in the *Electrical Characteristics* 5
- Changed the MIN value for the ±2.3 mT B_{RP} parameter from –4 to –5 in the *Magnetic Characteristics* table... 5
- Updated the hysteresis values for each device option in the *Magnetic Characteristics* table..... 5

Changes from Revision * (March 2014) to Revision A (March 2014) Page

- Changed all references to Hall IC to Hall Effect Sensor 1
- Changed *RPM Meter* to *Tachometers* in the *Applications* list 1
- Changed the power-on value from 50 to 35 μs in the *Features* list 1
- Changed the type of the OUT terminal from OD to Output in the *Pin Functions* table 3
- Deleted Output pin current and changed V_{CC}max to V_{CC} after the voltage ramp rate for the supply voltage... 4
- Changed R_O to R1 in the test conditions for t_r and t_f in the *Switching Characteristics* table..... 5
- Added the bandwidth parameter to *Magnetic Characteristics* table..... 5
- Changed the MIN value for the ±2.3 mT B_{RP} parameter from +2.3 to –2.3 in the *Magnetic Characteristics* table 5
- Deleted condition statement from the *Typical Characteristics* and changed all T_J to T_A in the graph conditions 7
- Deleted *Number* from the Power-On Time case names; added conditions to captions of case timing diagrams 11
- Added the R1 tradeoff and lower current text after the equation in the *Output Stage* section 13
- Added the C2 not required for most applications text after the second equation in the *Output Stage* section. 13
- Changed I_O to I_{SINK} in condition statement of FET overload fault condition in *Reverse Supply Protection* section..... 14

10 Mechanical, Packaging, and Orderable Information

The following pages include mechanical, packaging, and orderable information. This information is the most current data available for the designated devices. This data is subject to change without notice and revision of this document. For browser-based versions of this data sheet, refer to the left-hand navigation.

PACKAGING INFORMATION

Orderable Device	Status (1)	Package Type	Package Drawing	Pins	Package Qty	Eco Plan (2)	Lead finish/ Ball material (6)	MSL Peak Temp (3)	Op Temp (°C)	Device Marking (4/5)	Samples
DRV5013ADQDBZR	ACTIVE	SOT-23	DBZ	3	3000	RoHS & Green	NIPDAUAG SN	Level-1-260C-UNLIM	-40 to 125	(+NLAD, 13AD, 1J52)	Samples
DRV5013ADQDBZT	OBSOLETE	SOT-23	DBZ	3		TBD	Call TI	Call TI	-40 to 125	(+NLAD, 13AD, 1J52)	
DRV5013ADQLPG	ACTIVE	TO-92	LPG	3	1000	RoHS & Green	SN	N / A for Pkg Type	-40 to 125	+NLAD	Samples
DRV5013ADQLPGM	ACTIVE	TO-92	LPG	3	3000	RoHS & Green	SN	N / A for Pkg Type	-40 to 125	+NLAD	Samples
DRV5013AGQDBZR	ACTIVE	SOT-23	DBZ	3	3000	RoHS & Green	NIPDAUAG SN	Level-1-260C-UNLIM	-40 to 125	(+NLAG, 13AG, 1IW2)	Samples
DRV5013AGQDBZT	OBSOLETE	SOT-23	DBZ	3		TBD	Call TI	Call TI	-40 to 125	(+NLAG, 13AG, 1IW2)	
DRV5013AGQLPG	ACTIVE	TO-92	LPG	3	1000	RoHS & Green	SN	N / A for Pkg Type	-40 to 125	+NLAG	Samples
DRV5013AGQLPGM	ACTIVE	TO-92	LPG	3	3000	RoHS & Green	SN	N / A for Pkg Type	-40 to 125	+NLAG	Samples
DRV5013BCELPE	ACTIVE	TO-92	LPE	3	1000	RoHS & Green	SN	N / A for Pkg Type	-40 to 150	1UVJ	Samples
DRV5013BCELPEM	ACTIVE	TO-92	LPE	3	3000	RoHS & Green	SN	N / A for Pkg Type	-40 to 150	1UVJ	Samples
DRV5013BCQDBZR	ACTIVE	SOT-23	DBZ	3	3000	RoHS & Green	NIPDAUAG SN	Level-1-260C-UNLIM	-40 to 125	(+NLBC, 1IX2)	Samples
DRV5013BCQDBZT	OBSOLETE	SOT-23	DBZ	3		TBD	Call TI	Call TI	-40 to 125	(+NLBC, 1IX2)	
DRV5013BCQLPG	ACTIVE	TO-92	LPG	3	1000	RoHS & Green	SN	N / A for Pkg Type	-40 to 125	+NLBC	Samples
DRV5013BCQLPGM	ACTIVE	TO-92	LPG	3	3000	RoHS & Green	SN	N / A for Pkg Type	-40 to 125	+NLBC	Samples
DRV5013FAQDBZR	ACTIVE	SOT-23	DBZ	3	3000	RoHS & Green	SN	Level-1-260C-UNLIM	-40 to 125	(+NLFA, 1IZ2)	Samples
DRV5013NDQDBZR	ACTIVE	SOT-23	DBZ	3	3000	RoHS & Green	SN	Level-1-260C-UNLIM	-40 to 125	13ND	Samples

(1) The marketing status values are defined as follows:

ACTIVE: Product device recommended for new designs.

LIFEBUY: TI has announced that the device will be discontinued, and a lifetime-buy period is in effect.

NRND: Not recommended for new designs. Device is in production to support existing customers, but TI does not recommend using this part in a new design.

PREVIEW: Device has been announced but is not in production. Samples may or may not be available.

OBSOLETE: TI has discontinued the production of the device.

(2) **RoHS:** TI defines "RoHS" to mean semiconductor products that are compliant with the current EU RoHS requirements for all 10 RoHS substances, including the requirement that RoHS substance do not exceed 0.1% by weight in homogeneous materials. Where designed to be soldered at high temperatures, "RoHS" products are suitable for use in specified lead-free processes. TI may reference these types of products as "Pb-Free".

RoHS Exempt: TI defines "RoHS Exempt" to mean products that contain lead but are compliant with EU RoHS pursuant to a specific EU RoHS exemption.

Green: TI defines "Green" to mean the content of Chlorine (Cl) and Bromine (Br) based flame retardants meet JS709B low halogen requirements of ≤ 1000 ppm threshold. Antimony trioxide based flame retardants must also meet the ≤ 1000 ppm threshold requirement.

(3) MSL, Peak Temp. - The Moisture Sensitivity Level rating according to the JEDEC industry standard classifications, and peak solder temperature.

(4) There may be additional marking, which relates to the logo, the lot trace code information, or the environmental category on the device.

(5) Multiple Device Markings will be inside parentheses. Only one Device Marking contained in parentheses and separated by a "~" will appear on a device. If a line is indented then it is a continuation of the previous line and the two combined represent the entire Device Marking for that device.

(6) Lead finish/Ball material - Orderable Devices may have multiple material finish options. Finish options are separated by a vertical ruled line. Lead finish/Ball material values may wrap to two lines if the finish value exceeds the maximum column width.

Important Information and Disclaimer:The information provided on this page represents TI's knowledge and belief as of the date that it is provided. TI bases its knowledge and belief on information provided by third parties, and makes no representation or warranty as to the accuracy of such information. Efforts are underway to better integrate information from third parties. TI has taken and continues to take reasonable steps to provide representative and accurate information but may not have conducted destructive testing or chemical analysis on incoming materials and chemicals. TI and TI suppliers consider certain information to be proprietary, and thus CAS numbers and other limited information may not be available for release.

In no event shall TI's liability arising out of such information exceed the total purchase price of the TI part(s) at issue in this document sold by TI to Customer on an annual basis.

OTHER QUALIFIED VERSIONS OF DRV5013 :

- Automotive : [DRV5013-Q1](#)

NOTE: Qualified Version Definitions:

- Automotive - Q100 devices qualified for high-reliability automotive applications targeting zero defects

TAPE AND REEL INFORMATION

QUADRANT ASSIGNMENTS FOR PIN 1 ORIENTATION IN TAPE

*All dimensions are nominal

Device	Package Type	Package Drawing	Pins	SPQ	Reel Diameter (mm)	Reel Width W1 (mm)	A0 (mm)	B0 (mm)	K0 (mm)	P1 (mm)	W (mm)	Pin1 Quadrant
DRV5013ADQDBZR	SOT-23	DBZ	3	3000	180.0	8.4	3.2	2.85	1.3	4.0	8.0	Q3
DRV5013AGQDBZR	SOT-23	DBZ	3	3000	180.0	8.4	3.2	2.85	1.3	4.0	8.0	Q3
DRV5013BCQDBZR	SOT-23	DBZ	3	3000	180.0	8.4	3.2	2.85	1.3	4.0	8.0	Q3
DRV5013FAQDBZR	SOT-23	DBZ	3	3000	180.0	8.4	3.15	2.77	1.22	4.0	8.0	Q3
DRV5013FAQDBZR	SOT-23	DBZ	3	3000	180.0	8.4	3.2	2.85	1.3	4.0	8.0	Q3
DRV5013NDQDBZR	SOT-23	DBZ	3	3000	180.0	8.4	3.2	2.85	1.3	4.0	8.0	Q3

TAPE AND REEL BOX DIMENSIONS

*All dimensions are nominal

Device	Package Type	Package Drawing	Pins	SPQ	Length (mm)	Width (mm)	Height (mm)
DRV5013ADQDBZR	SOT-23	DBZ	3	3000	210.0	185.0	35.0
DRV5013AGQDBZR	SOT-23	DBZ	3	3000	210.0	185.0	35.0
DRV5013BCQDBZR	SOT-23	DBZ	3	3000	210.0	185.0	35.0
DRV5013FAQDBZR	SOT-23	DBZ	3	3000	202.0	201.0	28.0
DRV5013FAQDBZR	SOT-23	DBZ	3	3000	210.0	185.0	35.0
DRV5013NDQDBZR	SOT-23	DBZ	3	3000	210.0	185.0	35.0

DBZ0003A

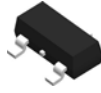

PACKAGE OUTLINE

SOT-23 - 1.12 mm max height

SMALL OUTLINE TRANSISTOR

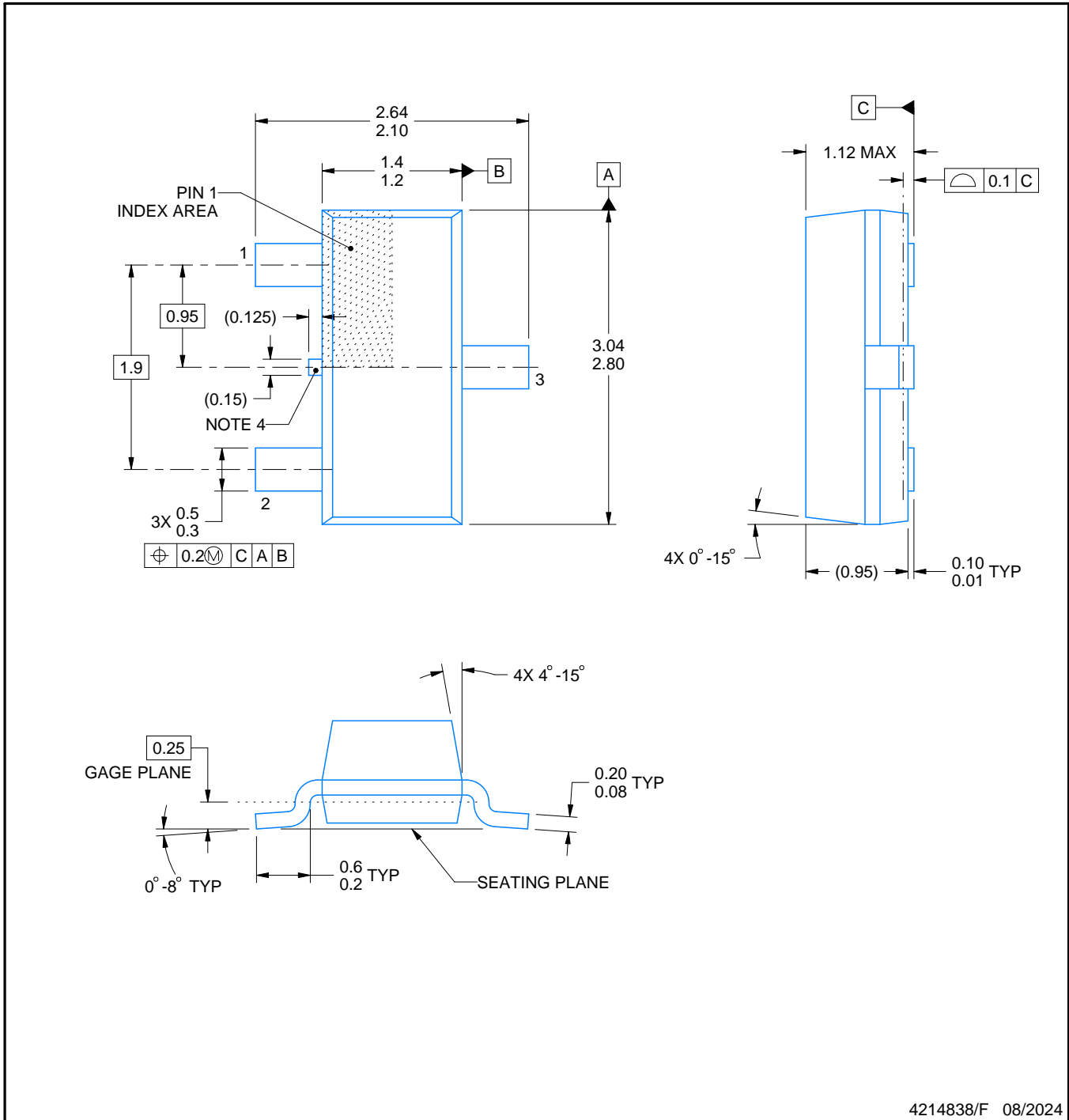

4214838/F 08/2024

NOTES:

1. All linear dimensions are in millimeters. Any dimensions in parenthesis are for reference only. Dimensioning and tolerancing per ASME Y14.5M.
2. This drawing is subject to change without notice.
3. Reference JEDEC registration TO-236, except minimum foot length.
4. Support pin may differ or may not be present.
5. Body dimensions do not include mold flash, protrusions, or gate burrs. Mold flash, protrusions, or gate burrs shall not exceed 0.25mm per side

EXAMPLE BOARD LAYOUT

DBZ0003A

SOT-23 - 1.12 mm max height

SMALL OUTLINE TRANSISTOR

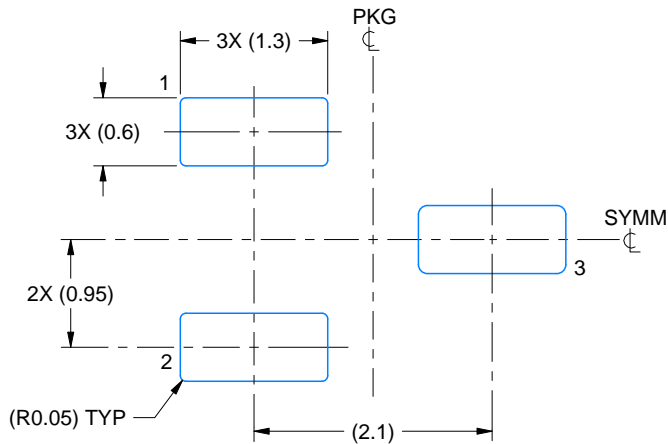

LAND PATTERN EXAMPLE
SCALE:15X

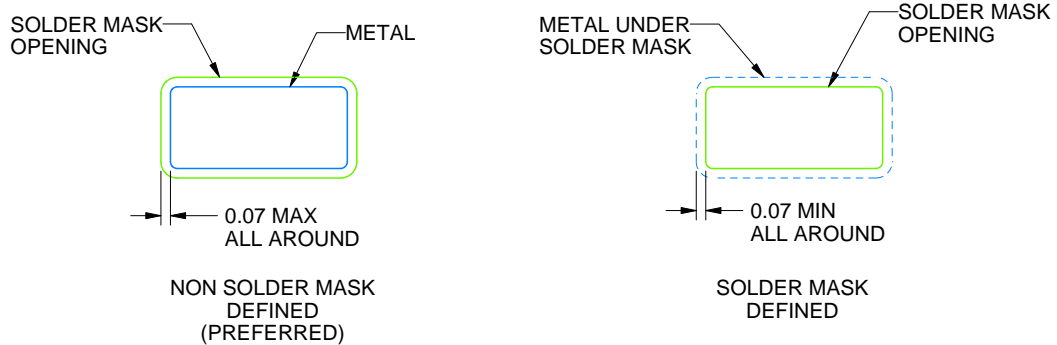

SOLDER MASK DETAILS

4214838/F 08/2024

NOTES: (continued)

- 5. Publication IPC-7351 may have alternate designs.
- 6. Solder mask tolerances between and around signal pads can vary based on board fabrication site.

EXAMPLE STENCIL DESIGN

DBZ0003A

SOT-23 - 1.12 mm max height

SMALL OUTLINE TRANSISTOR

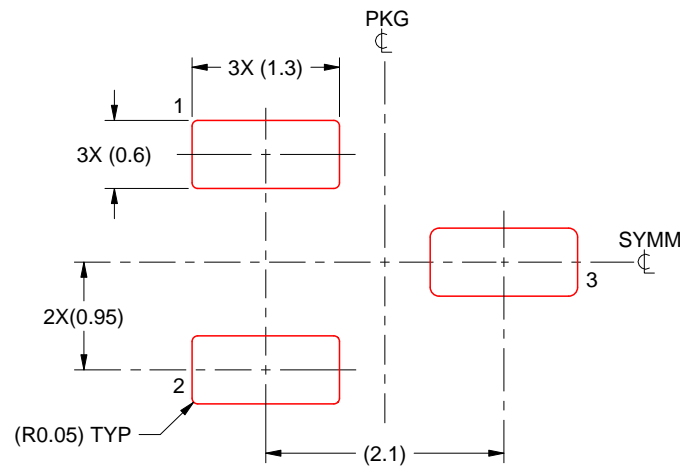

SOLDER PASTE EXAMPLE
BASED ON 0.125 THICK STENCIL
SCALE:15X

4214838/F 08/2024

NOTES: (continued)

7. Laser cutting apertures with trapezoidal walls and rounded corners may offer better paste release. IPC-7525 may have alternate design recommendations.
8. Board assembly site may have different recommendations for stencil design.

LPE0003A



PACKAGE OUTLINE

TO-92 - 5.05 mm max height

TRANSISTOR OUTLINE

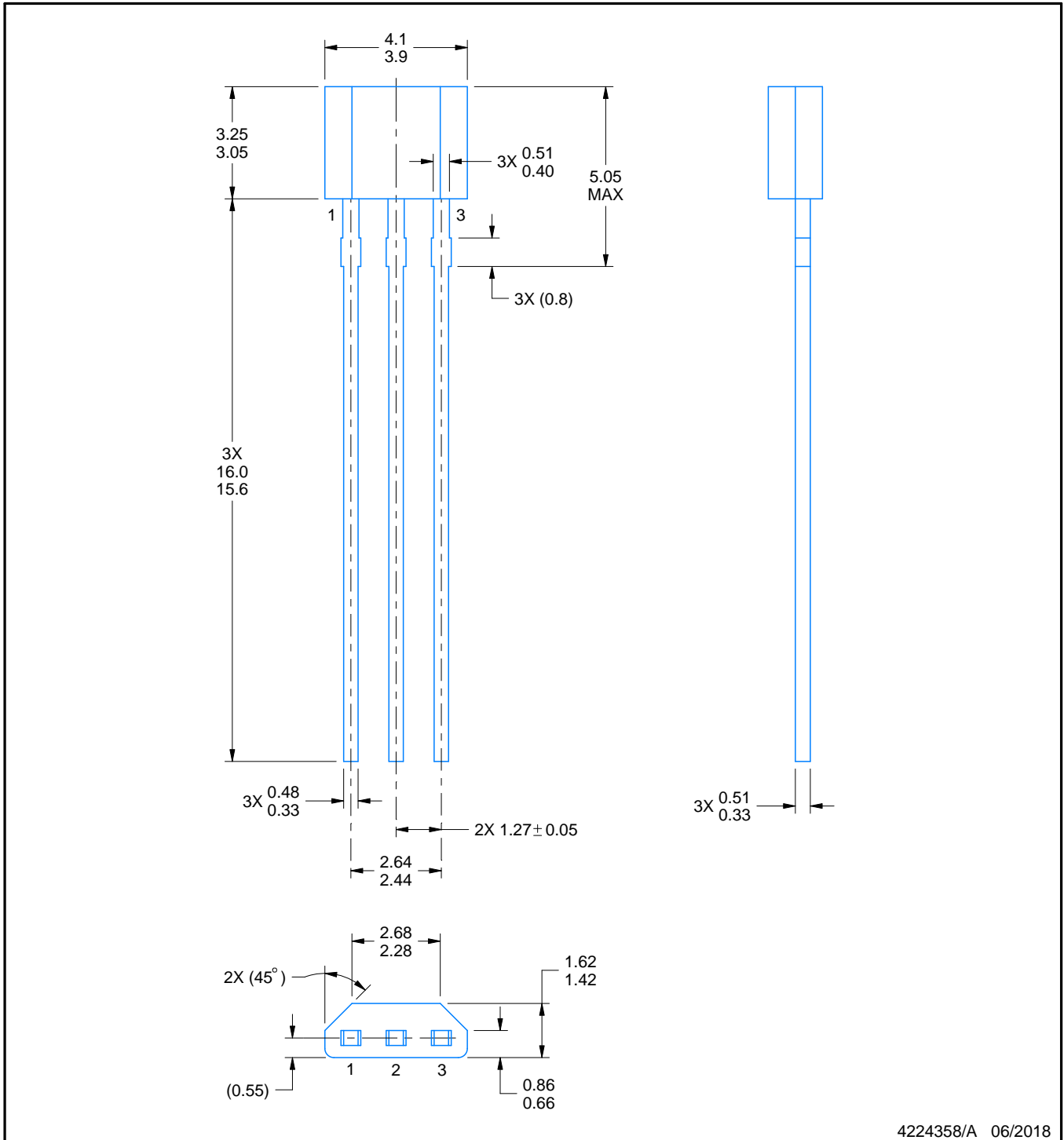

4224358/A 06/2018

NOTES:

1. All linear dimensions are in millimeters. Any dimensions in parenthesis are for reference only. Dimensioning and tolerancing per ASME Y14.5M.
2. This drawing is subject to change without notice.

EXAMPLE BOARD LAYOUT

LPE0003A

TO-92 - 5.05 mm max height

TRANSISTOR OUTLINE

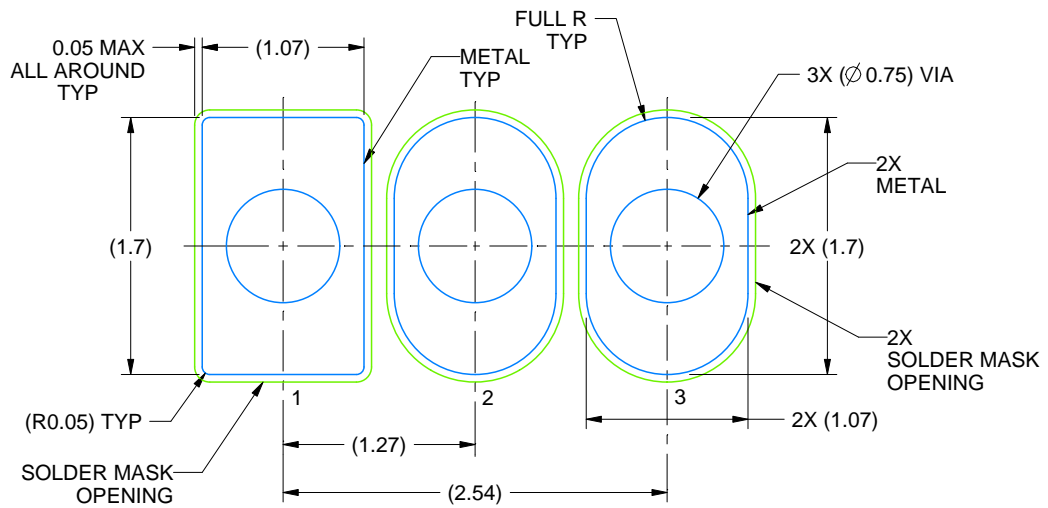

LAND PATTERN EXAMPLE
NON-SOLDER MASK DEFINED
SCALE:20X

4224358/A 06/2018

TAPE SPECIFICATIONS

LPE0003A

TO-92 - 5.05 mm max height

TRANSISTOR OUTLINE

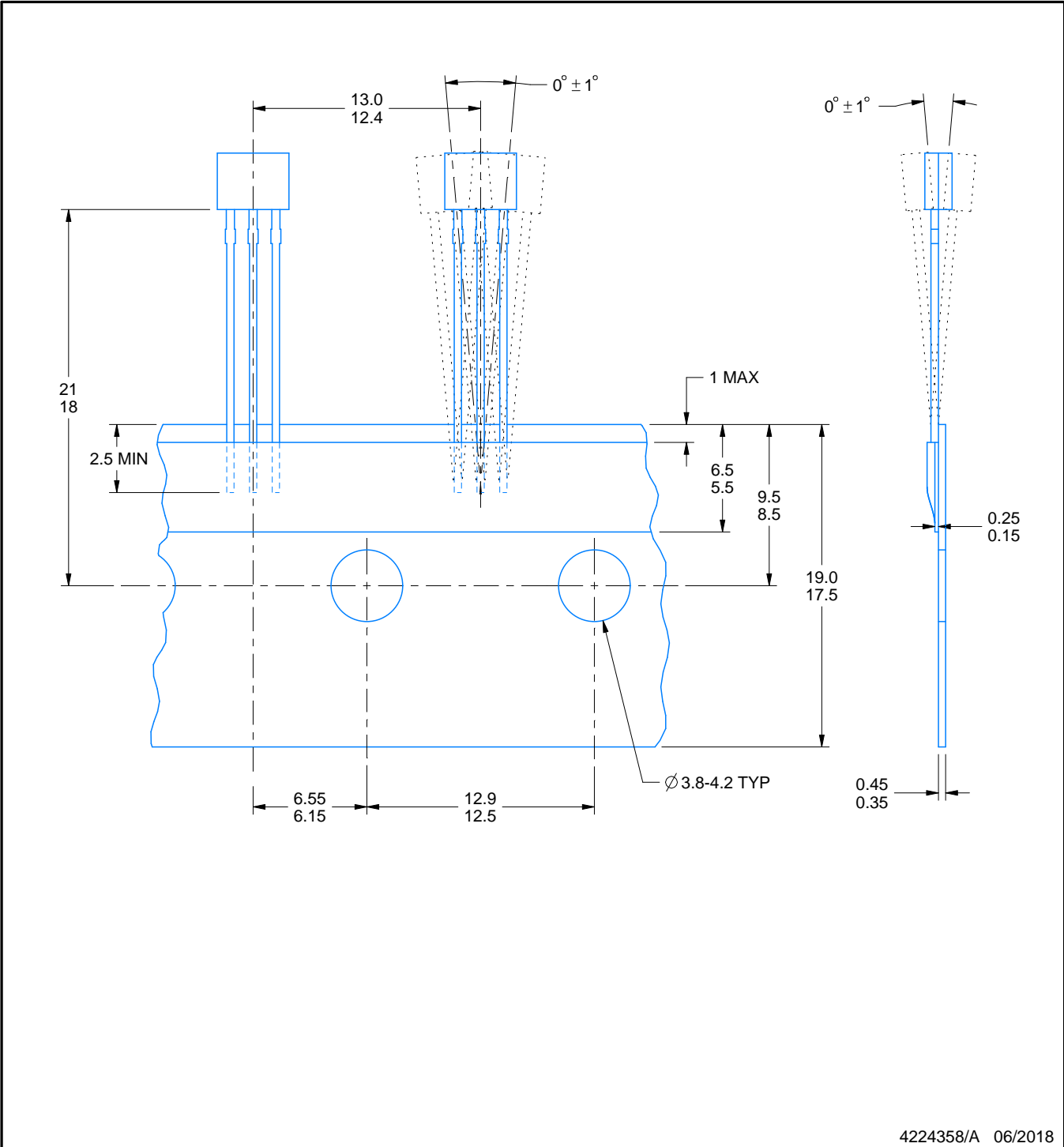

LPG0003A



PACKAGE OUTLINE

TO-92 - 5.05 mm max height

TRANSISTOR OUTLINE

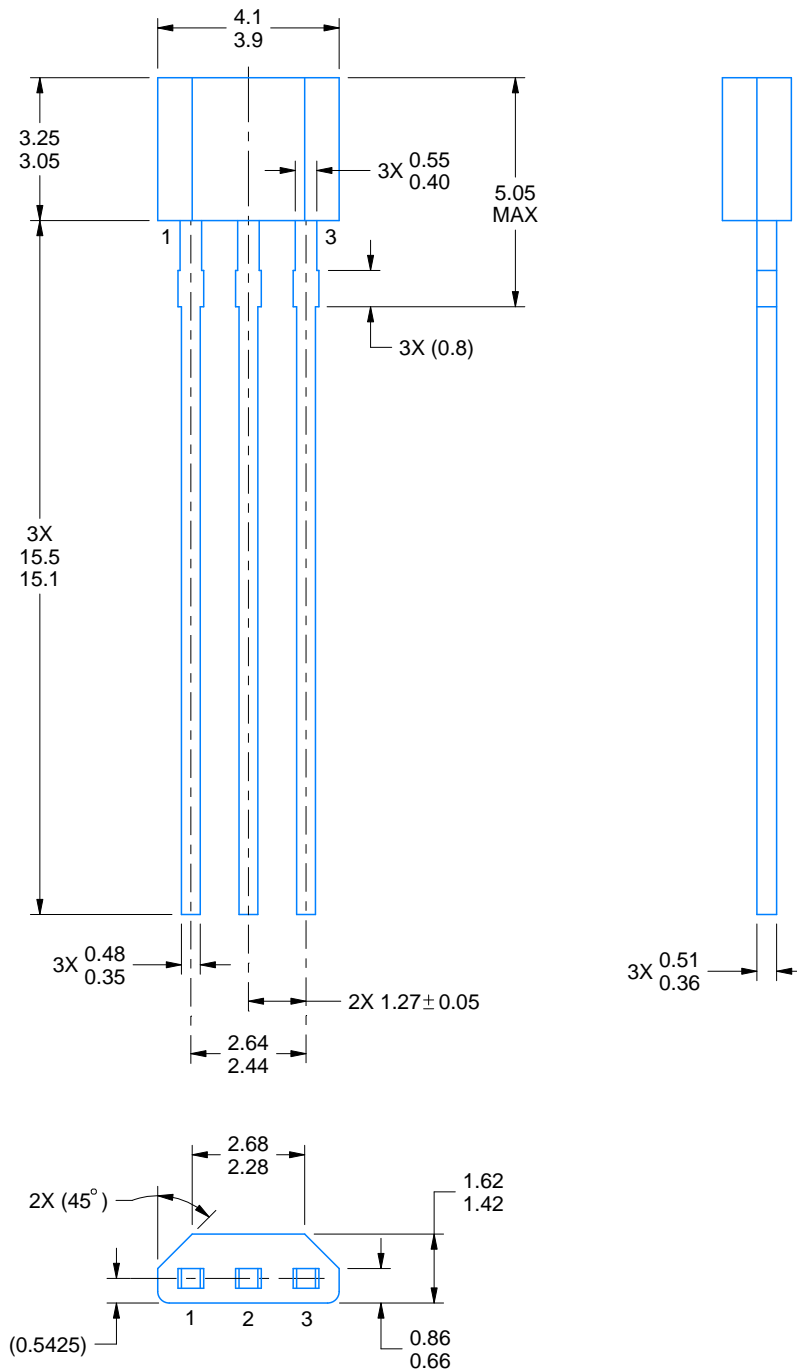

4221343/C 01/2018

NOTES:

1. All linear dimensions are in millimeters. Any dimensions in parenthesis are for reference only. Dimensioning and tolerancing per ASME Y14.5M.
2. This drawing is subject to change without notice.

EXAMPLE BOARD LAYOUT

LPG0003A

TO-92 - 5.05 mm max height

TRANSISTOR OUTLINE

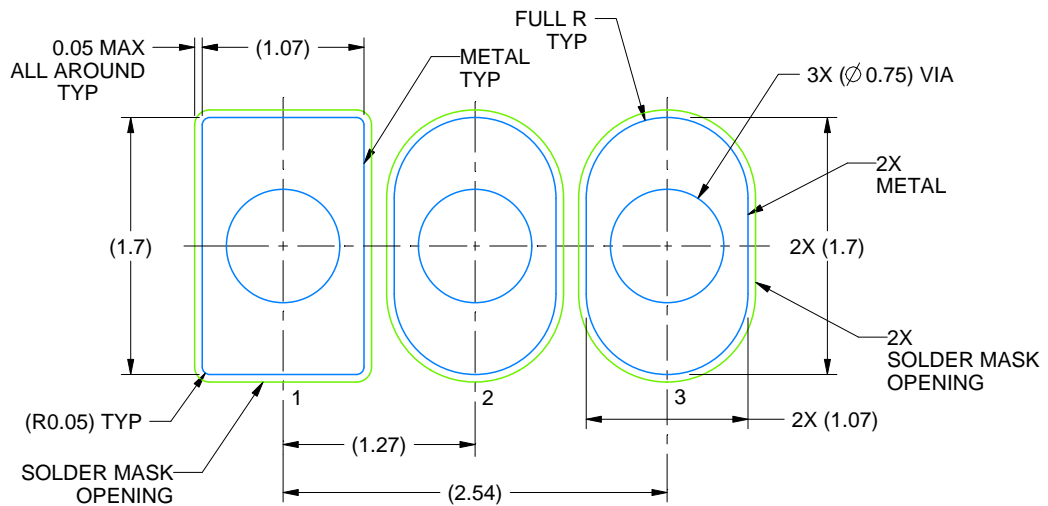

LAND PATTERN EXAMPLE
NON-SOLDER MASK DEFINED
SCALE:20X

4221343/C 01/2018

TAPE SPECIFICATIONS

LPG0003A

TO-92 - 5.05 mm max height

TRANSISTOR OUTLINE

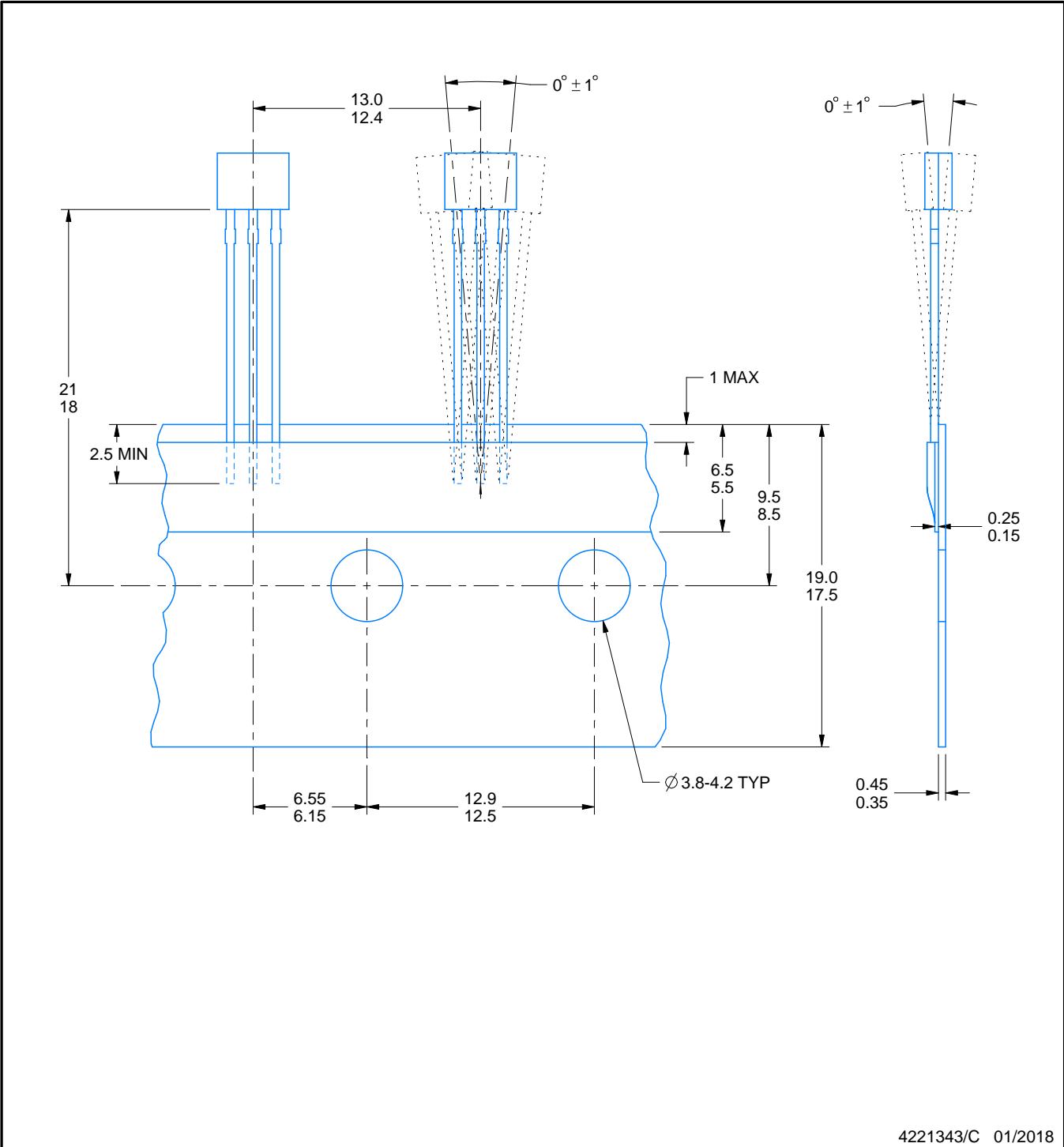

IMPORTANT NOTICE AND DISCLAIMER

TI PROVIDES TECHNICAL AND RELIABILITY DATA (INCLUDING DATA SHEETS), DESIGN RESOURCES (INCLUDING REFERENCE DESIGNS), APPLICATION OR OTHER DESIGN ADVICE, WEB TOOLS, SAFETY INFORMATION, AND OTHER RESOURCES "AS IS" AND WITH ALL FAULTS, AND DISCLAIMS ALL WARRANTIES, EXPRESS AND IMPLIED, INCLUDING WITHOUT LIMITATION ANY IMPLIED WARRANTIES OF MERCHANTABILITY, FITNESS FOR A PARTICULAR PURPOSE OR NON-INFRINGEMENT OF THIRD PARTY INTELLECTUAL PROPERTY RIGHTS.

These resources are intended for skilled developers designing with TI products. You are solely responsible for (1) selecting the appropriate TI products for your application, (2) designing, validating and testing your application, and (3) ensuring your application meets applicable standards, and any other safety, security, regulatory or other requirements.

These resources are subject to change without notice. TI grants you permission to use these resources only for development of an application that uses the TI products described in the resource. Other reproduction and display of these resources is prohibited. No license is granted to any other TI intellectual property right or to any third party intellectual property right. TI disclaims responsibility for, and you will fully indemnify TI and its representatives against, any claims, damages, costs, losses, and liabilities arising out of your use of these resources.

TI's products are provided subject to [TI's Terms of Sale](#) or other applicable terms available either on [ti.com](https://www.ti.com) or provided in conjunction with such TI products. TI's provision of these resources does not expand or otherwise alter TI's applicable warranties or warranty disclaimers for TI products.

TI objects to and rejects any additional or different terms you may have proposed.

Mailing Address: Texas Instruments, Post Office Box 655303, Dallas, Texas 75265
Copyright © 2025, Texas Instruments Incorporated