

LMG3100R017 100V, 97A GaN FET With Integrated Driver

1 Features

- Integrated 1.7mΩ GaN FET and driver
- Interated high-side level shift and bootstrap
- Two LGM3100 can form a half-bridge
 - No external level shifter needed
- 90V continuous, 100V pulsed voltage rating
- Package optimized for easy PCB layout
- 5V external bias power supply
- Supports 3.3V and 5V input logic levels
- High slew rate switching with low ringing
- Gate driver capable of up to 10MHz switching
- Internal bootstrap supply voltage clamping to prevent GaN FET overdrive
- Supply rail undervoltage lockout protection
- Excellent propagation delay (29.5ns typical) and matching (12ns typical)
- Low power consumption
- Exposed top QFN package for connection to heatsink

2 Applications

- Buck, boost, and buck-boost converters
- LLC converters
- [Solar inverters](#)
- [Telecom and server power](#)
- [Motor drives](#)
- [Power tools](#)
- [Class-D audio amplifiers](#)

3 Description

The LMG3100 device is a 90V, 97A Gallium Nitride (GaN) with integrated driver. The device consists of a 100V GaN FET driven by a high-frequency GaN FET driver. The LMG3100 incorporates a high side level shifter and bootstrap circuit, so that two LMG3100 devices can be used to form a half bridge without needing an additional level shifter.

GaN FETs provide significant advantages for power conversion as they have near zero reverse recovery and very small input capacitance C_{ISS} and output capacitance C_{OSS} . All the devices are mounted on a completely bond-wire free package platform with minimized package parasitic elements. The LMG3100 device is available in a 6.5mm × 4mm × 0.89mm lead-free package and can be easily mounted on PCBs.

The TTL logic compatible inputs can support 3.3V and 5V logic levels regardless of the VCC voltage. The proprietary bootstrap voltage clamping technique ensures the gate voltages of the enhancement mode GaN FETs are within a safe operating range.

The device extends advantages of discrete GaN FETs by offering a more user-friendly interface. It is an ideal solution for applications requiring high-frequency, high-efficiency operation in a small form factor.

Package Information

PART NUMBER	PACKAGE ⁽¹⁾	PACKAGE SIZE ⁽²⁾
LMG3100R017	VBE (VQFN, 15)	6.50mm × 4.0mm

- (1) For all available packages, see the orderable addendum at the end of the data sheet.
- (2) The package size (length × width) is a nominal value and includes pins, where applicable.

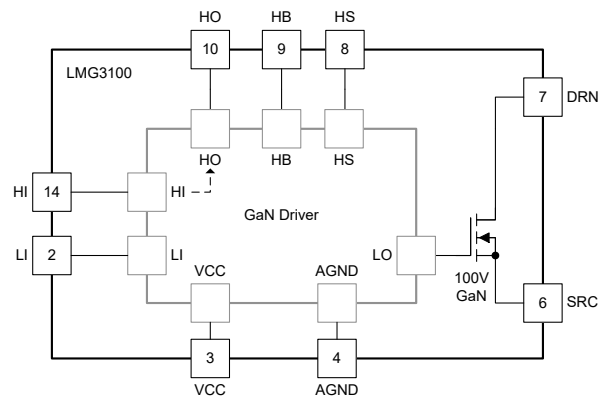

Simplified Block Diagram



Table of Contents

1 Features	1	8.2 Functional Block Diagram.....	10
2 Applications	1	8.3 Feature Description.....	11
3 Description	1	8.4 Device Functional Modes.....	13
4 Pin Configuration and Functions	3	9 Device and Documentation Support	20
5 Specifications	4	9.1 Documentation Support.....	20
5.1 Absolute Maximum Ratings.....	4	9.2 Receiving Notification of Documentation Updates....	20
5.2 ESD Ratings.....	4	9.3 Support Resources.....	20
5.3 Recommended Operating Conditions.....	4	9.4 Trademarks.....	20
5.4 Thermal Information	4	9.5 Electrostatic Discharge Caution.....	20
5.5 Electrical Characteristics.....	5	9.6 Glossary.....	20
6 Typical Characteristics	7	10 Revision History	20
7 Parameter Measurement Information	8	11 Mechanical, Packaging, and Orderable Information	21
7.1 Propagation Delay and Mismatch Measurement.....	8	11.1 Package Information.....	21
8 Detailed Description	10	11.2 Tape and Reel Information.....	25
8.1 Overview.....	10		

4 Pin Configuration and Functions

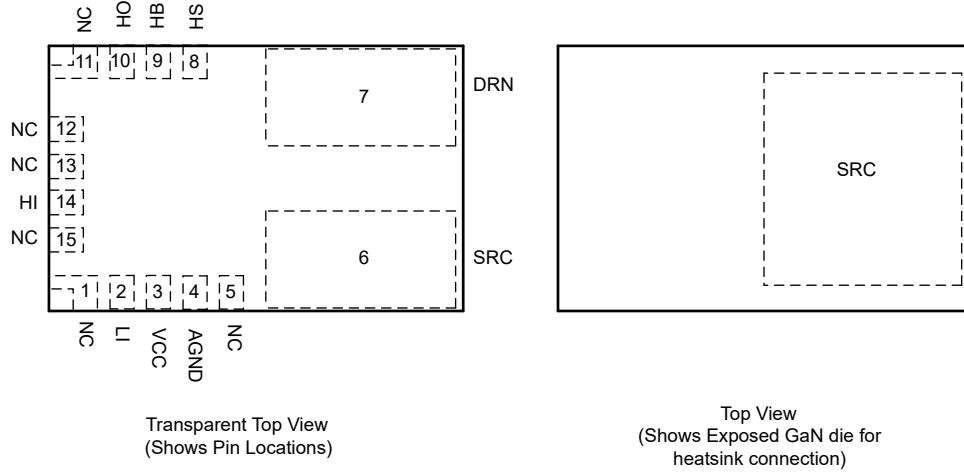

Figure 4-1. VBE Package, 15-Pin VQFN (Top View)

Table 4-1. Pin Functions

PIN		I/O ⁽¹⁾	DESCRIPTION
NAME	NO.		
NC	1, 5, 11–13, 15	—	Not connected internally. Leave floating.
LI	2	I	Low-side gate driver control input.
VCC	3	P	5V device power supply.
AGND	4	G	Analog ground.
SRC	6	I/O	Source of GaN FET. Internally connected to AGND.
DRN	7	I/O	Drain of GaN FET.
HS	8	P	Bootstrap voltage ground reference.
HB	9	P	High-side gate driver bootstrap rail with HS as the ground reference.
HO	10	O	Level shifted high-side gate driver control input.
HI	14	I	High-side gate driver control input.

(1) I = Input, O = Output, G = Ground, P = Power

5 Specifications

5.1 Absolute Maximum Ratings

over operating free-air temperature range (unless otherwise noted)⁽¹⁾

	MIN	MAX	UNIT
DRN to SRC	-5	100	V
DRN to SRC (pulsed, 100-ms max duration) ⁽²⁾		120	V
HB to AGND	-0.3	100	V
HS to AGND	-5	93	V
HI to AGND	-0.3	6	V
LI to AGND	-0.3	6	V
VCC to AGND	-0.3	6	V
HB to HS	-0.3	6	V
HB to VCC	0	93	V
IOOUT from DRN pin (Continuous), T _J = 25°C		97	A
IOOUT from DRN pin (Pulsed, 300 μs), T _J = 25°C		350	A
Junction Temperature, T _J	-40	150	°C
Storage Temperature, T _{stg}	-40	150	°C

- Operation outside the Absolute Maximum Ratings may cause permanent device damage. Absolute Maximum Ratings do not imply functional operation of the device at these or any other conditions beyond those listed under Recommended Operating Conditions. If used outside the Recommended Operating Conditions but within the Absolute Maximum Ratings, the device may not be fully functional, and this may affect device reliability, functionality, performance, and shorten the device lifetime.
- GaN FET can withstand 1000 pulses up to 120V of 100ms duration and less than 1% duty cycle over its lifetime.

5.2 ESD Ratings

		VALUE	UNIT	
V _(ESD)	Electrostatic Discharge	Human-body model (HBM), per ANSI/ESDA/ JEDEC JS-001 ⁽¹⁾	±500	V
		Charged-device model (CDM), per JEDEC specification JESD22-C101 ⁽²⁾	±500	V

- JEDEC document JEP155 states that 500-V HBM allows safe manufacturing with a standard ESD control process.
- JEDEC document JEP157 states that 250-V CDM allows safe manufacturing with a standard ESD control process.

5.3 Recommended Operating Conditions

over operating free-air temperature range (unless otherwise noted)

	MIN	NOM	MAX	UNIT
VCC	4.5	5	5.25	V
LI or HI Input	0		6	V
HS, DRN	-5		90	V

5.4 Thermal Information

THERMAL METRIC ⁽¹⁾		LMG2100	UNIT
		QFN	
		9 PINS	
R _{θJA}	Junction-to-ambient thermal resistance	36	°C/W
R _{θJC(top)}	Junction-to-case (top) thermal resistance	0.4	
R _{θJB}	Junction-to-board thermal resistance	3	°C/W
Ψ _{JT}	Junction-to-top characterization parameter	1.8	°C/W

5.4 Thermal Information (continued)

THERMAL METRIC ⁽¹⁾		LMG2100	UNIT
		QFN	
		9 PINS	
Ψ_{JB}	Junction-to-board characterization parameter	6	°C/W

(1) For more information about traditional and new thermal metrics, see the *IC Package Thermal Metrics* application report, [SPRA953](#).

5.5 Electrical Characteristics

over operating free-air temperature range (unless otherwise noted)⁽¹⁾

PARAMETER		TEST CONDITIONS	MIN	TYP	MAX	UNIT
SUPPLY CURRENTS						
I_{CC}	VCC Quiescent Current	LI = HI = 0V, VCC = 5V		0.08	0.125	mA
I_{CC}	VCC Quiescent Current	LI=VCC=5V, HI=0V		0.17	5	mA
I_{CCO}	Total VCC Operating Current	f = 500 kHz, 50% Duty cycle, $V_{IN} = 48V$		10	15.0	mA
I_{HB}	HB Quiescent Current	LI = HI = 0V, VCC = 5V, HB-HS = 4.6V		0.1	0.150	mA
I_{HB}	HB Quiescent Current	LI=0V, HI=VCC=5V, HB-HS=4.6V, $V_{IN}=48V$		0.16	0.25	mA
INPUT PINS						
V_{IH}	High-Level Input Voltage Threshold	Rising Edge	1.87	2.06	2.22	V
V_{IL}	Low-Level Input Voltage Threshold	Falling Edge	1.48	1.66	1.76	V
V_{HYS}	Hysteresis between rising and falling threshold			350		mV
R_I	Input pull down resistance		100	200	300	k Ω
OUTPUT PINS						
V_{OL}	Low level output voltage	$I_{OL} = 10$ mA			0.01	V
V_{OH}	High level output voltage	$I_{OL} = -10$ mA	$V_{HB}-0.03$			V
UNDER VOLTAGE PROTECTION						
V_{CCR}	VCC Rising edge threshold	Rising	3.2	3.8	4.5	V
V_{CCF}	VCC Falling edge threshold		3.0	3.6	4.3	V
$V_{CC(hyst)}$	VCC UVLO threshold hysteresis			217		mV
V_{HBR}	HB Rising edge threshold	Rising	2.5	3.2	3.9	V
V_{HBF}	HB Falling edge threshold		2.3	3.0	3.7	V
$V_{HB(hyst)}$	HB UVLO threshold hysteresis			224		mV
BOOTSTRAP DIODE						
V_{DL}	Low-Current forward voltage	$I_{VDD-HB} = 100\mu A$		0.45	0.65	V
V_{DH}	High current forward voltage	$I_{VDD-HB} = 100mA$		0.9	1.0	V
R_D	Dynamic Resistance	$I_{VDD-HB} = 100mA$		1.85		Ω
	HB-HS Clamp	Regulation Voltage	4.65	5	5.2	V
t_{BS}	Bootstrap diode reverse recovery time	$I_F = 100$ mA, $I_R = 100$ mA		40		ns
Q_{RR}	Bootstrap diode reverse recovery charge	$V_{VIN} = 50$ V		2		nC
POWER STAGE R017						
$R_{DS(ON)}$	GaN FET on-resistance	LI=VCC=5V, HI=0V, I(DRN-SRC)=30A, $T_J = 25^\circ C$		1.7	2.2	m Ω
V_{SD}	GaN 3rd quadrant conduction drop	$I_{SD} = 500$ mA, $V_{VCC} = 5$ V, HI = LI = 0V		1.5		V
$I_{L-DRN-SRC}$	Leakage from DRN to SRC when the GaN FET is off	DRN = 80V, HI = LI = 0V, $V_{VCC} = 5V$, $T_J=25^\circ C$		12	300	μA
C_{OSS}	Output Capacitance of GaN FET	$V_{DS}=50V$, $V_{GS}= 0V$ (HI = LI = 0V)		880	980	pF
$C_{OSS(ER)}$	Output Capacitance of GaN FET - Energy Related	$V_{DS}=0$ to 50V, $V_{GS}= 0V$ (HI = LI = 0V)		1058		pF
$C_{OSS(TR)}$	Output Capacitance of GaN FET - Time Related	$V_{DS}=0$ to 50V, $V_{GS}= 0V$ (HI = LI = 0V)		1422		pF
Q_G	Total Gate Charge of high side or low side HEMT	$V_{DS}=50V$, $I_D= 30A$, $V_{GS}= 5V$		20.3	29	nC

5.5 Electrical Characteristics (continued)

 over operating free-air temperature range (unless otherwise noted)⁽¹⁾

PARAMETER		TEST CONDITIONS	MIN	TYP	MAX	UNIT
Q _{GD}	Gate to Drain Charge of high side or low side HEMT	V _{DS} =50V, I _D = 16A		1.8		nC
Q _{GS}	Gate to Source Charge of high side or low side HEMT	V _{DS} =50V, I _D = 16A		6		nC
Q _{OSS}	Output Charge	V _{DS} =50V, I _D = 16A		76	88	nC
Q _{RR}	Source to Drain Reverse Recovery Charge	Not including internal driver bootstrap diode		0		nC
t _{HIPLH}	Propagation delay: HI Rising ⁽²⁾	LI=0V, VCC=5V, HB-HS=5V, VIN=48V		55	90	ns
t _{HIPHL}	Propagation delay: HI Falling ⁽²⁾	LI=0V, VCC=5V, HB-HS=5V, VIN=48V		55	90	ns
t _{LPLH}	Propagation delay: LI Rising ⁽²⁾	HI=0V, VCC=5V, HB-HS=5V, VIN=48V		29.5	50	ns
t _{LPHL}	Propagation delay: LI Falling ⁽²⁾	HI=0V, VCC=5V, HB-HS=5V, VIN=48V		29.5	50	ns
t _{MON}	Delay Matching: LI high & HI low ⁽²⁾			25	40	ns
t _{MOFF}	Delay Matching: LI low & HI high ⁽²⁾			25	40	ns
t _{PW}	Minimum Input Pulse Width that Changes the Output			10		ns

(1) Parameters that show only a typical value are determined by design and may not be tested in production

 (2) See *Propagation Delay and Mismatch Measurement* section

6 Typical Characteristics

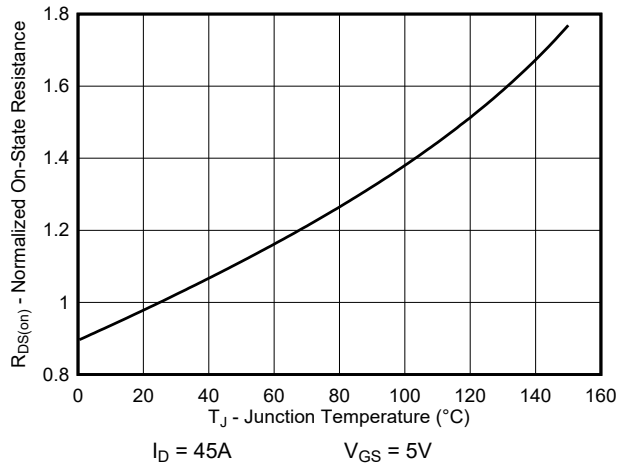

Figure 6-1. Normalized On-State Resistance vs Junction Temperature

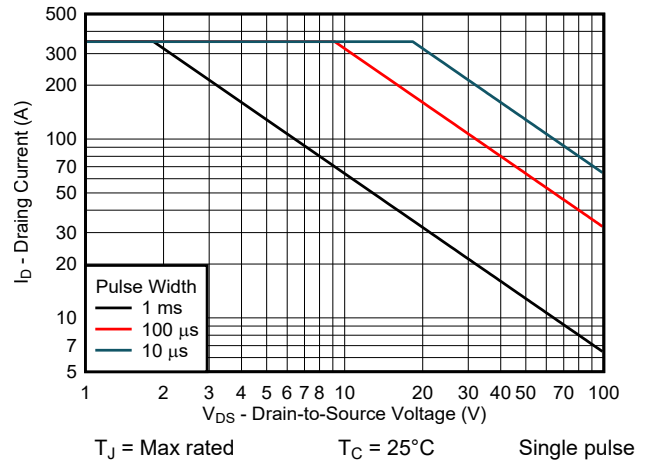

Figure 6-2. Safe Operating Area

7 Parameter Measurement Information

7.1 Propagation Delay and Mismatch Measurement

Figure 7-1 shows the typical test setup used to measure the propagation mismatch. As the gate drives are not accessible, pullup and pulldown resistors in this test circuit are used to indicate when the low-side GaN FET turns ON and the high-side GaN FET turns OFF and vice versa to measure the t_{MON} and t_{MOFF} parameters. Resistance values used in this circuit for the pullup and pulldown resistors are in the order of $1k\Omega$; the current sources used are 2A.

Figure 7-2 through Figure 7-5 show propagation delay measurement waveforms. For turnon propagation delay measurements, the current sources are not used. For turnoff time measurements, the current sources are set to 2A, and a voltage clamp limit is also set, referred to as $V_{IN(CLAMP)}$. When measuring the high-side component turnoff delay, the current source across the high-side FET is turned on, the current source across the low-side FET is off, HI transitions from high-to-low, and output voltage transitions from V_{IN} to $V_{IN(CLAMP)}$. Similarly, for low-side component turnoff propagation delay measurements, the high-side component current source is turned off, and the low-side component current source is turned on, LI transitions from high to low and the output change is the propagation delay time.

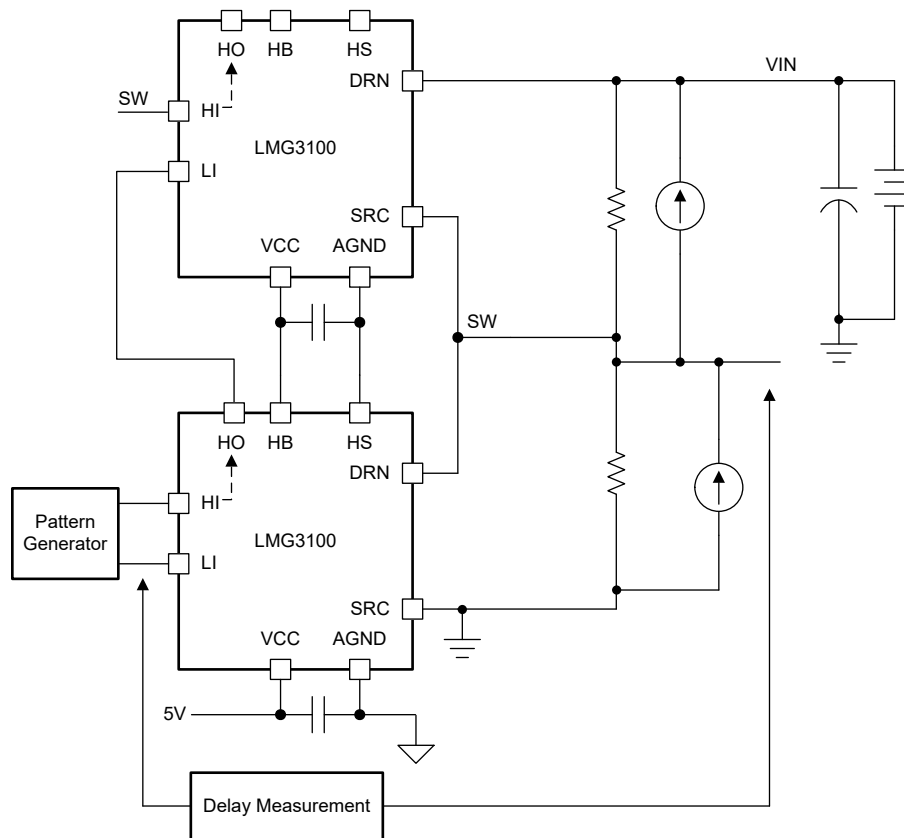

Figure 7-1. Propagation Delay and Propagation Mismatch Measurement

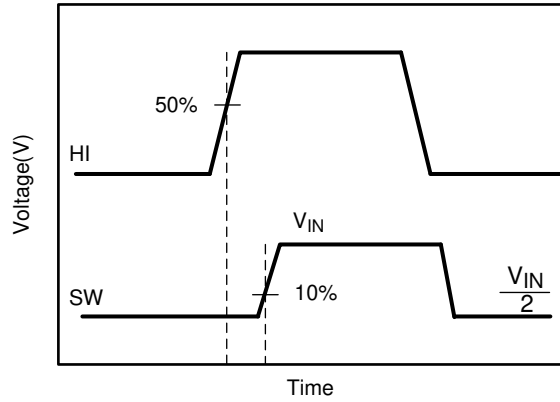

Figure 7-2. High-Side Gate Driver Turnon

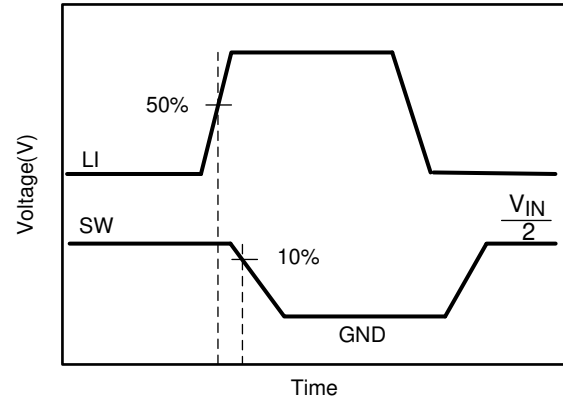

Figure 7-3. Low-Side Gate Driver Turnon

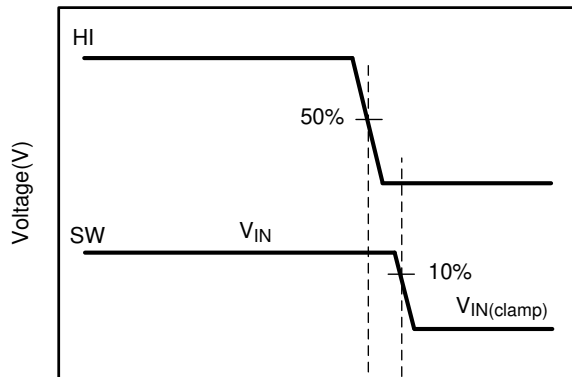

Figure 7-4. High-Side Gate Driver Turnoff

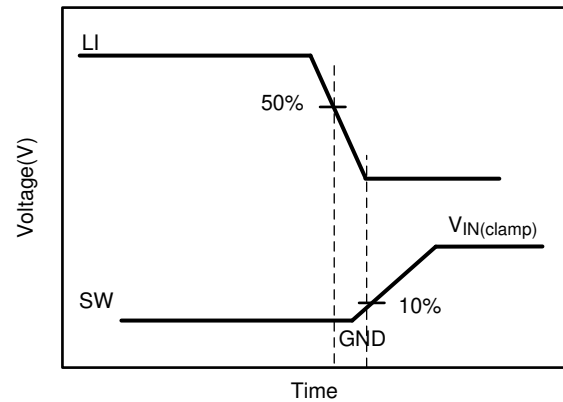

Figure 7-5. Low-Side Gate Driver Turnoff

8 Detailed Description

8.1 Overview

Section 8.2 shows the LMG3100 GaN FET with gate driver, high-side level shift and bootstrap circuit, which includes built-in UVLO protection circuitry and an overvoltage clamp circuitry. The clamp circuitry limits the bootstrap refresh operation to ensure that the high-side gate driver overdrive does not exceed 5.4V. The device integrates a 1.7mΩ GaN FET, with the possibility of using two LMG3100 to form a half-bridge without external level shifter. The device can be used in many isolated and non-isolated topologies allowing very simple integration. The drive strengths for turnon and turnoff are optimized to ensure high voltage slew rates without causing any excessive ringing on the gate or power loop.

8.2 Functional Block Diagram

The functional block diagram of the LMG3100 device with integrated GaN FET and driver, high-side level shift, and bootstrap circuit.

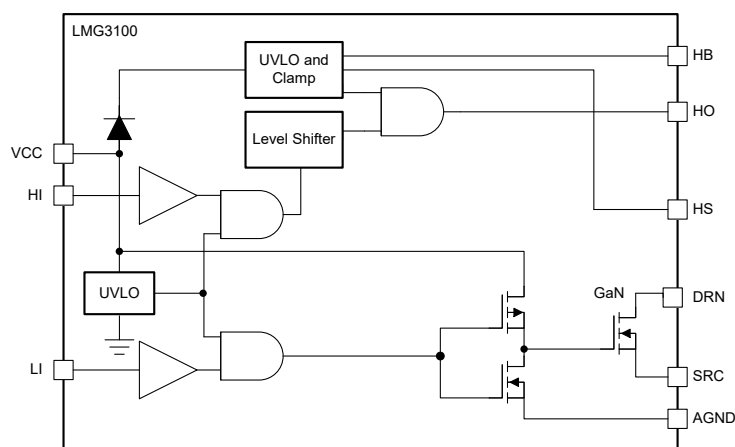

8.3 Feature Description

The LMG3100 device brings ease of designing high power density boards without the need for underfill while maintaining creepage and clearance requirements. The propagation delays between the high-side gate driver and low-side gate driver are matched to allow very tight control of dead time. Controlling the dead time is critical in GaN-based applications to maintain high efficiency. HI and LI can be independently controlled to minimize the third quadrant conduction of the low-side FET for hard switched buck converters. A very small propagation mismatch between the HI and LI to the drivers for both the falling and rising thresholds ensures dead times of < 20 ns. Co-packaging the GaN FET half-bridge with the driver ensures minimized common source inductance. This minimized inductance has a significant performance impact on hard-switched topologies.

The built-in bootstrap circuit with clamp prevents the high-side gate drive from exceeding the GaN FETs maximum gate-to-source voltage (V_{gs}) without any additional external circuitry. The built-in driver has an undervoltage lockout (UVLO) on the VDD and bootstrap (HB-HS) rails. When the voltage is below the UVLO threshold voltage, the device ignores both the HI and LI signals to prevent the GaN FETs from being partially turned on. Below UVLO, if there is sufficient voltage ($V_{VCC} > 2.5\text{ V}$), the driver actively pulls the high-side and low-side gate driver output low. The UVLO threshold hysteresis of 200 mV prevents chattering and unwanted turnon due to voltage spikes. Use an external VCC bypass capacitor with a value of 1 μF or higher. TI recommends a size of 0402 to minimize trace length to the pin. Place the bypass and bootstrap capacitors as close as possible to the device to minimize parasitic inductance.

8.3.1 Control Inputs

The LMG3100's inputs pins are independently controlled with TTL input thresholds and can support 3.3-V and 5-V logic levels regardless of the VCC voltage.

In order to allow flexibility to optimize deadtime according to design needs, the LMG3100 does not implement an overlap protection functionality. If both HI and LI are asserted, both the high-side and low-side GaN FETs are turned on. Careful consideration must be applied to the control inputs in order to avoid a shoot-through condition.

8.3.2 Start-up and UVLO

The LMG3100 has an UVLO on both the V_{CC} and HB (bootstrap) supplies. When the V_{CC} voltage is below the threshold voltage of 3.8 V, both the HI and LI inputs are ignored, to prevent the GaN FETs from being partially turned on. Also, if there is insufficient V_{CC} voltage, the UVLO actively pulls the high- and low-side GaN FET gates low. When the HB to HS bootstrap voltage is below the UVLO threshold of 3.2 V, only the high-side GaN FET gate is pulled low. Both UVLO threshold voltages have 200 mV of hysteresis to avoid chattering.

Table 8-1. V_{CC} UVLO Feature Logic Operation

CONDITION ($V_{HB-HS} > V_{HBR}$ for all cases below)	HI	LI	SW
$V_{CC} - V_{SS} < V_{CCR}$ during device start-up	H	L	Hi-Z
$V_{CC} - V_{SS} < V_{CCR}$ during device start-up	L	H	Hi-Z
$V_{CC} - V_{SS} < V_{CCR}$ during device start-up	H	H	Hi-Z
$V_{CC} - V_{SS} < V_{CCR}$ during device start-up	L	L	Hi-Z
$V_{CC} - V_{SS} < V_{CCR} - V_{CC(hyst)}$ after device start-up	H	L	Hi-Z
$V_{CC} - V_{SS} < V_{CCR} - V_{CC(hyst)}$ after device start-up	L	H	Hi-Z
$V_{CC} - V_{SS} < V_{CCR} - V_{CC(hyst)}$ after device start-up	H	H	Hi-Z
$V_{CC} - V_{SS} < V_{CCR} - V_{CC(hyst)}$ after device start-up	L	L	Hi-Z

Table 8-2. V_{HB-HS} UVLO Feature Logic Operation

CONDITION ($V_{CC} > V_{CCR}$ for all cases below)	HI	LI	SW
$V_{HB-HS} < V_{HBR}$ during device start-up	H	L	Hi-Z
$V_{HB-HS} < V_{HBR}$ during device start-up	L	H	PGND
$V_{HB-HS} < V_{HBR}$ during device start-up	H	H	PGND
$V_{HB-HS} < V_{HBR}$ during device start-up	L	L	Hi-Z
$V_{HB-HS} < V_{HBR} - V_{HB(hyst)}$ after device start-up	H	L	Hi-Z

Table 8-2. V_{HB-HS} UVLO Feature Logic Operation (continued)

CONDITION ($V_{CC} > V_{CCR}$ for all cases below)	HI	LI	SW
$V_{HB-HS} < V_{HBR} - V_{HB(hyst)}$ after device start-up	L	H	PGND
$V_{HB-HS} < V_{HBR} - V_{HB(hyst)}$ after device start-up	H	H	PGND
$V_{HB-HS} < V_{HBR} - V_{HB(hyst)}$ after device start-up	L	L	Hi-Z

8.3.3 Bootstrap Supply Voltage Clamping

The high-side bias voltage is generated using a bootstrap technique and is internally clamped at 5 V (typical). This clamp prevents the gate voltage from exceeding the maximum gate-source voltage rating of the enhancement-mode GaN FETs.

8.3.4 Level Shift

The level-shift circuit is the interface from the high-side input HI to the high-side driver stage, which is referenced to the switch node (HS). The level shift allows control of the high-side GaN FET gate driver output, which is referenced to the HS pin and provides excellent delay matching with the low-side driver.

8.4 Device Functional Modes

The LMG3100 operates in normal mode and UVLO mode. See [Section 8.3.2](#) for information on UVLO operation mode. In the normal mode, the output state is dependent on the states of the HI and LI pins. [Table 8-3](#) lists the output states for different input pin combinations. Note that when both HI and LI are asserted, both GaN FETs in the power stage are turned on. Careful consideration must be applied to the control inputs in order to avoid this state, as it will result in a shoot-through condition, which can permanently damage the device.

Table 8-3. Truth Table

HI	LI	HIGH-SIDE GaN FET	LOW-SIDE GaN FET	SW
L	L	OFF	OFF	Hi-Z
L	H	OFF	ON	PGND
H	L	ON	OFF	VIN
H	H	ON	ON	---

Application and Implementation

Note

Information in the following applications sections is not part of the TI component specification, and TI does not warrant its accuracy or completeness. TI's customers are responsible for determining suitability of components for their purposes. Customers should validate and test their design implementation to confirm system functionality.

9.1 Application Information

The LMG3100 GaN power stage is a versatile building block for various types of high-frequency, switch-mode power applications. The high-performance gate driver IC integrated in the package helps minimize the parasitics and results in extremely fast switching of the GaN FETs. The device design is highly optimized for synchronous buck converters and other half-bridge configurations.

9.2 Typical Application

[Figure 9-1](#) shows a synchronous buck converter application using a digital PWM controller. The control signal for the high-side LMG3100 provided by the digital controller is level shifted through the low-side LMG3100, to complete the half-bridge without using an additional level shifter. It is critical to optimize the power loop (loop impedance from VIN capacitor to PGND). Having a high power loop inductance causes significant ringing in the SW node and also causes the associated power loss.

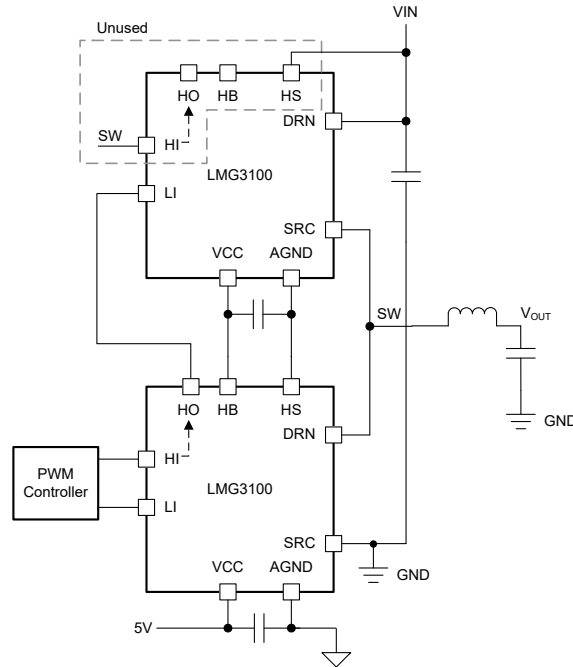

Figure 9-1. Typical Connection Diagram For a Synchronous Buck Converter

9.2.1 Design Requirements

When designing a synchronous buck converter application that incorporates the LMG3100 power stage, some design considerations must be evaluated first to make the most appropriate selection. Among these considerations are the input voltages, passive components, operating frequency, and controller selection. [Table 9-1](#) shows some sample values for a typical application. See [Section Power Supply Recommendations](#), [Section 9.3](#), and [Section 9.2.2.5](#) for other key design considerations for the LMG3100.

Table 9-1. Design Parameters

PARAMETER	SAMPLE VALUE
Half-bridge input supply voltage, V_{IN}	48 V
Output voltage, V_{OUT}	12 V
Output current	8 A
V_{HB-HS} bootstrap capacitor	0.3 μ F, X5R
Switching frequency	1 MHz
Dead time	8 ns
Inductor	4.7 μ H
Controller	LM5148

9.2.2 Detailed Design Procedure

This procedure outlines the design considerations of LMG3100 in a synchronous buck converter. For additional design help, see [Section 9.1.1](#).

9.2.2.1 V_{CC} Bypass Capacitor

The V_{CC} bypass capacitor provides the gate charge for the low-side and high-side transistors and to absorb the reverse recovery charge of the bootstrap diode. The required bypass capacitance can be calculated with [Equation 1](#).

$$C_{VCC} = (2 \times Q_G + Q_{RR}) / \Delta V \quad (1)$$

Q_G is the individual and equal gate charge of the high-side and low-side GaN FETs. Q_{RR} is the reverse recovery charge of the bootstrap diode. ΔV is the maximum allowable voltage drop across the bypass capacitor. A 1- μF or larger value, good-quality, ceramic capacitor is recommended. Place the bypass capacitor as close as possible to the V_{CC} and AGND pins of the device to minimize the parasitic inductance.

9.2.2.2 Bootstrap Capacitor

The bootstrap capacitor provides the gate charge for the high-side gate drive, dc bias power for HB UVLO circuit, and the reverse recovery charge of the bootstrap diode. The required bypass capacitance can be calculated using Equation 2.

$$C_{BST} = (Q_G + Q_{RR} + I_{CC} * t_{ON(max)}) / \Delta V \quad (2)$$

where

- I_{CC} is the quiescent current of the high side device
- $t_{ON(max)}$ is the maximum on-time period of the high-side gate driver
- Q_{RR} is the reverse recovery charge of the bootstrap diode
- Q_G is the gate charge of the high-side GaN FET
- ΔV is the permissible ripple in the bootstrap capacitor (< 100 mV, typical)

A 0.3- μF , 16-V, 0402 ceramic capacitor is suitable for most applications. Place the bootstrap capacitor as close as possible to the HB and HS pins.

9.2.2.3 Slew Rate Control

Figure 9-2 shows a switching application where the slew rate on the switch node may be controlled by using resistors R_{VCCL} and R_{VCCH} . R_{VCCL} may be used to slow down the turn-on of the Low Side GaN FET (for example, in a buck converter), and R_{VCCH} may be used to slow down the turn-on of the High Side GaN FET (for example, in a boost converter). Using these resistors allows the system engineer to optimize the tradeoff between higher efficiency (faster slew rates) and lower ringing (slower slew rates).

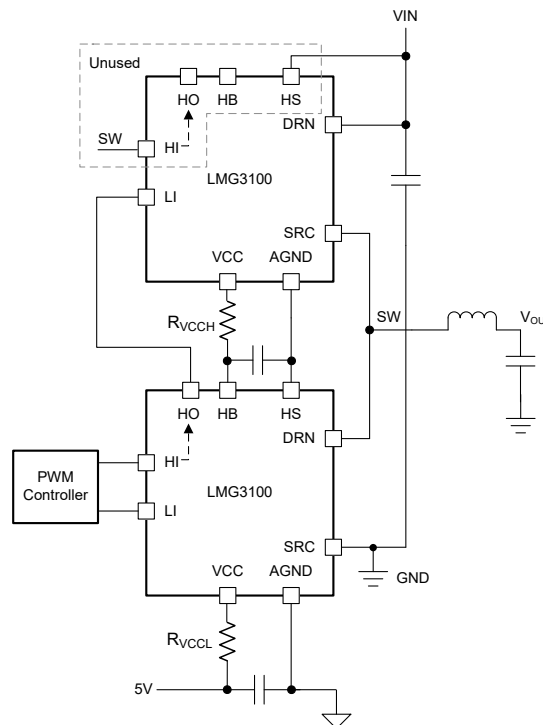

Figure 9-2. Slew Rate Control with R_{VCCL} and R_{VCCH} Resistors

9.2.2.4 Use With Analog Controllers

Figure 9-3 shows a synchronous buck converter application using an analog controller that provides level-shifted high-side control with the switch node as reference. The analog controller also generates the bootstrap voltage. In this use case, the level-shifted high-side control output, HO, from the controller may be directly connected to the input pin, LI, of the high-side LMG3100. The in-built level shifter and boot-strap circuits of the low-side LMG3100 are left unused.

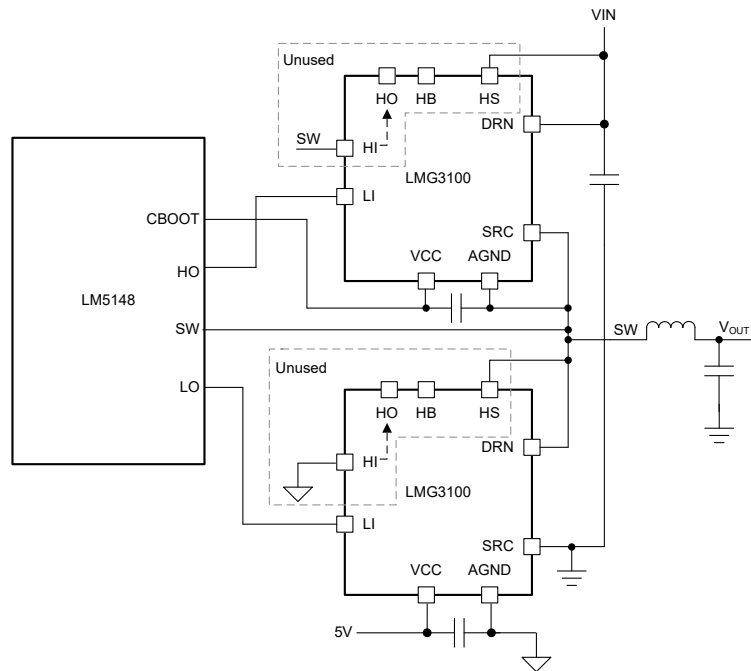

Figure 9-3. Use With Analog Controllers That Have In-built Level-shifting

9.2.2.5 Power Dissipation

Ensure that the power loss in the driver and the GaN FETs is maintained below the maximum power dissipation limit of the package at the operating temperature. The smaller the power loss in the driver and the GaN FETs, the higher the maximum operating frequency that can be achieved in the application. The total power dissipation of the LMG3100 device is the sum of the gate driver losses, the bootstrap diode power loss and the switching and conduction losses in the FETs.

The gate driver losses are incurred by charge and discharge of the capacitive load. It can be approximated using [Equation 3](#).

$$P = 2 \times Q_G \times V_{CC} \times f_{SW} \quad (3)$$

where

- Q_G is the gate charge
- V_{CC} is the bias supply
- f_{SW} is the switching frequency

There are some additional losses in the gate drivers due to the internal CMOS stages used to buffer the outputs.

The bootstrap diode power loss is the sum of the forward bias power loss that occurs while charging the bootstrap capacitor and the reverse bias power loss that occurs during reverse recovery. Because each of these events happens once per cycle, the diode power loss is proportional to the operating frequency. Higher input voltages (V_{IN}) to the half bridge also result in higher reverse recovery losses.

The power losses due to the GaN FETs can be divided into conduction losses and switching losses. Conduction losses are resistive losses and can be calculated using [Equation 4](#).

$$P_{COND} = \left[(I_{RMS(HS)})^2 \times R_{DS(on)HS} \right] + \left[(I_{RMS(LS)})^2 \times R_{DS(on)LS} \right] \quad (4)$$

where

- $R_{DS(on)HS}$ is the high-side GaN FET on-resistance
- $R_{DS(on)LS}$ is the low-side GaN FET on-resistance
- $I_{RMS(HS)}$ is the high-side GaN FET RMS current
- $I_{RMS(LS)}$ and low-side GaN FET RMS current

The switching losses can be computed to a first order using t_{TR} can be approximated by dividing V_{IN} by 25V/ns, which is a conservative estimate of the switched node slew rate. [Equation 5](#).

$$P_{SW} = V_{IN} \times I_{OUT} \times t_{TR} \times f_{SW} + V_{IN} \times V_{IN} \times C_{OSS(ER)} \times f_{SW} \quad (5)$$

where

- t_{TR} is sum of the switch node transition times from ON to OFF and from OFF to ON
- $C_{OSS(ER)}$ is the output capacitance of each GaN FET

Note that the low-side FET does not suffer from this loss. The third quadrant loss in the low-side device is ignored in this first order loss calculation.

As described previously, switching frequency has a direct effect on device power dissipation. Although the gate driver of the LMG3100 device is capable of driving the GaN FETs at frequencies up to 10MHz, careful consideration must be applied to ensure that the running conditions for the device meet the recommended operating temperature specification. Specifically, hard-switched topologies tend to generate more losses and self-heating than soft-switched applications.

The sum of the driver loss, the bootstrap diode loss, and the switching and conduction losses in the GaN FETs is the total power loss of the device. Careful board layout with an adequate amount of thermal vias close to the

power pads (VIN and PGND) allows optimum power dissipation from the package. A top-side mounted heat sink with airflow can also improve the package power dissipation.

Power Supply Recommendations

The recommended bias supply voltage range for LMG3100 is from 4.75 V to 5.25 V. The lower end of this range is governed by the internal undervoltage lockout (UVLO) protection feature of the V_{CC} supply circuit. The upper end of this range is driven by the 6 V absolute maximum voltage rating of V_{CC} . Note that the gate voltage of the low-side GaN FET is not clamped internally. Hence, it is important to keep the V_{CC} bias supply within the recommended operating range to prevent exceeding the low-side GaN transistor gate breakdown voltage.

The UVLO protection feature also involves a hysteresis function. This means that once the device is operating in normal mode, if the V_{CC} voltage drops, the device continues to operate in normal mode as far as the voltage drop does not exceeds the hysteresis specification, $V_{CC(hyst)}$. If the voltage drop is more than hysteresis specification, the device shuts down. Therefore, while operating at or near the 4.5 V range, the voltage ripple on the auxiliary power supply output must be smaller than the hysteresis specification of LMG3100 to avoid triggering device-shutdown.

Place a local bypass capacitor between the VDD and VSS pins. This capacitor must be located as close as possible to the device. A low ESR, ceramic surface-mount capacitor is recommended. TI recommends using 2 capacitors across VDD and GND: a 100 nF ceramic surface-mount capacitor for high frequency filtering placed very close to VDD and GND pin, and another surface-mount capacitor, 220 nF to 10 μ F, for IC bias requirements.

9.3 Layout

9.3.1 Layout Guidelines

To maximize the efficiency benefits of fast switching, it is extremely important to optimize the board layout such that the power loop impedance is minimal. When using a multilayer board (more than 2 layers), power loop parasitic impedance is minimized by having the return path to the input capacitor (between VIN and PGND), small and directly underneath the first layer as shown in [Figure 9-4](#) and [Figure 9-5](#). Loop inductance is reduced due to flux cancellation as the return current is directly underneath and flowing in the opposite direction.

Insufficient attention to the above power loop layout guidelines can result in excessive overshoot and undershoot on the switch node.

It is also critical that the VCC capacitors and the bootstrap capacitors are as close as possible to the device and in the first layer. Carefully consider the AGND connection of LMG3100 device. It must NOT be directly connected to PGND so that PGND noise does not directly shift AGND and cause spurious switching events due to noise injected in HI and LI signals.

9.3.2 Layout Examples

Placements shown in [Figure 9-4](#) and in the cross section of [Figure 9-5](#) show the suggested placement of the device with respect to sensitive passive components, such as VIN, bootstrap capacitors (HS and HB) and VSS capacitors. Use appropriate spacing in the layout to reduce creepage and maintain clearance requirements in accordance with the application pollution level. Inner layers if present can be more closely spaced due to negligible pollution.

The layout must be designed to minimize the capacitance at the SW node. Use as small an area of copper as possible to connect the device SW pin to the inductor, or transformer, or other output load. Furthermore, ensure that the ground plane or any other copper plane has a cutout so that there is no overlap with the SW node, as this would effectively form a capacitor on the printed circuit board. Additional capacitance on this node reduces the advantages of the advanced packaging approach of the LMG3100 and may result in reduced performance.

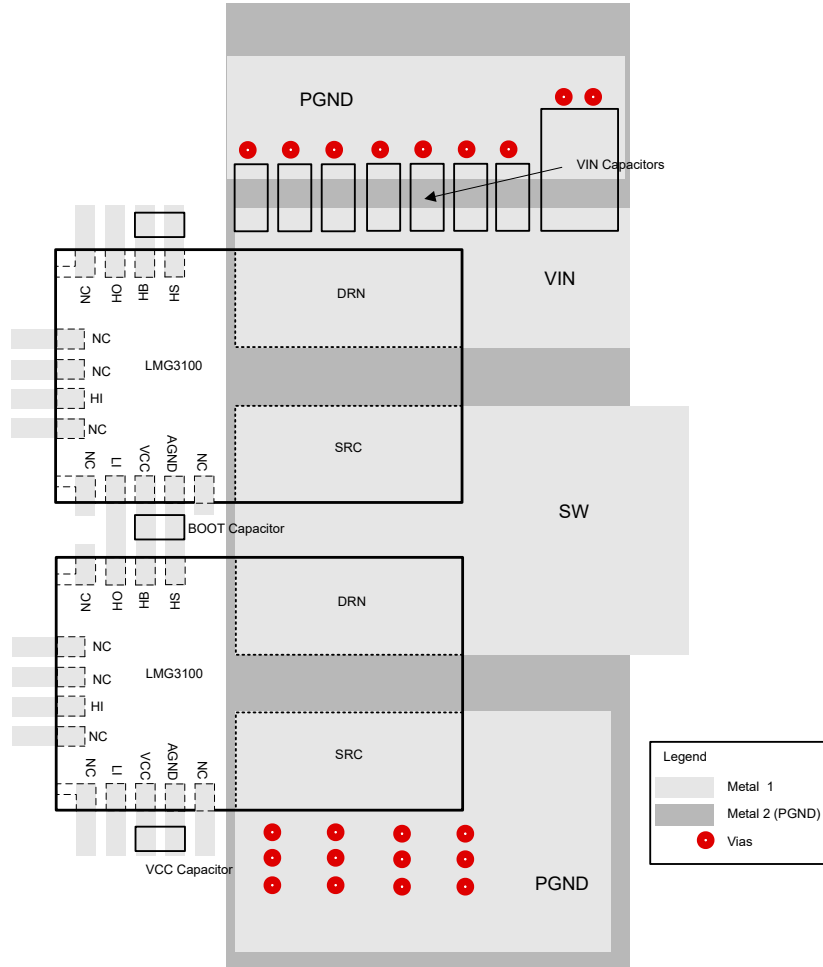

Figure 9-4. External Component Placement (Multi Layer Board)

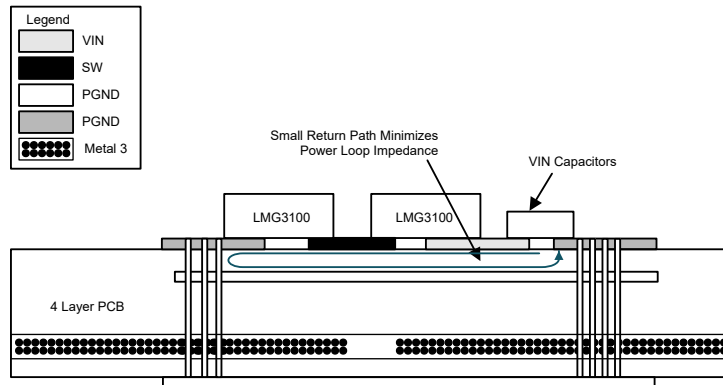

Figure 9-5. Four-Layer Board Cross Section With Return Path Directly Underneath for Power Loop

ADVANCE INFORMATION

9 Device and Documentation Support

9.1 Documentation Support

9.1.1 Related Documentation

[Layout Guidelines for LMG3100 GaN Power Stage Module](#)

[Using the LMG3100: GaN Half-Bridge Power Module Evaluation Module](#)

9.2 Receiving Notification of Documentation Updates

To receive notification of documentation updates, navigate to the device product folder on ti.com. Click on *Notifications* to register and receive a weekly digest of any product information that has changed. For change details, review the revision history included in any revised document.

9.3 Support Resources

[TI E2E™ support forums](#) are an engineer's go-to source for fast, verified answers and design help — straight from the experts. Search existing answers or ask your own question to get the quick design help you need.

Linked content is provided "AS IS" by the respective contributors. They do not constitute TI specifications and do not necessarily reflect TI's views; see TI's [Terms of Use](#).

9.4 Trademarks

TI E2E™ is a trademark of Texas Instruments.

All trademarks are the property of their respective owners.

9.5 Electrostatic Discharge Caution



This integrated circuit can be damaged by ESD. Texas Instruments recommends that all integrated circuits be handled with appropriate precautions. Failure to observe proper handling and installation procedures can cause damage.

ESD damage can range from subtle performance degradation to complete device failure. Precision integrated circuits may be more susceptible to damage because very small parametric changes could cause the device not to meet its published specifications.

9.6 Glossary

[TI Glossary](#) This glossary lists and explains terms, acronyms, and definitions.

10 Revision History

NOTE: Page numbers for previous revisions may differ from page numbers in the current version.

DATE	REVISION	NOTES
January 2024	*	Initial Release

11 Mechanical, Packaging, and Orderable Information

The following pages include mechanical, packaging, and orderable information. This information is the most current data available for the designated devices. This data is subject to change without notice and revision of this document. For browser-based versions of this data sheet, refer to the left-hand navigation.

11.1 Package Information

The LMG3100 device package is rated as an MSL3 package (Moisture Sensitivity Level 3). Refer to application report [AN-2029 Handling and Process Recommendations](#) for specific handling and process recommendations of an MSL3 package.

EXAMPLE BOARD LAYOUT

VBE0015A

VQFN-FCRLF - 0.85 mm max height

PLASTIC QUAD FLATPACK - NO LEAD

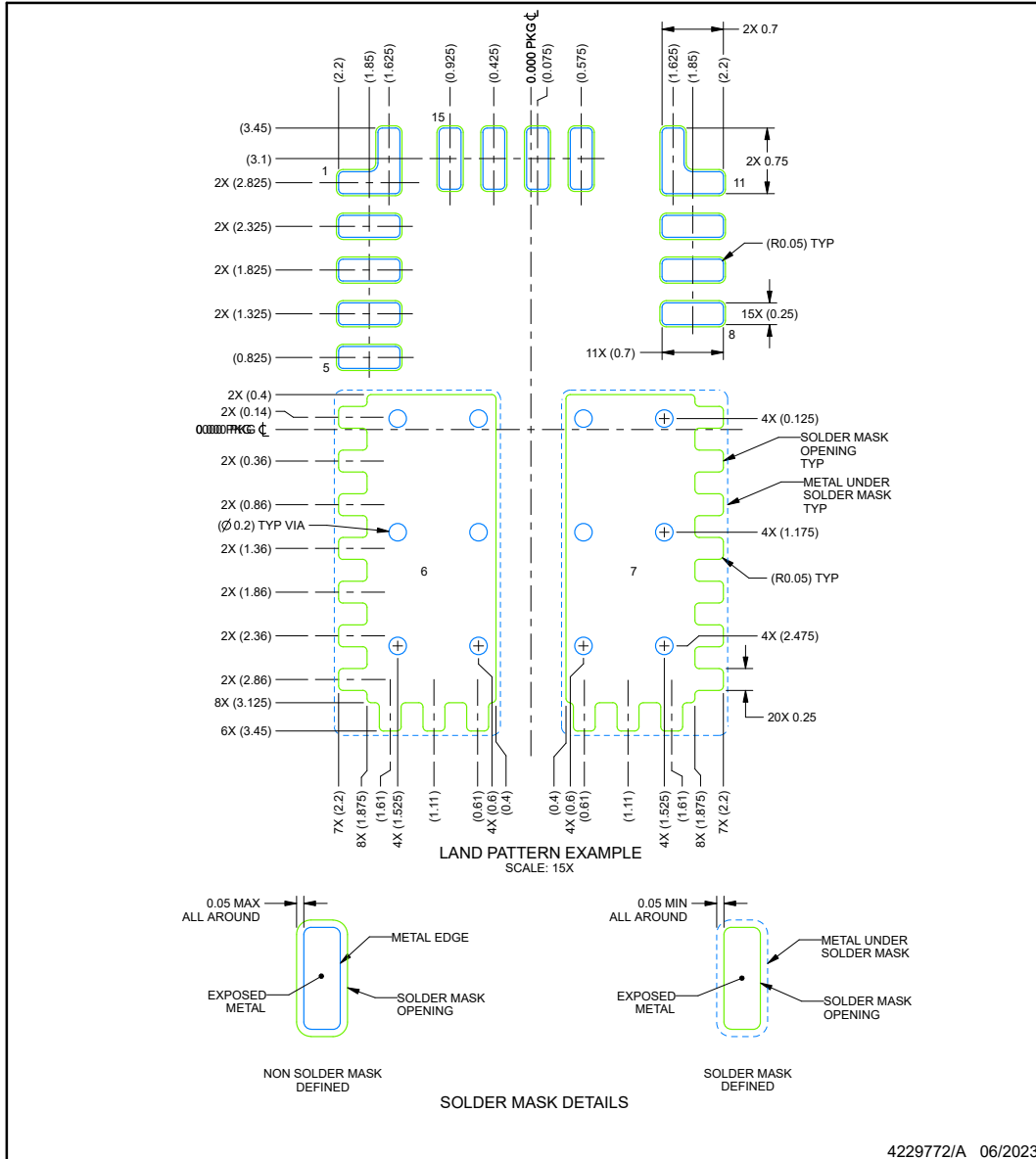

NOTES: (continued)

- 4. This package is designed to be soldered to a thermal pad on the board. For more information, see Texas Instruments literature number SLUA271 (www.ti.com/lit/slua271).
- 5. Vias are optional depending on application, refer to device data sheet. If any vias are implemented, refer to their locations shown on this view. It is recommended that vias under paste be filled, plugged or tented.

EXAMPLE STENCIL DESIGN

VBE0015A

VQFN-FCRLF - 0.85 mm max height

PLASTIC QUAD FLATPACK - NO LEAD

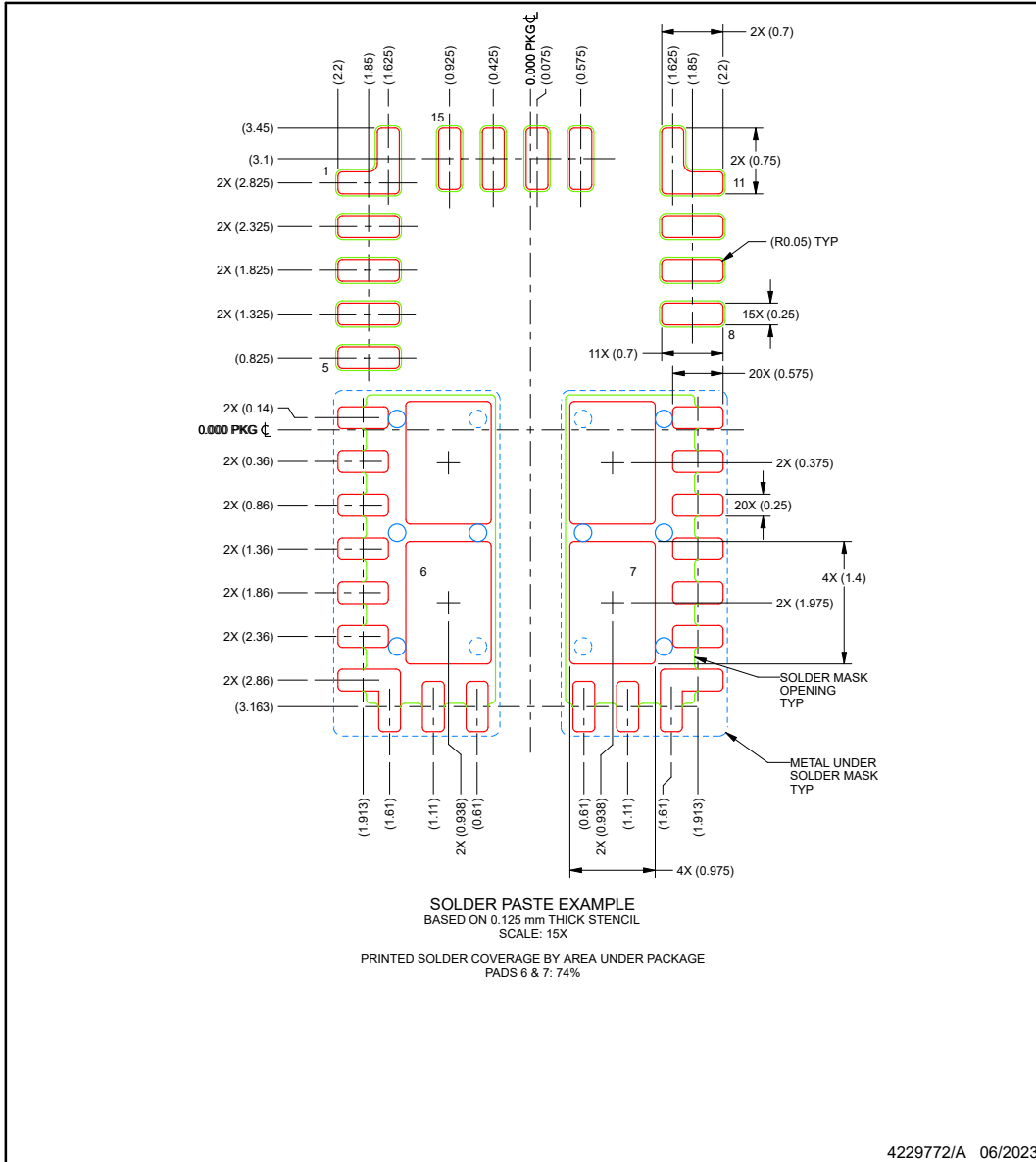

NOTES: (continued)

6. Laser cutting apertures with trapezoidal walls and rounded corners may offer better paste release. IPC-7525 may have alternate design recommendations.

11.2 Tape and Reel Information

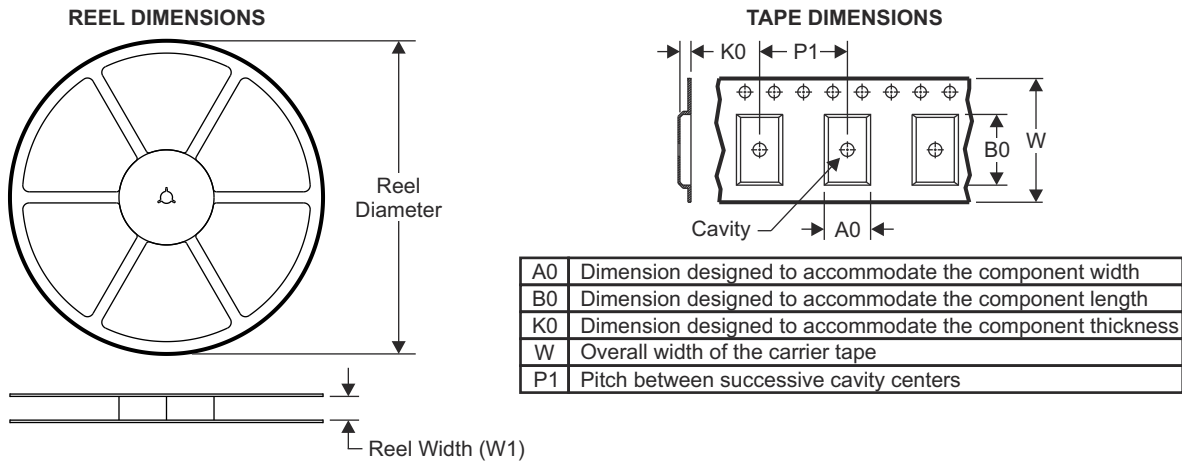

QUADRANT ASSIGNMENTS FOR PIN 1 ORIENTATION IN TAPE

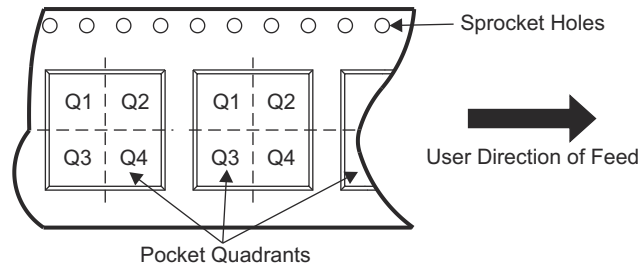

Device	Package Type	Package Drawing	Pins	SPQ	Reel Diameter (mm)	Reel Width W1 (mm)	A0 (mm)	B0 (mm)	K0 (mm)	P1 (mm)	W (mm)	Pin1 Quadrant
LMG3100MOFT	QFM	MOF	9	250	180	16.4	6.3	8.3	2.2	12.0	16.0	Q1
LMG3100MOFR	QFM	MOF	9	2000	330	16.4	6.3	8.3	2.2	12.0	16.0	Q1

ADVANCE INFORMATION

TAPE AND REEL BOX DIMENSIONS

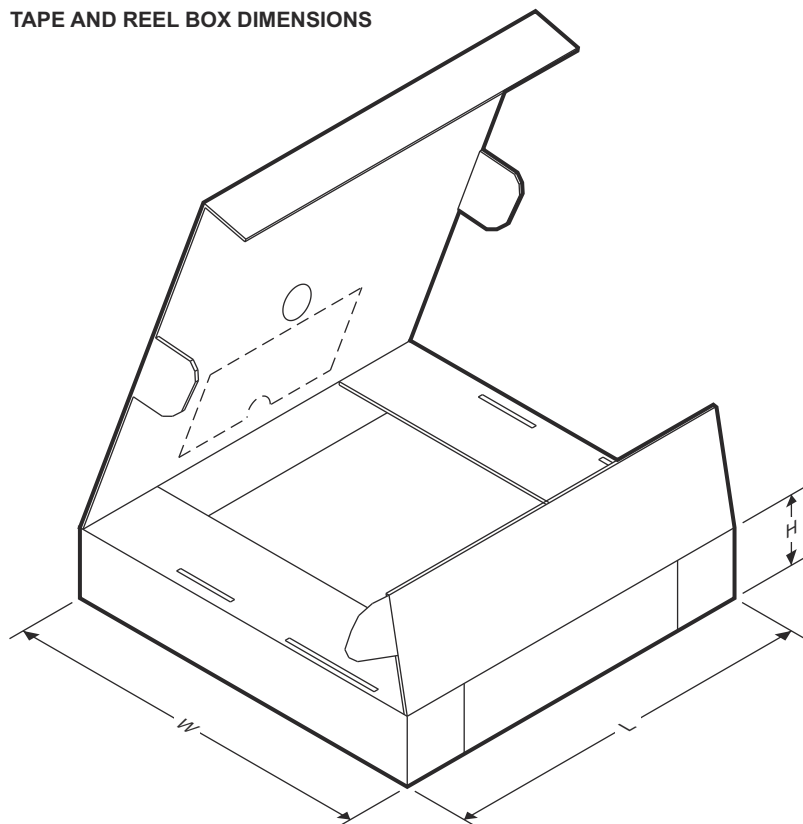

ADVANCE INFORMATION

Device	Package Type	Package Drawing	Pins	SPQ	Length (mm)	Width (mm)	Height (mm)
LMG31000MOFT	QFM	MOF	9	250	213	191	55
LMG31000MOFR	QFM	MOF	9	2000	336.6	336.6	28.6

PACKAGING INFORMATION

Orderable Device	Status (1)	Package Type	Package Drawing	Pins	Package Qty	Eco Plan (2)	Lead finish/ Ball material (6)	MSL Peak Temp (3)	Op Temp (°C)	Device Marking (4/5)	Samples
XLMG3100R017VBER	ACTIVE	VQFN-FCRLF	VBE	15	2500	TBD	Call TI	Call TI	-40 to 125		Samples

(1) The marketing status values are defined as follows:

ACTIVE: Product device recommended for new designs.

LIFEBUY: TI has announced that the device will be discontinued, and a lifetime-buy period is in effect.

NRND: Not recommended for new designs. Device is in production to support existing customers, but TI does not recommend using this part in a new design.

PREVIEW: Device has been announced but is not in production. Samples may or may not be available.

OBSELETE: TI has discontinued the production of the device.

(2) **RoHS:** TI defines "RoHS" to mean semiconductor products that are compliant with the current EU RoHS requirements for all 10 RoHS substances, including the requirement that RoHS substance do not exceed 0.1% by weight in homogeneous materials. Where designed to be soldered at high temperatures, "RoHS" products are suitable for use in specified lead-free processes. TI may reference these types of products as "Pb-Free".

RoHS Exempt: TI defines "RoHS Exempt" to mean products that contain lead but are compliant with EU RoHS pursuant to a specific EU RoHS exemption.

Green: TI defines "Green" to mean the content of Chlorine (Cl) and Bromine (Br) based flame retardants meet JS709B low halogen requirements of <=1000ppm threshold. Antimony trioxide based flame retardants must also meet the <=1000ppm threshold requirement.

(3) MSL, Peak Temp. - The Moisture Sensitivity Level rating according to the JEDEC industry standard classifications, and peak solder temperature.

(4) There may be additional marking, which relates to the logo, the lot trace code information, or the environmental category on the device.

(5) Multiple Device Markings will be inside parentheses. Only one Device Marking contained in parentheses and separated by a "-" will appear on a device. If a line is indented then it is a continuation of the previous line and the two combined represent the entire Device Marking for that device.

(6) Lead finish/Ball material - Orderable Devices may have multiple material finish options. Finish options are separated by a vertical ruled line. Lead finish/Ball material values may wrap to two lines if the finish value exceeds the maximum column width.

Important Information and Disclaimer:The information provided on this page represents TI's knowledge and belief as of the date that it is provided. TI bases its knowledge and belief on information provided by third parties, and makes no representation or warranty as to the accuracy of such information. Efforts are underway to better integrate information from third parties. TI has taken and continues to take reasonable steps to provide representative and accurate information but may not have conducted destructive testing or chemical analysis on incoming materials and chemicals. TI and TI suppliers consider certain information to be proprietary, and thus CAS numbers and other limited information may not be available for release.

In no event shall TI's liability arising out of such information exceed the total purchase price of the TI part(s) at issue in this document sold by TI to Customer on an annual basis.

IMPORTANT NOTICE AND DISCLAIMER

TI PROVIDES TECHNICAL AND RELIABILITY DATA (INCLUDING DATA SHEETS), DESIGN RESOURCES (INCLUDING REFERENCE DESIGNS), APPLICATION OR OTHER DESIGN ADVICE, WEB TOOLS, SAFETY INFORMATION, AND OTHER RESOURCES "AS IS" AND WITH ALL FAULTS, AND DISCLAIMS ALL WARRANTIES, EXPRESS AND IMPLIED, INCLUDING WITHOUT LIMITATION ANY IMPLIED WARRANTIES OF MERCHANTABILITY, FITNESS FOR A PARTICULAR PURPOSE OR NON-INFRINGEMENT OF THIRD PARTY INTELLECTUAL PROPERTY RIGHTS.

These resources are intended for skilled developers designing with TI products. You are solely responsible for (1) selecting the appropriate TI products for your application, (2) designing, validating and testing your application, and (3) ensuring your application meets applicable standards, and any other safety, security, regulatory or other requirements.

These resources are subject to change without notice. TI grants you permission to use these resources only for development of an application that uses the TI products described in the resource. Other reproduction and display of these resources is prohibited. No license is granted to any other TI intellectual property right or to any third party intellectual property right. TI disclaims responsibility for, and you will fully indemnify TI and its representatives against, any claims, damages, costs, losses, and liabilities arising out of your use of these resources.

TI's products are provided subject to [TI's Terms of Sale](#) or other applicable terms available either on [ti.com](https://www.ti.com) or provided in conjunction with such TI products. TI's provision of these resources does not expand or otherwise alter TI's applicable warranties or warranty disclaimers for TI products.

TI objects to and rejects any additional or different terms you may have proposed.

Mailing Address: Texas Instruments, Post Office Box 655303, Dallas, Texas 75265
Copyright © 2024, Texas Instruments Incorporated