

TPS3762-Q1 Automotive 65V Window (OV & UV) Supervisor with Built-In Self-Test and Latch

1 Features

- ASIL-D Functional Safety-Compliant
 - Documentation to aid ISO 26262 system design
 - Systematic capability up to ASIL-D
 - Hardware capability up to ASIL-D
- AEC-Q100 qualified for automotive applications
 - Device temperature grade 1: -40°C to $+125^{\circ}\text{C}$
- Device flexibility to meet design requirements
 - Wide voltage threshold range: 2.7V to 60V
 - 800mV option - use with external resistor divider to set threshold
 - Built-in hysteresis (2%, 5%, and 10% options)
 - Fixed and programmable reset time delay
 - Fixed and programmable detection delay
- Monitor high voltage power rails
 - Wide input voltage range: 2.7V to 65V
 - Reverse polarity protection on sense pin -65V
- Fast UV/OV protection in 12/24/48V systems
 - Output reset latching feature
 - Ultra-fast detection time delay option(5 μs)
 - Built-In Self-Test

2 Applications

- [Sensor fusion and cameras](#)
- [Digital cockpit processing unit](#)
- [On-board charger](#)
- [ADAS domain controller](#)

3 Description

The TPS3762-Q1 is a 65V input voltage supervisor with 4 μA I_{DD} , 0.9% accuracy, fast detection time (5 μs), and a Built-In Self-Test feature. This device can be connected directly to 12V / 24V automotive battery systems for continuous monitoring of overvoltage (OV) and undervoltage (UV) conditions; with the internal resistor divider, the TPS3762-Q1 offers the smallest total solution size. Wide hysteresis voltage options are available to ignore large voltage transients and prevent false reset signals.

The separate VDD and SENSE pins allow redundancy sought by high-reliability systems and SENSE can monitor higher and lower voltages than VDD. Optional use of external resistors are supported by the high impedance input of the SENSE pin. CTS and CTR pins allow delay adjustability on the falling and rising edges of the RESET signal. The CTS functions as a debouncer by ignoring voltage glitches on the monitored voltage rails.

The TPS3762-Q1 is available in a 2.9mm \times 1.6mm SOT23 8-pin package.

Device Information

PART NUMBER	PACKAGE ⁽¹⁾	BODY SIZE (NOM) ⁽²⁾
TPS3762-Q1	SOT-23 (8) (DDF)	2.9mm x 1.6mm

- (1) For package details, see the mechanical drawing addendum at the end of the data sheet.
- (2) The package size (length \times width) is a nominal value and includes pins, where applicable.

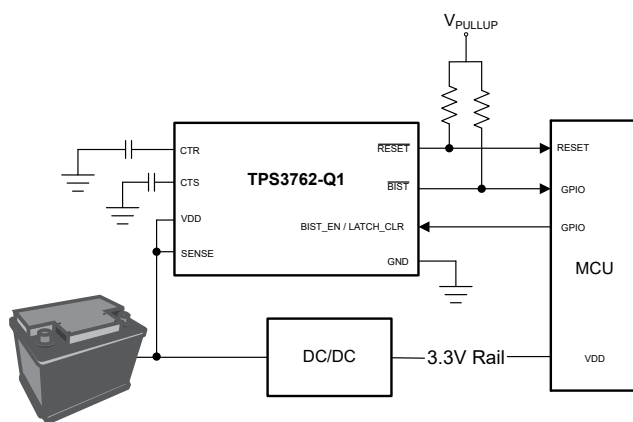

Typical Applications Circuit

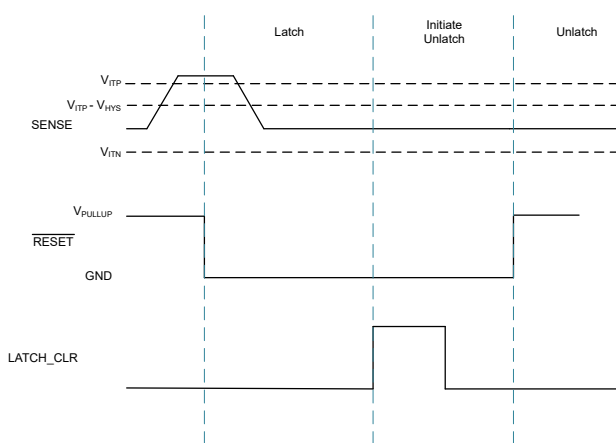

Latch Functionality Waveform



Table of Contents

1 Features	1	10.2 Functional Block Diagram.....	16
2 Applications	1	10.3 Feature Description.....	17
3 Description	1	10.4 Device Functional Modes.....	30
4 Device Nomenclature	3	11 Application and Implementation	31
5 Device Comparison	4	11.1 Application Information.....	31
6 Pin Configuration and Functions	5	11.2 Adjustable Voltage Thresholds.....	31
7 Specifications	6	11.3 Typical Application.....	32
7.1 Absolute Maximum Ratings.....	6	11.4 Power Supply Recommendations.....	36
7.2 ESD Ratings	6	11.5 Layout.....	36
7.3 Recommended Operating Conditions.....	6	12 Device and Documentation Support	38
7.4 Thermal Information	7	12.1 Receiving Notification of Documentation Updates..	38
7.5 Electrical Characteristics.....	8	12.2 Support Resources.....	38
7.6 Switching Requirements.....	10	12.3 Trademarks.....	38
7.7 Timing Requirements.....	11	12.4 Electrostatic Discharge Caution.....	38
8 Timing Diagrams	12	12.5 Glossary.....	38
9 Typical Characteristics	14	13 Revision History	38
10 Detailed Description	16	14 Mechanical, Packaging, and Orderable Information	38
10.1 Overview.....	16		

4 Device Nomenclature

[Device Decoder](#) in [Section 5](#) describe how to decode certain device function of the device based on its part number. Not all part numbers follow this nomenclature. Use [Table 4-1](#) as the part number decoding table for all devices.

Table 4-1. Device Configuration Table

ORDERABLE PART NAME	Overvoltage (V_{ITP})	Overvoltage Hysteresis	Undervoltage (V_{ITN})	Undervoltage Hysteresis	CTR / CTS	Latch / UVbypass	BIST RESET Trigger
TPS3762D02OVDDFRQ1	800mV	2%	N/A	N/A	ADJ / ADJ	Both	Yes

5 Device Comparison

Device Decoder shows some of the device naming nomenclature of the TPS3762-Q1. Not all device namings follow this nomenclature table. For a detailed breakdown of every device part number by threshold voltage options, BIST configurations, Latch configurations, CTR options, CTS options, and UV bypass, see Section 4 for more details. Contact TI sales representatives or on TI's E2E forum for detail and availability of other options.

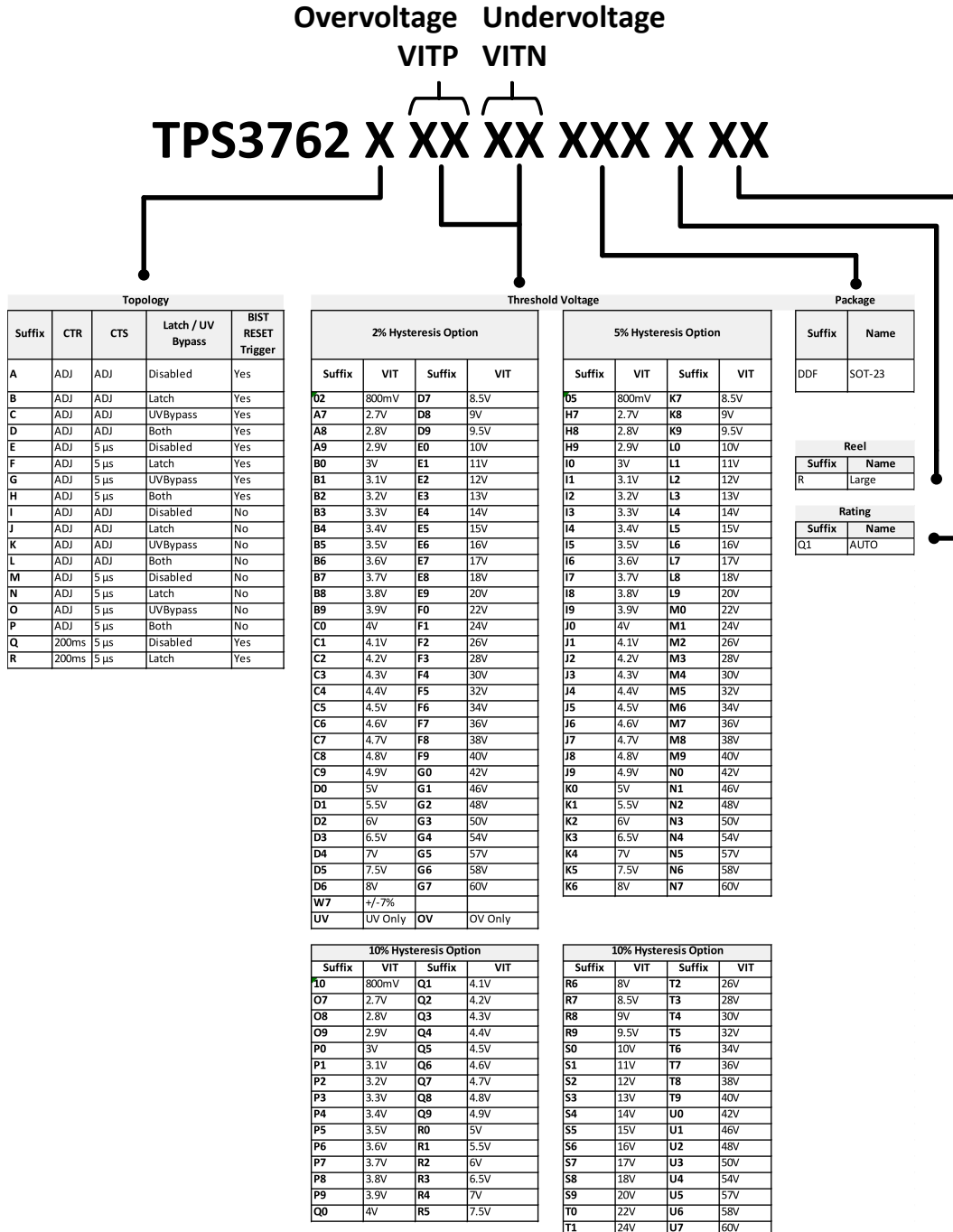

1. Suffix 02, 05, and 10 with VIT of 800mV corresponds to the adjustable variant, do not have internal voltage divider
2. Not all TPS3762-Q1 devices can be decoded by this table. Refer to Section 4 for a decoding table by part number.

6 Pin Configuration and Functions

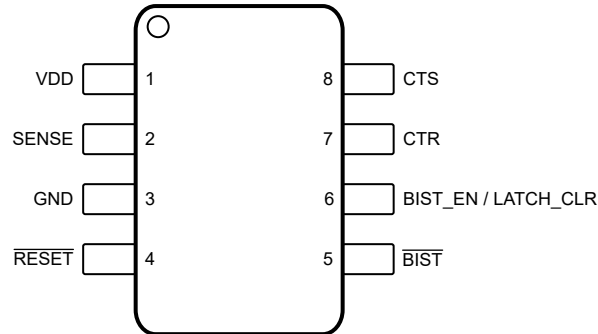

**Figure 6-1. DDF Package,
8-Pin SOT-23,
TPS3762-Q1 (Top View)**

Table 6-1. Pin Functions

PIN		I/O	DESCRIPTION
NAME	NO.		
VDD	1	I	Input Supply Voltage: Supply voltage pin. For noisy systems, bypass with a 0.1µF capacitor to GND.
SENSE	2	I	Sense Voltage: Connect this pin to the supply rail that must be monitored. See Section 8.3.2 for more details. Sensing Topology: Overvoltage (OV) or Undervoltage (UV) or Window (OV + UV)
GND	3	-	Ground. Ground pin. All GND pins must be electrically connected to the board ground.
$\overline{\text{RESET}}$	4	O	Output Reset Signal: $\overline{\text{RESET}}$ asserts when SENSE crosses the voltage threshold after the sense time delay, set by CTS, and remains asserted for the reset time delay period, set by CTR, after SENSE transitions out of a fault condition. For latch variants $\overline{\text{RESET}}$ remains asserted until the latch is cleared. The active low open-drain reset output requires an external pullup resistor. See Section 8.3.3.2 for more details. Output topology: Open-Drain Active-Low
$\overline{\text{BIST}}$	5	O	Built-In Self-Test: $\overline{\text{BIST}}$ asserts when a logic high input occurs on the BIST_EN / LATCH_CLR or BIST_EN pin, this initiates the internal BIST testing. $\overline{\text{BIST}}$ recovers after $t_{\overline{\text{BIST}}}$ to signify BIST completed successfully. $\overline{\text{BIST}}$ remains asserted for a time period longer than $t_{\overline{\text{BIST}}}$ if there is a failure during BIST. $\overline{\text{BIST}}$ active-low open-drain output requires an external pullup resistor. See Section 8.3.6 for more details.
BIST_EN / LATCH_CLR	6	I	Built-in Self-test Enable and Latch Clear: A logic high input must occur on the BIST_EN / LATCH_CLR to initiate BIST and clear a latched OV/UV fault. See Section 8.3.6 for more details.
CTR	7	O	RESET Time Delay: User-programmable reset time delay for $\overline{\text{RESET}}$. Connect an external capacitor for adjustable time delay or leave the pin floating for the shortest delay. See Section 8.3.4 for more details.
CTS	8	O	SENSE Time Delay: User-programmable sense time delay for SENSE. Connect an external capacitor for adjustable time delay or leave the pin floating for the shortest delay. See Section 8.3.5 for more details.

7 Specifications

7.1 Absolute Maximum Ratings

over operating free-air temperature range, unless otherwise noted ⁽¹⁾

		MIN	MAX	UNIT
Voltage	V_{DD} , $V_{SENSE(Adjustable)}$, V_{RESET}	-0.3	70	V
Voltage	$V_{SENSE(Fixed)}$	-65	70	V
Voltage	V_{CTS} , V_{CTR}	-0.3	6	V
Voltage	V_{BIST} , V_{BIST_EN} , $V_{BIST_EN/LATCH_CLR}$	-0.3	6	V
Current	I_{RESET} , I_{BIST}		10	mA
Temperature ⁽²⁾	Operating junction temperature, T_J	-40	150	°C
Temperature ⁽²⁾	Operating Ambient temperature, T_A	-40	150	°C
Temperature ⁽²⁾	Storage, T_{stg}	-65	150	°C

- (1) Stresses beyond those listed under Absolute Maximum Ratings may cause permanent damage to the device. These are stress ratings only, which do not imply functional operation of the device at these or any other conditions beyond those indicated under Recommended Operating Conditions. Exposure to absolute-maximum-rated conditions for extended periods may affect device reliability.
- (2) As a result of the low dissipated power in this device, it is assumed that $T_J = T_A$.

7.2 ESD Ratings

			VALUE	UNIT
$V_{(ESD)}$	Electrostatic discharge	Human body model (HBM), per AEC Q100-002 ⁽¹⁾	±2000	V
		Charged device model (CDM), per AEC Q100-011	±750	

- (1) AEC Q100-002 indicates that HBM stressing shall be in accordance with the ANSI/ESDA/JEDEC JS-001 specification.

7.3 Recommended Operating Conditions

over operating free-air temperature range (unless otherwise noted)

		MIN	NOM	MAX	UNIT
Voltage	V_{DD}	2.7		65	V
Voltage	V_{SENSE} , V_{RESET}	0		65	V
Voltage	V_{CTS} , V_{CTR}	0		5.5	V
Voltage	V_{BIST} , V_{BIST_EN} , $V_{BIST_EN/LATCH_CLR}$	0		5.5	V
Current	I_{RESET} , I_{BIST}	0		5	mA
T_J ⁽¹⁾	Junction temperature (free air temperature)	-40		125	°C

- (1) As a result of the low dissipated power in this device, it is assumed that $T_J = T_A$.

7.4 Thermal Information

THERMAL METRIC ⁽¹⁾		TPS3762-Q1		
		DDF		
		8-PIN		
				UNIT
$R_{\theta JA}$	Junction-to-ambient thermal resistance	154.6		°C/W
$R_{\theta JC(top)}$	Junction-to-case (top) thermal resistance	77.4		°C/W
$R_{\theta JB}$	Junction-to-board thermal resistance	73.2		°C/W
Ψ_{JT}	Junction-to-top characterization parameter	4.8		°C/W
Ψ_{JB}	Junction-to-board characterization parameter	72.9		°C/W
$R_{\theta JC(bot)}$	Junction-to-case (bottom) thermal resistance	N/A		°C/W

(1) For more information about traditional and new thermal metrics, see the [Semiconductor and IC Package Thermal Metrics](#) application report.

7.5 Electrical Characteristics

At $V_{DD(MIN)} \leq V_{DD} \leq V_{DD(MAX)}$, CTR = CTS = open, output $\overline{\text{RESET}}$ pull-up resistor $R_{PU} = 10k\Omega$, voltage $V_{PU} = 5.5V$, output $\overline{\text{BIST}}$ pull-up resistor $R_{PU_BIST} = 10k\Omega$, voltage $V_{PU_BIST} = 5.5V$, and load $C_{LOAD} = 10pF$. The operating free-air temperature range $T_A = -40^\circ\text{C}$ to 125°C , unless otherwise noted. Typical values are at $T_A = 25^\circ\text{C}$ and $V_{DD} = 12V$ and $V_{IT} = 6.5V$ (V_{IT} refers to V_{ITN} or V_{ITP}).

PARAMETER	TEST CONDITIONS	MIN	TYP	MAX	UNIT	
POWER SUPPLY						
V_{DD}	Supply Voltage	2.7		65	V	
UVLO ⁽¹⁾	Undervoltage Lockout	V_{DD} rising above $V_{DD(MIN)}$		2.6	V	
UVLO(HYS) ⁽¹⁾	Undervoltage Lockout Hysteresis	V_{DD} falling below $V_{DD(MIN)}$	500		mV	
$V_{POR(RESET)}$	Power on Reset Voltage ⁽²⁾ RESET, Active Low (Open-Drain)	$V_{OL(MAX)} = 300mV$ $I_{OUT(SINK)} = 15\mu A$		1.4	V	
$V_{POR(BIST)}$	Power on Reset Voltage ⁽²⁾ BIST, Active Low (Open-Drain)	$V_{OL(MAX)} = 300mV$ $I_{OUT(SINK)} = 15\mu A$		1.4	V	
I_{DD}	Supply current into V_{DD} pin	$V_{IT} = 800mV$ $V_{DD(MIN)} \leq V_{DD} \leq V_{DD(MAX)}$	4	8.1	μA	
SENSE (Input)						
I_{SENSE}	Input current	$V_{IT} = 800mV$		200	nA	
V_{ITN}	Input Threshold Negative (Undervoltage)	$V_{IT} = 800mV$ ⁽³⁾	-0.9	0.9	%	
V_{ITP}	Input Threshold Positive (Overvoltage)	$V_{IT} = 800mV$ ⁽³⁾	-0.9	0.9	%	
V_{HYS}	Hysteresis Accuracy ⁽⁴⁾	$V_{IT} = 0.8V$ V_{HYS} Range = 2%	1.5	2	2.5	%
RESET (Output)						
$I_{kg(OD)}$	Open-Drain leakage	$V_{RESET} = 5.5V$ $V_{ITN} < V_{SENSE} < V_{ITP}$		300	nA	
$I_{kg(OD)}$	Open-Drain leakage	$V_{RESET} = 65V$ $V_{ITN} < V_{SENSE} < V_{ITP}$		300	nA	
V_{OL} ⁽⁵⁾	Low level output voltage	$2.7V \leq V_{DD} \leq 65V$ $I_{RESET} = 2.7mA$		350	mV	

7.5 Electrical Characteristics (continued)

At $V_{DD(MIN)} \leq V_{DD} \leq V_{DD(MAX)}$, CTR = CTS = open, output $\overline{\text{RESET}}$ pull-up resistor $R_{PU} = 10k\Omega$, voltage $V_{PU} = 5.5V$, output BIST pull-up resistor $R_{PU_BIST} = 10k\Omega$, voltage $V_{PU_BIST} = 5.5V$, and load $C_{LOAD} = 10pF$. The operating free-air temperature range $T_A = -40^\circ\text{C}$ to 125°C , unless otherwise noted. Typical values are at $T_A = 25^\circ\text{C}$ and $V_{DD} = 12V$ and $V_{IT} = 6.5V$ (V_{IT} refers to V_{ITN} or V_{ITP}).

PARAMETER		TEST CONDITIONS	MIN	TYP	MAX	UNIT
Capacitor Timing (CTS, CTR)						
R_{CTR}	Internal resistance (CTR)		2.96	3.7	4.44	M Ω
R_{CTS}	Internal resistance (CTS)		2.96	3.7	4.44	M Ω
Built-in Self-test						
$I_{kg(BIST)}$	Open-Drain leakage	$V_{BIST} = 5.5V$ $V_{ITN} < V_{SENSE} < V_{ITP}$			300	nA
$I_{kg(BIST)}$	Open-Drain leakage	$V_{BIST} = 3.3V$ $V_{ITN} < V_{SENSE} < V_{ITP}$			300	nA
V_{BIST_OL}	Low level output voltage	$2.7V \leq V_{DD} \leq 65V$ $I_{BIST} = 5mA$			300	mV
V_{BIST_EN}	BIST_EN pin logic low input				500	mV
V_{BIST_EN}	BIST_EN pin logic high input		1300			mV
$V_{BIST_EN}/$ LATCH_CLR	LATCH_CLR pin logic low input				500	mV
$V_{BIST_EN}/$ LATCH_CLR	LATCH_CLR pin logic high input		1300			mV

- (1) When V_{DD} voltage falls below UVLO, $\overline{\text{RESET}}$ is asserted. V_{DD} slew rate $\leq 100mV / \mu s$
- (2) V_{POR} is the minimum V_{DD} voltage for a controlled output state. Below V_{POR} , the output cannot be determined. V_{DD} slew rate $\leq 100mV/\mu s$
- (3) For adjustable voltage guidelines and resistor selection refer to **Adjustable Voltage Thresholds** in **Application and Implementation section**
- (4) Hysteresis is with respect to V_{ITP} and V_{ITN} voltage threshold. V_{ITP} has negative hysteresis and V_{ITN} has positive hysteresis.
- (5) For V_{OH} and V_{OL} relation to output variants refer to **Timing Figures after the Timing Requirement Table**

7.6 Switching Requirements

At $V_{DD(MIN)} \leq V_{DD} \leq V_{DD(MAX)}$, CTR = CTS = open and enabled, output $\overline{\text{RESET}}$ pull-up resistor $R_{PU} = 10\text{k}\Omega$, voltage $V_{PU} = 5.5\text{V}$, output $\overline{\text{BIST}}$ pull-up resistor $R_{PU_BIST} = 10\text{k}\Omega$, voltage $V_{PU_BIST} = 5.5\text{V}$, and load $C_{LOAD} = 10\text{pF}$. The operating free-air temperature range $T_A = -40^\circ\text{C}$ to 125°C , unless otherwise noted. Typical values are at $T_A = 25^\circ\text{C}$ and $V_{DD} = 12\text{V}$ and $V_{IT} = 6.5\text{V}$ (V_{IT} refers to V_{ITN} or V_{ITP}).

PARAMETER		TEST CONDITIONS	MIN	TYP	MAX	UNIT
Common Switching Requirements						
$t_{CTR(\text{No Cap})}$	$\overline{\text{RESET}}$ release time delay (CTR) ⁽¹⁾	$V_{IT} = 800\text{mV}$ $C_{CTR} = \text{Open}$ 20% Overdrive from Hysteresis		350	600	μs
$t_{CTS(\text{No Cap})}$	Sense detect time delay (CTS) ⁽²⁾	$V_{IT} = 800\text{mV}$ $C_{CTS} = \text{Open}$ 20% Overdrive from V_{IT}		85	100	μs
t_{SD}	Startup Delay ⁽³⁾	$C_{CTR} = \text{Open}$		1		ms
BIST Switching Requirements						
$t_{BIST_en_pd}$	Rising edge of BIST_EN to $\overline{\text{BIST}}$ asserting			2.3		μs
$t_{BIST_en_pd}$	Rising edge of BIST_EN to $\overline{\text{RESET}}$ asserting			2.3		μs
$t_{\overline{\text{BIST}}_recover}$	Rising edge of $\overline{\text{BIST}}$ to SENSE input valid	$C_{CTR} = \text{Open}$, BIST = Enabled		350	600	μs
$t_{\overline{\text{BIST}}}$	BIST run time				3.5	ms
$t_{SD+\overline{\text{BIST}}}$	Startup time with BIST run time				4.5	ms
LATCH Switching Requirements						
$t_{\overline{\text{BIST_EN}}/ \text{LATCH_CLR_R} \text{ recover}}$	Rising edge of $\overline{\text{BIST}}$ to SENSE input valid	$C_{CTR} = \text{Open}$, BIST = Disabled		10		μs

- CTR Reset detect time delay:**
Overvoltage active-low output is measure from $V_{ITP-HYS}$ to V_{OH}
Undervoltage active-low output is measure from $V_{ITN+HYS}$ to V_{OH}
- CTS Sense detect time delay:**
Overvoltage active-low output is measure from V_{ITP} to V_{OL}
Undervoltage active-low output is measure from V_{ITN} to V_{OL}
- During the power-on sequence, V_{DD} must be at or above $V_{DD(MIN)}$ for at least $t_{SD+\overline{\text{BIST}}} + t_{CTR}$ before the output is in the correct state based on V_{SENSE} .
 t_{SD} time includes the propagation delay ($C_{CTR} = \text{Open}$). Capacitor on CTR will add time to t_{SD} .

7.7 Timing Requirements

At $V_{DD(MIN)} \leq V_{DD} \leq V_{DD(MAX)}$, CTR = CTS = open and enabled, output $\overline{\text{RESET}}$ pull-up resistor $R_{PU} = 10k\Omega$, voltage $V_{PU} = 5.5V$, output $\overline{\text{BIST}}$ pull-up resistor $R_{PU_BIST} = 10k\Omega$, voltage $V_{PU_BIST} = 5.5V$, and load $C_{LOAD} = 10pF$. The operating free-air temperature range $T_A = -40^\circ\text{C}$ to 125°C , unless otherwise noted. Typical values are at $T_A = 25^\circ\text{C}$ and $V_{DD} = 12V$ and $V_{IT} = 6.5V$ (V_{IT} refers to V_{ITN} or V_{ITP}).

PARAMETER	TEST CONDITIONS	MIN	TYP	MAX	UNIT
Common timing parameters					
BIST timing parameters					
$t_{\text{BIST_en Glitch}}$	BIST_EN Glitch immunity		1.1		μs
$t_{\text{BIST_en}}$	Minimum BIST_EN input width to initiate BIST		1.2	8	μs
LATCH timing parameters					
$t_{\text{BIST_EN/LATCH_CLR Glitch}}$	Latch Glitch immunity		1.5		μs
$t_{\text{BIST_EN/LATCH_CLR}}$	Latch input width to clear latch		1.6		μs

8 Timing Diagrams

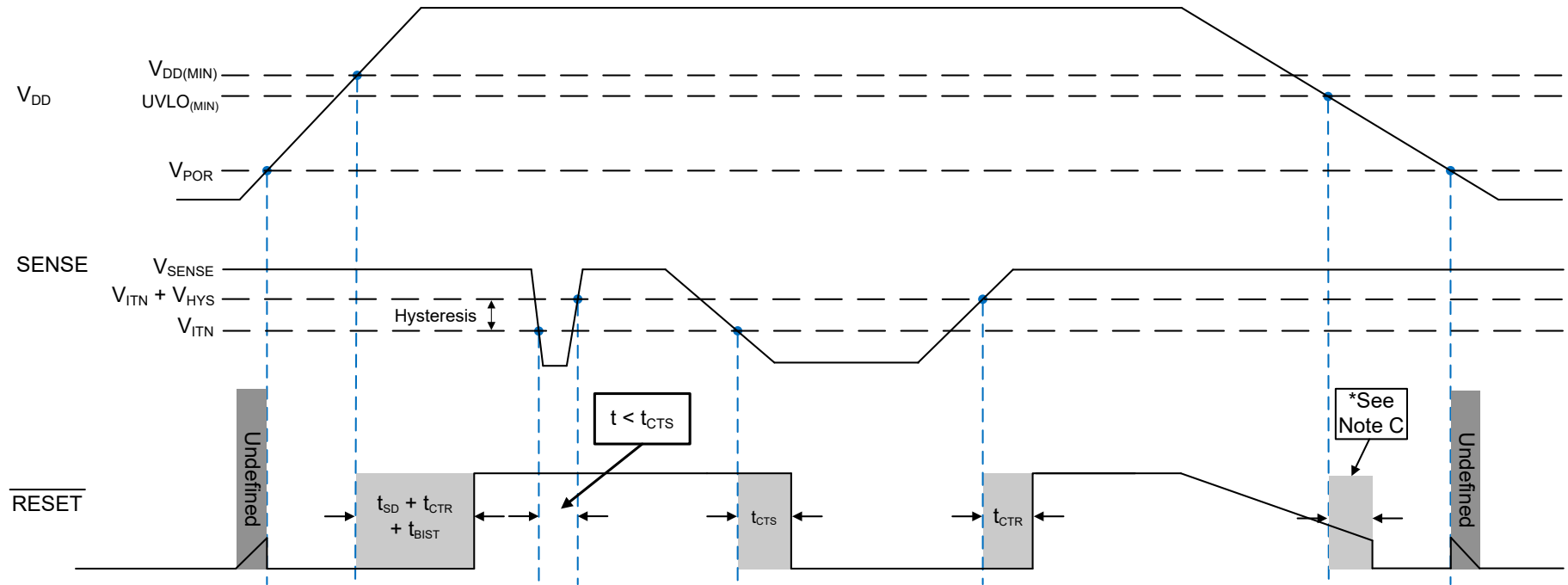

- A. The timing diagram assumes the open-drain output RESET pin is connected via an external pull-up resistor to V_{DD} .
- B. Be advised that [Figure 8-1](#) shows the V_{DD} falling slew rate is slow or the V_{DD} decay time is much larger than the propagation detect delay (t_{CTR}) time.
- C. RESET is asserted when V_{DD} goes below the $UVLO_{(MIN)}$ threshold after the time delay, t_{CTR} , is reached.

Figure 8-1. SENSE Undervoltage (UV) Timing Diagram

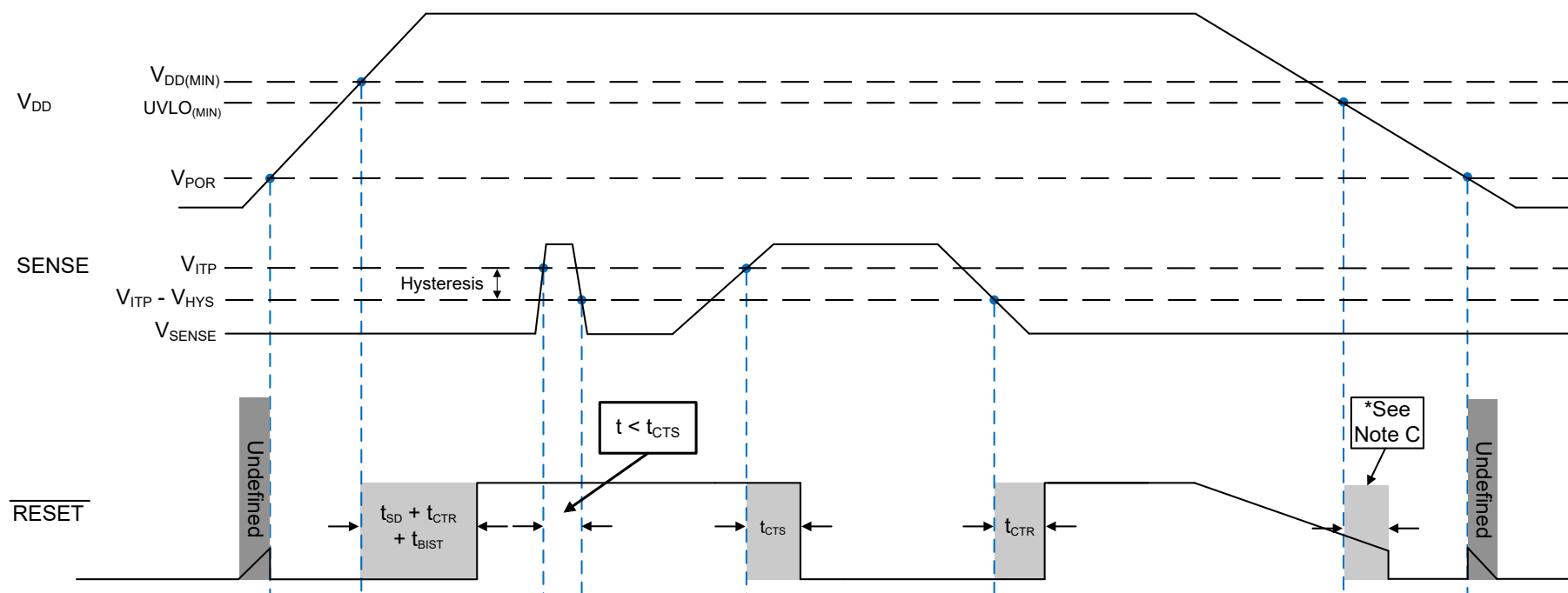

- The timing diagram assumes the open-drain output RESET pin is connected via an external pull-up resistor to V_{DD} .
- Be advised that Figure 8-2 shows the V_{DD} falling slew rate is slow or the V_{DD} decay time is much larger than the propagation detect delay (t_{CTR}) time.
- RESET is asserted when V_{DD} goes below the $UVLO_{(MIN)}$ threshold after the time delay, t_{CTR} , is reached.

Figure 8-2. SENSE Overvoltage (OV) Timing Diagram

9 Typical Characteristics

Typical characteristics show the typical performance of the TPS3762-Q1 device. Test conditions are taken at $T_A = 25^\circ\text{C}$, unless otherwise noted.

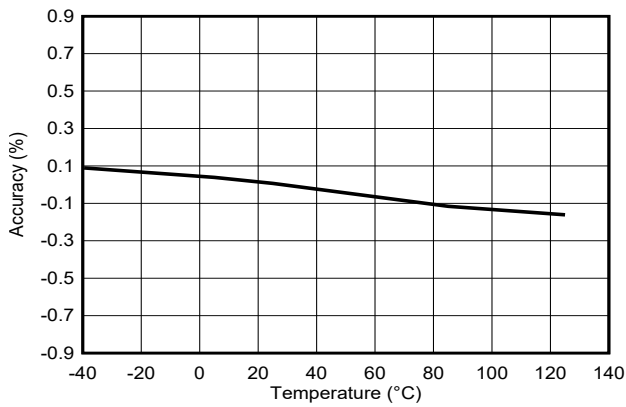

Figure 9-1. Undervoltage Accuracy vs Temperature ($V_{IT} = 0.8\text{V}$)

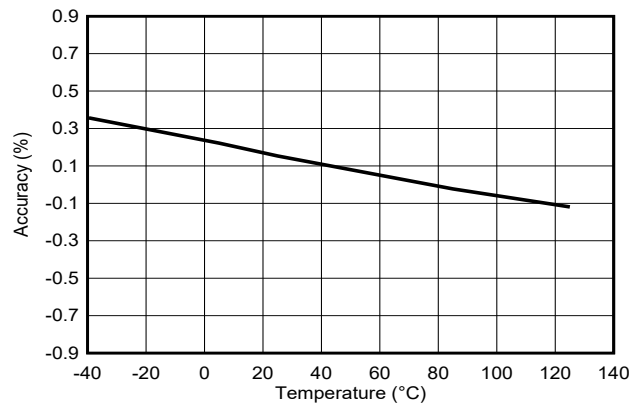

Figure 9-2. Overvoltage Accuracy vs Temperature ($V_{IT} = 0.8\text{V}$)

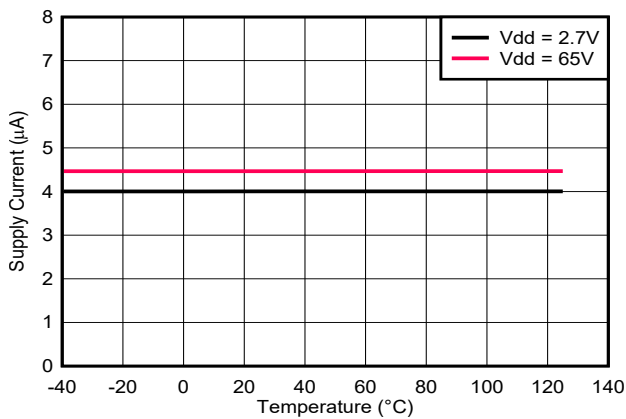

Figure 9-3. I_{DD} vs Temperature (RESET = High, $V_{IT} = 0.8\text{V}$)

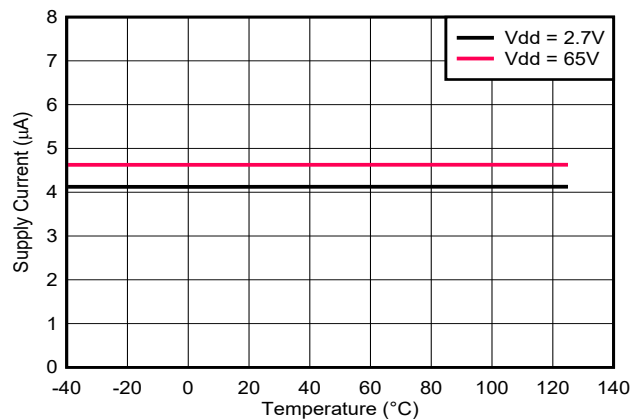

Figure 9-4. I_{DD} vs V_{DD} (RESET = Low, $V_{IT} = 0.8\text{V}$)

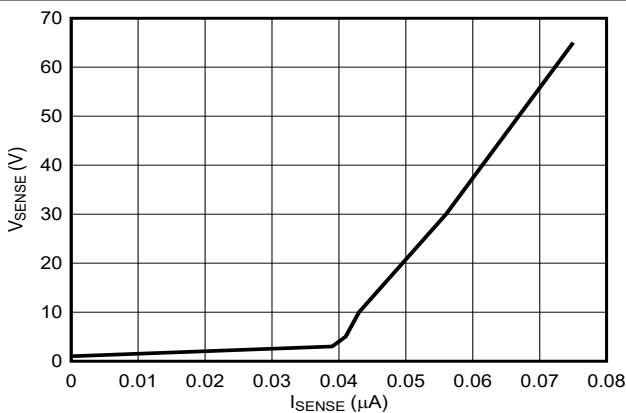

Figure 9-5. V_{SENSE} vs I_{SENSE} ($V_{DD} = 2.7\text{V}$)

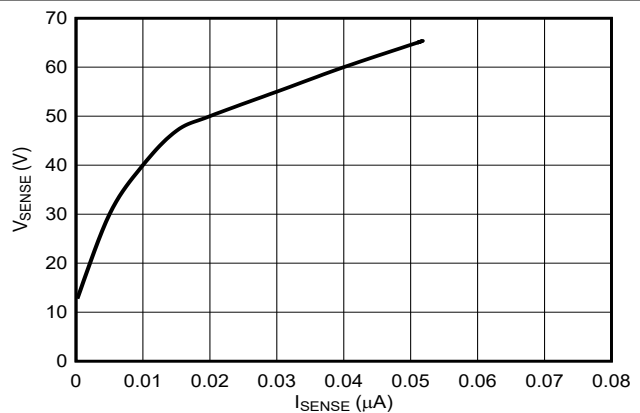

Figure 9-6. V_{SENSE} vs I_{SENSE} ($V_{DD} = 65\text{V}$)

9 Typical Characteristics (continued)

Typical characteristics show the typical performance of the TPS3762-Q1 device. Test conditions are taken at $T_A = 25^\circ\text{C}$, unless otherwise noted.

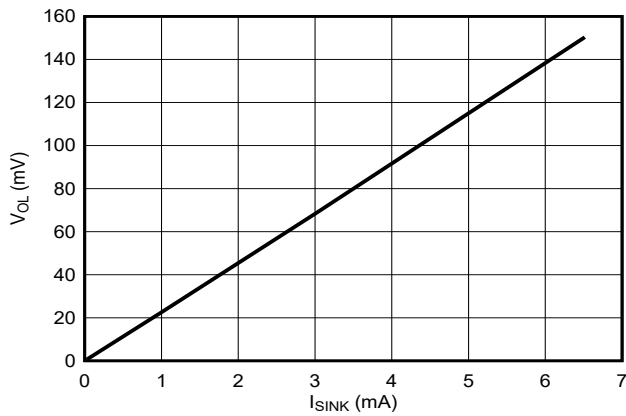

Figure 9-7. Open-Drain Active Low V_{OL} vs I_{RESET} ($V_{\text{DD}} = 2.7\text{V}$)

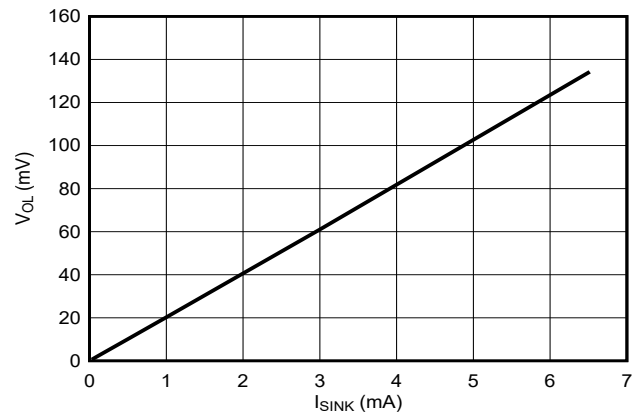

Figure 9-8. Open-Drain Active Low V_{OL} vs I_{RESET} ($V_{\text{DD}} = 65\text{V}$)

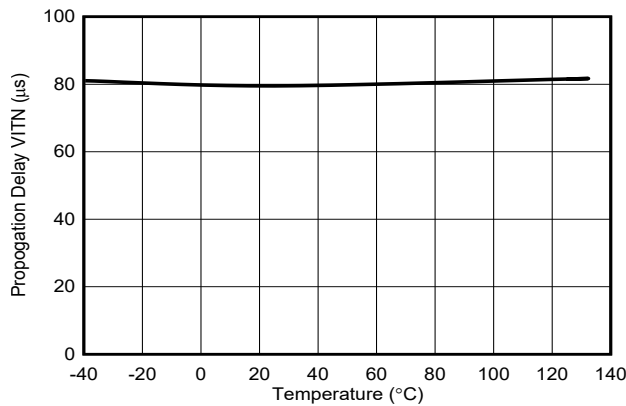

Figure 9-9. Propagation Delay (Undervoltage) vs Temperature ($V_{\text{IT}} = 0.8\text{V}$, CTS = Enabled = 50pF)

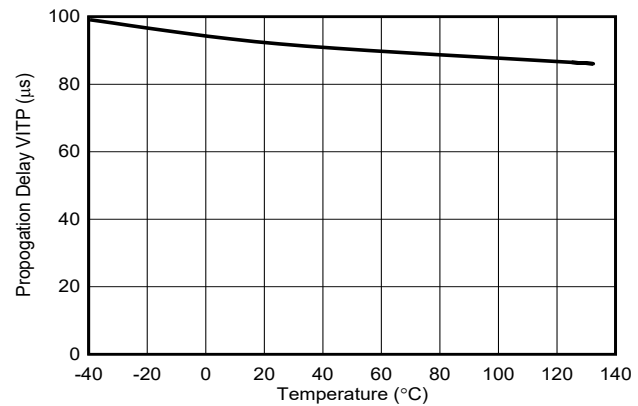

Figure 9-10. Propagation Delay (Overvoltage) vs Temperature ($V_{\text{IT}} = 0.8\text{V}$, CTS = Enabled = 50pF)

10 Detailed Description

10.1 Overview

The TPS3762-Q1 is a family of high voltage and low quiescent current voltage supervisors with overvoltage and undervoltage threshold voltage options, delay timings, Built-In Self-Test, and latch. The TPS3762-Q1 over and undervoltage thresholds are device specific and are offered in either adjustable thresholds or fixed thresholds. The adjustable threshold option uses an external resistor ladder to make a voltage divider on SENSE pin which uses the internal 800mV threshold to trigger overvoltage and undervoltage faults. The benefit of using an adjustable option with external resistors is the faster reaction speed compared to a fixed internal threshold variant. The TPS3762-Q1 fixed threshold option utilizes an integrated voltage divider to eliminate the need for external resistors and provides a lower system leakage current.

VDD, SENSE and $\overline{\text{RESET}}$ pins can support 65V continuous operation. SENSE has -65V reverse polarity protection. VDD, SENSE, and $\overline{\text{RESET}}$ voltage levels can be independent of each other. TPS3762-Q1 includes a reset output latching feature that holds the output active to help system achieve safe state. Fixed and programmable sense and reset delay are available to avoid false resets and false reset releases.

10.2 Functional Block Diagram

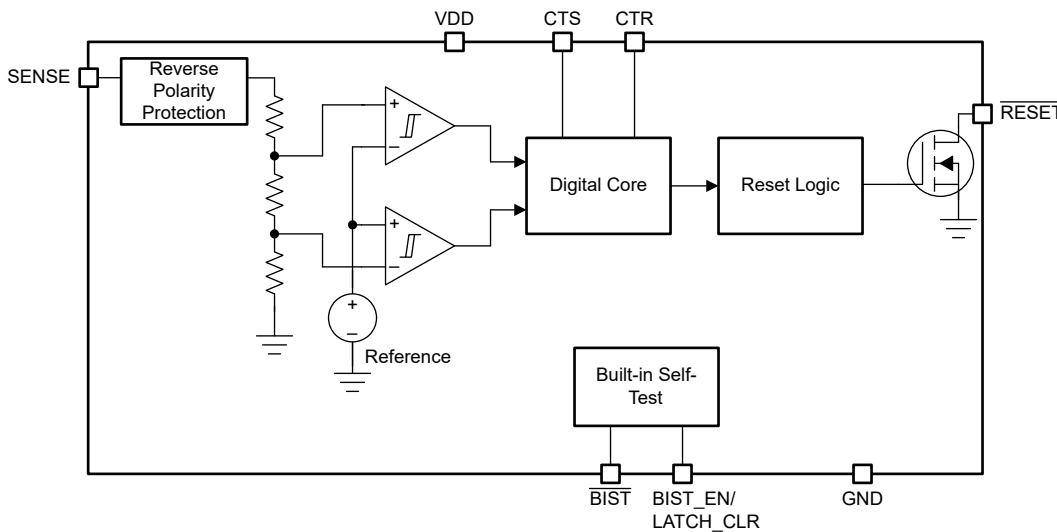

Figure 10-1. Fixed Threshold Functional Block Diagram

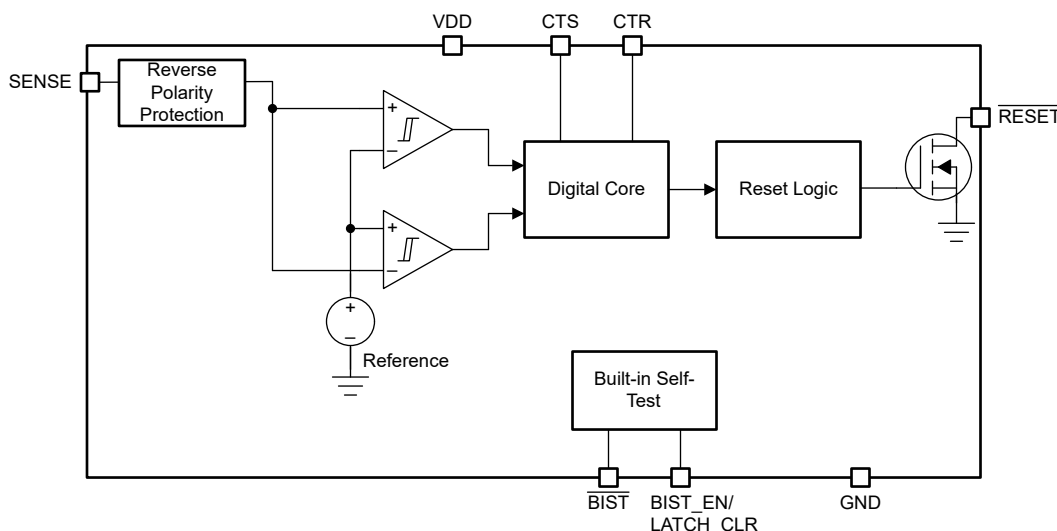

Figure 10-2. Adjustable Threshold Functional Block Diagram

10.3 Feature Description

10.3.1 Input Voltage (VDD)

VDD operating voltage ranges from 2.7V to 65V. An input supply capacitor is not required for this device; however, if the input supply is noisy good analog practice is to place a 0.1µF capacitor between the VDD and GND.

VDD needs to be at or above $V_{DD(MIN)}$ for at least the start-up time delay (t_{SD}) for the device to be fully functional.

VDD voltage is independent of V_{SENSE} and V_{RESET} , meaning that VDD can be higher or lower than the other pins.

10.3.1.1 Undervoltage Lockout ($V_{POR} < V_{DD} < UVLO$)

When the voltage on V_{DD} is less than the UVLO voltage, but greater than the power-on reset voltage (V_{POR}), the \overline{RESET} and $BIST$ pins will be asserted, regardless of the voltage at SENSE pin.

10.3.1.2 Power-On Reset ($V_{DD} < V_{POR}$)

When the voltage on VDD is lower than the power on reset voltage (V_{POR}), the output signal is undefined and is not to be relied upon for proper device function.

Note: Figure 10-3 and Figure 10-4 assume an external pull-up resistor is connecting the \overline{RESET} pin to VDD.

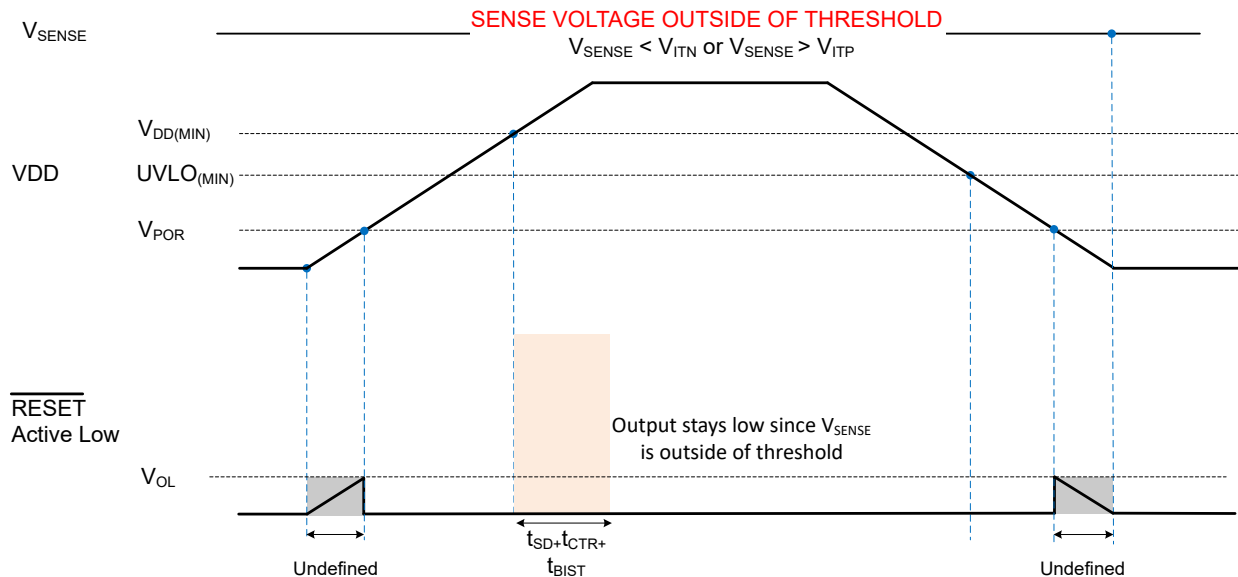

Figure 10-3. Power Cycle (SENSE Outside of Nominal Voltage)

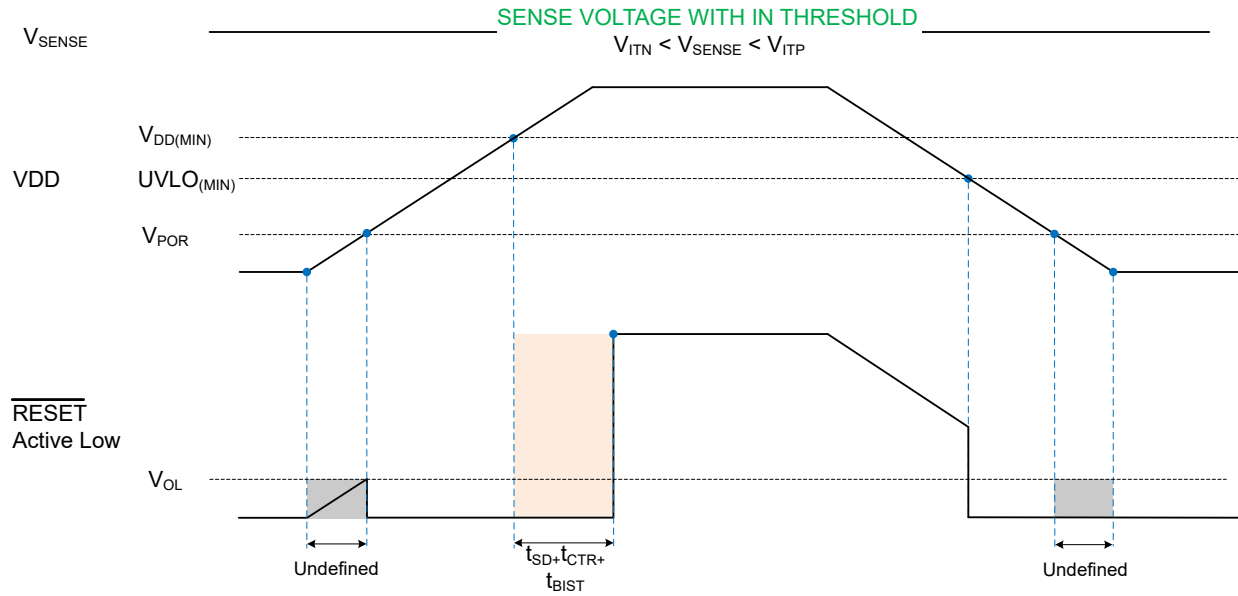

Figure 10-4. Power Cycle (SENSE Within Nominal Voltage)

10.3.2 SENSE

The SENSE pin connects to the supply rail that is to be monitored. The sense pin on each device is configured to monitor either overvoltage (OV), undervoltage (UV), or window (OV&UV) conditions. TPS3762-Q1 device offers built-in hysteresis that provides noise immunity and maintains stable operation.

Although not required in most cases, for noisy applications where t_{CTS} is not sufficient glitch rejection, good analog design practice is to place a 10nF to 100nF bypass capacitor at the SENSE input to reduce sensitivity to transient voltages on the monitored signal. SENSE can be connected directly to VDD pin.

10.3.2.1 Reverse Polarity Protection

The TPS3762-Q1 has reverse polarity protection on the sense pin up to -65V. This allows the TPS3762-Q1 to support accidental or test simulated reverse connections without damaging the device. This protection permits the TPS3762-Q1 to connect directly off of the supply prior to any reverse polarity protection diodes for accurate voltage measurement.

10.3.2.2 SENSE Hysteresis

TPS3762-Q1 device offers built-in hysteresis around the UV and OV thresholds to avoid erroneous $\overline{\text{RESET}}$ deassertions. The hysteresis is opposite to the threshold voltage; for overvoltage options the hysteresis is subtracted from the positive threshold (V_{ITP}), for undervoltage options hysteresis is added to the negative threshold (V_{ITN}).

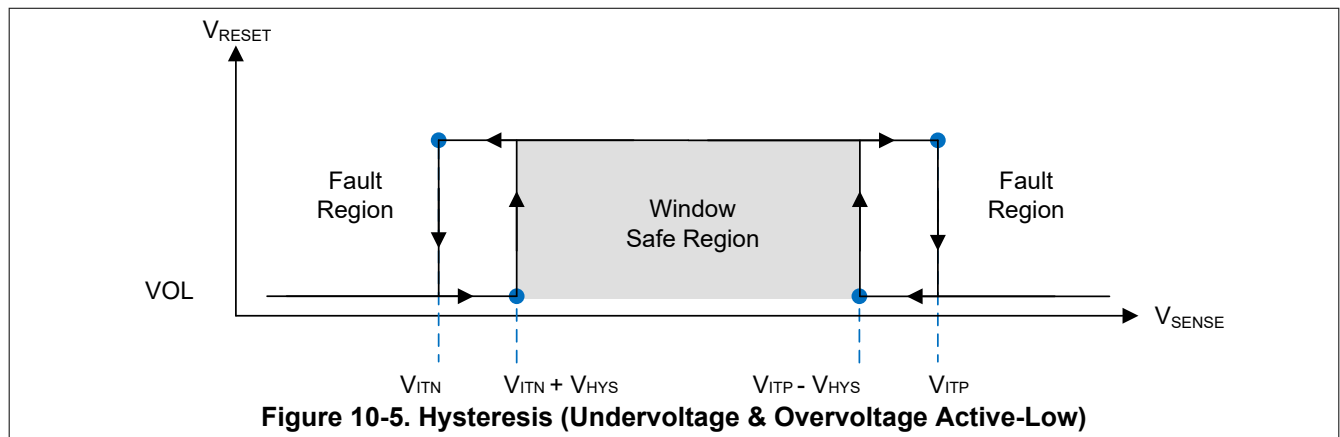

Table 10-1. Common Adjustable Hysteresis Lookup Table

ADJUSTABLE THRESHOLD	TARGET		DEVICE HYSTERESIS OPTION
	TOPOLOGY	RELEASE VOLTAGE (V)	
800mV	Overvoltage	784mV	-2%
800mV	Overvoltage	760mV	-5%
800mV	Overvoltage	720mV	-10%
800mV	Undervoltage	816mV	2%
800mV	Undervoltage	840mV	5%
800mV	Undervoltage	880mV	10%

Table 10-1 shows a sample of hysteresis for the 800mV adjustable variant of TPS3762-Q1.

Knowing the amount of hysteresis voltage, the release voltage for the undervoltage (UV) channel is ($V_{ITN} + V_{HYS}$) and for the overvoltage (OV) channel is ($V_{ITP} - V_{HYS}$).

Undervoltage (UV)

$$V_{ITN} = 800\text{mV}$$

$$\text{Voltage Hysteresis } (V_{HYS}) = 2\% = 16\text{mV}$$

$$\text{Hysteresis Accuracy} = +1.5\% \text{ to } +2.5\% = 16.24\text{mV to } 16.4\text{mV}$$

$$\text{Release Voltage} = V_{ITN} + V_{HYS} = 816.24\text{mV to } 816.4\text{mV}$$

Overvoltage (OV)

$$V_{ITP} = 800\text{mV}$$

$$\text{Voltage Hysteresis } (V_{HYS}) = 2\% = 16\text{mV}$$

$$\text{Hysteresis Accuracy} = +1.5\% \text{ to } +2.5\% = 16.24\text{mV to } 16.4\text{mV}$$

$$\text{Release Voltage} = V_{ITP} - V_{HYS} = 783.6\text{mV to } 783.76\text{mV}$$

10.3.3 Output Logic Configurations

TPS3762-Q1 is a single channel device that has a single input SENSE pin and a single $\overline{\text{RESET}}$ pin. The single $\overline{\text{RESET}}$ is available only with open drain topology.

10.3.3.1 Open-Drain

Open-drain output requires an external pull-up resistor to hold the voltage high to the required voltage logic. Connect the pull-up resistor to the proper voltage rail to enable the output to be connected to other devices at the correct interface voltage levels.

To select the right pull-up resistor consider system V_{OH} and the Open-Drain Leakage Current (I_{IKG}) provided in the electrical characteristics, high resistors values will have a higher voltage drop affecting the output voltage high. The open-drain output can be connected as a wired-AND logic with other open-drain signals such as another TPS3762-Q1 open-drain output pin.

10.3.3.2 Active-Low ($\overline{\text{RESET}}$)

$\overline{\text{RESET}}$ (active low) denoted with a bar above the pin label. $\overline{\text{RESET}}$ remains high voltage (V_{OH} , deasserted) as long as sense voltage is in normal operation within the threshold boundaries and VDD voltage is above UVLO. To assert a reset sense pins needs to meet the condition below:

- For undervoltage the SENSE voltage need to cross the lower boundary (V_{ITN}).
- For overvoltage the SENSE voltage needs to cross the upper boundary (V_{ITP}).

10.3.3.3 Latching

The TPS3762-Q1 comes with the optional output reset latching feature, check the [Section 5](#) to verify variant specific latch functionality. When using a variant with latch enabled ($V_{\text{BIST_EN/LATCH_CLR}} < 0.5\text{V}$), whenever a fault, OV or UV, occurs $\overline{\text{RESET}}$ asserts and goes low and remains low until cleared by a logic high input ($V_{\text{BIST_EN/LATCH_CLR}} > 1.3\text{V}$) on the BIST_EN / LATCH_CLR pin. If the SENSE pin is in a safe region and latch is disabled, the $\overline{\text{RESET}}$ deasserts after a delay. This delay is dependent on BIST and CTR timing. See [Section 10.3.6](#) for more details. While $V_{\text{BIST_EN/LATCH_CLR}} > 1.3\text{V}$, the device is in latch disabled mode and the $\overline{\text{RESET}}$ does not latch for OV and UV on SENSE pin. While the device is in latch disabled mode the $\overline{\text{RESET}}$ asserts for OV and UV faults. When $V_{\text{BIST_EN/LATCH_CLR}} < 0.5\text{V}$, latch mode is enabled.

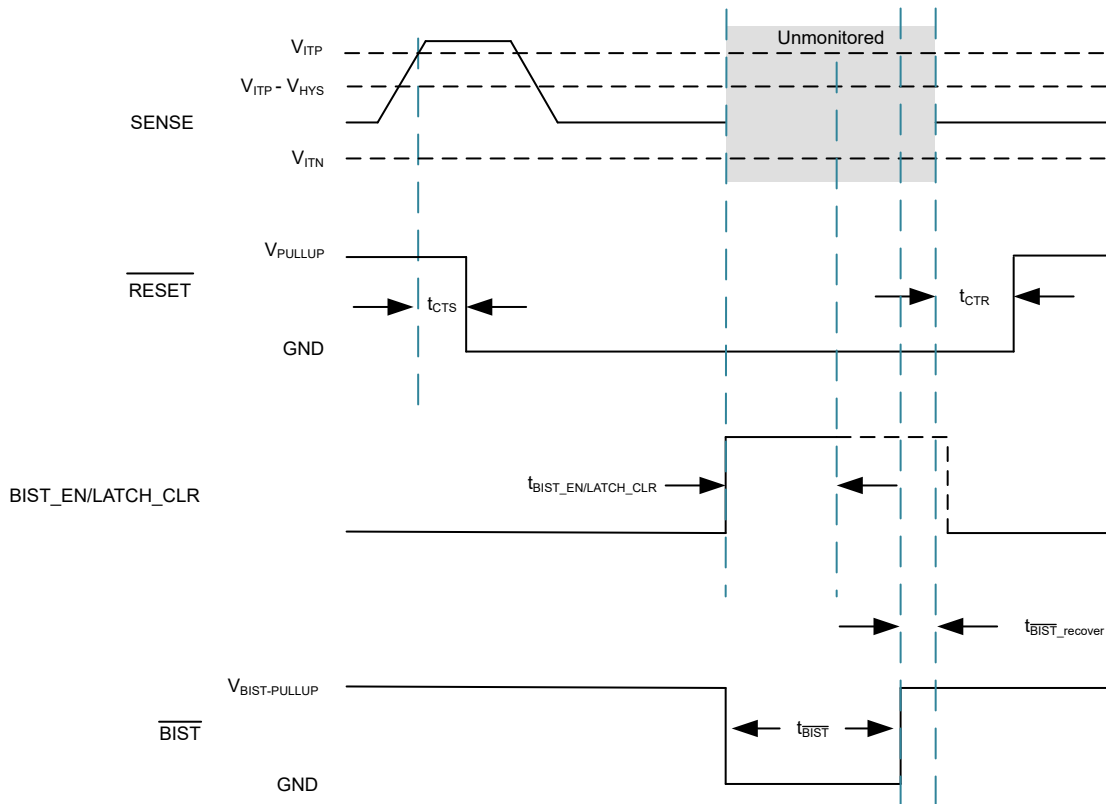

Figure 10-6. $\overline{\text{RESET}}$ Latch & Unlatch

10.3.3.4 UVBypass

The TPS3762-Q1 comes with the optional undervoltage bypass (UVbypass) feature, check [Section 5](#) to verify variant specific UVbypass functionality. When using a variant with UVbypass enabled, the first undervoltage event after $V_{DD} > V_{POR}$ is ignored. In cases where an undervoltage event has not occurred UVbypass can be cleared by running BIST.

UVbypass is targeted at specific applications in which the TPS3762-Q1 is powered Off-battery and is monitoring the Off-battery DC-DC output, as shown in [Figure 10-7](#). If the Off-battery DCDC output is outside of threshold the TPS3762-Q1 resets this device. See [Figure 10-8](#) and [Figure 10-9](#) for more details.

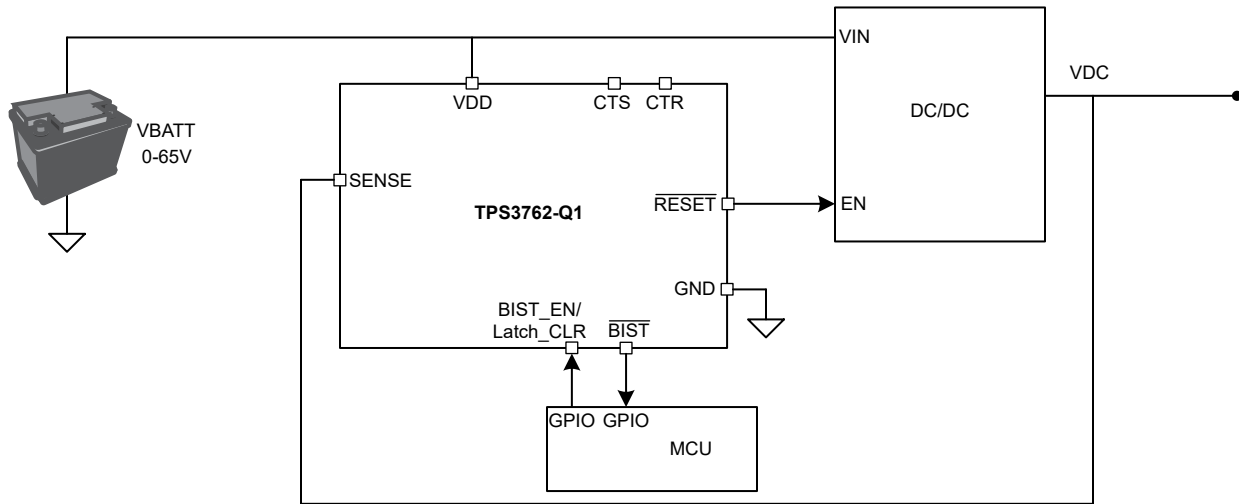

Figure 10-7. UVbypass Schematic

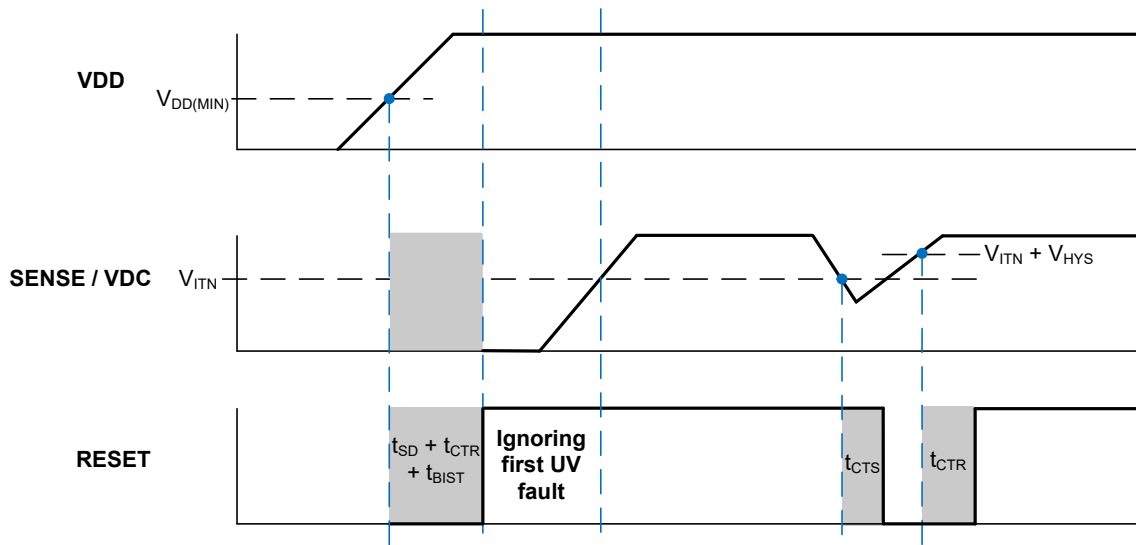

Figure 10-8. UVbypass Enabled

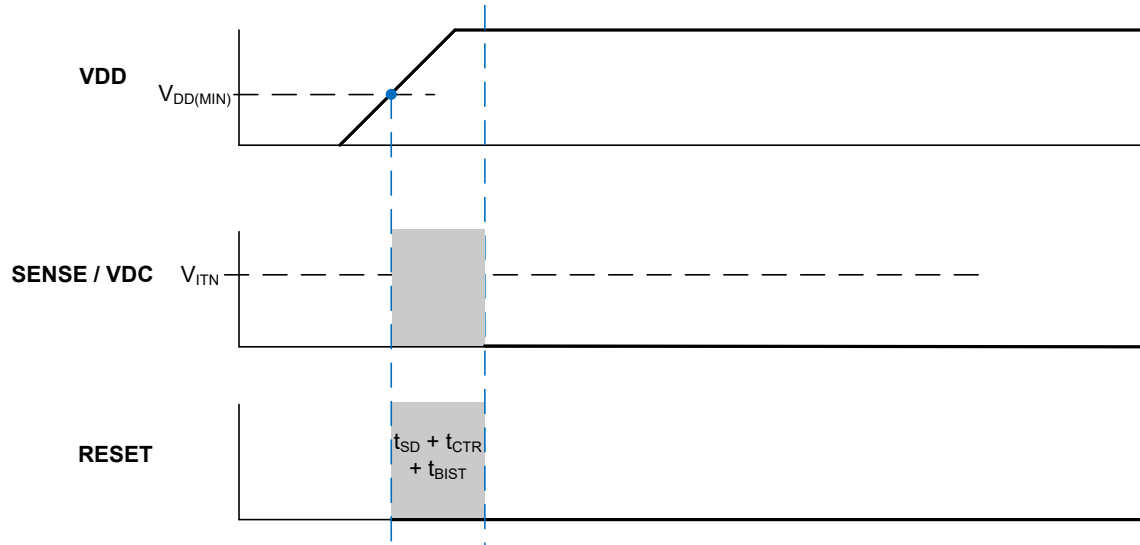

Figure 10-9. UVbypass Disabled

10.3.4 User-Programmable Reset Time Delay

TPS3762-Q1 has adjustable reset release time delay with external capacitors.

- A capacitor on CTR programs the reset time delay of the output.
- No capacitor on this pin gives the fastest reset delay time indicated by t_{CTR} in [Section 7.6](#).
- Variants such as TPS3762Q use a fixed internal time delay. check the [Section 5](#) to verify variant specific timing.

10.3.4.1 Reset Time Delay Configuration

RESET time delay (t_{CTR}) occurs when the \overline{RESET} is transitioning from a fault state (V_{OL}) to a non-fault state (V_{OH}). The time delay (t_{CTR}) can be programmed by connecting a capacitor between CTR pin and GND. For situations with a fault on SENSE after \overline{RESET} recovers, the TPS3762-Q1 makes sure that the CTR capacitor is fully discharged before starting the recovery sequence. This makes sure that the programmed CTR time is maintained for consecutive faults.

The relationship between external capacitor $C_{CTR_EXT (typ)}$ and the time delay $t_{CTR (typ)}$ is given by [Equation 1](#).

$$t_{CTR (typ)} = R_{CTR (typ)} \times C_{CTR_EXT (typ)} + t_{CTR (no\ cap)} \times 10^{-6} \quad (1)$$

$R_{CTR (typ)}$ = is in mega ohms (MΩ)

$C_{CTR_EXT (typ)}$ = is given in microfarads (μF)

$t_{CTR (typ)}$ = is the reset time delay/delays

The reset delay varies according to three variables: the external capacitor (C_{CTR_EXT}), CTR pin internal resistance (R_{CTR}) provided in [Section 7.5](#), and the constant ($t_{CTR (no\ cap)}$) provided in [Section 7.6](#). The minimum and maximum variance due to the constant is show in [Equation 2](#) and [Equation 3](#):

$$t_{CTR (min)} = R_{CTR (min)} \times C_{CTR_EXT (min)} + t_{CTR (no\ cap (min))} \times 10^{-6} \quad (2)$$

$$t_{CTR (max)} = R_{CTR (max)} \times C_{CTR_EXT (max)} + t_{CTR (no\ cap (max))} \times 10^{-6} \quad (3)$$

There is no limit to the capacitor on CTR pin. Having a too large of a capacitor value can cause very slow charge up (rise times) due to capacitor leakage and system noise can cause the internal circuit to hold \overline{RESET} active.

* Leakages on the capacitor can effect accuracy of reset time delay.

10.3.5 User-Programmable Sense Delay

TPS3762-Q1 has adjustable sense release time delay with external capacitors.

- A capacitor on CTS programs the sense time delay of the input.
- No capacitor on this pin gives the fastest sense delay time indicated by t_{CTS} in [Section 7.7](#).
- The TPS3762-Q1 comes with an optional fixed internal time delay that ignores the capacitor value at the CTS pin, check the [Section 5](#) to verify variant specific functionality.

10.3.5.1 Sense Time Delay Configuration

SENSE time delay (t_{CTS}) occurs when the \overline{RESET} is transitioning from a non-fault state (V_{OH}) to a fault state (V_{OL}). The time delay (t_{CTS}) can be programmed by connecting a capacitor between CTS pin and GND.

The relationship between external capacitor $C_{CTS_EXT (typ)}$ and the time delay $t_{CTS (typ)}$ is given by [Equation 4](#).

$$t_{CTS (typ)} = R_{CTS (typ)} \times C_{CTS_EXT (typ)} + t_{CTS (no\ cap)} \times 10^{-6} \quad (4)$$

$R_{CTS (typ)}$ = is in mega ohms (M Ω)

$C_{CTS_EXT (typ)}$ = is given in microfarads (μ F)

$t_{CTS (typ)}$ = is the sense time delay/delays

The sense delay varies according to three variables: the external capacitor (C_{CTS_EXT}), CTS pin internal resistance (R_{CTS}) provided in [Section 7.5](#), and the constant ($t_{CTS (no\ cap)}$) provided in [Section 7.6](#). The minimum and maximum variance due to the constant is show in [Equation 5](#) and [Equation 6](#):

$$t_{CTS (min)} = R_{CTS (min)} \times C_{CTS_EXT (min)} + t_{CTS (no\ cap (min))} \times 10^{-6} \quad (5)$$

$$t_{CTS (max)} = R_{CTS (max)} \times C_{CTS_EXT (max)} + t_{CTS (no\ cap (max))} \times 10^{-6} \quad (6)$$

The recommended maximum sense delay capacitor for the TPS3762-Q1 is 10 μ F as this makes sure there is enough time for the capacitor to fully discharge when a voltage fault occurs. Also, having a too large of a capacitor value can cause very slow charge up (rise times) and system noise can cause the internal circuit to trip unpredictably. This leads to a variation in time delay where the delay accuracy can be worse in the presence of system noise.

* Leakages on the capacitor can effect accuracy of sense time delay.

10.3.6 Built-In Self-Test

The TPS3762-Q1 has a Built-In Self-Test (BIST) feature that runs diagnostics internally in the device. During power-up BIST is initiated automatically after crossing $V_{DD(min)}$. During BIST the \overline{BIST} pin and \overline{RESET} output asserts low and deasserts if the \overline{BIST} test completes successfully indicating no internal faults in the device. The length of the BIST and \overline{BIST} assertion is specified by t_{BIST} . If BIST is not successful, the \overline{BIST} pin will stay asserted low signifying an internal fault. The \overline{RESET} output will stay assert on \overline{BIST} failure. During BIST, the device is not monitoring the SENSE pin for faults and the \overline{RESET} is not dependent on the SENSE pin voltage. The \overline{BIST} sequence of internal tests verifies the internal signal chain of the device by checking for faults on the internal comparators on the SENSE pin, bandgap voltage, and the \overline{RESET} output. See [Figure 10-10](#) for more details.

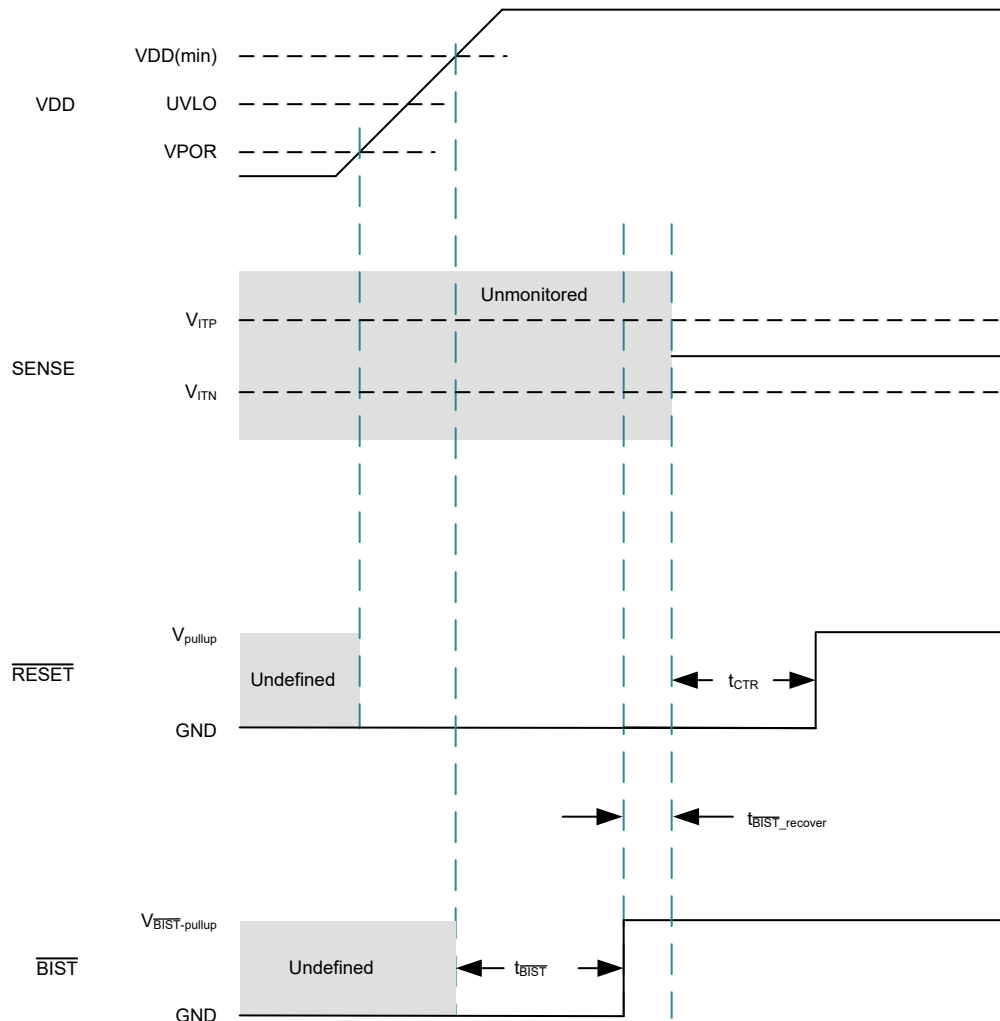

Figure 10-10. TPS3762-Q1 Start-Up Sequence

After a successful power-up sequence, BIST can be initiated any time with a logic high input (V_{BIST_EN} or $V_{BIST_EN/LATCH_CLR} > 1.3V$) on the BIST_EN / LATCH_CLR pin. BIST initiates and the \overline{BIST} pin asserts only if the SENSE pin is not in a overvoltage or undervoltage fault mode. During this BIST test time period, t_{BIST} , \overline{BIST} pin asserts low to signify that \overline{BIST} has started and \overline{RESET} assertion is dependent on the device variant. Upon a successful BIST the \overline{BIST} pin and \overline{RESET} pin are deasserted. If BIST is not successful due to an internal device not working properly, the \overline{RESET} pin and \overline{BIST} pin remain asserted low signifying a fault internal to the device. See [Figure 10-11](#) and [Figure 10-12](#) for more details.

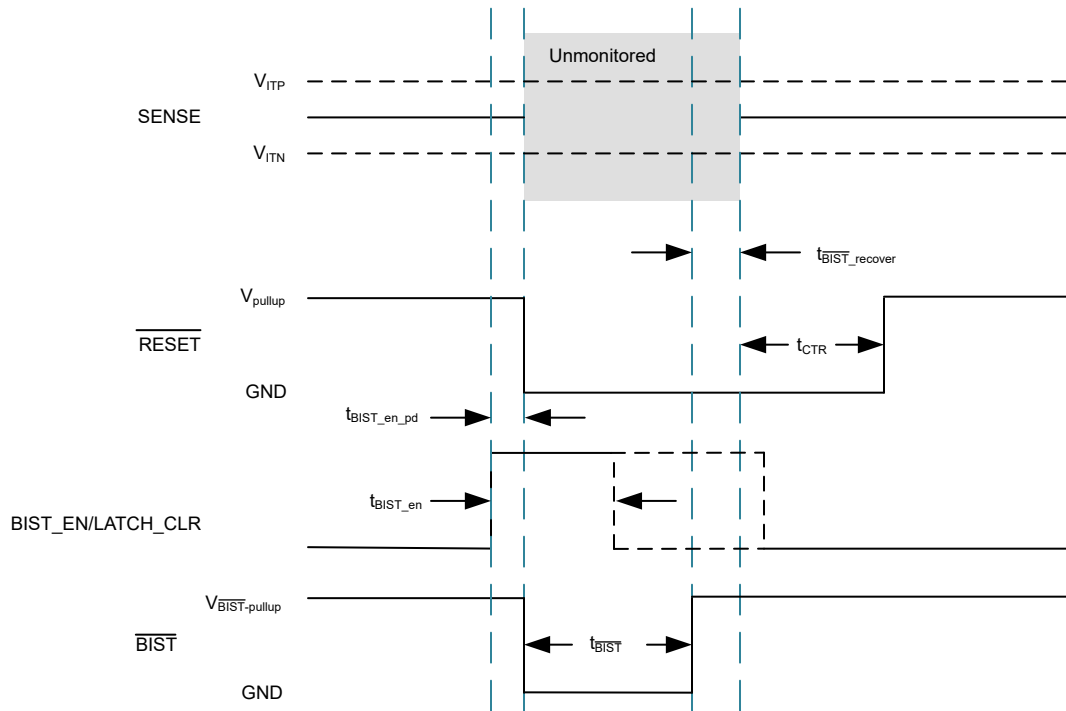

Figure 10-11. BIST With RESETE Assertion

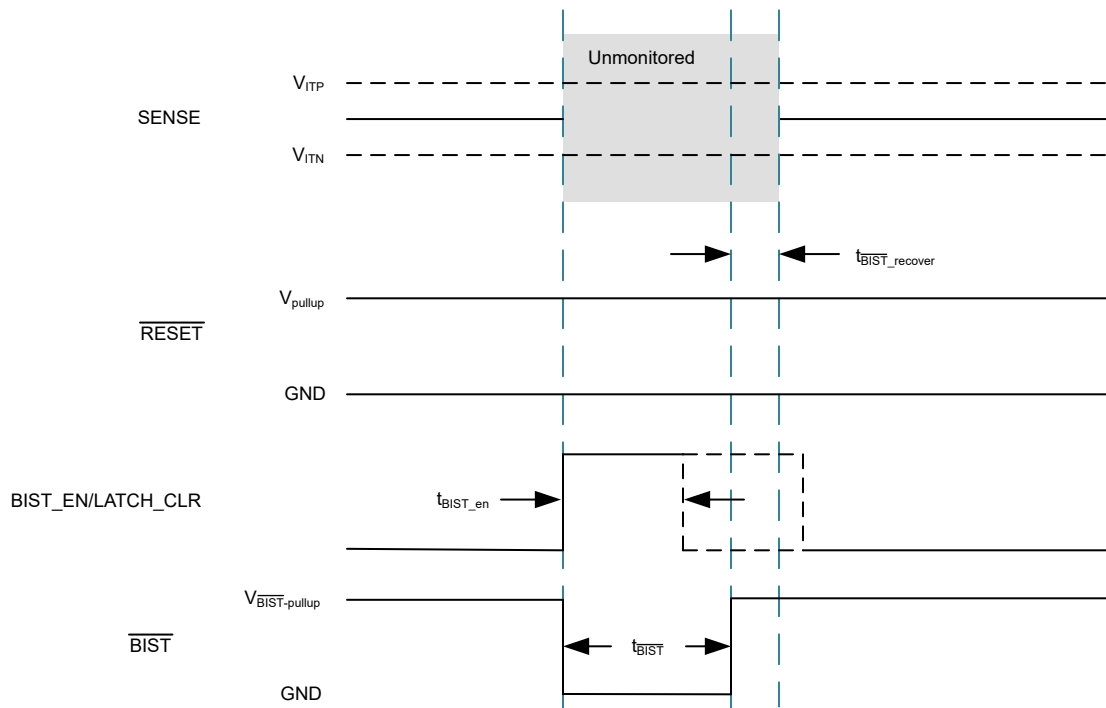

Figure 10-12. BIST With No RESETE Assertion

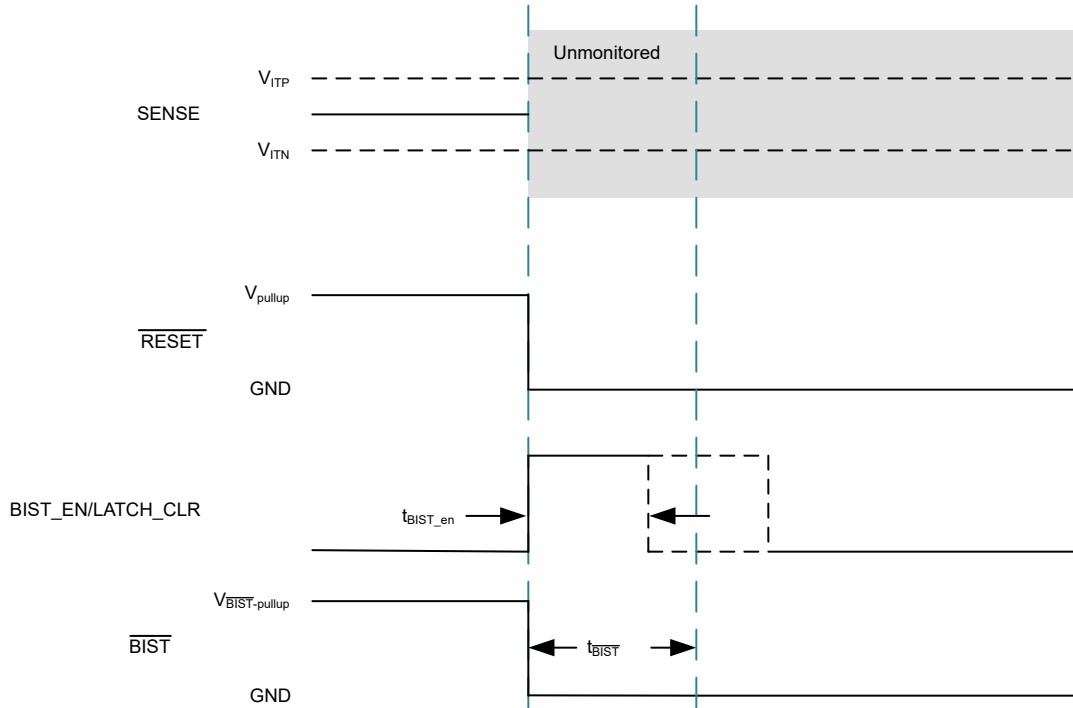

Figure 10-13. $\overline{\text{BIST}}$ Fail With $\overline{\text{RESET}}$ Assertion

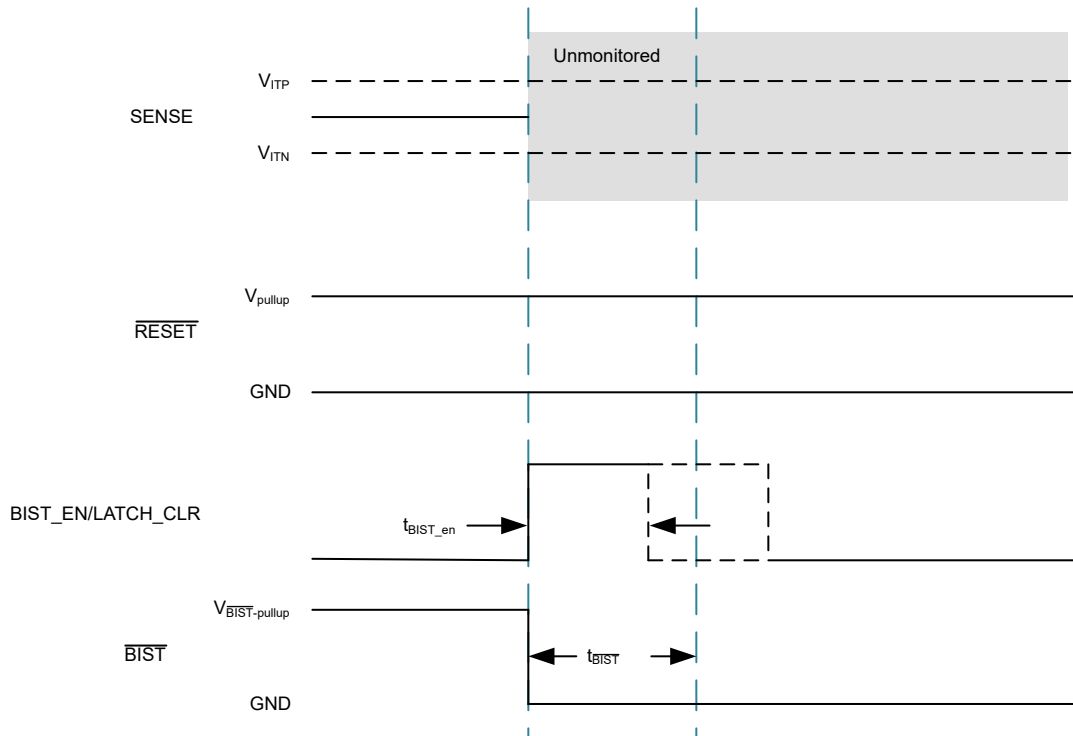

Figure 10-14. $\overline{\text{BIST}}$ Fail With No $\overline{\text{RESET}}$ Assertion

10.4 Device Functional Modes

Table 10-2. Undervoltage Detect Functional Mode Truth Table

DESCRIPTION	SENSE		CTR ⁽¹⁾ / MR PIN	V _{DD} PIN	OUTPUT ⁽²⁾ (RESET PIN)
	PREVIOUS CONDITION	CURRENT CONDITION			
Normal Operation	SENSE > V _{ITN}	SENSE > V _{ITN}	Open or capacitor connected	V _{DD} > V _{DD(MIN)}	High
Undervoltage Detection	SENSE > V _{ITN}	SENSE < V _{ITN}	Open or capacitor connected	V _{DD} > V _{DD(MIN)}	Low
Undervoltage Detection	SENSE < V _{ITN}	SENSE > V _{ITN}	Open or capacitor connected	V _{DD} > V _{DD(MIN)}	Low
Normal Operation	SENSE < V _{ITN}	SENSE > V _{ITN} + HYS	Open or capacitor connected	V _{DD} > V _{DD(MIN)}	High
UVLO Engaged	SENSE > V _{ITN}	SENSE > V _{ITN}	Open or capacitor connected	V _{POR} < V _{DD} < V _{DD(MIN)}	Low
Below V _{POR} , Undefined Output	SENSE > V _{ITN}	SENSE > V _{ITN}	Open or capacitor connected	V _{DD} < V _{POR}	Undefined

(1) Reset time delay is ignored in the truth table.

(2) Open-drain active low output requires an external pull-up resistor to a pull-up voltage.

Table 10-3. Overvoltage Detect Functional Mode Truth Table

DESCRIPTION	SENSE		CTR ⁽¹⁾ / MR PIN	V _{DD} PIN	OUTPUT ⁽²⁾ (RESET PIN)
	PREVIOUS CONDITION	CURRENT CONDITION			
Normal Operation	SENSE < V _{ITN}	SENSE < V _{ITN}	Open or capacitor connected	V _{DD} > V _{DD(MIN)}	High
Overvoltage Detection	SENSE < V _{ITN}	SENSE > V _{ITN}	Open or capacitor connected	V _{DD} > V _{DD(MIN)}	Low
Overvoltage Detection	SENSE > V _{ITN}	SENSE < V _{ITN}	Open or capacitor connected	V _{DD} > V _{DD(MIN)}	Low
Normal Operation	SENSE > V _{ITN}	SENSE < V _{ITN} - HYS	Open or capacitor connected	V _{DD} > V _{DD(MIN)}	High
UVLO Engaged	SENSE < V _{ITN}	SENSE < V _{ITN}	Open or capacitor connected	V _{POR} < V _{DD} < UVLO	Low
Below V _{POR} , Undefined Output	SENSE < V _{ITN}	SENSE < V _{ITN}	Open or capacitor connected	V _{DD} < V _{POR}	Undefined

(1) Reset time delay is ignored in the truth table.

(2) Open-drain active low output requires an external pull-up resistor to a pull-up voltage.

11 Application and Implementation

Note

Information in the following applications sections is not part of the TI component specification, and TI does not warrant its accuracy or completeness. TI's customers are responsible for determining suitability of components for their purposes, as well as validating and testing their design implementation to confirm system functionality.

11.1 Application Information

The following sections describe in detail proper device implementation, depending on the final application requirements.

11.2 Adjustable Voltage Thresholds

Figure 11-1 illustrates an example of how to adjust the voltage threshold with external resistor dividers. The resistors can be calculated depending on the desired voltage threshold and device part number. TI recommends using the adjustable (0.8V voltage threshold device) when setting adjustable voltage thresholds. This variant bypasses the internal resistor ladder.

For example, consider a 12V rail, V_{MON} , being monitored for overvoltage (OV) using of the TPS3762D02OVDDFRQ1 variant, as shown in Figure 11-1. The monitored OV threshold, denoted as V_{MON+} , is the desired voltage where the device asserts the reset. For this example $V_{MON+} = 35V$. To assert an overvoltage reset the voltage at the sense pin, V_{SENSE} , needs to be equal to the input threshold positive, V_{ITP} . For this example variant $V_{SENSE} = V_{ITP} = 0.8V$. Using R_1 and R_2 the correlation between V_{MON+} and V_{SENSE} can be seen in Equation 8. Assuming $R_2 = 10k\Omega$, and R_1 can be calculated as $R_1 = 427.5k\Omega$.

$$V_{SENSE} = V_{MON+} \times (R_2 \div (R_1 + R_2)) \quad (7)$$

The TPS3762D02OVDDFRQ1 comes with variant specific 2%, 5%, or 10% voltage threshold hysteresis. For the reset signal to become deasserted, V_{MON} must go below $V_{ITP} - V_{HYS}$. For this example variant a 2% voltage threshold hysteresis was selected. Therefore, V_{MON} equals 34.3V when the reset signal becomes deasserted.

There are inaccuracies that must be taken into consideration while adjusting voltage thresholds. Aside from the tolerance of the resistor divider, there is the internal resistance of the SENSE pin that can affect the accuracy of the resistor divider. Although expected to be very high impedance, users are recommended to calculate the values for the design specifications. The internal SENSE resistance (R_{SENSE}) can be calculated by the SENSE voltage (V_{SENSE}) divided by the SENSE current (I_{SENSE}) as shown in Equation 9. V_{SENSE} can be calculated using Equation 7 depending on the resistor divider and monitored voltage. I_{SENSE} can be calculated using Equation 8.

$$I_{SENSE} = [(V_{MON} - V_{SENSE}) \div R_1] - (V_{SENSE} \div R_2) \quad (8)$$

$$R_{SENSE} = V_{SENSE} \div I_{SENSE} \quad (9)$$

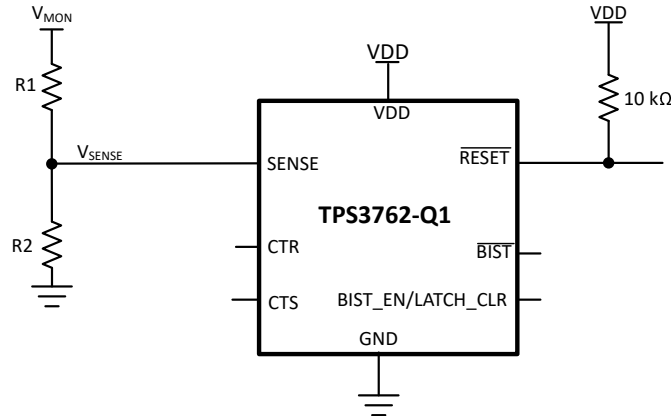

Figure 11-1. Adjustable Voltage Threshold with External Resistor Dividers

11.3 Typical Application

11.3.1 Design 1: Off-Battery Monitoring

This application is intended for the initial power stage in applications with the 12V batteries. The TPS3762-Q1 utilizes high-voltage SENSE and V_{DD} inputs to monitor an automotive battery.

Figure 11-6 illustrates an example of how the TPS3762-Q1 is monitoring the battery voltage while being powered by it, as well.

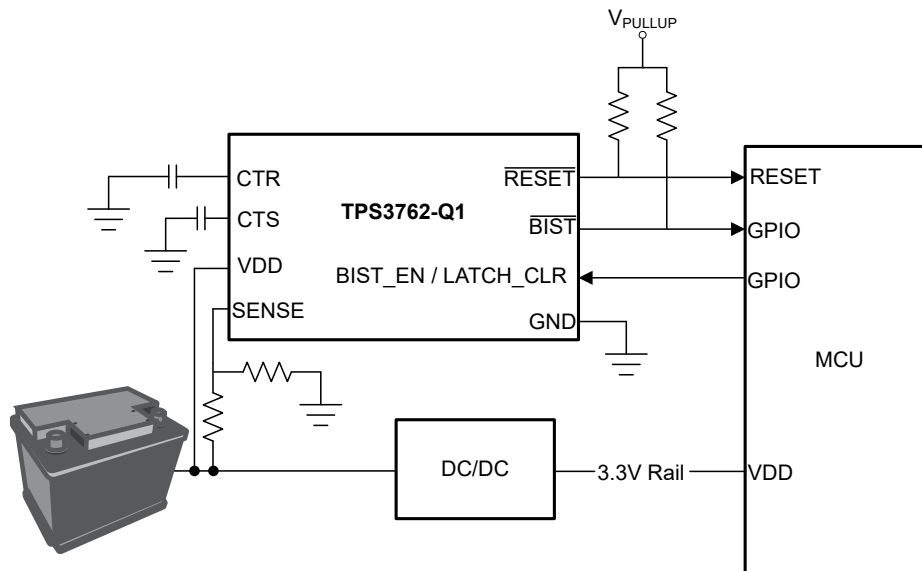

Figure 11-2. Off-Battery Monitoring

11.3.1.1 Design Requirements

Table 11-1. Design Parameters

PARAMETER	DESIGN REQUIREMENT
Voltage Threshold	Typical OV voltage threshold 30V.
Maximum Input Power	Operate with power supply input up to 65V
Output Logic	Open-Drain
SENSE Delay	>100ms
RESET Delay	>300ms
Output Features	Output latching and built-in self-test

11.3.1.2 Detailed Design Procedure

The TPS3762-Q1 utilizes high-voltage SENSE and V_{DD} inputs to monitor an automotive battery. In this design example TPS3762D02OVDDFRQ1 is used.

11.3.1.2.1 Setting Voltage Threshold

The positive-going threshold voltage, V_{ITP} , is set by the device variant. In this example, the nominal supply voltage from the battery is 12V. Setting a overvoltage threshold of 30V makes sure that the device resets before supply voltage violates the allowed boundary. The adjustable voltage variant is chosen and R_1 and R_2 are adjusted to meet the threshold. Assuming R_2 equal to 10k Ω and R_1 is calculated as 365k Ω . For additional information on selecting resistor values see [Section 11.2](#). TPS3762-Q1 also supports fixed voltage threshold variants. Threshold voltage decoding can be found in [Device Decoder](#).

11.3.1.2.2 Meeting the Sense and Reset Delay

The TPS3762-Q1 features both reset assertion (sense) delay, t_{CTS} , and reset deassertion (reset) delay, t_{CTR} . The TPS3762-Q1 features two options for selecting sense and reset delays: fixed delays and capacitor-programmable delays. For the device variant used in this design, TPS3762D02OVDDFRQ1, the capacitor programmable delay is chosen. [Section 10.3.5](#) and [Section 10.3.4](#) show how to set the timings for the capacitor-programmable delays. The application requires greater than 100 ms sense delay, thus a 0.033 μ F capacitor is used. The application requires greater than 300 ms reset delay, thus a 0.1 μ F capacitor is used.

11.3.1.2.3 Setting Supply Voltage

Setting the supply voltage is done by connecting the V_{DD} input directly to the battery rail without the need for external circuitry. The device being able to handle 65V on V_{DD} means the monitored voltage rail can handle any voltage transience up to 65V. Good analog design practice recommends using a 0.1 μ F capacitor on the V_{DD} pin.

11.3.1.2.4 Initiating Built-In Self-Test and Clearing Latch

Built-In Self-Test (BIST) is asserted on device power-up, as outlined in [Figure 10-10](#). BIST can also be initiated any time by a rising edge that crosses the voltage logic high input (V_{BIST_EN} or $V_{BIST_EN/LATCH_CLR} > 1.3V$) on the BIST_EN / LATCH_CLR pin, as outlined in [Figure 10-11](#). Output reset latching is set by the device variant. For the device variant used in this design, TPS3762D02OVDDFRQ1, the output has latch. Device specific output reset latching feature can be found in [Device Decoder](#). To clear the latch a logic high input on the BIST_EN / LATCH_CLR pin is required. When clearing latch, BIST is initiated and the RESET returns logic level high once $t_{BIST} + t_{BIST_recover} + t_{CTR}$ has expired, outlined in [Figure 10-6](#). While $V_{BIST_EN/LATCH_CLR} > 1.3V$, the device is in latch disabled mode and the RESET does not latch for OV and UV on SENSE pin. While the device is in latch disabled mode the RESET still asserts for OV and UV faults.

11.3.1.3 Application Curves

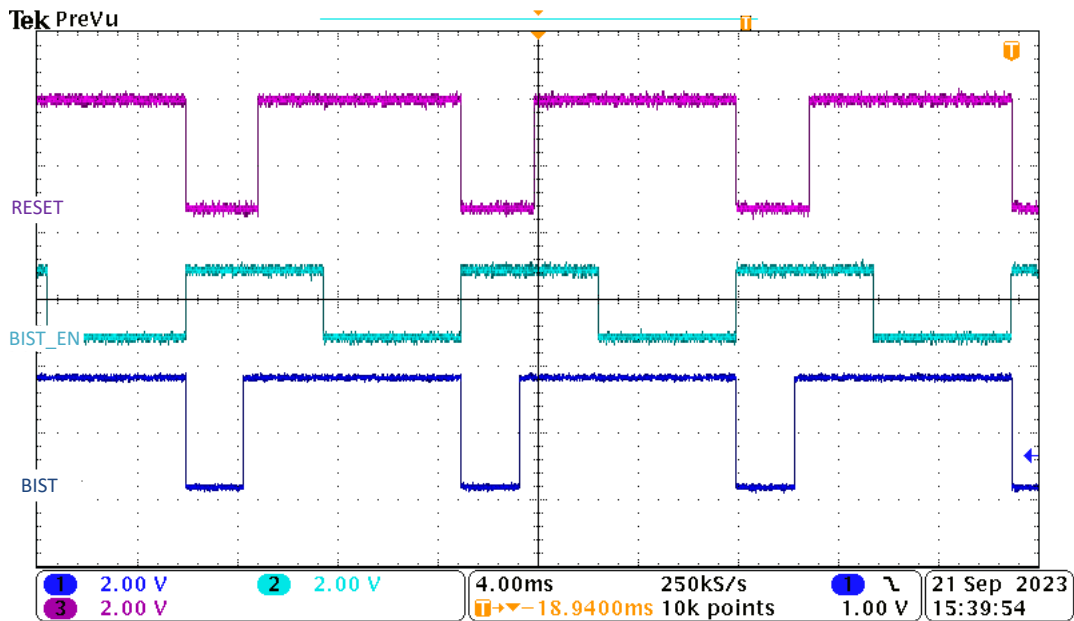

Figure 11-3. BIST with $\overline{\text{RESET}}$ Assertion Waveform

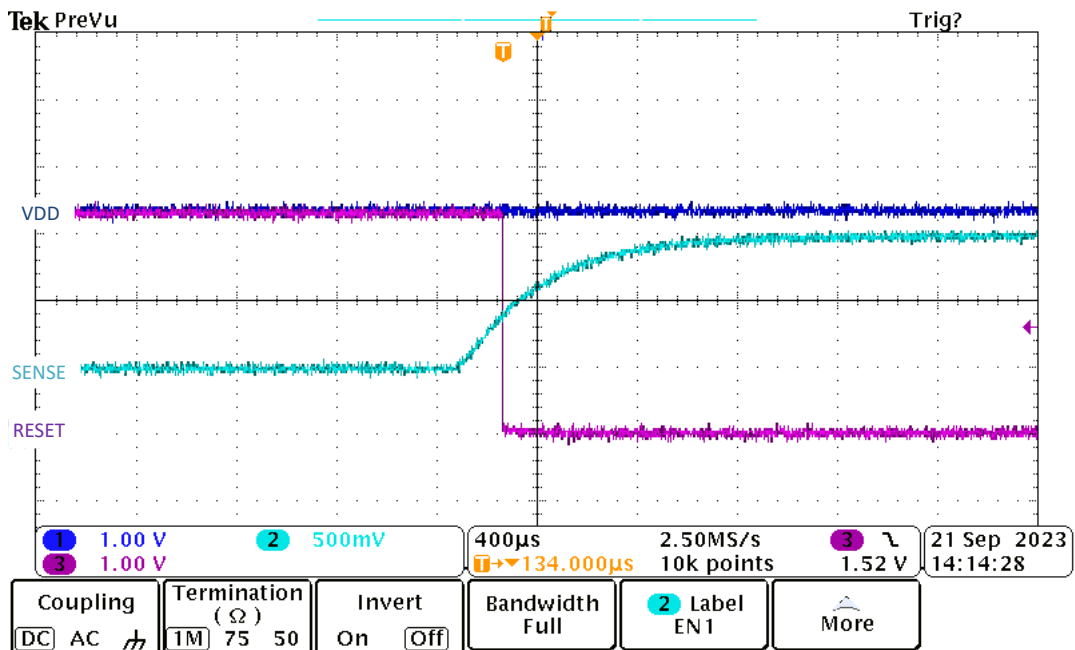

Figure 11-4. Overvoltage $\overline{\text{RESET}}$ Latching Waveform

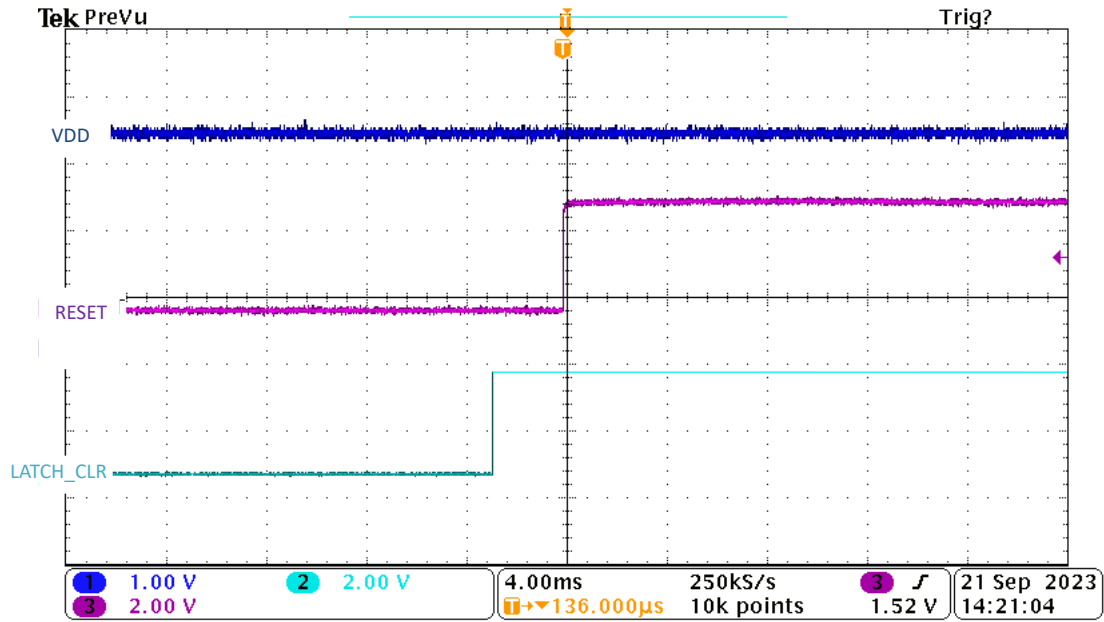

Figure 11-5. Overvoltage $\overline{\text{RESET}}$ Unlatching Waveform

11.4 Power Supply Recommendations

TPS3762-Q1 is designed to operate from an input supply with a V_{DD} voltage between 2.7V (minimum operation) to 65V (maximum operation). Good analog design practice recommends placing a minimum 0.1 μ F ceramic capacitor as near as possible to the V_{DD} pin.

11.4.1 Power Dissipation and Device Operation

The permissible power dissipation for any package is a measure of the capability of the device to pass heat from the power source, the junctions of the IC, to the ultimate heat sink, the ambient environment. Thus, the power dissipation is dependent on the ambient temperature and the thermal resistance across the various interfaces between the die junction and ambient air.

The maximum continuous allowable power dissipation for the device in a given package can be calculated using [Equation 10](#):

$$P_{D-MAX} = ((T_{J-MAX} - T_A) / R_{\theta JA}) \quad (10)$$

The actual power being dissipated in the device can be represented by [Equation 11](#):

$$P_D = V_{DD} \times I_{DD} + P_{RESET} \quad (11)$$

P_{RESET} is calculated by [Equation 12](#) or [Equation 13](#)

$$P_{RESET (PUSH/PULL)} = V_{DD} - V_{RESET} \times I_{RESET} \quad (12)$$

$$P_{RESET (OPEN-DRAIN)} = V_{RESET} \times I_{RESET} \quad (13)$$

[Equation 10](#) and [Equation 11](#) establish the relationship between the maximum power dissipation allowed due to thermal consideration, the voltage drop across the device, and the continuous current capability of the device. These two equations must be used to determine the optimum operating conditions for the device in the application.

In applications where lower power dissipation (P_D) and/or excellent package thermal resistance ($R_{\theta JA}$) is present, the maximum ambient temperature (T_{A-MAX}) can be increased.

In applications where high power dissipation and/or poor package thermal resistance is present, the maximum ambient temperature (T_{A-MAX}) may have to be de-rated. T_{A-MAX} is dependent on the maximum operating junction temperature ($T_{J-MAX-OP} = 125^\circ\text{C}$), the maximum allowable power dissipation in the device package in the application (P_{D-MAX}), and the junction-to ambient thermal resistance of the part/package in the application ($R_{\theta JA}$), as given by [Equation 14](#):

$$T_{A-MAX} = (T_{J-MAX-OP} - (R_{\theta JA} \times P_{D-MAX})) \quad (14)$$

11.5 Layout

11.5.1 Layout Guidelines

- Make sure that the connection to the VDD pin is low impedance. Good analog design practice is to place a greater than 0.1 μ F ceramic capacitor as near as possible to the VDD pin.
- To further improve the noise immunity on the SENSE pins, placing a 10nF to 100nF capacitor between the SENSE pin and GND can reduce the sensitivity to transient voltages on the monitored signal.
- If a capacitor is used on CTS or CTR, place these components as close as possible to the respective pins. If the capacitor adjustable pins are left unconnected, make sure to minimize the amount of parasitic capacitance on the pins to less than 5pF.
- Place the pull-up resistors on \overline{RESET} as close to the pin as possible.
- When laying out metal traces, separate high voltage traces from low voltage traces as much as possible. If high and low voltage traces need to run close by, spacing between traces must be greater than 20mils (0.5mm).

- Do not have high voltage metal pads or traces closer than 20 mils (0.5mm) to the low voltage metal pads or traces.

11.5.2 Layout Example

The layout example in [Figure 11-6](#) shows how the TPS3762-Q1 is laid out on a printed circuit board (PCB) with user-defined delays.

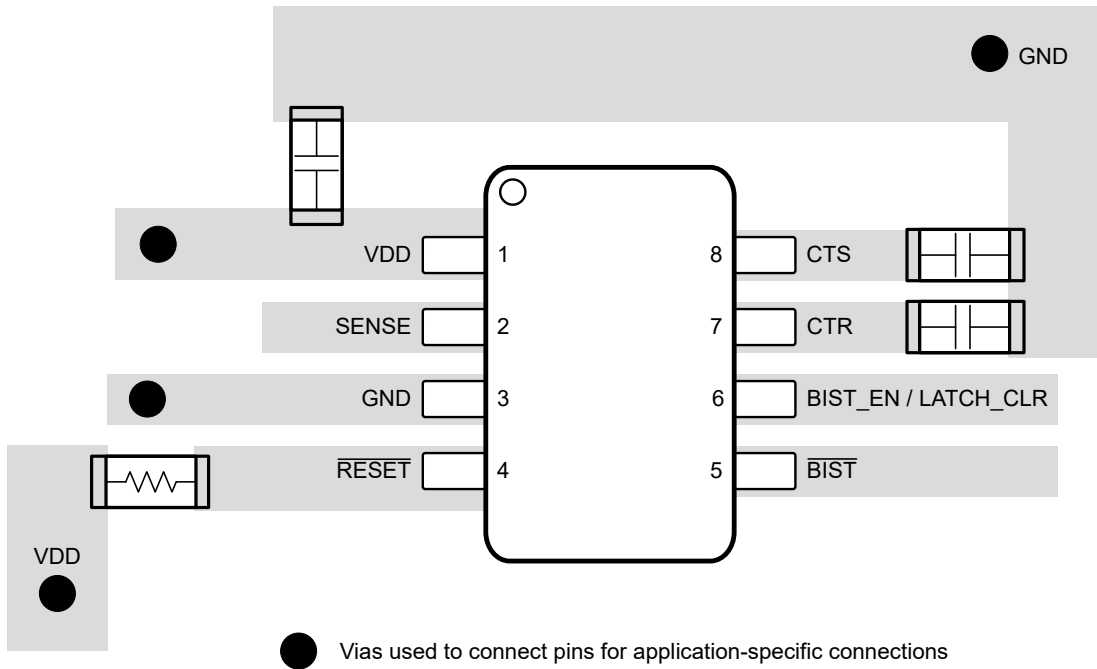

Figure 11-6. TPS3762-Q1 Recommended Layout

12 Device and Documentation Support

12.1 Receiving Notification of Documentation Updates

To receive notification of documentation updates, navigate to the device product folder on [ti.com](https://www.ti.com). Click on *Notifications* to register and receive a weekly digest of any product information that has changed. For change details, review the revision history included in any revised document.

12.2 Support Resources

[TI E2E™ support forums](#) are an engineer's go-to source for fast, verified answers and design help — straight from the experts. Search existing answers or ask your own question to get the quick design help you need.

Linked content is provided "AS IS" by the respective contributors. They do not constitute TI specifications and do not necessarily reflect TI's views; see TI's [Terms of Use](#).

12.3 Trademarks

TI E2E™ is a trademark of Texas Instruments.

All trademarks are the property of their respective owners.

12.4 Electrostatic Discharge Caution



This integrated circuit can be damaged by ESD. Texas Instruments recommends that all integrated circuits be handled with appropriate precautions. Failure to observe proper handling and installation procedures can cause damage.

ESD damage can range from subtle performance degradation to complete device failure. Precision integrated circuits may be more susceptible to damage because very small parametric changes could cause the device not to meet its published specifications.

12.5 Glossary

[TI Glossary](#) This glossary lists and explains terms, acronyms, and definitions.

13 Revision History

NOTE: Page numbers for previous revisions may differ from page numbers in the current version.

Changes from Revision * (October 2023) to Revision A (May 2024)	Page
• Production Data release.....	1

14 Mechanical, Packaging, and Orderable Information

The following pages include mechanical, packaging, and orderable information. This information is the most current data available for the designated devices. This data is subject to change without notice and revision of this document. For browser-based versions of this data sheet, refer to the left-hand navigation.

PACKAGING INFORMATION

Orderable Device	Status (1)	Package Type	Package Drawing	Pins	Package Qty	Eco Plan (2)	Lead finish/ Ball material (6)	MSL Peak Temp (3)	Op Temp (°C)	Device Marking (4/5)	Samples
PS3762D02OVDDFRQ1	ACTIVE	SOT-23-THIN	DDF	8	3000	TBD	Call TI	Call TI	-40 to 125		Samples

(1) The marketing status values are defined as follows:

ACTIVE: Product device recommended for new designs.

LIFEBUY: TI has announced that the device will be discontinued, and a lifetime-buy period is in effect.

NRND: Not recommended for new designs. Device is in production to support existing customers, but TI does not recommend using this part in a new design.

PREVIEW: Device has been announced but is not in production. Samples may or may not be available.

OBSELETE: TI has discontinued the production of the device.

(2) **RoHS:** TI defines "RoHS" to mean semiconductor products that are compliant with the current EU RoHS requirements for all 10 RoHS substances, including the requirement that RoHS substance do not exceed 0.1% by weight in homogeneous materials. Where designed to be soldered at high temperatures, "RoHS" products are suitable for use in specified lead-free processes. TI may reference these types of products as "Pb-Free".

RoHS Exempt: TI defines "RoHS Exempt" to mean products that contain lead but are compliant with EU RoHS pursuant to a specific EU RoHS exemption.

Green: TI defines "Green" to mean the content of Chlorine (Cl) and Bromine (Br) based flame retardants meet JS709B low halogen requirements of <=1000ppm threshold. Antimony trioxide based flame retardants must also meet the <=1000ppm threshold requirement.

(3) MSL, Peak Temp. - The Moisture Sensitivity Level rating according to the JEDEC industry standard classifications, and peak solder temperature.

(4) There may be additional marking, which relates to the logo, the lot trace code information, or the environmental category on the device.

(5) Multiple Device Markings will be inside parentheses. Only one Device Marking contained in parentheses and separated by a "~" will appear on a device. If a line is indented then it is a continuation of the previous line and the two combined represent the entire Device Marking for that device.

(6) Lead finish/Ball material - Orderable Devices may have multiple material finish options. Finish options are separated by a vertical ruled line. Lead finish/Ball material values may wrap to two lines if the finish value exceeds the maximum column width.

Important Information and Disclaimer:The information provided on this page represents TI's knowledge and belief as of the date that it is provided. TI bases its knowledge and belief on information provided by third parties, and makes no representation or warranty as to the accuracy of such information. Efforts are underway to better integrate information from third parties. TI has taken and continues to take reasonable steps to provide representative and accurate information but may not have conducted destructive testing or chemical analysis on incoming materials and chemicals. TI and TI suppliers consider certain information to be proprietary, and thus CAS numbers and other limited information may not be available for release.

In no event shall TI's liability arising out of such information exceed the total purchase price of the TI part(s) at issue in this document sold by TI to Customer on an annual basis.

DDF0008A



PACKAGE OUTLINE

SOT-23 - 1.1 mm max height

PLASTIC SMALL OUTLINE

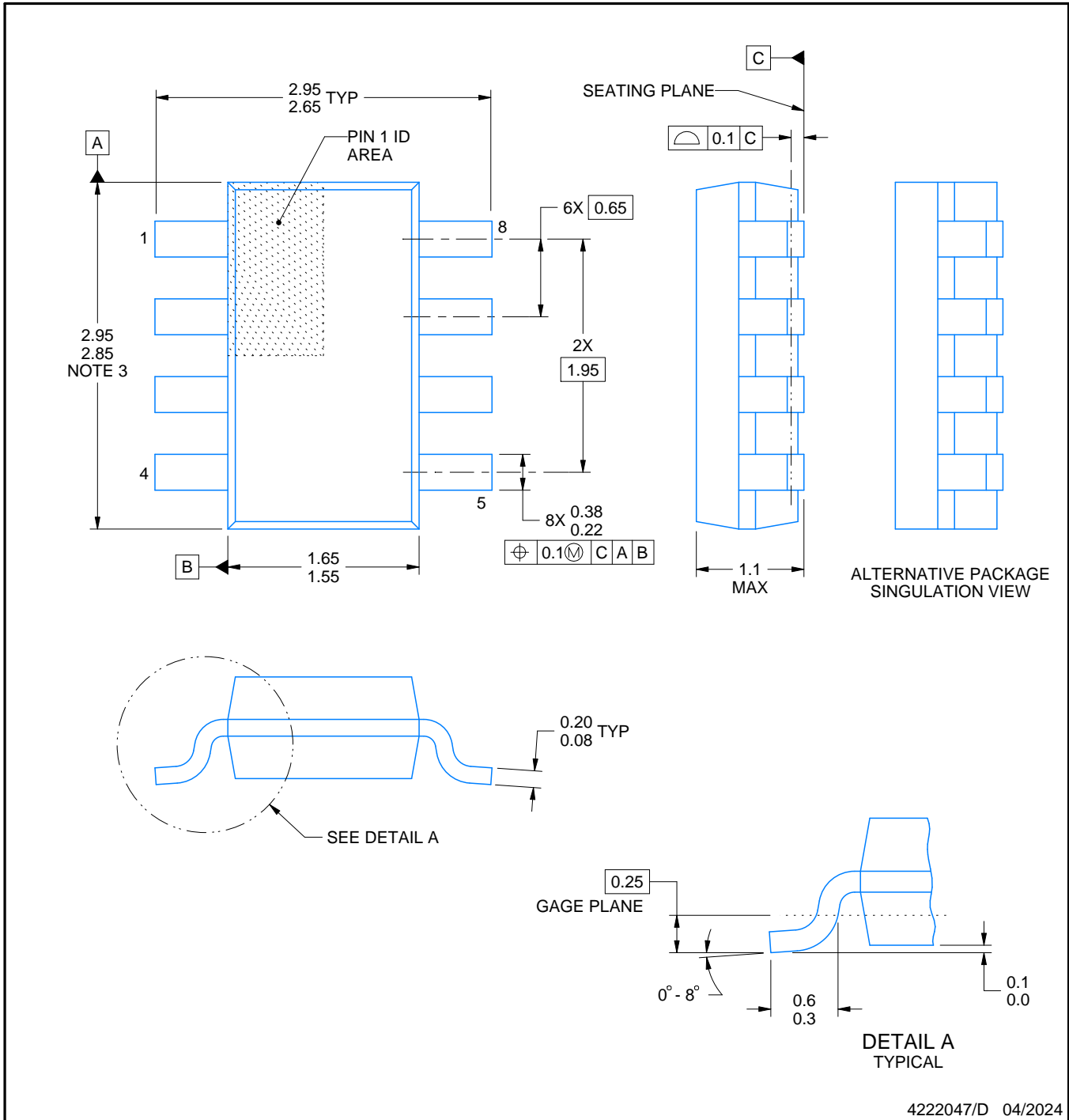

4222047/D 04/2024

NOTES:

1. All linear dimensions are in millimeters. Any dimensions in parenthesis are for reference only. Dimensioning and tolerancing per ASME Y14.5M.
2. This drawing is subject to change without notice.
3. This dimension does not include mold flash, protrusions, or gate burrs. Mold flash, protrusions, or gate burrs shall not exceed 0.15 mm per side.

EXAMPLE BOARD LAYOUT

DDF0008A

SOT-23 - 1.1 mm max height

PLASTIC SMALL OUTLINE

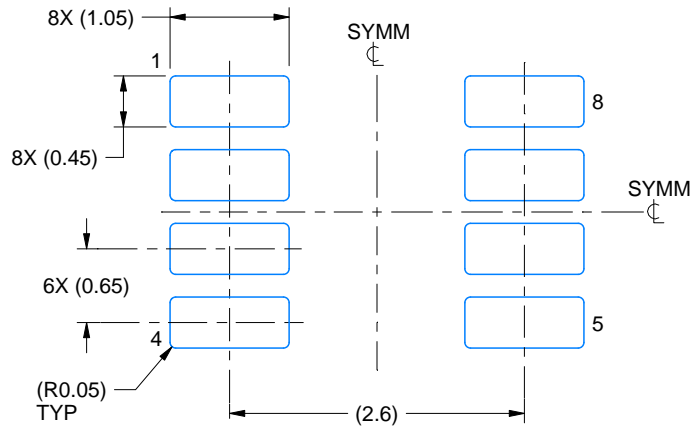

LAND PATTERN EXAMPLE
EXPOSED METAL SHOWN
SCALE:15X

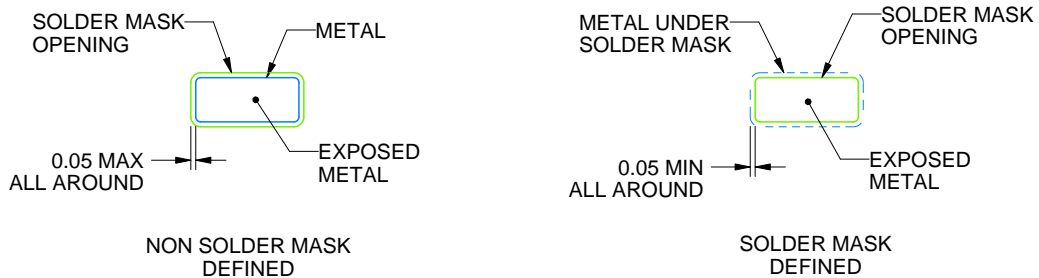

SOLDER MASK DETAILS

4222047/D 04/2024

NOTES: (continued)

- 4. Publication IPC-7351 may have alternate designs.
- 5. Solder mask tolerances between and around signal pads can vary based on board fabrication site.

EXAMPLE STENCIL DESIGN

DDF0008A

SOT-23 - 1.1 mm max height

PLASTIC SMALL OUTLINE



SOLDER PASTE EXAMPLE
BASED ON 0.125 mm THICK STENCIL
SCALE:15X

4222047/D 04/2024

NOTES: (continued)

6. Laser cutting apertures with trapezoidal walls and rounded corners may offer better paste release. IPC-7525 may have alternate design recommendations.
7. Board assembly site may have different recommendations for stencil design.

IMPORTANT NOTICE AND DISCLAIMER

TI PROVIDES TECHNICAL AND RELIABILITY DATA (INCLUDING DATA SHEETS), DESIGN RESOURCES (INCLUDING REFERENCE DESIGNS), APPLICATION OR OTHER DESIGN ADVICE, WEB TOOLS, SAFETY INFORMATION, AND OTHER RESOURCES "AS IS" AND WITH ALL FAULTS, AND DISCLAIMS ALL WARRANTIES, EXPRESS AND IMPLIED, INCLUDING WITHOUT LIMITATION ANY IMPLIED WARRANTIES OF MERCHANTABILITY, FITNESS FOR A PARTICULAR PURPOSE OR NON-INFRINGEMENT OF THIRD PARTY INTELLECTUAL PROPERTY RIGHTS.

These resources are intended for skilled developers designing with TI products. You are solely responsible for (1) selecting the appropriate TI products for your application, (2) designing, validating and testing your application, and (3) ensuring your application meets applicable standards, and any other safety, security, regulatory or other requirements.

These resources are subject to change without notice. TI grants you permission to use these resources only for development of an application that uses the TI products described in the resource. Other reproduction and display of these resources is prohibited. No license is granted to any other TI intellectual property right or to any third party intellectual property right. TI disclaims responsibility for, and you will fully indemnify TI and its representatives against, any claims, damages, costs, losses, and liabilities arising out of your use of these resources.

TI's products are provided subject to [TI's Terms of Sale](#) or other applicable terms available either on [ti.com](https://www.ti.com) or provided in conjunction with such TI products. TI's provision of these resources does not expand or otherwise alter TI's applicable warranties or warranty disclaimers for TI products.

TI objects to and rejects any additional or different terms you may have proposed.

Mailing Address: Texas Instruments, Post Office Box 655303, Dallas, Texas 75265
Copyright © 2024, Texas Instruments Incorporated