

Input and Output Capacitor Considerations in a Synchronous Buck Converter



George Lakkas

Capacitors are an essential component of a synchronous buck converter. There's a variety of capacitor technologies so it's important to know what parameter of the input and output capacitors you need to consider when designing a synchronous buck converter as shown in [Figure 1](#).

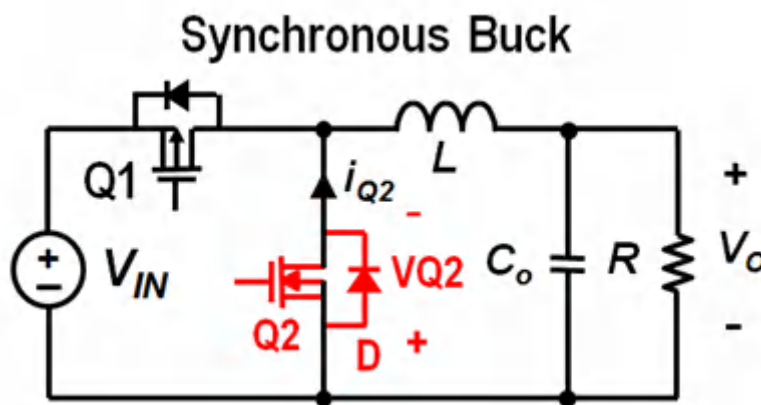

Figure 1. Synchronous Buck DC/DC Converter

Power capacitors selection considerations are shown in the [Table 1](#) below:

Table 1. Buck Converter Performance vs. Capacitor Parameter

Buck Converter Performance Characteristic	Capacitor Parameter To Consider
Power Dissipation	Effective Series Resistance (ESR)
Voltage Ripple Performance	Effective Series Resistance (ESR)
Load Transient (AC) performance	Effective Series Inductance (ESL) Effective Series Resistance (ESR) Capacitance
Cost	Technology and Vendor dependent
Size	Width, Length, Height
Reliability	Capacitor Material

Table 2 below shows the relative capacitor characteristics depending on the technology.

Table 2. Relative Capacitor Characteristics

Capacitor Technology	ESR	Cost	Current Rating
Std Al Electrolytic	high	low	low
OSCON	low	medium	high
POSCAP	low	high	medium
Tantalum	medium	medium	medium
Ceramic	very low	very high	high

Capacitor impedance over frequency is also important as it determines the buck converter switching frequency at which the capacitor acts as a capacitor for energy storage, and not as an inductor. Impedance can be due to the ESR (Effective Series Resistance) and ESL (Effective Series Inductance) of a capacitor and it looks like a U-shaped curve as shown in Figure 2. The Self-Resonant Frequency, also shown in Figure 2, is the frequency after which the capacitor starts to look like an inductor (example shown for the 10uF capacitor). Ideally, we want the buck converter to switch at a switching frequency in the capacitor region.

We can use combinations of capacitors to “flatten” the impedance curve with the objective to push the buck converter switching frequency higher while still operating in the capacitive region. Capacitor impedance varies by technology and switching frequency.

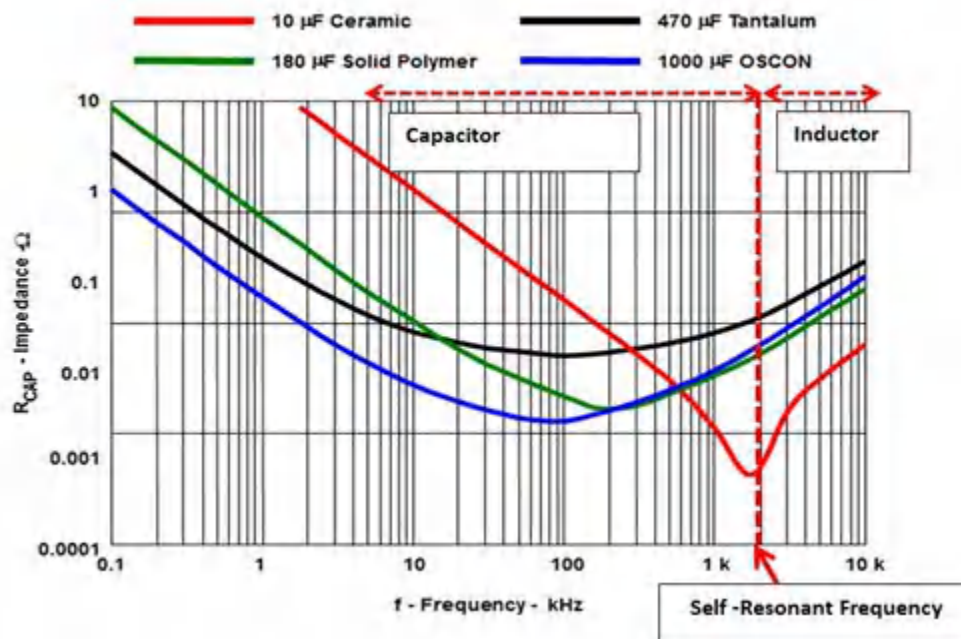

Figure 2. Capacitor Impedance over Switching Frequency

So, how do you choose a capacitor for an input and output filter?

For an input filter you choose a capacitor to handle the input AC current (ripple) and input voltage ripple.

For an output filter you choose a capacitor to handle the load transients and to minimize the output voltage ripple.

The equation in Figure 3 shows the equation to determine the input current RMS (Root-Mean-Squared) current the capacitor can handle. Based on the input voltage, the input current RMS current, and the input voltage peak-to-peak ripple you can choose the capacitor looking at the capacitor datasheets. It is recommended to use a combination of Aluminum Electrolytic (AIEI) and ceramic capacitors. Ceramic capacitors have low ESR and they can reduce the input voltage peak-to-peak ripple, which, in turn, reduces the input ripple current for the input bulk capacitors to handle.

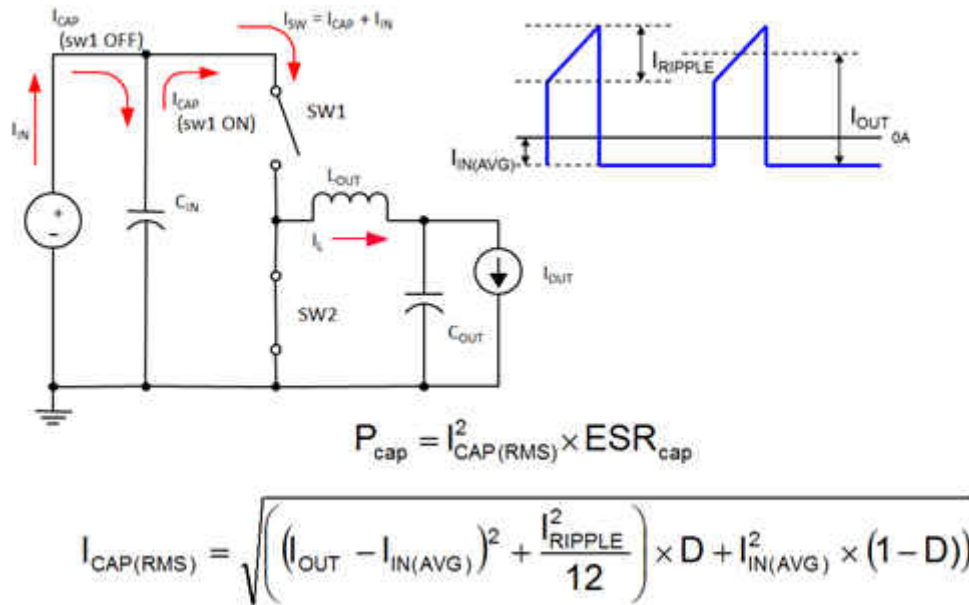

Figure 3. Input Capacitor RMS Current Calculation

When considering output capacitors, Table 3 below shows the selection criteria:

Table 3. Output Capacitor Criteria

Capacitor Parameter	Load Transient Performance	Output Voltage Ripple
Bulk Capacitance (for energy storage and delivery to the load)	Major Effect	Major Effect
ESR	Major Effect	Major Effect
ESL	Major Effect	Minor Effect

Figure 4 below shows how each Output Capacitor Component can affect the buck converter load transient performance.

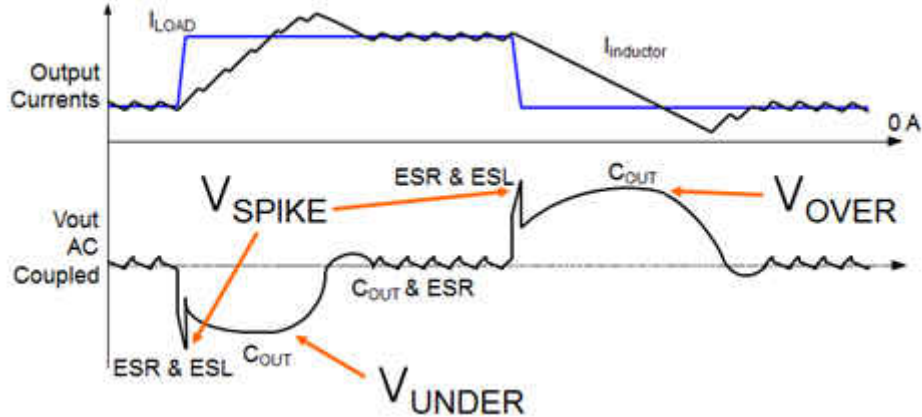

Figure 4. Capacitor Criteria in Load Transient Performance

Capacitor calculations for the output voltage overshoot, undershoot, and peak-to-peak voltage ripple are used to determine the capacitance as shown in Figure 5 and Figure 6 below.

$$C_o > \frac{L \times I_{STEP}^2}{2 \times V_{UNDER} \times D_{max} \times (V_{IN} - V_{OUT})}$$

$$C_o > \frac{L \times I_{STEP}^2}{2 \times V_{OVER} \times V_{OUT}}$$

Figure 5. Determining Output Capacitance for Output Voltage Undershoot and Overshoot

$$V_{RIPPLE} = I_{RIPPLE} \times ESR + \frac{I_{RIPPLE}}{8 \times F_s \times C_o}$$

Figure 6. Determining Output Capacitance for Output Voltage Peak-to-peak Ripple Handling

An example for selecting an output capacitor is shown below:

Output Capacitor Selection Example:

- 2A to 10A load step @ 15A/ms
- Use 2x 1000 mF Aluminum. Elco: 19mW ESR
 - PLOSS = $(3.32/2)^2 \times 19/2 \times 10^{-3} = 0.024W$
- To help reduce spikes, add two 10 mF ceramics (1210), 0.8mW ESR , 1.1nH ESL each
- This selection yields:
 - 1.7mV output voltage undershoot
 - 10.7mV output voltage overshoot
 - 19.9mV voltage spikes
 - 2.8mV of output voltage peak-to-peak ripple

So, when designing a buck converter keep these capacitor selection criteria in mind for a high-performance, stable and reliable design! Consider one of TI's [buck converters](#) and [buck controllers](#) for your next DC/DC power supply design.

IMPORTANT NOTICE AND DISCLAIMER

TI PROVIDES TECHNICAL AND RELIABILITY DATA (INCLUDING DATA SHEETS), DESIGN RESOURCES (INCLUDING REFERENCE DESIGNS), APPLICATION OR OTHER DESIGN ADVICE, WEB TOOLS, SAFETY INFORMATION, AND OTHER RESOURCES "AS IS" AND WITH ALL FAULTS, AND DISCLAIMS ALL WARRANTIES, EXPRESS AND IMPLIED, INCLUDING WITHOUT LIMITATION ANY IMPLIED WARRANTIES OF MERCHANTABILITY, FITNESS FOR A PARTICULAR PURPOSE OR NON-INFRINGEMENT OF THIRD PARTY INTELLECTUAL PROPERTY RIGHTS.

These resources are intended for skilled developers designing with TI products. You are solely responsible for (1) selecting the appropriate TI products for your application, (2) designing, validating and testing your application, and (3) ensuring your application meets applicable standards, and any other safety, security, regulatory or other requirements.

These resources are subject to change without notice. TI grants you permission to use these resources only for development of an application that uses the TI products described in the resource. Other reproduction and display of these resources is prohibited. No license is granted to any other TI intellectual property right or to any third party intellectual property right. TI disclaims responsibility for, and you will fully indemnify TI and its representatives against, any claims, damages, costs, losses, and liabilities arising out of your use of these resources.

TI's products are provided subject to [TI's Terms of Sale](#) or other applicable terms available either on [ti.com](https://www.ti.com) or provided in conjunction with such TI products. TI's provision of these resources does not expand or otherwise alter TI's applicable warranties or warranty disclaimers for TI products.

TI objects to and rejects any additional or different terms you may have proposed.

Mailing Address: Texas Instruments, Post Office Box 655303, Dallas, Texas 75265
Copyright © 2023, Texas Instruments Incorporated