

Circuit for driving a switched-capacitor SAR ADC with an instrumentation amplifier

Art Kay, Bryan McKay

Input	ADC Input	Digital Output ADS8860
–5mV	Out = 0.2V	0A3D _H or 2621 ₁₀
15mV	Out = 4.8V	F5C3 _H or 62915 ₁₀

Power Supplies					
AVDD	DVDD	V _{ref_INA}	V _{ref}	V _{CC}	V _{EE}
5.0V	3.0V	3.277V	5.0V	+15V	–15V

Design Description

Instrumentation amplifiers are a common way of translating low level sensor outputs to high level signals to drive an ADC. Typically, instrumentation amplifiers are optimized for low noise, low offset, and low drift. Unfortunately, the bandwidth of many instrumentation amplifiers may not be sufficient to achieve good settling to ADC charge kickback at maximum sampling rates. This document shows how sampling rate can be adjusted to achieve good settling. Furthermore, many instrumentation amplifiers are optimized for high-voltage supplies and it may be required to interface the high-voltage output (that is, $\pm 15\text{V}$) to a lower voltage ADC (for example, 5V). This design shows how to use Schottky diodes and a series resistor to protect the ADC input from an overvoltage condition. Note that the following circuit shows a bridge sensor, but this method could be used for a wide range of different sensors. A modified version of this circuit, [Driving a Switched-Capacitor SAR With a Buffered Instrumentation Amplifier](#) shows how a wide bandwidth buffer can be used to achieve higher sampling rate.

This circuit implementation is applicable to all [Bridge Transducers in PLC's](#) and [Analog Input Modules](#) that require Precision Signal-Processing and Data-Conversion.

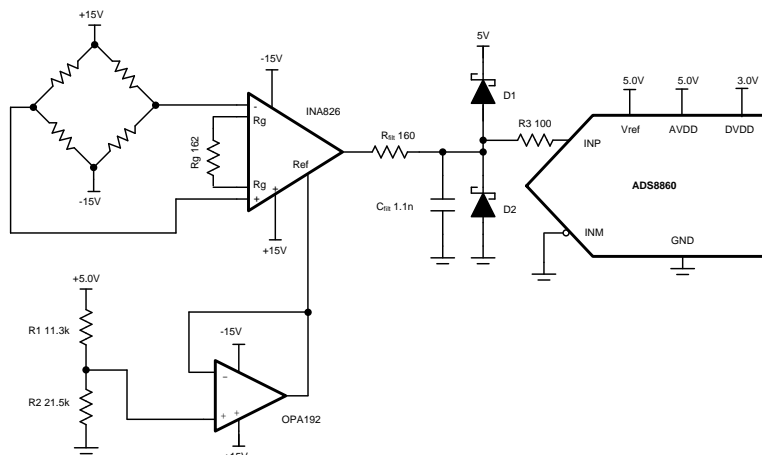

Copyright © 2017, Texas Instruments Incorporated

Specifications

Specification	Calculated	Simulated
Sampling rate	200ksps	200ksps, settling to $-6\mu\text{V}$
Offset (ADC Input)	$40\mu\text{V} \cdot 306.7 = 12.27\text{mV}$	16mV
Offset Drift	$(0.4\mu\text{V}/^\circ\text{C}) \cdot 306.7 = 123\mu\text{V}/^\circ\text{C}$	NA
Noise	978 μV	874 μV

Design Notes

1. Select the gain to achieve an input swing that matches the input range of the ADC. Use the instrumentation amplifier reference pin to shift the signal offset to match the input range. This is covered in the *component selection* section.
2. The input Schottky diode configuration is used to prevent driving the input voltage outside of the absolute maximum specifications. The BAT54S Schottky is a good option for design as this device integrates both diodes into one package and the diodes are low leakage and have a low forward voltage. This is covered in the *component selection* section.
3. The buffer amplifier following the voltage divider is required for driving the reference input of most instrumentation amplifiers. Choose precision resistors and a precision low-offset amplifier as the buffer. Refer to [Selecting the right op amp](#) for more details on this subject.
4. Check the common-mode range of the amplifier using the [Common-Mode Input Range Calculator for Instrumentation Amplifiers](#) software tool.
5. Select C0G capacitors for C_{CM1} , C_{CM2} , C_{DIF} , and C_{filt} to minimize distortion.
6. Use 0.1% 20ppm/ $^\circ\text{C}$ film resistors or better for the gain set resistor R_g . The error and drift of this resistor will directly translate into gain error and gain drift.
7. The [TI Precision Labs – ADCs](#) training video series covers methods for selecting the charge bucket circuit R_{filt} and C_{filt} . Although this method was designed for op amps, it can be modified for instrumentation amplifiers. Refer to [Introduction to SAR ADC Front-End Component Selection](#) for details on this subject.

Component Selection

- Find the gain set resistor for the instrumentation amplifier to set the output swing to 0.2V to 4.8V.

$$\text{Gain} = \frac{V_{\text{out_max}} - V_{\text{out_min}}}{V_{\text{in_max}} - V_{\text{in_min}}} = \frac{4.9\text{V} - 0.2\text{V}}{5\text{mV} - (-10\text{mV})} = 306.7$$

$$\text{Gain} = 1 + \frac{49.4\text{k}\Omega}{R_g}$$

$$R_g = \frac{49.4\text{k}\Omega}{\text{Gain} - 1.0} = \frac{49.4\text{k}\Omega}{(306.7) - 1.0} = 151.6\Omega \text{ or } 162\Omega \text{ for standard 0.1\% resistor}$$

- Find the INA826 reference voltage (V_{ref}) to shift the output swing to the proper voltage level.

$$V_{\text{out}} = \text{Gain} \cdot V_{\text{in}} + V_{\text{ref_INA}}$$

$$V_{\text{ref_INA}} = V_{\text{out}} - \text{Gain} \cdot V_{\text{in}} = 4.8\text{V} - \left(1 + \frac{49.4\text{k}\Omega}{162\Omega}\right)(5\text{mV}) = 3.27\text{V}$$

- Select standard value resistors to set the INA826 reference voltage ($V_{\text{ref}} = 3.27\text{V}$). *Use Analog Engineer's Calculator* ("Passive\Find Voltage Divider" section) to find standard values for the voltage divider.

$$V_{\text{ref_INA}} = \frac{R_2}{R_1 + R_2} V_{\text{in_div}} = \frac{21.5\text{k}\Omega}{11.3\text{k}\Omega + 21.5\text{k}\Omega} (5\text{V}) = 3.277\text{V}$$

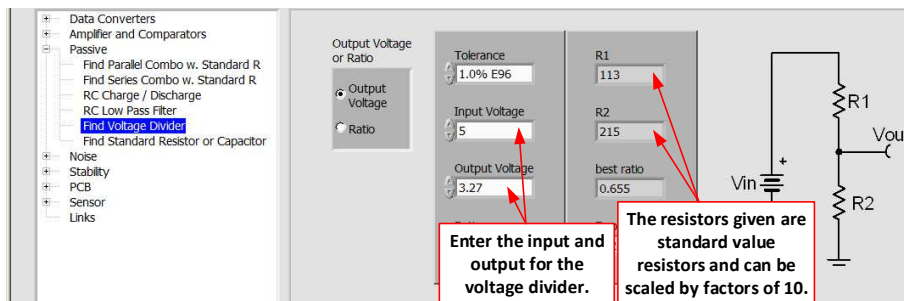

- Use the *Common-Mode Input Range Calculator for Instrumentation Amplifiers* to determine if the INA826 is violating the common-mode range.

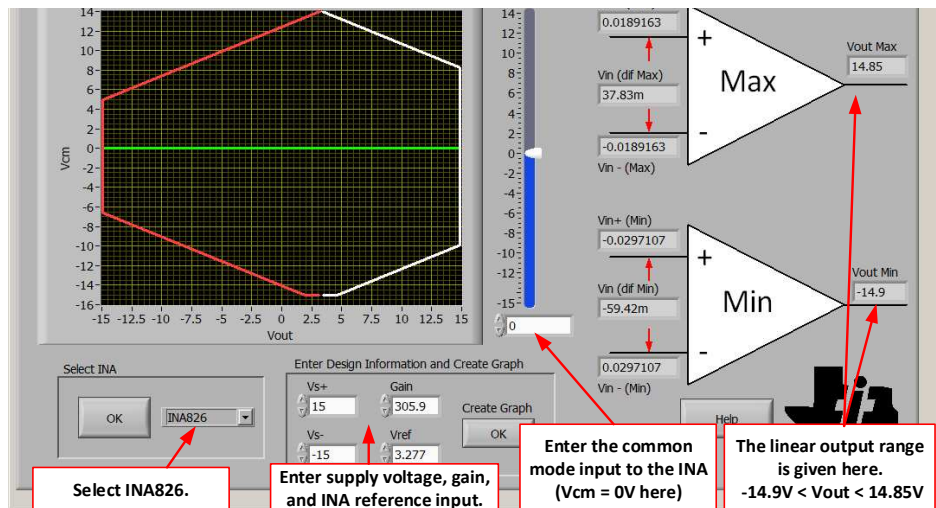

DC Transfer Characteristics

The following graph shows a linear output response for inputs from -5mV to $+15\text{mV}$. Refer to [Determining a SAR ADC's Linear Range when using Instrumentation Amplifiers](#) for detailed theory on this subject. Note that the output range is intentionally limited to -0.12V to 5.12V using Schottky diodes to protect the ADS8860. Note that Schottky diodes are used because the low forward voltage drop (typically less than 0.3V) keeps the output limit very near the ADC supply voltages. The absolute maximum rating for the ADS8860 is $-0.3\text{V} < V_{in} < \text{REF} + 0.3\text{V}$.

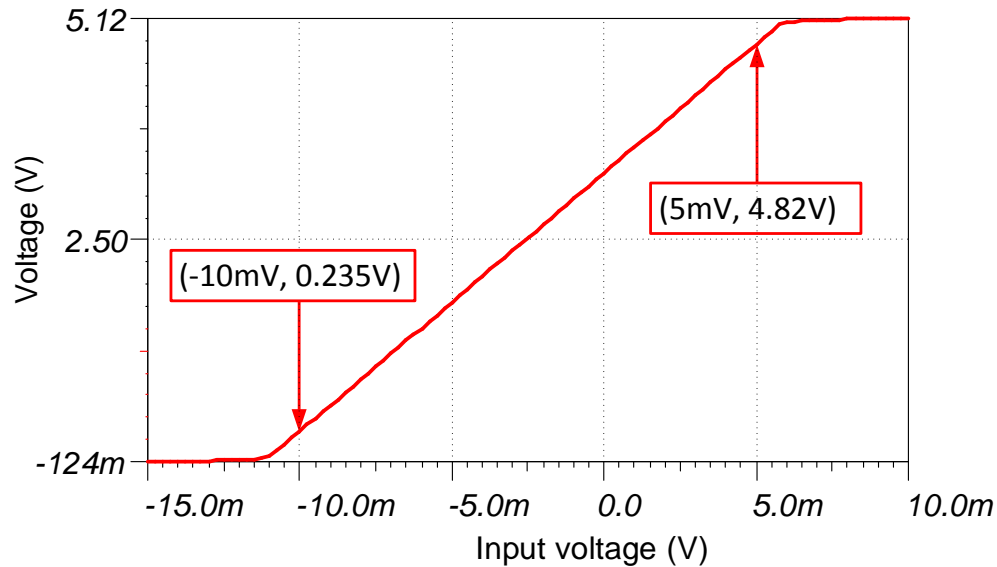

AC Transfer Characteristics

The bandwidth is simulated to be 20.1kHz , and the gain is 49.7dB which is a linear gain of 305.8 . See the video series on [Op Amps: Bandwidth 1](#) for more details on this subject.

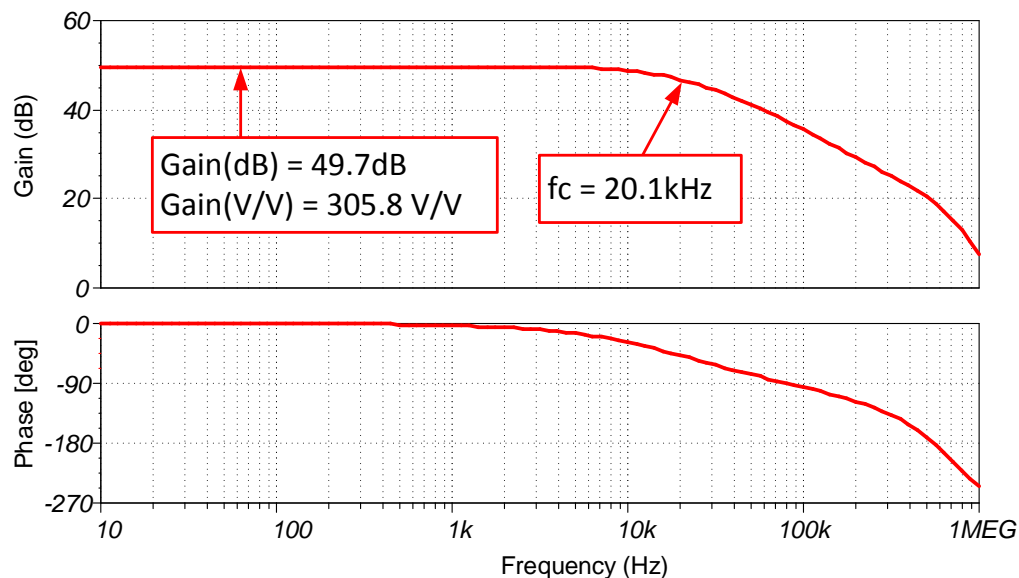

Transient ADC Input Settling Simulation

The following simulation shows settling to a +15mV dc input signal. This type of simulation shows that the sample and hold kickback circuit is properly selected. Refer to [Introduction to SAR ADC Front-End Component Selection](#) for detailed theory on this subject

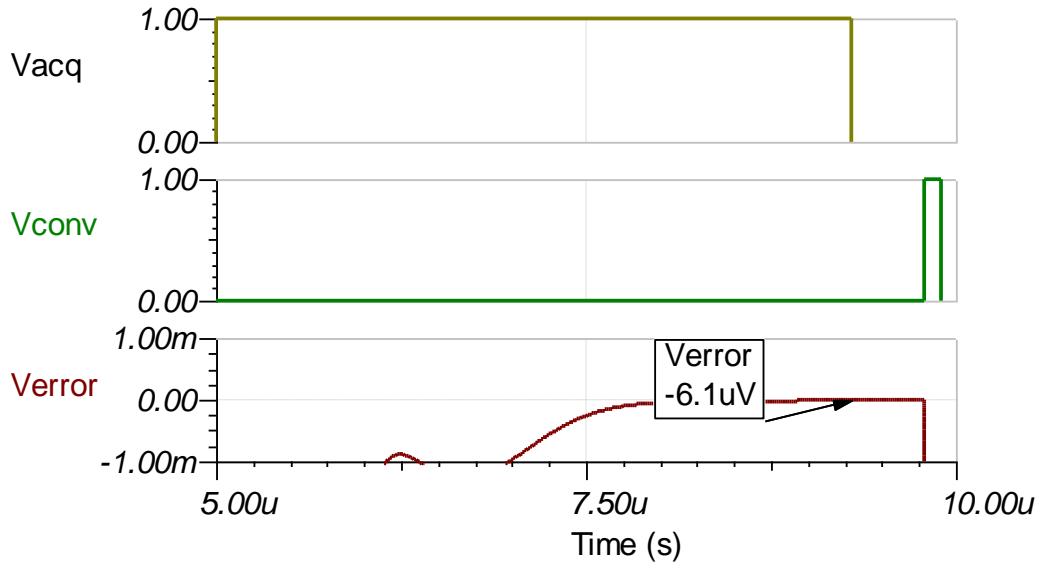

Noise Simulation

The following simplified noise calculation is provided for a rough estimate. We neglect noise from the OPA192 as the instrumentation amplifier is in high gain, so its noise is dominant.

$$E_n = \text{Gain} \cdot \sqrt{e_{NI}^2 + \left(\frac{e_{NO}}{\text{Gain}}\right)^2} \cdot \sqrt{K_n \cdot f_c}$$

$$E_n = (305.8) \cdot \sqrt{(18\text{nV} / \sqrt{\text{Hz}})^2 + \left(\frac{110\text{nV} / \sqrt{\text{Hz}}}{305.8}\right)^2} \cdot \sqrt{1.57 \cdot (20.1\text{kHz})} = 978\mu\text{V} / \sqrt{\text{Hz}}$$

Note that calculated and simulated match well. Refer to [TI Precision Labs - Op Amps: Noise 4](#) for detailed theory on amplifier noise calculations, and [Calculating the Total Noise for ADC Systems](#) for data converter noise.

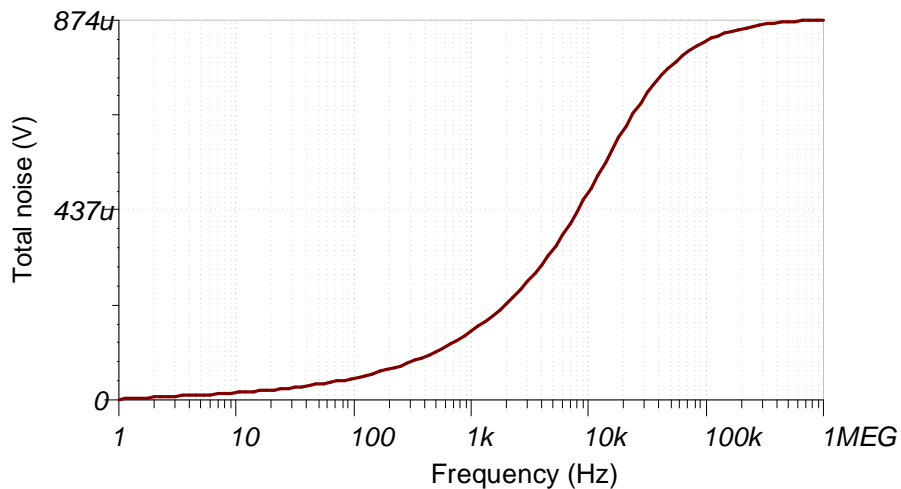

Optional Input Filter

The following figure shows a commonly used instrumentation amplifier input filter. The differential noise is filtered with C_{dif} , and the common-mode noise is filtered with C_{cm1} and C_{cm2} . Note that it is recommended that $C_{dif} \geq 10C_{cm}$. This prevents conversion of common-mode noise to differential noise due to component tolerances. The following filter was designed for a differential cutoff frequency of 15kHz.

Let $C_{dif} = 1nF$ and $f_{dif} = 15kHz$

$$R_{in} < \frac{1}{4 \cdot \pi \cdot f_{dif} \cdot C_{dif}} = \frac{1}{4 \cdot \pi \cdot (15kHz) \cdot (1nF)} = 5.305k\Omega \text{ or } 5.23k\Omega \text{ for } 1\% \text{ standard value}$$

$$C_{cm} = \frac{1}{10} \cdot C_{dif} = 100pF$$

$$f_{cm} = \frac{1}{2 \cdot \pi \cdot R_{in} \cdot C_{cm}} = \frac{1}{2 \cdot \pi \cdot (5.23k\Omega) \cdot (100pF)} = 304kHz$$

$$f_{dif} = \frac{1}{4 \cdot \pi \cdot R_{in} \cdot \left(C_{dif} + \frac{1}{2} C_{cm} \right)} = \frac{1}{4 \cdot \pi \cdot (5.23k\Omega) \cdot \left(1nF + \frac{1}{2} \cdot 100pF \right)} = 14.5kHz$$

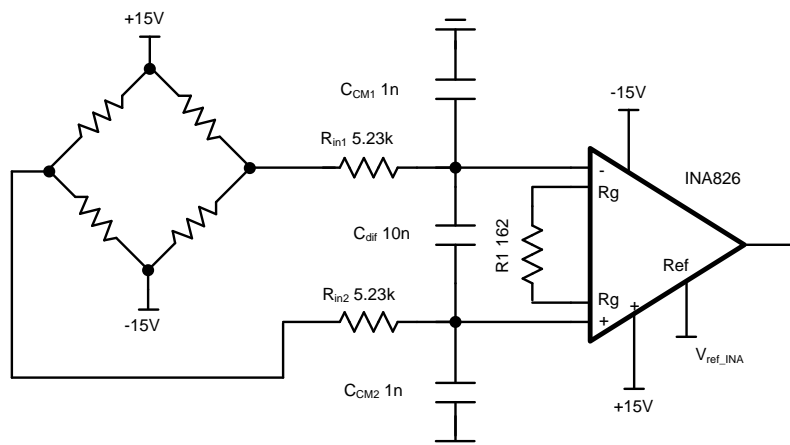

Copyright © 2017, Texas Instruments Incorporated

Design Featured Devices

Device	Key Features	Link	Similar Devices
ADS8860	16-bit resolution, SPI, 1Msps sample rate, single-ended input, Vref input range 2.5 V to 5.0 V.	www.ti.com/product/ADS8860	www.ti.com/adcs
OPA192	Bandwidth 10MHz, Rail-to-Rail input and output, low noise 5.5nV/rHz, low offset $\pm 5\mu\text{V}$, low offset drift $\pm 0.2\mu\text{V}/^\circ\text{C}$. (Typical values)	www.ti.com/product/OPA192	www.ti.com/opamp
INA826	Bandwidth 1MHz (G = 1), low noise 18nV/rHz, low offset $\pm 40\mu\text{V}$, low offset drift $\pm 0.4\mu\text{V}/^\circ\text{C}$, low gain drift 0.1ppm/ $^\circ\text{C}$. (Typical values)	www.ti.com/product/INA826	www.ti.com/inas

Design References

See [Analog Engineer's Circuit Cookbooks](#) for TI's comprehensive circuit library.

Link to Key Files

Source files for this design - <http://www.ti.com/lit/zip/sbac184>.

Revision History

Revision	Date	Change
A	March 2019	Downstyle the title and changed title role to 'Data Converters'. Added link to circuit cookbook landing page.

IMPORTANT NOTICE AND DISCLAIMER

TI PROVIDES TECHNICAL AND RELIABILITY DATA (INCLUDING DATA SHEETS), DESIGN RESOURCES (INCLUDING REFERENCE DESIGNS), APPLICATION OR OTHER DESIGN ADVICE, WEB TOOLS, SAFETY INFORMATION, AND OTHER RESOURCES "AS IS" AND WITH ALL FAULTS, AND DISCLAIMS ALL WARRANTIES, EXPRESS AND IMPLIED, INCLUDING WITHOUT LIMITATION ANY IMPLIED WARRANTIES OF MERCHANTABILITY, FITNESS FOR A PARTICULAR PURPOSE OR NON-INFRINGEMENT OF THIRD PARTY INTELLECTUAL PROPERTY RIGHTS.

These resources are intended for skilled developers designing with TI products. You are solely responsible for (1) selecting the appropriate TI products for your application, (2) designing, validating and testing your application, and (3) ensuring your application meets applicable standards, and any other safety, security, regulatory or other requirements.

These resources are subject to change without notice. TI grants you permission to use these resources only for development of an application that uses the TI products described in the resource. Other reproduction and display of these resources is prohibited. No license is granted to any other TI intellectual property right or to any third party intellectual property right. TI disclaims responsibility for, and you will fully indemnify TI and its representatives against, any claims, damages, costs, losses, and liabilities arising out of your use of these resources.

TI's products are provided subject to [TI's Terms of Sale](#) or other applicable terms available either on ti.com or provided in conjunction with such TI products. TI's provision of these resources does not expand or otherwise alter TI's applicable warranties or warranty disclaimers for TI products.

TI objects to and rejects any additional or different terms you may have proposed.

Mailing Address: Texas Instruments, Post Office Box 655303, Dallas, Texas 75265
Copyright © 2021, Texas Instruments Incorporated