

TLV320ADCx120 and PCMx120-Q1 Programmable Biquad Filter Configuration and Applications



Muthuraj Pillai, Diljith Thodi

ABSTRACT

The TLV320ADCx120 (TLV320ADC3120, TLV320ADC5120, and TLV320ADC6120) and PCMx120-Q1 (PCM3120-Q1, PCM5120-Q1, PCM6120-Q1) device family is a dual-channel, high-performance, analog-to-digital converter (ADC) for audio applications. This family of devices has an extensive set of features that includes the following:

- Multichannel, multi-bit, high-performance delta-sigma ADC
- Configurable single-ended or differential audio inputs
- A low-noise programmable microphone bias voltage output
- An integrated low-jitter phase-locked loop (PLL)
- Linear phase or Low-latency decimation filters with sample rates up to 768 kHz
- Programmable phase and gain calibration with fine resolution for each channel
- Programmable channel gain
- Digital volume control
- Digital channel mixer
- A programmable high-pass filter (HPF)
- A programmable Infinite Impulse Response Bi-quad filters
- Automatic Gain Controller (AGC)
- Dynamic Range Enhancer (DRE) support in TLV320ADC5120, TLV320ADC6120, PCM5120-Q1 and PCM6120-Q1
- Pulse density modulation (PDM) digital microphone interface with high-performance decimation filters

This application note describes how to configure the programmable Infinite Impulse Response (IIR) Digital Biquad Filters of the TLV320ADCx120 and PCMx120-Q1 devices.

Table of Contents

1 Introduction	3
2 Infinite Impulse Response Filters	4
2.1 Digital Biquad Filter.....	4
3 TLV320ADCx120 and PCMx120-Q1 Digital Biquad Filters	5
3.1 Filter Design Using PurePath™ Console.....	5
3.2 How to Generate N_0 , N_1 , N_2 , D_1 , and D_2 Coefficients with a Digital Filter Design Package.....	7
3.3 Avoid Overflow Conditions.....	7
3.4 Digital Biquad Filter Allocation to Output Channel.....	8
3.5 Programmable Coefficient Registers for Digital Biquad Filters 1–6.....	10
3.6 Programmable Coefficient Registers for Digital Biquad Filters 7–12.....	13
4 How to Program the Digital Biquad Filters on the TLV320ADCx120 and PCMx120-Q1	16
5 Typical Audio Applications for Biquad Filtering	16
5.1 Parametric Equalizers.....	16
6 Crossover Networks	16
7 Voice Boost	16
8 Bass Boost	17
9 Removing 50 Hz–60 Hz Hum With Notch Filters	17
A Digital Filter Design Techniques	18
A.A Analog Filters.....	18

B Related Documentation	20
B Revision History	20

List of Figures

Figure 1-1. TLV320ADCx120 and PCMx120-Q1 Channel Signal Chain Processing Flow Chart.....	3
Figure 2-1. Direct Form II Biquad Filter.....	4
Figure 3-1. Q-31 Format Representation.....	5
Figure 3-2. PurePath™ Console Programmable Biquad Filter Example.....	6
Figure 3-3. PurePath™ Console Programmable Biquad Filter Example Showing the Computed Coefficients in Normalized Floating Point Format.....	7
Figure 3-4. TLV320ADC3120 and PCM3120-Q1 DSP_CFG1 Register.....	8
Figure 3-5. TLV320ADC5120, TLV320ADC6120, PCM 5120-Q1 and PCM6120-Q1 DSP_CFG1 Register.....	8

List of Tables

Table 3-1. PurePath™ Console Digital Biquad Filter Options.....	5
Table 3-2. Biquad Filter Allocation to the Record Output Channel.....	8
Table 3-3. Biquad Filter Coefficients Register Mapping.....	8
Table 3-4. DSP_CFG1 Register Field Descriptions.....	9
Table 3-5. Page 0x02 Programmable Coefficient Registers for Biquad Filters 1–6.....	10
Table 3-6. Page 0x03 Programmable Coefficient Registers for Biquad Filters 7–12.....	13
Table A-1. PurePath™ Console Filter Transfer Function.....	18

Trademarks

PurePath™ and Burr-Brown™ are trademarks of Texas Instruments.
 MATLAB® is a registered trademark of The Mathworks Inc.
 All trademarks are the property of their respective owners.

1 Introduction

Each channel of the TLV320ADCx120 and PCMx120-Q1 devices follows the signal chain shown in [Figure 1-1](#). In this signal chain, each channel supports an analog differential or single-ended signal or a digital pulse density modulation (PDM) digital microphone. In TLV320ADCx120 and PCMx120-Q1 device families, the analog input signal is amplified by a Programmable Gain Amplifier (PGA) and then converted by a high-performance ADC into a digital signal. The PGA gains the input signal to match the full scale of the ADC. The digital signal has a programmable phase calibration to adjust the phase delay of each channel in steps of one modulator clock cycle. This allows the system to match the phase across different channels. The phase-calibrated digital signal is then decimated through a set of linear phase filters or low-latency filters. DC offset is removed from the decimated signal through a Digital High-Pass Filter (HPF) with three preset cutoff frequencies or a fully programmable cutoff frequency. Note that DC shifts are caused by mismatches in common-mode voltages. The output of the HPF is gain calibrated with 0.1-dB steps and summed with other channels. The gain calibration matches the gain across different channels, particularly if the channels have microphones with varying gain values. The output is then filtered by the Digital Biquad Filters and gained by the volume control.

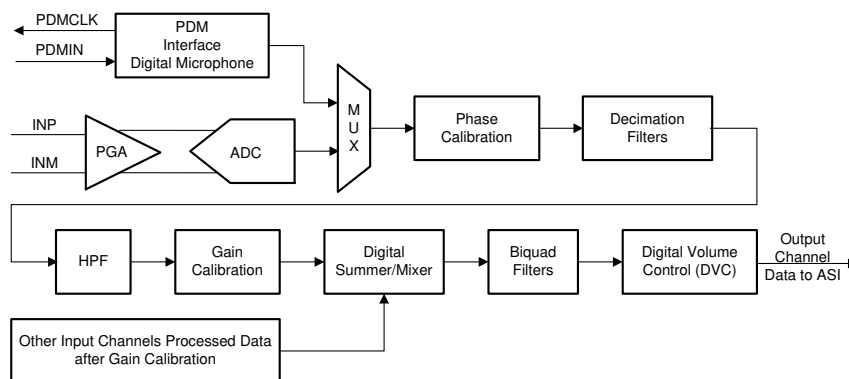

Figure 1-1. TLV320ADCx120 and PCMx120-Q1 Channel Signal Chain Processing Flow Chart

This application note concentrates on how to configure the Digital Biquad Filters. The Digital Biquad Filters are digitally implemented as a set of IIR filters.

2 Infinite Impulse Response Filters

Equation 1 specifies the transfer function of infinite impulse response filters (IIR).

$$H(z) = \frac{b_0 + b_1 z^{-1} + b_2 z^{-2} + \dots + b_M z^{-M}}{1 + a_1 z^{-1} + a_2 z^{-2} + \dots + a_N z^{-N}} \quad (1)$$

When the coefficients of this transfer function are quantized for fixed point implementations, the resulting errors due to quantization and the recursive nature of the filter can significantly alter the desired filter characteristics and lead to instability. Partitioning this transfer function into a set of cascaded lower-order filters reduces the sensitivity to coefficient quantization. Cascaded Biquad IIR filter implementations have been proven to be effective in minimizing these effects.

2.1 Digital Biquad Filter

A Digital Biquad Filter is a second-order IIR filter with two poles and two zeros. “Biquad” is an abbreviation of “biquadratic.” Thus, a Digital Biquad Filter is an IIR filter whose transfer function is the ratio of two quadratic functions given by Equation 2 and the corresponding direct form II block diagram shown in Figure 2-1. In this equation, the coefficients are normalized so that $a_0 = 1$ through the division of all the coefficients by a_0 .

$$H(z) = \frac{b_0 + b_1 z^{-1} + b_2 z^{-2}}{1 + a_1 z^{-1} + a_2 z^{-2}} \quad (2)$$

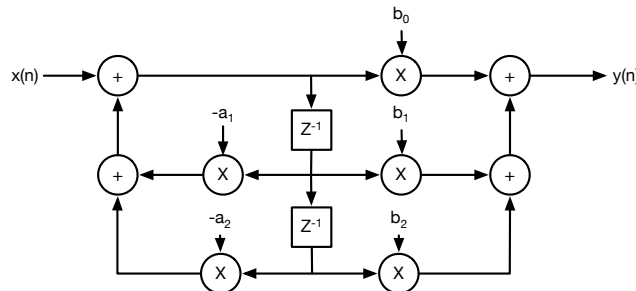

Figure 2-1. Direct Form II Biquad Filter

3 TLV320ADCx120 and PCMx120-Q1 Digital Biquad Filters

The TLV320ADCx120 and PCMx120-Q1 devices support up to three programmable Digital Biquad Filters in the signal chain of each channel shown in [Figure 1-1](#). The programmable Biquad Filters lie between the Digital Summer and the Digital Volume Control blocks. The Biquad Filters allow for custom low-pass, high-pass, or any other desired frequency shaping of the signal. By default, the frequency response for each Biquad Filter is an all-pass filter, meaning a frequency response with flat gain of 0 dB. A host can override the frequency response of these Biquad filters by changing the programmable coefficients of each Biquad Filter. To change the coefficients, the host must write the Biquad Filters coefficients before powering any ADC channels.

[Equation 3](#) shows the quantized 32-bit transfer function implemented in the TLV320ADCx120 and PCMx120-Q1. The coefficients of these biquad filters [N₀, N₁, N₂, D₁, and D₂] are each 32-bits wide, in 2s-complement format, and occupy four consecutive 8-bit registers in the TLV320ADCx120 and PCMx120-Q1 register space. With the Q-point in the 31st bit location (Q31), the filter coefficients are in 1.31 format with a range from -1 (0x80000000) to 0.999999995 (0x7FFFFFFF). In this notation, the decimal point is assumed to be between bit 30 and bit 31. Bit 31 contains the sign bit, while bits 30–0 contain the fractional bits as shown in [Figure 3-1](#). With this notation, all coefficients are normalized to less than 1. To convert a floating point number less than one to Q31 format, multiply the floating point number by 2³¹ and truncate to the nearest integer. With this notation, the number 1, corresponding to a₀ in the denominator, becomes 2⁻³¹ (0x7FFFFFFF). Note that the coefficients N₁ and D₁ are multiplied by two. Thus, when using a digital filter design package to calculate these coefficients, divide by 2 the N₁ and D₁ before writing these coefficient registers. Also, note that coefficients D₁ and D₂ have a negative sign. So, multiply by -1 before writing D₁ and D₂ to the coefficient registers when using a digital filter design package.

$$H(z) = \frac{N_0 + 2N_1 z^{-1} + N_2 z^{-2}}{2^{31} - 2D_1 z^{-1} - D_2 z^{-2}} \tag{3}$$

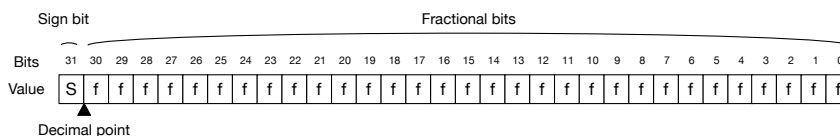

Figure 3-1. Q-31 Format Representation

3.1 Filter Design Using PurePath™ Console

To facilitate the use of the Digital Biquad Filters, the PurePath™ Console includes a graphical filter design section that plots the magnitude, phase, and group delay versus frequency. This filter design also generates the coefficients through several different filter design techniques filters. [Equation 3](#) shows the available filter design options with a short description of the filter type. In [Table 3-1](#), the cutoff frequency refers to the frequency when the response changes by 3 dB from the pass band.

Table 3-1. PurePath™ Console Digital Biquad Filter Options

FILTER TYPE	DESCRIPTION
Band Pass	Band-pass filter at the specified center frequency and pass-band width (filter bandwidth)
Bass Shelf	Specified gain applied at the low frequency up to the specified cutoff frequency
Equalizer (Bandwidth)	Band-pass filters at the specified center frequency and pass-band width, with the specified gain
Equalizer (Q Factor)	Band-pass filter at the specified center frequency and quality factor, with the specified gain. The quality factor is the center frequency divided by the pass-band width.
Gain	All pass filter at the specified gain
High-Pass Butterworth 1	First-order high-pass filter with specified gain, specified cutoff frequency, maximally flat pass band and stop-band response. Stop-band frequency response has a -10 dB / decade slope.
High-Pass Butterworth 2	Second-order high-pass filter with specified gain, specified cutoff frequency, maximally flat pass band and stop-band response. Stop-band frequency response has a -20 dB / decade.
High-Pass Bessel 2	Second-order high-pass filter with specified gain, specified cutoff frequency, maximally flat phase and constant group delay across pass band.

Table 3-1. PurePath™ Console Digital Biquad Filter Options (continued)

FILTER TYPE	DESCRIPTION
High-Pass Linkwitz Riley 2	Second-order high-pass filter composed of a Butterworth filter with –3 dB at the cutoff frequency. When cascading a low-pass and high-pass Linkwitz Riley filters, the overall gain at the crossover frequency is 0 dB.
High-Pass Variable Q 2	Second-order high-pass filter at the specified center frequency, gain, and quality factor. The quality factor is the center frequency divided by the pass-band width.
High-Pass Chebyshev	High-pass filter with equiripple in the pass band with maximally flat response in stop band
Low-Pass Butterworth 1	First-order low-pass filter with specified gain, specified cutoff frequency, maximally flat pass band and stop-band response. Stop-band frequency response has a –10 dB / decade slope.
Low-Pass Butterworth 2	Second-order low-pass filter with specified gain, specified cutoff frequency, maximally flat pass band and stop-band response. Stop-band frequency response has a –20 dB / decade.
Low-Pass Bessel 2	Second-order low-pass filter with specified gain, specified cutoff frequency, maximally flat group delay across pass band
Low-Pass Linkwitz Riley 2	Second-order low-pass filter composed of a Butterworth filter with –3 dB at the cutoff frequency. When cascading a low-pass and high-pass Linkwitz Riley filters, the overall gain at the crossover frequency is 0 dB.
Low-Pass Variable Q 2	Second-order low-pass filter at the specified center frequency, gain, and quality factor. The quality factor is the center frequency divided by the pass-band width.
Low-Pass Chebyshev	Low-pass filter with equiripple in the pass band with maximally flat response in stop band
Notch	Band stop filter at the specified center frequency and stop-band width (filter bandwidth)
Phase Shift	All pass filter with 180 degree phase shift at the specified center frequency through the width given by the bandwidth
Treble Shelf	Specified gain applied at the high frequencies past the specified cutoff frequency

3.1.1 Example Generating Programmable Biquad Coefficients Using PurePath™ Console

Figure 3-2 shows how to create a set of filters for 5-dB boost at 500 Hz with bandwidth of 400 Hz, cut –5 dB at 2 kHz with 3-kHz bandwidth, and a Notch filter at 60 Hz with 50-Hz bandwidth for channel 1. Note that each biquad filter is color-coded. The cyan color refers to BQ1 500-Hz equalizer, light gray to BQ5 2 kHz, and brown to BQ9 Notch filter at 60 Hz. The overall response of all three filters is plotted in red. Note that cutoff or center frequencies are marked on the graph to allow you to drag and move the center frequencies of the filters. The graphical plots allows users to zoom in and out of the frequency response plot and choose logarithmic or linear frequency axis, plot gain, phase, group delay, or impulse response.



Figure 3-2. PurePath™ Console Programmable Biquad Filter Example

Clicking on the swivel arrow at each biquad shows the normalized floating point coefficients for N_0 , N_1 , N_2 , D_1 , and D_2 of Equation 3, as shown in Figure 3-3. Note the PurePath Console has computed the floating point coefficients b_0 , b_1 , b_2 , a_1 , and a_2 of Equation 2 and converted into the necessary values for N_0 , N_1 , N_2 , D_1 , and D_2 . Clicking the **Apply** button transmits the coefficients through I2C to the TLV320ADCx120 and PCMx120-Q1 devices on the EVM.

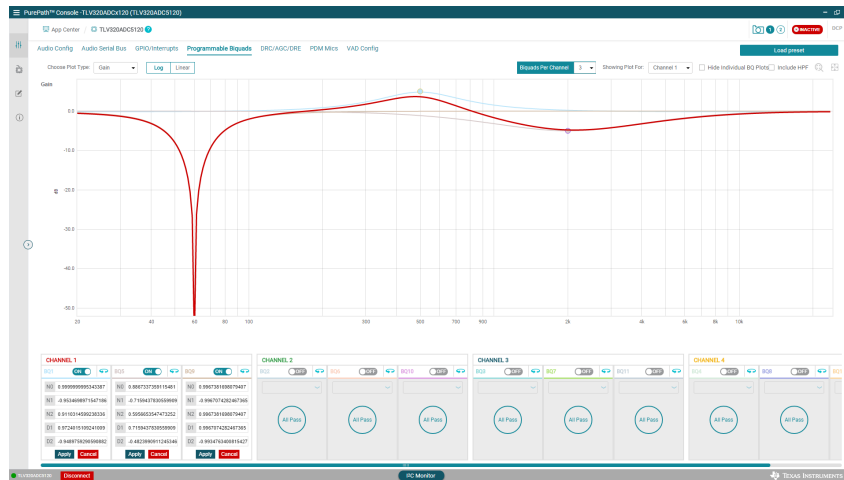

Figure 3-3. PurePath™ Console Programmable Biquad Filter Example Showing the Computed Coefficients in Normalized Floating Point Format

3.2 How to Generate N_0 , N_1 , N_2 , D_1 , and D_2 Coefficients with a Digital Filter Design Package

When using a Digital Filter Design Package, such as MATLAB®, to generate an IIR biquad coefficients follow these steps:

1. Compute the coefficients $[b_0, b_1, b_2, a_0, a_1, a_2]$ with a filter design function, such as the MATLAB butter function to design a Butterworth filter with cutoff at 1 kHz of a system running at 48 kHz. Note that MATLAB coefficients are normalized with $a_0 = 1$.

```
[b, a] = butter( 2, 1000 / (48000/2) )
```

2. Convert these coefficients to $[N_0, N_1, N_2, D_1, D_2]$ by dividing:
 - $N_0 = b_0$
 - $N_1 = b_1 \div 2$
 - $N_2 = b_2$
 - $D_1 = -a_1 \div 2$
 - $D_2 = -a_2$

3. Convert the coefficients to Q31 by multiplying by 2^{31} .

4. Round to nearest integer and convert to a 32-bit two's complement hexadecimal format:
 - For positive integers, convert to hexadecimal format.
 - For negative integers, take the absolute value of the coefficient, convert it to binary, negate it, add one, and convert to hex.

3.3 Avoid Overflow Conditions

When cascading several biquad filters that gain the signal, ensure the overall response of the system does not cause the system to overflow. The biquads are computed in 32-bit fixed point arithmetic. If the overall response of the system in conjunction with the input signal is too large, undesired results can result due to arithmetic saturation. If saturation or overflow occurs, scale the input signal or scale down the coefficients of one or more biquads to keep the overall response of the system from saturating or overflowing.

Note that the overall response of the system is dependent on all the enabled components of the signal chain. The Digital High-Pass filter changes the frequency response at the low frequencies in conjunction with the Digital Biquad Filter response since both of these filters are cascaded together.

3.4 Digital Biquad Filter Allocation to Output Channel

Table 3-2 shows the assignment of these biquad filters to a specific output channel based on the BIQUAD_CFG[1:0] register setting of the DSP_CFG1 register. Setting BIQUAD_CFG[1:0] to 2'b00 disables the Digital Biquad Filters for all channels. Select this setting when no additional filtering is needed for the system application. Table 3-2 also shows the mapping of the biquad filter coefficients in the TLV320ADCx120 and PCMx120-Q1 register space.

Table 3-2. Biquad Filter Allocation to the Record Output Channel

PROGRAMMABLE BIQUAD FILTER	RECORD OUTPUT CHANNEL ALLOCATION USING DSP_CFG1 REGISTER SETTING		
	BIQUAD_CFG[1:0] = 2'b01 (1 BIQUAD PER CHANNEL)	BIQUAD_CFG[1:0] = 2'b10 (DEFAULT) (2 BIQUADS PER CHANNEL)	BIQUAD_CFG[1:0] = 2'b11 (3 BIQUADS PER CHANNEL)
	SUPPORTS ALL 4 CHANNELS	SUPPORTS ALL 4 CHANNELS	SUPPORTS ALL 4 CHANNELS
Biquad filter 1	Allocated to output channel 1	Allocated to output channel 1	Allocated to output channel 1
Biquad filter 2	Allocated to output channel 2	Allocated to output channel 2	Allocated to output channel 2
Biquad filter 3	Allocated to output channel 3	Allocated to output channel 3	Allocated to output channel 3
Biquad filter 4	Allocated to output channel 4	Allocated to output channel 4	Allocated to output channel 4
Biquad filter 5	Not used	Allocated to output channel 1	Allocated to output channel 1
Biquad filter 6	Not used	Allocated to output channel 2	Allocated to output channel 2
Biquad filter 7	Not used	Allocated to output channel 3	Allocated to output channel 3
Biquad filter 8	Not used	Allocated to output channel 4	Allocated to output channel 4
Biquad filter 9	Not used	Not used	Allocated to output channel 1
Biquad filter 10	Not used	Not used	Allocated to output channel 2
Biquad filter 11	Not used	Not used	Allocated to output channel 3
Biquad filter 12	Not used	Not used	Allocated to output channel 4

Table 3-3 shows the biquad filter coefficients mapping to the register space.

Table 3-3. Biquad Filter Coefficients Register Mapping

PROGRAMMABLE BIQUAD FILTER	BIQUAD FILTER COEFFICIENTS REGISTER MAPPING	PROGRAMMABLE BIQUAD FILTER	BIQUAD FILTER COEFFICIENTS REGISTER MAPPING
Biquad filter 1	P2_R8-R27	Biquad filter 7	P3_R8-R27
Biquad filter 2	P2_R28-R47	Biquad filter 8	P3_R28-R47
Biquad filter 3	P2_R48-R67	Biquad filter 9	P3_R48-R67
Biquad filter 4	P2_R68-R87	Biquad filter 10	P3_R68-R87
Biquad filter 5	P2_R88-R107	Biquad filter 11	P3_R88-R107
Biquad filter 6	P2_R108-R127	Biquad filter 12	P3_R108-R127

The DSP_CFG1 Register also determines the number of biquads used through the BIQUAD_CFG bit field shown in Figure 3-4 and Figure 3-5.

Figure 3-4. TLV320ADC3120 and PCM3120-Q1 DSP_CFG1 Register

7	6	5	4	3	2	1	0
DVOL_GANG	BIQUAD_CFG[1:0]		DISABLE_SOFT_STEP	AGC_SEL	Reserved	DRC_EN	EN_AVOID_CLIP
R/W-0h	R/W-2h		R/W-0h	R/W-0h	R/W-0h	R/W-0h	R/W-0h

Figure 3-5. TLV320ADC5120, TLV320ADC6120, PCM 5120-Q1 and PCM6120-Q1 DSP_CFG1 Register

7	6	5	4	3	2	1	0
DVOL_GANG	BIQUAD_CFG[1:0]		DISABLE_SOFT_STEP	AGC_DRE_AGC_SEL	Reserved	DRC_EN	EN_AVOID_CLIP
R/W-0h	R/W-2h		R/W-0h	R/W-0h	R/W-0h	R/W-0h	R/W-0h

Table 3-4. DSP_CFG1 Register Field Descriptions

BIT	FIELD	TYPE	RESET	DESCRIPTION
7	DVOL_GANG	R/W	0h	DVOL control ganged across channels 0d = Each channel has its own DVOL CTRL settings as programmed in the CHx_DVOL bits 1d = All active channels must use the channel 1 DVOL setting (CH1_DVOL) irrespective of whether channel 1 is turned on or not
6-5	BIQUAD_CFG[1:0]	R/W	2h	Number of biquads per channel configuration 0d = No biquads per channel; biquads are all disabled 1d = 1 biquad per channel 2d = 2 biquads per channel 3d = 3 biquads per channel
4	DISABLE_SOFT_STEP	R/W	0h	Soft-stepping disable during DVOL change, mute, and unmute 0d = Soft-stepping enabled 1d = Soft-stepping disabled
3	AGC_SEL (TLV320ADC3120 and PCM3120-Q1)	R/W	0h	AGC selection when is enabled for any channel. 0d = AGC is not selected 1d = AGC is selected
	DRE_AGC_SEL (TLV320ADC5120, TLV320ADC6120, PCM5120-Q1, and PCM6120-Q1)			DRE or AGC selection when is enabled for any channel. 0d = DRE is selected 1d = AGC is selected
2	Reserved	R/W	0h	Reserved
1	DRC_EN	R/W	0h	Dynamic range compression (DRC) same as DRE without gain compensation in digital 0d = DRC disabled. Device can be in DRE or AGC mode depending on DRE_AGC_SEL bit 1d = 1 DRC enabled. Device cannot be in DRE or AGC mode.
0	EN_AVOID_CLIP	R/W	0h	Anti-clipper when channel gain > 0 dB and either of DRE, DRC or AGC mode enabled. 0d = Channel gain is maintained as per user programmed channel gain value 1d = Signal level is compressed to avoid clipping when channel gain > 0 dB and the signal level crosses the programmed threshold setting set in page-4.

3.5 Programmable Coefficient Registers for Digital Biquad Filters 1–6

Table 3-5 shows the programmable coefficient registers for the biquad filters 1 through 6 in Page 2 of the TLV320ADCx120 and PCMx120-Q1 registers.

Table 3-5. Page 0x02 Programmable Coefficient Registers for Biquad Filters 1–6

PAGE 0x2 ADDRESS	REGISTER	RESET VALUE	BIIQUAD FILTER	COEFFICIENT	DESCRIPTION
0x00	PAGE[7:0]	0x00			Device Page Register
0x08	BQ1_N0_BYT1[7:0]	0x7F	Programmable Biquad 1	N0	Biquad 1, N0 coefficient byte[31:24]
0x09	BQ1_N0_BYT2[7:0]	0xFF			biquad 1, N0 coefficient byte[23:16]
0x0A	BQ1_N0_BYT3[7:0]	0xFF			biquad 1, N0 coefficient byte[15:8]
0x0B	BQ1_N0_BYT4[7:0]	0xFF			biquad 1, N0 coefficient byte[7:0]
0x0C	BQ1_N1_BYT1[7:0]	0x00		N1	biquad 1, N1 coefficient byte[31:24]
0x0D	BQ1_N1_BYT2[7:0]	0x00			Biquad 1, N1 coefficient byte[23:16]
0x0E	BQ1_N1_BYT3[7:0]	0x00			Biquad 1, N1 coefficient byte[15:8]
0x0F	BQ1_N1_BYT4[7:0]	0x00		Biquad 1, N1 coefficient byte[7:0]	
0x10	BQ1_N2_BYT1[7:0]	0x00		N2	Biquad 1, N2 coefficient byte[31:24]
0x11	BQ1_N2_BYT2[7:0]	0x00			Biquad 1, N2 coefficient byte[23:16]
0x12	BQ1_N2_BYT3[7:0]	0x00			Biquad 1, N2 coefficient byte[15:8]
0x13	BQ1_N2_BYT4[7:0]	0x00			Biquad 1, N2 coefficient byte[7:0]
0x14	BQ1_D1_BYT1[7:0]	0x00		D1	Biquad 1, D1 coefficient byte[31:24]
0x15	BQ1_D1_BYT2[7:0]	0x00			Biquad 1, D1 coefficient byte[23:16]
0x16	BQ1_D1_BYT3[7:0]	0x00			Biquad 1, D1 coefficient byte[15:8]
0x17	BQ1_D1_BYT4[7:0]	0x00			Biquad 1, D1 coefficient byte[7:0]
0x18	BQ1_D2_BYT1[7:0]	0x00	D2	Biquad 1, D2 coefficient byte[31:24]	
0x19	BQ1_D2_BYT2[7:0]	0x00		Biquad 1, D2 coefficient byte[23:16]	
0x1A	BQ1_D2_BYT3[7:0]	0x00		Biquad 1, D2 coefficient byte[15:8]	
0x1B	BQ1_D2_BYT4[7:0]	0x00		Biquad 1, D2 coefficient byte[7:0]	
0x1C	BQ2_N0_BYT1[7:0]	0x7F	Programmable Biquad 2	N0	Biquad 2, N0 coefficient byte[31:24]
0x1D	BQ2_N0_BYT2[7:0]	0xFF			Biquad 2, N0 coefficient byte[23:16]
0x1E	BQ2_N0_BYT3[7:0]	0xFF			Biquad 2, N0 coefficient byte[15:8]
0x1F	BQ2_N0_BYT4[7:0]	0xFF			Biquad 2, N0 coefficient byte[7:0]
0x20	BQ2_N1_BYT1[7:0]	0x00		N1	Biquad 2, N1 coefficient byte[31:24]
0x21	BQ2_N1_BYT2[7:0]	0x00			Biquad 2, N1 coefficient byte[23:16]
0x22	BQ2_N1_BYT3[7:0]	0x00			Biquad 2, N1 coefficient byte[15:8]
0x23	BQ2_N1_BYT4[7:0]	0x00			Biquad 2, N1 coefficient byte[7:0]
0x24	BQ2_N2_BYT1[7:0]	0x00		N2	Biquad 2, N2 coefficient byte[31:24]
0x25	BQ2_N2_BYT2[7:0]	0x00			Biquad 2, N2 coefficient byte[23:16]
0x26	BQ2_N2_BYT3[7:0]	0x00			Biquad 2, N2 coefficient byte[15:8]
0x27	BQ2_N2_BYT4[7:0]	0x00			Biquad 2, N2 coefficient byte[7:0]
0x28	BQ2_D1_BYT1[7:0]	0x00		D1	Biquad 2, D1 coefficient byte[31:24]
0x29	BQ2_D1_BYT2[7:0]	0x00			Biquad 2, D1 coefficient byte[23:16]
0x2A	BQ2_D1_BYT3[7:0]	0x00			Biquad 2, D1 coefficient byte[15:8]
0x2B	BQ2_D1_BYT4[7:0]	0x00			Biquad 2, D1 coefficient byte[7:0]
0x2C	BQ2_D2_BYT1[7:0]	0x00	D2	Biquad 2, D2 coefficient byte[31:24]	
0x2D	BQ2_D2_BYT2[7:0]	0x00		Biquad 2, D2 coefficient byte[23:16]	
0x2E	BQ2_D2_BYT3[7:0]	0x00		Biquad 2, D2 coefficient byte[15:8]	
0x2F	BQ2_D2_BYT4[7:0]	0x00		Biquad 2, D2 coefficient byte[7:0]	

Table 3-5. Page 0x02 Programmable Coefficient Registers for Biquad Filters 1–6 (continued)

PAGE 0x2 ADDRESS	REGISTER	RESET VALUE	BIQUAD FILTER	COEFFICIENT	DESCRIPTION	
0x30	BQ3_N0_BYT1[7:0]	0x7F	Programmable Biquad 3	N0	Biquad 3, N0 coefficient byte[31:24]	
0x31	BQ3_N0_BYT2[7:0]	0xFF			Biquad 3, N0 coefficient byte[23:16]	
0x32	BQ3_N0_BYT3[7:0]	0xFF			Biquad 3, N0 coefficient byte[15:8]	
0x33	BQ3_N0_BYT4[7:0]	0xFF			Biquad 3, N0 coefficient byte[7:0]	
0x34	BQ3_N1_BYT1[7:0]	0x00		N1	Biquad 3, N1 coefficient byte[31:24]	
0x35	BQ3_N1_BYT2[7:0]	0x00			Biquad 3, N1 coefficient byte[23:16]	
0x36	BQ3_N1_BYT3[7:0]	0x00			Biquad 3, N1 coefficient byte[15:8]	
0x37	BQ3_N1_BYT4[7:0]	0x00			Biquad 3, N1 coefficient byte[7:0]	
0x38	BQ3_N2_BYT1[7:0]	0x00		N2	Biquad 3, N2 coefficient byte[31:24]	
0x39	BQ3_N2_BYT2[7:0]	0x00			Biquad 3, N2 coefficient byte[23:16]	
0x3A	BQ3_N2_BYT3[7:0]	0x00			Biquad 3, N2 coefficient byte[15:8]	
0x3B	BQ3_N2_BYT4[7:0]	0x00			Biquad 3, N2 coefficient byte[7:0]	
0x3C	BQ3_D1_BYT1[7:0]	0x00		D1	Biquad 3, D1 coefficient byte[31:24]	
0x3D	BQ3_D1_BYT2[7:0]	0x00			Biquad 3, D1 coefficient byte[23:16]	
0x3E	BQ3_D1_BYT3[7:0]	0x00			Biquad 3, D1 coefficient byte[15:8]	
0x3F	BQ3_D1_BYT4[7:0]	0x00			Biquad 3, D1 coefficient byte[7:0]	
0x40	BQ3_D2_BYT1[7:0]	0x00		D2	Biquad 3, D2 coefficient byte[31:24]	
0x41	BQ3_D2_BYT2[7:0]	0x00			Biquad 3, D2 coefficient byte[23:16]	
0x42	BQ3_D2_BYT3[7:0]	0x00			Biquad 3, D2 coefficient byte[15:8]	
0x43	BQ3_D2_BYT4[7:0]	0x00			Biquad 3, D2 coefficient byte[7:0]	
0x44	BQ4_N0_BYT1[7:0]	0x7F		Programmable Biquad 4	N0	Biquad 4, N0 coefficient byte[31:24]
0x45	BQ4_N0_BYT2[7:0]	0xFF				Biquad 4, N0 coefficient byte[23:16]
0x46	BQ4_N0_BYT3[7:0]	0xFF				Biquad 4, N0 coefficient byte[15:8]
0x47	BQ4_N0_BYT4[7:0]	0xFF				Biquad 4, N0 coefficient byte[7:0]
0x48	BQ4_N1_BYT1[7:0]	0x00	N1		Biquad 4, N1 coefficient byte[31:24]	
0x49	BQ4_N1_BYT2[7:0]	0x00			Biquad 4, N1 coefficient byte[23:16]	
0x4A	BQ4_N1_BYT3[7:0]	0x00			Biquad 4, N1 coefficient byte[15:8]	
0x4B	BQ4_N1_BYT4[7:0]	0x00			Biquad 4, N1 coefficient byte[7:0]	
0x4C	BQ4_N2_BYT1[7:0]	0x00	N2		Biquad 4, N2 coefficient byte[31:24]	
0x4D	BQ4_N2_BYT2[7:0]	0x00			Biquad 4, N2 coefficient byte[23:16]	
0x4E	BQ4_N2_BYT3[7:0]	0x00			Biquad 4, N2 coefficient byte[15:8]	
0x4F	BQ4_N2_BYT4[7:0]	0x00			Biquad 4, N2 coefficient byte[7:0]	
0x50	BQ4_D1_BYT1[7:0]	0x00	D1		Biquad 4, D1 coefficient byte[31:24]	
0x51	BQ4_D1_BYT2[7:0]	0x00			Biquad 4, D1 coefficient byte[23:16]	
0x52	BQ4_D1_BYT3[7:0]	0x00			Biquad 4, D1 coefficient byte[15:8]	
0x53	BQ4_D1_BYT4[7:0]	0x00			Biquad 4, D1 coefficient byte[7:0]	
0x54	BQ4_D2_BYT1[7:0]	0x00	D2		Biquad 4, D2 coefficient byte[31:24]	
0x55	BQ4_D2_BYT2[7:0]	0x00			Biquad 4, D2 coefficient byte[23:16]	
0x56	BQ4_D2_BYT3[7:0]	0x00			Biquad 4, D2 coefficient byte[15:8]	
0x57	BQ4_D2_BYT4[7:0]	0x00			Biquad 4, D2 coefficient byte[7:0]	

Table 3-5. Page 0x02 Programmable Coefficient Registers for Biquad Filters 1–6 (continued)

PAGE 0x2 ADDRESS	REGISTER	RESET VALUE	BIQUAD FILTER	COEFFICIENT	DESCRIPTION
0x58	BQ5_N0_BYT1[7:0]	0x7F	Programmable Biquad 5	N0	Biquad 5, N0 coefficient byte[31:24]
0x59	BQ5_N0_BYT2[7:0]	0xFF			Biquad 5, N0 coefficient byte[23:16]
0x5A	BQ5_N0_BYT3[7:0]	0xFF			Biquad 5, N0 coefficient byte[15:8]
0x5B	BQ5_N0_BYT4[7:0]	0xFF			Biquad 5, N0 coefficient byte[7:0]
0x5C	BQ5_N1_BYT1[7:0]	0x00		N1	Biquad 5, N1 coefficient byte[31:24]
0x5D	BQ5_N1_BYT2[7:0]	0x00			Biquad 5, N1 coefficient byte[23:16]
0x5E	BQ5_N1_BYT3[7:0]	0x00			Biquad 5, N1 coefficient byte[15:8]
0x5F	BQ5_N1_BYT4[7:0]	0x00			Biquad 5, N1 coefficient byte[7:0]
0x60	BQ5_N2_BYT1[7:0]	0x00		N2	Biquad 5, N2 coefficient byte[31:24]
0x61	BQ5_N2_BYT2[7:0]	0x00			Biquad 5, N2 coefficient byte[23:16]
0x62	BQ5_N2_BYT3[7:0]	0x00			Biquad 5, N2 coefficient byte[15:8]
0x63	BQ5_N2_BYT4[7:0]	0x00			Biquad 5, N2 coefficient byte[7:0]
0x64	BQ5_D1_BYT1[7:0]	0x00		D1	Biquad 5, D1 coefficient byte[31:24]
0x65	BQ5_D1_BYT2[7:0]	0x00			Biquad 5, D1 coefficient byte[23:16]
0x66	BQ5_D1_BYT3[7:0]	0x00			Biquad 5, D1 coefficient byte[15:8]
0x67	BQ5_D1_BYT4[7:0]	0x00			Biquad 5, D1 coefficient byte[7:0]
0x68	BQ5_D2_BYT1[7:0]	0x00		D2	Biquad 5, D2 coefficient byte[31:24]
0x69	BQ5_D2_BYT2[7:0]	0x00			Biquad 5, D2 coefficient byte[23:16]
0x6A	BQ5_D2_BYT3[7:0]	0x00			Biquad 5, D2 coefficient byte[15:8]
0x6B	BQ5_D2_BYT4[7:0]	0x00			Biquad 5, D2 coefficient byte[7:0]
0x6C	BQ6_N0_BYT1[7:0]	0x7F	Programmable Biquad 6	N0	Biquad 6, N0 coefficient byte[31:24]
0x6D	BQ6_N0_BYT2[7:0]	0xFF			Biquad 6, N0 coefficient byte[23:16]
0x6E	BQ6_N0_BYT3[7:0]	0xFF			Biquad 6, N0 coefficient byte[15:8]
0x6F	BQ6_N0_BYT4[7:0]	0xFF			Biquad 6, N0 coefficient byte[7:0]
0x70	BQ6_N1_BYT1[7:0]	0x00		N1	Biquad 6, N1 coefficient byte[31:24]
0x71	BQ6_N1_BYT2[7:0]	0x00			Biquad 6, N1 coefficient byte[23:16]
0x72	BQ6_N1_BYT3[7:0]	0x00			Biquad 6, N1 coefficient byte[15:8]
0x73	BQ6_N1_BYT4[7:0]	0x00			Biquad 6, N1 coefficient byte[7:0]
0x74	BQ6_N2_BYT1[7:0]	0x00		N2	Biquad 6, N2 coefficient byte[31:24]
0x75	BQ6_N2_BYT2[7:0]	0x00			Biquad 6, N2 coefficient byte[23:16]
0x76	BQ6_N2_BYT3[7:0]	0x00			Biquad 6, N2 coefficient byte[15:8]
0x77	BQ6_N2_BYT4[7:0]	0x00			Biquad 6, N2 coefficient byte[7:0]
0x78	BQ6_D1_BYT1[7:0]	0x00		D1	Biquad 6, D1 coefficient byte[31:24]
0x79	BQ6_D1_BYT2[7:0]	0x00			Biquad 6, D1 coefficient byte[23:16]
0x7A	BQ6_D1_BYT3[7:0]	0x00			Biquad 6, D1 coefficient byte[15:8]
0x7B	BQ6_D1_BYT4[7:0]	0x00			Biquad 6, D1 coefficient byte[7:0]
0x7C	BQ6_D2_BYT1[7:0]	0x00		D2	Biquad 6, D2 coefficient byte[31:24]
0x7D	BQ6_D2_BYT2[7:0]	0x00			Biquad 6, D2 coefficient byte[23:16]
0x7E	BQ6_D2_BYT3[7:0]	0x00			Biquad 6, D2 coefficient byte[15:8]
0x7F	BQ6_D2_BYT4[7:0]	0x00			Biquad 6, D2 coefficient byte[7:0]

3.6 Programmable Coefficient Registers for Digital Biquad Filters 7–12

Table 3-6 shows the programmable coefficient registers for the biquad filters 7 through 12 in Page 3 of the TLV320ADCx120 and PCMX120-Q1 registers.

Table 3-6. Page 0x03 Programmable Coefficient Registers for Biquad Filters 7–12

PAGE 0x3 ADDRESS	REGISTER	RESET	BIQUAD FILTER	COEFFICIENT	DESCRIPTION
0x00	PAGE[7:0]	0x00			Device Page Register
0x08	BQ7_N0_BYT1[7:0]	0x7F	Programmable Biquad 7	N0	Programmable biquad 7, N0 coefficient byte[31:24]
0x09	BQ7_N0_BYT2[7:0]	0xFF			Biquad 7, N0 coefficient byte[23:16]
0x0A	BQ7_N0_BYT3[7:0]	0xFF			Biquad 7, N0 coefficient byte[15:8]
0x0B	BQ7_N0_BYT4[7:0]	0xFF			Biquad 7, N0 coefficient byte[7:0]
0x0C	BQ7_N1_BYT1[7:0]	0x00		N1	Biquad 7, N1 coefficient byte[31:24]
0x0D	BQ7_N1_BYT2[7:0]	0x00			Biquad 7, N1 coefficient byte[23:16]
0x0E	BQ7_N1_BYT3[7:0]	0x00			Biquad 7, N1 coefficient byte[15:8]
0x0F	BQ7_N1_BYT4[7:0]	0x00			Biquad 7, N1 coefficient byte[7:0]
0x10	BQ7_N2_BYT1[7:0]	0x00		N2	Biquad 7, N2 coefficient byte[31:24]
0x11	BQ7_N2_BYT2[7:0]	0x00			Biquad 7, N2 coefficient byte[23:16]
0x12	BQ7_N2_BYT3[7:0]	0x00			Biquad 7, N2 coefficient byte[15:8]
0x13	BQ7_N2_BYT4[7:0]	0x00			Biquad 7, N2 coefficient byte[7:0]
0x14	BQ7_D1_BYT1[7:0]	0x00		D1	Biquad 7, D1 coefficient byte[31:24]
0x15	BQ7_D1_BYT2[7:0]	0x00			Biquad 7, D1 coefficient byte[23:16]
0x16	BQ7_D1_BYT3[7:0]	0x00			Biquad 7, D1 coefficient byte[15:8]
0x17	BQ7_D1_BYT4[7:0]	0x00			Biquad 7, D1 coefficient byte[7:0]
0x18	BQ7_D2_BYT1[7:0]	0x00		D2	Biquad 7, D2 coefficient byte[31:24]
0x19	BQ7_D2_BYT2[7:0]	0x00			Biquad 7, D2 coefficient byte[23:16]
0x1A	BQ7_D2_BYT3[7:0]	0x00			Biquad 7, D2 coefficient byte[15:8]
0x1B	BQ7_D2_BYT4[7:0]	0x00			Biquad 7, D2 coefficient byte[7:0]
0x1C	BQ8_N0_BYT1[7:0]	0x7F	Programmable Biquad 8	N0	Biquad 8, N0 coefficient byte[31:24]
0x1D	BQ8_N0_BYT2[7:0]	0xFF			Biquad 8, N0 coefficient byte[23:16]
0x1E	BQ8_N0_BYT3[7:0]	0xFF			Biquad 8, N0 coefficient byte[15:8]
0x1F	BQ8_N0_BYT4[7:0]	0xFF			Biquad 8, N0 coefficient byte[7:0]
0x20	BQ8_N1_BYT1[7:0]	0x00		N1	Biquad 8, N1 coefficient byte[31:24]
0x21	BQ8_N1_BYT2[7:0]	0x00			Biquad 8, N1 coefficient byte[23:16]
0x22	BQ8_N1_BYT3[7:0]	0x00			Biquad 8, N1 coefficient byte[15:8]
0x23	BQ8_N1_BYT4[7:0]	0x00			Biquad 8, N1 coefficient byte[7:0]
0x24	BQ8_N2_BYT1[7:0]	0x00		N2	Biquad 8, N2 coefficient byte[31:24]
0x25	BQ8_N2_BYT2[7:0]	0x00			Biquad 8, N2 coefficient byte[23:16]
0x26	BQ8_N2_BYT3[7:0]	0x00			Biquad 8, N2 coefficient byte[15:8]
0x27	BQ8_N2_BYT4[7:0]	0x00			Biquad 8, N2 coefficient byte[7:0]
0x28	BQ8_D1_BYT1[7:0]	0x00		D1	Biquad 8, D1 coefficient byte[31:24]
0x29	BQ8_D1_BYT2[7:0]	0x00			Biquad 8, D1 coefficient byte[23:16]
0x2A	BQ8_D1_BYT3[7:0]	0x00			Biquad 8, D1 coefficient byte[15:8]
0x2B	BQ8_D1_BYT4[7:0]	0x00			Biquad 8, D1 coefficient byte[7:0]
0x2C	BQ8_D2_BYT1[7:0]	0x00		D2	Biquad 8, D2 coefficient byte[31:24]
0x2D	BQ8_D2_BYT2[7:0]	0x00			Biquad 8, D2 coefficient byte[23:16]
0x2E	BQ8_D2_BYT3[7:0]	0x00			Biquad 8, D2 coefficient byte[15:8]
0x2F	BQ8_D2_BYT4[7:0]	0x00			Biquad 8, D2 coefficient byte[7:0]

Table 3-6. Page 0x03 Programmable Coefficient Registers for Biquad Filters 7–12 (continued)

PAGE 0x3 ADDRESS	REGISTER	RESET	BIQUAD FILTER	COEFFICIENT	DESCRIPTION
0x30	BQ9_N0_BYT1[7:0]	0x7F	Programmable Biquad 9	N0	Biquad 9, N0 coefficient byte[31:24]
0x31	BQ9_N0_BYT2[7:0]	0xFF			Biquad 9, N0 coefficient byte[23:16]
0x32	BQ9_N0_BYT3[7:0]	0xFF			Biquad 9, N0 coefficient byte[15:8]
0x33	BQ9_N0_BYT4[7:0]	0xFF			Biquad 9, N0 coefficient byte[7:0]
0x34	BQ9_N1_BYT1[7:0]	0x00		N1	Biquad 9, N1 coefficient byte[31:24]
0x35	BQ9_N1_BYT2[7:0]	0x00			Biquad 9, N1 coefficient byte[23:16]
0x36	BQ9_N1_BYT3[7:0]	0x00			Biquad 9, N1 coefficient byte[15:8]
0x37	BQ9_N1_BYT4[7:0]	0x00			Biquad 9, N1 coefficient byte[7:0]
0x38	BQ9_N2_BYT1[7:0]	0x00		N2	Biquad 9, N2 coefficient byte[31:24]
0x39	BQ9_N2_BYT2[7:0]	0x00			Biquad 9, N2 coefficient byte[23:16]
0x3A	BQ9_N2_BYT3[7:0]	0x00			Biquad 9, N2 coefficient byte[15:8]
0x3B	BQ9_N2_BYT4[7:0]	0x00			Biquad 9, N2 coefficient byte[7:0]
0x3C	BQ9_D1_BYT1[7:0]	0x00		D1	Biquad 9, D1 coefficient byte[31:24]
0x3D	BQ9_D1_BYT2[7:0]	0x00			Biquad 9, D1 coefficient byte[23:16]
0x3E	BQ9_D1_BYT3[7:0]	0x00			Biquad 9, D1 coefficient byte[15:8]
0x3F	BQ9_D1_BYT4[7:0]	0x00			Biquad 9, D1 coefficient byte[7:0]
0x40	BQ9_D2_BYT1[7:0]	0x00		D2	Biquad 9, D2 coefficient byte[31:24]
0x41	BQ9_D2_BYT2[7:0]	0x00			Biquad 9, D2 coefficient byte[23:16]
0x42	BQ9_D2_BYT3[7:0]	0x00			Biquad 9, D2 coefficient byte[15:8]
0x43	BQ9_D2_BYT4[7:0]	0x00			Biquad 9, D2 coefficient byte[7:0]
0x44	BQ10_N0_BYT1[7:0]	0x7F	Programmable Biquad 10	N0	Biquad 10, N0 coefficient byte[31:24]
0x45	BQ10_N0_BYT2[7:0]	0xFF			Biquad 10, N0 coefficient byte[23:16]
0x46	BQ10_N0_BYT3[7:0]	0xFF			Biquad 10, N0 coefficient byte[15:8]
0x47	BQ10_N0_BYT4[7:0]	0xFF			Biquad 10, N0 coefficient byte[7:0]
0x48	BQ10_N1_BYT1[7:0]	0x00		N1	Biquad 10, N1 coefficient byte[31:24]
0x49	BQ10_N1_BYT2[7:0]	0x00			Biquad 10, N1 coefficient byte[23:16]
0x4A	BQ10_N1_BYT3[7:0]	0x00			Biquad 10, N1 coefficient byte[15:8]
0x4B	BQ10_N1_BYT4[7:0]	0x00			Biquad 10, N1 coefficient byte[7:0]
0x4C	BQ10_N2_BYT1[7:0]	0x00		N2	Biquad 10, N2 coefficient byte[31:24]
0x4D	BQ10_N2_BYT2[7:0]	0x00			Biquad 10, N2 coefficient byte[23:16]
0x4E	BQ10_N2_BYT3[7:0]	0x00			Biquad 10, N2 coefficient byte[15:8]
0x4F	BQ10_N2_BYT4[7:0]	0x00			Biquad 10, N2 coefficient byte[7:0]
0x50	BQ10_D1_BYT1[7:0]	0x00		D1	Biquad 10, D1 coefficient byte[31:24]
0x51	BQ10_D1_BYT2[7:0]	0x00			Biquad 10, D1 coefficient byte[23:16]
0x52	BQ10_D1_BYT3[7:0]	0x00			Biquad 10, D1 coefficient byte[15:8]
0x53	BQ10_D1_BYT4[7:0]	0x00			Biquad 10, D1 coefficient byte[7:0]
0x54	BQ10_D2_BYT1[7:0]	0x00		D2	Biquad 10, D2 coefficient byte[31:24]
0x55	BQ10_D2_BYT2[7:0]	0x00			Biquad 10, D2 coefficient byte[23:16]
0x56	BQ10_D2_BYT3[7:0]	0x00			Biquad 10, D2 coefficient byte[15:8]
0x57	BQ10_D2_BYT4[7:0]	0x00			Biquad 10, D2 coefficient byte[7:0]

Table 3-6. Page 0x03 Programmable Coefficient Registers for Biquad Filters 7–12 (continued)

PAGE 0x3 ADDRESS	REGISTER	RESET	BIQUAD FILTER	COEFFICIENT	DESCRIPTION	
0x58	BQ11_N0_BYT1[7:0]	0x7F	Programmable Biquad 11	N0	Biquad 11, N0 coefficient byte[31:24]	
0x59	BQ11_N0_BYT2[7:0]	0xFF			Biquad 11, N0 coefficient byte[23:16]	
0x5A	BQ11_N0_BYT3[7:0]	0xFF			Biquad 11, N0 coefficient byte[15:8]	
0x5B	BQ11_N0_BYT4[7:0]	0xFF			Biquad 11, N0 coefficient byte[7:0]	
0x5C	BQ11_N1_BYT1[7:0]	0x00		N1	Biquad 11, N1 coefficient byte[31:24]	
0x5D	BQ11_N1_BYT2[7:0]	0x00			Biquad 11, N1 coefficient byte[23:16]	
0x5E	BQ11_N1_BYT3[7:0]	0x00			Biquad 11, N1 coefficient byte[15:8]	
0x5F	BQ11_N1_BYT4[7:0]	0x00			Biquad 11, N1 coefficient byte[7:0]	
0x60	BQ11_N2_BYT1[7:0]	0x00		N2	Biquad 11, N2 coefficient byte[31:24]	
0x61	BQ11_N2_BYT2[7:0]	0x00			Biquad 11, N2 coefficient byte[23:16]	
0x62	BQ11_N2_BYT3[7:0]	0x00			Biquad 11, N2 coefficient byte[15:8]	
0x63	BQ11_N2_BYT4[7:0]	0x00			Biquad 11, N2 coefficient byte[7:0]	
0x64	BQ11_D1_BYT1[7:0]	0x00		D1	Biquad 11, D1 coefficient byte[31:24]	
0x65	BQ11_D1_BYT2[7:0]	0x00			Biquad 11, D1 coefficient byte[23:16]	
0x66	BQ11_D1_BYT3[7:0]	0x00			Biquad 11, D1 coefficient byte[15:8]	
0x67	BQ11_D1_BYT4[7:0]	0x00			Biquad 11, D1 coefficient byte[7:0]	
0x68	BQ11_D2_BYT1[7:0]	0x00		D2	Biquad 11, D2 coefficient byte[31:24]	
0x69	BQ11_D2_BYT2[7:0]	0x00			Biquad 11, D2 coefficient byte[23:16]	
0x6A	BQ11_D2_BYT3[7:0]	0x00			Biquad 11, D2 coefficient byte[15:8]	
0x6B	BQ11_D2_BYT4[7:0]	0x00			Biquad 11, D2 coefficient byte[7:0]	
0x6C	BQ12_N0_BYT1[7:0]	0x7F		Programmable Biquad 12	N0	Biquad 12, N0 coefficient byte[31:24]
0x6D	BQ12_N0_BYT2[7:0]	0xFF				Biquad 12, N0 coefficient byte[23:16]
0x6E	BQ12_N0_BYT3[7:0]	0xFF				Biquad 12, N0 coefficient byte[15:8]
0x6F	BQ12_N0_BYT4[7:0]	0xFF				Biquad 12, N0 coefficient byte[7:0]
0x70	BQ12_N1_BYT1[7:0]	0x00	N1		Biquad 12, N1 coefficient byte[31:24]	
0x71	BQ12_N1_BYT2[7:0]	0x00			Biquad 12, N1 coefficient byte[23:16]	
0x72	BQ12_N1_BYT3[7:0]	0x00			Biquad 12, N1 coefficient byte[15:8]	
0x73	BQ12_N1_BYT4[7:0]	0x00			Biquad 12, N1 coefficient byte[7:0]	
0x74	BQ12_N2_BYT1[7:0]	0x00	N2		Biquad 12, N2 coefficient byte[31:24]	
0x75	BQ12_N2_BYT2[7:0]	0x00			Biquad 12, N2 coefficient byte[23:16]	
0x76	BQ12_N2_BYT3[7:0]	0x00			Biquad 12, N2 coefficient byte[15:8]	
0x77	BQ12_N2_BYT4[7:0]	0x00			Biquad 12, N2 coefficient byte[7:0]	
0x78	BQ12_D1_BYT1[7:0]	0x00	D1		Biquad 12, D1 coefficient byte[31:24]	
0x79	BQ12_D1_BYT2[7:0]	0x00			Biquad 12, D1 coefficient byte[23:16]	
0x7A	BQ12_D1_BYT3[7:0]	0x00			Biquad 12, D1 coefficient byte[15:8]	
0x7B	BQ12_D1_BYT4[7:0]	0x00			Biquad 12, D1 coefficient byte[7:0]	
0x7C	BQ12_D2_BYT1[7:0]	0x00	D2		Biquad 12, D2 coefficient byte[31:24]	
0x7D	BQ12_D2_BYT2[7:0]	0x00			Biquad 12, D2 coefficient byte[23:16]	
0x7E	BQ12_D2_BYT3[7:0]	0x00			Biquad 12, D2 coefficient byte[15:8]	
0x7F	BQ12_D2_BYT4[7:0]	0x00			Biquad 12, D2 coefficient byte[7:0]	

4 How to Program the Digital Biquad Filters on the TLV320ADCx120 and PCMx120-Q1

Coefficients of Digital Biquad Filters can be implemented by running a command script to send an I2C command to the EVM. The following script segment shows how to program the coefficients for a set of filters for 5-dB boost at 500 Hz with a bandwidth of 400 Hz, cut –5 dB at 2 kHz with 3-kHz bandwidth, and a Notch filter at 60 Hz with 50-Hz bandwidth for channel 1.

```
# Select Page 2
w 9C 00 02
# Write Coefficient N0, N1, N2, D1, D2 for Biquad Filter 1
w 9C 08 7f ff ff ff 85 dc e2 7d 74 cc 68 8f 7c 77 a7 18 86 87 f4 ee
# Write Coefficient N0, N1, N2, D1, D2 for Biquad Filter 5
w 9C 58 71 80 7d b6 a4 5b f4 41 4c 3e c3 29 5b a4 0b bf c2 40 bf 20
# Select Page 3
w 9C 00 03
# Write Coefficient N0, N1, N2, D1, D2 for Biquad Filter 9
w 9C 30 7f 95 1d c9 80 6b e4 18 7f 95 1d c9 7f 94 1b e8 80 d5 c4 6d
```

5 Typical Audio Applications for Biquad Filtering

In audio systems, biquad filters offer flexible frequency response filters for the following applications:

- Parametric equalizers
- Crossover networks
- Voice boost
- Bass boost
- Removing 50 Hz–60 Hz hum with notch filters

5.1 Parametric Equalizers

Cascading several parametric equalizers provide frequency shaping control of the input signal with three control settings: gain, center frequency, and bandwidth or Q-factor. Parametric equalizers control the tone and sound to flatten or match different input sources during mixing or provide particular effect to the input signal. Equalization usually compensates for the physical response of microphones or speakers, balances the tone of several instruments, or changes the timbre of an instrument since these filters provide very selective frequency adjustment during mixing or a specific range effect during recording. For example, small earbud headphones might not be able to reproduce low.

6 Crossover Networks

Crossover networks separate or join together several specific frequency bands. They are typically used in speaker systems to separate the low-, mid-, and high-range frequencies to respective drive woofers, midrange, or tweeter drivers. These filters protect the drivers from wasteful, noise inducing, or harmful frequencies that the driver is not designed to handle. For example, there is no need to send high frequency to a woofer. The woofer is not able to reproduce high frequencies and just adds distortion. A tweeter can be damaged by strong low frequencies, thus it is best to filter these before sending the signal to these drivers. Linkwitz Riley implementations are tailored to produce an overall gain of 0 dB at the crossover frequency when their low-pass and high-pass filters combine together so the overall musical tone is not changed during reproduction.

7 Voice Boost

Human speech has a usable frequency range of 200 Hz–8 kHz. Male speech bandwidth is roughly 200 Hz–6 kHz while female speech bandwidth is roughly 400 Hz–8 kHz. To improve speech intelligibility, a band-pass filter or parametric equalizer boosts the voice-band frequencies while suppressing other frequencies to lower background noise or other musical instruments.

8 Bass Boost

Simple Bass shelf filters provide a bass boost. These are typically used to compensate for speakers that have difficulty reproducing low frequencies. For example, small speakers might require a bass boost to improve low-frequency reproduction.

9 Removing 50 Hz–60 Hz Hum With Notch Filters

Notch filters cut a specific single frequency. These filters are highly efficient for removing 50 Hz or 60 Hz power line hum, transformer hum, room resonance, acoustic feedback, and any undesired specific frequency component introduced by the room acoustics or recording equipment.

A Digital Filter Design Techniques

A.A Analog Filters

PurePath Console Digital Filter design uses analog filter design techniques and transposes them to the digital domain. The analog filters are represented in the S-domain. Through the bi-linear transformation, these analog filters are converted from the S-domain to the digital Z-domain. In these filters, each pole of the filter provides a –6 dB per octave or –10 dB per decade slope in the frequency response. Each zero of the filter provides a +6 dB per octave or +10 dB per decade slope in the frequency response. [Table A-1](#) shows the S-domain transfer function of the PurePath Console filter design. Note that $Q = f_c / \text{Bandwidth}$, where f_c is the center frequency.

Table A-1. PurePath™ Console Filter Transfer Function

FILTER TYPE	TRANSFER FUNCTION	WHEN TO USE
Band Pass	$H(s) = \frac{\frac{w_c}{Q} s}{s^2 + \frac{w_c}{Q} s + w_c^2}$	Filters a set of frequencies given by bandwidth and center frequency
Bass Shelf	$H(s) = \frac{w_c^2}{s^2 + w_c s + w_c^2}$	Applies the specified gain at low frequency up to the specified cutoff frequency
Equalizer (Bandwidth)	$H(s) = \frac{\frac{w_c}{Q} s}{s^2 + \frac{w_c}{Q} s + w_c^2}$	Band-pass filter at the specified center frequency and pass-band width, with the specified gain
Equalizer (Q Factor)		Band-pass filter at the specified center frequency and quality factor, with the specified gain. The quality factor is the center frequency divided by the pass-band width.
Gain	$H(s) = \frac{s^2 - \frac{w_c}{Q} s + w_c^2}{s^2 + \frac{w_c}{Q} s + w_c^2}$	All pass filter at the specified gain
High-Pass Butterworth 1	$H(s) = \frac{s^2}{s^2 + \sqrt{2} w_c s + w_c^2}$	Flat pass-band and stop-band response with a –10 dB / decade slope past the cutoff frequency
High-Pass Butterworth 2		Flat pass-band and stop-band response with a –20 dB / decade past the cutoff frequency
High-Pass Bessel 2	$H(s) = \frac{s^2}{s^2 + \sqrt{3} w_c s + w_c^2}$	Maximally flat magnitude and phase in pass band with constant group delay at the expense of the greatest transition band
High-Pass Linkwitz Riley 2	$H(s) = \frac{(w_c s)^2}{(1 + w_c s)^2}$	Use in crossover systems with the same cutoff frequency for low pass and high pass. These filters overall gain is 0 dB at the crossover point.
High-Pass Variable Q 2	$H(s) = \frac{s^2}{s^2 + \frac{w_c}{Q} s + w_c^2}$	Second-order high-pass filter at the specified center frequency, gain, and quality factor. The quality factor is the center frequency divided by the pass-band width.
High-Pass Chebyshev	$H(s) = \frac{s^2}{\sqrt{2} s^2 + 0.911 w_c s + w_c^2}$	Sharper transition band than Butterworth at the expense of ripple in the pass band.
Low-Pass Butterworth 1	$H(s) = \frac{w_c^2}{s^2 + \sqrt{2} w_c s + w_c^2}$	Flat pass-band and stop-band response with a –10 dB / decade slope up to the cutoff frequency
Low-Pass Butterworth 2		Flat pass-band and stop-band response with a –20 dB / decade up to the cutoff frequency
Low-Pass Bessel 2	$H(s) = \frac{w_c^2}{s^2 + \sqrt{3} w_c s + w_c^2}$	Maximally flat magnitude and phase in pass band with constant group delay at the expense of the greatest transition band
Low-Pass Linkwitz Riley 2	$H(s) = \frac{1}{(1 + w_c s)^2}$	Use in crossover systems with the same cutoff frequency for low pass and high pass. These filters overall gain is 0 dB at the crossover point.

Table A-1. PurePath™ Console Filter Transfer Function (continued)

FILTER TYPE	TRANSFER FUNCTION	WHEN TO USE
Low-Pass Variable Q 2	$H(s) = \frac{w_c^2}{s^2 + \frac{w_c}{Q}s + w_c^2}$	Second-order low-pass filter at the specified center frequency, gain, and quality factor. The quality factor is the center frequency divided by the pass-band width.
Low-Pass Chebyshev	$H(s) = \frac{w_c^2}{\sqrt{2}s^2 + 0.911w_c s + w_c^2}$	Sharper transition band than Butterworth at the expense of ripple in the pass band
Notch	$H(s) = \frac{s^2 + w_c^2}{s^2 + \frac{w_c}{Q}s + w_c^2}$	Filter or null a specific frequency
Phase Shift	$H(s) = \frac{1 - s/w_c}{1 + s/w_c}$	Change the phase of a signal
Treble Shelf	$H(s) = \frac{s^2}{s^2 + w_c s + w_c^2}$	Applies the specified gain at the high frequency past the specified cutoff frequency

B Related Documentation

For related documentation see the following:

- PCM6120-Q1
 - Texas Instruments, [PCM6120-Q1 2-Channel, 768-kHz, Burr-Brown Audio ADC data sheet](#)
- PCM5120-Q1
 - Texas Instruments, [PCM5120-Q1 2-Channel, 768-kHz, Burr-Brown Audio ADC data sheet](#)
- PCM3120-Q1
 - Texas Instruments, [PCM3120-Q1 2-Channel, 768-kHz, Burr-Brown Audio ADC data sheet](#)
- TLV320ADC6120
 - Texas Instruments, [TLV320ADC6120 2-Channel, 768-kHz, Burr-Brown™ Audio ADC data sheet](#)
 - Texas Instruments, [TLV320ADC6120 stereo-channel, 768-kHz, Burr-Brown™ audio ADC with 106-dB SNR evaluation module](#)
- TLV320ADC5120
 - Texas Instruments, [TLV320ADC5120 2-Channel, 768-kHz, Burr-Brown™ Audio ADC data sheet](#)
 - Texas Instruments, [TLV320ADC5120 stereo-channel, 768-kHz, Burr-Brown™ audio ADC with 106-dB SNR evaluation module](#)
- TLV320ADC3120
 - Texas Instruments, [TLV320ADC3120 2-Channel, 768-kHz, Burr-Brown™ Audio ADC data sheet](#)
 - Texas Instruments, [TLV320ADC3120 stereo-channel, 768-kHz, Burr-Brown™ audio ADC with 106-dB SNR evaluation module](#)
- Texas Instruments, [ADCx120EVM-PDK User's Guide](#)
- Texas Instruments, [PurePath™ Console](#)

B Revision History

NOTE: Page numbers for previous revisions may differ from page numbers in the current version.

Changes from Revision A (September 2021) to Revision B (April 2022)	Page
• Added PCMx120-Q1 devices.....	1
<hr/>	
Changes from Revision * (May 2021) to Revision A (September 2021)	Page
• Updated header cell content in Table 3-2	8

IMPORTANT NOTICE AND DISCLAIMER

TI PROVIDES TECHNICAL AND RELIABILITY DATA (INCLUDING DATA SHEETS), DESIGN RESOURCES (INCLUDING REFERENCE DESIGNS), APPLICATION OR OTHER DESIGN ADVICE, WEB TOOLS, SAFETY INFORMATION, AND OTHER RESOURCES "AS IS" AND WITH ALL FAULTS, AND DISCLAIMS ALL WARRANTIES, EXPRESS AND IMPLIED, INCLUDING WITHOUT LIMITATION ANY IMPLIED WARRANTIES OF MERCHANTABILITY, FITNESS FOR A PARTICULAR PURPOSE OR NON-INFRINGEMENT OF THIRD PARTY INTELLECTUAL PROPERTY RIGHTS.

These resources are intended for skilled developers designing with TI products. You are solely responsible for (1) selecting the appropriate TI products for your application, (2) designing, validating and testing your application, and (3) ensuring your application meets applicable standards, and any other safety, security, regulatory or other requirements.

These resources are subject to change without notice. TI grants you permission to use these resources only for development of an application that uses the TI products described in the resource. Other reproduction and display of these resources is prohibited. No license is granted to any other TI intellectual property right or to any third party intellectual property right. TI disclaims responsibility for, and you will fully indemnify TI and its representatives against, any claims, damages, costs, losses, and liabilities arising out of your use of these resources.

TI's products are provided subject to [TI's Terms of Sale](#) or other applicable terms available either on ti.com or provided in conjunction with such TI products. TI's provision of these resources does not expand or otherwise alter TI's applicable warranties or warranty disclaimers for TI products.

TI objects to and rejects any additional or different terms you may have proposed.

Mailing Address: Texas Instruments, Post Office Box 655303, Dallas, Texas 75265
Copyright © 2022, Texas Instruments Incorporated