

Time of Flight and LIDAR - Optical Front End Design



Optical Time-of-Flight (ToF) LIDAR (Light Detection and Ranging) systems are used in a wide variety of products including range finders, speed measurement devices, surveying equipment, robotics, drones, 3D mapping, and automotive advanced driver assistance systems (ADAS). Optical ToF systems consist of a light transmitter, usually in the form of a laser, and a light receiver. These systems measure distance by emitting a pulse of light onto an object and receiving the reflected pulse of light from the object. The time it takes for the light to travel to and from the object can be used to calculate the distance between the transmitter, receiver, and the object. [Figure 1](#) shows a high-level diagram of an optical ToF system.

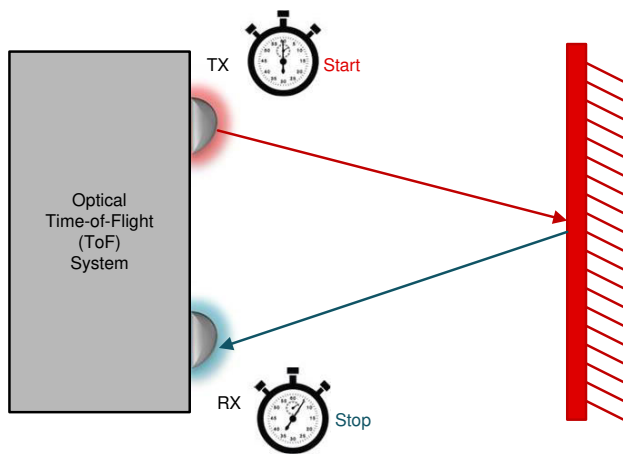

Figure 1. Optical Time-of-Flight System Diagram

Two main optical ToF receive path system architectures include time-to-digital converter (TDC) based systems and analog-to-digital converter (ADC) based systems. These two architectures are both viable in implementing optical ToF systems and each comes with different advantages and tradeoffs.

A TDC-based system employs a TDC like TI's [TDC7201](#) device to perform a very precise stop watch function to measure the elapsed time between a start pulse and a stop pulse. [Figure 2](#) shows a block diagram of this system.

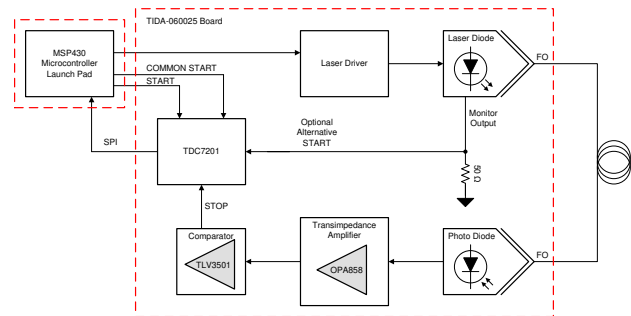

Figure 2. DC-Based Optical ToF System Diagram

A low-power microcontroller like TI's [MSP430F5529](#) can be used in conjunction with the TDC7201 device to initiate the transmit laser pulse and to process the ToF information collected from the TDC. The receive path also requires a transimpedance amplifier or TIA like the TI [OPA858](#) 5.5-GHz operational amplifier to perform a current-to-voltage conversion on the signal received from the photodiode. The low bias current CMOS inputs, and a low noise of $2.5 \text{ nV}/\sqrt{\text{Hz}}$ of the OPA858 device make it ideal for use as a transimpedance amplifier (TIA) in this application. Depending on the capacitance of the photodiode used in the system, the OPA858 can achieve over 250 MHz of closed-loop bandwidth with a gain of 10 k Ω . The TIA is also available in a very small 2 mm \times 2 mm, 8-pin package for space-constrained or multi-channel designs to help minimize the required board space. The [OPA855](#) device is an 8-GHz bipolar input amplifier that can also be used as a TIA that is available in a pin-to-pin compatible package to the OPA858 device. A more integrated TIA like the [LMH34400](#) provides advantages to TDC based systems with features like ambient light cancellation.

The receive path in this system also employs comparators like TI's [TLV3501](#) or [TLV3801](#) devices to receive the output of the TIA and drive the stop input of the TDC. The TLV3501 is well suited for this part of the circuit since it features a fast rise time of only 1.5 ns and a short delay of only 4.5 ns.

This TDC-based architecture is very good when low cost and low power consumption are desired and only a simple distance measurement is required. For more information about the TDC-based architecture, see the [TIDA-060025](#) reference design and the [Time of](#)

Flight & LIDAR - Optical Front End Reference Design video.

An ADC-based ToF LIDAR system employs a high-speed analog-to-digital converter like TI's [ADC34J45](#) 14-bit 160 MSPS ADC to convert the reflected waveform to a digital signal that can be processed and analyzed. These systems usually use a digital signal processor (DSP) or a field programmable gate array (FPGA) to process the waveform information received via the ADC. These ADC-based systems can usually determine object distance and additional properties about the object like reflectivity. [Figure 3](#) illustrates a block diagram of an ADC-based optical ToF of system.

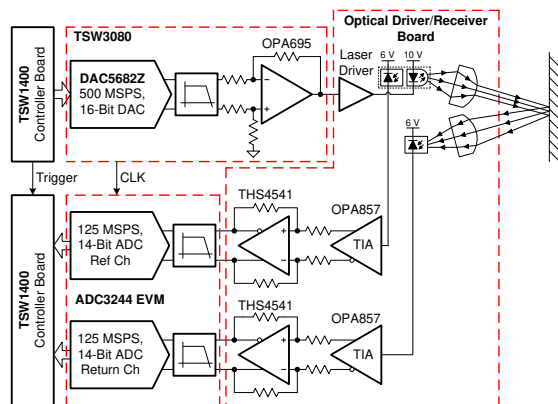

Figure 3. ADC-Based Optical ToF System Diagram

The receive path in this system also requires a TIA to convert the current output of the photodiode into a voltage. In this system a TI [OPA857](#) TIA with integrated selectable gain options is used. The OPA857 device features selectable transimpedance gain options of 5 kΩ or 20 kΩ to allow for flexibility in the system design. The OPA857 is also available in a 3 mm x 3 mm, 8-pin package and in bare die form ([OPA857-DIE](#)) to enable direct wire bonding between the photodiode and the TIA. Direct wire bonding with the OPA857-DIE can significantly reduce parasitic capacitance and inductance between the photodiode and the TIA. The bare die option can also enable smaller designs and more efficient connections between the photodiode and the TIA.

The ADC-based system also uses the [THS4541](#) fully differential amplifier (FDA) to drive the differential inputs of the [ADC34J45](#) high-speed ADC. After the information is digitized, it is processed and analyzed by an FPGA on the TSW1400 controller board. The system then determines object distance information that is displayed on a PC-based application. For more information about the ADC-based architecture, see the [TIDA-01187](#) reference design and the [LiDAR Pulsed Time-of-Flight Reference Design Overview \(TIDA-01187\)](#) video.

Texas Instruments also offers the single-channel [LMH32401](#) and quad-channel [LMH32404](#) state-of-the-art devices that integrates several features for optical ToF receive circuits. [Figure 4](#) illustrates the [LMH32401](#) block diagram.

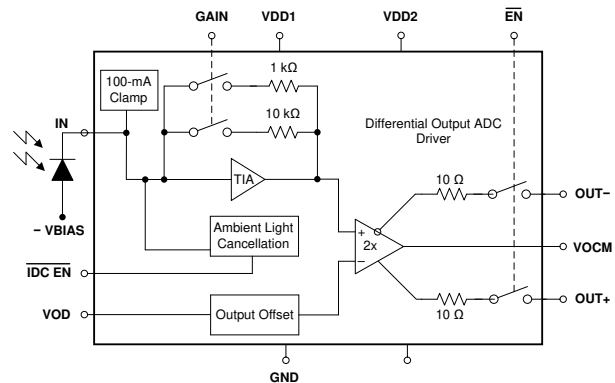

Figure 4. LMH32401 Simplified Block Diagram

The LMH32401 device is a programmable-gain, single-ended input to differential-output transimpedance amplifier. The device can be configured with a transimpedance gain of either 2 kΩ or 20 kΩ and features an integrated single-ended to differential-output amplifier that provides up to 1.5 VPP of output swing making it ideal for driving a high-speed ADC. The LMH32401 also features an integrated 100-mA current clamp that protects the amplifier and allows it to recover rapidly from an overloaded input condition that can occur in optical distance measurement systems. The amplifier also features an integrated ambient light cancellation circuit. The Differential Output Offset Voltage (VOD) input pin of the device can be used to set the differential output between the OUT- and OUT+ pins of the device. This is extremely useful in maximizing the dynamic range of ADCs like the 1.6 GSPS [ADC12QJ1600](#) in optical front ends. The VOD pin voltage allows the OUT- signal to be level-shifted above Output Common Mode Voltage (VOCM) and OUT+ to be level-shifted below VOCM to maximize the output swing capabilities of the amplifier. For more information about optimizing dynamic range of analog front ends, see the [Analog Design Journal](#).

Optical ToF LIDAR systems are used in a wide variety of products and receive paths can be architected using either TDCs or ADCs. TI offers many ICs including TIAs, FDAs, TDCs and ADCs for use in these systems. For additional information about optical systems, see [An Introduction to Automotive LiDAR White Paper](#).

IMPORTANT NOTICE AND DISCLAIMER

TI PROVIDES TECHNICAL AND RELIABILITY DATA (INCLUDING DATA SHEETS), DESIGN RESOURCES (INCLUDING REFERENCE DESIGNS), APPLICATION OR OTHER DESIGN ADVICE, WEB TOOLS, SAFETY INFORMATION, AND OTHER RESOURCES "AS IS" AND WITH ALL FAULTS, AND DISCLAIMS ALL WARRANTIES, EXPRESS AND IMPLIED, INCLUDING WITHOUT LIMITATION ANY IMPLIED WARRANTIES OF MERCHANTABILITY, FITNESS FOR A PARTICULAR PURPOSE OR NON-INFRINGEMENT OF THIRD PARTY INTELLECTUAL PROPERTY RIGHTS.

These resources are intended for skilled developers designing with TI products. You are solely responsible for (1) selecting the appropriate TI products for your application, (2) designing, validating and testing your application, and (3) ensuring your application meets applicable standards, and any other safety, security, regulatory or other requirements.

These resources are subject to change without notice. TI grants you permission to use these resources only for development of an application that uses the TI products described in the resource. Other reproduction and display of these resources is prohibited. No license is granted to any other TI intellectual property right or to any third party intellectual property right. TI disclaims responsibility for, and you will fully indemnify TI and its representatives against, any claims, damages, costs, losses, and liabilities arising out of your use of these resources.

TI's products are provided subject to [TI's Terms of Sale](#) or other applicable terms available either on ti.com or provided in conjunction with such TI products. TI's provision of these resources does not expand or otherwise alter TI's applicable warranties or warranty disclaimers for TI products.

TI objects to and rejects any additional or different terms you may have proposed.

Mailing Address: Texas Instruments, Post Office Box 655303, Dallas, Texas 75265
Copyright © 2022, Texas Instruments Incorporated