

TPS7A78 120-mA, Smart AC/DC Linear Voltage Regulator

1 Features

- Non-isolated power solution for $\geq 18 V_{AC RMS}$:
 - Up to 75% efficiency
 - Standby power consumption: 15 mW (typical)
 - Line-voltage, cap-drop capacitor as small as 1/4th the size of linear solutions
- Available in fixed output voltages:
 - 1.3 V to 5 V (50-mV steps)
- Power-fail detection
- Power-good indication
- 1% typical accuracy
- Package:
 - 5-mm x 6.5-mm HTSSOP-14 (PWP)

2 Applications

- Key panels
- Garage door systems
- Small home appliances
- Electricity meters
- Smoke and heat detectors
- Thermostats

3 Description

The TPS7A78 improves the overall efficiency and standby-power in power-supplies in an easy-to-use, non-magnetic approach to AC/DC conversion. The TPS7A78 uses a capacitor-drop architecture to lower the AC source voltage before actively clamping the rectified voltage. The device then regulates this rectified voltage down to the application-specific operating voltage. The unique architecture of the device allows the standby power to be reduced to just a few 10s of milliwatts. The TPS7A78 switched-capacitor stage reduces power losses by stepping down the rectified input voltage by a factor of four and increasing the output-to-input current by the same ratio, as given by $P_{IN} \cong P_{OUT}$ and $V_{IN} \cong V_{OUT} \times 4$. Compared to a traditional capacitor-drop (cap-drop) stage, this step down reduces input current, thus minimizing the value of the capacitance needed.

Electricity-metering applications, where the power supply must be reliable and magnetic tamper-proof, benefits from using the TPS7A78 because this device does not require external magnetics. This feature makes complying with IEC 61000-4-8 easier while minimizing magnetic shielding cost.

Additionally, the TPS7A78 also comes with a user-programmable, power-fail detection threshold that can provide an early alert to power failures and enable shutdown before complete power loss. The power-good indicator (PG) is also provided for sequencing or resetting a microcontroller.

The TPS7A78 is available in a 14-pin HTSSOP (PWP) package.

Device Information⁽¹⁾

PART NUMBER	PACKAGE	BODY SIZE (NOM)
TPS7A78	HTSSOP (14)	5.00 mm x 6.50 mm

(1) For all available packages, see the orderable addendum at the end of the data sheet.

Typical Schematic Half-Bridge Configuration

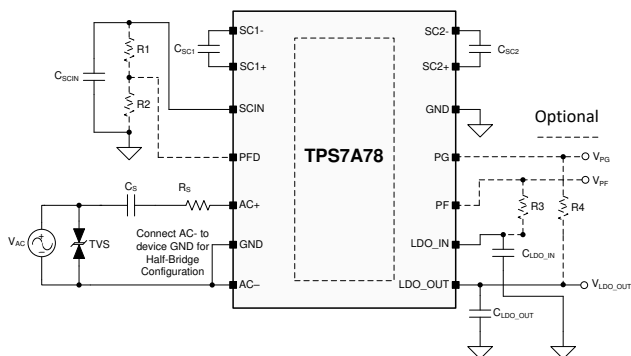

Typical Schematic Full-Bridge Configuration

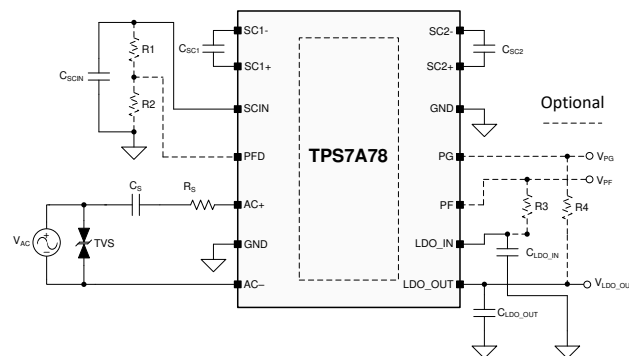

Table of Contents

1 Features	1	7.4 Device Functional Modes.....	14
2 Applications	1	8 Application and Implementation	15
3 Description	1	8.1 Application Information.....	15
4 Revision History	2	8.2 Typical Application	23
5 Pin Configuration and Functions	3	9 Power Supply Recommendations	29
6 Specifications	4	10 Layout	29
6.1 Absolute Maximum Ratings	4	10.1 Layout Guidelines	29
6.2 ESD Ratings.....	4	10.2 Layout Example	29
6.3 Recommended Operating Conditions.....	5	11 Device and Documentation Support	30
6.4 Thermal Information	5	11.1 Device Support.....	30
6.5 Electrical Characteristics.....	6	11.2 Documentation Support	30
6.6 Timing Requirements	6	11.3 Receiving Notification of Documentation Updates	30
6.7 Typical Characteristics	7	11.4 Community Resources.....	30
7 Detailed Description	10	11.5 Trademarks	30
7.1 Overview	10	11.6 Electrostatic Discharge Caution.....	31
7.2 Functional Block Diagram	10	11.7 Glossary	31
7.3 Feature Description	11	12 Mechanical, Packaging, and Orderable Information	31

4 Revision History

NOTE: Page numbers for previous revisions may differ from page numbers in the current version.

Changes from Original (March 2019) to Revision A

Page

• Changed device status from APL to production data	1
---	----------

5 Pin Configuration and Functions

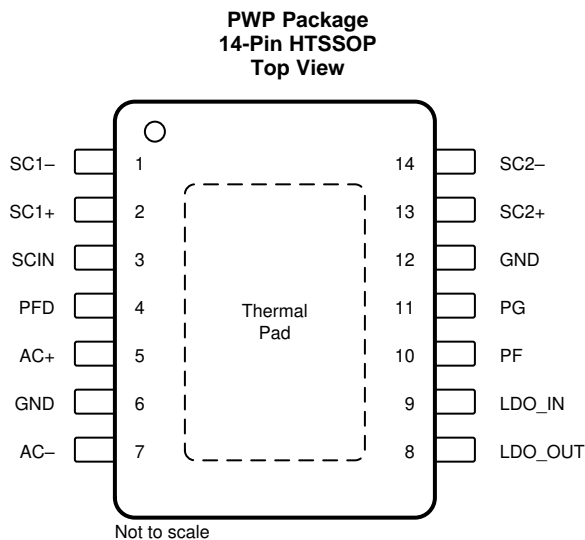

Pin Functions

PIN		TYPE	DESCRIPTION
NO.	NAME		
1	SC1-	—	Negative terminal of the switched-capacitor, voltage-reduction stage pin. Connect a minimum 1- μ F, X5R (or better) dielectric, 16-V-rated capacitor between this pin and the SC1+ pin. Place the capacitor as close to the device as possible; see the Recommended Operating Conditions table for details.
2	SC1+	—	Positive terminal of the switched-capacitor, voltage-reduction stage pin. Connect a minimum 1- μ F, X5R (or better) dielectric, 16-V-rated capacitor between this pin and the SC1- pin. Place the capacitor as close to the device as possible; see the Recommended Operating Conditions table for details.
3	SCIN	—	Rectified DC-voltage pin. Place the capacitor as close to the device as possible; see the Device Functional Modes section for the dual-input power-supply capability and the Calculating the Bulk Capacitor section for the proper capacitor calculation.
4	PFD	Input	Power-failure detect pin. An analog voltage input compares the reference voltage to a resistor-divided V_{SCIN} voltage to detect a V_{AC} power-failure; see the Recommended Operating Conditions table and the Calculating the PFD Pin Resistor Dividers for Power-Fail Detection section for details.
5	AC+	Power	AC-supply line or neutral input to the device after the capacitive-drop (cap-drop) capacitor and surge resistor. Either this pin or the AC- pin must have the cap-drop capacitor and surge resistor in series with the line. See the Full-Bridge (FB) and Half-Bridge (HB) Configurations section for details.
6	GND	Ground	Ground pin. All device ground pins must be referenced to the same ground. Connect this pin to the thermal pad at the bottom of the device; see the Layout section for details.
7	AC-	Power	AC-supply line or neutral input to the device pin after the cap-drop capacitor and surge resistor. Either this pin or the AC+ pin must have the cap-drop capacitor and surge resistor in series with the line. See the Full-Bridge (FB) and Half-Bridge (HB) Configurations section for details.
8	LDO_OUT	Output	Regulated DC output pin. Connect a minimum 0.68- μ F, X5R (or better) dielectric capacitor between this pin and the device GND pins. Place the capacitor as close to the device as possible; see the Recommended Operating Conditions table for the maximum capacitor value.
9	LDO_IN	—	Charge-pump output pin. Connect a minimum 0.68- μ F, X5R (or better) dielectric capacitor between this pin and the device GND pins. This pin is internally driven and must not be driven externally. For optimal performance, connect a capacitor that is 10x the value of C_{LDO_OUT} placed as close to the device as possible. See the Recommended Operating Conditions table for the maximum capacitor value.
10	PF	Output	Power-fail indicator pin. An open-drain indicator signal indicates if the V_{AC} supply has failed. Pullup this pin through an external resistor to V_{LDO_IN} or to a DC-rail that shares the same GND as the device. The PF pin goes low when V_{PFD} is less than the $V_{IT(PFD,FALLING)}$ threshold, as specified in the Electrical Characteristics table. See the Recommended Operating Conditions table for proper selection of the pullup resistor.

Pin Functions (continued)

PIN		TYPE	DESCRIPTION
NO.	NAME		
11	PG	Output	Power-good indication pin. An open-drain indicator signal indicates if the V_{LDO_OUT} surpassed the $V_{IT(PG,RISING)}$ threshold, as specified in the Electrical Characteristics table. Pullup this pin through an external resistor to V_{LDO_OUT} or to a DC rail that shares the same GND as the device. See the Recommended Operating Conditions table for proper selection of the pullup resistor.
12	GND	Ground	Ground pin. All device ground pins must be referenced to the same ground. Connect this pin to the thermal pad at the bottom of the device; see the Layout section for details.
13	SC2+	—	Positive terminal of the switched-capacitor, voltage-reduction stage pin. Connect a minimum 1- μ F, X5R (or a better) dielectric, 10-V-rated capacitor between this pin and the SC2– pin. Place the capacitor as close to the device as possible; see the Recommended Operating Conditions table for details.
14	SC2–	—	Negative terminal of the switched-capacitor, voltage-reduction stage pin. Connect a minimum 1- μ F, X5R (or a better) dielectric, 10-V-rated capacitor between this pin and the SC2+ pin. Place the capacitor as close to the device as possible; see the Recommended Operating Conditions table for details.
Thermal pad		—	Exposed pad of the package. Connect this pad to device ground pins. Connect the thermal pad to a large-area ground plane for best thermal performance.

6 Specifications

6.1 Absolute Maximum Ratings

 over operating free-air temperature range (unless otherwise noted)⁽¹⁾⁽²⁾

		MIN	MAX	UNIT
Voltage	AC+, AC– (V_{AC} supply mode only)	–1.5	30	V
	SCIN (V_{AC} supply mode only, internally driven)	–1.5	30	
	SCIN (DC supply mode only, voltage directly applied on SCIN pin)	–0.3	24	
	LDO_OUT	–0.3	5.5	
	PF, PG	–0.3	6	
	PFD	–0.3	3	
Current	LDO_OUT pin reverse current ⁽³⁾		6	mA
	Maximum output	Internally limited		
	I_{PF} , I_{PG}		5	
Temperature	Storage, T_{STG}	–65	150	°C

- (1) Stresses beyond those listed under *Absolute Maximum Rating* may cause permanent damage to the device. These are stress ratings only, which do not imply functional operation of the device at these or any other conditions beyond those indicated under *Recommended Operating Condition*. Exposure to absolute-maximum-rated conditions for extended periods may affect device reliability.
- (2) All voltages are with respect to the device GND pins (not Earth GND); see the [Full Bridge \(FB\) and Half Bridge \(HB\) Configurations](#) section for details.
- (3) Exceeding the maximum reverse current into the LDO_OUT pin can cause damage to the device; see the [Reverse Current](#) section for details.

6.2 ESD Ratings

		VALUE	UNIT
$V_{(ESD)}$	Electrostatic discharge	Human body model (HBM), per ANSI/ESDA/JEDEC JS-001, all pins ⁽¹⁾	±2000
		Charged device model (CDM), per JEDEC specification JESD22-C101, all pins ⁽²⁾	±1000

- (1) JEDEC document JEP155 states that 500-V HBM allows safe manufacturing with a standard ESD control process.
- (2) JEDEC document JEP157 states that 250-V CDM allows safe manufacturing with a standard ESD control process.

6.3 Recommended Operating Conditions

over operating free-air temperature range (unless otherwise noted)⁽¹⁾

		MIN	NOM	MAX	UNIT
V _{AC} ⁽²⁾	Connected via C _S ⁽³⁾ and R _S ⁽³⁾⁽⁴⁾ on either AC+ or AC–	18 ⁽⁵⁾			V _{RMS}
f _{AC}	Line frequency		50	20,000	Hz
I _{SURGE}	Peak transient current into or out of either the AC+ or AC– pins (during hot plug for ≤ 100 μs)			2.5	A
I _{SHUNT}	AC current during shunt event on either AC+ or AC– pins			200	mA _{RMS}
V _{SCIN}	DC supply mode, voltage applied to the SCIN pin for devices with V _{LDO_OUT} ≤ 3.4 V	17 ⁽⁶⁾		23	V
C _{SCIN}	Bulk capacitor for V _{AC} supply mode	22			μF
C _{SCIN}	Bulk capacitor for DC-supply mode	1.0			
C _{SC1}	Switched-capacitor stage 1	1		4.7 ⁽⁷⁾	μF
C _{SC2}	Switched-capacitor stage 2	1		4.7 ⁽⁷⁾	μF
C _{LDO_IN}	LDO_IN capacitor	0.68	10	1000	μF
C _{LDO_OUT}	LDO_OUT capacitor	0.68	1	100	μF
R ₁	PFD top resistor divider	0		200	kΩ
R ₃ & R ₄	Power-good and power-fail pullup resistors	10		100	kΩ
I _{OUT}	Output current	0		120	mA
T _J	Operating junction temperature	–40		125	°C

- (1) All voltages are with respect to the device GND pins (not Earth GND); see the [Full Bridge \(FB\) and Half Bridge \(HB\) Configurations](#) section for details.
- (2) Theoretically there is no upper limit to the V_{AC} supply voltage because this voltage is dropped across the C_S capacitor; see the [Calculating the Cap-Drop Capacitor](#) section for details.
- (3) The voltage ratings for the cap-drop capacitor C_S and the surge resistor R_S must be able to handle the peak V_{AC} supply voltage; see the [Typical Application](#) section for details.
- (4) The surge resistor R_S is required to limit the inrush current into or out off either AC+ or AC– pins during hot-plug or surge current events; see the [Calculating the Surge Resistor](#) section for details.
- (5) Only available for devices with ≤ 3.3-V output voltage options.
- (6) DC-supply mode is also available for 3.6-V devices but with a minimum required V_{SCIN} supply voltage of 18 V.
- (7) A 16 V or higher voltage rating is recommended for the C_{SC1} capacitor, and a 10 V or higher voltage rating is recommended for the C_{SC2} capacitor.

6.4 Thermal Information

THERMAL METRIC ⁽¹⁾⁽²⁾		TPS7A78		UNIT
		PWP (TSSOP)		
		14 PINS		
R _{θJA}	Junction-to-ambient thermal resistance	48.0		°C/W
R _{θJC(top)}	Junction-to-case (top) thermal resistance	44.0		°C/W
R _{θJB}	Junction-to-board thermal resistance	24.2		°C/W
Ψ _{JT}	Junction-to-top characterization parameter	1.6		°C/W
Ψ _{JB}	Junction-to-board characterization parameter	24.1		°C/W
R _{θJC(bot)}	Junction-to-case (bottom) thermal resistance	7.2		°C/W

- (1) For more information about traditional and new thermal metrics, see the [Semiconductor and IC Package Thermal Metrics](#) application report.
- (2) Thermal metrics were modeled on a JEDEC Hi-K board in order to provide a standardized layout and measurement technique for comparison purposes. The [An empirical analysis of the impact of board layout on LDO thermal performance](#) application report goes into detail on how board layout impacts the thermal performance of linear regulators.

6.5 Electrical Characteristics

$V_{SCIN}^{(1)} = 4 (V_{LDO_OUT(nom)} + 0.6 V) + 1 V$ or 17 V (whichever is greater), $C_{SCIN} = 10 \mu F$, $C_{S1} = 1.0 \mu F$, $C_{S2} = 2.2 \mu F$, $C_{LDO_IN} = 10 \mu F$, $C_{LDO_OUT} = 1.0 \mu F$, and $I_{OUT} = 1 mA$ (unless otherwise noted); typical values are at $T_J = 25^\circ C^{(2)}$

PARAMETER		TEST CONDITIONS	MIN	TYP	MAX	UNIT
V_{UVLO_SCIN}	UVLO_SCIN threshold rising	V_{SCIN} rising, $V_{LDO_OUT(nom)} \leq 3.4 V$	17			V
$V_{UVLO_LDO_IN}$	UVLO_LDO_IN threshold rising	V_{SCIN} rising	3.9			V
	UVLO_LDO_IN threshold falling	V_{SCIN} falling			3.5	V
$\Delta V_{LDO_OUT(\Delta I_{OUT})}$	Load regulation	$0 mA \leq I_{OUT} \leq 120 mA$			0.21	mV/mA
V_{LDO_OUT}	Output voltage accuracy	$V_{SCIN}^{(1)(3)} = 4 (V_{LDO_OUT(nom)} + 0.6 V) + 3 V$, $0 mA \leq I_{OUT} \leq 120 mA$	-2	1	2	%
I_{CL}	Output current limit	$V_{LDO_OUT} = 0.9 \times V_{LDO_OUT(nom)}$	145	215	300	mA
I_{DD_SCIN}	SCIN pin quiescent current	$V_{LDO_OUT(nom)} = 3.3 V$, $I_{OUT} = 0 mA$, no R_3 , R_4		280		μA
V_{Ripple}	Output voltage ripple	$V_{AC} = 120 V$, 60 Hz, FB, $C_S = 1.0 \mu F$, $C_{SCIN} = 180 \mu F$, $V_{LDO_OUT(nom)} = 5 V$, $I_{OUT} = 10 mA$, scope BW = 10 MHz		3		mV
$V_{IT(PFD,RISING)}$	PFD pin rising threshold	V_{PFD} rising, $R_4 = 100 k\Omega$	1.24		1.42	V
$V_{IT(PFD,FALLING)}$	PFD pin falling threshold	V_{PFD} falling, $R_4 = 100 k\Omega$	1.17		1.25	
$V_{HYS(PFD)}$	PFD pin hysteresis			110		mV
$V_{IT(PG,RISING)}$	PG pin rising threshold	$R_3 = 100 k\Omega$, V_{SCIN} rising	90.16	92	93.84	% V_{LDO_OUT}
$V_{IT(PG,FALLING)}$	PG pin falling threshold	$R_3 = 100 k\Omega$	88.5	90	91.5	
$V_{HYS(PG)}$	PG pin hysteresis			2		
$V_{OL(PF),(PG)}$	PF and PG pins low-level output voltage	$I_{PF,PG} = 500 \mu A$			0.2	V
$I_{LKG(PF),(PG)}$	PF and PG pins open-drain leakage current	$V_{PF,PG} = 5 V$			50	nA
$T_{SD(Shutdown)}$	Thermal shutdown temperature	Shutdown, temperature increasing		162		$^\circ C$
$T_{SD(Reset)}$	Thermal shutdown reset temperature	Reset, temperature decreasing		135		

(1) For $V_{LDO_OUT} > 4.4 V$, V_{SCIN} is limited to 24 V for testing purposes only.

(2) Electrical characteristic data tested in DC supply mode equivalent to V_{SCIN} voltage under AC supply mode.

(3) $V_{SCIN} \geq 19 V$.

6.6 Timing Requirements

		MIN	NOM	MAX	UNIT
$t_{PF(HL)}$	PF pin going from high to low		1		μs
$t_{PG(LH)}$	PG pin going from low to high		1		μs
f_{SC}	Switched capacitor stage operating frequency		200		kHz

6.7 Typical Characteristics

at operating temperature $T_J = 25^\circ\text{C}$, V_{AC} supply = 120 V_{RMS} per 60 Hz, full-bridge (FB) bridge configuration, $C_S = 1.0 \mu\text{F}$, $C_{SCIN} = 220 \mu\text{F}$, $C_{SC1} = 1.0 \mu\text{F}$, $C_{SC2} = 2.2 \mu\text{F}$, $C_{LDO_IN} = 10 \mu\text{F}$, $C_{LDO_OUT} = 1.0 \mu\text{F}$, and $I_{OUT} = 1 \text{ mA}$ (unless otherwise noted)

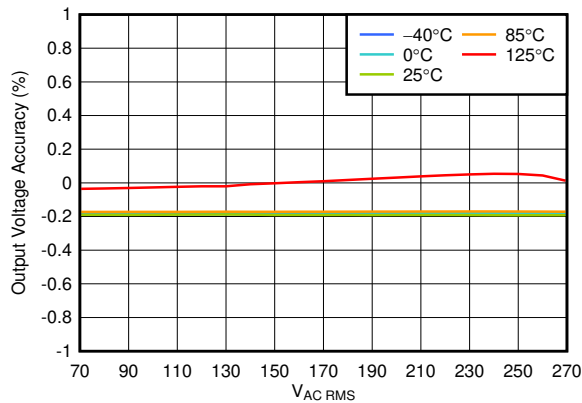

Figure 1. V_{LDO_OUT} Accuracy vs V_{AC} Supply

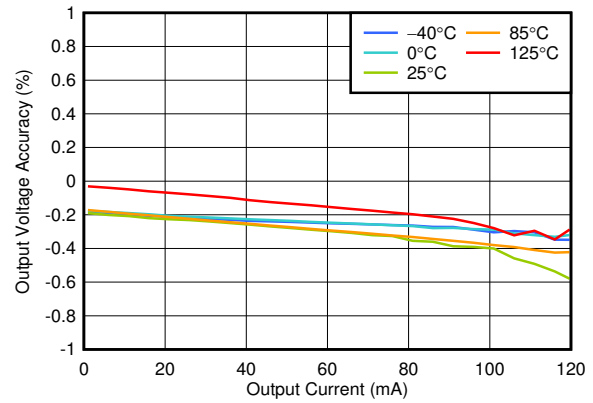

Figure 2. V_{LDO_OUT} Accuracy vs I_{OUT}

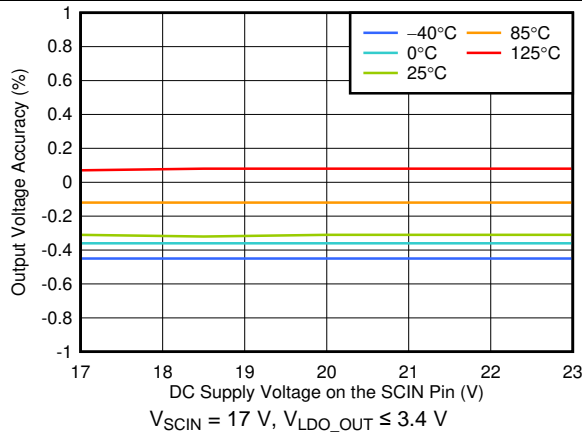

Figure 3. V_{LDO_OUT} Accuracy vs DC Supply on the SCIN Pin

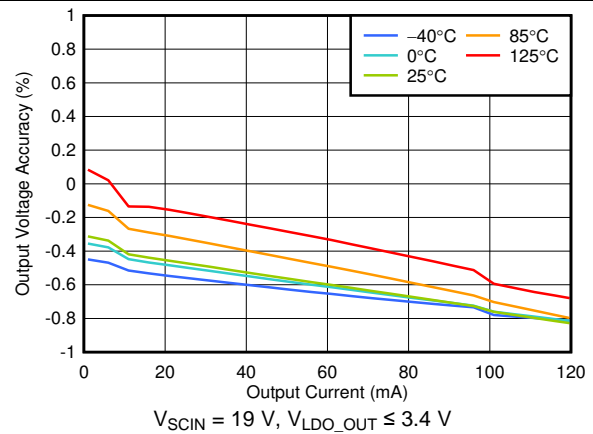

Figure 4. V_{LDO_OUT} Accuracy vs I_{OUT} DC Supply on the SCIN Pin

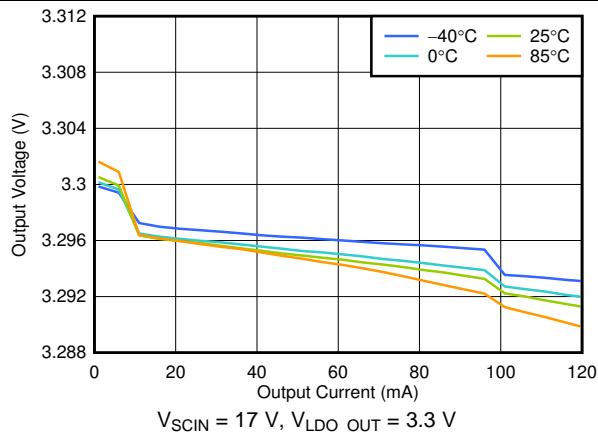

Figure 5. V_{LDO_OUT} vs I_{OUT} DC Supply on the SCIN Pin

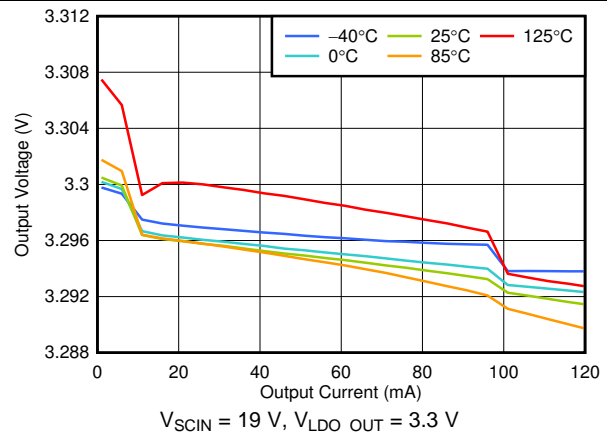

Figure 6. V_{LDO_OUT} vs I_{OUT} DC Supply on the SCIN Pin

Typical Characteristics (continued)

at operating temperature $T_J = 25^\circ\text{C}$, V_{AC} supply = 120 V_{RMS} per 60 Hz, full-bridge (FB) bridge configuration, $C_S = 1.0 \mu\text{F}$, $C_{SCIN} = 220 \mu\text{F}$, $C_{SC1} = 1.0 \mu\text{F}$, $C_{SC2} = 2.2 \mu\text{F}$, $C_{LDO_IN} = 10 \mu\text{F}$, $C_{LDO_OUT} = 1.0 \mu\text{F}$, and $I_{OUT} = 1 \text{ mA}$ (unless otherwise noted)

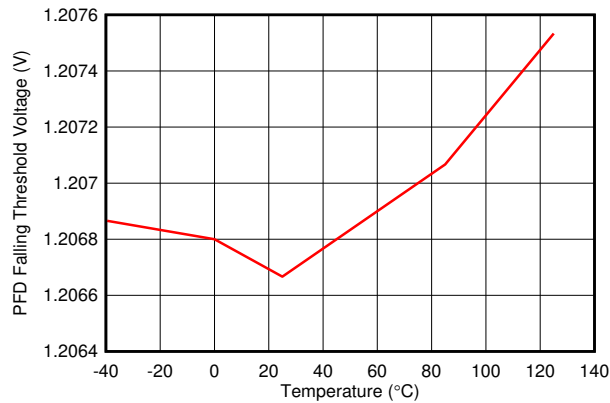

Figure 7. $V_{IT(PFD,FALLING)}$ Threshold vs Temperature

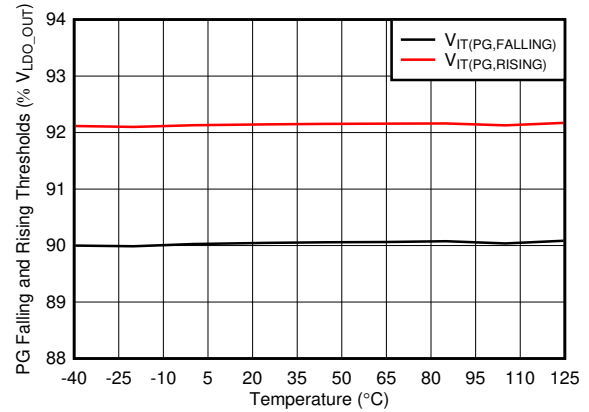

Figure 8. $V_{IT(PG,FALLING)}$ and $V_{IT(PG,RISING)}$ Thresholds vs Temperature

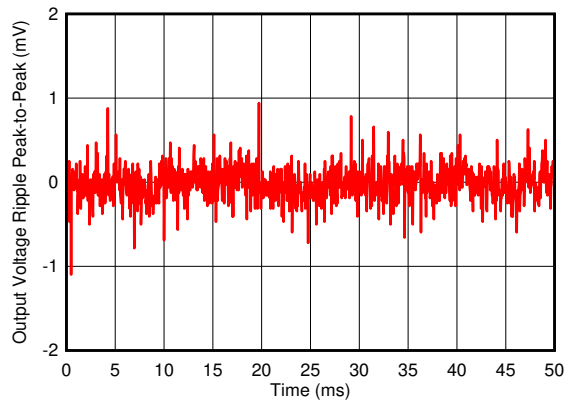

Figure 9. V_{LDO_OUT} Ripple for FB Configuration

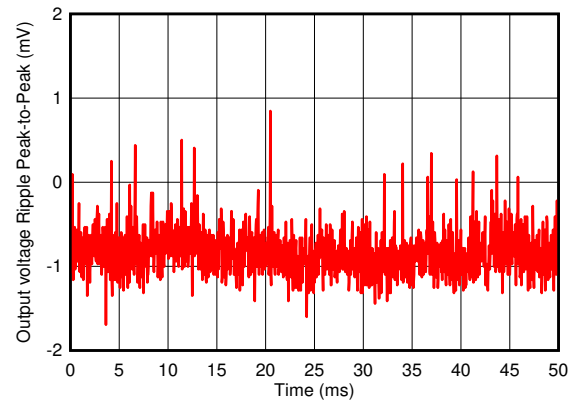
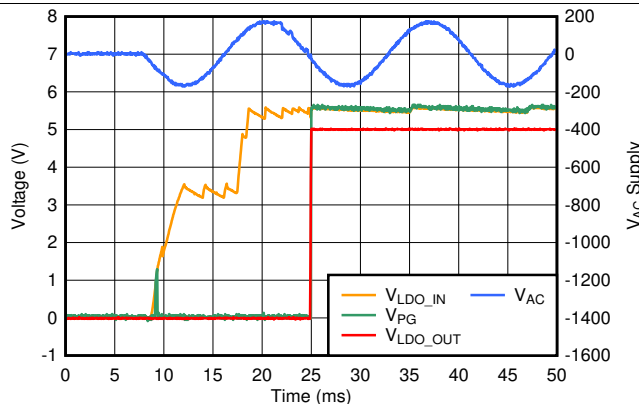
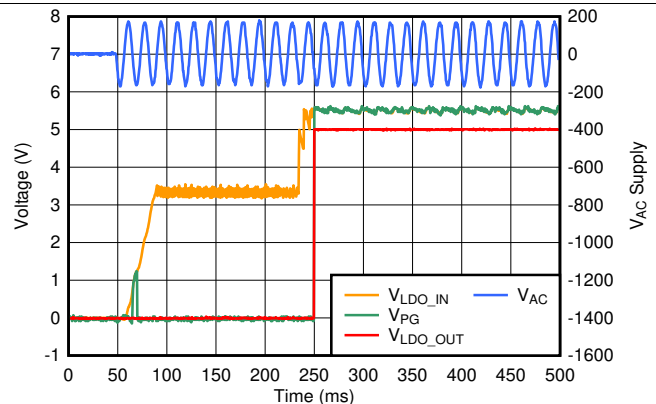

Figure 10. V_{LDO_OUT} Ripple for FB Configuration



$C_S = 2.2 \mu\text{F}$, $C_{SCIN} = 22 \mu\text{F}$, $C_{LDO_IN} = 1.0 \mu\text{F}$, $I_{OUT} = 10 \text{ mA}$

Figure 11. Fast Startup With Larger Than the Required Cap-Drop Capacitor for 10-mA I_{OUT}



$C_S = 100 \text{ nF}$, $C_{SCIN} = 22 \mu\text{F}$, $C_{LDO_IN} = 1.0 \mu\text{F}$, $I_{OUT} = 10 \text{ mA}$

Figure 12. Slow Startup With the Minimum Required Cap-Drop Capacitor for 10-mA I_{OUT}

Typical Characteristics (continued)

at operating temperature $T_J = 25^\circ\text{C}$, V_{AC} supply = 120 V_{RMS} per 60 Hz, full-bridge (FB) bridge configuration, $C_S = 1.0 \mu\text{F}$, $C_{SCIN} = 220 \mu\text{F}$, $C_{SC1} = 1.0 \mu\text{F}$, $C_{SC2} = 2.2 \mu\text{F}$, $C_{LDO_IN} = 10 \mu\text{F}$, $C_{LDO_OUT} = 1.0 \mu\text{F}$, and $I_{OUT} = 1 \text{ mA}$ (unless otherwise noted)

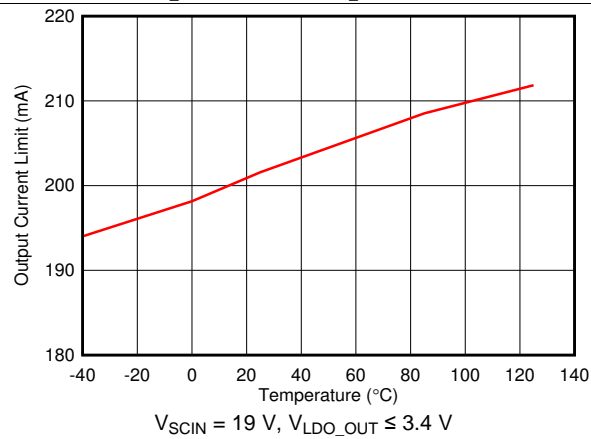

Figure 13. I_{OUT} Current Limit

7 Detailed Description

7.1 Overview

The TPS7A78 features an internally controlled, active bridge rectifier that can be configured either as full bridge (FB) or a half bridge (HB), a 4:1 switched-capacitor stage (charge pump), an internally controlled low-dropout (LDO) linear-voltage regulator, as well as current-limit, thermal-shutdown, programmable power-fail detection, and power-good detection.

The TPS7A78 is a non-isolated, smart linear-voltage regulator that uses an external high-voltage, capacitor-drop (cap-drop) capacitor (C_S) and an internally controlled, active bridge-rectifier to create a regulated DC output voltage. The device incorporates a switched-capacitor charge pump stage that transforms the voltage and current characteristics of the rectifier stage to the voltage and current needs of the LDO stage, providing a 4-times reduction in input power for a given load power. This feature also reduces the size of the required C_S by a factor of 4. The external surge resistor R_S is used to limit the inrush-current to the device. Unlike typical AC-to-DC power solutions, the TPS7A78 does not require external magnetic components, thus making the device an excellent choice for electricity-metering applications by improving tamper resistance. This unique design allows the TPS7A78 to reduce standby power to approximately 15 mW for light-load applications while maintaining high efficiency.

For applications with output voltages of 3.6 V or less, the TPS7A78 can be powered from a DC supply connected directly to the SCIN pin. This supply mode can provide DC-only operation or DC-powered backup in case of AC supply failure. When a DC supply is used to power the device, the internally controlled dropout voltage regulation is affected as explained in the [Dropout Voltage Regulation](#) section. The AC+ and AC– pins must be grounded when only a DC power source is used.

7.2 Functional Block Diagram

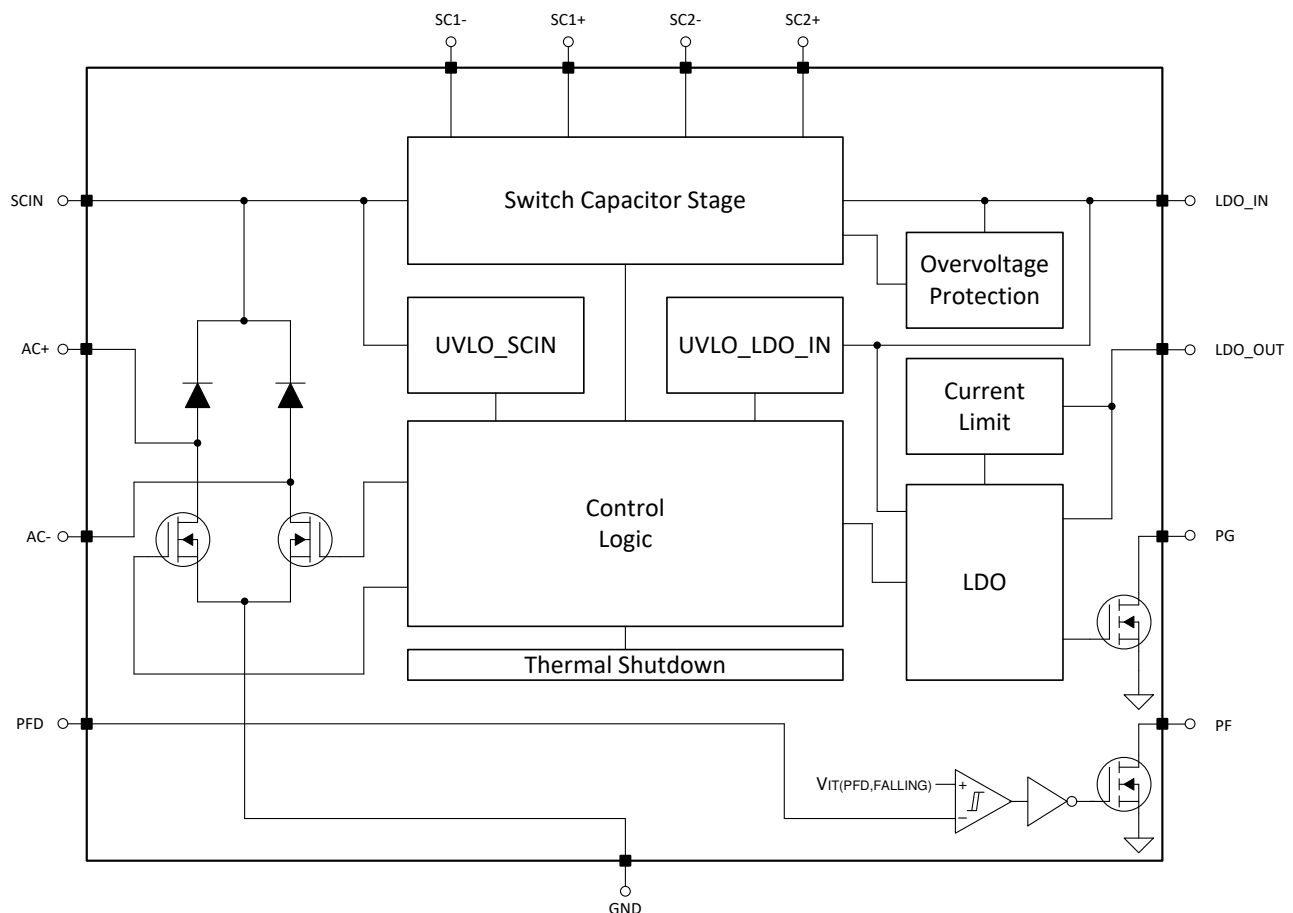

7.3 Feature Description

7.3.1 Active Bridge Control

The TPS7A78 has an internally controlled, actively clamped, full-bridge rectifier between the AC+ and AC– pins that requires one of these pins to be connected in series with the high-voltage capacitor C_S and the surge resistor R_S . The active clamp for the bridge is designed to stabilize the rectified DC voltage at the SCIN pin to optimize performance given the LDO output voltage. The clamp circulates any excess AC charging current from the cap-drop capacitor C_S and surge resistor R_S through the AC+ or the AC– pins to the GND pins when the SCIN pin voltage surpasses its UVLO_SCIN rising threshold during startup. The clamp maintains the SCIN pin voltage higher than this threshold to support the targeted output voltage. This excess AC charging current is also referred to as the shunt current, I_{SHUNT} ; see the [Standby Power and Output Efficiency](#) section for details on the shunt current.

A DC supply can also be used to provide power directly to the SCIN pin, which completely bypasses the bridge active-clamp circuit; see [Table 1](#) for details on the DC supply mode.

7.3.2 Full-Bridge (FB) and Half-Bridge (HB) Configurations

The TPS7A78 can be configured to operate either in full-bridge (FB) or half-bridge (HB) configurations. HB configuration ties the AC input pin without the series C_S and R_S components to the device GND pins. See [Figure 14](#) and [Figure 15](#) for the HB and FB configurations.

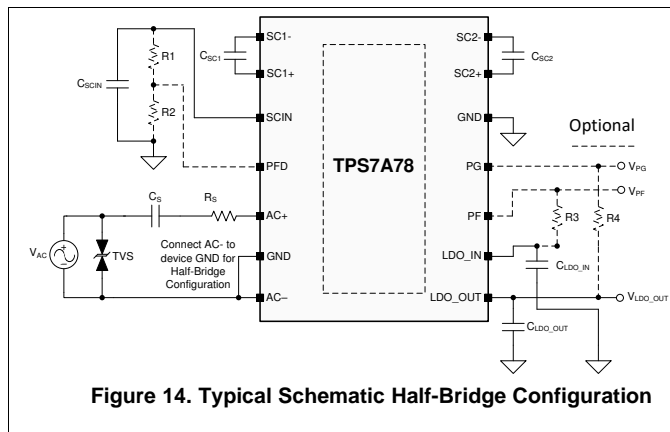

Figure 14. Typical Schematic Half-Bridge Configuration

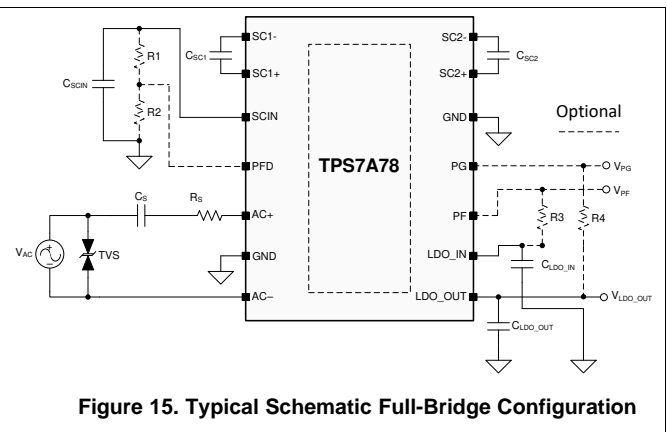

Figure 15. Typical Schematic Full-Bridge Configuration

NOTE

When FB configuration is used, do not tie the device GNDs to earth GND neither schematically nor accidentally via an earth-grounded oscilloscope or measurement equipment because the device GNDs and earth GND are at different voltage potentials. Doing so can cause damage to the device and external equipment. Tying the device GND pins to earth GND when FB configuration is used is only acceptable if a second surge resistor R_S is used on the AC input pin side without the series C_S and first R_S , as illustrated in [Figure 16](#) with floating device GND pins and [Figure 17](#) with non-floating (earth grounded) device GND pins.

Feature Description (continued)

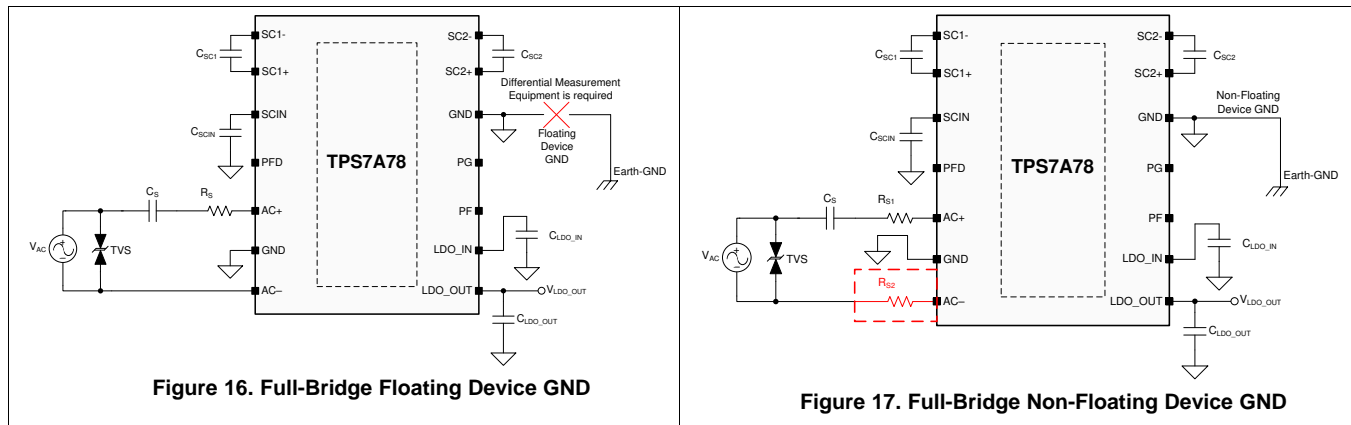

Figure 16. Full-Bridge Floating Device GND

Figure 17. Full-Bridge Non-Floating Device GND

7.3.3 4:1 Switched-Capacitor Voltage Reduction

The TPS7A78 uses a switched-capacitor charge pump to reduce the rectified DC voltage at the SCIN pin by four times, providing the LDO block with an input voltage above its dropout voltage that is then regulated to the target output voltage. The DC voltage at the SCIN pin can be provided either by the active clamp for the bridge rectifying the input V_{AC} supply or by a direct DC supply connection to the SCIN pin.

7.3.4 Undervoltage Lockout Circuits (V_{UVLO_SCIN}) and ($V_{UVLO_LDO_IN}$)

The TPS7A78 incorporates two undervoltage lockout (UVLO) circuits; the UVLO_SCIN circuit and the UVLO_LDO_IN circuit. UVLO_SCIN is used to make sure that the active clamp for the bridge has charged the C_{SCIN} capacitor to a voltage level that surpasses the UVLO_SCIN rising threshold to start the switched-capacitor stage. The UVLO_SCIN rising threshold voltage is a function of the LDO output voltage, $V_{LDO_OUT(nom)}$, as indicated in the [Electrical Characteristics](#) table.

The UVLO_LDO_IN circuit is used to ensure that the switched-capacitor stage has charged the C_{LDO_IN} capacitor to a voltage level that surpasses the UVLO_LDO_IN rising threshold to enable the LDO circuit to begin regulation at the specified LDO output voltage. See the [Startup Behavior](#) section for details.

NOTE

The LDO_IN pin must not be driven externally and must not be used as a supply rail to an external load.

7.3.5 Dropout Voltage Regulation

This LDO functional block follows the conventional definition of dropout voltage (V_{DO}) between V_{LDO_IN} and V_{LDO_OUT} . However, the supply mode can have an effect on the dropout voltage.

When the AC input is used as the supply, a fixed dropout (V_{DO}) of 600 mV (typical) between V_{LDO_IN} and V_{LDO_OUT} is maintained for output voltages between 5.0 V and 3.4 V. For output voltages below 3.4 V, the V_{LDO_IN} voltage is maintained at 4.0 V regardless of the output voltage.

A DC supply via the SCIN pin can only be used for output voltages of 3.6 V or less. Under a load condition approaching maximum output current and at high ambient temperature, the LDO can be driven into dropout; see the [Switched-Capacitor Stage Output Impedance](#) section for details.

7.3.6 Current Limit

The LDO block has an internal current-limit circuit that protects the output during overcurrent events or short-circuit faults. The current-limit circuit limits the output current to (I_{CL}), as specified in the [Electrical Characteristics](#) table.

Feature Description (continued)

When in current limit, the output voltage cannot be regulated and the device heats up because of the increase in power dissipation. When in current limit, the LDO pass transistor dissipates power equal to $V_{DO} \times I_{CL}$, where V_{DO} is equal in the worst case to V_{LDO_IN} . The heat generated when operating at current limit, in conjunction with the ambient temperature, can trigger the internal thermal shutdown. During thermal shutdown, both V_{LDO_OUT} and the switched-capacitor stage are shut down to prevent further heating; see the [Load Transient](#) section for more details.

7.3.7 Programmable Power-Fail Detection

The TPS7A78 can monitor the rectified DC voltage at the SCIN pin to provide the application with an early warning via the power-fail (PF) pin if the main power fails. An external resistor-divider network connected to the VSCIN pin provides the input to the power-fail detect (PFD) analog input pin to monitor for an AC line supply failure. When the AC supply falls below its minimum level programmed by the resistor divider R_1 and R_2 , as illustrated in [Figure 14](#) and in [Figure 15](#), the PF output is pulled low. If this feature is not used, omit R_1 and R_2 and connect PFD and PF pins to the device GND pins reference.

NOTE

The PFD pin can also be used to monitor another DC rail within the application to provide an early warning via the PF pin. However, this DC rail must share the same GND reference with the TPS7A78 GND and the absolute maximum voltage of the PF pin must not be exceeded.

7.3.8 Power-Good (PG) Detection

The power-good (PG) circuit monitors the V_{LDO_OUT} voltage to indicate the status of the LDO output voltage. PG is pulled low until V_{LDO_OUT} reaches its proper regulate voltage level, then PG is released and allowed to be pulled high. If V_{LDO_OUT} falls below the $V_{IT(PG_FALLING)}$ threshold, PG is asserted low to indicate the LDO output voltage is not in regulation. PG pin low assertion can happen during an overcurrent event or a short-circuit fault.

PG can be used to release the reset pin of a microcontroller. The PG pin must be pulled up to a DC rail such as V_{LDO_OUT} .

Use the recommended pullup resistor value specified in the [Electrical Characteristics](#) table for the PG pin. The functionality of the power-good detection pin has no effect on the internal control logic other than to indicate the state of the output voltage. If this function is not used, connect the PG pin to the device GND pins reference.

NOTE

An external DC rail can also be used to pull up the PG pin signal via a pullup resistor only when the external DC rail shares the same reference GND with the TPS7A78 GND and the absolute maximum voltage of the PG pin is not exceeded.

7.3.9 Thermal Shutdown

A thermal shutdown protection circuit is included to disable V_{LDO_OUT} and to stop the switched-capacitor stage from switching when the junction temperature T_J of the pass-transistor rises to $T_{SD(SHUTDOWN)}$. Thermal shutdown hysteresis assures that the device resets, resumes normal operation, and that V_{LDO_OUT} turns back on when T_J falls to $T_{SD(RESET)}$. Based on the thermal time constant of the die and the device startup time, the device output can cycle on and off until power dissipation is reduced and the junction temperature remains below $T_{SD(RESET)}$.

For reliable operation, limit the junction temperature to the maximum listed in the [Recommended Operating Conditions](#) table. Operating above this maximum temperature causes the device to exceed its operational specifications. Although the internal protection circuitry is designed to protect against thermal overload conditions, this circuitry is not intended to replace proper heat sinking. Continuously running the device into thermal shutdown or above the maximum recommended junction temperature reduces long-term reliability.

7.4 Device Functional Modes

The unique features of the TPS7A78, along with its dual-input power-supply capability, enables the device to be used in a vast array applications. [Table 1](#) gives a general overview of the conditions that lead to different modes of operation, given that the requirements in the [Typical Application](#) section are met.

Table 1. Device Functional Mode Comparison

OPERATING MODE	PARAMETER		
	DEVICE POWER-SUPPLY	I _{OUT}	T _J
Normal operation	V _{AC} supply ⁽¹⁾ / DC supply ⁽²⁾	I _{OUT} < I _{CL} used in the Calculating the Cap-Drop Capacitor C_S section	T _J < T _{SD} (Shutdown)
Dropout mode ⁽³⁾	C _S or C _{SCIN} capacitors are not sufficient to support I _{OUT} (V _{AC} supply)	I _{OUT} < I _{CL} used in the Calculating the Cap-Drop Capacitor C_S section	T _J < T _{SD} (Shutdown)
	V _{SCIN} ≤ V _{UVLO_SCIN} rising threshold and V _{LDO_IN} > V _{UVLO_LDO_IN} rising threshold (DC supply) ⁽⁴⁾	I _{OUT} < I _{CL} used in the Calculating the Cap-Drop Capacitor C_S section	T _J < T _{SD} (Shutdown)
Disabled mode ⁽⁵⁾	V _{LDO_IN} < V _{UVLO_LDO_IN} falling threshold (V _{AC} supply)	Not applicable	T _J > T _{SD} (Shutdown)
	V _{LDO_IN} < V _{UVLO_LDO_IN} falling threshold (DC supply)		

- (1) The device can function with the V_{AC} supply down to 18 V_{RMS}; see the [Typical Application](#) section for details.
- (2) The DC supply applied on the SCIN pin must be bounded by the V_{SCIN (MAX)} > V_{SCIN} > V_{UVLO_SCIN} (RISING) threshold as specified in the [Recommended Operating Conditions](#) and [Electrical Characteristics](#) tables.
- (3) The device can be in dropout when powered by V_{AC} or DC supplies; see the [Dropout Voltage Regulation](#) section for details.
- (4) This condition applies after device has started up.
- (5) Any true condition disables the device V_{LDO_OUT} and stops the switched-capacitor stage from switching; see the [Disabled Mode](#) section for details.

7.4.1 Normal Operation

The device is mainly designed to be powered by the AC supply; however, a DC supply can also be used to power the TPS7A78. See the [Active Bridge Control](#) and [Application and Implementation](#) sections for proper operation.

7.4.2 Dropout Mode

During dropout mode and when V_{LDO_OUT} tracks V_{LDO_IN}, the transient performance becomes significantly degraded because the pass-transistor is operating in the ohmic or triode region.

7.4.3 Disabled Mode

There is no disable pin and disable mode simply means that the output, V_{LDO_OUT}, is turned off and the switched capacitor (see the [4:1 Switched-Capacitor Voltage Reduction](#) section) is not switching. However, when V_{SCIN} is less than the V_{UVLO_SCIN} rising threshold and V_{LDO_IN} is greater than the V_{UVLO_LDO_IN} falling threshold, the internal blocks resume normal operation when either the AC or the DC supply is restored.

NOTE

When the device is in disabled mode and powered by an AC supply, the bridge active control (see the [Active Bridge Control](#) section) continues to run until the AC supply powers off.

8 Application and Implementation

NOTE

Information in the following applications sections is not part of the TI component specification, and TI does not warrant its accuracy or completeness. TI's customers are responsible for determining suitability of components for their purposes. Customers should validate and test their design implementation to confirm system functionality.

8.1 Application Information

The TPS7A78 is a non-isolated smart AC/DC linear-voltage regulator capable of providing a maximum 120-mA load current; see [Figure 14](#) and [Figure 15](#) for the HB and FB configurations, respectively.

Being highly customizable, the TPS7A78 can be used in many low-power AC-to-DC or DC-to-DC applications, such as electricity meters, appliances, and thermostat controls. [Figure 18](#) shows an example configuration for a single-phase AC supply.

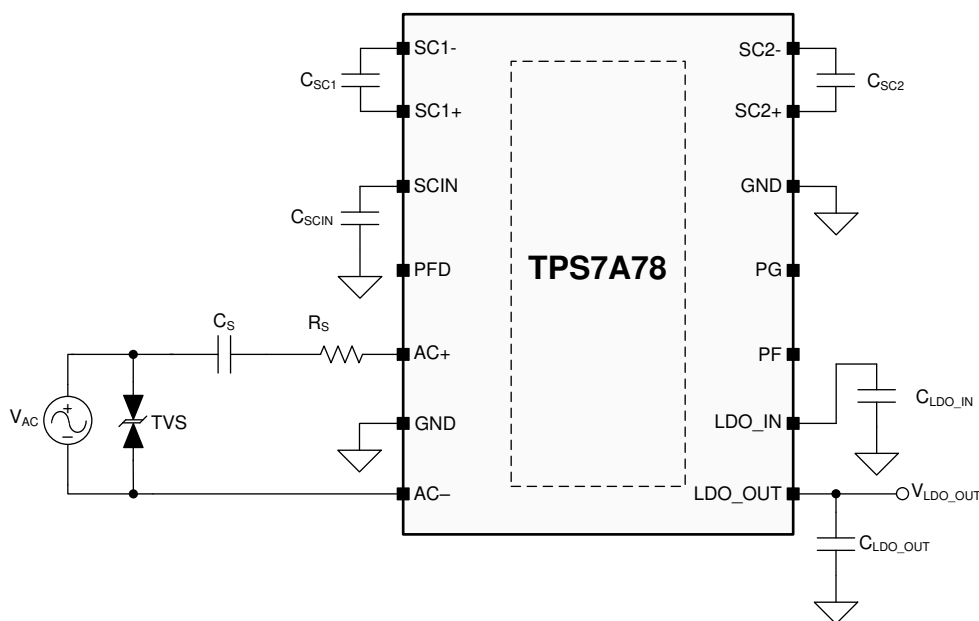

Figure 18. Implementation Example for the TPS7A78 Single-Phase AC Supply

8.1.1 Recommended Capacitor Types

The choice of capacitor types is flexible as long as the minimum derated capacitor values and capacitor voltage ratings are met.

Based on the system design requirements, TI recommends that greater than the minimum capacitor values and voltage ratings, as well as better than minimum-required dielectric materials for all device capacitors, be specified to ensure optimal performance. Choose the correct high-voltage, safety-rated cap-drop capacitor, C_S , as required by the application. Regardless of the capacitor types selected, the effective capacitance varies with operating voltage, temperature, and time. Follow the manufacturer recommendations for component derating.

8.1.2 Input and Output Capacitors Requirements

All the capacitors illustrated in [Figure 14](#) or [Figure 15](#) are required for proper operation. The value of C_S required to support the application current is obtained from the [Calculating the Cap-Drop Capacitor \$C_S\$](#) section. The chosen C_S capacitor must tolerate the peak V_{AC} supply voltage of the application and meet the required safety requirements.

Application Information (continued)

Choosing an a larger value of the C_S capacitor than required has an adverse effect on the standby power consumption; however, capacitance reduction over long-term service is inevitable and must be considered when selecting the value of C_S . A ceramic capacitor can be used as C_S in designs for lower AC supply voltages, but the capacitor voltage rating must be appropriate to the application.

For switching capacitors C_{SC1} and C_{SC2} , select the minimum-required capacitor values and voltage ratings specified in the [Recommended Operating Conditions](#) table. Using too large of a capacitor for the switching capacitors is not recommended because a large capacitor lengthens the start-up time and load transient recovery time of the entire solution. Keep the switching capacitors as close to the device as possible to eliminate any unwanted trace inductance.

For the bulk capacitor C_{SCIN} , use the minimum required capacitor value obtained from the [Calculating the Bulk Capacitor \$C_{SCIN}\$](#) section and increase that value based on the expected capacitor degradation resulting from aging and operating conditions. Accounting for capacitor degradation is especially important if a relatively low life expectancy of the capacitor is expected when an electrolytic capacitor is used. If the application requires an extended hold-up time, the values of the C_{SCIN} or C_{LDO_IN} capacitors can be increased as long as the maximum capacitor values specified in the [Recommended Operating Conditions](#) table are not exceeded. Using a significantly larger values of C_{SCIN} or C_{LDO_IN} has an adverse effect on the startup time of the solution.

For the C_{LDO_OUT} capacitor, maintain a 10:1 ratio between C_{LDO_IN} and C_{LDO_OUT} for applications using the maximum load current. For lesser load currents, the minimum required C_{LDO_OUT} and C_{LDO_IN} capacitors are sufficient. For optimum performance, place all capacitors as close as possible to the device.

8.1.3 Startup Behavior

The device startup time is dependent on the circuit topology (FB versus HB configuration), AC supply voltage and frequency, input capacitors values, and output voltage. The FB configuration has a faster startup time compared to the HB configuration. Having a larger than minimum C_S capacitor value shortens the startup time without exceeding the maximum I_{SHUNT} current specified in the [Recommended Operating Conditions](#) table. However, startup behavior depends on which C_{SCIN} and C_{LDO_IN} capacitor values are used. [Figure 19](#) illustrates the startup behavior with the minimum required C_{SCIN} capacitor and a typical C_{LDO_IN} capacitor to support 30 mA of load current with the FB configuration. [Figure 20](#) illustrates the startup behavior with the minimum required C_{SCIN} capacitor and a large C_{LDO_IN} capacitor in the same configuration.

Although the load current has no effect on startup time or startup behavior, the bulk capacitor C_{SCIN} and input capacitor C_{LDO_IN} have a significant effect on the time and behavior; see [Figure 19](#) and [Figure 20](#). For some applications, larger C_{SCIN} or C_{LDO_IN} capacitors are used to hold-up the output voltage on for a longer period of time after the input collapses.

Application Information (continued)

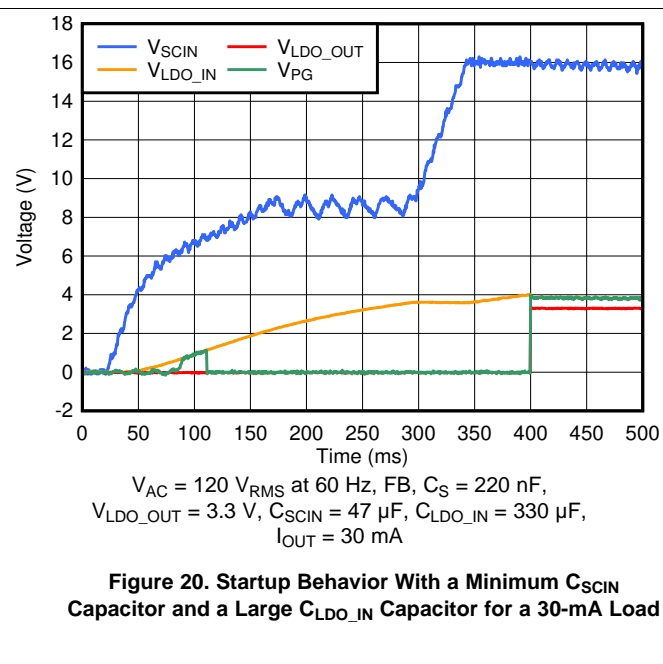
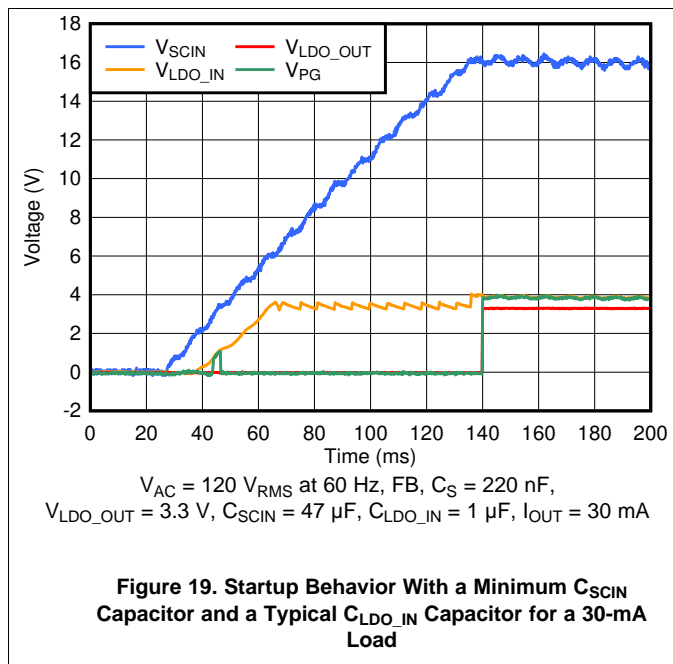

8.1.4 Load Transient

A load-transient event can trigger the internal overcharge protection circuit on the LDO_IN pin. This condition prevents C_{LDO_IN} from overcharging when a heavy load is abruptly removed. The overvoltage protection circuit engages and prevents the switched capacitors from switching until the excess charge on C_{LDO_IN} is discharged into the load. This protection behavior occurs most often during heavy load-transient events on devices with higher output voltages. The value of the C_{LDO_IN} capacitor and the load current determine how long the overvoltage protection circuit remains engaged. Figure 21 shows the overvoltage protection circuit behavior after the load is removed without tripping the PG signal.

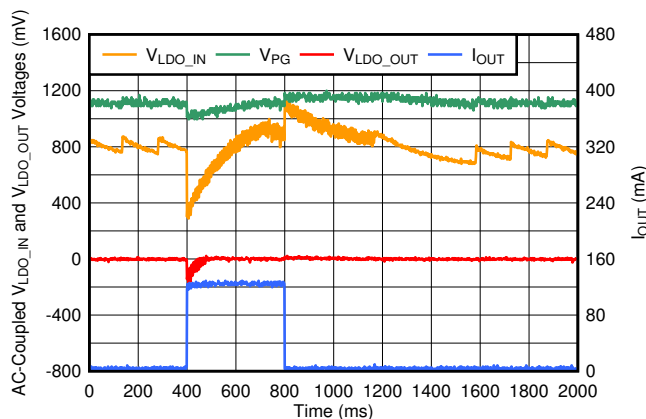
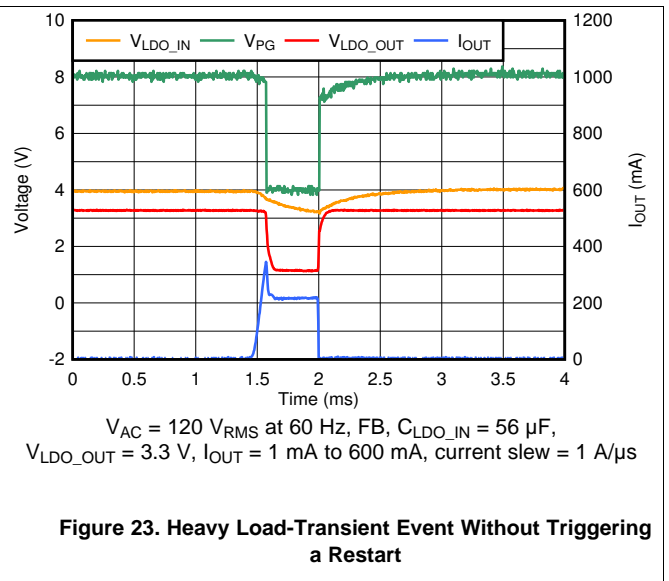
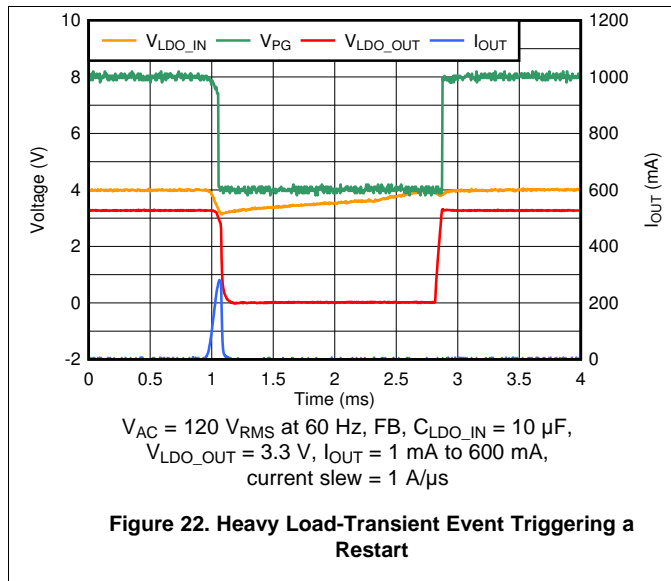

Figure 21. Overvoltage Protection Circuit Behavior for a 5.0-V Output Voltage Device During Load Transient

As illustrated in Figure 22, a load-transient event that exceeds the maximum output current can disable the output when the heavy load pulls down the V_{LDO_IN} voltage below the $V_{UVLO_LDO_IN}$ falling threshold. If the application is prone to heavy load-transient events as illustrated in Figure 22, increase the C_{LDO_IN} capacitor value as necessary. However, as illustrated in Figure 20, too large of a C_{LDO_IN} leads to a longer startup time.

Application Information (continued)



8.1.5 Standby Power and Output Efficiency

The AC input current cannot be directly calculated because of the active bridge control; see the *Active Bridge Control* section. The AC input current through the AC+ and AC– pins is a combination of two current components, as shown in Figure 24: I_{SHUNT} and I_{PEAK} . The I_{SHUNT} current component is identified by its wave profile because this component is the AC charging current supplied by the cap-drop capacitor C_S . The I_{PEAK} current component is identified by its instantaneous peak current profile.

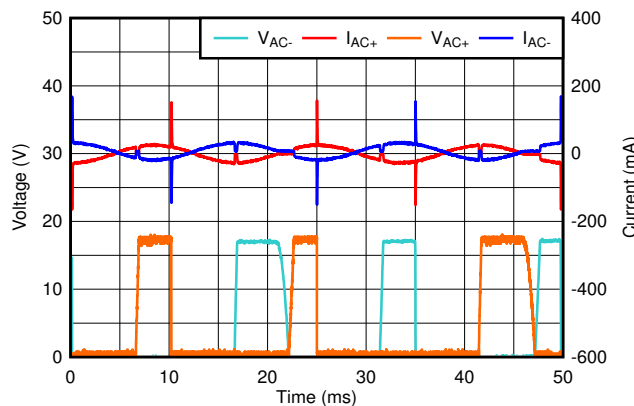

Figure 24. The Device V_{AC} Input Current With its Two Components

Equation 1 calculates the shunt current I_{SHUNT} , and Equation 2 calculates the peak current I_{PEAK} .

$$I_{SHUNT} = V_{AC (MAX)} / X_{C_S} = V_{AC (MAX)} \times 2 \times \pi \times f \times C_S \tag{1}$$

$$I_{PEAK} = V_{SCIN} / R_S \tag{2}$$

$$V_{SCIN} = 4 \times (V_{LDO_OUT (nom)} + 0.6 V)$$

where

- $V_{AC (MAX)}$ is the maximum V_{AC} supply RMS voltage
- X_{C_S} is the impedance of the standard C_S capacitor to be used in the application
- V_{SCIN} is the rectified DC voltage on the SCIN pin
- R_S is the standard R_S resistor to be used in the application (3)

Application Information (continued)

The frequency of the shunt activity is uncorrelated to the AC input frequency. Therefore, the standby power must be measured with a power analyzer. Fortunately, using a power analyzer is relatively simple and the measurement setup shown in Figure 25 and Figure 26 can be used to measure the standby power and the output efficiency.

If the application has an upstream current-limit circuit that limits any high-transient input currents, such as surge or hot-plug currents, the requirement for the surge resistor R_S can be relaxed. The input transient current-limit circuit allows the R_S resistor to be removed, thus significantly improving the standby power and output efficiency because no power loss is dissipated in R_S .

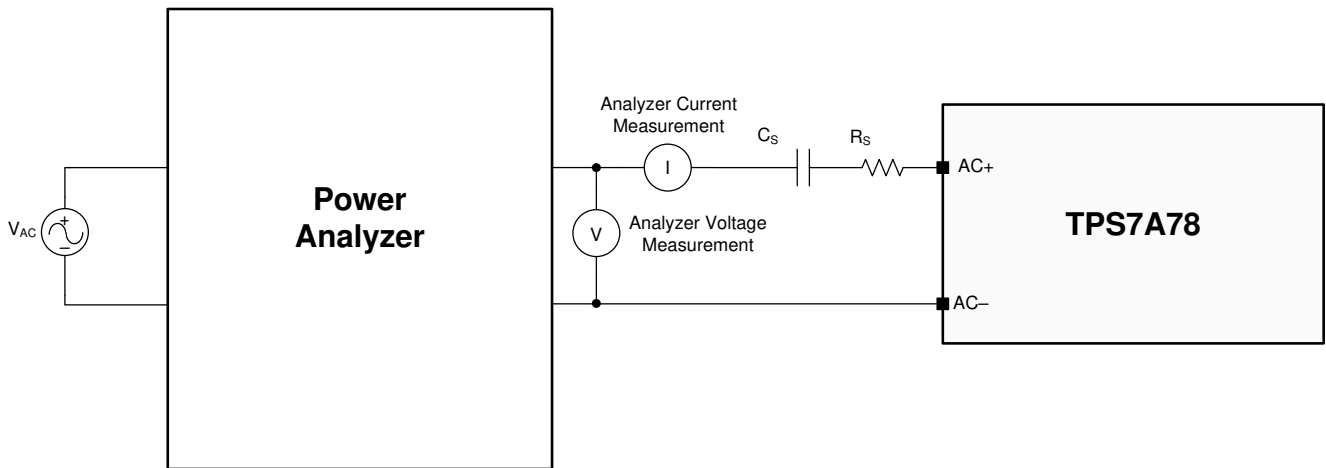

Figure 25. Standby Power and Output Efficiency Measurement Setup

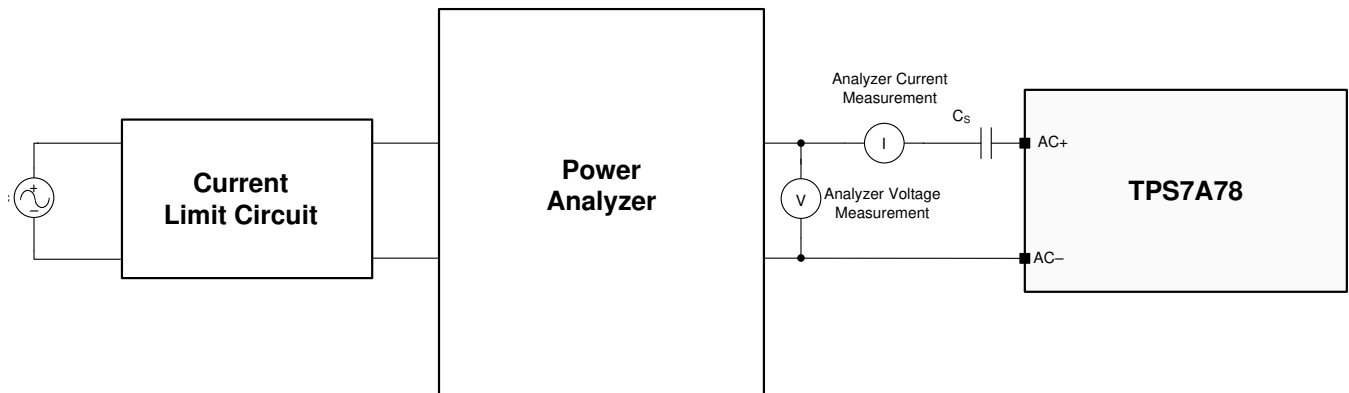
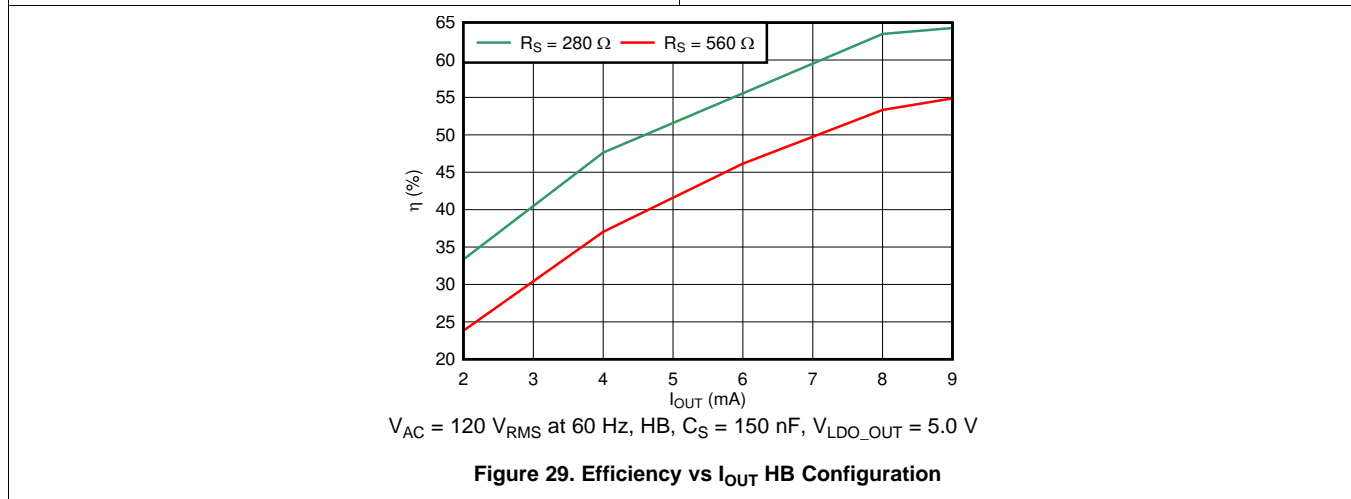
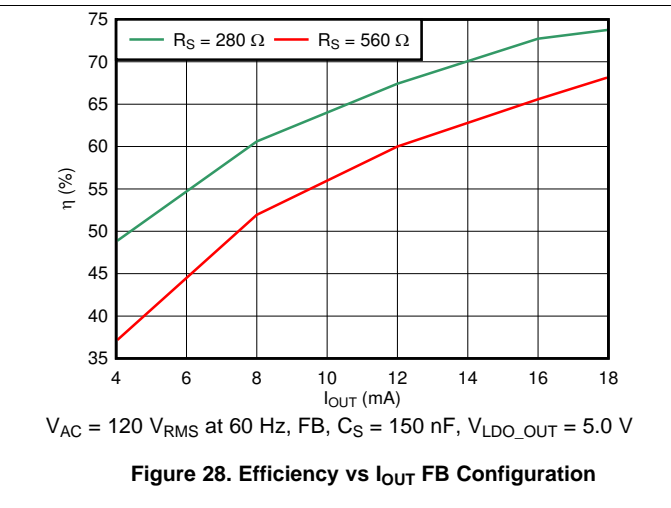
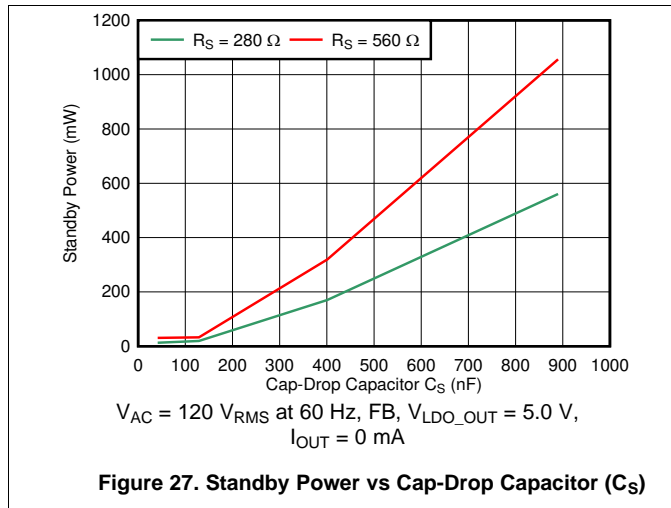

Figure 26. Standby Power and Output Efficiency Measurement Setup With an Upstream Current-Limit Circuit

Application Information (continued)

The standby power and output efficiency measurements shown in Figure 27 to Figure 29 were created with the measurement setup in Figure 25.



8.1.6 Reverse Current

Excessive reverse current can damage the TPS7A78. Reverse current flows through the intrinsic body diode of the pass-transistor instead of the normal conducting channel. At high magnitudes, this current flow degrades the long-term reliability of the device.

Conditions where reverse current can occur are:

- If the device has a large C_{LDO_OUT} and the input supply collapses with little or no load current
- The LDO_OUT pin is biased when the input supply is not present
- The LDO_OUT pin is biased above the voltage of the LDO_IN pin

If reverse current flow is expected in the application, external protection is recommended to provide protect. Reverse current is not limited within the device, so external limiting is required, as illustrated in Figure 30 and Figure 31, if extended reverse-voltage operation is anticipated.

Application Information (continued)

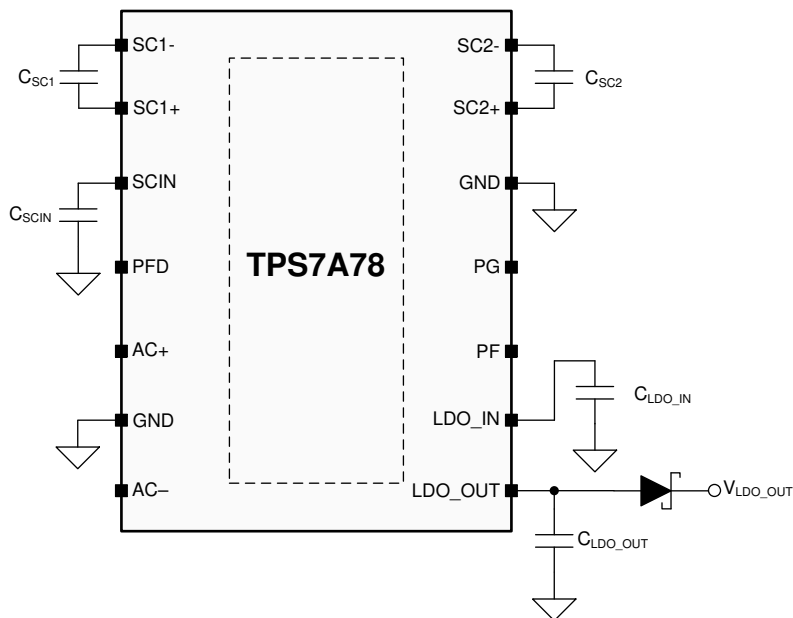

Figure 30. Example Circuit for Reverse Current Protection Using a Schottky Diode

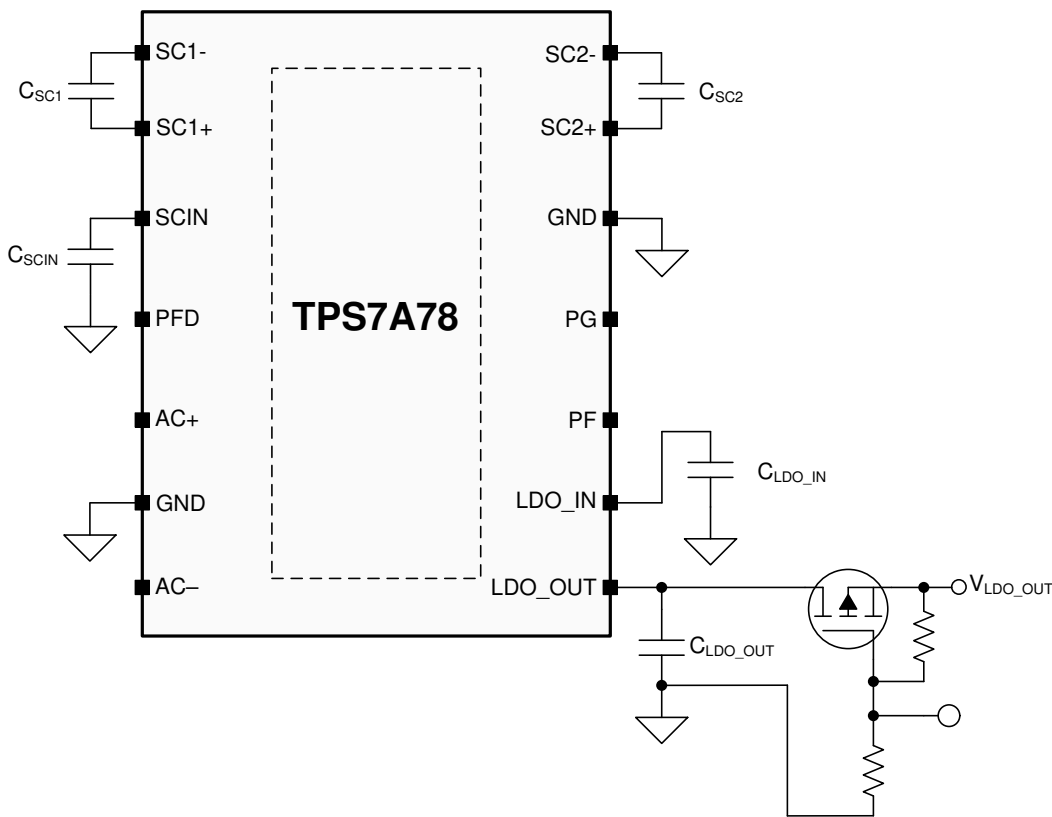

Figure 31. Example Circuit for Reverse Current Protection Using a P-Channel FET

Application Information (continued)

8.1.7 Switched-Capacitor Stage Output Impedance

To ensure a low output impedance of the device switched-capacitor stage (charge pump), connect a 1- μ F X5R or a better dielectric capacitor in parallel with the bulk capacitor C_{SCIN} . Figure 32 shows the switched-capacitor stage output impedance versus temperature at the maximum output current of 120 mA. When a DC supply power source is used to power the device under heavy loading conditions close to the maximum current rating at high temperature, the load can run the LDO into dropout because of the degradation in the charge pump output impedance. To enhance performance with a DC supply, apply the DC supply voltage to the SCIN pin equal to 4 (VLDO_OUT (nom) + 0.6 V) + 2 V to ensure optimal performance. See Figure 5 and Figure 6 for a 3.3-V output voltage example.

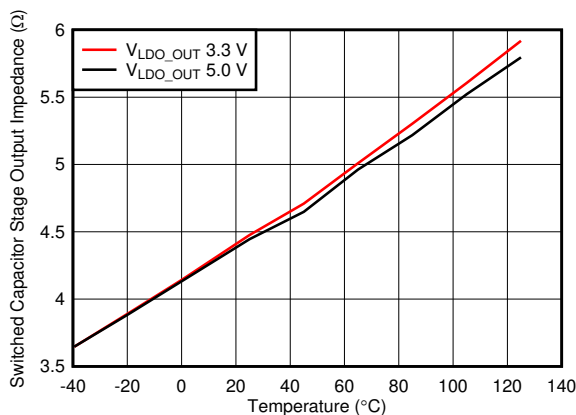

Figure 32. Switched-Capacitor Stage Output Impedance vs Temperature at a 120-mA Load Current

8.1.8 Power Dissipation (P_D)

To ensure proper thermal design, the printed circuit board (PCB) area around the TPS7A78 must include a minimal of heat-generating devices to avoid added thermal stress. The three internal sources that dissipate power are: the bridge rectifier conduction losses, the switched-capacitor stage, and the LDO. For devices with an output voltage greater 3.3 V, the maximum power dissipation under a maximum load current of 120 mA is estimated to be between 160 mW and 190 mW, assuming a nominal C_S capacitor value for the given load current. For applications with less than a 3.3-V output, the power dissipated in the LDO is the dominant power and can be calculated using Equation 4 because the dropout voltage between V_{LDO_IN} and V_{LDO_OUT} can be as high as 2.7 V for the 1.3-V output option. See the [Dropout Voltage Regulation](#) section for details on dropout voltage.

$$P_{D_LDO} = (V_{LDO_IN} - V_{LDO_OUT}) \times I_{OUT} \tag{4}$$

The higher dropout for less than 2.0-V output voltage options may run the device into thermal limitations at the startup ramp for higher temperatures, especially with the large LDO_OUT pin capacitor or when close to the maximum load. The thermal pad under the TPS7A78 must contain an array of filled vias that conduct heat to additional copper planes for increased heat dissipation. The amount of thermal dissipation determines the maximum allowable ambient temperature (T_A) for the device. According to Equation 5, power dissipation and junction temperature are determined by the junction-to-ambient thermal resistance ($R_{\theta JA}$) of the combined PCB and device package as well as the temperature of the ambient air (T_A).

$$T_J = T_A + (R_{\theta JA} \times P_D) \tag{5}$$

Thermal resistance ($R_{\theta JA}$) is highly dependent on the heat-spreading capability built into the particular PCB design, and therefore varies according to the total copper area, copper weight, and location of the planes. The junction-to-ambient thermal resistance listed in the [Thermal Information](#) table is determined by the JEDEC standard PCB and copper-spreading area, and is used as a relative measure of package thermal performance, but not indicative of performance in any particular implementation.

Application Information (continued)

8.1.9 Estimating Junction Temperature

The JEDEC standard recommends the use of psi (Ψ) thermal metrics to estimate the junction temperatures of the linear regulator when in circuit on a typical PCB board application. These metrics are not thermal resistance parameters and instead offer a practical and relative way to estimate junction temperature. These psi metrics are determined to be significantly independent of the copper area available for heat spreading. The [Thermal Information](#) table lists the primary thermal metrics, which are the junction-to-top characterization parameter (Ψ_{JT}) and junction-to-board characterization parameter (Ψ_{JB}). These parameters provide two methods for calculating the junction temperature (T_J). As described in the [Semiconductor and IC Package Thermal Metrics application report](#), use the junction-to-top characterization parameter (Ψ_{JT}) with the temperature at the center-top of device package (T_T) to calculate the junction temperature. As described in the [Semiconductor and IC Package Thermal Metrics application report](#), use the junction-to-board characterization parameter (Ψ_{JB}) with the PCB surface temperature 1 mm from the device package (T_B) to estimate the junction temperature.

$$T_J = T_T + \Psi_{JT} \times P_{D_Total}$$

where

- P_{D_Total} is the total dissipated power in the device
- T_T is the temperature at the center-top of the device package

$$T_J = T_B + \Psi_{JB} \times P_D$$

where

- T_B is the PCB surface temperature measured 1 mm from the device package and centered on the package edge

For detailed information on the thermal metrics and how to use them, see the [Semiconductor and IC Package Thermal Metrics application report](#).

8.2 Typical Application

This section demonstrates the design process for a typical application of the TPS7A78, including the calculation of the values of the external components required for proper operation. [Figure 33](#) shows an optimized electricity meter application using an HB configuration. For this design, the AC supply line voltage is referenced to the TPS7A78 GND pins to share the same GND as the system microcontroller.

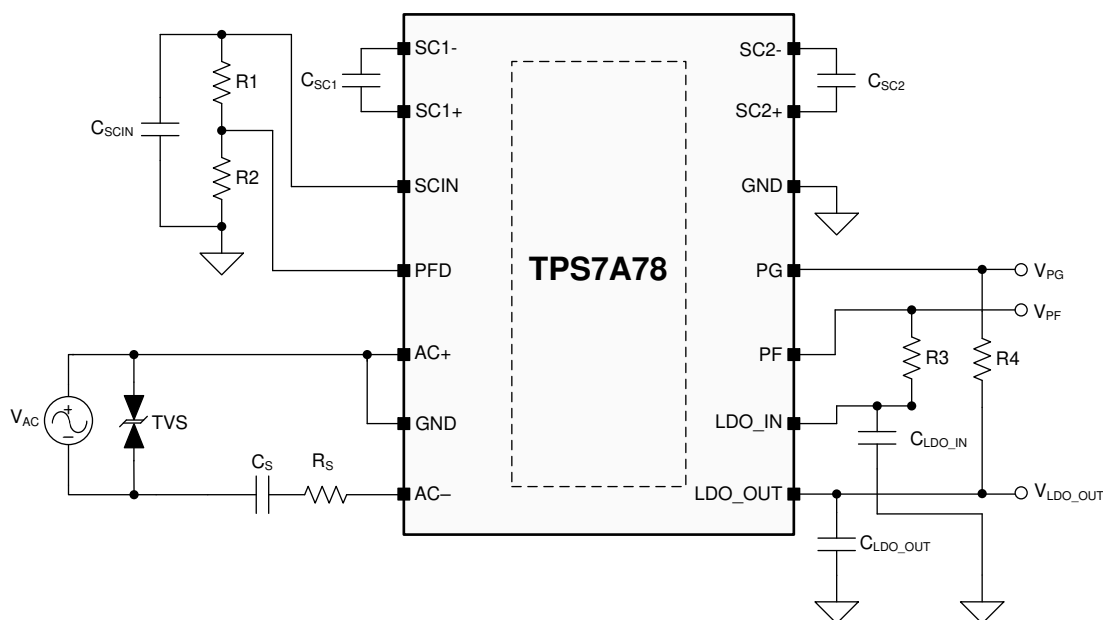

Figure 33. Example for a Single-Phase Electricity Meter Configuration

Typical Application (continued)

8.2.1 Design Requirements

Table 2 summarizes the design requirement for this example.

Table 2. Design Parameters

PARAMETER	DESIGN REQUIREMENT
V _{AC} supply voltage	85 V _{AC RMS} to 265 V _{AC RMS}
V _{AC} supply frequency	50 Hz (±3 Hz)
Bridge configuration	HB, AC+ pin is tied to the device GND pins
Device GND pins reference	Floating device GND, AC supply line voltage is referenced to the device GND pins
Output voltage	3.3 V
Output current	12 mA
Electrical fast transient immunity (EFT)	(IEC 61000-4-4) level 2 (1 kV)

8.2.2 Detailed Design Procedure

This section discusses how to calculate the external components required for this design example.

8.2.2.1 Calculating the Cap-Drop Capacitor C_S

Use Equation 8 to calculate the minimum required cap-drop capacitance needed to support the application current. For common application conditions, Table 3 can be used to select the minimum standard cap-drop capacitor required to support the application current. However, neither Equation 8 nor Table 3 account for capacitance derating under biasing voltage and operating temperature conditions. Follow the manufacturer recommendation and guidelines on capacitor derating and degradation to ensure the minimum-required capacitance needed for the application under various operating conditions. Do not use a load current less than 10 mA to calculate the C_S capacitor because the device current is a larger fraction of the load current. Equation 8 and Table 3 can also be used to calculate the value of C_S depending on the application V_{AC (MIN)} voltage and frequency and then use the highest value for the application.

$$C_S = I_{OUT} / (16 \times f \times [\sqrt{2} \times V_{AC (MIN)} - 4 \times (V_{LDO_OUT (nom)} + 0.6 V)])$$

where

- the C_S value is the minimum cap-drop capacitance value in farads needed to support I_{OUT}
- I_{OUT} is the application nominal load current, but the application peak current must be considered if this current cannot be supported by the LDO output capacitor
- V_{LDO_OUT} is the targeted LDO output voltage
- V_{AC (MIN)} is the minimum RMS V_{AC} supply voltage
- f is the minimum V_{AC} line frequency

(8)

Table 3. The Minimum Required Cap-Drop Capacitor C_S

V _{AC (MIN)} (f)	I _{OUT} (mA)	C _S FOR FB (nF)	C _S FOR HB (nF)
120 (60)	10	100	220
	30	330	470
	60	560	1000
	90	820	1500
	120	1000	2200
240 (50)	10	47	100
	30	150	330
	60	330	560
	90	470	820
	120	560	1200

The capacitance value of C_S from Equation 8 is for the FB configuration. For the HB configuration, double the calculated capacitance value, then approximate the value up to the nearest standard capacitor value after taking capacitance degradation into account. Similarly, the capacitor value of C_S from Table 3 represents the minimum required capacitor value and is already approximated to the nearest standard value but capacitor degradation is not accounted for.

8.2.2.1.1 C_S Calculations for the Typical Design

Equation 8 yields a capacitance value of 153 nF, as given by Equation 9, which results from the $V_{AC (MIN)}$ voltage and frequency of this application. This value is for the FB configuration. For the HB configuration, doubling the calculated capacitance value yields 306 nF, and approximate this value up to the nearest standard capacitor value, which yields a C_S value of 330 nF.

$$C_S = (0.012) / (16 \times 47 \times [\sqrt{2} \times 85 - 4(3.3 + 0.6)]) = 153 \text{ nF} \quad (9)$$

As mentioned in the [Calculating the Cap-Drop Capacitor \$C_S\$](#) and [Input and Output Capacitors Requirements](#) sections, capacitance loss under long-term service is inevitable and must be considered in the design. Follow the manufacturer recommendations and guidelines for capacitor derating and degradation over time.

8.2.2.2 Calculating the Surge Resistor R_S

The device requires a surge resistor or resistors in series with the AC+ and or AC– pins, depending configuration; see the [Full-Bridge \(FB\) and Half-Bridge \(HB\) Configurations](#) section for details. The purpose of the surge resistor is to limit the hot-plug AC current into the AC+ and AC– pins when the AC supply voltage is applied. Equation 10 calculates the value of the minimum surge resistor $R_{S (MIN)}$ required for the application.

$$R_{S (MIN)} = V_{AC (PEAK)} / I_{Surge (MAX)}$$

where

- $V_{AC (PEAK)}$ is the peak V_{AC} supply voltage for the application
- $I_{Surge (MAX)}$ is the maximum V_{AC} current into or out of the AC+ or AC– pins for a duration of $\leq 100 \mu\text{s}$, as specified in the [Recommended Operating Conditions](#) table. (10)

If the solution requires the use of a transient voltage surge suppressor (TVS) or a metal-oxide varistor (MOV), then use the maximum clamping voltage of the TVS or MOV instead of the peak V_{AC} voltage in Equation 10. After calculating $R_{S (MIN)}$, select the next-higher standard resistor value.

8.2.2.2.1 R_S Calculations for the Typical Design

The peak AC supply voltage for this example is equal to 375 V ($\sqrt{2} \times 265$) and the electrical fast transient immunity (EFT) requirement is given as 1 kV. Thus, a TVS with a maximum clamping voltage of 1000 V can be used. Equation 11 shows the calculated $R_{S (MIN)}$ value.

$$R_{S (MIN)} = 1000 / 2.5 = 400 \Omega \quad (11)$$

Because both the device I_{PEAK} current and the device maximum I_{SHUNT} current flow through R_S , the power rating of R_S must be able to handle these currents values. See the [Checking for the Device Maximum \$I_{SHUNT}\$ Current](#) section for the I_{SHUNT} current calculation and R_S power rating for this application.

If the application already has an upstream hot-plug current-limit circuit, then the requirement for the surge resistor can be relaxed to significantly improve the solution standby-power; see the [Standby Power and Output Efficiency](#) section for details.

8.2.2.3 Checking for the Device Maximum I_{SHUNT} Current

After determining the cap-drop capacitor value, a check must be performed to confirm that the maximum I_{SHUNT} current specified in the [Recommended Operating Conditions](#) table is not exceeded by the standard capacitor value of C_S . Other factors that affect the I_{SHUNT} current are the maximum AC supply RMS voltage and the maximum line frequency.

8.2.2.3.1 I_{SHUNT} Calculations for the Typical Design

Given the maximum AC supply voltage and the minimum frequency for this application example, the calculated I_{SHUNT} current using Equation 1 from the *Standby Power and Output Efficiency* section yields:

$$I_{SHUNT} = 265 \times 2 \times \pi \times 53 \times 330 \times 10^{-9} = 0.02912 \text{ A} \quad (12)$$

NOTE

The *Recommended Operating Conditions* table does not specify the maximum AC voltage that can be used because the maximum V_{AC} voltage is bound by the maximum I_{SHUNT} current and the availability of the high-voltage cap-drop capacitor.

The RMS power given in Equation 13 and the peak power given in Equation 14 must be used to determine the power rating of the surge resistor R_S.

$$P_{RMS} = (I_{SHUNT})^2 \times R_S \quad (13)$$

$$P_{PEAK} = [I_{SHUNT} \times R_S + 4(V_{LDO_OUT(nom)} + 0.6 \text{ V})]^2 / R_S \quad (14)$$

Using Equation 13 and Equation 14 yields the following R_S power ratings:

$$P_{RMS} = (0.02912)^2 \times 400 = 0.34 \text{ W} \quad (15)$$

$$P_{PEAK} = [0.02912 \times 400 + 4(3.3 + 0.6)]^2 / 400 = 1.86 \text{ W} \quad (16)$$

Use the power rating resulting from Equation 14 because this equation yields a higher power requirement. Furthermore, additional margin is always a good design practice.

8.2.2.4 Calculating the Bulk Capacitor C_{SCIN}

The TPS7A78 uses a bulk capacitor C_{SCIN} to smooth the rectified DC voltage ripple on the SCIN pin and to supply charge to the switched capacitor stage; see the *4:1 Switched-Capacitor Voltage Reduction* section. The C_{SCIN} capacitor also functions as a charge reservoir to hold-up the device output voltage for a period of time if the supply collapses. The minimum value of the C_{SCIN} capacitor required can be calculated using Equation 17 through Equation 20, however these equations make the following assumptions to simplify the C_{SCIN} capacitor calculation:

- The AC supply frequency is within ±5% of the nominal standard frequencies of 50 Hz and 60 Hz
- The voltage ripple on the SCIN pin is around from 0.5 V to 0.8 V.
- The AC impedance of the cap-drop capacitor C_S is at least ten times lower than that of the bulk capacitor C_{SCIN} and the surge resistor R_S

Use Equation 17 for the FB 60-Hz V_{AC} supply and Equation 18 for the HB 60-Hz V_{AC} supply.

$$C_{SCIN} = 0.0014 \times I_{OUT} \quad (17)$$

$$C_{SCIN} = 0.0035 \times I_{OUT} \quad (18)$$

Use Equation 19 for the FB 50-Hz V_{AC} supply and Equation 20 for the HB 50-Hz V_{AC} supply.

$$C_{SCIN} = 0.0017 \times I_{OUT} \quad (19)$$

$$C_{SCIN} = 0.0041 \times I_{OUT}$$

where

- I_{OUT} is the application load current (20)

The calculated C_{SCIN} capacitor from Equation 17 through Equation 20 represents the minimum value required for the application example. However, Equation 17 through Equation 20 do not account for capacitance derating for all operating conditions. Follow the manufacturer recommendation and guidelines to ensure the minimum required capacitance needed for the application. See the *Input and Output Capacitors Requirements* section for more details.

8.2.2.4.1 C_{SCIN} Calculations for the Typical Design

Equation 21 shows the use of Equation 20 to calculate the C_{SCIN} capacitor value for the requirements of this application example.

$$C_{SCIN} = 0.0041 \times 0.012 = 49.2 \mu\text{F} \quad (21)$$

The calculated C_{SCIN} capacitor from the equations in the [Calculating the Bulk Capacitor C_{SCIN}](#) section represents the minimum value required for the respective device configuration. Choose the nearest standard capacitor value; see the [Input and Output Capacitors Requirements](#) section for more details.

8.2.2.5 Calculating the PFD Pin Resistor Dividers for a Power-Fail Detection

Using the device power-fail detection feature is optional as indicated in [Figure 14](#) and [Figure 15](#). The PFD pin is an analog voltage input to an internal comparator that drives the open-drain PF output. The resistor divider consisting of R₁ and R₂ can be used to set the minimum V_{SCIN} voltage that triggers the PF output. Regardless of whether an AC or DC supply is used, the PF output triggers when the supply fails to maintain the V_{SCIN} voltage above V_{SCIN (MIN)}. Equation 22 gives the calculation of the R₁ – R₂ resistor divider that sets the PF pin trigger point.

$$V_{IT(PFD,FALLING)} \text{ threshold} = (V_{SCIN (MIN)} - V_{\text{ripple on the SCIN pin}}) \times [R_2 / (R_1 + R_2)]$$

where

- V_{Ripple} is the peak-to-peak voltage ripple on the SCIN pin and is in the range of 0.5 V to 0.8 V (22)

Equation 23 calculates the V_{SCIN (MIN)} voltage.

$$V_{SCIN (MIN)} = 4 (V_{LDO_OUT (nom)} + 0.6 \text{ V}) - 1.5 \text{ V} \quad (23)$$

Set R₁ as close as possible to the maximum value specified in the [Recommended Operating Conditions](#) table. This high R₁ value limits the power used by the resistors, then calculates the value of R₂. Choose the closest standard resistor value for R₂. Optionally, because the PFD pin is a high-impedance node, add a 10-pF capacitor in parallel with the R₂ resistors to reduce noise coupling into V_{PFD}.

Pull up the PF pin to a DC rail, such as V_{LDO_IN}, so that a microcontroller can monitor the PF signal as an early power-fail warning to trigger the switch to a backup power solution or to perform a controlled system shutdown. Pulling up the PF pin to V_{LDO_IN} rather than V_{LDO_OUT} ensures that the PF signal is continuously monitored even if V_{LDO_OUT} is down because of a load-transient event or a short-circuit fault.

NOTE

An external DC rail can also be used to pullup the PF pin signal via a pullup resistor only if the external DC rail shares a common ground with the device GND pins and the absolute maximum of the PF pin voltage is not exceeded.

8.2.2.5.1 PFD Pin Resistor Divider Calculations for the Typical Design

Using Equation 23 and then solving Equation 22 for R₂ yields an R₂ value of 18.3 kΩ.

$$V_{SCIN (MIN)} = 4 (3.3 + 0.6) - 1.5 \text{ V} = 14.1 \text{ V} \quad (24)$$

$$R_2 = (V_{IT(PFD,FALLING)} \times R_1) / (V_{SCIN (MIN)} - V_{\text{ripple on the SCIN pin}} - V_{IT(PFD,FALLING)}) \quad (25)$$

$$R_2 = (1.17 \times 200) / (14.1 - 0.5 - 1.17) \quad (26)$$

8.2.2.6 Summary of the Typical Application Design Components

Table 4 summarizes the component values chosen through the design process for this application example.

Table 4. Typical Application Design Example Components

COMPONENT	CALCULATED VALUE
C _S	330 nF, capacitance loss under long-term service is inevitable and must be considered in the design.
R _S	400 Ω, see the Checking for the Device Maximum I_{SHUNT} Current section for the R _S power-rating calculation.
C _{SCIN}	47 μF, approximate the 49.2-μF capacitor value resulting from the Calculating the Bulk Capacitor C_{SCIN} section.
C _{SC1}	1 μF, select the minimum capacitor value specified in the Recommended Operating Conditions table.
C _{SC2}	1 μF, select the minimum capacitor value specified in the Recommended Operating Conditions table.
C _{LDO_IN}	1 μF, select the typical capacitor value specified in the Recommended Operating Conditions table.
C _{LDO_OUT}	1 μF, select the typical capacitor value specified in the Recommended Operating Conditions table.
R ₁	200 kΩ, select the maximum resistor value specified in the Recommended Operating Conditions table.
R ₂	18.7 kΩ, approximate the 18.3-kΩ resistor value from the PFD Pin Resistor Divider Calculations for the Typical Design section.
R ₃ and R ₄	100 kΩ, select the maximum resistor values specified in the Recommended Operating Conditions table.

8.2.3 Application Curves

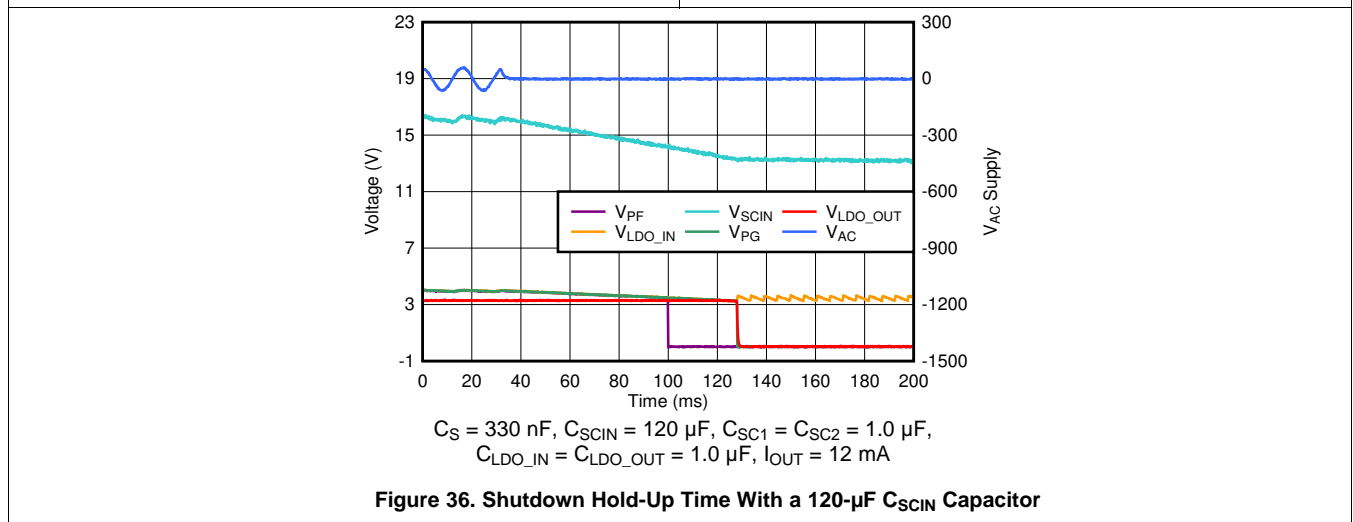
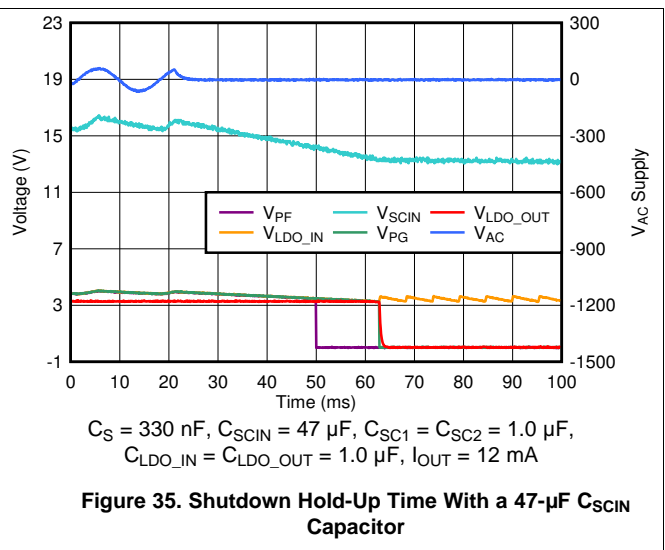
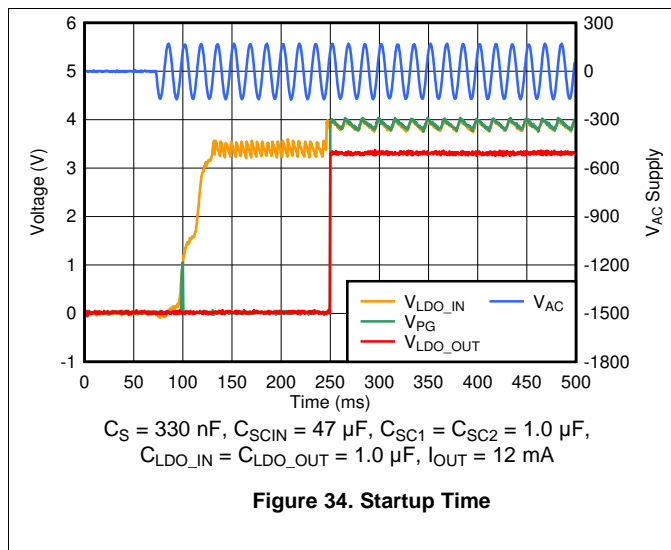

9 Power Supply Recommendations

The TPS7A78 is designed primarily to operate from an AC supply voltage $\geq 18 V_{AC}$ and an input line frequency up to 20 kHz. To ensure that the output voltage is well regulated and that dynamic performance is optimum, the procedures and examples in the [Typical Application](#) section must be followed.

The TPS7A78 can also operate from a DC supply voltage from 17 V to 23 V depending on the output voltage. To ensure proper operation and ensure that the DC output voltage is well regulated, the DC supply voltage applied to the SCIN pin must be well regulated and greater than or equal to the minimum V_{UVLO_SCIN} rising threshold specified in the [Electrical Characteristics](#) table.

10 Layout

10.1 Layout Guidelines

- Place the input and output capacitors as close to the TPS7A78 as possible
- Place the PFD resistor divider, if used, away from the AC+, AC– pins, and the switched-capacitor stage pins; if not used, tie the PFD pin to the common ground with the device GND pins
- Pull up the PG pin, if used, to the LDO_OUT pin via a pullup resistor; otherwise, tie the PG pin to the common ground with the device GND pins
- Pull up the PF pin, if used, to the LDO_IN pin via a pullup resistor; otherwise, tie the PF pin to the common ground with the device GND pins
- Follow the recommended creepage distance between the AC+ and AC– pin traces, and between these traces and other circuit traces
- Tie the AC+ and AC– pins to the device GND pins if only the DC input supply is used
- Place thermal vias around the device to distribute heat

10.2 Layout Example

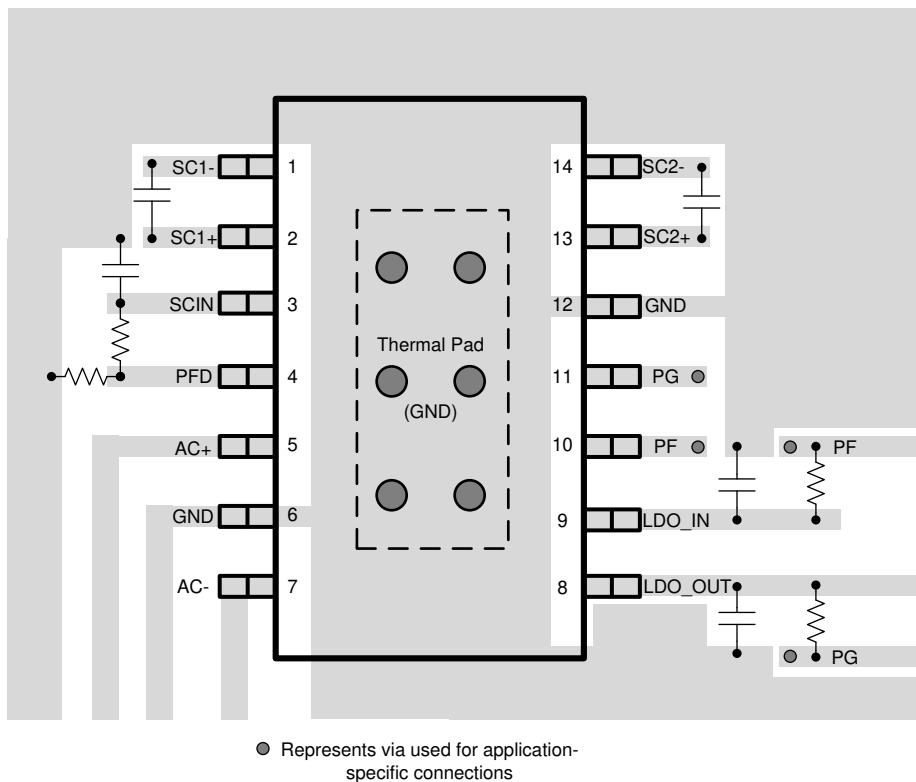

Figure 37. Example Layout

11 Device and Documentation Support

11.1 Device Support

11.1.1 Development Support

11.1.1.1 Evaluation Module

An evaluation module (EVM) is available to assist in the initial circuit performance evaluation using the TPS7A78. The [TPS7A78EVM-011 Evaluation Module user guide](#) can be requested at the Texas Instruments website through the product folders or purchased directly from the [TI eStore](#).

11.1.1.2 SIMPLIS Model

The SIMPLIS model for this device is available through the TPS7A78 product folder under the [Tool and Software](#) tab.

11.1.2 Device Nomenclature

Table 5. Device Nomenclature⁽¹⁾⁽²⁾

PRODUCT	V _{LDO_OUT}
TPS7A78xx(x)yyyz	<p>xx(x) is the nominal output voltage. For output voltages with a resolution of 50 mV, two digits are used in the ordering number; otherwise, three digits are used (for example, 33 = 3.3 V; 135 = 1.35 V).</p> <p>yyy is the package designator.</p> <p>z is the package quantity. R is for large quantity reel, T is for small quantity reel.</p>

(1) For the most current package and ordering information see the Package Option Addendum at the end of this document, or visit the device product folder on www.ti.com.

(2) Output voltages from 1.3 V to 5.0 V in 50-mV increments are available. Contact the factory for details and availability.

11.2 Documentation Support

11.2.1 Related Documentation

For related documentation see the following:

- Texas Instruments, [TPS7A78EVM-011 Evaluation module user's guide](#)
- Texas Instruments, [One-Phase Shunt Electricity Meter Reference Design Using Standalone ADCs design guide](#)
- Texas Instruments, [Off-Line \(Non-Isolated\) AC/DC Power Supply Architectures Reference Design for Grid Applications design guide](#)

11.3 Receiving Notification of Documentation Updates

To receive notification of documentation updates, navigate to the device product folder on ti.com. In the upper right corner, click on *Alert me* to register and receive a weekly digest of any product information that has changed. For change details, review the revision history included in any revised document.

11.4 Community Resources

[TI E2E™ support forums](#) are an engineer's go-to source for fast, verified answers and design help — straight from the experts. Search existing answers or ask your own question to get the quick design help you need.

Linked content is provided "AS IS" by the respective contributors. They do not constitute TI specifications and do not necessarily reflect TI's views; see TI's [Terms of Use](#).

11.5 Trademarks

E2E is a trademark of Texas Instruments.

All other trademarks are the property of their respective owners.

11.6 Electrostatic Discharge Caution



This integrated circuit can be damaged by ESD. Texas Instruments recommends that all integrated circuits be handled with appropriate precautions. Failure to observe proper handling and installation procedures can cause damage.

ESD damage can range from subtle performance degradation to complete device failure. Precision integrated circuits may be more susceptible to damage because very small parametric changes could cause the device not to meet its published specifications.

11.7 Glossary

[SLYZ022](#) — *TI Glossary*.

This glossary lists and explains terms, acronyms, and definitions.

12 Mechanical, Packaging, and Orderable Information

The following pages include mechanical, packaging, and orderable information. This information is the most current data available for the designated devices. This data is subject to change without notice and revision of this document. For browser-based versions of this data sheet, refer to the left-hand navigation.

PACKAGING INFORMATION

Orderable Device	Status (1)	Package Type	Package Drawing	Pins	Package Qty	Eco Plan (2)	Lead finish/ Ball material (6)	MSL Peak Temp (3)	Op Temp (°C)	Device Marking (4/5)	Samples
TPS7A7833PWPR	ACTIVE	HTSSOP	PWP	14	3000	RoHS & Green	NIPDAU	Level-3-260C-168 HR	-40 to 125	S7A7833	Samples
TPS7A7833PWPT	ACTIVE	HTSSOP	PWP	14	250	RoHS & Green	NIPDAU	Level-3-260C-168 HR	-40 to 125	S7A7833	Samples
TPS7A7836PWPR	ACTIVE	HTSSOP	PWP	14	3000	RoHS & Green	NIPDAU	Level-3-260C-168 HR	-40 to 125	S7A7836	Samples
TPS7A7836PWPT	ACTIVE	HTSSOP	PWP	14	250	RoHS & Green	NIPDAU	Level-3-260C-168 HR	-40 to 125	S7A7836	Samples
TPS7A7850PWPR	ACTIVE	HTSSOP	PWP	14	3000	RoHS & Green	NIPDAU	Level-3-260C-168 HR	-40 to 125	S7A7850	Samples
TPS7A7850PWPT	ACTIVE	HTSSOP	PWP	14	250	RoHS & Green	NIPDAU	Level-3-260C-168 HR	-40 to 125	S7A7850	Samples

(1) The marketing status values are defined as follows:

ACTIVE: Product device recommended for new designs.

LIFEBUY: TI has announced that the device will be discontinued, and a lifetime-buy period is in effect.

NRND: Not recommended for new designs. Device is in production to support existing customers, but TI does not recommend using this part in a new design.

PREVIEW: Device has been announced but is not in production. Samples may or may not be available.

OBSOLETE: TI has discontinued the production of the device.

(2) **RoHS:** TI defines "RoHS" to mean semiconductor products that are compliant with the current EU RoHS requirements for all 10 RoHS substances, including the requirement that RoHS substance do not exceed 0.1% by weight in homogeneous materials. Where designed to be soldered at high temperatures, "RoHS" products are suitable for use in specified lead-free processes. TI may reference these types of products as "Pb-Free".

RoHS Exempt: TI defines "RoHS Exempt" to mean products that contain lead but are compliant with EU RoHS pursuant to a specific EU RoHS exemption.

Green: TI defines "Green" to mean the content of Chlorine (Cl) and Bromine (Br) based flame retardants meet JS709B low halogen requirements of <=1000ppm threshold. Antimony trioxide based flame retardants must also meet the <=1000ppm threshold requirement.

(3) MSL, Peak Temp. - The Moisture Sensitivity Level rating according to the JEDEC industry standard classifications, and peak solder temperature.

(4) There may be additional marking, which relates to the logo, the lot trace code information, or the environmental category on the device.

(5) Multiple Device Markings will be inside parentheses. Only one Device Marking contained in parentheses and separated by a "~" will appear on a device. If a line is indented then it is a continuation of the previous line and the two combined represent the entire Device Marking for that device.

(6) Lead finish/Ball material - Orderable Devices may have multiple material finish options. Finish options are separated by a vertical ruled line. Lead finish/Ball material values may wrap to two lines if the finish value exceeds the maximum column width.

Important Information and Disclaimer: The information provided on this page represents TI's knowledge and belief as of the date that it is provided. TI bases its knowledge and belief on information provided by third parties, and makes no representation or warranty as to the accuracy of such information. Efforts are underway to better integrate information from third parties. TI has taken and continues to take reasonable steps to provide representative and accurate information but may not have conducted destructive testing or chemical analysis on incoming materials and chemicals. TI and TI suppliers consider certain information to be proprietary, and thus CAS numbers and other limited information may not be available for release.

In no event shall TI's liability arising out of such information exceed the total purchase price of the TI part(s) at issue in this document sold by TI to Customer on an annual basis.

TAPE AND REEL INFORMATION

QUADRANT ASSIGNMENTS FOR PIN 1 ORIENTATION IN TAPE

*All dimensions are nominal

Device	Package Type	Package Drawing	Pins	SPQ	Reel Diameter (mm)	Reel Width W1 (mm)	A0 (mm)	B0 (mm)	K0 (mm)	P1 (mm)	W (mm)	Pin1 Quadrant
TPS7A7833PWPR	HTSSOP	PWP	14	3000	330.0	12.4	6.9	5.6	1.6	8.0	12.0	Q1
TPS7A7833PWPT	HTSSOP	PWP	14	250	330.0	12.4	6.9	5.6	1.6	8.0	12.0	Q1
TPS7A7836PWPR	HTSSOP	PWP	14	3000	330.0	12.4	6.9	5.6	1.6	8.0	12.0	Q1
TPS7A7836PWPT	HTSSOP	PWP	14	250	330.0	12.4	6.9	5.6	1.6	8.0	12.0	Q1
TPS7A7850PWPR	HTSSOP	PWP	14	3000	330.0	12.4	6.9	5.6	1.6	8.0	12.0	Q1
TPS7A7850PWPT	HTSSOP	PWP	14	250	330.0	12.4	6.9	5.6	1.6	8.0	12.0	Q1

TAPE AND REEL BOX DIMENSIONS

*All dimensions are nominal

Device	Package Type	Package Drawing	Pins	SPQ	Length (mm)	Width (mm)	Height (mm)
TPS7A7833PWPR	HTSSOP	PWP	14	3000	356.0	356.0	35.0
TPS7A7833PWPT	HTSSOP	PWP	14	250	356.0	356.0	35.0
TPS7A7836PWPR	HTSSOP	PWP	14	3000	356.0	356.0	35.0
TPS7A7836PWPT	HTSSOP	PWP	14	250	356.0	356.0	35.0
TPS7A7850PWPR	HTSSOP	PWP	14	3000	356.0	356.0	35.0
TPS7A7850PWPT	HTSSOP	PWP	14	250	356.0	356.0	35.0

GENERIC PACKAGE VIEW

PWP 14

PowerPAD TSSOP - 1.2 mm max height

4.4 x 5.0, 0.65 mm pitch

PLASTIC SMALL OUTLINE

This image is a representation of the package family, actual package may vary.
Refer to the product data sheet for package details.

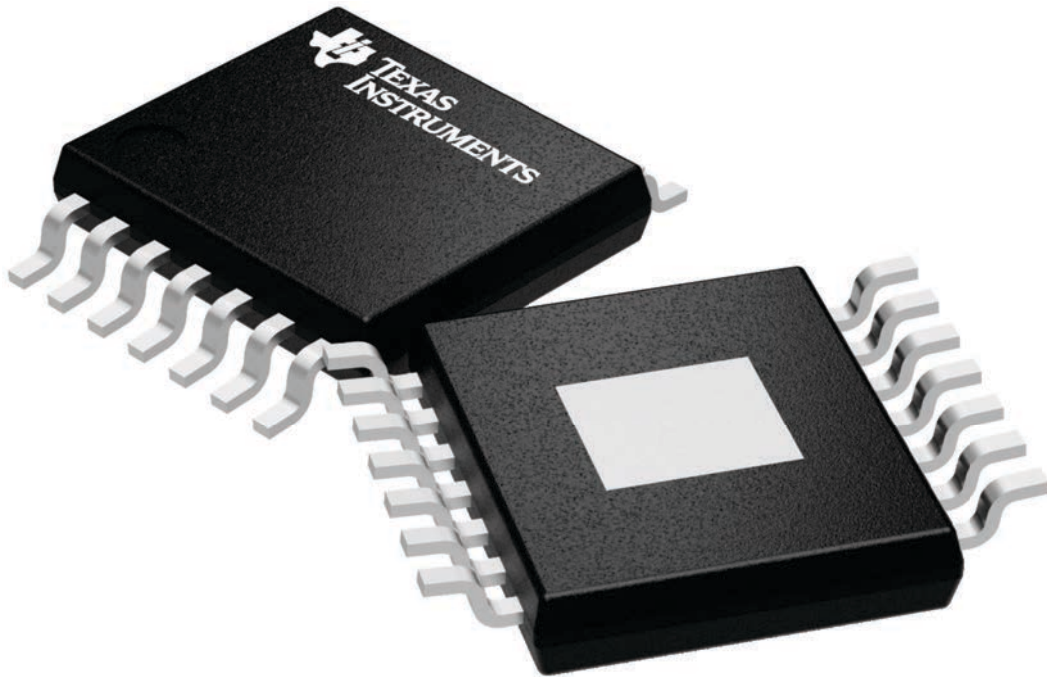

4224995/A

IMPORTANT NOTICE AND DISCLAIMER

TI PROVIDES TECHNICAL AND RELIABILITY DATA (INCLUDING DATA SHEETS), DESIGN RESOURCES (INCLUDING REFERENCE DESIGNS), APPLICATION OR OTHER DESIGN ADVICE, WEB TOOLS, SAFETY INFORMATION, AND OTHER RESOURCES "AS IS" AND WITH ALL FAULTS, AND DISCLAIMS ALL WARRANTIES, EXPRESS AND IMPLIED, INCLUDING WITHOUT LIMITATION ANY IMPLIED WARRANTIES OF MERCHANTABILITY, FITNESS FOR A PARTICULAR PURPOSE OR NON-INFRINGEMENT OF THIRD PARTY INTELLECTUAL PROPERTY RIGHTS.

These resources are intended for skilled developers designing with TI products. You are solely responsible for (1) selecting the appropriate TI products for your application, (2) designing, validating and testing your application, and (3) ensuring your application meets applicable standards, and any other safety, security, regulatory or other requirements.

These resources are subject to change without notice. TI grants you permission to use these resources only for development of an application that uses the TI products described in the resource. Other reproduction and display of these resources is prohibited. No license is granted to any other TI intellectual property right or to any third party intellectual property right. TI disclaims responsibility for, and you will fully indemnify TI and its representatives against, any claims, damages, costs, losses, and liabilities arising out of your use of these resources.

TI's products are provided subject to [TI's Terms of Sale](#) or other applicable terms available either on [ti.com](https://www.ti.com) or provided in conjunction with such TI products. TI's provision of these resources does not expand or otherwise alter TI's applicable warranties or warranty disclaimers for TI products.

TI objects to and rejects any additional or different terms you may have proposed.

Mailing Address: Texas Instruments, Post Office Box 655303, Dallas, Texas 75265
Copyright © 2024, Texas Instruments Incorporated