

## ABSTRACT

As many systems such as automated test and measurement and factory automation become smaller and more cost constrained, one potential for savings can come from shrinking the signal chain. Almost every system contains some type of switching and historically, mechanical relays were used. This implementation can be good from a performance perspective, but comes with a significant tradeoff on size, cost, and reliability. In more modern designs, Photorelays are often used instead of mechanical relays. These typically take a small hit on signal performance to drastically reduce size and cost while increasing reliability. Many systems can be further optimized by using TI's integrated **Flat On-Resistance Multiplexers** instead of Photorelays. In this application note, we go over the differences in performance, cost, size, and reliability between these three solutions.

Though these three devices can serve similar purposes, their internal designs are very different. Mechanical relays typically consist of an inductive coil and a physical switch. When current excites the coil, it becomes magnetic and pulls two pieces of metal together. Photorelays have a similar operation except instead of a coil, an LED is used to drive the gate of a MOSFET on/off. A multiplexer integrates multiple drivers and MOSFETs onto the same chip and drives the gate with a constant voltage source. As a result, Multiplexers save PCB space compared to Photorelay and mechanical relays.

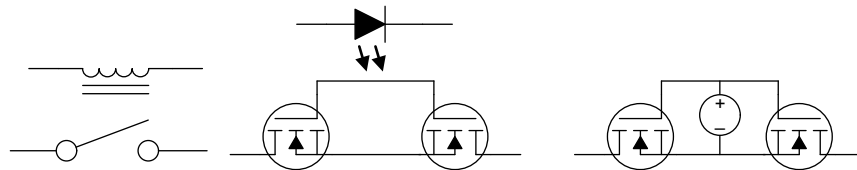

**Figure 1-1. Equivalent Circuits (from left to right): Mechanical Relay, Photorelay, Multiplexer**

## Table of Contents

<b>1</b>	<b>Size Requirement</b> .....	<b>3</b>
1.1	Optimized Layout and Control .....	4
<b>2</b>	<b>Reliability Over Time</b> .....	<b>4</b>
<b>3</b>	<b>Power Consumption</b> .....	<b>4</b>
<b>4</b>	<b>Switching Speed and Hot Switching</b> .....	<b>5</b>
<b>5</b>	<b>Signal Isolation</b> .....	<b>5</b>
<b>6</b>	<b>Capacitance</b> .....	<b>6</b>
<b>7</b>	<b>On-Resistance and Flatness</b> .....	<b>6</b>
<b>8</b>	<b>Leakage Current</b> .....	<b>7</b>
<b>9</b>	<b>Integrated Protection</b> .....	<b>7</b>
<b>10</b>	<b>Latch-up Immunity</b> .....	<b>7</b>
<b>11</b>	<b>Galvanic Isolation</b> .....	<b>7</b>
<b>12</b>	<b>Conclusion</b> .....	<b>8</b>
<b>13</b>	<b>References</b> .....	<b>8</b>
<b>14</b>	<b>Revision History</b> .....	<b>9</b>

## List of Figures

Figure 1-1.	Equivalent Circuits (from left to right): Mechanical Relay, Photorelay, Multiplexer .....	1
Figure 1-1.	16 Channel, 50V design Size Comparison (drawn to scale) .....	3
Figure 1-2.	TMUXS7614D top, TMUX7612/TMUX8212 middle, Photorelay Bottom .....	3
Figure 2-1.	Required Drive Strength Over Time .....	4
Figure 4-1.	Switching Profile Example (from top to bottom) Mechanical Relay, Photorelay, Multiplexer.....	5

Figure 5-1. MOSFET Simplified Capacitance Parasitics.....	5
Figure 5-2. Small Signal Off-Isolation Across Frequency .....	5
Figure 6-1. Off-isolation to Equivalent Capacitance Equations (Assumes a 50-ohm Impedance System) .....	6
Figure 7-1. On-Resistance of a Mechanical Relay, Photorelay, conventional Multiplexer, and TI's Flat Ron Multiplexer .....	6
Figure 8-1. Off-Leakage Current of a Photorelay, Conventional Multiplexer, and TI's Flat Ron Multiplexer .....	7

## **Trademarks**

All trademarks are the property of their respective owners.

## 1 Size Requirement

One of the largest benefits to an integrated multiplexer switching design is size. For example, in a 16-channel system, 16 SPST (1:1) mechanical relays would be needed, accounting for >450mm<sup>2</sup> board area. This is before including any relay driver ICs. Compare this to a Photorelay design and the user can see that the size requirements reduce dramatically. But Photorelays can not be driven directly through GPIO and need an LED driver to control the state of each switch. This adds to the design size and increases the system complexity, as well as power requirements. TI's Multiplexer design such as the [TMUX821x](#) and [TMUX7612](#) do not require any additional ICs. Each individual switch can be controlled by standard digital pins with [1.8V Logic](#). As a result, TI's switch design is even smaller than a comparable Photorelay design.

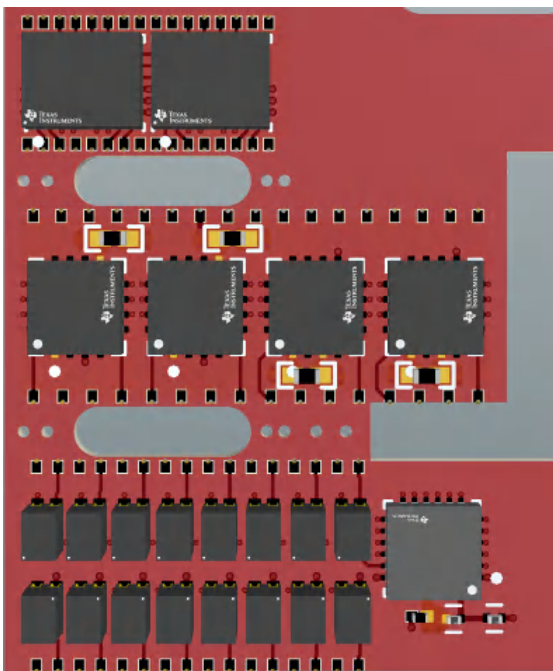

**Figure 1-1. 16 Channel, 50V design Size Comparison (drawn to scale)**

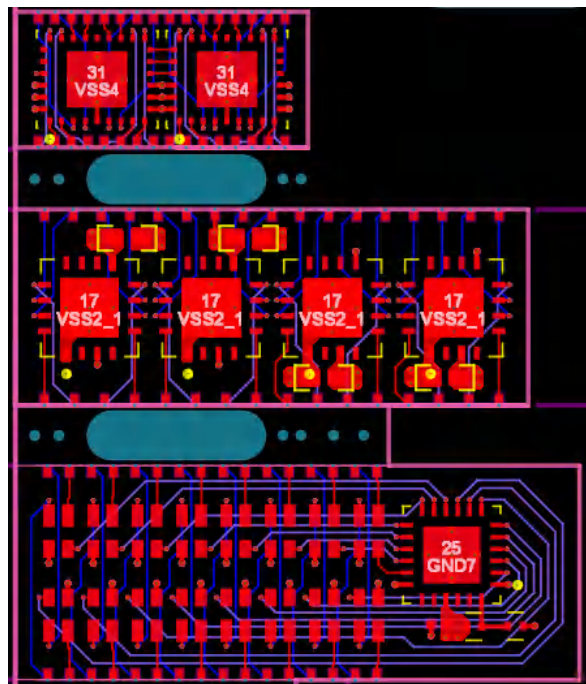

**Figure 1-2. TMUXS7614D top, TMUX7612/TMUX8212 middle, Photorelay Bottom**

As design size becomes a larger concern, routing and layout become a major consideration. The table below compares the actual design size of these three options with routing. You can see while the package density of the [TMUX7612](#) and Photorelay are similar, when routing and layout is considered the space savings is more significant. And the [TMUXS7614D](#) saves significantly more area on top of this by integrating the passive components and optimizing the pinout.

**Table 1-1. PCB Area Comparison for 16 channel design**

	TMUXS7614D	TMUX7612 TMUX8212	Photorelay
Total Package Area	2.5mm <sup>2</sup> /ch	4.0mm <sup>2</sup> /ch	4.2mm <sup>2</sup> /ch
Total PCB Area	3.18mm <sup>2</sup> /ch	9.13mm <sup>2</sup> /ch	11.22mm <sup>2</sup> /ch
Area Savings	129mm <sup>2</sup> (70% reduction)	33.5mm <sup>2</sup> (20% reduction)	-

## 1.1 Optimized Layout and Control

Another option you have with integrated multiplexers or switches is optimized layout and control. Most analog switches are GPIO CMOS input control which already has advantages over LED input controls like photorelays. But this can be further optimized with SPI controlled devices like the [TMUXS7614D](#). As seen in the previous example, if you are trying to control a 16 channel system, you normally need 16 GPIO controls or 16 LED drive channels for an analog switch and photorelay respectively. With a SPI controlled multiplexer, the control can be connected in daisy chain, meaning you only need 3 control lines (clock, data, chip select) to control all 16 channels independently. And this can be scaled up to any channel count, with only 3 control pins.

Additionally, the [TMUXS7614D](#) integrates the decoupling capacitors and has an optimized layout so the routing and placement can be done with minimal empty space around the switch. This enables a much higher effective channel density when routing is considered.

## 2 Reliability Over Time

Photorelays offer a clear improvement in reliability over mechanical relays, since there are no moving parts. Photorelays are controlled optically through an LED. Typically, this LED will degrade over time more quickly than the switch itself depending on temperature, forward current, switch speed, and so on. As the LED degrades, more current is needed to fully turn on the photorelay. This can necessitate system changes and increase system size to compensate for this reliability. TI multiplexer's reliability is not dependent on the drive strength of the control or switching frequency. As long as the voltage driving the multiplexer is above the threshold and within the operating conditions of the device, the switch will always turn on. This threshold voltage does not change over time, unlike the drive current of an LED.

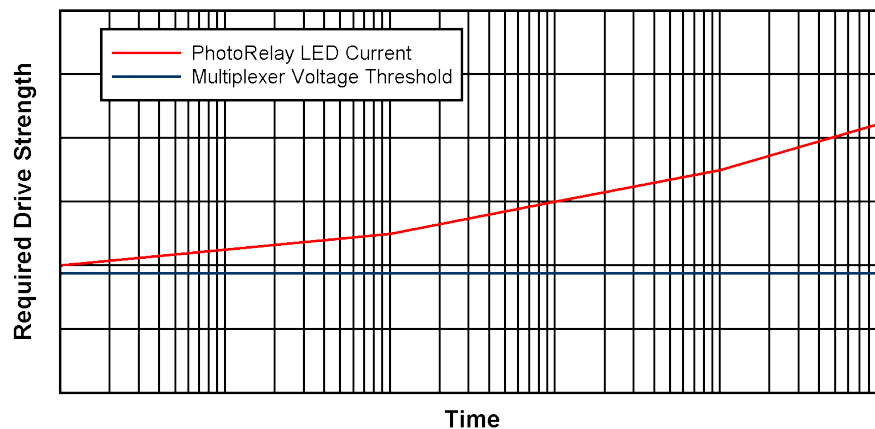

**Figure 2-1. Required Drive Strength Over Time**

Additionally, multiplexers will have additional ESD protection to protect the device during handling and assembly. Often, photorelays do not have this added integration and need external components to accomplish the same level of protection.

## 3 Power Consumption

Another key system requirement is power consumption. On a mechanical relay and a Photorelay device, the main power is consumed by the coil and the LED respectively. The current consumption can vary depending on the device and implementation, but typically 100mW/channel is needed to excite the coil on a mechanical relay. For a Photorelay, the LED typically needs 5mW/channel to fully turn on the switch. On a 4-channel multiplexer, the supply would consume <2.5mW per channel. So, in the 16-channel example shown in [Figure 1-1](#), the mechanical solution would use 1600mW, the Photorelay would use 80mW plus the power consumed by the LED driver, and the multiplexers would use <20mW. Using a multiplexer can dramatically reduce a system's power needs for portable and low power solutions.

## 4 Switching Speed and Hot Switching

Because Photorelays and Multiplexers are solid state devices with no moving parts, they do not have the issue of bouncing like mechanical relays. Bouncing occurs when a mechanical relay changes state. Because the switch is physical, there is a period where the switch bounces between the on and off state before settling. Additionally, Photorelay and Multiplexers can be hot switched (turned on/off when a voltage is present on the switch) with no impact to reliability for the same reason. In a mechanical relay, this hot switching can wear down or even weld the contactors causing severe issues with reliability.

Another key benefit of multiplexers is their much faster turn on/off time. Mechanical Relays turn on/off in the order of 1-10ms. Photorelays improve on this to about 0.1-1ms. Multiplexers improve even more to about 50-500us. This can increase operation speed and remove potential synchronization errors in the system. Another important performance difference is that Photorelay turn on/off time is dependent on the LED drive current. As the forward current on the LED increases, the turn off time increases. Multiplexers have no such dependency and switch at a constant speed regardless of the GPIO drive voltage.

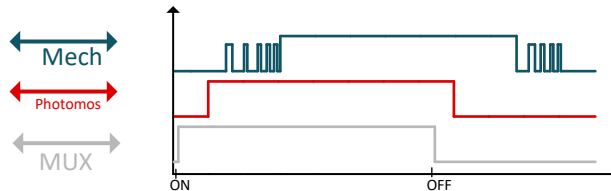

Figure 4-1. Switching Profile Example (from top to bottom) Mechanical Relay, Photorelay, Multiplexer

## 5 Signal Isolation

A key performance metric of any switch is how well it isolates signals across the switch when off. See the equivalent circuit diagram shown here [Figure 5-1](#). Ideally, the switch's off-resistance will be very high and the capacitance from input to output will be very low. When a signal is present on one side of the switch, we can calculate the ratio of output voltage to input voltage in dB across a frequency range. For Photorelay and multiplexer devices, Off-isolation performance is comparable across frequency but can vary depending on architecture. TI's Flat On-Resistance Multiplexers have a slight advantage due to an internal isolation shunt.

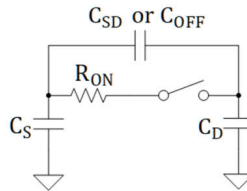

Figure 5-1. MOSFET Simplified Capacitance Parasitics

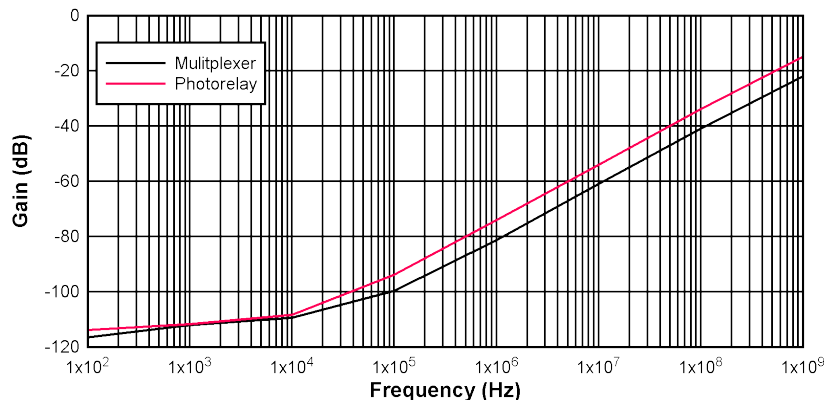

Figure 5-2. Small Signal Off-Isolation Across Frequency

## 6 Capacitance

For transient and AC systems, switch capacitance can impact signal quality. See [Figure 6-1](#). There are two main capacitive components of a MOSFET. The capacitance across the switch and the capacitance on the switch to ground. In many PhotoRelay data sheets, the capacitance across the switch is specified as Coff. This capacitance defines the AC isolation of the switch as a high pass filter. The larger this capacitance, the more AC voltage will be passed over the switch when off. It is also important to note that this capacitance is not flat across frequency, and typically increases at higher frequencies. For Multiplexer devices, this parameter is often not defined in the data sheets and instead, off-isolation is defined directly as the performance when the switch is off. But these values can be easily converted using [Figure 6-1](#).

$$C_{sd} = \sqrt{\frac{A^2}{w^2 R^2 (1-A^2)}} \quad \begin{matrix} A = 10^{OSIO/20} \\ w = 2\pi f \\ R = 50 \Omega \end{matrix} \quad OSIO = 20 \log_{10} \left( \frac{RCw}{\sqrt{1+(RCw)^2}} \right)$$

**Figure 6-1. Off-isolation to Equivalent Capacitance Equations (Assumes a 50-ohm Impedance System)**

The other key parasitic is the capacitance to ground on a multiplexer. This is described as Coff when the switch is off and Con when the switch is on in the data sheet. This capacitance defines the AC performance as a low-pass filter. The larger this capacitance, the more signals will be attenuated at high frequencies. In Photorelays, there is no direct ground reference. So, the equivalent to this capacitance is defined as total capacitance. Often times the key care about in a system is actually the RC of the switch. This is defined by the on-resistance and the capacitance multiplied together. Typically the lower the RC, the better the switch will perform at high speed.

## 7 On-Resistance and Flatness

One disadvantage many multiplexer devices have is On-Resistance. Because of the architecture of many multiplexer devices, the On-Resistance can vary significantly across bias voltage. This can result in large distortions on the output. However, TI's Flat On-Resistance family of multiplexers address this issue. These devices keep the On-Resistance flat across a wide bias range. As a result, the performance is more comparable to a Photorelay or mechanical relay. This Flat On-Resistance has significant benefits to system performance, reducing THD and ensuring signal integrity. These Flat On-Resistance multiplexers have extremely low distortion and bridge the performance gap to photorelays. An example of one of these TI multiplexers is the [TMUX821x](#).

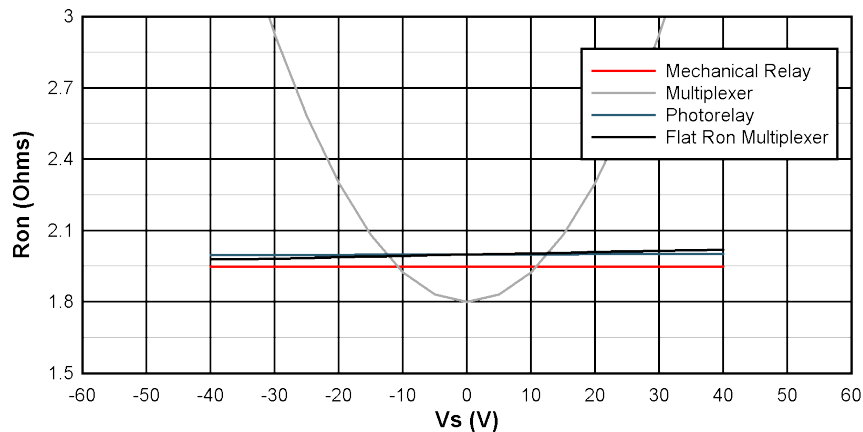
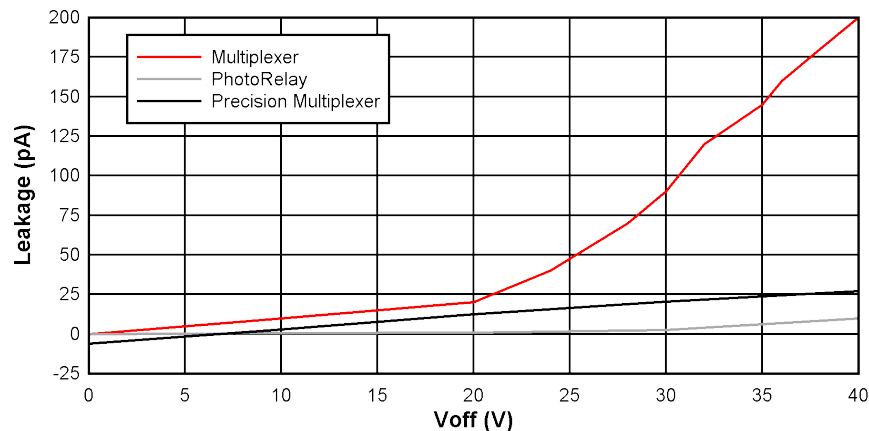

**Figure 7-1. On-Resistance of a Mechanical Relay, Photorelay, conventional Multiplexer, and TI's Flat Ron Multiplexer**

## 8 Leakage Current

One key performance metric in precision systems is leakage current. If a large voltage is applied across the switch when it is off, unwanted current can flow through the MOSFETs. Modern MOSFET designs have reduced this leakage significantly, but for some applications even a few picoamps can affect system performance.

This leakage is typically defined as  $I_{off}$  or off-leakage current. For a mechanical relay, this leakage would be essentially zero, as there is no path for the current to take other than through the insulator. In solid state solutions, the leakage current mostly comes from the Backgate of the MOSFETs. Because photorelays do not have a ground reference, the only path current can take is across the switch. In a Multiplexer, there is some amount of leakage current with respect to ground. TI's Flat Ron Multiplexer has reduced the leakage of the switch significantly compared to a conventional multiplexer. While not as low as Photorelays, these devices offer compelling performance given their integration.



**Figure 8-1. Off-Leakage Current of a Photorelay, Conventional Multiplexer, and TI's Flat Ron Multiplexer**

The final note to remember for leakage current, is temperature dependency.  $I_{off}$  increases exponentially across temperature. This behavior is true for both Photorelays and multiplexers. As a result, system temperature need to be kept as low as possible for precision applications, ideally below 50°C.

## 9 Integrated Protection

Because multiplexers are integrated ICs, they often will incorporate additional features that are not found on mechanical relays or Photorelays. One example of this is overvoltage protection, where the switch will automatically open if an overvoltage event is detected. This can be extremely useful in harsh industrial environments to protect sensitive ICs downstream. For more information see the [TMUX741x](#) and [Improving Analog Input Modules Reliability Using Fault Protected Multiplexers](#)

## 10 Latch-up Immunity

The likelihood of a latch-up event occurring increases in integrated analog multiplexers because of the smaller feature size and higher density placement of transistors. This is particularly true for devices that operate in harsh environments susceptible to overvoltage spikes, transients, and current injection. In these environments we recommend a latch-up immune multiplexer using processes such as silicon on insulator (SOI). For more information see [Using Latch-Up Immune Multiplexers to Help Improve System Reliability](#)

## 11 Galvanic Isolation

Photorelays and mechanical relays are electrically isolated from the switch path, therefore these two controls can be on separate domains based on their isolation voltage rating. In applications which do not require isolation between the control signals, a multiplexer may be used. In systems where isolation is needed, TI offers [solid state relay \(SSR\) solutions](#) such as the [TPSI3050-Q1](#) isolated switch driver.

## 12 Conclusion

Though mechanical and Photorelays can be the conventional choice for many switching applications, TI's integrated multiplexers have many strong advantages with minimal tradeoffs such as: a much smaller design size, excellent reliability, low power consumption, and fast switching speeds. Though it is important to consider the tradeoffs when it comes to leakage current, on-resistance flatness, and capacitance, as they relate to the system requirements. TI's Flat On-Resistance multiplexers have bridged this gap significantly offering lower leakage currents and flatness, while integrating Latch-up immunity and overvoltage protection.

**Table 12-1. Photorelay Replacement Recommended Devices**

	Signal Range	Package Channel Density	Leakage	On-Resistance Off-Capactiance	Features
TMUXS7614DZEMR	4.5 V to 42 V ±4.5 V to ±25 V	2.5mm <sup>2</sup> /ch	930 pA Ioff at 32.5V, 50C	1.3 Ω 27 pF	<ul style="list-style-type: none"> <li>Integrated passives and decoupling capacitors</li> <li>SPI control with daisy chain</li> <li>Optimized layout/pinout</li> </ul>
TMUX7612RUMR	4.5 V to 50 V ±4.5 V to ±25 V	4.0mm <sup>2</sup> /ch	930 pA Ioff at 32.5V, 50C	1.3 Ω 27 pF	<ul style="list-style-type: none"> <li>Over Temperature protection</li> </ul>
TMUX8212RUMR	10 V to 100 V ±10 V to ±55 V	4.0mm <sup>2</sup> /ch	4 nA Ioff at 95V, 85C	5 Ω 12 pF	<ul style="list-style-type: none"> <li>-102 dB THD+N</li> </ul>
TMUX7412FRRPR	8 V to 44 V ±5 V to ±22 V	4.0mm <sup>2</sup> /ch	2 nA Ioff at 30V, 85C	8.3 Ω 12 pF	<ul style="list-style-type: none"> <li>±60 V Overvoltage and power off protection</li> </ul>
TMUX6112RTER	10 V to 17 V ±8 V to ±17 V	2.25mm <sup>2</sup> /ch	140 pA Ioff at 10V, 85C	120 Ω 3 pF	-
TMUX1112RSVR	1.08 V to 5.5 V	0.6mm <sup>2</sup> /ch	300 pA Ioff at 10V, 85C	2 Ω 10 pF	-

## 13 References

- Texas Instrument, [TMUX821x 100-V, Flat Ron, 1:1 \(SPST\), 4-Channel Switches with Latch-Up Immunity and 1.8-V Logic](#) data sheet
- Texas Instrument, [TMUX741xF ±60 V Fault-protected, 1:1 \(SPST\), 4-Channel Switches with 1.8-V Logic](#) data sheet
- Texas Instrument, [TMUX7462F ±60 V Fault-Protected, Latch-Up Immune, Quad Channel Protector with Adjustable Fault Threshold and 1.8-V Logic](#) data sheet
- Texas Instrument, [1.8 V Logic for Muxes and Signal Switches](#)
- Texas Instrument, [Using Latch-Up Immune Multiplexers to Help Improve System Reliability](#)
- Texas Instrument, [Improving Analog Input Modules Reliability Using Fault Protected Multiplexers](#)



## 14 Revision History

<b>Changes from Revision * (May 2022) to Revision A (June 2024)</b>	<b>Page</b>
• Updated the numbering format for tables, figures, and cross-references throughout the document .....	<a href="#">1</a>
• Added information on SPI control, PCB area and performance of TMUXS7614D .....	<a href="#">3</a>
• Updated key device recommendation table .....	<a href="#">8</a>

## IMPORTANT NOTICE AND DISCLAIMER

TI PROVIDES TECHNICAL AND RELIABILITY DATA (INCLUDING DATA SHEETS), DESIGN RESOURCES (INCLUDING REFERENCE DESIGNS), APPLICATION OR OTHER DESIGN ADVICE, WEB TOOLS, SAFETY INFORMATION, AND OTHER RESOURCES "AS IS" AND WITH ALL FAULTS, AND DISCLAIMS ALL WARRANTIES, EXPRESS AND IMPLIED, INCLUDING WITHOUT LIMITATION ANY IMPLIED WARRANTIES OF MERCHANTABILITY, FITNESS FOR A PARTICULAR PURPOSE OR NON-INFRINGEMENT OF THIRD PARTY INTELLECTUAL PROPERTY RIGHTS.

These resources are intended for skilled developers designing with TI products. You are solely responsible for (1) selecting the appropriate TI products for your application, (2) designing, validating and testing your application, and (3) ensuring your application meets applicable standards, and any other safety, security, regulatory or other requirements.

These resources are subject to change without notice. TI grants you permission to use these resources only for development of an application that uses the TI products described in the resource. Other reproduction and display of these resources is prohibited. No license is granted to any other TI intellectual property right or to any third party intellectual property right. TI disclaims responsibility for, and you will fully indemnify TI and its representatives against, any claims, damages, costs, losses, and liabilities arising out of your use of these resources.

TI's products are provided subject to [TI's Terms of Sale](#) or other applicable terms available either on [ti.com](https://www.ti.com) or provided in conjunction with such TI products. TI's provision of these resources does not expand or otherwise alter TI's applicable warranties or warranty disclaimers for TI products.

TI objects to and rejects any additional or different terms you may have proposed.

Mailing Address: Texas Instruments, Post Office Box 655303, Dallas, Texas 75265  
Copyright © 2024, Texas Instruments Incorporated