



ABSTRACT

This document is the EVM user's guide for the TMUXBQB-DYEEVM, which provides a quick way to evaluate TI devices that use a 16-pin BQB, DYY or PW package.

Table of Contents

1 Introduction	2
2 Information About Cautions and Warnings	5
3 Features	5
4 TMUXBQB-DYEEVM Header Connections and Test Points	6
5 TMUXBQB-DYEEVM Setup	9
6 Layout	11
7 Schematics	12
8 Bill of Materials	16

List of Figures

Figure 1-1. TMUXBQB-DYEEVM Top View.....	2
Figure 1-2. TMUXBQB-DYEEVM Bottom View.....	3
Figure 1-3. TMUXBQB-DYEEVM 3D View.....	4
Figure 4-1. Header J3 for U1.3.....	6
Figure 4-2. Pinout of Headers.....	6
Figure 4-3. Test Point Colors.....	7
Figure 5-1. DUT Footprint U1.....	9
Figure 5-2. Signal Line Circuitry (3D).....	9
Figure 5-3. Signal Line Circuitry.....	10
Figure 5-4. Signal Line Circuitry Bottom Layer.....	10
Figure 6-1. Illustration of TMUXBQB-DYEEVM Layout.....	11
Figure 7-1. TMUXBQB-DYEEVM Schematic Page 1 (Editor View).....	12
Figure 7-2. TMUXBQB-DYEEVM Schematic Page 2 (Editor View).....	13
Figure 7-3. TMUXBQB-DYEEVM Schematic Page 1 (DNI).....	14
Figure 7-4. TMUXBQB-DYEEVM Schematic Page 2 (DNI).....	15

List of Tables

Table 4-1. Connections by Header Pin Number.....	7
Table 4-2. Test Point Connections.....	7
Table 8-1. TMUXBQB-DYEEVM Bill of Materials.....	16

Trademarks

All trademarks are the property of their respective owners.

1 Introduction

This user's guide describes the TMUXBQB-DYEEVM evaluation module (EVM) and its intended use. This board allows for the quick prototyping and DC characterization of TI's line of TMUX products that use 16-pin TSSOP (PW), WQFN (BQB) and SOT-23 THIN (DYY) packages.

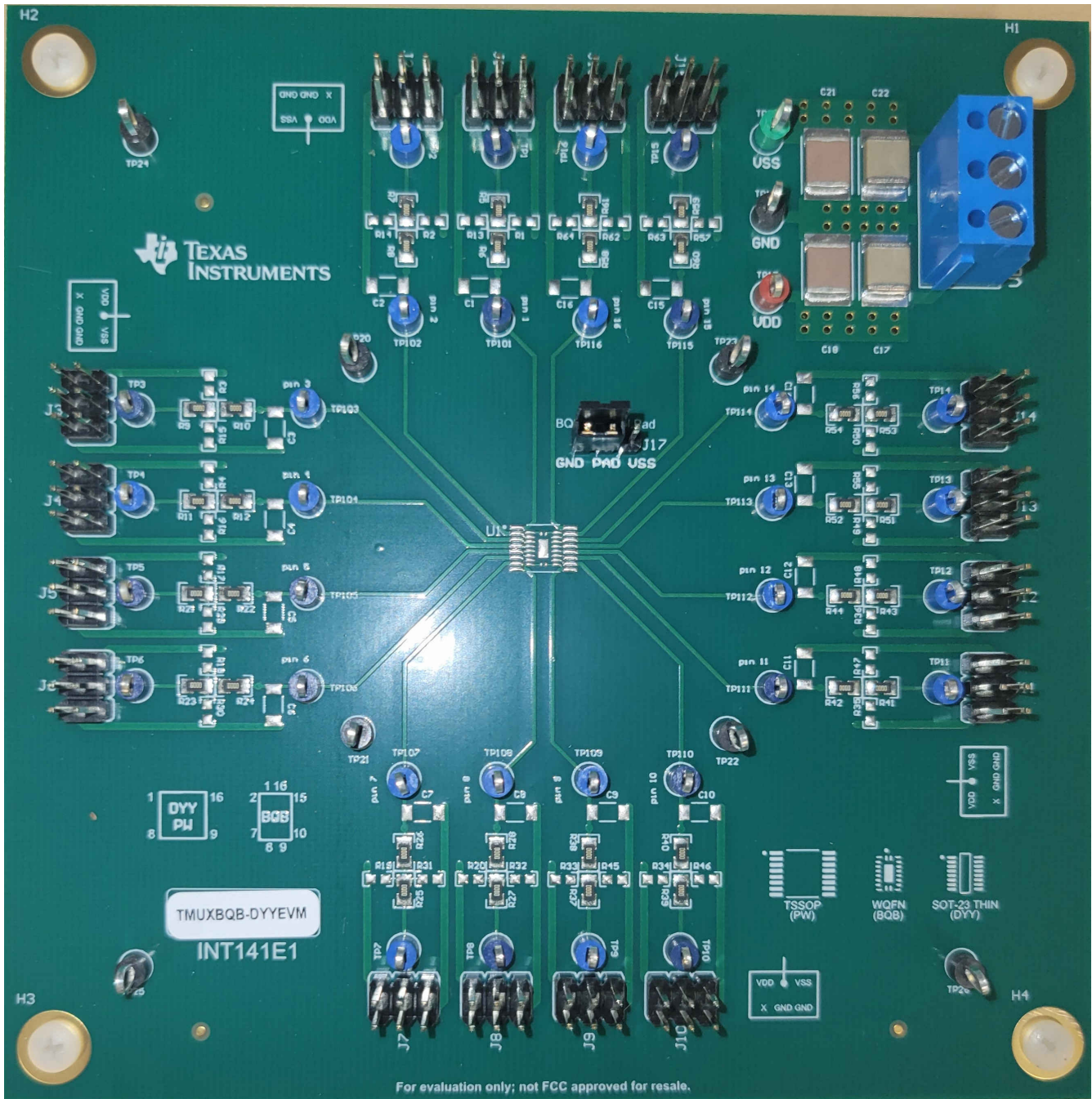

Figure 1-1. TMUXBQB-DYEEVM Top View

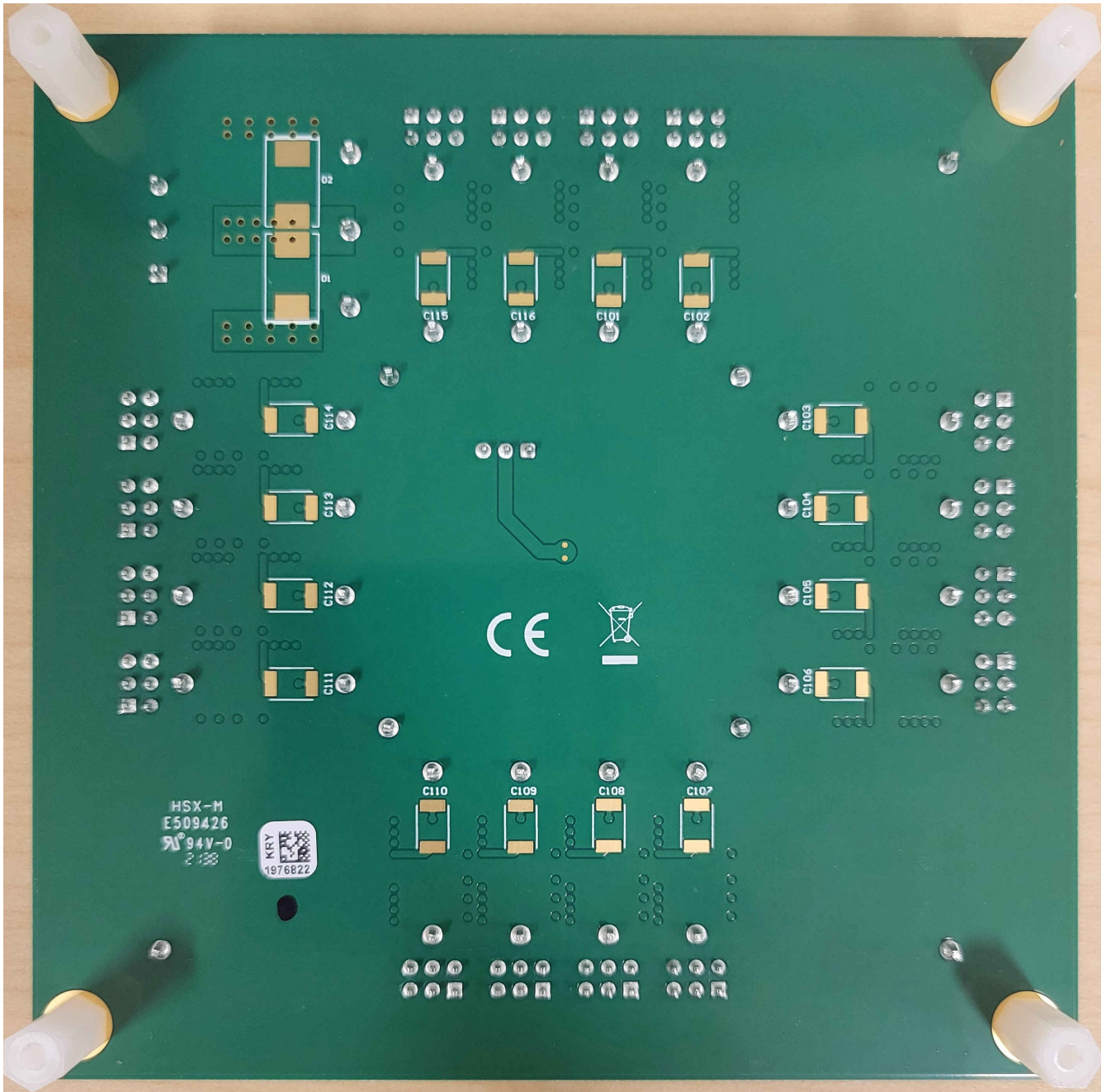

Figure 1-2. TMUXBQB-DYEEVM Bottom View

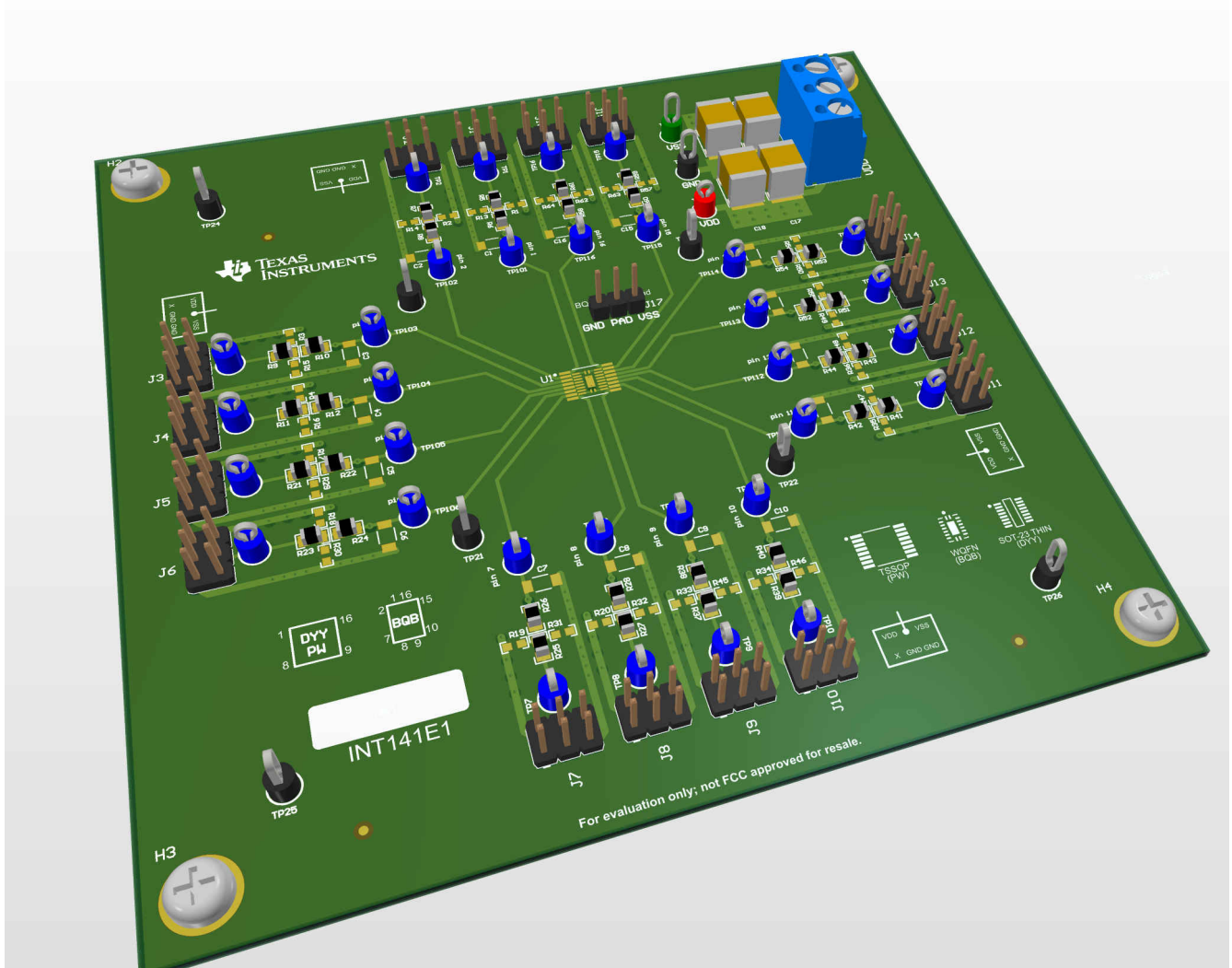

Figure 1-3. TMUXBQB-DYYEVM 3D View

2 Information About Cautions and Warnings

The information in the warning statement is provided for personal protection and the information in the caution statement is provided to protect the equipment from damage. Read each caution and warning statement carefully.



CAUTION

This EVM contains components that can potentially be damaged by electrostatic discharge. Always transport and store the EVM in its supplied ESD bag when not in use. Handle using an antistatic wristband. Operate on an antistatic work surface. For more information on proper handling, see [Electrostatic Discharge \(ESD\)](#).

3 Features

The TMUXBQB-DYYEVM has the following features:

- 2 power supply decoupling capacitors from VDD to GND (1 × 1 μF; 1 × 0.1 μF)
- 1 protection diode pad from VDD to GND available near power supply (6.9 mm × 5.8 mm)
- 2 power supply decoupling capacitors from VSS to GND (1 × 1 μF; 1 × 0.1 μF)
- 1 protection diode pad from VSS to GND available near power supply (6.9 mm × 5.8 mm)
- Terminal block power supply connection
- DUT footprint compatible with 16-pin PW (TSSOP), WQFN (BQB), and SOT-23 THIN (DYY) packages
- 16 length-matched signal inputs corresponding to the 24 pins of the DUT
- Selectable connections to VDD, VSS, or GND for each signal input using 2.54 mm shunt
- Footprints for pull-up and pull-down resistors for each signal input (2 × 0603 footprint on each of 16 signals)
- Footprints for series resistors for each signal input (2 × 0805 footprint on each of 16 signals)
- Footprints for decoupling capacitors for each input (1 × 1206 footprint and 1 × 1812 footprint on each of 16 signals)
- 2 test points for each signal input
- Multiple GND test point connections around board

4 TMUXBQB-DYEEVM Header Connections and Test Points

There are 16 headers located around the board with designators J1 through J16. These 3-by-2 headers serve as connections to power planes and to signals of the DUT (U1). Each pin of the DUT has similar header and test point configuration. At four different locations around the board, a legend shows the connections of the pins of the nearby five headers. [Figure 4-1](#) shows a representation of the header associated with pin 3 of U1.

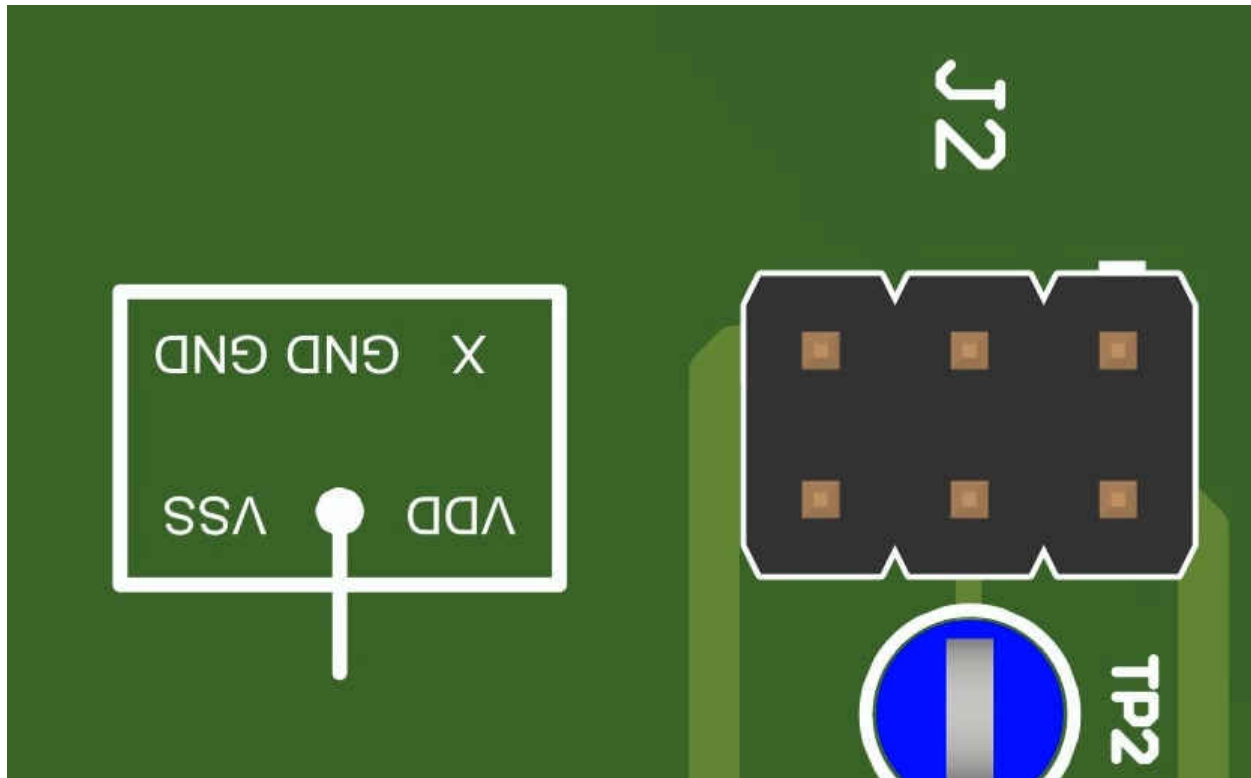

Figure 4-1. Header J3 for U1.3

The silkscreen legend represents the connections of the pins of J2. [Figure 4-2](#) shows the pin numbers of this header from this same perspective.



Figure 4-2. Pinout of Headers

[Table 4-1](#) also shows the connections.

Table 4-1. Connections by Header Pin Number

Header pin number	Connection
1	No connection
2	VDD
3	GND
4	U1
5	GND
6	VSS

For all headers J1 through J16, the connections are the same, but are rotated by a multiple of 90° according to their position on the board. A legend is included for each rotation.

In addition to headers, multiple test points are located around the board. Black test points (TP18 and TP20-TP26) are connected to GND, the red test point (TP17) is connected to VDD, and the green test point (TP19) is connected to VSS. The remaining blue test points (TP1-TP16 and TP101-TP116) are connected along the signal paths of the pins of U1.

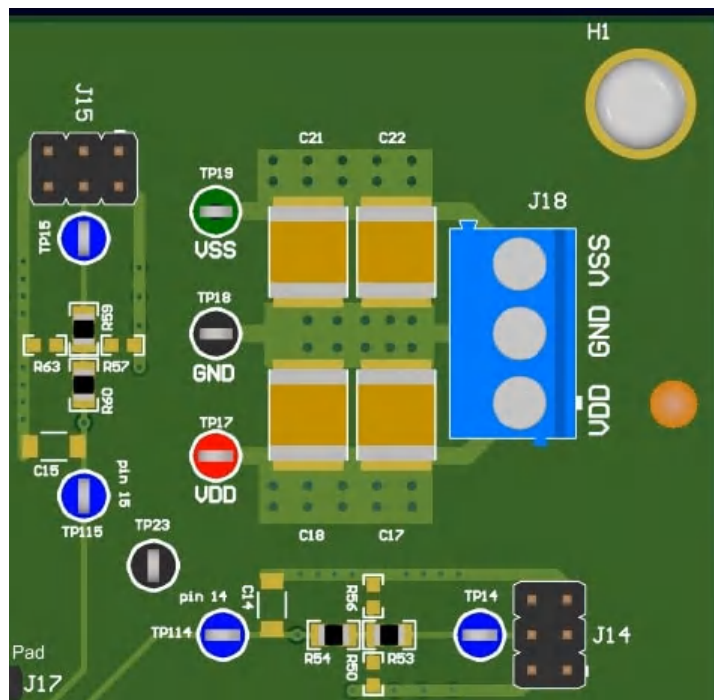

Figure 4-3. Test Point Colors

Table 4-2 shows the test point connections.

Table 4-2. Test Point Connections

Designator	Connection
TP1	J1.4
TP2	J2.4
TP3	J3.4
TP4	J4.4
TP5	J5.4
TP6	J6.4
TP7	J7.4
TP8	J8.4

Table 4-2. Test Point Connections (continued)

Designator	Connection
TP9	J9.4
TP10	J10.4
TP11	J11.4
TP12	J12.4
TP13	J13.4
TP14	J14.4
TP15	J15.4
TP16	J16.4
TP17	VDD
TP18	GND
TP19	VSS
TP20	GND
TP21	GND
TP22	GND
TP23	GND
TP24	GND
TP25	GND
TP26	GND
TP101	U1.1
TP102	U1.2
TP103	U1.3
TP104	U1.4
TP105	U1.5
TP106	U1.6
TP107	U1.7
TP108	U1.8
TP109	U1.9
TP110	U1.10
TP111	U1.11
TP112	U1.12
TP113	U1.13
TP114	U1.14
TP115	U1.15
TP116	U1.16

Terminal block J18 is the power input for the board. Three power rails (VSS, GND, and VDD) are labeled on the board's silkscreen layer, indicating the identities of the input pins of the header. Connect the power supply rails at this terminal block to power the board.

5 TMUXBQB-DYEEVM Setup

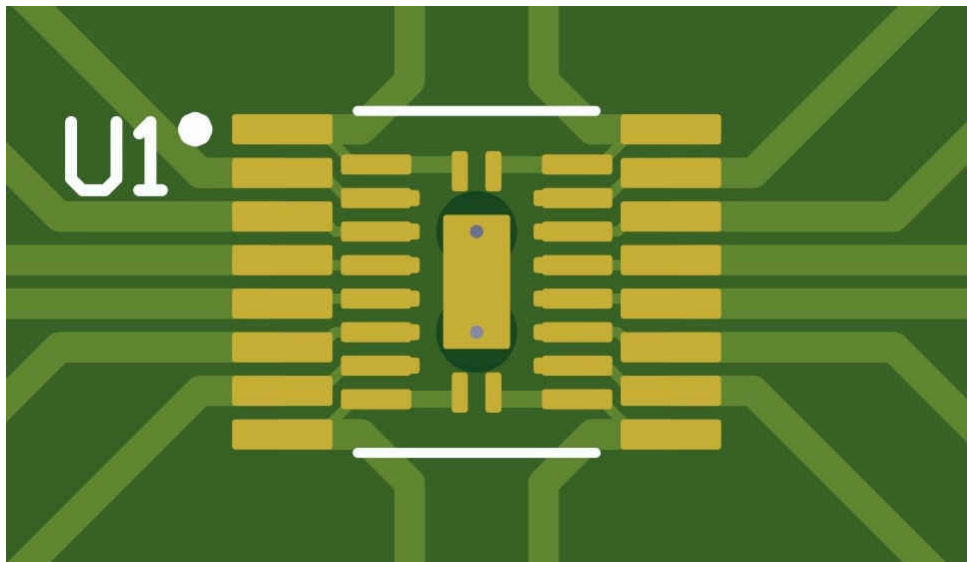

Figure 5-1. DUT Footprint U1

The TMUXBQB-DYEEVM will not have any device connected at footprint U1, and there are not any devices included with the EVM for this footprint. Attach any compatible Texas Instruments TMUX device to this location, which will serve as the Device Under Test (DUT). Compatible devices include 16-pin parts with PW, BQB or DYY package names.

The headers of the TMUXBQB-DYEEVM can be easily connected to a power rail using 2.54 mm shunts on J1-J16, not included with the board. Connecting the shunt between pin 4 of the header and pin 3 (GND) to connect the corresponding pin of U1 to GND. Alternatively, the pins of U1 can be shorted to VDD or VSS by connecting between pin 4 of the header and pin 2 or pin 6 respectively. [Figure 4-2](#) and [Table 4-1](#) includes detailed descriptions of the connections on J1 through J16.

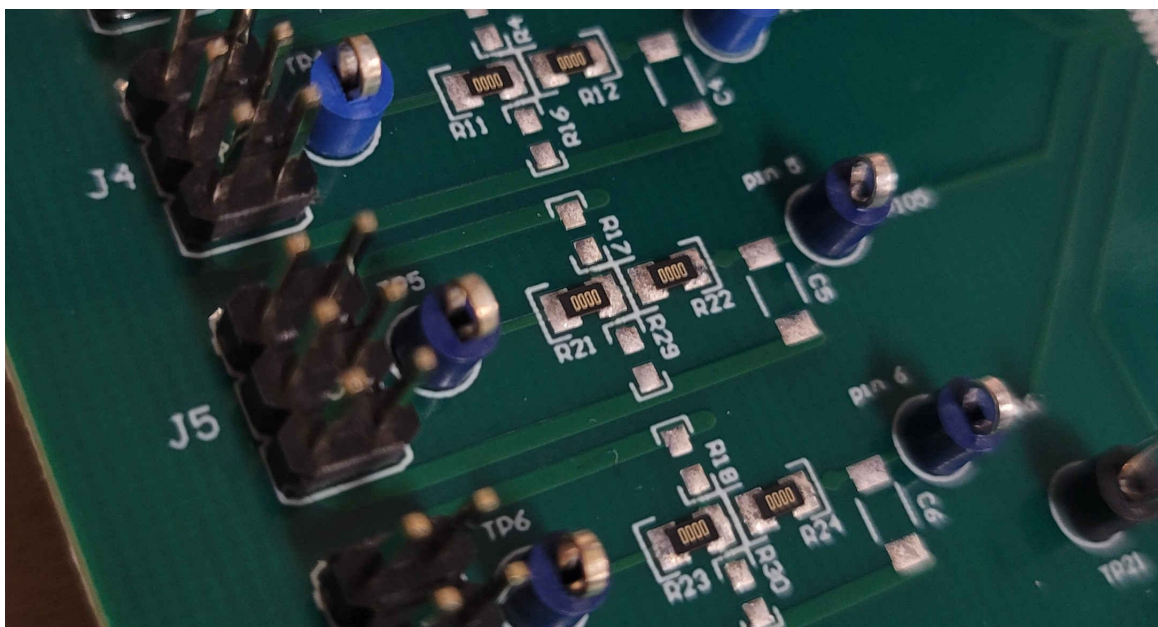

Figure 5-2. Signal Line Circuitry (3D)

As shown in [Figure 5-2](#) and [Figure 5-3](#) as R21 and R22 on the J5 (pin 5 of U1) signal line, the TMUXBQB-DYEEVM includes 0 Ω series resistors (0805 package) on each signal line.

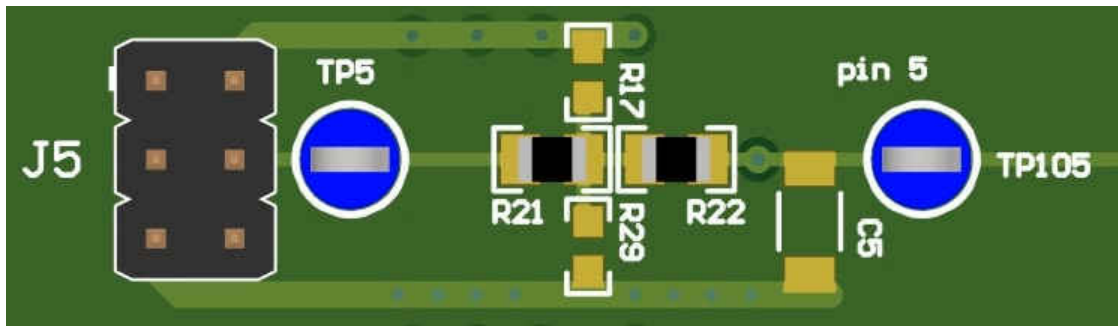

Figure 5-3. Signal Line Circuitry

These can be substituted for different resistors as desired. Additionally, there are pads for pull-up and pull-down resistors to VDD and GND respectively. Add any 0603 resistor to the footprint shown as R17 to provide pull-up to VDD, and add any 0603 resistor to the footprint shown as R29 to provide pull-down to GND.

Each signal line also includes two footprints that allow for the user to attach capacitors or other devices with matching footprints. On the top side of the board, shown in [Figure 5-2](#) and [Figure 5-3](#) as C5, a standard 1206 footprint exists between the U1 pin signal and the GND signal. The user can solder a capacitor to this footprint to provide capacitance to the signal line.

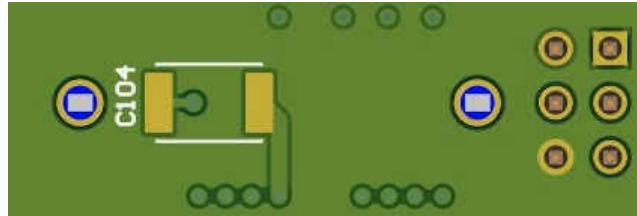

Figure 5-4. Signal Line Circuitry Bottom Layer

On the back side of the board, shown in [Figure 5-4](#) as C104, a standard 1812 footprint exists, also allowing for connection of a capacitor between the U1 pin signal and GND. The user can solder a capacitor to this footprint to provide capacitance to the signal line.

6 Layout

Figure 6-1 shows the layout of the EVM PCB.

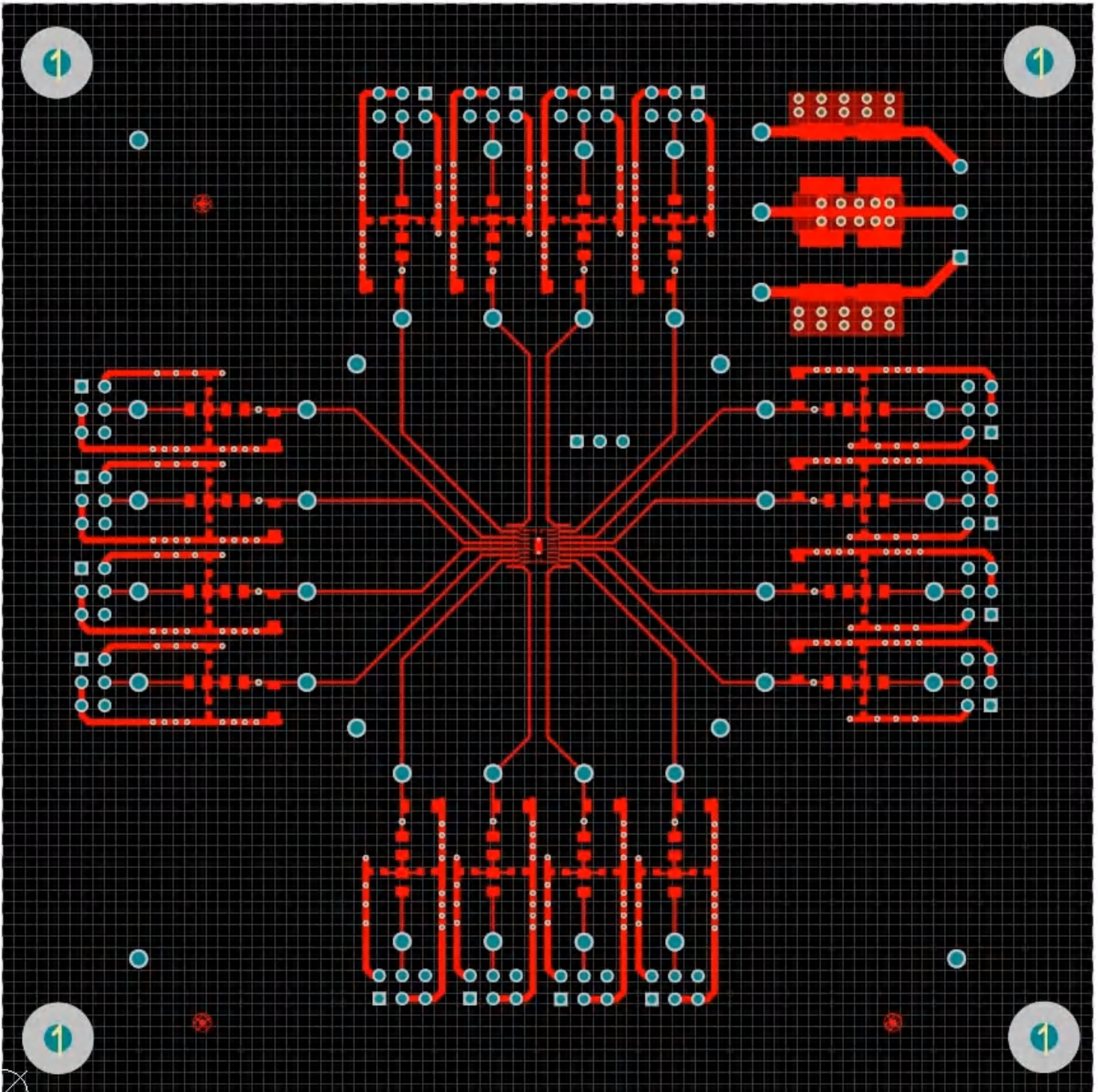

Figure 6-1. Illustration of TMUXBQB-DYYEVM Layout

7 Schematics

Figure 7-1 and Figure 7-2 are schematic views of the TMUXBQB-DYEEVM that includes all the parts and connections.

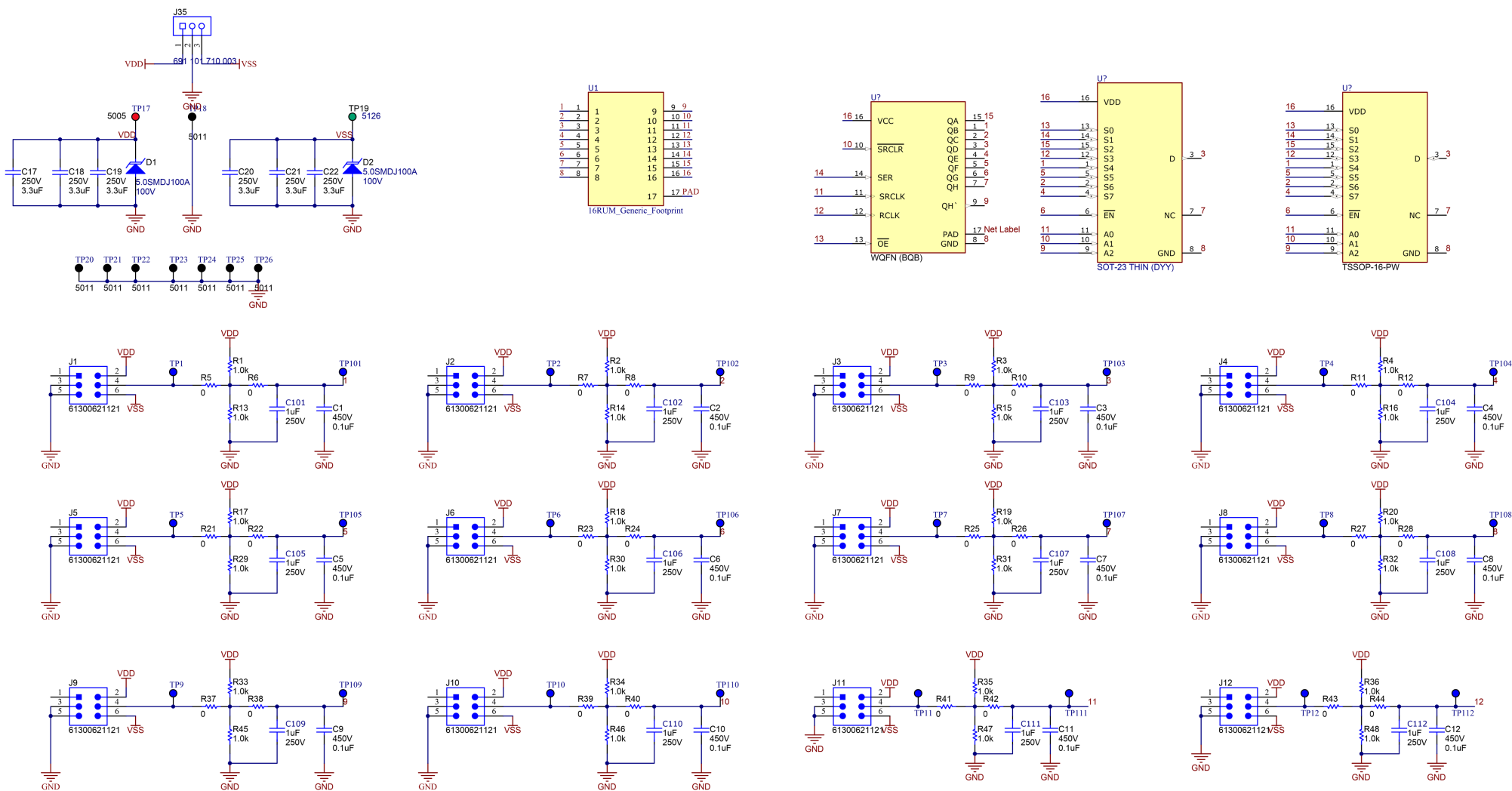

Figure 7-1. TMUXBQB-DYEEVM Schematic Page 1 (Editor View)

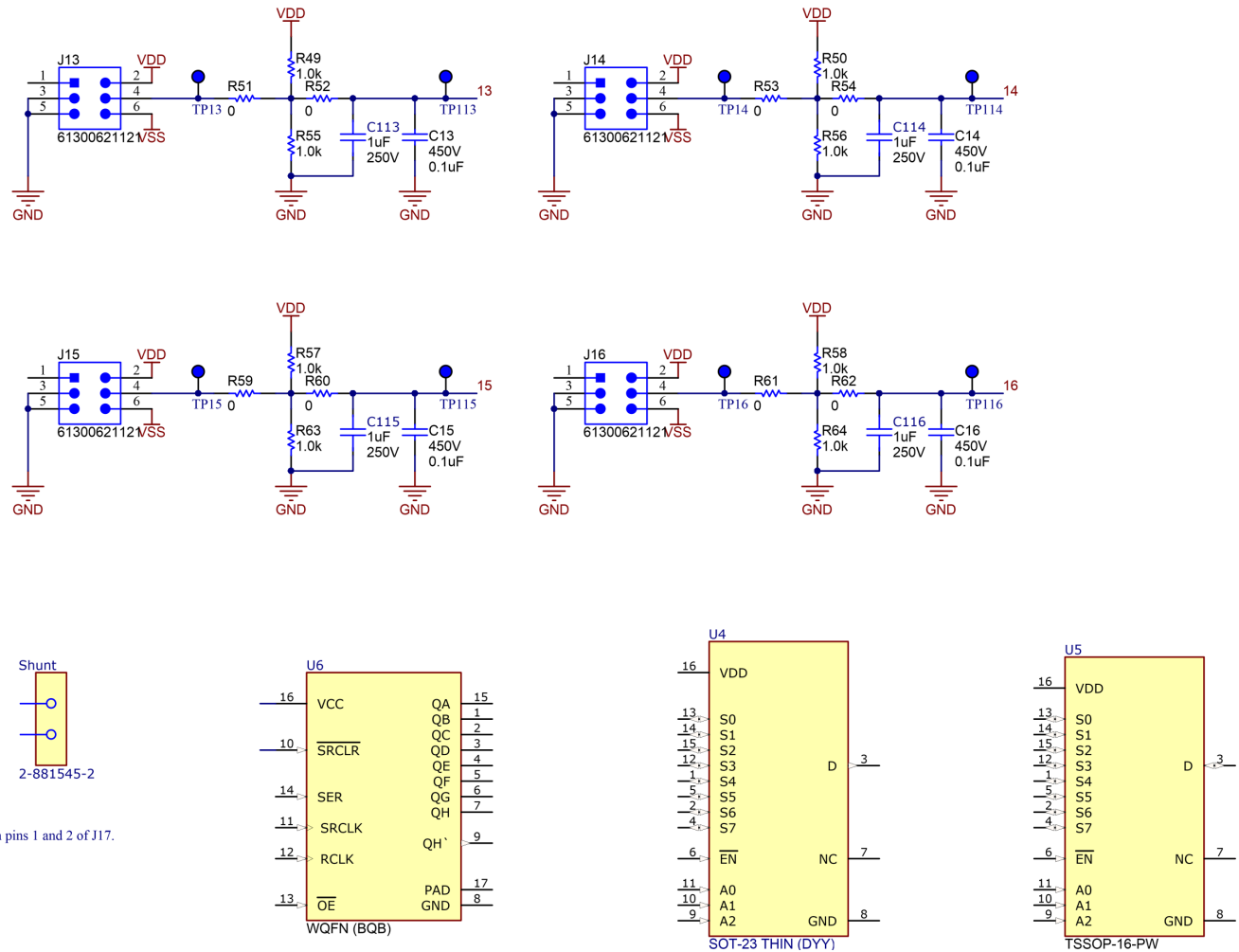

Figure 7-2. TMUXBQB-DYEEVM Schematic Page 2 (Editor View)

Figure 7-3 and Figure 7-4 are schematic views of the TMUXBQB-DYEEVM that show only the parts that are included in the EVM and excludes the parts that are DNI.

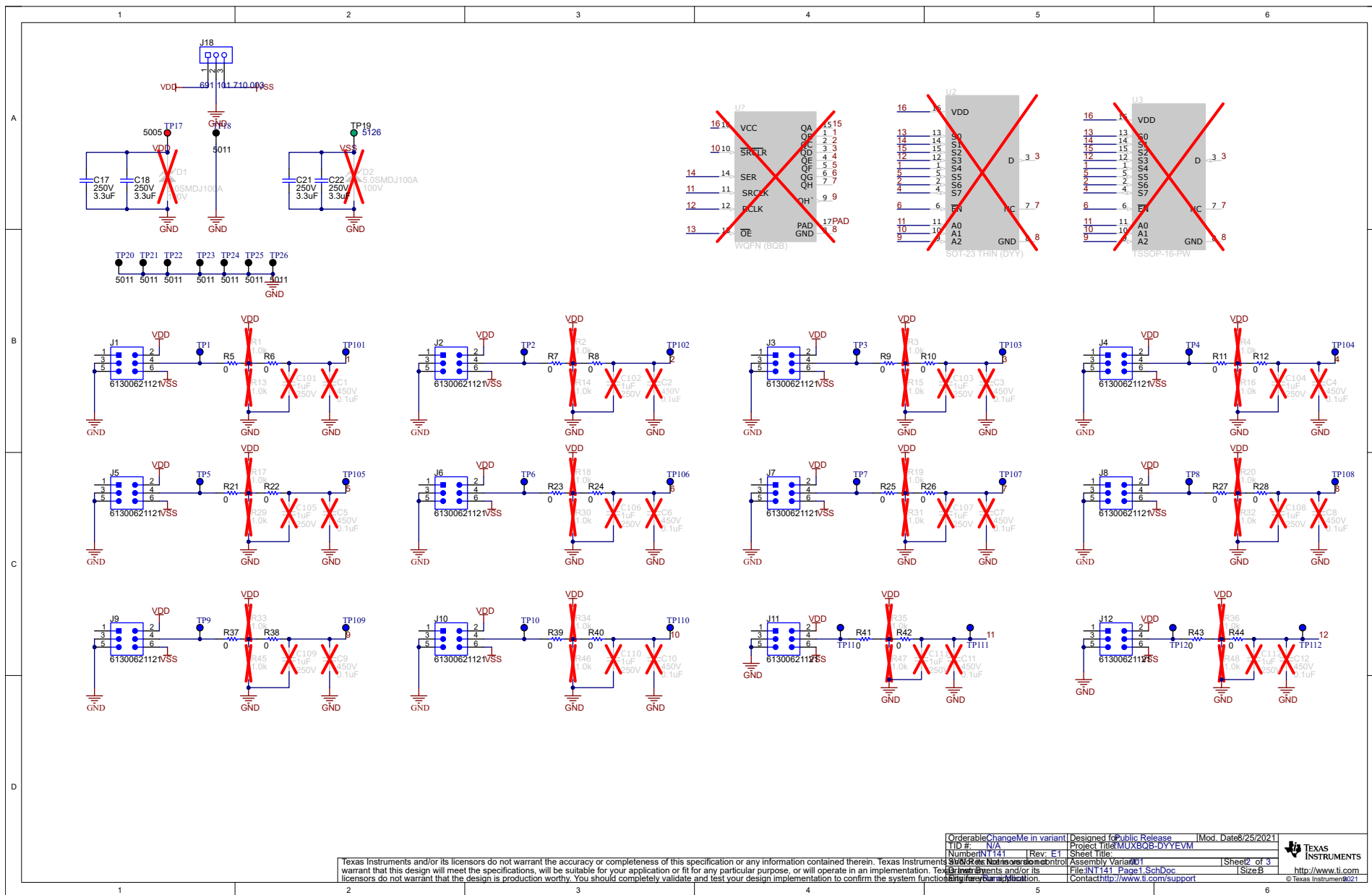

Figure 7-3. TMUXBQB-DYEEVM Schematic Page 1 (DNI)

8 Bill of Materials

Table 8-1. TMUXBQB-DYEEVM Bill of Materials

Designator	Component	Manufacturer	Description	Quantity
C18, C21	C2220C104J1GACTU	Kemet	Multilayer Ceramic Capacitors MLCC - SMD/SMT 100V 0.1 μ F C0G 2220 5%	2
C17, C22	C2220C105K1RACTU	Kemet	Multilayer Ceramic Capacitors MLCC - SMD/SMT 100V 1 μ F X7R 2220 10%	2
H1, H2, H3, H4	NY PMS 440 0025 PH	B&F Fastener Supply	Machine Screw, Round, #4-40 x 1/4, Nylon, Philips panhead	4
H5, H6, H7, H8	1902C	Keystone	Standoff, Hex, 0.5	4
J1, J2, J3, J4, J5, J6, J7, J8, J9, J10, J11, J12, J13, J14, J15, J16	61300621121	Würth Elektronik	Header, 2.54 mm, 3x2, Gold, TH	16
J17	61300311121	Würth Elektronik	Header, 2.54 mm, 3x1, Gold, TH	1
J18	691 101 710 003	Würth Elektronik	Terminal Block, 5 mm, 3x1, Tin, TH	1
LBL1	THT-14-423-10	Brady	Thermal Transfer Printable Labels, 0.650	1
R5, R6, R7, R8, R9, R10, R11, R12, R21, R22, R23, R24, R25, R26, R27, R28, R37, R38, R39, R40, R41, R42, R43, R44, R51, R52, R53, R54, R59, R60, R61, R62	PMR10EZPJ000	Rohm	RES, 0, 0%, W, AEC-Q200 Grade 0, 0805	32
Shunt	2-881545-2	TE	Default shunt positioning: between pins 1 and 2 of J17.	1
TP1, TP2, TP3, TP4, TP5, TP6, TP7, TP8, TP9, TP10, TP11, TP12, TP13, TP14, TP15, TP16, TP101, TP102, TP103, TP104, TP105, TP106, TP107, TP108, TP109, TP110, TP111, TP112, TP113, TP114, TP115, TP116	5122	Keystone	Test Point, Compact, Blue, TH	32
TP17	5005	Keystone	Test Point, Compact, Red, TH	1
TP18, TP20, TP21, TP22, TP23, TP24, TP25, TP26	5011	Keystone	Test Point, Multipurpose, Black, TH	8
TP19	5126	Keystone	Test Point, Multipurpose, Green, TH	1

IMPORTANT NOTICE AND DISCLAIMER

TI PROVIDES TECHNICAL AND RELIABILITY DATA (INCLUDING DATA SHEETS), DESIGN RESOURCES (INCLUDING REFERENCE DESIGNS), APPLICATION OR OTHER DESIGN ADVICE, WEB TOOLS, SAFETY INFORMATION, AND OTHER RESOURCES "AS IS" AND WITH ALL FAULTS, AND DISCLAIMS ALL WARRANTIES, EXPRESS AND IMPLIED, INCLUDING WITHOUT LIMITATION ANY IMPLIED WARRANTIES OF MERCHANTABILITY, FITNESS FOR A PARTICULAR PURPOSE OR NON-INFRINGEMENT OF THIRD PARTY INTELLECTUAL PROPERTY RIGHTS.

These resources are intended for skilled developers designing with TI products. You are solely responsible for (1) selecting the appropriate TI products for your application, (2) designing, validating and testing your application, and (3) ensuring your application meets applicable standards, and any other safety, security, regulatory or other requirements.

These resources are subject to change without notice. TI grants you permission to use these resources only for development of an application that uses the TI products described in the resource. Other reproduction and display of these resources is prohibited. No license is granted to any other TI intellectual property right or to any third party intellectual property right. TI disclaims responsibility for, and you will fully indemnify TI and its representatives against, any claims, damages, costs, losses, and liabilities arising out of your use of these resources.

TI's products are provided subject to [TI's Terms of Sale](#) or other applicable terms available either on ti.com or provided in conjunction with such TI products. TI's provision of these resources does not expand or otherwise alter TI's applicable warranties or warranty disclaimers for TI products.

TI objects to and rejects any additional or different terms you may have proposed.

Mailing Address: Texas Instruments, Post Office Box 655303, Dallas, Texas 75265
Copyright © 2022, Texas Instruments Incorporated