



**Table of Contents**

1 Overview.....2

2 Functional Safety Failure In Time (FIT) Rates.....3

3 Failure Mode Distribution (FMD).....4

4 Pin Failure Mode Analysis (Pin FMA).....5

**Trademarks**

All trademarks are the property of their respective owners.

## 1 Overview

This document contains information for the DRV8910-Q1 (HTSSOP package) to aid in a functional safety system design. Information provided are:

- Functional safety failure in time (FIT) rates of the semiconductor component estimated by the application of industry reliability standards
- Component failure modes and their distribution (FMD) based on the primary function of the device
- Pin failure mode analysis (pin FMA)

Figure 1-1 shows the device functional block diagram for reference.

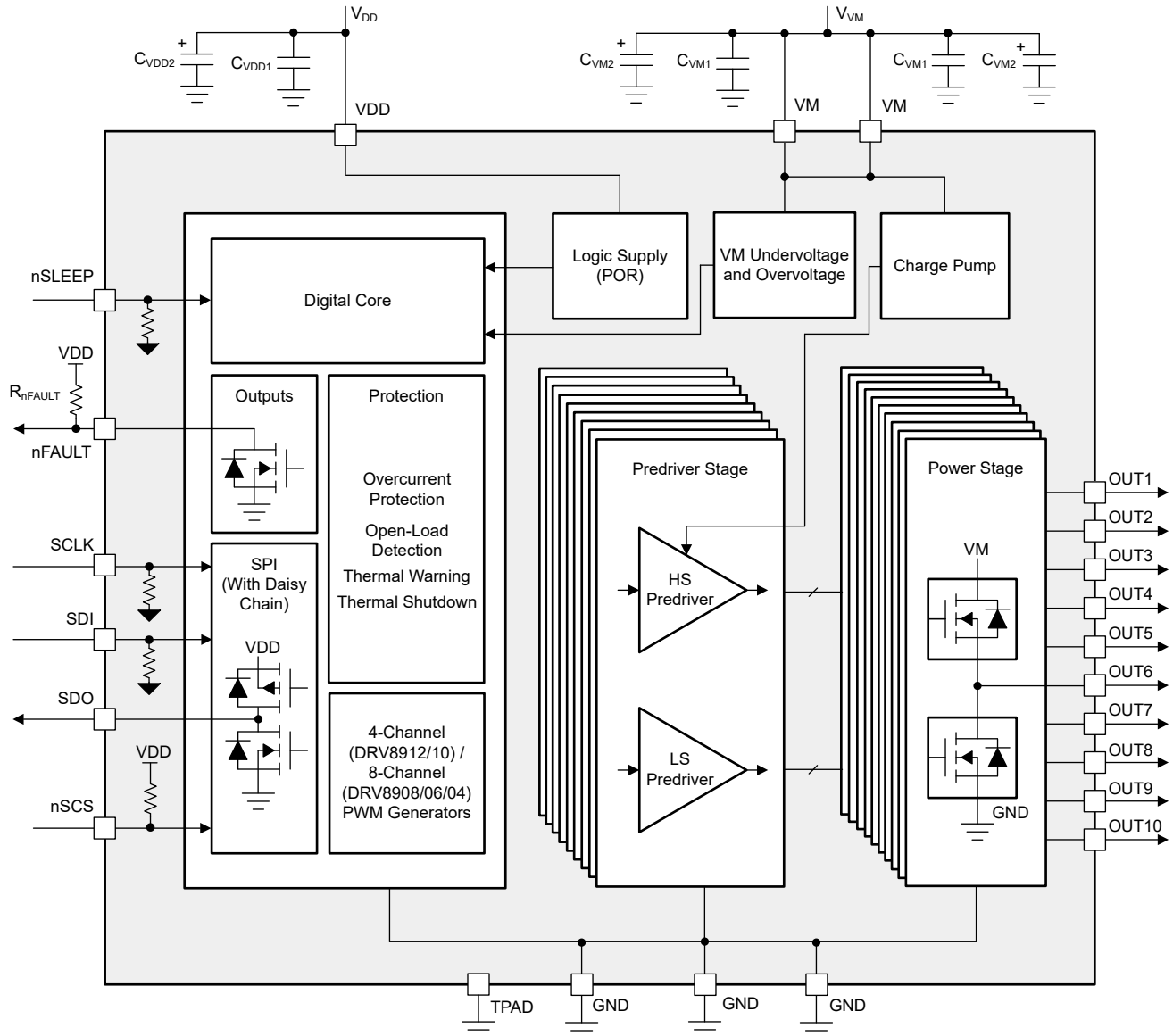

**Figure 1-1. Functional Block Diagram**

The DRV8910-Q1 was developed using a quality-managed development process, but was not developed in accordance with the IEC 61508 or ISO 26262 standards.

## 2 Functional Safety Failure In Time (FIT) Rates

This section provides functional safety failure in time (FIT) rates for the DRV8910-Q1 based on two different industry-wide used reliability standards:

- [Table 2-1](#) provides FIT rates based on IEC TR 62380 / ISO 26262 part 11
- [Table 2-2](#) provides FIT rates based on the Siemens Norm SN 29500-2

**Table 2-1. Component Failure Rates per IEC TR 62380 / ISO 26262 Part 11**

FIT IEC TR 62380 / ISO 26262	FIT (Failures Per 10 <sup>9</sup> Hours)
Total component FIT rate	23
Die FIT rate	7
Package FIT rate	16

The failure rate and mission profile information in [Table 2-1](#) comes from the reliability data handbook IEC TR 62380 / ISO 26262 part 11:

- Mission profile: motor control from table 11
- Power dissipation: 1150 mW
- Climate type: world-wide table 8
- Package factor (lambda 3): table 17b
- Substrate material: FR4
- EOS FIT rate assumed: 0 FIT

**Table 2-2. Component Failure Rates per Siemens Norm SN 29500-2**

Table	Category	Reference FIT Rate	Reference Virtual T <sub>J</sub>
5	CMOS, BICMOS Digital, analog, or mixed	25 FIT	55°C

The reference FIT rate and reference virtual T<sub>J</sub> (junction temperature) in [Table 2-2](#) come from the Siemens Norm SN 29500-2 tables 1 through 5. Failure rates under operating conditions are calculated from the reference failure rate and virtual junction temperature using conversion information in SN 29500-2 section 4.

### 3 Failure Mode Distribution (FMD)

The failure mode distribution estimation for the DRV8910-Q1 in [Table 3-1](#) comes from the combination of common failure modes listed in standards such as IEC 61508 and ISO 26262, the ratio of sub-circuit function size and complexity, and from best engineering judgment.

The failure modes listed in this section reflect random failure events and do not include failures resulting from misuse or overstress.

**Table 3-1. Die Failure Modes and Distribution**

Die Failure Modes	Failure Mode Distribution (%)
Output is stuck LOW when commanded OFF (GND short)	11% <sup>(1)</sup>
Output is stuck HIGH when commanded OFF (VM short)	11% <sup>(1)</sup>
Output is stuck OFF when commanded LOW (Open)	14% <sup>(1)</sup>
Output is stuck OFF when commanded HIGH (Open)	14% <sup>(1)</sup>
Output ON resistance too high when commanded LOW	11% <sup>(1)</sup>
Output ON resistance too high when commanded HIGH	11% <sup>(1)</sup>
Low side slew rate too fast or too slow (high-side recirculation)	5% <sup>(1)</sup>
High side slew rate too fast or too slow (low-side recirculation)	5% <sup>(1)</sup>
Dead-time is too short	4% <sup>(1)</sup>
Incorrect SPI communication	12%
Incorrect input interpretation (nSLEEP)	1%
Incorrect nFAULT assertion	1%

(1) Divide this number by 12 for FMD of each individual OUTx pin. This device leaves 2 channels unconnected internally.

DRV8910-Q1 was developed using a quality-managed development process, but was not developed in accordance with the IEC 61508 or ISO 26262 standards.

## 4 Pin Failure Mode Analysis (Pin FMA)

This section provides a failure mode analysis (FMA) for the pins of the DRV8910-Q1. The failure modes covered in this document include the typical pin-by-pin failure scenarios:

- Pin short-circuited to ground (see [Table 4-2](#))
- Pin open-circuited (see [Table 4-3](#))
- Pin short-circuited to an adjacent pin (see [Table 4-4](#))
- Pin short-circuited to VM (see [Table 4-5](#))

[Table 4-2](#) through [Table 4-5](#) also indicate how these pin conditions can affect the device as per the failure effects classification in [Table 4-1](#).

**Table 4-1. TI Classification of Failure Effects**

Class	Failure Effects
A	Potential device damage that affects functionality.
B	No device damage, but loss of functionality.
C	No device damage, but performance degradation.
D	No device damage, no impact to functionality or performance.

[Figure 4-1](#) shows the DRV8910-Q1 pin diagram. For a detailed description of the device pins, see the *Pin Configuration and Functions* section in the DRV8910-Q1 data sheet.

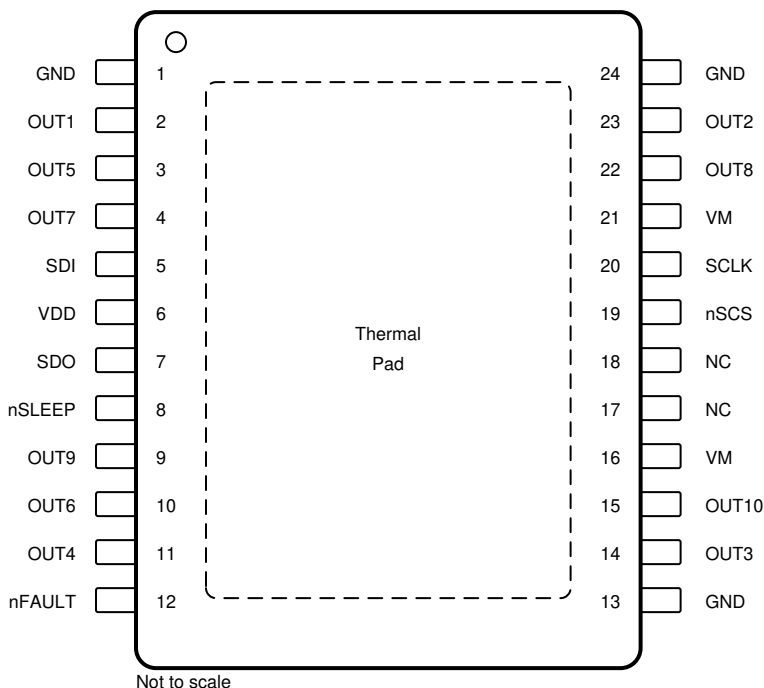

**Figure 4-1. Pin Diagram**

Following are the assumptions of use and the device configuration assumed for the pin FMA in this section:

- The device is used with external components consistent with the values described in the external component table of the datasheet.

**Table 4-2. Pin FMA for Device Pins Short-Circuited to Ground**

Pin Name	Pin No.	Description of Potential Failure Effect(s)	Failure Effect Class
GND	1, 13, 24	Normal function.	D
OUT1	2	If OUT1 is commanded to be pulled high, short is detected and outputs are Hi-Z.	B

**Table 4-2. Pin FMA for Device Pins Short-Circuited to Ground (continued)**

Pin Name	Pin No.	Description of Potential Failure Effect(s)	Failure Effect Class
OUT5	3	If OUT5 is commanded to be pulled high, short is detected and outputs are Hi-Z.	B
OUT7	4	If OUT7 is commanded to be pulled high, short is detected and outputs are Hi-Z.	B
SDI	5	SPI communication is lost.	B
VDD	6	Device will be in SLEEP state and outputs are Hi-Z.	B
SDO	7	SPI communication is lost.	B
nSLEEP	8	Device will be in SLEEP state and outputs are Hi-Z.	B
OUT9	9	If OUT9 is commanded to be pulled high, short is detected and outputs are Hi-Z.	B
OUT6	10	If OUT6 is commanded to be pulled high, short is detected and outputs are Hi-Z.	B
OUT4	11	If OUT4 is commanded to be pulled high, short is detected and outputs are Hi-Z.	B
nFAULT	12	False fault signalling possible. Device will continue to operate as commanded.	B
OUT3	14	If OUT3 is commanded to be pulled high, short is detected and outputs are Hi-Z.	B
OUT10	15	If OUT10 is commanded to be pulled high, short is detected and outputs are Hi-Z.	B
VM	16, 21	Device is powered off with driver Hi-Z.	B
NC	17, 18	Unused pin	D
nSCS	19	SPI communication is lost.	B
SCLK	20	SPI communication is lost.	B
OUT8	22	If OUT8 is commanded to be pulled high, short is detected and outputs are Hi-Z.	B
OUT2	23	If OUT2 is commanded to be pulled high, short is detected and outputs are Hi-Z.	B

**Table 4-3. Pin FMA for Device Pins Open-Circuited**

Pin Name	Pin No.	Description of Potential Failure Effect(s)	Failure Effect Class
GND	1, 13, 24	Device is powered off with driver Hi-Z.	B
OUT1	2	Load drive capability is lost.	B
OUT5	3	Load drive capability is lost.	B
OUT7	4	Load drive capability is lost.	B
SDI	5	SPI communication is lost.	B
VDD	6	Device will be in SLEEP state and outputs are Hi-Z.	B
SDO	7	SPI communication is lost.	B
nSLEEP	8	Device will be in SLEEP state and outputs are Hi-Z.	B
OUT9	9	Load drive capability is lost.	B
OUT6	10	Load drive capability is lost.	B
OUT4	11	Load drive capability is lost.	B
nFAULT	12	False fault signaling possible. Device will continue to operate as commanded.	B
OUT3	14	Load drive capability is lost.	B
OUT10	15	Load drive capability is lost.	B
VM	16, 21	Device is powered off with driver Hi-Z.	B
NC	17, 18	Unused pin	D
nSCS	19	SPI communication is lost.	B
SCLK	20	SPI communication is lost.	B
OUT8	22	Load drive capability is lost.	B
OUT2	23	Load drive capability is lost.	B

**Table 4-4. Pin FMA for Device Pins Short-Circuited to Adjacent Pin**

Pin Name	Pin No.	Shorted to	Description of Potential Failure Effect(s)	Failure Effect Class
GND	1	GND	Normal function.	D
OUT1	2	GND	If OUT1 is commanded to be pulled high, short is detected and OUT1 is Hi-Z.	B
OUT5	3	OUT1	Load drive capability is lost.	B
OUT7	4	OUT5	Load drive capability is lost.	B
SDI	5	OUT7	SPI communication is lost. Low voltage pin max voltage may be violated.	A
VDD	6	SDI	SPI communication is lost.	B
SDO	7	VDD	SPI communication is lost.	B
nSLEEP	8	SDO	SPI communication is lost.	B
OUT9	9	nSLEEP	Low voltage pin max voltage may be violated.	A
OUT6	10	OUT9	Load drive capability is lost.	B
OUT4	11	OUT6	Load drive capability is lost.	B
nFAULT	12	OUT4	False fault signalling possible. Low voltage pin max voltage may be violated.	A
GND	13	nFAULT	False fault signalling possible. Device will continue to operate as commanded.	B
OUT3	14	GND	If OUT3 is commanded to be pulled high, short is detected and OUT3 is Hi-Z.	B
OUT10	15	OUT3	Load drive capability is lost.	B
VM	16	OUT10	If OUT10 is commanded to be pulled low, short is detected and OUT10 is Hi-Z.	B
NC	17	VM	Short to unused pin.	D
NC	18	NC	Short to unused pin.	D
nSCS	19	NC	Short to unused pin.	D
SCLK	20	nSCS	SPI communication is lost.	B
VM	21	SCLK	SPI communication is lost. Low voltage pin max voltage may be violated.	A
OUT8	22	VM	If OUT8 is commanded to be pulled low, short is detected and OUT8 is Hi-Z.	B
OUT2	23	OUT8	Load drive capability is lost.	B
GND	24	OUT2	If OUT2 is commanded to be pulled high, short is detected and OUT2 is Hi-Z.	B

**Table 4-5. Pin FMA for Device Pins Short-Circuited to VM**

Pin Name	Pin No.	Description of Potential Failure Effect(s)	Failure Effect Class
GND	1, 13, 24	Device is powered off with driver Hi-Z.	B
OUT1	2	If OUT1 is commanded to be pulled low, short is detected and outputs are Hi-Z.	B
OUT5	3	If OUT5 is commanded to be pulled low, short is detected and outputs are Hi-Z.	B
OUT7	4	If OUT7 is commanded to be pulled low, short is detected and outputs are Hi-Z.	B
SDI	5	SPI communication is lost. Low voltage pin max voltage may be violated.	A
VDD	6	Low voltage pin max voltage may be violated.	A
SDO	7	SPI communication is lost. Low voltage pin max voltage may be violated.	A
nSLEEP	8	Low voltage pin max voltage may be violated.	A
OUT9	9	If OUT9 is commanded to be pulled low, short is detected and outputs are Hi-Z.	B
OUT6	10	If OUT6 is commanded to be pulled low, short is detected and outputs are Hi-Z.	B
OUT4	11	If OUT4 is commanded to be pulled low, short is detected and outputs are Hi-Z.	B
nFAULT	12	Low voltage pin max voltage may be violated.	A
OUT3	14	If OUT3 is commanded to be pulled low, short is detected and outputs are Hi-Z.	B
OUT10	15	If OUT10 is commanded to be pulled low, short is detected and outputs are Hi-Z.	B
VM	16, 21	Normal function.	D
NC	17, 18	Short to unused pin.	D
nSCS	19	SPI communication is lost. Low voltage pin max voltage may be violated.	A

**Table 4-5. Pin FMA for Device Pins Short-Circuited to VM (continued)**

<b>Pin Name</b>	<b>Pin No.</b>	<b>Description of Potential Failure Effect(s)</b>	<b>Failure Effect Class</b>
SCLK	20	SPI communication is lost. Low voltage pin max voltage may be violated.	A
OUT8	22	If OUT8 is commanded to be pulled low, short is detected and outputs are Hi-Z.	B
OUT2	23	If OUT2 is commanded to be pulled low, short is detected and outputs are Hi-Z.	B



## IMPORTANT NOTICE AND DISCLAIMER

TI PROVIDES TECHNICAL AND RELIABILITY DATA (INCLUDING DATA SHEETS), DESIGN RESOURCES (INCLUDING REFERENCE DESIGNS), APPLICATION OR OTHER DESIGN ADVICE, WEB TOOLS, SAFETY INFORMATION, AND OTHER RESOURCES "AS IS" AND WITH ALL FAULTS, AND DISCLAIMS ALL WARRANTIES, EXPRESS AND IMPLIED, INCLUDING WITHOUT LIMITATION ANY IMPLIED WARRANTIES OF MERCHANTABILITY, FITNESS FOR A PARTICULAR PURPOSE OR NON-INFRINGEMENT OF THIRD PARTY INTELLECTUAL PROPERTY RIGHTS.

These resources are intended for skilled developers designing with TI products. You are solely responsible for (1) selecting the appropriate TI products for your application, (2) designing, validating and testing your application, and (3) ensuring your application meets applicable standards, and any other safety, security, regulatory or other requirements.

These resources are subject to change without notice. TI grants you permission to use these resources only for development of an application that uses the TI products described in the resource. Other reproduction and display of these resources is prohibited. No license is granted to any other TI intellectual property right or to any third party intellectual property right. TI disclaims responsibility for, and you will fully indemnify TI and its representatives against, any claims, damages, costs, losses, and liabilities arising out of your use of these resources.

TI's products are provided subject to [TI's Terms of Sale](#) or other applicable terms available either on [ti.com](http://ti.com) or provided in conjunction with such TI products. TI's provision of these resources does not expand or otherwise alter TI's applicable warranties or warranty disclaimers for TI products.

TI objects to and rejects any additional or different terms you may have proposed.

Mailing Address: Texas Instruments, Post Office Box 655303, Dallas, Texas 75265  
Copyright © 2022, Texas Instruments Incorporated