

# TPSM365R1x Functional Safety FIT Rate, FMD and Pin FMA



## Table of Contents

<b>1 Overview</b> .....	<b>2</b>
<b>2 Functional Safety Failure In Time (FIT) Rates</b> .....	<b>3</b>
2.1 TPSM365R15.....	3
2.2 TPSM365R1.....	4
<b>3 Failure Mode Distribution (FMD)</b> .....	<b>5</b>
<b>4 Pin Failure Mode Analysis (Pin FMA)</b> .....	<b>6</b>

### Trademarks

All trademarks are the property of their respective owners.

# 1 Overview

This document contains information for TPSM365R1x (QFN-HR package) to aid in a functional safety system design. Information provided are:

- Functional Safety Failure In Time (FIT) rates of the semiconductor component estimated by the application of industry reliability standards
- Component failure modes and their distribution (FMD) based on the primary function of the device
- Pin failure mode analysis (Pin FMA)

Figure 1-1 shows the device functional block diagram for reference.

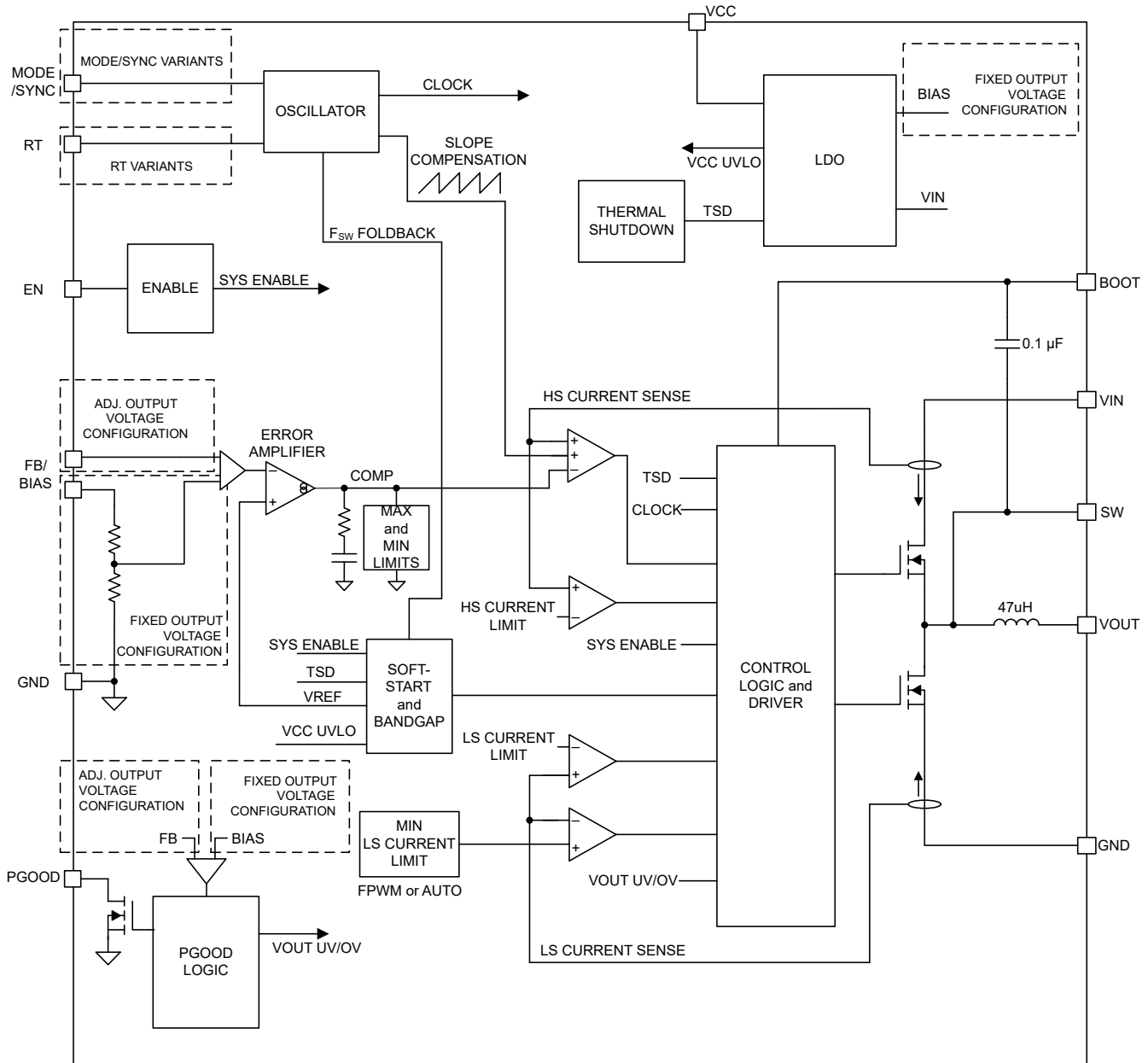

**Figure 1-1. Functional Block Diagram**

TPSM365R1x was developed using a quality-managed development process, but was not developed in accordance with the IEC 61508 or ISO 26262 standards.

## 2 Functional Safety Failure In Time (FIT) Rates

### 2.1 TP3M365R15

This section provides Functional Safety Failure In Time (FIT) rates for TP3M365R1x based on two different industry-wide used reliability standards:

- [Table 2-1](#) provides FIT rates based on IEC TR 62380 / ISO 26262 part 11
- [Table 2-2](#) provides FIT rates based on the Siemens Norm SN 29500-2

**Table 2-1. Component Failure Rates per IEC TR 62380 / ISO 26262 Part 11**

FIT IEC TR 62380 / ISO 26262	FIT (Failures Per 10 <sup>9</sup> Hours)
Total Component FIT Rate	27
Die FIT Rate	4
Package FIT Rate	23

The failure rate and mission profile information in [Table 2-1](#) comes from the Reliability data handbook IEC TR 62380 / ISO 26262 part 11:

- Mission Profile: Motor Control from Table 11
- Power dissipation: 195 mW
- Climate type: World-wide Table 8
- Package factor (lambda 3): Table 17b
- Substrate Material: FR4
- EOS FIT rate assumed: 0 FIT

**Table 2-2. Component Failure Rates per Siemens Norm SN 29500-2**

Table	Category	Reference FIT Rate	Reference Virtual T <sub>J</sub>
5	CMOS/ BICMOS ASICs Analog & Mixed HV > 50-V supply	30 FIT	75°C

The Reference FIT Rate and Reference Virtual T<sub>J</sub> (junction temperature) in [Table 2-2](#) come from the Siemens Norm SN 29500-2 tables 1 through 5. Failure rates under operating conditions are calculated from the reference failure rate and virtual junction temperature using conversion information in SN 29500-2 section 4.

## 2.2 TPSM365R1

This section provides Functional Safety Failure In Time (FIT) rates for TPSM365R1x based on two different industry-wide used reliability standards:

- [Table 2-3](#) provides FIT rates based on IEC TR 62380 / ISO 26262 part 11
- [Table 2-4](#) provides FIT rates based on the Siemens Norm SN 29500-2

**Table 2-3. Component Failure Rates per IEC TR 62380 / ISO 26262 Part 11**

FIT IEC TR 62380 / ISO 26262	FIT (Failures Per 10 <sup>9</sup> Hours)
Total Component FIT Rate	25
Die FIT Rate	3
Package FIT Rate	22

The failure rate and mission profile information in [Table 2-3](#) comes from the Reliability data handbook IEC TR 62380 / ISO 26262 part 11:

- Mission Profile: Motor Control from Table 11
- Power dissipation: 140 mW
- Climate type: World-wide Table 8
- Package factor (lambda 3): Table 17b
- Substrate Material: FR4
- EOS FIT rate assumed: 0 FIT

**Table 2-4. Component Failure Rates per Siemens Norm SN 29500-2**

Table	Category	Reference FIT Rate	Reference Virtual T <sub>J</sub>
5	CMOS/ BICMOS ASICs Analog & Mixed HV > 50-V supply	30 FIT	75°C

The Reference FIT Rate and Reference Virtual T<sub>J</sub> (junction temperature) in [Table 2-4](#) come from the Siemens Norm SN 29500-2 tables 1 through 5. Failure rates under operating conditions are calculated from the reference failure rate and virtual junction temperature using conversion information in SN 29500-2 section 4.

### 3 Failure Mode Distribution (FMD)

The failure mode distribution estimation for TPSM365R1x in [Table 3-1](#) comes from the combination of common failure modes listed in standards such as IEC 61508 and ISO 26262, the ratio of sub-circuit function size and complexity and from best engineering judgment.

The failure modes listed in this section reflect random failure events and do not include failures due to misuse or overstress.

**Table 3-1. Die Failure Modes and Distribution**

Die Failure Modes	Failure Mode Distribution (%)
No Output Voltage	60%
Output not in specification - voltage or timing	30%
Power Good - False Trip or Failure to Trip	5%
Short Circuit any two pins	5%

## 4 Pin Failure Mode Analysis (Pin FMA)

This section provides a Failure Mode Analysis (FMA) for the pins of the TPSM365R1x. The failure modes covered in this document include the typical pin-by-pin failure scenarios:

- Pin short-circuited to Ground (see [Table 4-2](#))
- Pin open-circuited (see [Table 4-3](#))
- Pin short-circuited to an adjacent pin (see [Table 4-4](#))
- Pin short-circuited to supply (see [Table 4-5](#))

[Table 4-2](#) through [Table 4-5](#) also indicate how these pin conditions can affect the device as per the failure effects classification in [Table 4-1](#).

**Table 4-1. TI Classification of Failure Effects**

Class	Failure Effects
A	Potential device damage that affects functionality
B	No device damage, but loss of functionality
C	No device damage, but performance degradation
D	No device damage, no impact to functionality or performance

[Figure 4-1](#) shows the TPSM365R1x pin diagram. For a detailed description of the device pins please refer to the *Pin Configuration and Functions* section in the TPSM365R1x data sheet.

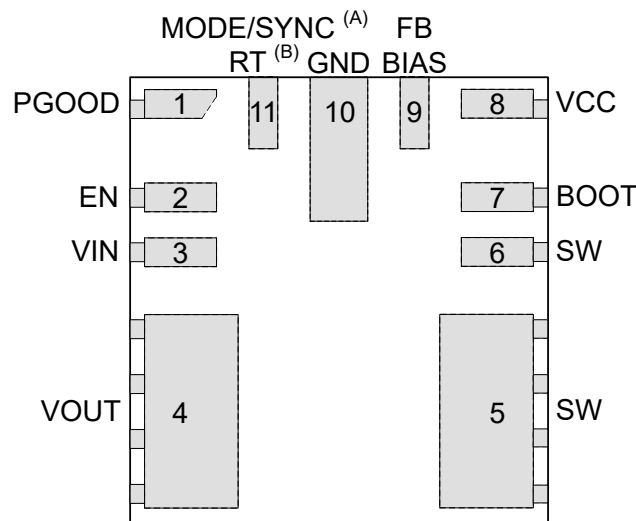

1. See the *data sheet* for more details. Pin 1 trimmed and factory-set for externally adjustable switching frequency RT variants only.
2. Pin 11 factory-set for fixed switching frequency MODE/SYNC variants only.
3. Pin 9 trimmed and factory-set for fixed output voltage VOUT/BIAS variants only.
4. Pin 9 factory-set for adjustable output voltage FB variants only.

**Figure 4-1. Pin Diagram**

**Table 4-2. Pin FMA for Device Pins Short-Circuited to Ground**

Pin Name	Pin No.	Description of Potential Failure Effect(s)	Failure Effect Class
PGOOD	1	When not in use, this pin can be left open or grounded. However, PGOOD is no longer reliably relays Power-Good information to devices connected to this pin.	B
EN	2	VOUT = 0 V, device is disabled.	B
VIN	3	VOUT = 0 V.	B
VOUT	4	Goes into hiccup, short-circuit operation.	B
SW	5, 6	Damage occurs.	A
BOOT	7	VOUT = 0 V, HS FET does not turn on.	B
VCC	8	VOUT = 0 V.	B
VOUT/BIAS or FB	9	VOUT = 0 V.	B
GND	10	Normal operation.	D
RT or MODE	11	For RT, the switching frequency is set to 2.2 MHz. For MODE/SYNC the device goes into PFM mode.	B

**Table 4-3. Pin FMA for Device Pins Open-Circuited**

Pin Name	Pin No.	Description of Potential Failure Effect(s)	Failure Effect Class
PGOOD	1	When not in use, this pin can be left open or grounded. However, PGOOD is no longer reliably relays Power-Good information to devices connected to this pin.	B
EN	2	VOUT behavior is not defined. VOUT may be 0V, but it also may be up. Do not float this pin. Device can no longer reliably be enabled or disabled by other devices connected to this pin.	B
VIN	3	VOUT = 0 V.	B
VOUT	4	VOUT = 0 V.	B
SW	5, 6	Normal operation.	D
BOOT	7	Normal operation.	D
VCC	8	VCC output is unstable, can increase above 5.5 V	A
FB	9	VOUT = 0 V. Do not float this pin.	B
GND	10	VOUT can be abnormal, as reference voltage is not fixed.	B
RT or MODE	11	If it is RT device, then frequency is not defined. If it is a MODE/SYNC device, then the device can go back and forth between FPWM and PFM. VOUT is up, but only partially functional.	C

**Table 4-4. Pin FMA for Device Pins Short-Circuited to Adjacent Pin**

Pin Name	Pin No.	Shorted to	Description of Potential Failure Effect(s)	Failure Effect Class
PGOOD	1	EN	If EN > 20 V, it damages devices connected to the PGOOD pin.	A
EN	2	VIN	VOUT normal (enable is on, all other blocks work). However, the device can no longer be disabled.	B
VIN	3	VOUT	If VIN > 16 V, damage occurs.	A
VOUT	4	SW	Damage occurs.	A
SW	6	BOOT	VOUT = 0 V, HS does not turn on, no Cboot.	B
BOOT	7	VCC	Damage occurs to VCC LDO. The VCC LDO could no longer supply voltage to internal control circuits.	A
VCC	8	FB	Can be partially nonfunctional, no damage occurs.	B
FB	9	GND	VOUT = 0 V (for fixed option) switches at maximum duty cycle for ADJ option.	B

**Table 4-4. Pin FMA for Device Pins Short-Circuited to Adjacent Pin (continued)**

Pin Name	Pin No.	Shorted to	Description of Potential Failure Effect(s)	Failure Effect Class
GND	10	RT or MODE	For RT, Switching Frequency is set to 2.2 MHz. For MODE/SYNC the device goes into PFM mode.	B
RT or MODE	11	PGOOD	If PGOOD is high and < 5.5 V, then Fsw = 1 MHz for RT, and is in FPWM mode for MODE/SYNC; If PGOOD is low, then Fsw = 2.2 MHz for RT, and PFM mode for RT. PGOOD absmax being 20 V, RT ESD damages if PG goes to 20 V.	A

**Table 4-5. Pin FMA for Device Pins Short-Circuited to supply**

Pin Name	Pin No.	Description of Potential Failure Effect(s)	Failure Effect Class
PGOOD	1	If VIN > 20 V, it damages PGOOD. PGOOD is no longer reliably relays Power-Good information to devices connected to this pin.	A
EN	2	VOUT normal (enable is on, all other blocks work). However, the device can no longer be disabled.	B
VIN	3	Normal operation.	D
VOUT	4	Damage occurs, if VIN > 16 V.	A
SW	5, 6	Damage occurs.	A
BOOT	7	Damage occurs, the BOOT ESD clamp is damaged.	A
VCC	8	If Vin > 5.5 V, damage occurs.	A
FB	9	If VIN > 20 V, damage occurs.	A
GND	10	VOUT = 0 V.	A
RT	11	If Vin > 5.5 V, damage occurs. If Vin < 5.5 V, switching frequency is 1 MHz.	A



## IMPORTANT NOTICE AND DISCLAIMER

TI PROVIDES TECHNICAL AND RELIABILITY DATA (INCLUDING DATA SHEETS), DESIGN RESOURCES (INCLUDING REFERENCE DESIGNS), APPLICATION OR OTHER DESIGN ADVICE, WEB TOOLS, SAFETY INFORMATION, AND OTHER RESOURCES "AS IS" AND WITH ALL FAULTS, AND DISCLAIMS ALL WARRANTIES, EXPRESS AND IMPLIED, INCLUDING WITHOUT LIMITATION ANY IMPLIED WARRANTIES OF MERCHANTABILITY, FITNESS FOR A PARTICULAR PURPOSE OR NON-INFRINGEMENT OF THIRD PARTY INTELLECTUAL PROPERTY RIGHTS.

These resources are intended for skilled developers designing with TI products. You are solely responsible for (1) selecting the appropriate TI products for your application, (2) designing, validating and testing your application, and (3) ensuring your application meets applicable standards, and any other safety, security, regulatory or other requirements.

These resources are subject to change without notice. TI grants you permission to use these resources only for development of an application that uses the TI products described in the resource. Other reproduction and display of these resources is prohibited. No license is granted to any other TI intellectual property right or to any third party intellectual property right. TI disclaims responsibility for, and you will fully indemnify TI and its representatives against, any claims, damages, costs, losses, and liabilities arising out of your use of these resources.

TI's products are provided subject to [TI's Terms of Sale](#) or other applicable terms available either on [ti.com](https://www.ti.com) or provided in conjunction with such TI products. TI's provision of these resources does not expand or otherwise alter TI's applicable warranties or warranty disclaimers for TI products.

TI objects to and rejects any additional or different terms you may have proposed.

Mailing Address: Texas Instruments, Post Office Box 655303, Dallas, Texas 75265  
Copyright © 2023, Texas Instruments Incorporated