

Adding shutdown feature to MC33063A, MC34063A switching regulators

Ronald Michallick

Standard Linear and Logic

ABSTRACT

The MC33063A and MC34063A switching regulators are inexpensive and easy to use. However, the devices do not have a shutdown pin to disable the output power. This application report demonstrates methods to incorporate an output shutdown feature using external components to disable the power switch.

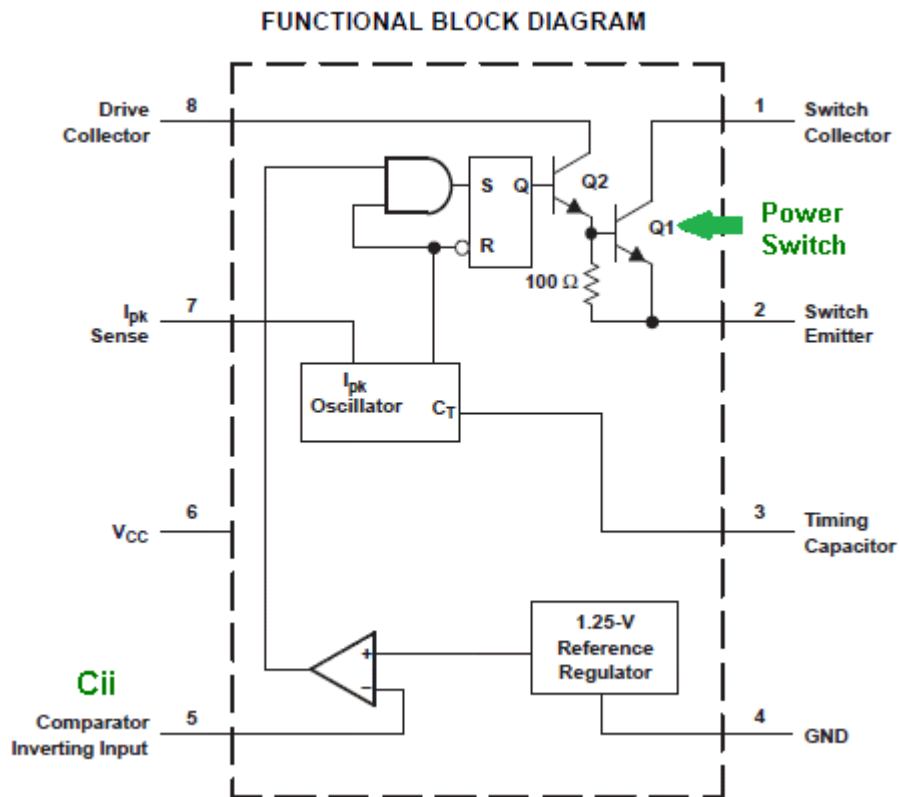

Figure 1

Shutdown implementation

In this application note, all references to the MC34063A also apply to the extended temperature range MC33063A. These regulators are economical and easy to use, but do not have a shutdown feature to turn the output off. This application note demonstrates three methods to implement a shutdown feature with the MC34063A.

The MC34063A (figure 1) supplies fixed on time drive to the internal power switch when the “Comparator inverting input” (abbreviated as “Cii”) is less than the internal 1.25V reference voltage. When the Cii is greater than the internal reference, the output switch will remain off. Therefore, keeping the Cii pin above 1.25V will stop the output switch (the oscillator will continue to run) and the output will decay to zero volts when used as a buck or inverting regulator. However, the boost setup will have an output voltage that will be one diode drop less than input voltage. Even with the switch disabled the catch diode conducts from VIN to VOUT.

The recommended range for the Cii input is -0.3V to 40V relative to the ground pin. A diode, PMOS transistor or PNP transistor can be used to pull the Cii pin to any level greater than 1.3V (relative to GND pin) to stop the MC34063A switch, but the added circuitry must not affect the feedback network when the MC34063A is enabled.

For boost operation, a load switch should be added in series with the input power source. A load switch can also be used for the buck and inverting operation.

Table 1 shows which shutdown method can be used with various MC33063 topologies.

Table 1. Shutdown method and topology compatibility Table

Shutdown Method	Buck	Inverting	Boost
Load Switch to VCC	Yes	Yes	Yes
PNP/PMOS to Cii	Yes	Yes	No
Diode to Cii	Yes	No	No

Buck regulator shutdown circuit example (using diode to Cii)

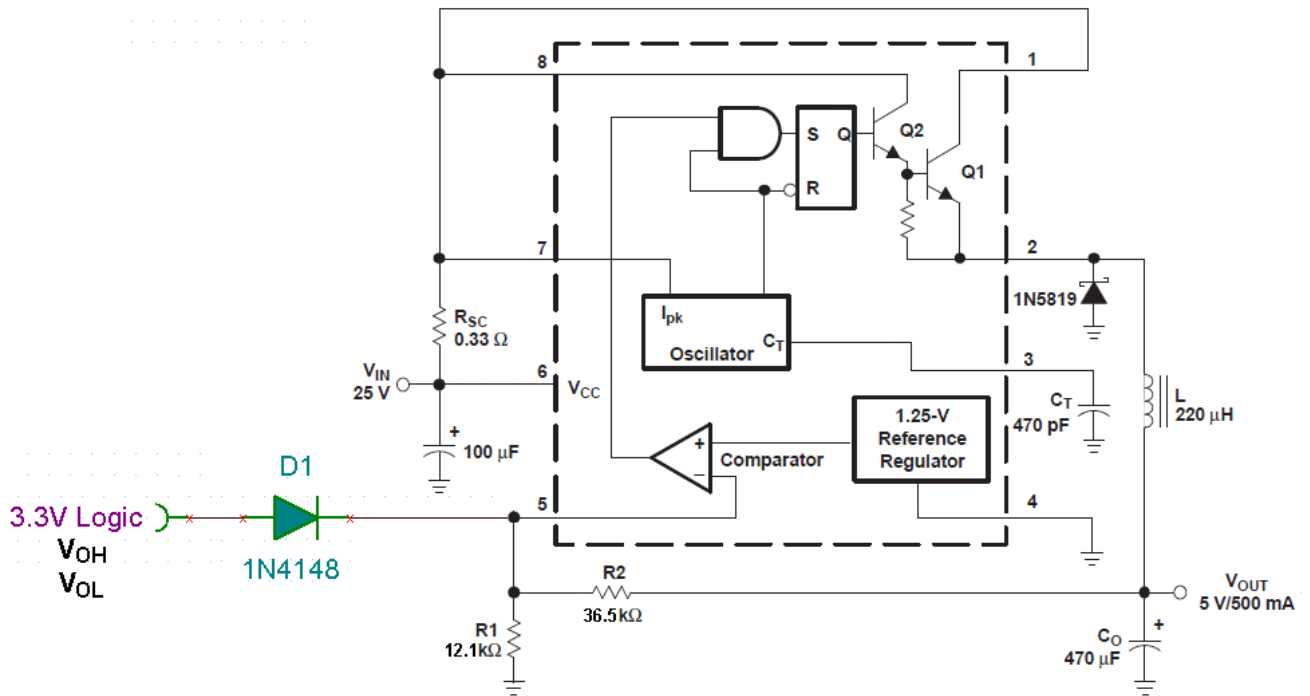

Only one component (D1) is needed to disable the MC34063A and shut down the 5V output when controlled by 3.3V logic. When the logic input is low, D1 is reversed biased and has no effect on the output voltage ($V_{OL} + V_F < 1.25V$). When the logic input is high, D1 is forward biased and will pull Cii, pin 5, up to $(V_{OH} - V_F)$. V_F is the D1 diode's forward voltage. With the power switch forced off, V_{OUT} will drop to near zero and the input current will be the MC34063A bias current typically 2.5mA. R2 will pass a small current, $(V_{OH}-V_F)/R_2$, to the output node. The current required from the logic input is

$$(V_{OH}-V_F) \times \left(\frac{1}{R_1} + \frac{1}{R_2} \right) = (3.3V - 0.7V) \times \left(\frac{1}{12.1k\Omega} + \frac{1}{36.5k\Omega} \right) = 286\mu A$$

If the logic input source was powered by 1.8V then the V_{OH} voltage on the cathode of D1 would not be high enough to reliably pull Cii above 1.3V. For 1.8V logic, the PNP example in the inverting regulator shutdown circuit example should be used instead.

Inverting regulator shutdown circuit example (using PNP to Cii)

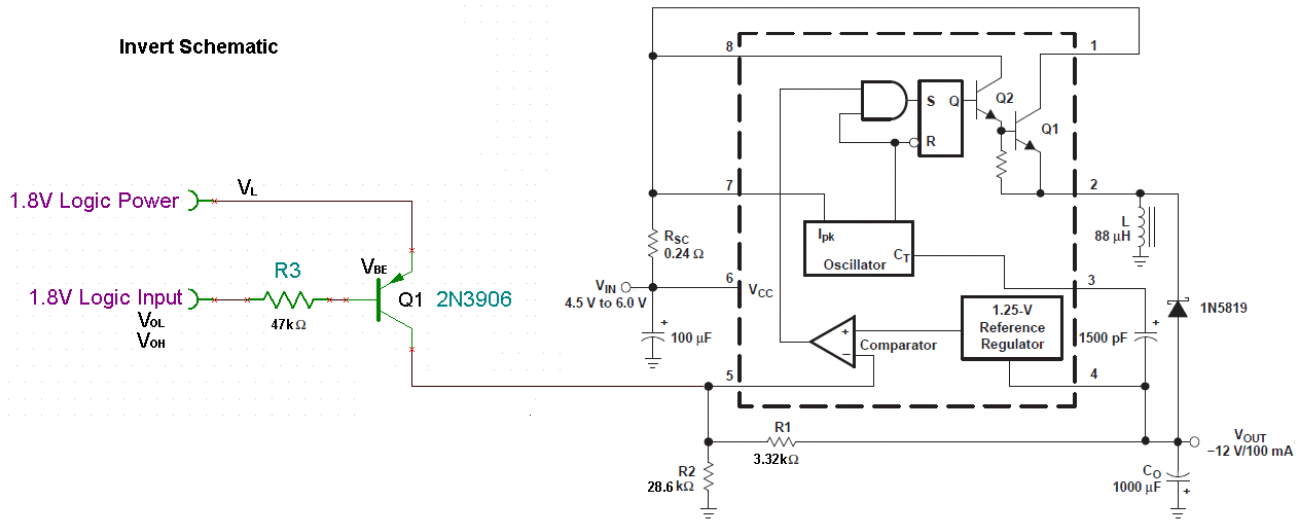

For the inverting regulator, two components (R3&Q1) are needed to disable the MC34063A and shut down the -12V output. When the logic input is high, Q1 is cut off and no collector current will flow. Therefore, Q1 has no effect on the output voltage. When the logic input is low, current will flow through the Q1 base emitter junction. With sufficient base current, Q1 will pull pin 5 (Cii) voltage close to the logic supply voltage.

With the power switch forced off, V_{OUT} will drop to near zero and the input current will be the MC34063A bias current typically 2.5mA. However, the MC34063A bias current (pin 4) and R1 current will flow through the Schottky diode and inductor to ground if the output load is light. In this case a small positive voltage, about +0.25V will be present on the output capacitor (and the load) during shutdown. Contact the capacitor's manufacturer to verify that this will be safely tolerated.

The current required from the low logic input is
$$\frac{V_L - V_{BE} - V_{OL}}{R_3} = \frac{1.8V - 0.7V - 0.0V}{47k\Omega} = 23\mu A$$

Q1's collector current will be about
$$V_L \times \left(\frac{1}{R_1} + \frac{1}{R_2} \right) = 1.8V \times \left(\frac{1}{3.32k\Omega} + \frac{1}{28.6k\Omega} \right) = 0.6mA$$

The PNP transistor can be replaced with a PMOS transistor if preferred. The PMOS threshold voltage should be chosen to keep the transistor off with V_{OH} input and pass required current with V_{OL} input. R3 can remain to limit peak capacitive gate current.

The output enabled Cii voltage (relative to system ground) is $V_{OUT} + 1.25V = -10.75V$; therefore the single diode circuit used in the buck application example can not be used because the diode would be always forward biased.

Boost regulator shutdown circuit example (using load switch)

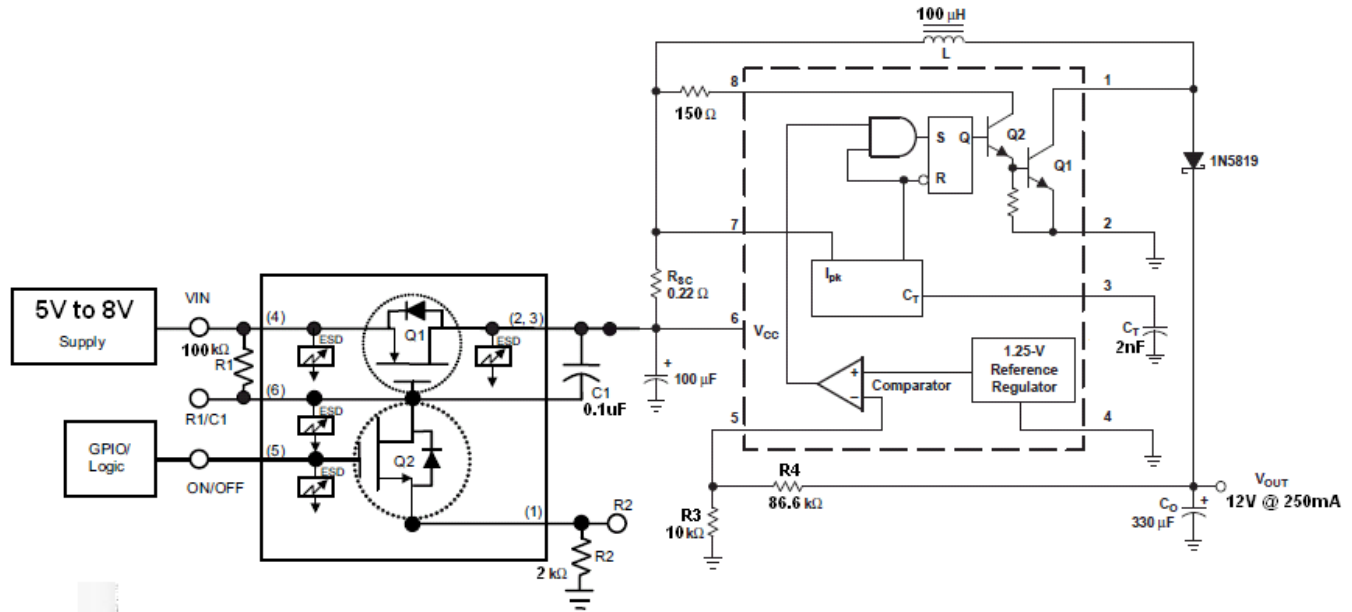

Using a load switch as a shutdown control is common solution that works for any regulator. It is included here because raising Cii voltage is only partially effective for shutdown of a boost topology switch regulator circuit.

The standard boost regulator circuit has an external path from MC34063A VCC pin to VOUT; therefore a load switch is required to break the path from input voltage to output voltage. The TPS27081A load switch is used to turn the supply voltage to the MC34063A on and off with a controlled slew rate that limits the peak current into the 100µF capacitor during turn on. A load switch can also be used for the buck and inverting applications.

This method provides a true shut down implementation. In addition to turning off the output, the total off current with 0V on the TPS27081A ON/OFF pin is less than 1µA.

Conclusion

Disabling the internal power switch by external raising the comparator inverting input voltage effectively shuts down the output voltage for buck and inverting (buck/boost) topologies. It also reduces the output voltage in a boost topology to one diode drop below V_{IN} . Only one or two additional components are needed to interface to logic outputs in a wide range of logic levels. The MC34063A bias current and feedback resistors still consume a few milli-amperes of current because the most of the MC34063A internal circuitry is still active. If this shutdown current draw is unacceptable then a load switch or different regulator with integrated shutdown should be used.

IMPORTANT NOTICE

Texas Instruments Incorporated and its subsidiaries (TI) reserve the right to make corrections, enhancements, improvements and other changes to its semiconductor products and services per JESD46, latest issue, and to discontinue any product or service per JESD48, latest issue. Buyers should obtain the latest relevant information before placing orders and should verify that such information is current and complete. All semiconductor products (also referred to herein as "components") are sold subject to TI's terms and conditions of sale supplied at the time of order acknowledgment.

TI warrants performance of its components to the specifications applicable at the time of sale, in accordance with the warranty in TI's terms and conditions of sale of semiconductor products. Testing and other quality control techniques are used to the extent TI deems necessary to support this warranty. Except where mandated by applicable law, testing of all parameters of each component is not necessarily performed.

TI assumes no liability for applications assistance or the design of Buyers' products. Buyers are responsible for their products and applications using TI components. To minimize the risks associated with Buyers' products and applications, Buyers should provide adequate design and operating safeguards.

TI does not warrant or represent that any license, either express or implied, is granted under any patent right, copyright, mask work right, or other intellectual property right relating to any combination, machine, or process in which TI components or services are used. Information published by TI regarding third-party products or services does not constitute a license to use such products or services or a warranty or endorsement thereof. Use of such information may require a license from a third party under the patents or other intellectual property of the third party, or a license from TI under the patents or other intellectual property of TI.

Reproduction of significant portions of TI information in TI data books or data sheets is permissible only if reproduction is without alteration and is accompanied by all associated warranties, conditions, limitations, and notices. TI is not responsible or liable for such altered documentation. Information of third parties may be subject to additional restrictions.

Resale of TI components or services with statements different from or beyond the parameters stated by TI for that component or service voids all express and any implied warranties for the associated TI component or service and is an unfair and deceptive business practice. TI is not responsible or liable for any such statements.

Buyer acknowledges and agrees that it is solely responsible for compliance with all legal, regulatory and safety-related requirements concerning its products, and any use of TI components in its applications, notwithstanding any applications-related information or support that may be provided by TI. Buyer represents and agrees that it has all the necessary expertise to create and implement safeguards which anticipate dangerous consequences of failures, monitor failures and their consequences, lessen the likelihood of failures that might cause harm and take appropriate remedial actions. Buyer will fully indemnify TI and its representatives against any damages arising out of the use of any TI components in safety-critical applications.

In some cases, TI components may be promoted specifically to facilitate safety-related applications. With such components, TI's goal is to help enable customers to design and create their own end-product solutions that meet applicable functional safety standards and requirements. Nonetheless, such components are subject to these terms.

No TI components are authorized for use in FDA Class III (or similar life-critical medical equipment) unless authorized officers of the parties have executed a special agreement specifically governing such use.

Only those TI components which TI has specifically designated as military grade or "enhanced plastic" are designed and intended for use in military/aerospace applications or environments. Buyer acknowledges and agrees that any military or aerospace use of TI components which have **not** been so designated is solely at the Buyer's risk, and that Buyer is solely responsible for compliance with all legal and regulatory requirements in connection with such use.

TI has specifically designated certain components as meeting ISO/TS16949 requirements, mainly for automotive use. In any case of use of non-designated products, TI will not be responsible for any failure to meet ISO/TS16949.

Products

Audio	www.ti.com/audio
Amplifiers	amplifier.ti.com
Data Converters	dataconverter.ti.com
DLP® Products	www.dlp.com
DSP	dsp.ti.com
Clocks and Timers	www.ti.com/clocks
Interface	interface.ti.com
Logic	logic.ti.com
Power Mgmt	power.ti.com
Microcontrollers	microcontroller.ti.com
RFID	www.ti-rfid.com
OMAP Applications Processors	www.ti.com/omap
Wireless Connectivity	www.ti.com/wirelessconnectivity

Applications

Automotive and Transportation	www.ti.com/automotive
Communications and Telecom	www.ti.com/communications
Computers and Peripherals	www.ti.com/computers
Consumer Electronics	www.ti.com/consumer-apps
Energy and Lighting	www.ti.com/energy
Industrial	www.ti.com/industrial
Medical	www.ti.com/medical
Security	www.ti.com/security
Space, Avionics and Defense	www.ti.com/space-avionics-defense
Video and Imaging	www.ti.com/video

TI E2E Community

e2e.ti.com