

ISOW7841A-Q1 Functional Safety FIT Rate, FMD and Pin FMA



Vikas Kumar Thawani

Table of Contents

1 Overview	2
2 Functional Safety Failure In Time (FIT) Rates	3
2.1 16-DW Package.....	3
3 Failure Mode Distribution (FMD)	4
4 Pin Failure Mode Analysis (Pin FMA)	5
4.1 16-DW (wide-body SOIC) Package.....	5

Trademarks

All trademarks are the property of their respective owners.

1 Overview

This document contains information for ISOW7841A-Q1 (16-DW package) to aid in a functional safety system design. Information provided are:

- Functional Safety Failure In Time (FIT) rates of the semiconductor component estimated by the application of industry reliability standards
- Component failure modes and their distribution (FMD) based on the primary function of the device
- Pin failure mode analysis (Pin FMA)

Figure 1-1 shows the device functional block diagram for reference.

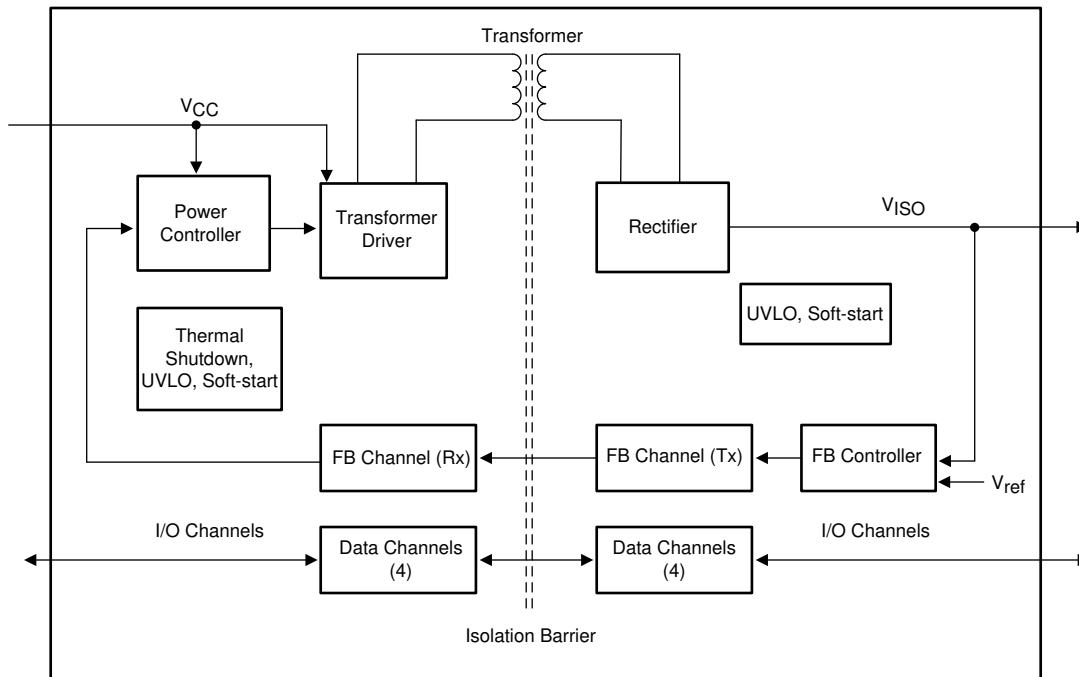

Figure 1-1. Functional Block Diagram

ISOW7841A-Q1 was developed using a quality-managed development process, but was not developed in accordance with the IEC 61508 or ISO 26262 standards.

2 Functional Safety Failure In Time (FIT) Rates

2.1 16-DW Package

This section provides Functional Safety Failure In Time (FIT) rates for 16-DW package of ISOW7841A-Q1 based on two different industry-wide used reliability standards:

- [Table 2-1](#) provides FIT rates based on IEC TR 62380 / ISO 26262 part 11
- [Table 2-2](#) provides FIT rates based on the Siemens Norm SN 29500-2

Table 2-1. Component Failure Rates per IEC TR 62380 / ISO 26262 Part 11

FIT IEC TR 62380 / ISO 26262	FIT (Failures Per 10 ⁹ Hours)
Total Component FIT Rate	36
Die FIT Rate	7
Package FIT Rate	29

The failure rate and mission profile information in [Table 2-1](#) comes from the Reliability data handbook IEC TR 62380 / ISO 26262 part 11:

- Mission Profile: Motor Control from Table 11
- Power dissipation: 1000 mW
- Climate type: World-wide Table 8
- Package factor (lambda 3): Table 17b
- Substrate Material: FR4
- EOS FIT rate assumed: 0 FIT

Table 2-2. Component Failure Rates per Siemens Norm SN 29500-2

Table	Category	Reference FIT Rate	Reference Virtual T _J
5	CMOS, BICMOS Digital, analog / mixed	60 FIT	70 °C

The Reference FIT Rate and Reference Virtual T_J (junction temperature) in [Table 2-2](#) come from the Siemens Norm SN 29500-2 tables 1 through 5. Failure rates under operating conditions are calculated from the reference failure rate and virtual junction temperature using conversion information in SN 29500-2 section 4.

3 Failure Mode Distribution (FMD)

The failure mode distribution estimation for ISOW7841A-Q1 in [Table 3-1](#) comes from the combination of common failure modes listed in standards such as IEC 61508 and ISO 26262, the ratio of sub-circuit function size and complexity and from best engineering judgment.

The failure modes listed in this section reflect random failure events and do not include failures due to misuse or overstress.

Table 3-1. Die Failure Modes and Distribution

Die Failure Modes	Failure Mode Distribution (%)
Isolated output supply V_{ISO} not in voltage or timing specification	50%
Isolated output supply V_{ISO} no output	21%
OUT not in timing or voltage specification	12%
OUT stuck to default state	9%
OUT state undetermined	5%
OUT stuck to non default state	1%
OUT stuck high	1%
OUT stuck low	1%

The FMD in [Table 3-1](#) excludes short circuit faults across the isolation barrier. Faults for short circuit across the isolation barrier can be excluded according to ISO 61800-5-2:2016 if the following requirements are fulfilled:

1. The signal isolation component is OVC III according to IEC 61800-5-1. If a SELV/PELV power supply is used, pollution degree 2/OVC II applies. All requirements of IEC 61800-5-1:2007, 4.3.6 apply.
2. Measures are taken to ensure that an internal failure of the signal isolation component cannot result in excessive temperature of its insulating material.

Creepage and clearance requirements should be applied according to the specific equipment isolation standards of an application. Care should be taken to maintain the creepage and clearance distance of a board design to ensure that the mounting pads of the isolator on the printed-circuit board do not reduce this distance.

4 Pin Failure Mode Analysis (Pin FMA)

This section provides a Failure Mode Analysis (FMA) for the pins of the ISOW7841A-Q1 in 16-SOIC package. The failure modes covered in this document include the typical pin-by-pin failure scenarios:

- Pin short-circuited to Ground (see [Table 4-2](#))
- Pin open-circuited (see [Table 4-3](#))
- Pin short-circuited to an adjacent pin (see [Table 4-4](#))
- Pin short-circuited to supply (see [Table 4-5](#))

[Table 4-2](#) through [Table 4-5](#) also indicate how these pin conditions can affect the device as per the failure effects classification in [Table 4-1](#). Note that when pin short to ground case is discussed, only same side ground shorts are considered.

Table 4-1. TI Classification of Failure Effects

Class	Failure Effects
A	Potential device damage that affects functionality
B	No device damage, but loss of functionality
C	No device damage, but performance degradation
D	No device damage, no impact to functionality or performance

4.1 16-DW (wide-body SOIC) Package

[Figure 4-1](#) shows the ISOW7841A-Q1 pin diagram for the 16-DW package. For a detailed description of the device pins please refer to the *Pin Configuration and Functions* section in the ISOW7841A-Q1 data sheet.

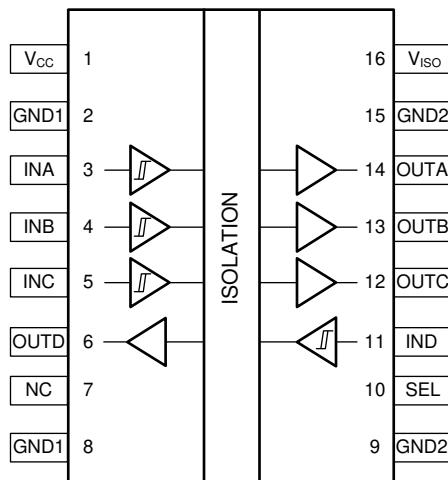

Figure 4-1. Pin Diagram (16-DW) Package

Table 4-2. Pin FMA for Device Pins Short-Circuited to Ground

Pin Name	Pin No.	Description of Potential Failure Effect(s)	Failure Effect Class
V _{CC}	1	No power to the device on side-1. Observe that the absolute maximum ratings for all pins of the device are met; otherwise device damage may be plausible. OUTx states undetermined.	A
GND1	2	Device continues to function as expected. Normal operation.	D
INA	3	Input signal shorted to ground, so output (OUTA) stuck to low. Communication from INA to OUTA corrupted.	B
INB	4	Input signal shorted to ground, so output (OUTB) stuck to low. Communication from INB to OUTB corrupted.	B
INC	5	Input signal shorted to ground, so output (OUTC) stuck to low. Communication from INC to OUTC corrupted.	B
OUTD	6	OUTD stuck low. Data communication from IND to OUTD lost. Device damage possible if IND is driven high for extended period of time.	A
NC	7	Device continues to function as expected. Normal operation.	D
GND1	8	Device continues to function as expected. Normal operation.	D
GND2	9	Device continues to function as expected. Normal operation.	D
SEL	10	If SEL is shorted on PCB to V _{ISO} to make V _{ISO} =5V and this failure shorts SEL to GND2, V _{ISO} will see hard-short at its output causing the power converter to go to short-circuit protection mode.	B
IND	11	Input signal shorted to ground, so output (OUTD) stuck to low. Communication from IND to OUTD corrupted.	B
OUTC	12	OUTC stuck low. Data communication from INC to OUTC lost. If INC is driven high, this failure can create short circuit of V _{ISO} to GND2.	B
OUTB	13	OUTB stuck low. Data communication from INB to OUTB lost. If INB is driven high, this failure can create short circuit of V _{ISO} to GND2.	B
OUTA	14	OUTA stuck low. Data communication from INA to OUTA lost. If INA is driven high, this failure can create short circuit of V _{ISO} to GND2.	B
GND2	15	Device continues to function as expected. Normal operation.	D
V _{ISO}	16	No power to the device on side-2. V _{ISO} shorted to GND2 will cause power converter to go to short circuit protection mode.	B

Table 4-3. Pin FMA for Device Pins Open-Circuited

Pin Name	Pin No.	Description of Potential Failure Effect(s)	Failure Effect Class
V _{CC}	1	Operation undetermined. Either device is unpowered and OUTx undetermined or through internal ESD diode on INA/INB/INC pin, device can power up if any IN is driven to logic high and has sourcing capability. ESD diode from IN to V _{CC} conducts the regular operating current, hence device damage plausible.	A
GND1	2	Device gets return ground through pin8. Some performance degradation such as increased radiated emissions possible.	C
INA	3	No communication to INA channel possible. OUTA stuck to default state (High for ISOW7841A-Q1 and Low for ISOW7841FA-Q1).	B
INB	4	No communication to INB channel possible. OUTB stuck to default state (High for ISOW7841A-Q1 and Low for ISOW7841FA-Q1).	B
INC	5	No communication to INC channel possible. OUTC stuck to default state (High for ISOW7841A-Q1 and Low for ISOW7841FA-Q1).	B
OUTD	6	State of OUTD undetermined. Data communication from IND to OUTD lost.	B
NC	7	Device continues to function as expected. Normal operation.	D
GND1	8	Device gets return ground through pin2. Normal operation.	D
GND2	9	Device gets return ground through pin15. Normal operation.	D
SEL	10	V _{ISO} defaults to 3.3V (due to chip internal pull-down).	B
IND	11	No communication to IND channel possible. OUTD stuck to default state (High for ISOW7841A-Q1 and Low for ISOW7841FA-Q1).	B
OUTC	12	State of OUTC undetermined. Data communication from INC to OUTC lost.	B

Table 4-3. Pin FMA for Device Pins Open-Circuited (continued)

Pin Name	Pin No.	Description of Potential Failure Effect(s)	Failure Effect Class
OUTB	13	State of OUTB undetermined. Data communication from INB to OUTB lost.	B
OUTA	14	State of OUTA undetermined. Data communication from INA to OUTA lost.	B
GND2	15	Device gets return ground through pin9. Some performance degradation such as increased radiated emissions possible.	C
V _{ISO}	16	V _{ISO} supply to external components on PCB turned off.	B

Table 4-4. Pin FMA for Device Pins Short-Circuited to Adjacent Pin

Pin Name	Pin No.	Shorted to	Description of Potential Failure Effect(s)	Failure Effect Class
V _{CC}	1	GND1	No power to the device on side-1 and side-2. Observe that the absolute maximum ratings for all pins of the device are met; otherwise device damage may be plausible.	A
GND1	2	INA	Input signal shorted to ground, so output (OUTA) stuck to low. Communication from INA to OUTA corrupted.	B
INA	3	INB	Communication corrupted for either INA or INB channel.	B
INB	4	INC	Communication corrupted for either INC or INB channel.	B
INC	5	OUTD	Communication corrupted for either or both channels. With opposite logic state on both channels, high current can flow between supply and ground and cause possible device damage.	A
OUTD	6	NC	Device continues to function as expected. Normal operation.	D
NC	7	GND1	Device continues to function as expected. Normal operation.	D
GND1	8	NC	Already considered in above row.	D
GND2	9	SEL	If SEL is shorted on PCB to V _{ISO} to make V _{ISO} =5V and this failure shorts SEL to GND2, V _{ISO} will see hard-short at its output causing the power converter to go to short-circuit protection mode.	B
SEL	10	IND	Communication corrupted on Channel D because SEL will be pulled high or low externally.	B
IND	11	OUTC	Communication corrupted for either or both channels. With opposite logic state on both channels, high current can flow between V _{ISO} and GND2 and cause device into short circuit protection mechanism.	B
OUTC	12	OUTB	Communication corrupted for either or both channels. With opposite logic state on both channels, high current can flow between V _{ISO} and GND2 and cause device into short circuit protection mechanism.	B
OUTB	13	OUTA	Communication corrupted for either or both channels. With opposite logic state on both channels, high current can flow between V _{ISO} and GND2 and cause device into short circuit protection mechanism.	B
OUTA	14	GND2	OUTA stuck low. Data communication from INA to OUTA lost. If INA is driven high for extended period of time, V _{ISO} to GND2 short can cause device into short circuit protection mechanism.	B
GND2	15	V _{ISO}	No power to the device on side-2. V _{ISO} to GND2 short can cause device into short circuit protection mechanism.	B
V _{ISO}	16	GND2	Already considered in above row.	B

Table 4-5. Pin FMA for Device Pins Short-Circuited to supply

Pin Name	Pin No.	Description of Potential Failure Effect(s)	Failure Effect Class
V _{CC}	1	No effect. Normal operation.	D
GND1	2	This will create supply to ground short on PCB causing the device to turn off.	B
INA	3	INA pin stuck high. Communication corrupted. OUTA state high.	B
INB	4	INB pin stuck high. Communication corrupted. OUTB state high.	B
INC	5	INC pin stuck high. Communication corrupted. OUTC state high.	B
OUTD	6	OUTD stuck high. Data communication from INC to OUTC lost. Device damage possible if IND is driven low for extended period of time causing a short between supply and ground on side-1.	A
NC	7	Device continues to function as expected. Normal operation.	D
GND1	8	This will create supply to ground short on PCB causing the device to turn off.	B
GND2	9	This will cause V _{ISO} to ground short making the device go in short circuit protection mode.	B
SEL	10	V _{ISO} permanently set to 5V. 3.3V output supply no longer achievable. Also if SEL grounded (V _{ISO} = 3.3 V) was the use case, this failure will create V _{ISO} to ground short.	B

Table 4-5. Pin FMA for Device Pins Short-Circuited to supply (continued)

Pin Name	Pin No.	Description of Potential Failure Effect(s)	Failure Effect Class
IND	11	IND pin stuck high. Communication corrupted. OUTD state high.	B
OUTC	12	OUTC stuck high. Communication disrupted. If INC is low for extended duration, OUTC being stuck high creates a short and can cause device go to short circuit protection mechanism.	B
OUTB	13	OUTB stuck high. Communication disrupted. If INB is low for extended duration, OUTB being stuck high creates a short and can cause device go to short circuit protection mechanism.	B
OUTA	14	OUTA stuck high. Communication disrupted. If INA is low for extended duration, OUTA being stuck high creates a short and can cause device go to short circuit protection mechanism.	B
GND2	15	This will cause V_{ISO} to ground short making the device go in short circuit protection mode.	B
V_{ISO}	16	Device continues to function as expected. Normal operation.	D

IMPORTANT NOTICE AND DISCLAIMER

TI PROVIDES TECHNICAL AND RELIABILITY DATA (INCLUDING DATASHEETS), DESIGN RESOURCES (INCLUDING REFERENCE DESIGNS), APPLICATION OR OTHER DESIGN ADVICE, WEB TOOLS, SAFETY INFORMATION, AND OTHER RESOURCES "AS IS" AND WITH ALL FAULTS, AND DISCLAIMS ALL WARRANTIES, EXPRESS AND IMPLIED, INCLUDING WITHOUT LIMITATION ANY IMPLIED WARRANTIES OF MERCHANTABILITY, FITNESS FOR A PARTICULAR PURPOSE OR NON-INFRINGEMENT OF THIRD PARTY INTELLECTUAL PROPERTY RIGHTS.

These resources are intended for skilled developers designing with TI products. You are solely responsible for (1) selecting the appropriate TI products for your application, (2) designing, validating and testing your application, and (3) ensuring your application meets applicable standards, and any other safety, security, or other requirements. These resources are subject to change without notice. TI grants you permission to use these resources only for development of an application that uses the TI products described in the resource. Other reproduction and display of these resources is prohibited. No license is granted to any other TI intellectual property right or to any third party intellectual property right. TI disclaims responsibility for, and you will fully indemnify TI and its representatives against, any claims, damages, costs, losses, and liabilities arising out of your use of these resources.

TI's products are provided subject to TI's Terms of Sale (www.ti.com/legal/termsofsale.html) or other applicable terms available either on ti.com or provided in conjunction with such TI products. TI's provision of these resources does not expand or otherwise alter TI's applicable warranties or warranty disclaimers for TI products.

Mailing Address: Texas Instruments, Post Office Box 655303, Dallas, Texas 75265
Copyright © 2020, Texas Instruments Incorporated