

Using the UCG28826EVM-093 65W USB-C PD High-Density GaN Integrated Quasi-Resonant Flyback Converter



Description

The UCG28826EVM-093 is a 65W USB-C PD evaluation module (EVM) for evaluating an off-line GaN integrated quasi-resonant flyback adapter for AC/DC adapters, chargers, USB wall outlets, and other applications. The EVM meets CoC Tier 2 and DoE Level 6 efficiency requirements. The EVM is intended for evaluation purposes and is not intended to be an end product. The UCG28826EVM-093 converts input voltage of $90V_{RMS}$ to $264V_{RMS}$ down to a selectable USB-C PD output voltage $20V_{DC}$, with a max 3.25A, and to $5V_{DC}$, $9V_{DC}$, and $15V_{DC}$, with a max 3.00A output current rating. The main device used in this design is the UCG28826 with integrated 650V GaN FET and controller in 5mm x 5mm package.

Get Started

1. Read and study this user's guide completely before evaluating
2. Order the [UCG28826EVM-093](#) for evaluation if step 1 met
3. Setup and test the [UCG28826EVM-093](#) per user's guide instructions

Features

- 93-95% Efficiency under full-load operation over entire input voltage range
- $2.8W/cm^3$ ($3.9cm \times 3.43cm \times 1.71cm$) Power density enabled by 140kHz maximum switching frequency
- Self-bias and auxless-sense, Integrated current sense, Integrated HV startup and Integrated X-cap discharge enable lowest BOM cost by integration
- Comprehensive protection features including OVP, OTP, Short circuit and overcurrent protection and brown-in/out protection
- USB-C output enables full system-level evaluation for end-equipments like adapters, notebook chargers, USB wall outlets

Applications

- USB-C PD power adapters
- AC-to-DC or DC-to-DC auxiliary power supplies
- High-density AC-to-DC converters / adapters for notebook computers, tablet computers, TV, and set-top box
- USB-C PPS power adapters



Figure 1-1. UCG28826EVM-093 (Top view)

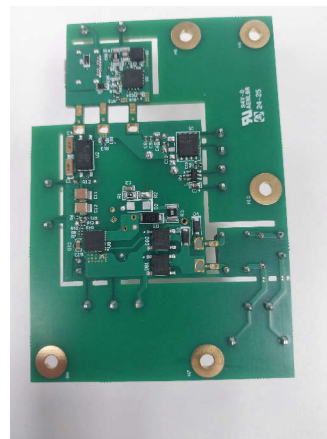

Figure 1-2. UCG28826EVM-093 (Bottom view)

1 Evaluation Module Overview

1.1 Introduction

The UCG28826EVM-093 facilitates the evaluation of UCG28826, Integrated GaN FET with controller, within an AC-DC QR flyback power converter. The EVM is designed for a universal AC input range of 90VAC-264VAC and follows the USB PD 3.0 output protocol of 20V/15V/9V/5V. This user guide provides a high-voltage safety overview, recommended test setup, resulting efficiency results, thermals, waveforms, and conducted EMI performance.

1.2 Kit Contents

- 65W USB-C QR Flyback Evaluation Module
- Quick Start Guide
- High Voltage Notice

1.3 Specification

Input	Output	Max Output Power
90VAC-264VAC 47-63Hz	20V/3.25A, 15V/3.00A, 9V/3.00A, 5V/3.00A	65W

1.4 Device Information

The UCG28826 is a high frequency, quasi-resonant (QR) AC/DC flyback converter with integrated 650V primary-side GaN FET suitable for use in power supplies up to 65W without PFC and 120W with a PFC front-end. This device gives benefit of GaN integration to achieve high power density designs with high switching frequency up to 500kHz. The UCG28826 features industry's first auxless flyback architecture with self-bias to give a compact and low cost power supply design without the need for an auxiliary winding in the transformer. The self bias feature reduces losses to improve efficiency in wide output voltage applications like USB-PD chargers by eliminating the need for a low dropout regulator (LDO) and its associated losses to generate the device bias. The UCG28826 supports continuous conduction mode (CCM) operation for upto 4msec for transient output power conditions of up to 130W (two times the 65W nominal output power) in low-line input conditions without the need for a transformer designed for such transient load conditions, saving space and cost. This device also includes frequency foldback and burst modes for higher efficiency operation during light load and no-load conditions, respectively. The X-cap discharge circuit discharges the X-capacitor in the input EMI filter to 0V within less than 1sec to prevent the user from an electric shock at the time of unplugging the power supply from the wall socket. The UCG28826 overcomes the system design limitations of integrated converters by offering resistor programmable options for maximum flexibility to user to optimize performance at the desired operating point. The device also includes many in-built protections to output over-voltage, over-current, overload, short-circuit and over-temperature conditions with auto-restart and latch response for a robust power supply design preventing any damage during such fault conditions.

1.5 General Texas Instruments High Voltage Evaluation (TI HV EVM) User Safety Guidelines



Always follow TI's setup and application instructions, including use of all interface components within the recommended electrical rated voltage and power limits. Always use electrical safety precautions to help ensure your personal safety and those working around you. Contact TI's Product Information Center <http://support/ti.com> for further information.

Save all warnings and instructions for future reference.

WARNING

Failure to follow warnings and instructions can result in personal injury, property damage or death due to electrical shock and burn hazards.

The term TI HV EVM refers to an electronic device typically provided as an open framed, unenclosed printed circuit board assembly. It is *intended strictly for use in development laboratory environments, solely for qualified professional users having training, expertise and knowledge of electrical safety risks in development and application of high voltage electrical circuits. Any other use and/or application are strictly prohibited by Texas Instruments.* If you are not qualified, then you should immediately stop from further use of the HV EVM.

1. Work Area Safety

- a. Keep work area clean and orderly.
- b. Qualified observers must be present anytime circuits are energized.
- c. Effective barriers and signage must be present in the area where the TI HV EVM and the interface electronics are energized, indicating operation of accessible high voltages can be present, for the purpose of protecting inadvertent access.
- d. All interface circuits, power supplies, evaluation modules, instruments, meters, scopes and other related apparatus used in a development environment exceeding 50Vrms/75VDC must be electrically located within a protected Emergency Power Off EPO protected power strip.
- e. Use stable and nonconductive work surface.
- f. Use adequately insulated clamps and wires to attach measurement probes and instruments. No freehand testing whenever possible.

2. Electrical Safety

As a precautionary measure, a good engineering practice is to assume that the entire EVM can have fully accessible and active high voltages.

- a. De-energize the TI HV EVM and all the inputs, outputs and electrical loads before performing any electrical or other diagnostic measurements. Revalidate that TI HV EVM power has been safely de-energized.
- b. With the EVM confirmed de-energized, proceed with required electrical circuit configurations, wiring, measurement equipment connection, and other application needs, while still assuming the EVM circuit and measuring instruments are electrically live.
- c. After EVM readiness is complete, energize the EVM as intended.

WARNING

While the EVM is energized, never touch the EVM or the electrical circuits, as the EVM or the electrical circuits can be at high voltages capable of causing electrical shock hazard.

3. Personal Safety

- a. Wear personal protective equipment (for example, latex gloves or safety glasses with side shields) or protect EVM in an adequate lucent plastic box with interlocks to protect from accidental touch.

Limitation for safe use:

EVMs are not to be used as all or part of a production unit.

2 Hardware

2.1 Additional Images

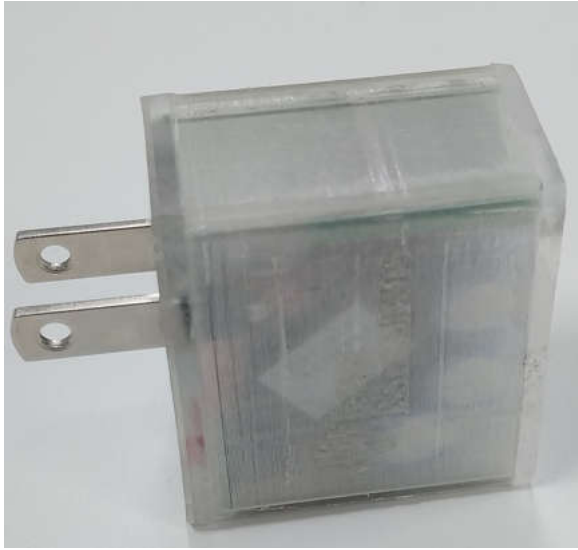

Figure 2-1. Adapter Configuration

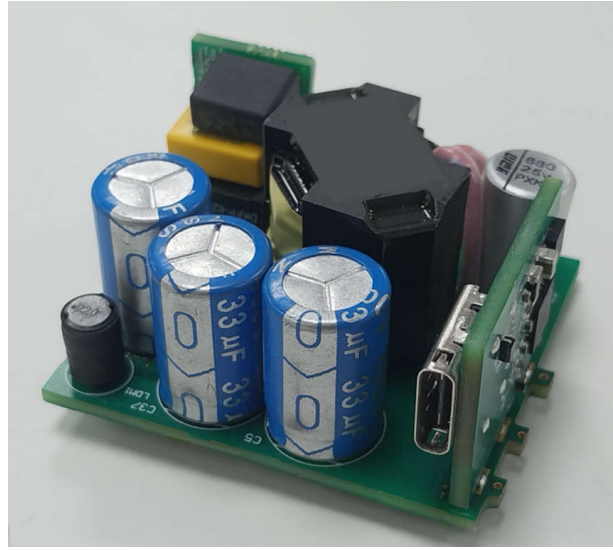

Figure 2-2. High-Density Configuration

2.1.1 Using the EVM on a Load with USB-C PD Communication

UCG28826EVM-093 comes populated with a USB-C PD controller and requires external connection through an on-board USB-C connector to a USB-C PD load to adjust the board output to obtain 5V, 9V, 15V or 20V. A USB-C PD communicating load is required for board evaluation. An example of such a load is USB-C-PD-DUO-EVM. Without such a communication load, the board output USB-C connector (J2) does not provide a variable output voltage. To obtain the full load current 3.00A from 5V, 9V and 15V, a standard USB-C cable can be used. To obtain 3.25A at 20V output, an "E-marker" USB-C cable must be used.

2.1.2 Using the EVM on a Load Without USB-C PD Communication

Normally, a USB-C PD communicated load is required to make evaluation. Without a USB-C PD communication-based load, the board does not provide output voltage on USB-C (J2) connector. In such a case, the board output voltage can be obtained from C2, but the output will be limited to 5V and up to 3.00A.

3 Implementation Results

3.1 Electrical Performance Specifications

Table 3-1. UCC28826EVM-093 Electrical Performance Specifications

PARAMETER		TEST CONDITIONS	MIN	NOM	MAX	UNIT
INPUT CHARACTERISTICS						
V_{IN}	Input line voltage (RMS)		90	115 / 230	264	V
f_{LINE}	Input line frequency		47	50 / 60	63	Hz
P_{STBY}	Input power at no-load	$V_{IN} = 115/230V_{RMS}$, $I_{OUT} = 0A$		10/26		mW
$P_{0.18W}$	Input power at 0.18W load	$V_{IN} = 230V_{RMS}$, $P_{OUT} = 180mW$		270		mW
$P_{0.3W}$	Input power at 0.3W load	$V_{IN} = 230V_{RMS}$, $P_{OUT} = 300mW$		400		mW
OUTPUT CHARACTERISTICS						
V_{OUT}	Output voltage (USB-C PD) $V_{IN} = 90$ to $264V_{RMS}$	$I_{OUT} = 0$ to $3.25A$		19.950		V
				15.050		
		$I_{OUT} = 0$ to $3.00A$		9.050		
				5.050		
I_{OUT}	Full load rated output current $V_{IN} = 90$ to $264V_{RMS}$	$V_{OUT} = 20.0V$		3.250		A
		$V_{OUT} = 5.0, 9.0,$ or $15.0V$		3.000		
V_{OUT_PP}	Output ripple voltage ⁽²⁾ $V_{IN} = 115V / 230V_{RMS}$	$V_{OUT} = 20.0V$, $I_{OUT} = 0$ to $3.25A$ (Including switching noise)		420		mV pp
		$V_{OUT} = 15.0V$, $I_{OUT} = 0$ to $3.00A$ (Including switching noise)		380		
		$V_{OUT} = 9.0V$, $I_{OUT} = 0$ to $3.00A$ (Including switching noise)		280		
		$V_{OUT} = 5.0V$, $I_{OUT} = 0$ to $3.00A$ (Including switching noise)		200		
$V_{OUT_Δ}$	Output voltage deviation due to load step Up / Down (I_{OUT} step change between 0 and 100% load at 100Hz rate)	$V_{OUT} = 20.0V$		-660 / 500		mV pp
		$V_{OUT} = 15.0V$		-520 / 480		
		$V_{OUT} = 9.0V$		-490 / 460		
		$V_{OUT} = 5.0V$		-480 / 450		
P_{OUT_opp}	Over-power protection threshold	$V_{IN} = 90$ to $264V_{RMS}$		80		W

Table 3-1. UCC28826EVM-093 Electrical Performance Specifications (continued)

PARAMETER	TEST CONDITIONS	MIN	NOM	MAX	UNIT
SYSTEMS CHARACTERISTICS					
η Full-load efficiency ($V_{IN} = 115/230V_{RMS}$)	$V_{OUT} = 20V, I_{OUT} = 3.25A$	94.08 / 94.63			%
	$V_{OUT} = 15V, I_{OUT} = 3.00A$	93.88 / 94.31			
	$V_{OUT} = 9V, I_{OUT} = 3.00A$	93.66 / 93			
	$V_{OUT} = 5V, I_{OUT} = 3.00A$	92.8 / 91.67			
η 4-point average efficiency ⁽¹⁾ $V_{IN} = 115/230V_{RMS}$	$V_{OUT} = 20V$ (CoC Tier 2, 89.0%)	94.14 / 93.85			%
	$V_{OUT} = 15V$ (CoC Tier 2, 88.9%)	94.15 / 92.95			
	$V_{OUT} = 9V$ (CoC Tier 2, 87.3%)	93.6 / 91.64			
	$V_{OUT} = 5V$ (CoC Tier 2, 81.8%)	92.28 / 89.23			
η Efficiency at 10% Load $V_{IN} = 115/230 V_{RMS}$	$V_{OUT} = 20V$ (CoC Tier 2, 79.0%)	92.04 / 89.39			%
	$V_{OUT} = 15V$ (CoC Tier 2, 78.9%)	92.4 / 89.71			
	$V_{OUT} = 9V$ (CoC Tier 2, 77.3%)	92.6 / 89.29			
	$V_{OUT} = 5V$ (CoC Tier 2, 72.5%)	90.6 / 86.64			
T_{AMB} Ambient operating temperature range	$V_{IN} = 90$ to $264V_{RMS}$, $I_{OUT} = 0$ to $3.00A$ (5V/9V/15V), or $3.25A$ (20V)	25			°C

- (1) Average efficiency of four load points, $I_{OUT} = 100\%$, 75% , 50% and 25% of rated full-load current for each respective output voltage. Also the 4 point efficiency numbers are measured with MP6951 for better 9V & 5V performance. MP6908 and MP6951 are pin to pin and can be swapped on the EVM.
- (2) The voltage ripple numbers mentioned above include switching noise. Without this it is less than $150mV_{pp}$. Please refer section on "[Section 3.3.9](#)".

3.2 Test Setup

3.2.1 Test Setup Requirements

Safety: This evaluation module is not encapsulated and there are accessible voltages that are greater than 50V_{DC}.

Isolation Input Transformer: An appropriately rated 1:1 isolation transformer shall be used on the inputs to this EVM and be constructed in a manner in which the primary winding are separated from the secondary windings by reinforced insulation, double insulation, or a screen connected to the protective conductor terminal.



WARNING

- If the user is not trained in the proper safety of handling and testing power electronics, then please do not test this evaluation module.
- While the EVM is energized, never touch the EVM or the electrical circuits, as the EVM or the electrical circuits can be at high voltages capable of causing electrical shock hazard.
- Caution: Hot surface. Contact can cause burns. Do not touch!
- Read this user's guide thoroughly before making test.

Voltage Source: Isolated AC source or variable AC transformer capable of 264V_{RMS} and capable of handling 100W power level.

Voltmeter: Digital voltage meter

Power Analyzer: Capable of measuring 1mW to 100W of input power and capable of handling 264V_{RMS} input voltage. Some power analyzers may require a precision shunt resistor for measuring input current to measure input power of 5W or less. Please read the power analyzer's user manual for proper measurement setups for full power and for stand-by power.

Oscilloscope:

- 4 Channel, 500MHz bandwidth.
- Probes capable of handling 600V.

Output Load: Resistive or electronic load capable of handling 130W at 20V.

Recommended Wire Gauge: Insulated 22AWG to 18AWG.



WARNING

Caution: Do not leave EVM powered when unattended.

3.2.2 Test Setup Diagram

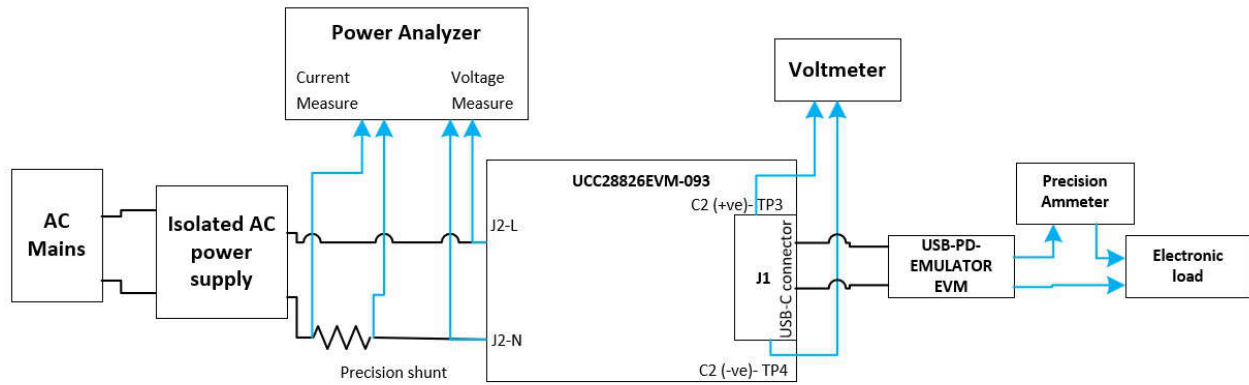

Figure 3-1. UCG28826EVM-093 Test Setup Diagram

The efficiency results for 25%-100% load are taken with the above configuration. For standby and 10% load the voltmeter is moved outside of the shunt to record efficiency numbers.

The following USB emulator "[USB-C-DUO EVM](#)" is used for evaluation purpose. It is important to note that this EVM consumes close to 10mA of current and this needs to be considered for efficiency calculation.

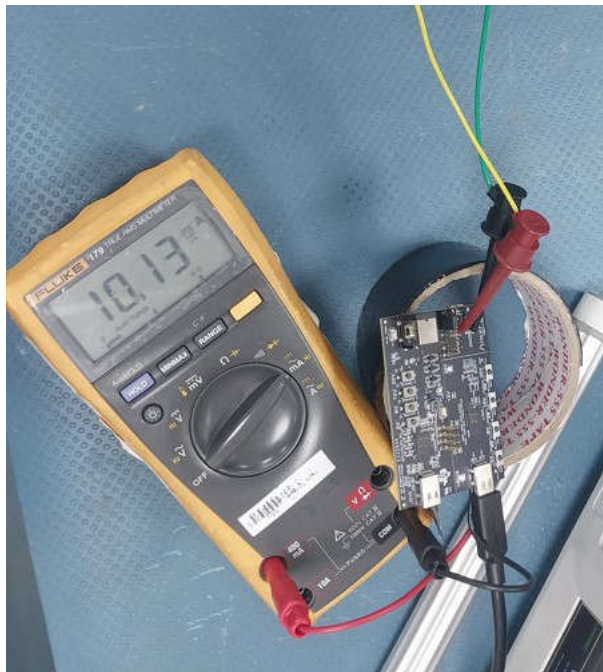

Figure 3-2. USB-C Emulator

3.2.3 Test Points

Table 3-2. Input/Output Terminals and Test Point Functions

Terminals and TEST POINTS		NAME	DESCRIPTION
J1	J1 Terminal	J1	USB-C
J2-L	J2 Terminal	L	AC voltage input - Line
J2-N		N	AC voltage input - Neutral
TPL	Input test points	TPL1	AC input monitor - Line
TPN	Input test points	TPN1	AC input monitor - Neutral
TP1	Bulk voltage	VBULK	Bulk voltage measurement point
TP5 , TP9	Power / Primary GND	PGND	Ground
TP6	Drain	VSW	Switch node voltage
TP8	Feedback	FB	Feedback pin voltage
TP2	Source	SRC	Source of SR FET
TP3	Drain	VOUT	Drain of SR FET
TP7	SR Gate	GATE	SR FET gate voltage pin
TP10	Output bus voltage	VBUS	Bus voltage at output side
TP11	Output return line	RTN	Return line at output side

3.3 Performance Data and Typical Characteristic Curves

3.3.1 Efficiency Result of 4-Point Average on 20V_{OUT}

V _{IN} (VRMS)	P _{IN} (W)	V _{OUT} (V)	I _{OUT} (A)	P _{OUT} (W)	P _{EMULATOR} (W)	P _{out} %	EFFICIENCY	4-PT AVERAGE EFFICIENCY
89.88	71.2	20.09	3.264	65.64	0.204	100%	92.48%	93.29%
89.91	52.94	20.08	2.451	49.214	0.2	75%	93.34%	
89.94	35.25	20.03	1.636	32.777	0.2	50%	93.55%	
89.98	17.76	20	0.823	16.46	0.2	25%	93.81%	
90.03	7.359	19.99	0.331	6.6193	0.2	10%	92.66%	
114.91	70	20.09	3.265	65.65	0.203	100%	94.08%	94.26%
114.94	52.5	20.08	2.452	449.235	0.203	75%	94.17%	
114.96	34.9	20.03	1.636	32.778	0.2	50%	94.49%	
115	17.68	20	0.824	16.474	0.2	25%	94.31%	
115.04	7.409	19.99	0.331	6.62	0.199	10%	92.04%	
229.98	69.6	20.08	3.265	65.662	0.2	100%	94.63%	93.83%
230.01	52.27	20.07	2.452	49.235	0.2	75%	94.58%	
230.01	35.06	20.02	1.636	32.778	0.2	50%	94.06%	
230.02	18.11	19.99	0.824	16.471	0.2	25%	92.05%	
230.08	7.63	19.98	0.331	6.6214	0.199	10%	89.39%	
264	69.71	20.08	3.266	65.684	0.2	100%	94.51%	93.29%
264	52.44	20.06	2.452	49.235	0.2	75%	94.27%	
264	35.25	20.03	1.636	32.678	0.2	50%	93.53%	
264.02	18.35	20	0.824	16.475	0.2	25%	90.87%	
264.1	7.705	19.98	0.331	6.62	0.199	10%	88.5%	
CoC Tier 2, 4-pt average								89.0%
CoC Tier 2, 10%-load								79.0%

3.3.2 Efficiency Result of 4-Point Average at 15V_{OUT}

V _{IN} (VRMS)	P _{IN} (W)	V _{OUT} (V)	I _{OUT} (A)	P _{OUT} (W)	P _{EMULATOR} (W)	P _{out} %	EFFICIENCY	4-PT AVERAGE EFFICIENCY
89.92	49.08	15.11	3.009	45.525	0.15	100%	93.06%	93.77%
89.95	36.55	15.09	2.259	34.088	0.148	75%	93.67%	
89.97	24.23	15.04	1.512	22.735	0.148	50%	94.44%	
89.99	12.28	15.02	0.758	11.384	0.15	25%	93.93%	
90.03	5.098	15.00	0.305	4.5789	0.148	10%	92.71%	
114.94	48.65	15.12	3.009	45.525	0.148	100%	93.88%	94.16%
114.95	36.32	15.09	2.26	34.105	0.15	75%	94.32%	
114.98	24.23	15.05	1.512	22.737	0.15	50%	94.46%	
115	12.272	15.02	0.758	11.382	0.15	25%	93.97%	
115.04	5.115	15.00	0.305	4.5776	0.149	10%	92.4%	
230	48.43	15.13	3.009	45.527	0.148	100%	94.31%	92.98%
230	36.44	15.08	2.26	34.088	0.148	75%	93.95%	
230	24.61	15.03	1.512	22.742	0.148	50%	93.01%	
230.02	12.72	15.01	0.758	11.382	0.148	25%	90.64%	
230.09	5.268	15.00	0.305	4.5757	0.15	10%	89.71%	
264	48.62	15.11	3.009	45.52	0.15	100%	93.93%	92%
264	36.66	15.08	2.259	34.101	0.148	75%	93.42%	
264.02	24.81	15.04	1.512	22.735	0.148	50%	92.23%	
264.04	13.04	15.02	0.759	11.383	0.148	25%	88.43%	
264.08	5.339	15.00	0.305	4.5779	0.148	10%	88.52%	
CoC Tier 2, 4-pt average								88.9%
CoC Tier 2, 10%-load								78.9%

3.3.3 Efficiency Result of 4-Point Average at 9V_{OUT}

V _{IN} (VRMS)	P _{IN} (W)	V _{OUT} (V)	I _{OUT} (A)	P _{OUT} (W)	P _{EMULATOR} (W)	P _{out} %	EFFICIENCY	4-PT AVERAGE EFFICIENCY
89.96	29.4	9.1	3.002	27.316	0.087	100%	93.21%	93.41%
89.98	21.98	9.08	2.249	20.424	0.087	75%	93.32%	
89.99	14.64	9.05	1.504	13.607	0.087	50%	93.54%	
90.0	7.368	9.01	0.755	6.8052	0.088	25%	93.56%	
90.03	3.043	8.99	0.305	2.7394	0.087	10%	92.89%	
114.98	29.25	9.09	3.001	27.307	0.087	100%	93.66%	93.62%
114.99	21.85	9.07	2.25	20.432	0.088	75%	93.92%	
115.0	14.59	9.05	1.503	13.601	0.087	50%	93.82%	
115.01	7.407	9.01	0.756	6.8077	0.088	25%	93.10%	
115.03	3.051	9.00	0.304	2.7368	0.088	10%	92.6%	
230.06	29.47	9.1	3.002	27.319	0.087	100%	93.0%	91.86%
230.06	22.13	9.08	2.249	20.42	0.089	75%	92.67%	
230.06	14.92	9.05	1.503	13.604	0.088	50%	91.77%	
230.06	7.66	9.01	0.755	6.8056	0.088	25%	90.0%	
230.08	3.165	8.99	0.305	2.739	0.087	10%	89.29%	
264.07	29.7	9.09	3.001	27.309	0.087	100%	92.24%	90.9%
264.07	22.34	9.06	2.249	20.42	0.087	75%	91.8%	
264.05	15.11	9.03	1.503	13.606	0.087	50%	90.62%	
264.05	7.747	9.01	0.755	6.803	0.087	25%	88.94%	
264.07	3.206	9.00	0.305	2.739	0.087	10%	88.15%	
CoC Tier 2, 4-pt average								87.3%
CoC Tier 2, 10%-load								77.3%

3.3.4 Efficiency Result of 4-Point Average at 5V_{OUT}

V _{IN} (VRMS)	P _{IN} (W)	V _{OUT} (V)	I _{OUT} (A)	P _{OUT} (W)	P _{EMULATOR} (W)	P _{out} %	EFFICIENCY	4-PT AVERAGE EFFICIENCY
89.99	16.63	5.09	2.994	15.242	0.048	100%	91.94%	92.26%
90	12.38	5.05	2.254	11.382	0.049	75%	92.33%	
90	8.223	5.01	1.51	7.5643	0.049	50%	92.58%	
90.02	4.151	4.99	0.757	3.7775	0.049	25%	92.17%	
90.03	1.723	4.97	0.306	1.5192	0.049	10%	90.99%	
115	16.55	5.09	2.995	15.243	0.048	100%	92.39%	92.28%
115	12.349	5.05	2.256	11.395	0.048	75%	92.66%	
115.01	8.251	5.01	1.51	7.5648	0.048	50%	92.26%	
115.01	4.167	4.99	0.757	3.7773	0.048	25%	91.18%	
115.03	1.731	4.97	0.306	1.5204	0.048	10%	90.6%	
230.04	16.77	5.08	2.994	15.242	0.049	100%	91.18%	89.23%
230.05	12.72	5.04	2.256	11.395	0.049	75%	89.97%	
230.06	8.62	5.01	1.512	7.5737	0.048	50%	88.42%	
230.06	4.381	4.99	0.757	3.7791	0.048	25%	87.35%	
230.08	1.811	4.97	0.306	1.5205	0.049	10%	86.64%	
264.04	16.96	5.08	2.998	15.258	0.048	100%	90.25%	87.82%
264.05	12.91	5.03	2.257	11.397	0.049	75%	88.66%	
264.07	8.79	5.01	1.51	7.5673	0.048	50%	86.64%	
264.07	4.462	4.99	0.757	3.777	0.048	25%	85.72%	
264.09	1.842	4.97	0.306	1.5192	0.048	10%	85.08%	
CoC Tier 2, 4-pt average								81.8%
CoC Tier 2, 10%-load								72.5%

Note

Please refer "Section 6" section for more efficiency results with a different power analyzer. This was done as the above readings showed some slight offset in the measured input current and hence low line efficiency numbers are marginally low.

3.3.5 Efficiency Typical Results

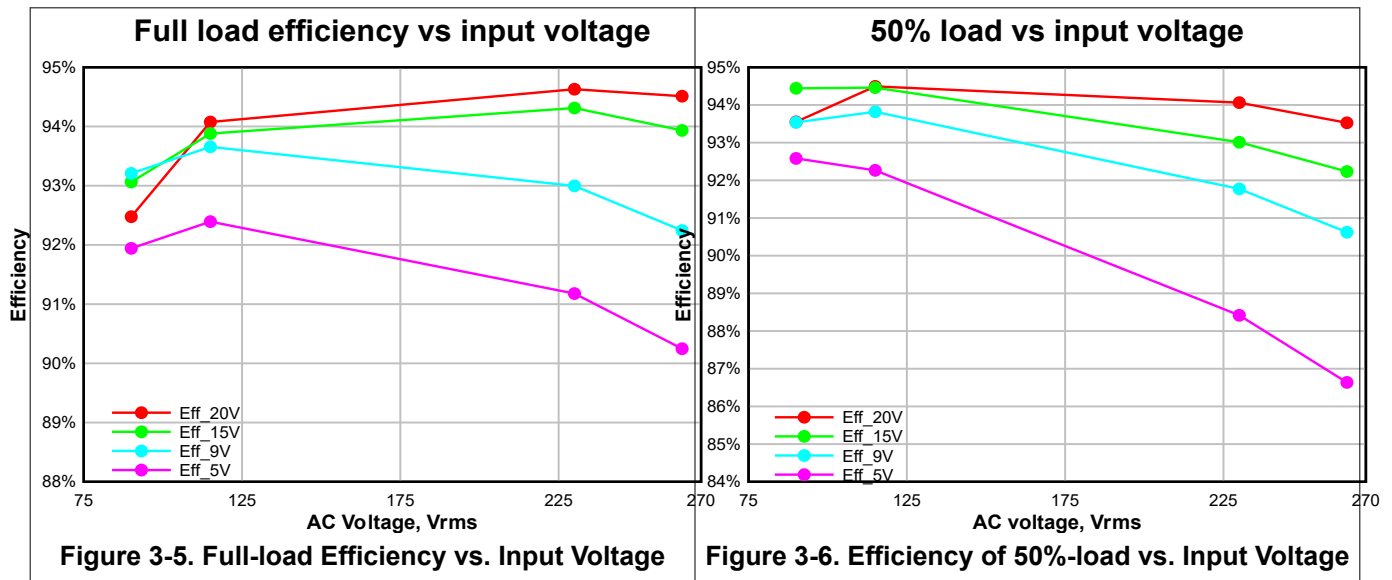
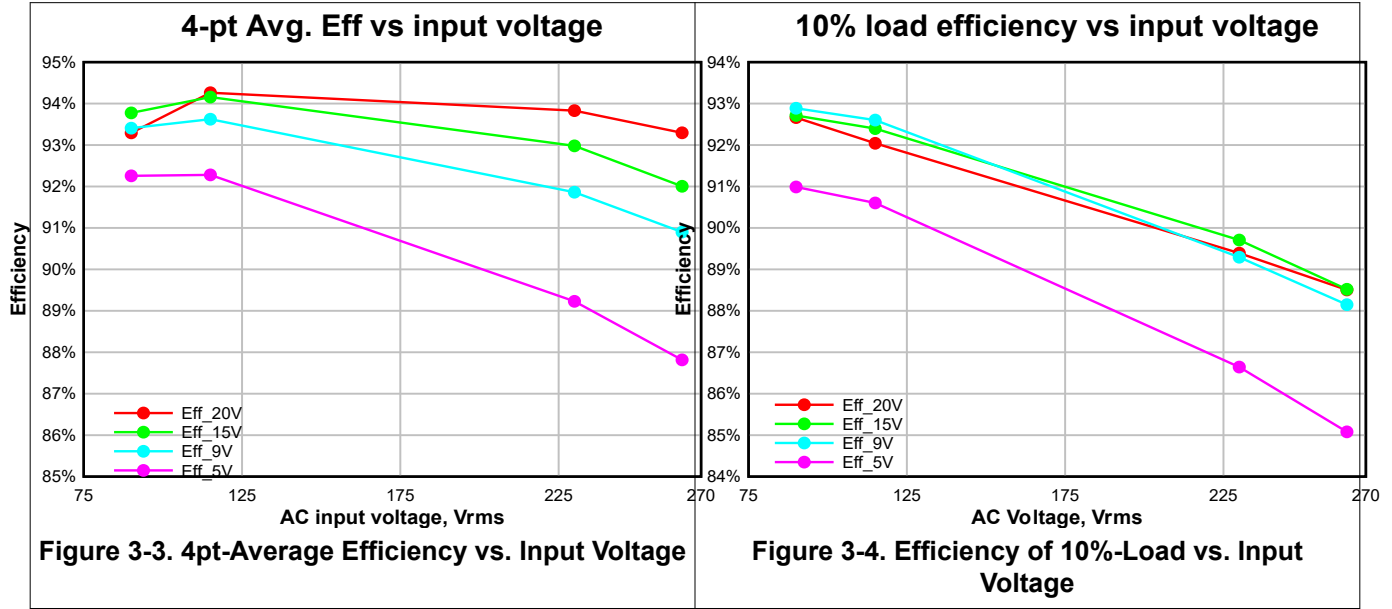

3.3.6 Output Characteristics

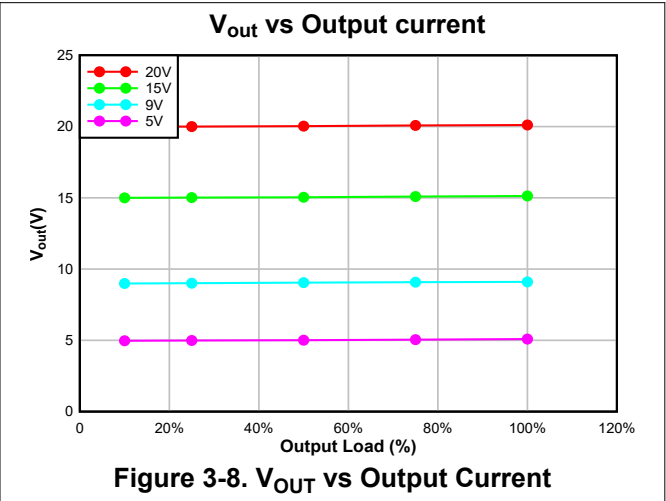
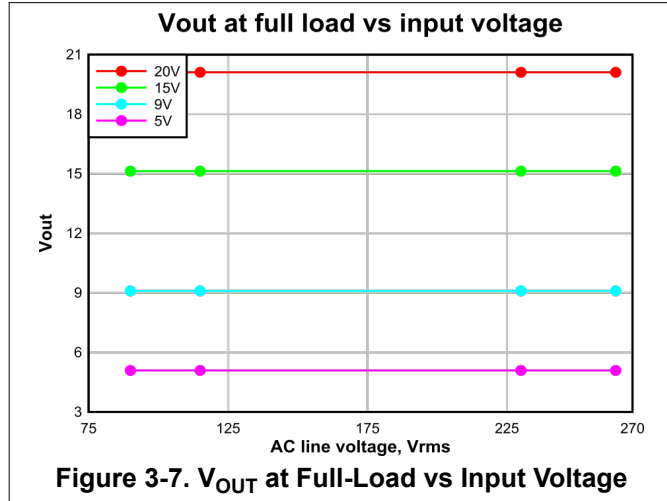

3.3.7 Key Switching Waveforms

This section (Figure 3-9 to Figure 3-24) shows typical switching waveforms at full load. YELLOW = Switch Node, BLUE = Output Voltage, BROWN - SR Gate voltage, RED - FB



Figure 3-9. Vin = 90Vac, Vout = 20V



Figure 3-10. Vin = 115Vac, Vout = 20V



Figure 3-11. Vin = 230Vac, Vout = 20V



Figure 3-12. Vin = 264Vac, Vout = 20V



Figure 3-13. Vin = 90Vac, Vout = 15V



Figure 3-14. Vin = 115Vac, Vout = 15V



Figure 3-15. Vin = 230Vac, Vout = 15V



Figure 3-16. Vin = 264Vac, Vout = 15V



Figure 3-17. Vin = 90Vac, Vout = 9V



Figure 3-18. Vin = 115Vac, Vout = 9V



Figure 3-19. Vin = 230Vac, Vout = 9V



Figure 3-20. Vin = 264Vac, Vout = 9V



Figure 3-21. Vin = 90Vac, Vout = 5V



Figure 3-22. Vin = 115Vac, Vout = 5V



Figure 3-23. Vin = 230Vac, Vout = 5V



Figure 3-24. Vin = 264Vac, Vout = 5V

3.3.8 Switching Frequency vs Load

This section shows typical switching waveforms at different load conditions. YELLOW = Switch Node, GREEN= Vbulk, PINK - Vfb

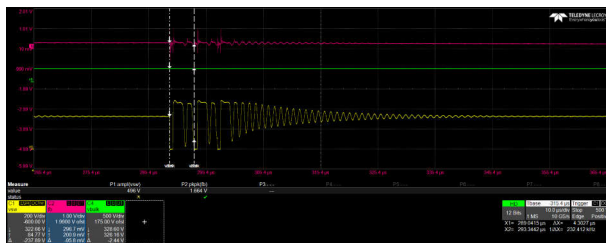

Figure 3-25. 230Vac/0.6W (240kHz burst frequency/ Vfb - 0.3V)

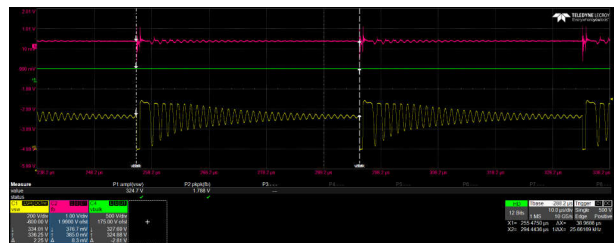

Figure 3-26. 230Vac/1.2W (25kHz frequency - foldback / Vfb - 0.35V)

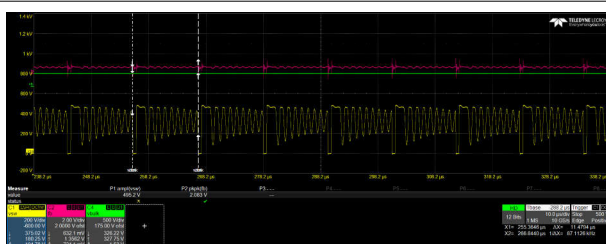

Figure 3-27. 230Vac/5.3W (87kHz frequency/ Vfb - 0.7V)

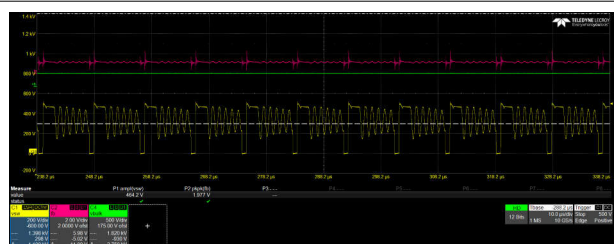

Figure 3-28. 230Vac/17W (113kHz frequency/ Vfb - 1.1V)

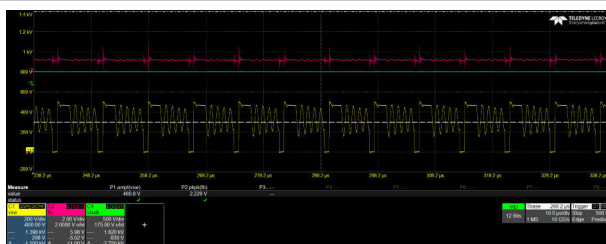

Figure 3-29. 230Vac/25W (125kHz frequency/ Vfb - 1.2V)

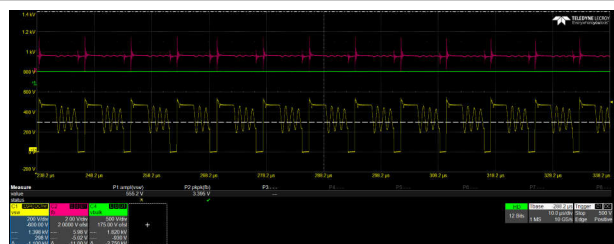

Figure 3-30. 230Vac/45W (130kHz frequency/ Vfb - 1.7V)

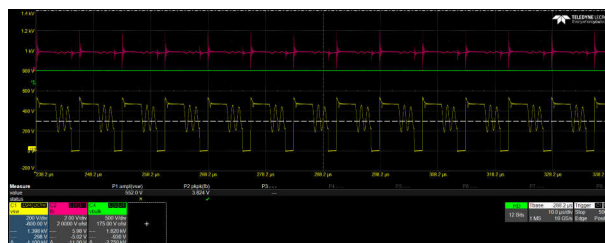

Figure 3-31. 230Vac/65W (140kHz frequency/ Vfb - 1.9V)

3.3.9 Output Ripple Voltage

Figure 3-32 to Figure 3-40 shows the output voltage ripple. Blue = Output Voltage Ripple, Oscilloscope Channel Bandwidth = 20MHz. The ripples are with the 100% load condition unless specified in the associated figures.

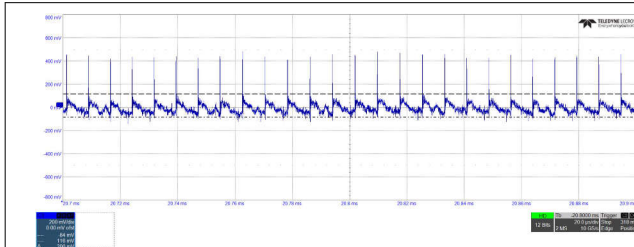

Figure 3-32. Typical Ripple Voltage of $V_{OUT} = 20V$ (420mVpp)

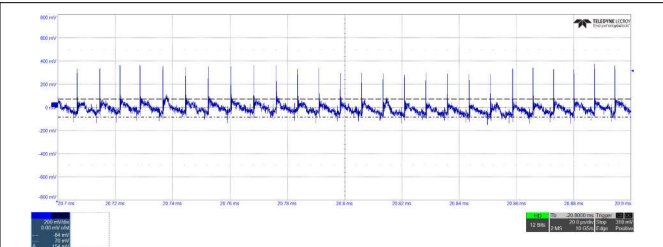

Figure 3-33. Typical Ripple Voltage of $V_{OUT} = 15V$ (380mVpp)

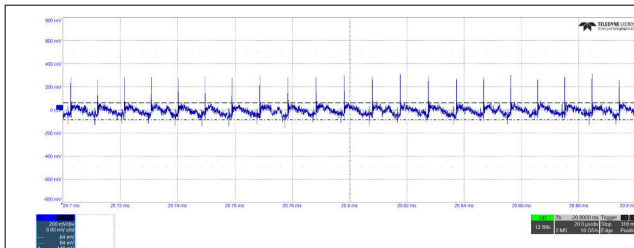

Figure 3-34. Typical Ripple Voltage of $V_{OUT} = 9V$ (280mVpp)

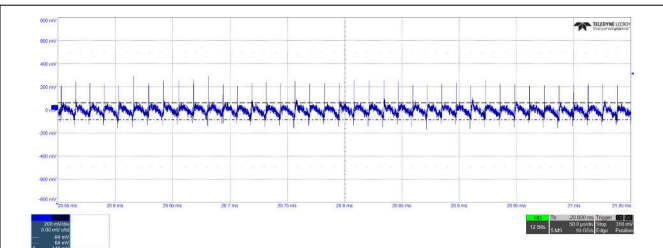

Figure 3-35. Typical Ripple Voltage of $V_{OUT} = 5V$ (200mVpp)

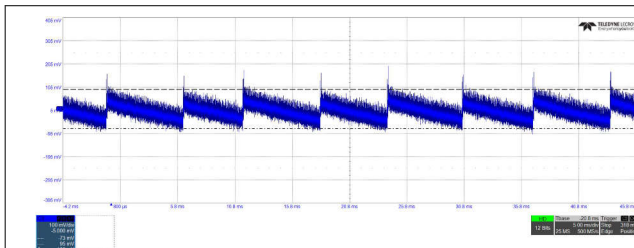

Figure 3-36. Typical Ripple Voltage of $V_{OUT} = 5V$ at No Load (168mVpp)

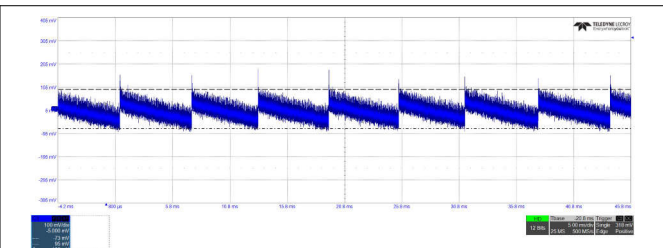

Figure 3-37. Typical Ripple Voltage of $V_{OUT} = 5V$ at No Load (168mVpp)

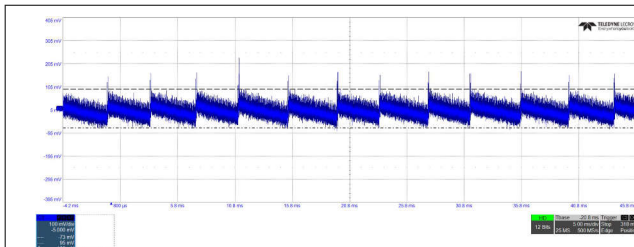

Figure 3-38. Typical Ripple Voltage of $V_{OUT} = 15V$ at No Load (168mVpp)

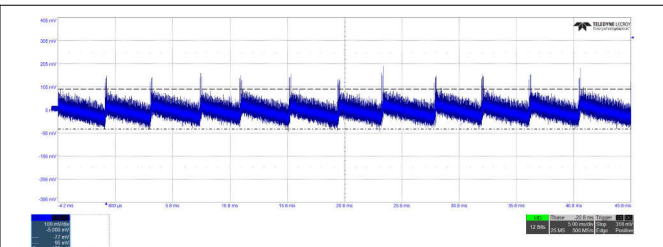

Figure 3-39. Typical Ripple Voltage of $V_{OUT} = 20V$ at No Load (168mVpp)

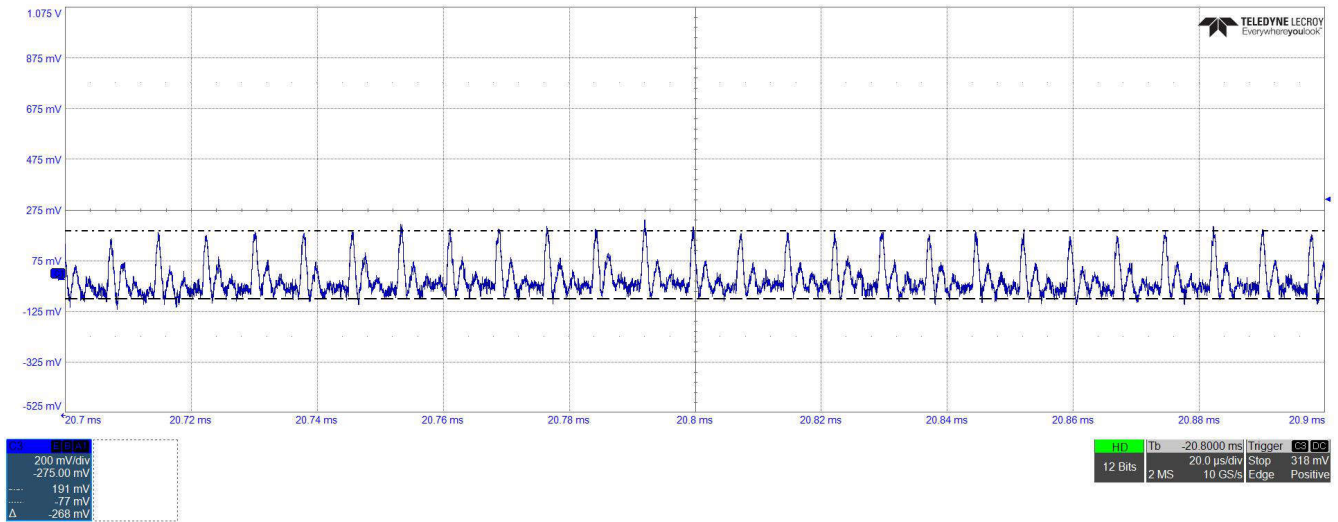

Figure 3-40. Typical Ripple Voltage of $V_{OUT} = 20V$ at Full Load (260mVpp)

3.3.10 Load Transient Response

Figure 3-41 to Figure 3-44 below show output voltage V_{OUT} deviation when load current step change is between 0 and 100%, at 100Hz rate at 2.5A/us. Note, the step load current is inverted in the capture.

Green (AC coupled)= V_{OUT} , Pink= Load Current.

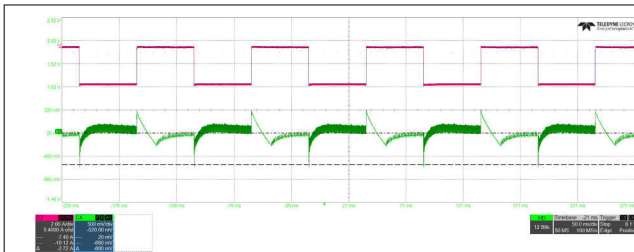

Figure 3-41. Load Transient Response at $V_{OUT} = 20V$ Overshoot / Undershoot = 495mV / -680mV

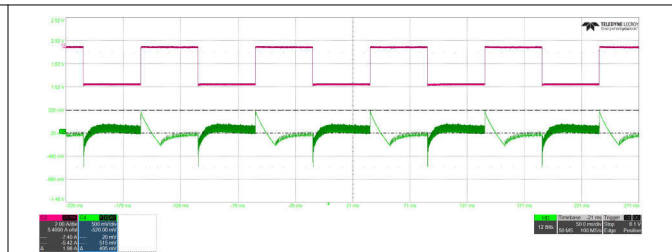

Figure 3-42. Transient Response at $V_{OUT} = 15V$ Overshoot / Undershoot = 485mV / -630mV

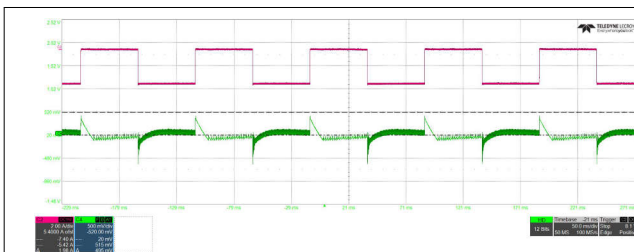

Figure 3-43. Transient Response at $V_{OUT} = 9V$ Overshoot / Undershoot = 460mV / -500mV

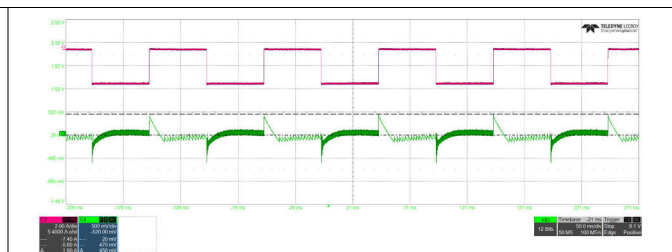

Figure 3-44. Transient Response at $V_{OUT} = 5V$ Overshoot / Undershoot = 440mV / -480mV

3.3.11 Line transient Response

Figure 3-45 and Figure 3-46 shows output voltage when line transient is applied from 90Vac to 264Vac at no load and full load.

RED - Output Voltage, BLACK - AC input, BLUE- Switch Node

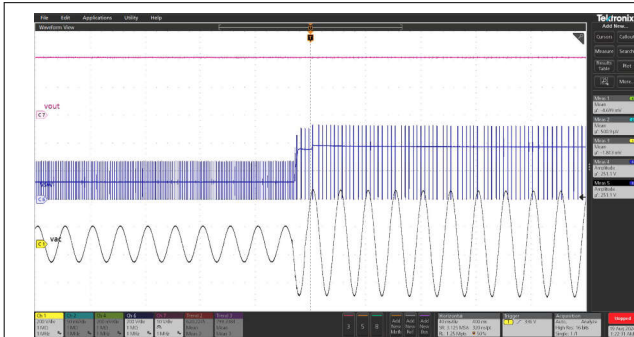

Figure 3-45. Line transient from 90Vac to 265Vac at 20V/No load

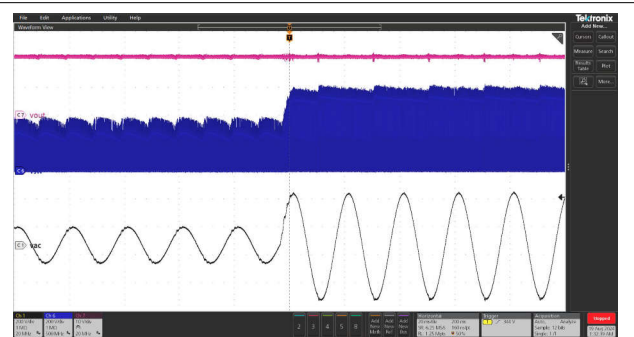

Figure 3-46. Line transient from 90Vac to 265Vac at 20V/Full load

3.3.12 Surge Test

Figure 3-47 and Figure 3-48 shows response when 2KV and 1KV surge is applied to the EVM with one positive impulse and a phase angle of 90 degrees

YELLOW - Bulk voltage, PURPLE - Switching Node Voltage



Figure 3-47. 2KV Surge at 230Vac input



Figure 3-48. 1KV Surge at 230Vac input

3.3.13 Short Term Overload Operation

The EVM is capable of supporting short term overload without damage, safety issues or triggering protection. The output voltage drops to 18V when peak short term overload of 6.5A is applied for 2ms (Figure 3-50) and also when 7.32A is applied for 1ms (Figure 3-49). The results are checked at 230Vac and 100Vac.

VSW = PINK, Load Current = GREEN, VOUT = BLUE, FB = YELLOW

The output voltage drops to approximately 18.2V

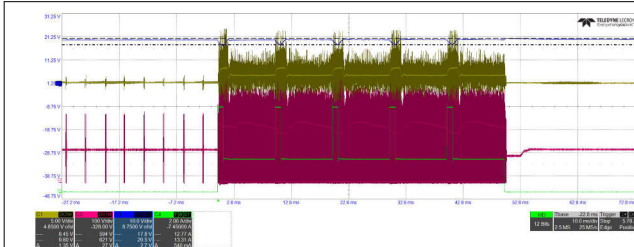

Figure 3-49. VIN=100Vac (2.25x rated current for 1ms, 0.9x rated current for 9ms)

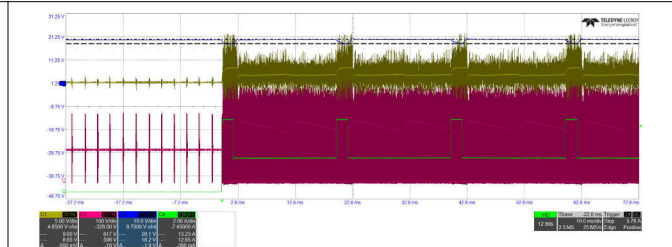

Figure 3-50. VIN=100Vac (2x rated current for 2ms, 0.9x rated current for 18ms)

3.3.14 CCM operation

VSW = PINK, Load Current = GREEN, VOUT = BLUE, FB = YELLOW

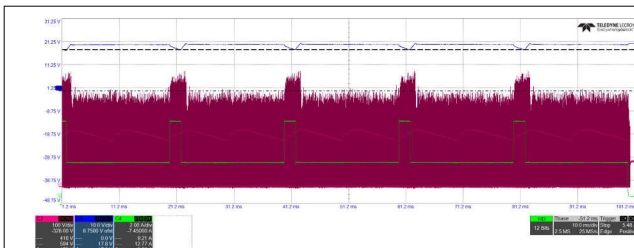

Figure 3-51. VIN=90Vac (2x rated current for 2ms, 0.9x rated current for 18ms)



Figure 3-52. VIN=90Vac (2x rated current for 2ms, 0.9x rated current for 18ms) - Zoomed

3.3.15 EN55022 Class B Conducted EMI Test Result

Please note this was evaluated on an EMI station for pre-qualification purpose only. TI recommends that all final designs be verified by an agency-qualified EMI test house. [Figure 3-54](#) shows scan with existing EVM components. However, [Figure 3-53](#) shows scan taken with the an additional DM choke of 22uH placed before L5 in the schematic. Final EMI analysis will be available in the final release of this EVM.

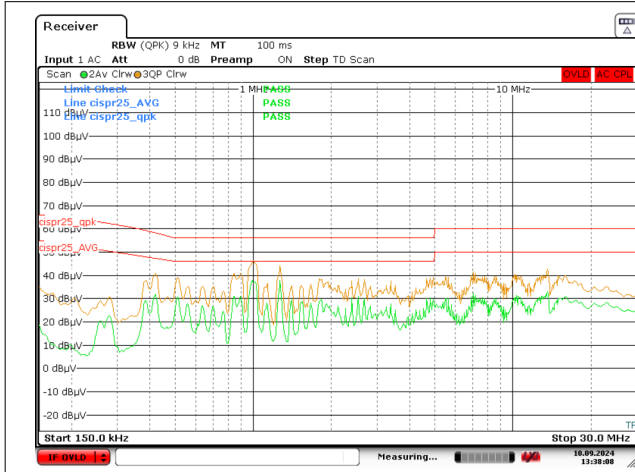

Figure 3-53. VIN = 230V_{RMS}, VOUT = 20V, Load = 3.25A (Output Not Grounded to LISN Ground) - With DM choke modification

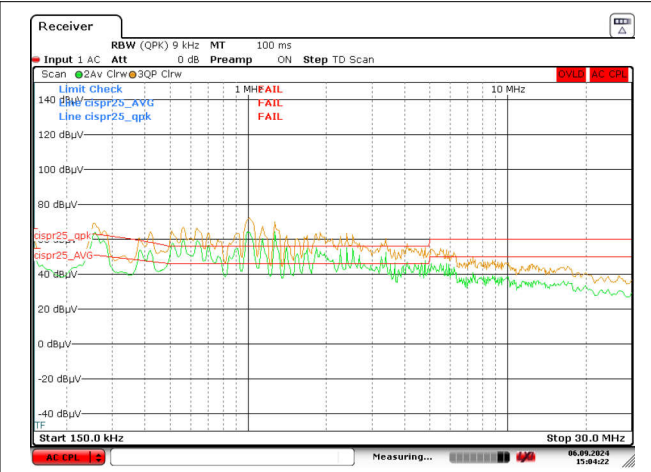

Figure 3-54. VIN = 230V_{RMS}, VOUT = 20V, Load = 3.25A (Output Not Grounded to LISN Ground) - Original EVM

3.3.16 Thermal Images at Full Load (20V and 3.25A)

Figure 3-55 to Figure 3-62 shows the thermal images at full load for different line voltage. The data was taken after a thermal soak of 30 minutes.

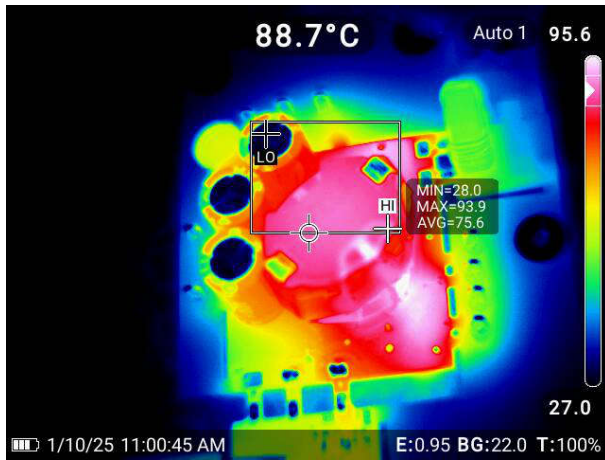

Figure 3-55. $V_{IN} = 90V_{AC}$, Top Side

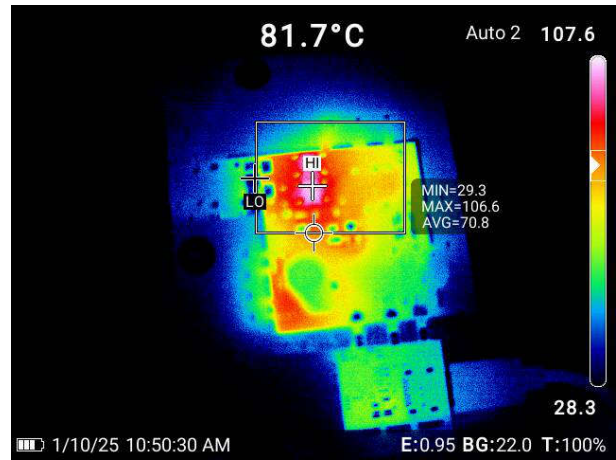

Figure 3-56. $V_{IN} = 90V_{AC}$, Bottom Side

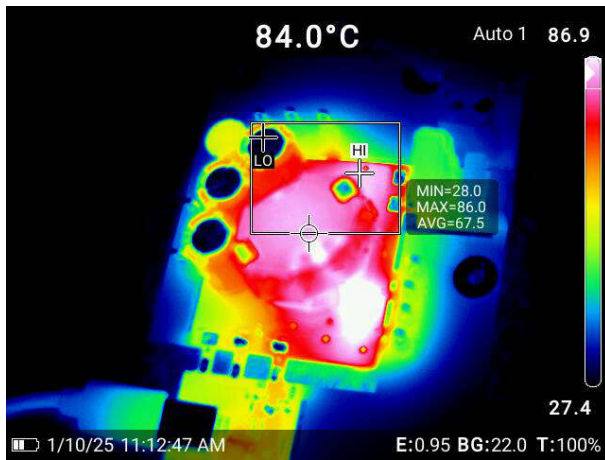

Figure 3-57. $V_{IN} = 115V_{AC}$, Top Side

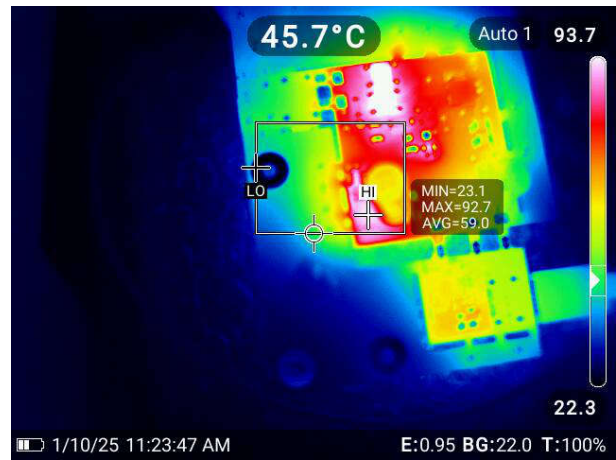

Figure 3-58. $V_{IN} = 115V_{AC}$, Bottom Side

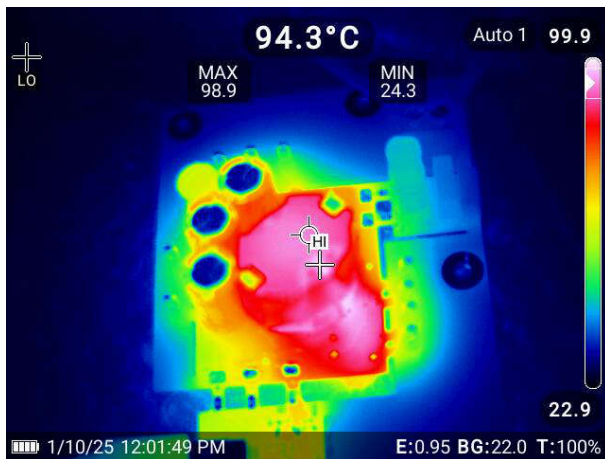

Figure 3-59. $V_{IN} = 230V_{AC}$, Top Side

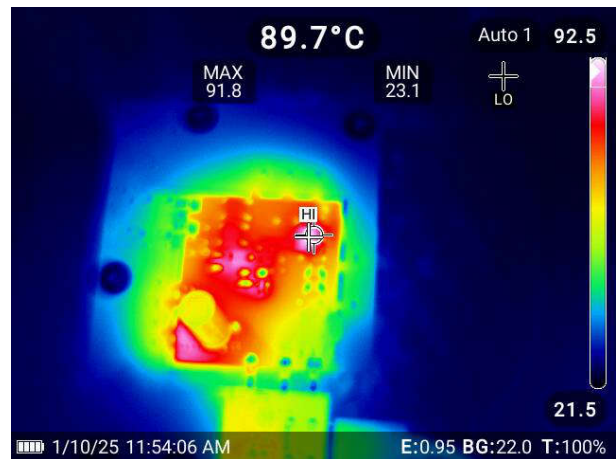

Figure 3-60. $V_{IN} = 230V_{AC}$, Bottom Side

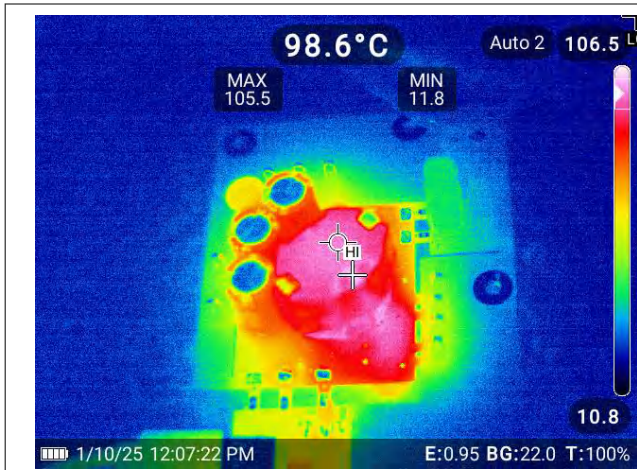

Figure 3-61. $V_{IN} = 265V_{AC}$, Top Side

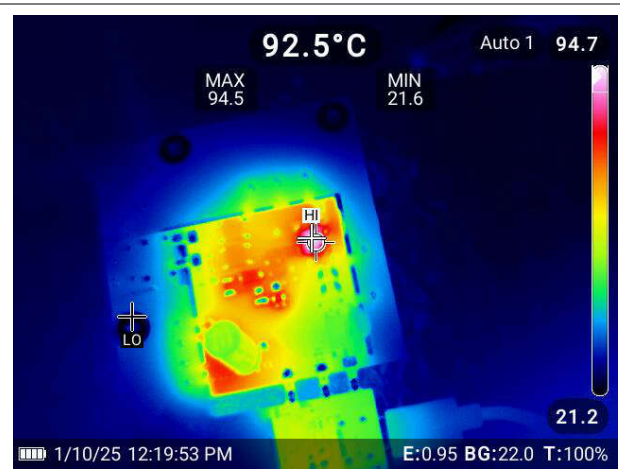
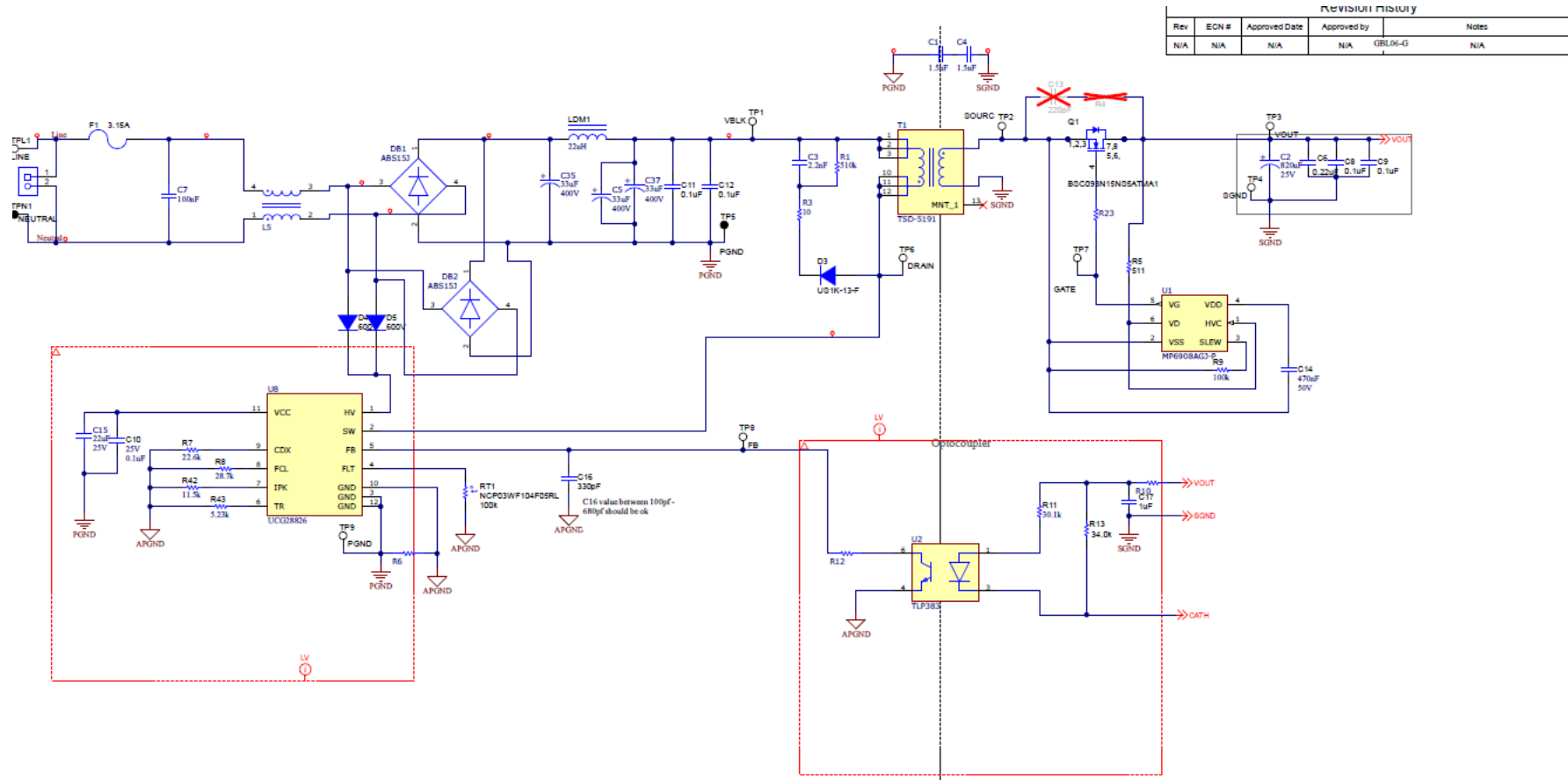

Figure 3-62. $V_{IN} = 265V_{AC}$, Bottom Side

4 Hardware Design Files

4.1 Schematics



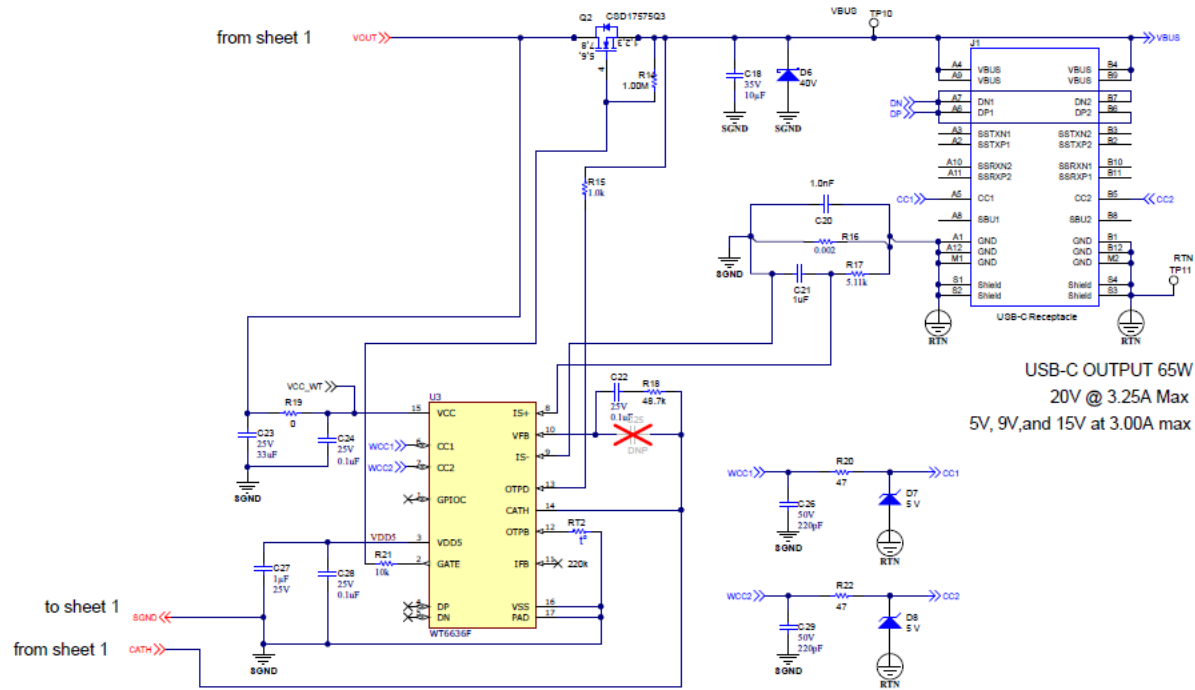

Figure 4-1. UCG28826EVM-093 Schematic Diagram

4.2 PCB Layouts

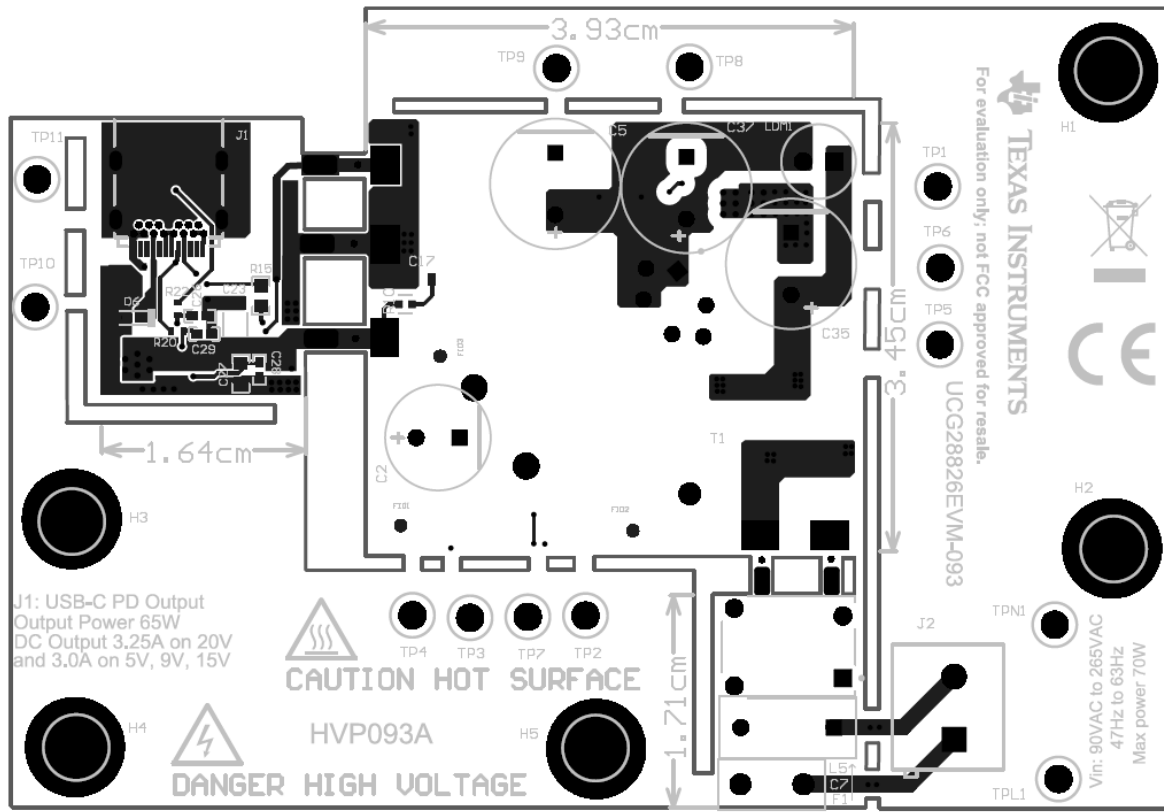

Figure 4-2. EVM Assembly (Top View)

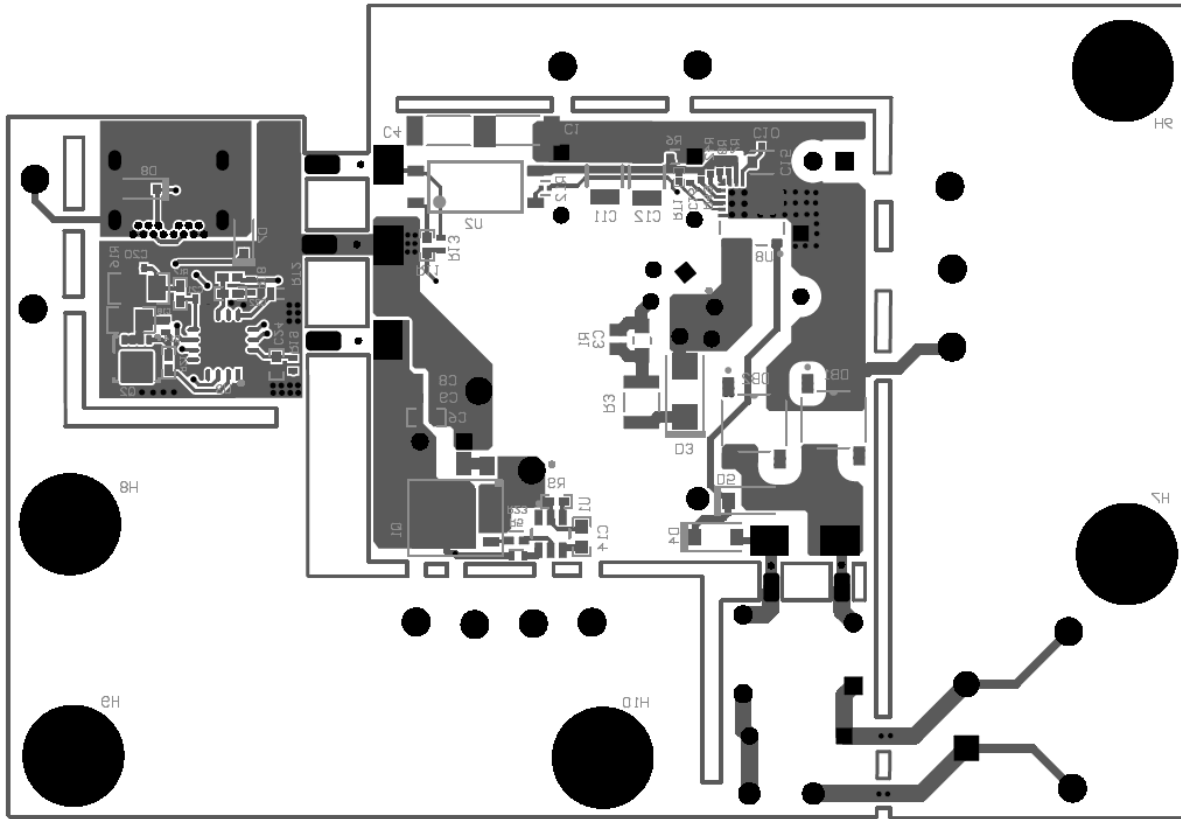

Figure 4-3. EVM Assembly (Bottom View)

4.3 Transformer Details

This design uses three different transformer variants from Renco, Würth Elektronik and Premier Magnetics and the specifications are mentioned below. Also variants are wound on the same RM8 core set and are compatible with EVM.

4.3.1 RLTI-1464 (RENCO)

This transformer is most optimal and recommended for this design to meet the efficiency specifications. This achieves good balance between leakage energy (thereby enabling efficiency) and interwinding capacitance (helps with the thermal performance of UCG28826).

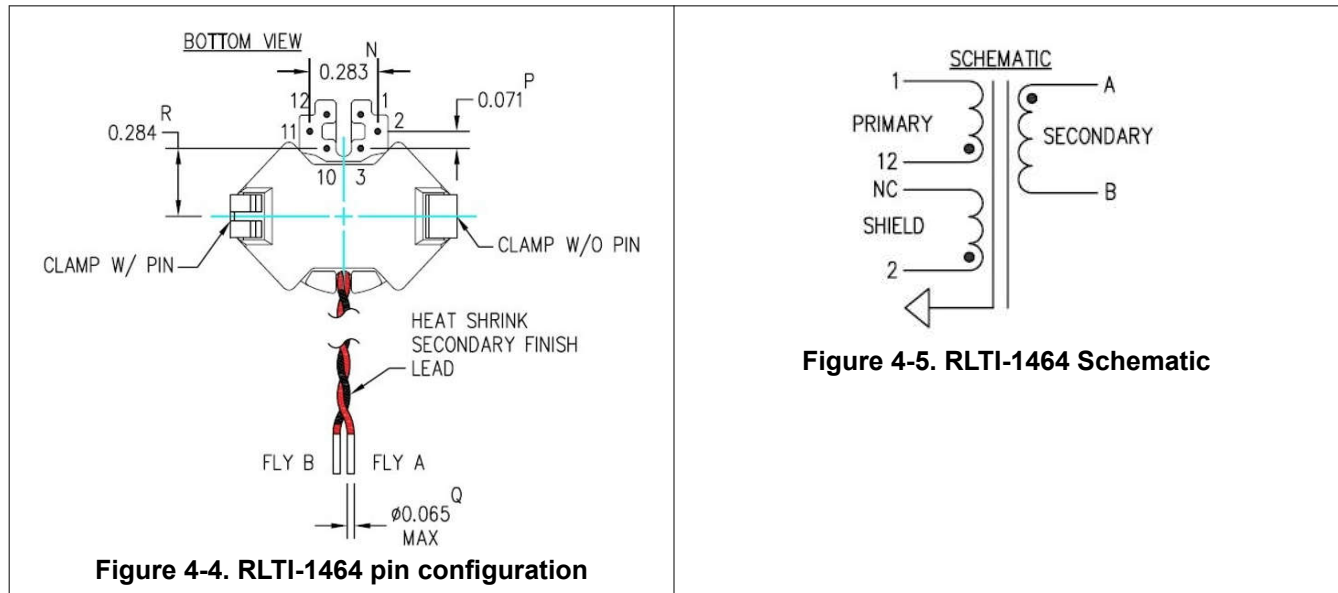

Table 4-1. Transformer Specifications at 25°C

PARAMETER	VALUE	PINS/LEADS	TEST CONDITIONS
Inductance (μH)	200, $\pm 5\%$	1 – 12	Open all other pins, 100kHz / 0.1Vac
Leakage Inductance (μH)	3.5 Max.	1 – 12	Short A - B, 100kHz / 0.1Vac
D.C. resistance (Ω)	0.220, $\pm 15\%$	1 – 12	
D.C. resistance (Ω)	0.007 Max.	A – B	
Dielectric (VAC, 60Hz)	3000Vac	1– A	1mA, 60Hz, 1s
Turns-ratios	6:1	(1-12):(A-B)	APPLY: 1.0V @ 10kHz to (12 - 1) Vout: (A-B) 0.167V

4.3.2 750847341Rev02 (WURTH)

This 750847341Rev02 comes with a turns ratio of 7:1 and hence it is slightly less efficient than RLTI1464. The drawback of 750847341Rev02 is more leakage which slightly lowers efficiency. Interwinding capacitance is similar in performance to RLTI-1464 and also improves the thermal performance of UCG28826. The terminals 3 and 4 of the 750847341Rev02 needs to be shorted externally before these are inserted in to the EVM. There is another optimized variant from Wurth 750847341Rev03 which has a turns ratio of 6:1 with all other specifications remaining the same as the Rev02 variant. If using 750847341Rev02 variant, ensure C3 is 4.7nF capacitor like GRM21AR72H472KW10D, D3 is a slow diode like SL1K and R1 is close to 200k Ω like ERJ-P06J204V. R43 which is the turns ratio setting resistor needs to be changed to 25.5k Ω .

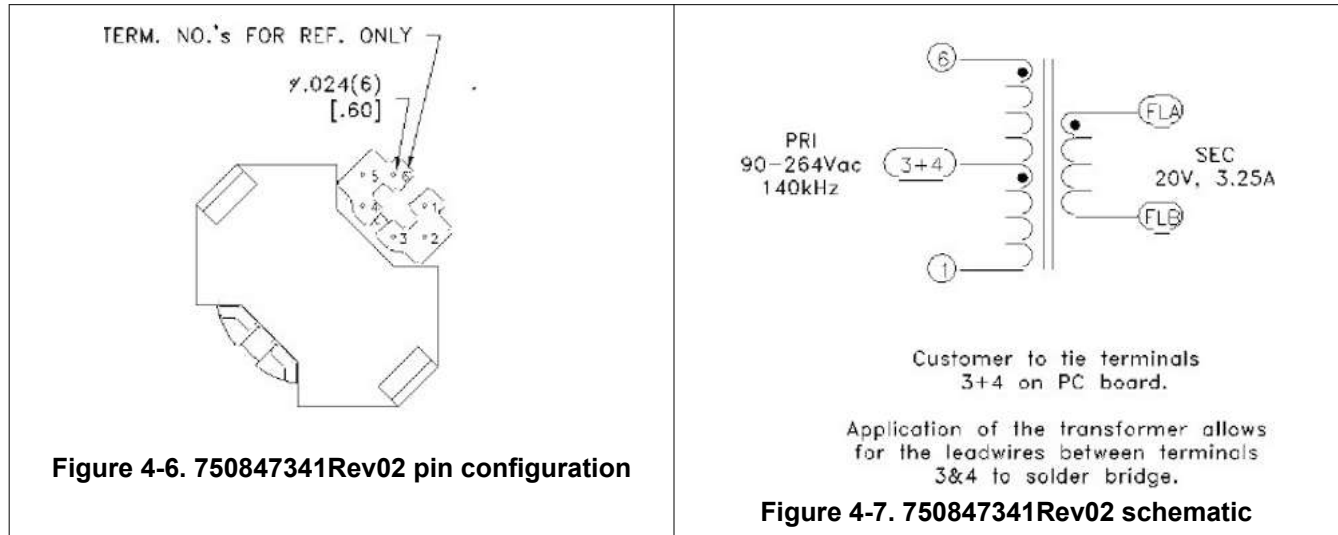

Table 4-2. Transformer Specifications at 25°C

PARAMETER	VALUE	PINS/LEADS	TEST CONDITIONS
Inductance (μH)	200 $\mu\text{H} \pm 10\%$	6:1	Open all other pins, 100kHz / 0.1Vac
Leakage Inductance (μH)	6 μH	6:1	tie(3+4,FLA+FLB),100kHz, 100mV,
D.C. resistance (Ω)	0.23	6:1	tie(3+4), @20°C
D.C. resistance (Ω)	0.03	FLA:FLB	@20°C
Dielectric (VAC, 60Hz)	3000Vac	1- FLA	tie(3+4), 3000VAC, 1 second , 1mA 60Hz
Turns-ratios	7:1	(6-1):(FLA-FLB), tie(3+4)	APPLY: 1.0V @ 10kHz to (6 - 1) Vout: (FLA-FLB) 0.142V

4.3.3 TSD-5191 (Premier Magnetics)

This transformer comes with a turns ratio of 7:1. Although this transformer has the advantage of lowest leakage amongst all variants the major drawback of this transformer is higher interwinding capacitance which heats up the UCG28826 controller. The

Snubber components used can be the same as RLTI-1464. R43 which is the turns ratio setting resistor needs to be changed to 25.5k Ω .

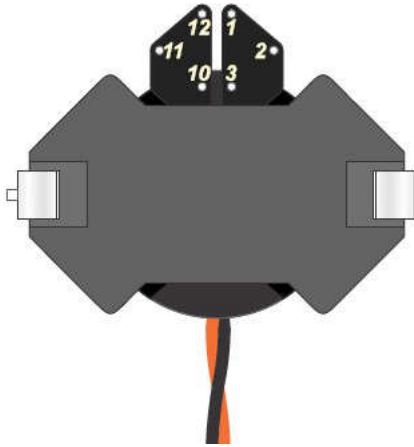

Figure 4-8. TSD-5191 Pin Configuration

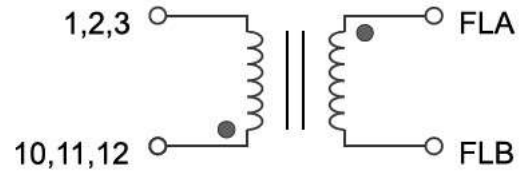

Figure 4-9. TSD-5191 Schematic

Table 4-3. Transformer Specifications at 25°C

PARAMETER	VALUE	PINS/LEADS	TEST CONDITIONS
Inductance (μH)	200 $\mu\text{H} \pm 5\%$	(10,11,12) - (1,2,3)	Open all other pins, 100kHz / 0.1Vac
Leakage Inductance (μH)	3 μH	(10,11,12) - (1,2,3)	Short FLA - FLB, 100kHz / 0.1Vac
Dielectric (VAC, 60Hz)	4000Vac	(10,11,12):FLA	60Hz, 3mA, 1s ramp, 1s dwell
Turns-ratios	7:1	(10,11,12)-(1,2,3): (FLA:FLB)	APPLY: 1.0V @ 10 kHz to (10,11,12)-(1,2,3) Vout: (FLA-FLB) 0.142V

4.3.4 Transformer Summary

Table 4-4. Transformer Specifications Summary

Transformer type	Turns ratio	Leakage	Interwinding Cap
TSD-5191	7:1	1.7uH	240pF
750847341Rev02	7:1	4.9uH	75pF
RLTI-1464	6:1	2.7uH	85pF

Table 4-5. BOM Summary

Transformer type	BOM Modifications
TSD-5191	D3 - US1k-13-F , R3 -10ohms, R2 – 0hms, R1 – 511k, C3 – 1nF, R43 - 25.5k
750847341Rev02	D3 - SL1K/SE20AFJ-M3/6A (trr- 1us); R3 -10ohms, R2 – 0hms, R1 – 150k, C3 – 4.7nF, R43 - 25.5k
RLTI-1464	D3 - US1k-13-F; R3 -10ohms, R2 – 0hms, R1 – 510k, C3 – 2.2nF, R43 - 5.23k

4.4 Bill of Materials

Table 4-6 lists the bill of materials for UCG28826EVM-093.

Table 4-6. Bill of Materials

Designator	Value	Quantity	Description	Part Number	Manufacturer
C1, C4	1.5nF	2	1500 pF ±10% 250VAC Ceramic Capacitor X7R 1808 (4520 Metric)	1808YA250152KJTSYX	Knowles Syfer
C2	820uF	1	820uF 25V ±20% Plugin,D8xL14mm Aluminum Electrolytic Capacitors	NPXD1401E821MF	Ymin
C3	2.2nF	1	2200 pF ±10% 500V Ceramic Capacitor X7R 0805 (2012 Metric)	C0805C222KCRAC7800	KEMET
C5, C35, C37	33uF	3	33uF 400V 500mΩ@100kHz 370mA@100kHz ±20% Plugin,D10xL15mm Aluminum Electrolytic Capacitors	87EC0493	KNSCHA
C6	0.22uF	1	CAP, CERM, 0.22 μF, 50 V, +/- 10%, X7R, AEC-Q200 Grade 1, 0603	CGA3E3X7R1H224K080A B	TDK
C7	100nF	1	Suppression Capacitors P=7.5mm 100nF ±10% X2 310VAC	MPX104K31B3KN20600	KNSCHA
C8, C9	0.1uF	2	CAP, CERM, 0.1 μF, 25 V, +/- 10%, X7R, 0402	GRM155R71E104KE14D	MuRata
C10	0.1uF	1	CAP, CERM, 0.1 uF, 25 V, +/- 10%, X5R, 0201	GRM033R61E104KE14J	MuRata
C11, C12	0.1uF	2	CAP, CERM, 0.1 uF, 630 V, +/- 10%, X7R, 1210	C1210C104KBRAC7800	Kemet
C14	0.47uF	1	CAP, CERM, 0.47 uF, 50 V, +/- 10%, X7R, 0603	C1608X7R1H474K080AC	TDK
C15	22uF	1	22 μF ±20% 25V Ceramic Capacitor X5S 0603 (1608 Metric)	GRM188C61E226ME01J	MuRata
C16	8330pF	1	CAP, CERM, 330 pF, 50 V, +/- 10%, X7R, 0402	GRM155R71H331KA01D	MuRata
C17	1uF	1	CAP, CERM, 1 μF, 25 V, +/- 10%, X7R, 0603	C1608X7R1E105K080AB	TDK
C18	10uF	1	CAP, CERM, 10 μF, 35 V,+/- 10%, X5R, 0805	GMK212BBJ106KG-T	Taiyo Yuden
C20	1000pF	1	CAP, CERM, 1000 pF, 50 V, +/- 10%, X7R, 0402	885012205061	Wurth Elektronik
C21	1uF	1	CAP, CERM, 1 μF, 6.3 V, +/- 20%, X7R, 0402	GRM155R70J105MA12D	MuRata
C22, C24, C28	0.1uF	3	CAP, CERM, 0.1 uF, 25 V, +/- 10%, X7R, 0402	GRM155R71E104KE14D	MuRata
C23	33uF	1	CAP, CERM, 33 uF, 25 V, +/- 20%, X5R, 1206	C3216X5R1E336M160AC	TDK
C26, C29	220pF	1	CAP, CERM, 220 pF, 50 V, +/- 10%, X7R, 0402	GRM155R71H221KA01D	MuRata
C27	1uF	1	CAP, CERM, 1 uF, 25 V, +/- 10%, X7R, AEC-Q200 Grade 1, 0603	GCM188R71E105KA64D	MuRata
D3	800V	1	Diode, Fast Rectifier, 800 V, 1 A, SMA	US1K-13-F	Diodes Inc.

Table 4-6. Bill of Materials (continued)

Designator	Value	Quantity	Description	Part Number	Manufacturer
D4, D5	600V	2	Diode, Switching, 600 V, 1 A, SOD-123	ES1JFL	ON Semiconductor
D6	40V	1	Diode, Schottky, 40 V, 0.2 A, SOD-523	RB521SM-40T2R	Rohm
D7, D8	5V	2	TVS, 5 V, bidirectional, SOD-323	PESD5V0L1BA,115	NXP Semiconductor
DB1, DB2		2	Diode Rectifier Bridge Quad 600V 1.5A 4-Pin ABS T/R	ABS15J	Taiwan Semiconductor
F1	3.15A	1	Fuse, 3.15 A, 250VAC/VDC, TH	RST 3.15-BULK	Bel-Fuse
FID1, FID2, FID3			Fiducial mark. There is nothing to buy or mount.	N/A	N/A
H1, H2, H3, H4, H5		5	MACHINE SCREW PAN PHILLIPS 4-40	NSP-4-4-01	Essentra Components
H6, H7, H8, H9, H10		5	Standoff, Hex, 0.5"L #4-40 Nylon	1902C	Keystone
J1	USB-C Receptacle	1	Connector, Receptacle, USB Type C, R/A	632723300011	Würth Elektronik
J2		1	Terminal Block, 5.08 mm, 2x1, Brass, TH	ED120/2DS	On-Shore Technology
L5		1	2 Line Common Mode Choke Through Hole 2A DCR 50mOhm	DKFP-6248-02D5	Schurter
LDM1	22uH	1	Inductor, Unshielded Drum Core, Ferrite, 22 uH, 1.7 A, 0.102 ohm, TH	7447462220	Würth Elektronik
Q1	150V	1	MOSFET, N-CH, 150 V, 87 A, PG-TDSON-8	BSC093N15NS5ATMA1	Infineon Technologies
Q2	30V	1	MOSFET, N-CH, 30 V, 60 A, DQG0008A (VSON-CLIP-8)	CSD17575Q3	Texas Instruments
R1	510k	1	510 kOhms $\pm 5\%$ 0.5W, 1/2W Chip Resistor 0805 (2012 Metric) Automotive AEC-Q200, Pulse Withstanding Thick Film	ERJ-P06J514V	Panasonic Electronic Components
R3	10	1	10 Ω $\pm 5\%$ 0.5W 1210 Thick Film Chip Resistor AEC-Q200 compliant	RMCF1210JT10R0	Stackpole Electronics
R5	511	1	RES, 511, 1%, 0.063 W, AEC-Q200 Grade 0, 0402	CRCW0402511RFKED	Vishay-Dale
R6, R12	0	2	0 Ω ± 0 0.05W 0201 Thick Film Chip Resistor AEC-Q200 compliant	RMCF0201ZT0R00	Stackpole Electronics
R7	22.6k	1	RES, 22.6 k, 1%, 0.05 W, 0201	RC0201FR-0722K6L	Yageo America
R8	28.7k	1	RES, 28.7 k, 1%, 0.05 W, 0201	CRCW020128K7FKED	Vishay-Dale
R9	100k	1	RES, 100 k, 1%, 0.1 W, 0402	ERJ-2RKF1003X	Panasonic
R10	0	1	RES Thick Film, 0 Ω , 0.2W, 0402	CRCW04020000Z0EDHP	Vishay Dale
R11	30.1k	1	RES, 30.1 k, 1%, 0.063 W, 0402	CRCW040230K1FKED	Vishay-Dale
R13	34k	1	RES, 34.0 k, 1%, 0.063 W, AEC-Q200 Grade 0, 0402	CRCW040234K0FKED	Vishay-Dale
R14	1.0Meg	1	RES, 1.00 M, 1%, 0.063 W, AEC-Q200 Grade 0, 0402	RMCF0402FT1M00	Stackpole Electronics Inc
R15	1k	1	RES, 1.0 k, 5%, 0.25 W, AEC-Q200 Grade 0, 0603	ESR03EZPJ102	Rohm

Table 4-6. Bill of Materials (continued)

Designator	Value	Quantity	Description	Part Number	Manufacturer
R16	0.002	1	RES, 0.002, 1%, 1 W, 1206	CSNL1206FT2L00	Stackpole Electronics Inc
R17	5.11k	1	RES, 5.11 k, 1%, 0.063 W, 0402	CRCW04025K11FKED	Vishay-Dale
R18	4.87k	1	RES, 48.7 k, 1%, 0.063 W, 0402	CRCW040248K7FKED	Vishay-Dale
R19	0	1	RES, 0, 5%, 0.063 W, AEC-Q200 Grade 0, 0402	CRCW04020000Z0ED	Vishay-Dale
R20, R22	47	2	RES, 47, 5%, 0.063 W, 0402	CRCW040247R0JNED	Vishay-Dale
R21	10k	1	RES, 10 k, 5%, 0.063 W, 0402	CRCW040210K0JNED	Vishay-Dale
R23	0 Ω	1	0 Ohms Jumper 0.1W, 1/10W Chip Resistor 0402 (1005 Metric) - Thick Film	CR0402-10W-000T	Venkel
R42	11.5k	1	RES, 11.5 k, 1%, 0.05 W, 0201	RC0201FR-0711K5L	Yageo America
R43	5.23k	1	RES, 5.23 k, 1%, 0.05 W, 0201	RC0201FR-075K23L	Yageo America
RT1	100k	1	Thermistor NTC, 100k ohm, 1%, 0201	NCP03WF104F05RL	MuRata
RT2	220k	1	Thermistor NTC, 220k ohm, 5%, 0603	NCP18WM224J03RB	MuRata
T1		1	Flyback Transformer	TSD-5191 RLTI-1464/1454 750847341	Premier Magnetics RENCO Wurth Elektronik
TP1		1	Test Point, Multipurpose, White, TH	5012	Keystone
TP2		1	Test Point, Multipurpose, White, TH	5012	Keystone
TP3		1	Test Point, Multipurpose, White, TH	5012	Keystone
TP4		1	Test Point, Multipurpose, White, TH	5012	Keystone
TP5		1	Test Point, Multipurpose, Black, TH	5011	Keystone
TP6		1	Test Point, Multipurpose, White, TH	5012	Keystone
TP7		1	Test Point, Multipurpose, White, TH	5012	Keystone
TP8		1	Test Point, Multipurpose, White, TH	5012	Keystone
TP9		1	Test Point, Multipurpose, White, TH	5012	Keystone
TP10		1	Test Point, Multipurpose, White, TH	5012	Keystone
TP11		1	Test Point, Multipurpose, White, TH	5012	Keystone
TPL1		1	Test Point, Multipurpose, White, TH	5012	Keystone
TPN1		1	Test Point, Multipurpose, Black, TH	5011	Keystone
U1		1	FAST TURN-OFF INTELLIGENT RECTIFIER	MP6908AGJ-P	Monolithic Power Systems
U2		1	Optoisolator Transistor Output 5000Vrms 1 Channel 6-SO	TLP383(GR-TPL,E	Toshiba
U3		1	USB PD/QC4/QC4+ Controller	WT6636F	Weltrend
U8		1	UCG28826 - Flyback controller	UCG28826	Texas Instruments

5 Appendix - Efficiency

In this section, the input current into the EVM was measured using a precision ammeter in order to remove the uncertainties with the current measurement offset in the power analyzer which can arise due to improper calibration of the equipment.

SYSTEMS CHARACTERISTICS				
η	Full-load efficiency ($V_{IN}=115/230V_{RMS}$)	$V_{OUT} = 20V, I_{OUT} = 3.25A$	94.08 / 94.63	%
		$V_{OUT} = 15V, I_{OUT} = 3.00A$	93.88 / 94.31	
		$V_{OUT} = 9V, I_{OUT} = 3.00A$	93.66 / 93	
		$V_{OUT} = 5V, I_{OUT} = 3.00A$	92.8 / 91.67	
η	4-point average efficiency ⁽¹⁾ $V_{IN}=115/230V_{RMS}$	$V_{OUT} = 20V$ (CoC Tier 2, 89.0%)	94.14 / 93.85	%
		$V_{OUT} = 15V$ (CoC Tier 2, 88.9%)	94.15 / 92.95	
		$V_{OUT} = 9V$ (CoC Tier 2, 87.3%)	93.6 / 91.64	
		$V_{OUT} = 5V$ (CoC Tier 2, 81.8%)	92.28 / 89.23	
η	Efficiency at 10% Load $V_{IN}=115/230V_{RMS}$	$V_{OUT} = 20V$ (CoC Tier 2, 79.0%)	92.04 / 89.39	%
		$V_{OUT} = 15V$ (CoC Tier 2, 78.9%)	92.4 / 89.71	
		$V_{OUT} = 9V$ (CoC Tier 2, 77.3%)	92.6 / 89.29	
		$V_{OUT} = 5V$ (CoC Tier 2, 72.5%)	90.6 / 86.64	

5.1 Efficiency Result of 4-Point Average on 20V_{OUT}

V _{IN} (VRMS)	P _{IN} (W)	I _{IN} (IRMS)	PF	P _{OUT} (W)	P _{EMULATOR} (W)	P _{out} %	EFFICIENCY	4-PT AVERAGE EFFICIENCY
89.88	70.8	1.665	0.473	65.64	0.204	100%	93.1%	94.04%
89.91	52.64	1.333	0.439	49.214	0.2	75%	93.87%	
89.94	34.82	0.914	0.424	32.777	0.2	50%	94.7%	
89.98	17.62	0.574	0.341	16.46	0.2	25%	94.57%	
90.03	7.36	0.221	0.37	6.6193	0.2	10%	92.68%	
114.91	69.73	1.38	0.44	65.65	0.203	100%	94.45%	94.86%
114.94	52.05	1.226	0.369	449.235	0.203	75%	94.97%	
114.96	34.65	0.815	0.37	32.778	0.2	50%	95.18%	
115	17.58	0.421	0.363	16.474	0.2	25%	94.82%	
115.04	7.39	0.176	0.365	6.62	0.199	10%	92.28%	
229.98	69.01	0.886	0.339	65.662	0.2	100%	95.43%	94.51%
230.01	51.90	0.674	0.335	49.235	0.2	75%	95.24%	
230.01	34.84	0.46	0.329	32.778	0.2	50%	94.65%	
230.02	17.98	0.236	0.331	16.471	0.2	25%	92.7%	
230.08	7.62	0.109	0.304	6.6214	0.199	10%	89.52%	
264	69.11	0.781	0.335	65.684	0.2	100%	95.33%	93.86%
264	52.1	0.596	0.331	49.235	0.2	75%	94.89%	
264	35.06	0.411	0.323	32.678	0.2	50%	94.04%	
264.02	18.29	0.215	0.322	16.475	0.2	25%	91.17%	
264.1	7.62	0.096	0.3	6.62	0.199	10%	89.54%	
CoC Tier 2, 4-pt average								89.0%
CoC Tier 2, 10%-load								79.0%

5.2 Efficiency Result of 4-Point Average on 15V_{OUT}

V _{IN} (VRMS)	P _{IN} (W)	I _{IN} (IRMS)	PF	P _{OUT} (W)	P _{EMULATOR} (W)	P _{out} %	EFFICIENCY	4-PT AVERAGE EFFICIENCY
89.92	48.79	1.252	0.433	45.525	0.15	100%	93.61%	94.25%
89.95	36.35	0.95	0.425	34.088	0.148	75%	94.18%	
89.97	24.17	0.691	0.389	22.735	0.148	50%	94.67%	
89.99	12.2	0.397	0.342	11.384	0.15	25%	94.54%	
90.03	5.08	0.157	0.36	4.5789	0.148	10%	92.99%	
114.94	48.24	1.161	0.362	45.525	0.148	100%	94.68%	94.69%
114.95	36.1	0.85	0.37	34.105	0.15	75%	94.88%	
114.98	24.07	0.569	0.368	22.737	0.15	50%	95.09%	
115	12.25	0.281	0.379	11.382	0.15	25%	94.11%	
115.04	5.08	0.122	0.362	4.5776	0.149	10%	93.02%	
230	48.1	0.626	0.334	45.527	0.148	100%	94.95%	93.63%
230	36.19	0.477	0.33	34.088	0.148	75%	94.59%	
230	24.39	0.33	0.321	22.742	0.148	50%	93.86%	
230.02	12.65	0.172	0.32	11.382	0.148	25%	91.13%	
230.09	5.19	0.075	0.298	4.5757	0.15	10%	91.1%	
264	48.26	0.554	0.33	45.52	0.15	100%	94.62%	92.71%
264	36.43	0.426	0.324	34.101	0.148	75%	94.02%	
264.02	24.64	0.297	0.314	22.735	0.148	50%	92.88%	
264.04	12.91	0.157	0.311	11.383	0.148	25%	89.33%	
264.08	5.3	0.07	0.287	4.5779	0.148	10%	89.14%	
CoC Tier 2, 4-pt average								88.9%
CoC Tier 2, 10%-load								78.

5.3 Efficiency Result of 4-Point Average on 9V_{OUT}

V _{IN} (VRMS)	P _{IN} (W)	I _{IN} (IRMS)	PF	P _{OUT} (W)	P _{EMULATOR} (W)	P _{out} %	EFFICIENCY	4-PT AVERAGE EFFICIENCY
89.96	29.21	0.784	0.414	27.316	0.087	100%	93.8%	93.87%
89.98	21.86	0.635	0.383	20.424	0.087	75%	93.85%	
89.99	14.56	0.475	0.341	13.607	0.087	50%	94.06%	
90.0	7.35	0.222	0.368	6.8052	0.088	25%	93.78%	
90.03	3.04	0.095	0.356	2.7394	0.087	10%	92.93%	
114.98	29.08	0.683	0.37	27.307	0.087	100%	94.2%	94.12%
114.99	21.72	0.514	0.368	20.432	0.088	75%	94.47%	
115.0	14.53	0.35	0.361	13.601	0.087	50%	94.23%	
115.01	7.37	0.176	0.364	6.8077	0.088	25%	93.57%	
115.03	3.03	0.077	0.342	2.7368	0.088	10%	93.32%	
230.06	29.33	0.391	0.326	27.319	0.087	100%	93.43%	92.12%
230.06	22.04	0.3	0.319	20.42	0.089	75%	93.03%	
230.06	14.93	0.199	0.326	13.604	0.088	50%	91.71%	
230.06	7.63	0.109	0.304	6.8056	0.088	25%	90.32%	
230.08	3.14	0.049	0.279	2.739	0.087	10%	90.01%	
264.07	29.52	0.35	0.319	27.309	0.087	100%	92.8%	91.01%
264.07	22.25	0.27	0.312	20.42	0.087	75%	92.16%	
264.05	15.13	0.181	0.317	13.606	0.087	50%	90.49%	
264.05	7.78	0.098	0.301	6.803	0.087	25%	88.59%	
264.07	3.18	0.045	0.267	2.739	0.087	10%	88.9%	
CoC Tier 2, 4-pt average								87.3%
CoC Tier 2, 10%-load								77.3%

5.4 Efficiency Result of 4-Point Average on 5V_{OUT}

V _{IN} (VRMS)	P _{IN} (W)	I _{IN} (IRMS)	PF	P _{OUT} (W)	P _{EMULATOR} (W)	P _{out} %	EFFICIENCY	4-PT AVERAGE EFFICIENCY
89.99	16.52	0.542	0.339	15.242	0.048	100%	92.55%	92.79%
90	12.27	0.399	0.342	11.382	0.049	75%	93.13%	
90	8.21	0.246	0.371	7.5643	0.049	50%	92.76%	
90.02	4.13	0.13	0.353	3.7775	0.049	25%	92.72%	
90.03	1.71	0.057	0.334	1.5192	0.049	10%	91.57%	
115	16.48	0.395	0.363	15.243	0.048	100%	92.81%	92.71%
115	12.32	0.282	0.38	11.395	0.048	75%	92.9%	
115.01	8.2	0.194	0.368	7.5648	0.048	50%	92.79%	
115.01	4.14	0.102	0.353	3.7773	0.048	25%	92.32%	
115.03	1.74	0.047	0.322	1.5204	0.048	10%	90.23%	
230.04	16.68	0.22	0.33	15.242	0.049	100%	91.67%	89.64%
230.05	12.67	0.172	0.32	11.395	0.049	75%	90.32%	
230.06	8.59	0.121	0.308	7.5737	0.048	50%	88.78%	
230.06	4.36	0.065	0.292	3.7791	0.048	25%	87.79%	
230.08	1.805	0.031	0.256	1.5205	0.049	10%	86.99%	
264.04	16.91	0.2	0.32	15.258	0.048	100%	90.52%	88.45%
264.05	12.82	0.156	0.311	11.397	0.049	75%	89.26%	
264.07	8.75	0.111	0.299	7.5673	0.048	50%	87.04%	
264.07	4.4	0.059	0.281	3.777	0.048	25%	87%	
264.09	1.83	0.028	0.243	1.5192	0.048	10%	85.86%	
CoC Tier 2, 4-pt average								81.8%
CoC Tier 2, 10%-load								72.5%

5.5 Efficiency Typical Results

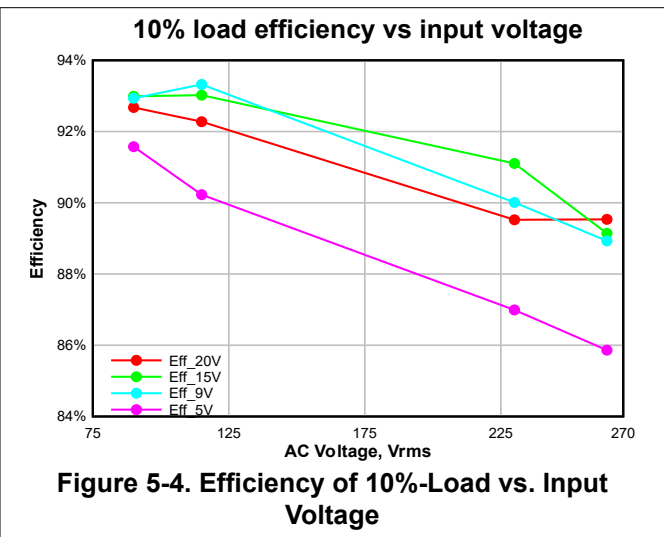
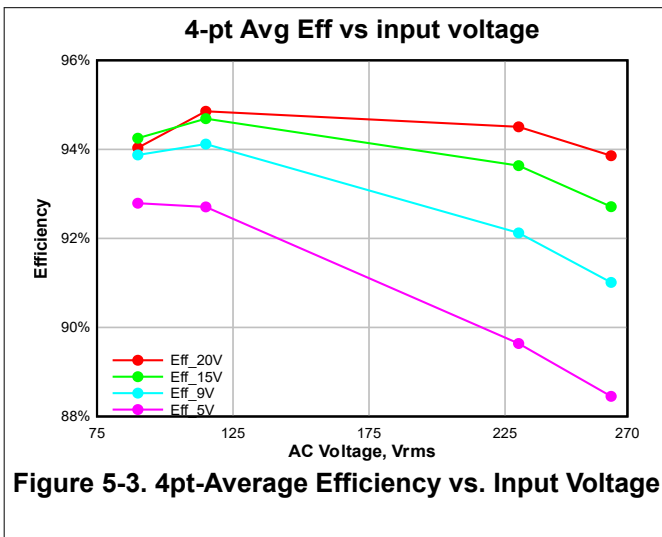
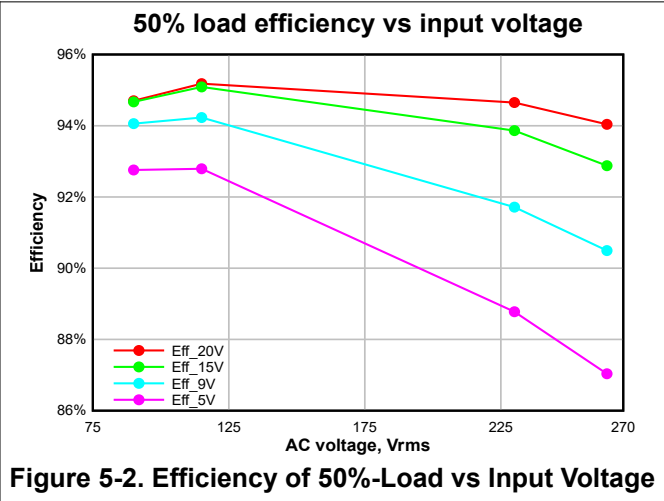
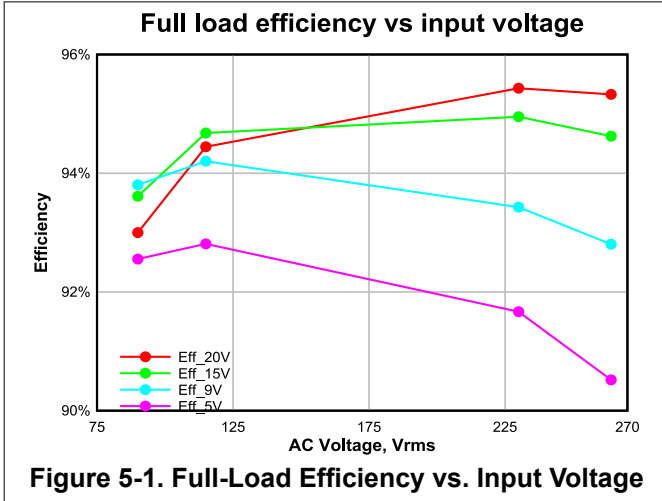

6 Additional Information

Trademarks

All trademarks are the property of their respective owners.

7 Revision History

NOTE: Page numbers for previous revisions may differ from page numbers in the current version.

Changes from Revision * (October 2024) to Revision A (February 2025)	Page
• Updated images in the <i>Thermal Images at Full Load (20V and 3.25A)</i> section.....	25

STANDARD TERMS FOR EVALUATION MODULES

1. *Delivery:* TI delivers TI evaluation boards, kits, or modules, including any accompanying demonstration software, components, and/or documentation which may be provided together or separately (collectively, an "EVM" or "EVMs") to the User ("User") in accordance with the terms set forth herein. User's acceptance of the EVM is expressly subject to the following terms.
 - 1.1 EVMs are intended solely for product or software developers for use in a research and development setting to facilitate feasibility evaluation, experimentation, or scientific analysis of TI semiconductor products. EVMs have no direct function and are not finished products. EVMs shall not be directly or indirectly assembled as a part or subassembly in any finished product. For clarification, any software or software tools provided with the EVM ("Software") shall not be subject to the terms and conditions set forth herein but rather shall be subject to the applicable terms that accompany such Software
 - 1.2 EVMs are not intended for consumer or household use. EVMs may not be sold, sublicensed, leased, rented, loaned, assigned, or otherwise distributed for commercial purposes by Users, in whole or in part, or used in any finished product or production system.
2. *Limited Warranty and Related Remedies/Disclaimers:*
 - 2.1 These terms do not apply to Software. The warranty, if any, for Software is covered in the applicable Software License Agreement.
 - 2.2 TI warrants that the TI EVM will conform to TI's published specifications for ninety (90) days after the date TI delivers such EVM to User. Notwithstanding the foregoing, TI shall not be liable for a nonconforming EVM if (a) the nonconformity was caused by neglect, misuse or mistreatment by an entity other than TI, including improper installation or testing, or for any EVMs that have been altered or modified in any way by an entity other than TI, (b) the nonconformity resulted from User's design, specifications or instructions for such EVMs or improper system design, or (c) User has not paid on time. Testing and other quality control techniques are used to the extent TI deems necessary. TI does not test all parameters of each EVM. User's claims against TI under this Section 2 are void if User fails to notify TI of any apparent defects in the EVMs within ten (10) business days after delivery, or of any hidden defects with ten (10) business days after the defect has been detected.
 - 2.3 TI's sole liability shall be at its option to repair or replace EVMs that fail to conform to the warranty set forth above, or credit User's account for such EVM. TI's liability under this warranty shall be limited to EVMs that are returned during the warranty period to the address designated by TI and that are determined by TI not to conform to such warranty. If TI elects to repair or replace such EVM, TI shall have a reasonable time to repair such EVM or provide replacements. Repaired EVMs shall be warranted for the remainder of the original warranty period. Replaced EVMs shall be warranted for a new full ninety (90) day warranty period.

WARNING

Evaluation Kits are intended solely for use by technically qualified, professional electronics experts who are familiar with the dangers and application risks associated with handling electrical mechanical components, systems, and subsystems.

User shall operate the Evaluation Kit within TI's recommended guidelines and any applicable legal or environmental requirements as well as reasonable and customary safeguards. Failure to set up and/or operate the Evaluation Kit within TI's recommended guidelines may result in personal injury or death or property damage. Proper set up entails following TI's instructions for electrical ratings of interface circuits such as input, output and electrical loads.

NOTE:

EXPOSURE TO ELECTROSTATIC DISCHARGE (ESD) MAY CAUSE DEGRADATION OR FAILURE OF THE EVALUATION KIT; TI RECOMMENDS STORAGE OF THE EVALUATION KIT IN A PROTECTIVE ESD BAG.

3 Regulatory Notices:

3.1 United States

3.1.1 Notice applicable to EVMs not FCC-Approved:

FCC NOTICE: This kit is designed to allow product developers to evaluate electronic components, circuitry, or software associated with the kit to determine whether to incorporate such items in a finished product and software developers to write software applications for use with the end product. This kit is not a finished product and when assembled may not be resold or otherwise marketed unless all required FCC equipment authorizations are first obtained. Operation is subject to the condition that this product not cause harmful interference to licensed radio stations and that this product accept harmful interference. Unless the assembled kit is designed to operate under part 15, part 18 or part 95 of this chapter, the operator of the kit must operate under the authority of an FCC license holder or must secure an experimental authorization under part 5 of this chapter.

3.1.2 For EVMs annotated as FCC – FEDERAL COMMUNICATIONS COMMISSION Part 15 Compliant:

CAUTION

This device complies with part 15 of the FCC Rules. Operation is subject to the following two conditions: (1) This device may not cause harmful interference, and (2) this device must accept any interference received, including interference that may cause undesired operation.

Changes or modifications not expressly approved by the party responsible for compliance could void the user's authority to operate the equipment.

FCC Interference Statement for Class A EVM devices

NOTE: This equipment has been tested and found to comply with the limits for a Class A digital device, pursuant to part 15 of the FCC Rules. These limits are designed to provide reasonable protection against harmful interference when the equipment is operated in a commercial environment. This equipment generates, uses, and can radiate radio frequency energy and, if not installed and used in accordance with the instruction manual, may cause harmful interference to radio communications. Operation of this equipment in a residential area is likely to cause harmful interference in which case the user will be required to correct the interference at his own expense.

FCC Interference Statement for Class B EVM devices

NOTE: This equipment has been tested and found to comply with the limits for a Class B digital device, pursuant to part 15 of the FCC Rules. These limits are designed to provide reasonable protection against harmful interference in a residential installation. This equipment generates, uses and can radiate radio frequency energy and, if not installed and used in accordance with the instructions, may cause harmful interference to radio communications. However, there is no guarantee that interference will not occur in a particular installation. If this equipment does cause harmful interference to radio or television reception, which can be determined by turning the equipment off and on, the user is encouraged to try to correct the interference by one or more of the following measures:

- Reorient or relocate the receiving antenna.
- Increase the separation between the equipment and receiver.
- Connect the equipment into an outlet on a circuit different from that to which the receiver is connected.
- Consult the dealer or an experienced radio/TV technician for help.

3.2 Canada

3.2.1 For EVMs issued with an Industry Canada Certificate of Conformance to RSS-210 or RSS-247

Concerning EVMs Including Radio Transmitters:

This device complies with Industry Canada license-exempt RSSs. Operation is subject to the following two conditions:

(1) this device may not cause interference, and (2) this device must accept any interference, including interference that may cause undesired operation of the device.

Concernant les EVMs avec appareils radio:

Le présent appareil est conforme aux CNR d'Industrie Canada applicables aux appareils radio exempts de licence. L'exploitation est autorisée aux deux conditions suivantes: (1) l'appareil ne doit pas produire de brouillage, et (2) l'utilisateur de l'appareil doit accepter tout brouillage radioélectrique subi, même si le brouillage est susceptible d'en compromettre le fonctionnement.

Concerning EVMs Including Detachable Antennas:

Under Industry Canada regulations, this radio transmitter may only operate using an antenna of a type and maximum (or lesser) gain approved for the transmitter by Industry Canada. To reduce potential radio interference to other users, the antenna type and its gain should be so chosen that the equivalent isotropically radiated power (e.i.r.p.) is not more than that necessary for successful communication. This radio transmitter has been approved by Industry Canada to operate with the antenna types listed in the user guide with the maximum permissible gain and required antenna impedance for each antenna type indicated. Antenna types not included in this list, having a gain greater than the maximum gain indicated for that type, are strictly prohibited for use with this device.

Concernant les EVMs avec antennes détachables

Conformément à la réglementation d'Industrie Canada, le présent émetteur radio peut fonctionner avec une antenne d'un type et d'un gain maximal (ou inférieur) approuvé pour l'émetteur par Industrie Canada. Dans le but de réduire les risques de brouillage radioélectrique à l'intention des autres utilisateurs, il faut choisir le type d'antenne et son gain de sorte que la puissance isotrope rayonnée équivalente (p.i.r.e.) ne dépasse pas l'intensité nécessaire à l'établissement d'une communication satisfaisante. Le présent émetteur radio a été approuvé par Industrie Canada pour fonctionner avec les types d'antenne énumérés dans le manuel d'usage et ayant un gain admissible maximal et l'impédance requise pour chaque type d'antenne. Les types d'antenne non inclus dans cette liste, ou dont le gain est supérieur au gain maximal indiqué, sont strictement interdits pour l'exploitation de l'émetteur.

3.3 Japan

3.3.1 *Notice for EVMs delivered in Japan:* Please see http://www.tij.co.jp/lstds/ti_ja/general/eStore/notice_01.page 日本国内に輸入される評価用キット、ボードについては、次のところをご覧ください。

<https://www.ti.com/ja-jp/legal/notice-for-evaluation-kits-delivered-in-japan.html>

3.3.2 *Notice for Users of EVMs Considered "Radio Frequency Products" in Japan:* EVMs entering Japan may not be certified by TI as conforming to Technical Regulations of Radio Law of Japan.

If User uses EVMs in Japan, not certified to Technical Regulations of Radio Law of Japan, User is required to follow the instructions set forth by Radio Law of Japan, which includes, but is not limited to, the instructions below with respect to EVMs (which for the avoidance of doubt are stated strictly for convenience and should be verified by User):

1. Use EVMs in a shielded room or any other test facility as defined in the notification #173 issued by Ministry of Internal Affairs and Communications on March 28, 2006, based on Sub-section 1.1 of Article 6 of the Ministry's Rule for Enforcement of Radio Law of Japan,
2. Use EVMs only after User obtains the license of Test Radio Station as provided in Radio Law of Japan with respect to EVMs, or
3. Use of EVMs only after User obtains the Technical Regulations Conformity Certification as provided in Radio Law of Japan with respect to EVMs. Also, do not transfer EVMs, unless User gives the same notice above to the transferee. Please note that if User does not follow the instructions above, User will be subject to penalties of Radio Law of Japan.

【無線電波を送信する製品の開発キットをお使いになる際の注意事項】 開発キットの中には技術基準適合証明を受けていないものがあります。技術適合証明を受けていないものご使用に際しては、電波法遵守のため、以下のいずれかの措置を取っていただく必要がありますのでご注意ください。

1. 電波法施行規則第6条第1項第1号に基づく平成18年3月28日総務省告示第173号で定められた電波暗室等の試験設備でご使用いただく。
2. 実験局の免許を取得後ご使用いただく。
3. 技術基準適合証明を取得後ご使用いただく。

なお、本製品は、上記の「ご使用にあたっての注意」を譲渡先、移転先に通知しない限り、譲渡、移転できないものとします。

上記を遵守頂けない場合は、電波法の罰則が適用される可能性があることをご留意ください。日本テキサス・イ

ンスツルメンツ株式会社

東京都新宿区西新宿 6 丁目 2 4 番 1 号

西新宿三井ビル

3.3.3 *Notice for EVMs for Power Line Communication:* Please see http://www.tij.co.jp/lstds/ti_ja/general/eStore/notice_02.page

電力線搬送波通信についての開発キットをお使いになる際の注意事項については、次のところをご覧ください。 <https://www.ti.com/ja-jp/legal/notice-for-evaluation-kits-for-power-line-communication.html>

3.4 European Union

3.4.1 *For EVMs subject to EU Directive 2014/30/EU (Electromagnetic Compatibility Directive):*

This is a class A product intended for use in environments other than domestic environments that are connected to a low-voltage power-supply network that supplies buildings used for domestic purposes. In a domestic environment this product may cause radio interference in which case the user may be required to take adequate measures.

-
4. *EVM Use Restrictions and Warnings:*
 - 4.1 EVMS ARE NOT FOR USE IN FUNCTIONAL SAFETY AND/OR SAFETY CRITICAL EVALUATIONS, INCLUDING BUT NOT LIMITED TO EVALUATIONS OF LIFE SUPPORT APPLICATIONS.
 - 4.2 User must read and apply the user guide and other available documentation provided by TI regarding the EVM prior to handling or using the EVM, including without limitation any warning or restriction notices. The notices contain important safety information related to, for example, temperatures and voltages.
 - 4.3 *Safety-Related Warnings and Restrictions:*
 - 4.3.1 User shall operate the EVM within TI's recommended specifications and environmental considerations stated in the user guide, other available documentation provided by TI, and any other applicable requirements and employ reasonable and customary safeguards. Exceeding the specified performance ratings and specifications (including but not limited to input and output voltage, current, power, and environmental ranges) for the EVM may cause personal injury or death, or property damage. If there are questions concerning performance ratings and specifications, User should contact a TI field representative prior to connecting interface electronics including input power and intended loads. Any loads applied outside of the specified output range may also result in unintended and/or inaccurate operation and/or possible permanent damage to the EVM and/or interface electronics. Please consult the EVM user guide prior to connecting any load to the EVM output. If there is uncertainty as to the load specification, please contact a TI field representative. During normal operation, even with the inputs and outputs kept within the specified allowable ranges, some circuit components may have elevated case temperatures. These components include but are not limited to linear regulators, switching transistors, pass transistors, current sense resistors, and heat sinks, which can be identified using the information in the associated documentation. When working with the EVM, please be aware that the EVM may become very warm.
 - 4.3.2 EVMs are intended solely for use by technically qualified, professional electronics experts who are familiar with the dangers and application risks associated with handling electrical mechanical components, systems, and subsystems. User assumes all responsibility and liability for proper and safe handling and use of the EVM by User or its employees, affiliates, contractors or designees. User assumes all responsibility and liability to ensure that any interfaces (electronic and/or mechanical) between the EVM and any human body are designed with suitable isolation and means to safely limit accessible leakage currents to minimize the risk of electrical shock hazard. User assumes all responsibility and liability for any improper or unsafe handling or use of the EVM by User or its employees, affiliates, contractors or designees.
 - 4.4 User assumes all responsibility and liability to determine whether the EVM is subject to any applicable international, federal, state, or local laws and regulations related to User's handling and use of the EVM and, if applicable, User assumes all responsibility and liability for compliance in all respects with such laws and regulations. User assumes all responsibility and liability for proper disposal and recycling of the EVM consistent with all applicable international, federal, state, and local requirements.
 5. *Accuracy of Information:* To the extent TI provides information on the availability and function of EVMs, TI attempts to be as accurate as possible. However, TI does not warrant the accuracy of EVM descriptions, EVM availability or other information on its websites as accurate, complete, reliable, current, or error-free.
 6. *Disclaimers:*
 - 6.1 EXCEPT AS SET FORTH ABOVE, EVMS AND ANY MATERIALS PROVIDED WITH THE EVM (INCLUDING, BUT NOT LIMITED TO, REFERENCE DESIGNS AND THE DESIGN OF THE EVM ITSELF) ARE PROVIDED "AS IS" AND "WITH ALL FAULTS." TI DISCLAIMS ALL OTHER WARRANTIES, EXPRESS OR IMPLIED, REGARDING SUCH ITEMS, INCLUDING BUT NOT LIMITED TO ANY EPIDEMIC FAILURE WARRANTY OR IMPLIED WARRANTIES OF MERCHANTABILITY OR FITNESS FOR A PARTICULAR PURPOSE OR NON-INFRINGEMENT OF ANY THIRD PARTY PATENTS, COPYRIGHTS, TRADE SECRETS OR OTHER INTELLECTUAL PROPERTY RIGHTS.
 - 6.2 EXCEPT FOR THE LIMITED RIGHT TO USE THE EVM SET FORTH HEREIN, NOTHING IN THESE TERMS SHALL BE CONSTRUED AS GRANTING OR CONFERRING ANY RIGHTS BY LICENSE, PATENT, OR ANY OTHER INDUSTRIAL OR INTELLECTUAL PROPERTY RIGHT OF TI, ITS SUPPLIERS/LICENSORS OR ANY OTHER THIRD PARTY, TO USE THE EVM IN ANY FINISHED END-USER OR READY-TO-USE FINAL PRODUCT, OR FOR ANY INVENTION, DISCOVERY OR IMPROVEMENT, REGARDLESS OF WHEN MADE, CONCEIVED OR ACQUIRED.
 7. *USER'S INDEMNITY OBLIGATIONS AND REPRESENTATIONS.* USER WILL DEFEND, INDEMNIFY AND HOLD TI, ITS LICENSORS AND THEIR REPRESENTATIVES HARMLESS FROM AND AGAINST ANY AND ALL CLAIMS, DAMAGES, LOSSES, EXPENSES, COSTS AND LIABILITIES (COLLECTIVELY, "CLAIMS") ARISING OUT OF OR IN CONNECTION WITH ANY HANDLING OR USE OF THE EVM THAT IS NOT IN ACCORDANCE WITH THESE TERMS. THIS OBLIGATION SHALL APPLY WHETHER CLAIMS ARISE UNDER STATUTE, REGULATION, OR THE LAW OF TORT, CONTRACT OR ANY OTHER LEGAL THEORY, AND EVEN IF THE EVM FAILS TO PERFORM AS DESCRIBED OR EXPECTED.

8. *Limitations on Damages and Liability:*

8.1 *General Limitations.* IN NO EVENT SHALL TI BE LIABLE FOR ANY SPECIAL, COLLATERAL, INDIRECT, PUNITIVE, INCIDENTAL, CONSEQUENTIAL, OR EXEMPLARY DAMAGES IN CONNECTION WITH OR ARISING OUT OF THESE TERMS OR THE USE OF THE EVMS , REGARDLESS OF WHETHER TI HAS BEEN ADVISED OF THE POSSIBILITY OF SUCH DAMAGES. EXCLUDED DAMAGES INCLUDE, BUT ARE NOT LIMITED TO, COST OF REMOVAL OR REINSTALLATION, ANCILLARY COSTS TO THE PROCUREMENT OF SUBSTITUTE GOODS OR SERVICES, RETESTING, OUTSIDE COMPUTER TIME, LABOR COSTS, LOSS OF GOODWILL, LOSS OF PROFITS, LOSS OF SAVINGS, LOSS OF USE, LOSS OF DATA, OR BUSINESS INTERRUPTION. NO CLAIM, SUIT OR ACTION SHALL BE BROUGHT AGAINST TI MORE THAN TWELVE (12) MONTHS AFTER THE EVENT THAT GAVE RISE TO THE CAUSE OF ACTION HAS OCCURRED.

8.2 *Specific Limitations.* IN NO EVENT SHALL TI'S AGGREGATE LIABILITY FROM ANY USE OF AN EVM PROVIDED HEREUNDER, INCLUDING FROM ANY WARRANTY, INDEMNITY OR OTHER OBLIGATION ARISING OUT OF OR IN CONNECTION WITH THESE TERMS, , EXCEED THE TOTAL AMOUNT PAID TO TI BY USER FOR THE PARTICULAR EVM(S) AT ISSUE DURING THE PRIOR TWELVE (12) MONTHS WITH RESPECT TO WHICH LOSSES OR DAMAGES ARE CLAIMED. THE EXISTENCE OF MORE THAN ONE CLAIM SHALL NOT ENLARGE OR EXTEND THIS LIMIT.

9. *Return Policy.* Except as otherwise provided, TI does not offer any refunds, returns, or exchanges. Furthermore, no return of EVM(s) will be accepted if the package has been opened and no return of the EVM(s) will be accepted if they are damaged or otherwise not in a resalable condition. If User feels it has been incorrectly charged for the EVM(s) it ordered or that delivery violates the applicable order, User should contact TI. All refunds will be made in full within thirty (30) working days from the return of the components(s), excluding any postage or packaging costs.

10. *Governing Law:* These terms and conditions shall be governed by and interpreted in accordance with the laws of the State of Texas, without reference to conflict-of-laws principles. User agrees that non-exclusive jurisdiction for any dispute arising out of or relating to these terms and conditions lies within courts located in the State of Texas and consents to venue in Dallas County, Texas. Notwithstanding the foregoing, any judgment may be enforced in any United States or foreign court, and TI may seek injunctive relief in any United States or foreign court.

Mailing Address: Texas Instruments, Post Office Box 655303, Dallas, Texas 75265
Copyright © 2023, Texas Instruments Incorporated

IMPORTANT NOTICE AND DISCLAIMER

TI PROVIDES TECHNICAL AND RELIABILITY DATA (INCLUDING DATA SHEETS), DESIGN RESOURCES (INCLUDING REFERENCE DESIGNS), APPLICATION OR OTHER DESIGN ADVICE, WEB TOOLS, SAFETY INFORMATION, AND OTHER RESOURCES "AS IS" AND WITH ALL FAULTS, AND DISCLAIMS ALL WARRANTIES, EXPRESS AND IMPLIED, INCLUDING WITHOUT LIMITATION ANY IMPLIED WARRANTIES OF MERCHANTABILITY, FITNESS FOR A PARTICULAR PURPOSE OR NON-INFRINGEMENT OF THIRD PARTY INTELLECTUAL PROPERTY RIGHTS.

These resources are intended for skilled developers designing with TI products. You are solely responsible for (1) selecting the appropriate TI products for your application, (2) designing, validating and testing your application, and (3) ensuring your application meets applicable standards, and any other safety, security, regulatory or other requirements.

These resources are subject to change without notice. TI grants you permission to use these resources only for development of an application that uses the TI products described in the resource. Other reproduction and display of these resources is prohibited. No license is granted to any other TI intellectual property right or to any third party intellectual property right. TI disclaims responsibility for, and you will fully indemnify TI and its representatives against, any claims, damages, costs, losses, and liabilities arising out of your use of these resources.

TI's products are provided subject to [TI's Terms of Sale](#) or other applicable terms available either on [ti.com](https://www.ti.com) or provided in conjunction with such TI products. TI's provision of these resources does not expand or otherwise alter TI's applicable warranties or warranty disclaimers for TI products.

TI objects to and rejects any additional or different terms you may have proposed.

Mailing Address: Texas Instruments, Post Office Box 655303, Dallas, Texas 75265

Copyright © 2025, Texas Instruments Incorporated