

Cut-Off Switch in High-Current Motor-Drive Applications

Matt Hein

Analog Motor Drive

ABSTRACT

Some motor drive applications with high-current motors require power switches to decrease quiescent current or to get an alternate load turnoff path. Because the system output power is very high, discrete pass elements must be implemented. This document describes different topologies for implementing a "cut-off switch."

Contents

1	Introduction	1
2	The Discrete PMOS Cut-Off Switch	2
3	The Discrete NMOS Cut-Off Switch	2
4	The Upstream NMOS Cut-Off Switch	3
5	The NMOS Cut-Off Switch With Downstream Motor Driver	4
6	References	5

List of Figures

1	Cut-Off Switch	2
2	Discrete PMOS Cut-Off Switch	2
3	Discrete NMOS Cut-Off Switch	3
4	Upstream NMOS Cut-Off Switch	3
5	NMOS Cut-Off Switch With Downstream Motor Driver	4

List of Tables

1	Device Options	3
2	Device Options	4

Trademarks

All trademarks are the property of their respective owners.

1 Introduction

A power switch is an electronic relay designed to prevent the flow of current in a system and is located between some load circuit and the system supply. Any power-consuming circuit can be a load. A system supply can be an AC/DC generated regulated voltage (12 V, 24 V, 48 V, and so forth) or a battery (lead acid, lithium ion, nickel cadmium, or other battery types). For a more detailed look at different power switch topologies and solutions, see the [Basics of Power Switches application report](#).

Power switches have several uses in both regulated supply and battery-powered applications:

- To decrease quiescent current in standby mode
- To provide an alternate path for load turnoff
- To help power distribution and sequencing

High-current motor drive systems use a discrete MOSFET as the power switch because integrated switch devices are limited in the power that they can drive. High-current motor drive systems can drive motors over 500 W.

High-current motor-drive systems can use power switches to reduce the quiescent current in standby mode and an alternate path for load turn-off. However, because the motor output can be >500 W, the pass element of the power switch must be a discrete MOSFET because integrated switch devices are limited in the power that they can drive. These systems will implement the power switch in series with the supply (as opposed to on the return ground path) to prevent the switch from interfering with the complexity of the motor-drive circuit grounding.

The term “power switch” (or “load switch”) is a general term. This document uses the term “cut-off switch” to describe a high-side discrete MOSFET power switch.

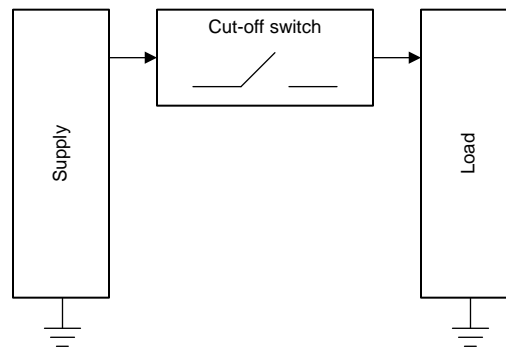

Figure 1. Cut-Off Switch

2 The Discrete PMOS Cut-Off Switch

The P-channel MOSFET (PMOS) is the simplest cut-off switch implementation, but there are two primary disadvantages. A PMOS is more expensive than N-channel MOSFETs (NMOS). The maximum power that can be achieved with PMOS solutions is limited (because the $R_{DS(ON)}$ of PMOS is higher than NMOS.) For very-high-power and cost-sensitive systems this circuit does not provide a good solution.

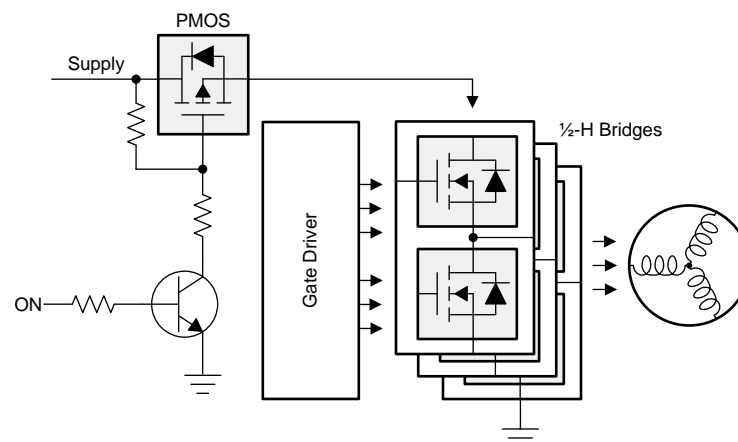

Figure 2. Discrete PMOS Cut-Off Switch

3 The Discrete NMOS Cut-Off Switch

The alternative is to use an NMOS as the pass element to prevent cost and power concerns of a PMOS. The major disadvantage of using the NMOS is that they will require a positive V_{GS} (gate-to-source) to turn on. An external boost circuit (either DC/DC or charge pump) must be used to generate a gate drive voltage that is greater than the supply. The requirement of an additional voltage regulator adds significant design complexity and cost.

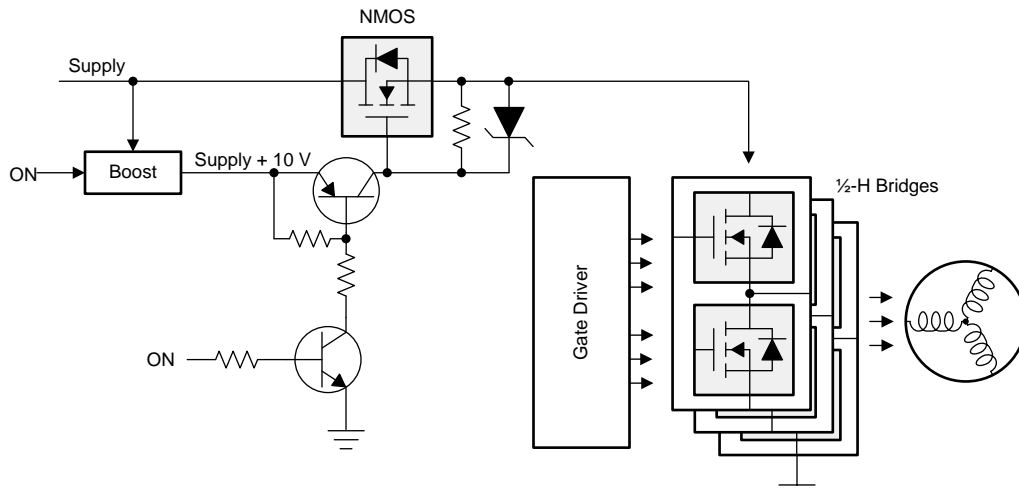

Figure 3. Discrete NMOS Cut-Off Switch

4 The Upstream NMOS Cut-Off Switch

Some solutions use a high-side gate driver (or controller) that removes the need for an external boost circuit. This solution is “upstream” because the gate drive voltage comes from the supply. A gate driver designed for this purpose can also integrate supply monitoring to provide protection against overvoltage and overcurrent events. For example, the [TPS2492](#) device has system power limiting as well as a current monitor output, so a microcontroller can measure the current flowing through the cut-off switch when it is closed.

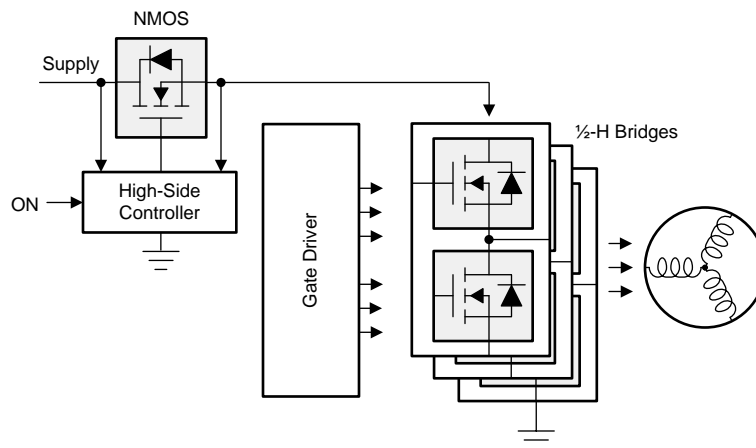

Figure 4. Upstream NMOS Cut-Off Switch

Table 1. Device Options

Product	Maximum Voltage	Description
LM5060	65 V	High-Side Protection Controller with Low Quiescent Current
LM5069	65 V	High-Side Protection Controller with Low Quiescent Current with Power Limiting
TPS2490, TPS2491	80 V	Positive High-Voltage Power-Limiting Controller
TPS2492/3	80 V	Positive High-Voltage Power-Limiting Controller with Analog Current Monitor Output

5 The NMOS Cut-Off Switch With Downstream Motor Driver

To achieve a hybrid solution between the completely-discrete and fully-integrated solution, the designer can first look to solve the problem of Supply + 10 V to turn on the NMOS. In many motor drive applications, NMOS are already used for high-side MOSFETs in a ½-h bridge configuration. Most motor gate drivers integrate a boost circuit or charge pump to turn on the high-side NMOS. The designer can potentially use this “downstream” supply to power our high-side cut-off switch.

The gate voltage on the NMOS must be a Supply + 10 V to close the cut-off switch. The cut-off switch can be closed indefinitely which requires a constant voltage. Because of this, gate drivers that use a bootstrap architecture cannot be used because they do not generate the needed constant voltage above the supply.

If a charge pump is downstream, the system must have a way to turn on before the charge pump is active. Adding two diodes to the discrete NMOS circuit lets the system power up before the charge pump is active. These diodes will OR the system supply with the charge pump. When the cut-off switch is activated, the NMOS will act as a diode because the gate and drain are effectively shorted. After the motor gate driver has powered up, the charge pump will override the supply, and the NMOS will be fully enhanced.

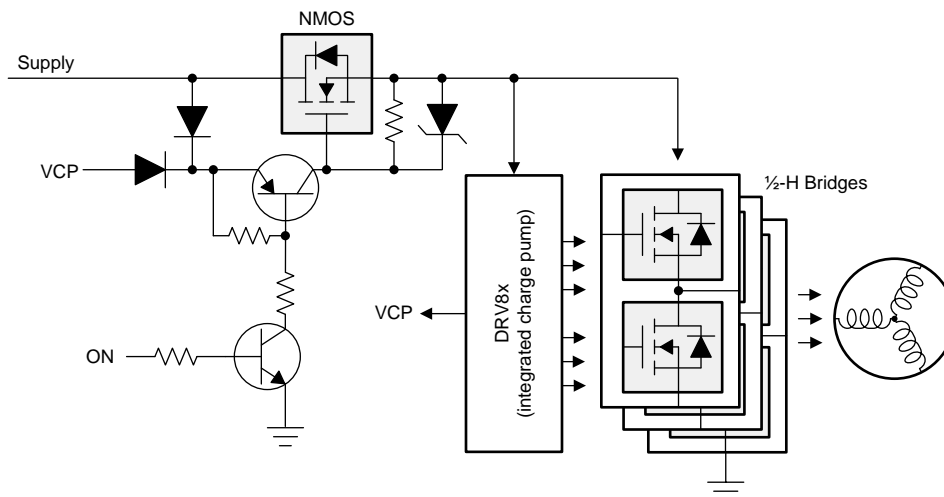

Figure 5. NMOS Cut-Off Switch With Downstream Motor Driver

Table 2. Device Options

Product	Maximum Voltage	Description
DRV3205-Q1	60 V	Automotive Gate Driver with Three Current Shunt Amps and Enhanced Protection and Diagnostics
DRV3245Q-Q1	45 V	Automotive Gate Driver Unit (GDU) With High Performance Sensing, Protection and Diagnostics
DRV8304	38 V	Three-Phase Smart Gate Driver With Three Current Shunt Amplifiers
DRV8305	45 V	Three Phase Gate Driver with Three Integrated Current Shunt Amplifiers
DRV8305-Q1	45 V	Automotive Three Phase Gate Driver with Three Integrated Current Shunt Amplifiers
DRV8306	38 V	Brushless-DC Smart Gate Driver With Trapezoidal Commutation
DRV8320 , DRV8320R , DRV8323 , DRV8323R	60 V	Three-Phase Smart Gate Driver With Optional Buck Regulator and Optional Three Current Shunt Amplifiers
DRV8350 , DRV8350R , DRV8353 , DRV8353R	100 V	Three-Phase Smart Gate Driver With Optional Buck Regulator and Optional Three Current Shunt Amplifiers
DRV8701	45 V	Brushed DC Motor Gate Driver
DRV8702-Q1 , DRV8703-Q1	45 V	Automotive Brushed DC Motor Gate Driver

6 References

- Texas Instruments, [Basics of Power Switches application report](#)

Revision History

NOTE: Page numbers for previous revisions may differ from page numbers in the current version.

Changes from Original (July 2018) to A Revision	Page
• Added the DRV835x devices to the <i>Device Options</i> table.....	4

IMPORTANT NOTICE FOR TI DESIGN INFORMATION AND RESOURCES

Texas Instruments Incorporated ("TI") technical, application or other design advice, services or information, including, but not limited to, reference designs and materials relating to evaluation modules, (collectively, "TI Resources") are intended to assist designers who are developing applications that incorporate TI products; by downloading, accessing or using any particular TI Resource in any way, you (individually or, if you are acting on behalf of a company, your company) agree to use it solely for this purpose and subject to the terms of this Notice.

TI's provision of TI Resources does not expand or otherwise alter TI's applicable published warranties or warranty disclaimers for TI products, and no additional obligations or liabilities arise from TI providing such TI Resources. TI reserves the right to make corrections, enhancements, improvements and other changes to its TI Resources.

You understand and agree that you remain responsible for using your independent analysis, evaluation and judgment in designing your applications and that you have full and exclusive responsibility to assure the safety of your applications and compliance of your applications (and of all TI products used in or for your applications) with all applicable regulations, laws and other applicable requirements. You represent that, with respect to your applications, you have all the necessary expertise to create and implement safeguards that (1) anticipate dangerous consequences of failures, (2) monitor failures and their consequences, and (3) lessen the likelihood of failures that might cause harm and take appropriate actions. You agree that prior to using or distributing any applications that include TI products, you will thoroughly test such applications and the functionality of such TI products as used in such applications. TI has not conducted any testing other than that specifically described in the published documentation for a particular TI Resource.

You are authorized to use, copy and modify any individual TI Resource only in connection with the development of applications that include the TI product(s) identified in such TI Resource. NO OTHER LICENSE, EXPRESS OR IMPLIED, BY ESTOPPEL OR OTHERWISE TO ANY OTHER TI INTELLECTUAL PROPERTY RIGHT, AND NO LICENSE TO ANY TECHNOLOGY OR INTELLECTUAL PROPERTY RIGHT OF TI OR ANY THIRD PARTY IS GRANTED HEREIN, including but not limited to any patent right, copyright, mask work right, or other intellectual property right relating to any combination, machine, or process in which TI products or services are used. Information regarding or referencing third-party products or services does not constitute a license to use such products or services, or a warranty or endorsement thereof. Use of TI Resources may require a license from a third party under the patents or other intellectual property of the third party, or a license from TI under the patents or other intellectual property of TI.

TI RESOURCES ARE PROVIDED "AS IS" AND WITH ALL FAULTS. TI DISCLAIMS ALL OTHER WARRANTIES OR REPRESENTATIONS, EXPRESS OR IMPLIED, REGARDING TI RESOURCES OR USE THEREOF, INCLUDING BUT NOT LIMITED TO ACCURACY OR COMPLETENESS, TITLE, ANY EPIDEMIC FAILURE WARRANTY AND ANY IMPLIED WARRANTIES OF MERCHANTABILITY, FITNESS FOR A PARTICULAR PURPOSE, AND NON-INFRINGEMENT OF ANY THIRD PARTY INTELLECTUAL PROPERTY RIGHTS.

TI SHALL NOT BE LIABLE FOR AND SHALL NOT DEFEND OR INDEMNIFY YOU AGAINST ANY CLAIM, INCLUDING BUT NOT LIMITED TO ANY INFRINGEMENT CLAIM THAT RELATES TO OR IS BASED ON ANY COMBINATION OF PRODUCTS EVEN IF DESCRIBED IN TI RESOURCES OR OTHERWISE. IN NO EVENT SHALL TI BE LIABLE FOR ANY ACTUAL, DIRECT, SPECIAL, COLLATERAL, INDIRECT, PUNITIVE, INCIDENTAL, CONSEQUENTIAL OR EXEMPLARY DAMAGES IN CONNECTION WITH OR ARISING OUT OF TI RESOURCES OR USE THEREOF, AND REGARDLESS OF WHETHER TI HAS BEEN ADVISED OF THE POSSIBILITY OF SUCH DAMAGES.

You agree to fully indemnify TI and its representatives against any damages, costs, losses, and/or liabilities arising out of your non-compliance with the terms and provisions of this Notice.

This Notice applies to TI Resources. Additional terms apply to the use and purchase of certain types of materials, TI products and services. These include; without limitation, TI's standard terms for semiconductor products (<http://www.ti.com/sc/docs/stdterms.htm>), [evaluation modules](#), and [samples](http://www.ti.com/sc/docs/sampterm.htm) (<http://www.ti.com/sc/docs/sampterm.htm>).

Mailing Address: Texas Instruments, Post Office Box 655303, Dallas, Texas 75265
Copyright © 2018, Texas Instruments Incorporated