

How to Build a Small, Functionally Safe 48-V, 30-kW MHEV Motor-Drive System



Issac K.C. Hsu

Product Marketing Engineer

1 Introduction

Global initiatives to reduce greenhouse gas (GHG) emissions have sparked an automobile evolution that requires automobile manufacturers to increase powertrain electrification in new vehicles. Mild hybrid electric vehicles (MHEVs), which employ 48-V motor-drive systems to help reduce the GHG emissions from the internal combustion engine (ICE), have emerged as an attractive option to achieve compliance, because the implementation cost is much less than that of a full HEV. This white paper explains how to achieve Automotive Safety Integrity Level D (ASIL D) functional safety in MHEVs while providing up to 30 kW of motor power and high integration to help reduce board space using the [DRV3255-Q1](#) 48-V BLDC motor driver.

2 MHEVs and the use of 48-V Motor-Drive Systems

Multiple global initiatives to reduce greenhouse gas (GHG) emissions in countries such as the United States, Japan and China, as well as the European Union, have sparked an automobile evolution. For example, the National Highway Traffic Safety Administration under the U.S. Department of Transportation published its final environmental impact statement^[1] in March 2020 governing the fuel economy of vehicles from year 2021 to 2026. Section 2.2.2.3 of the statement estimates that combined passenger cars and trucks will have a corporate average fuel economy of 40.4 mpg by 2026. The European Union also committed to reduce GHG emissions by 40% by the year 2030 (compared to 1990) within the Paris agreement (COP21)^[2].

Automobile manufacturers have several ways to achieve GHG emission reduction goals. One is to build mild hybrid electric vehicles (MHEVs), which incorporate 48-V motor-drive systems. Since an internal combustion engine (ICE) emits GHGs during combustion, the ICE in an MHEV turns off while the vehicle is coasting which helps reduce the GHG emissions from the ICE. When this happens, the 48-V motor-drive system charges the 48-V battery to provide electricity for the vehicle. MHEVs are an attractive option for automobile manufacturers to meet GHG emission reduction goals because the implementation cost is much less than that of a full HEV and they provide design flexibility.

The 48-V motor-drive system in an MHEV can be bolted to the transmission system in different places based on design goals. [Figure 2-1](#) illustrates the connection points along the transmission system.

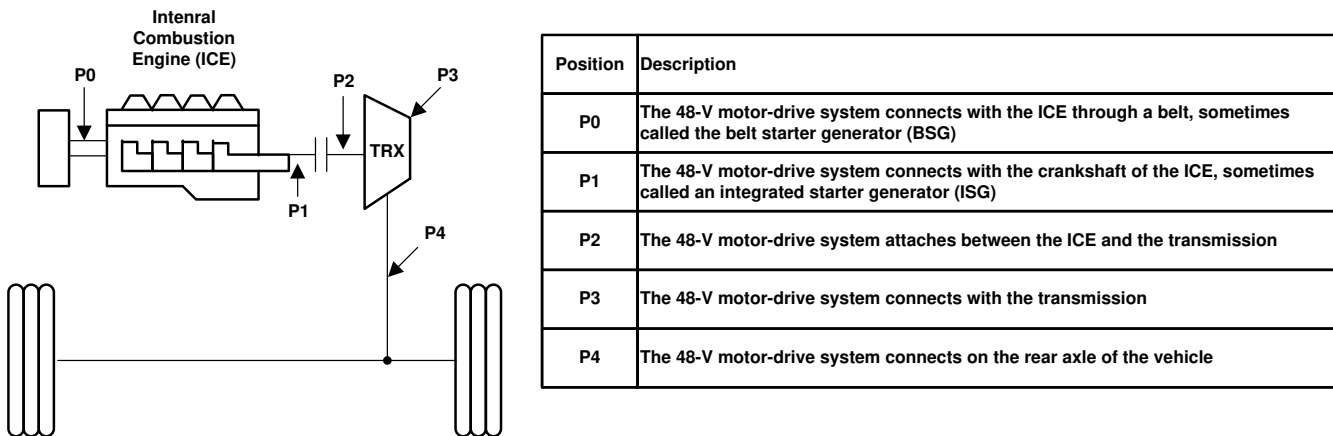

Figure 2-1. Motor-Drive Connection Points (48 V) Along the Transmission System

With the 48-V motor-drive system located at P0 or P1, it functions as a starter generator, as it is connected to the ICE performing both starter and generator functions. When located at P2, P3, or P4, the 48-V motor-drive system acts as a motor generator.

3 Design Challenges of a 48-V Motor-Drive System

There are several factors leading to a successful design for a 48-V motor-drive system: high-power motor driving, safety and small size. High-power motor driving is important to help achieve GHG emission reductions. Safety is important because the 48-V motor generates power during coasting and braking, and it provides power assistance when the engine starts if acting as a starter generator. Small size is important because the 48-V motor system sits within a limited engine compartment space near the ICE.

A typical 48-V motor-drive system requires 10 kW to 30 kW of electrical power for automotive powertrain applications. A 48-V and 12-V dual supply system can support this level of high-power motor driving. There are different power-supply architectures for high-power 48-V motor drivers.

Figure 3-1 illustrates the most common 48-V motor-driver architecture. A 48-V battery connects to the motor with a DC/DC buck regulator downconverting the supply to the motor driver, a power-management integrated circuit and a microcontroller from 48-V to 12-V. A 12-V supply from the 12-V battery is diode-ORed to make sure that the 12-V supply exists for essential motor-control functions. The voltage of the 48-V supply should follow the standard covered by International Organization for Standardization (ISO) 21780, which is illustrated in Figure 3-2.

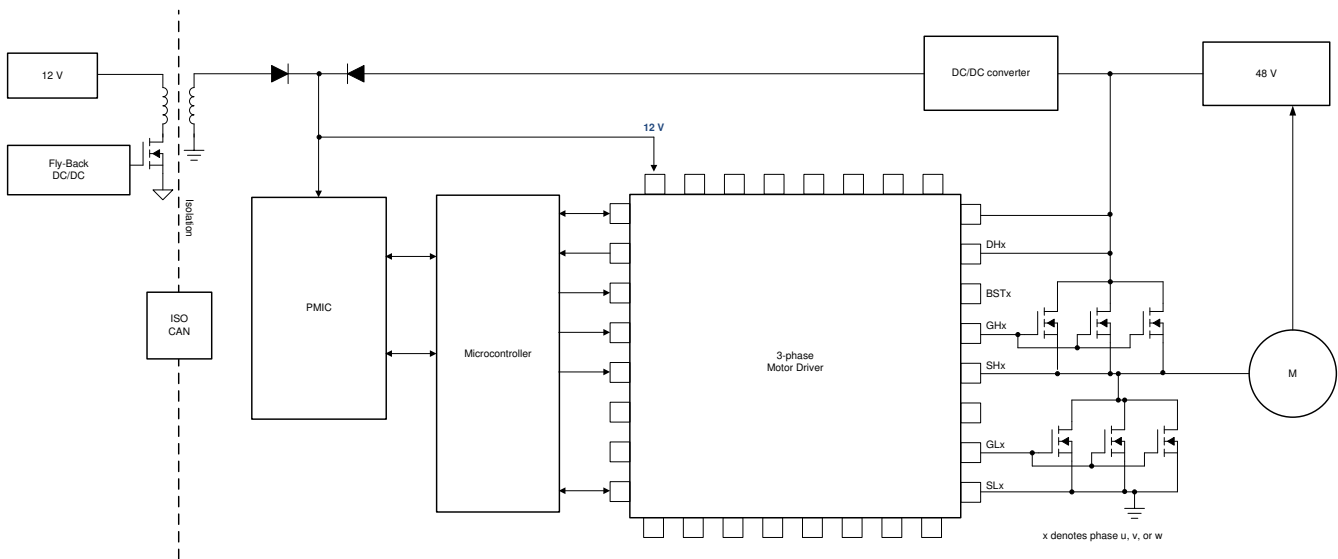

Figure 3-1. Common Power-Supply Architecture for High-Power 48-V Motor Drivers

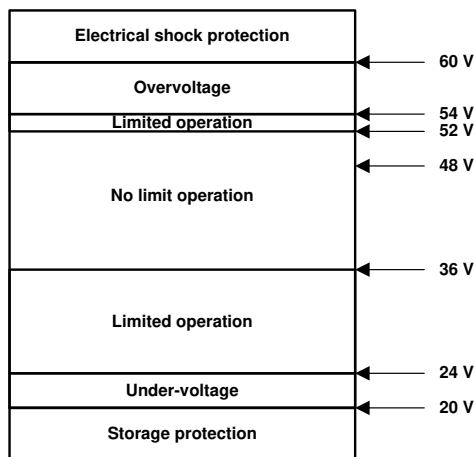

Figure 3-2. ISO 21780 Specifications for 48-V Voltage Levels

4 Considerations in High-Power Motor Driving

As illustrated in Figure 3-1, a 48-V high-power motor driver drives external metal-oxide semiconductor field-effect transistors (MOSFETs) to spin the motor. To support 10 kW to 30 kW of power, these external MOSFETs need to support 200 A to more than 600 A of current. Minimizing the $R_{DS(on)}$ of the MOSFETs can help reduce heat dissipation and conduction losses; in some cases, it is better to parallel multiple MOSFETs per channel, since the heat dissipation of each MOSFET will be distributed. Thus, the total gate charge of the MOSFETs is large – supporting huge current ranges such as 300 nC to 700 nC. In extreme cases, supporting 30 kW of power, the total gate charge of the MOSFETs might reach as high as 1,000 nC.

It is important to optimize the heat dissipation caused by switching losses and ensure that the whole solution meets electromagnetic compatibility (EMC) specifications. The rise and fall times of the V_{DS} of the MOSFETs determine the switching losses. A faster rise and fall time can reduce switching losses, but will affect EMC performance. Figure 4-1 shows the relationship between the gate charge of the MOSFET and the fall time during MOSFET switching.

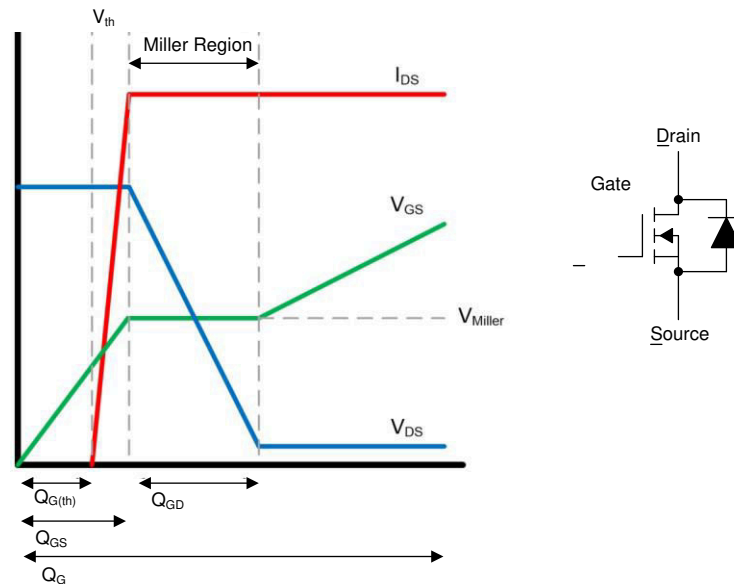

Figure 4-1. Fall Time of V_{DS} vs Gate Charge

As Figure 3-2 shows, the 48-V battery could exceed the nominal voltage and have transient overshoot higher than the 60-V limit. Conversely, the motor-driver phase-connecting pins must sustain a negative transient voltage, since the reverse-recovery time of the parasitic diodes of the MOSFETs will cause them to react slowly. It is challenging to select a motor driver that maintains normal operations at voltages higher than 48 V while still being able to handle a negative voltage.

The integrated DRV3255-Q1 48-V BLDC motor driver is designed to drive high-gate-charge MOSFETs: the peak source current of the gate-driver output is 3.5 A and the peak sink current of the gate-driver output is 4.5 A. With such high current-driving capability, it is possible to shorten the rise and fall time of the V_{DS} of the MOSFETs, even with 1,000 nC of gate charge. Alternatively, the DRV3255-Q1 implements selectable gate-driver output current levels. It helps system designers fine-tune the rise and fall time through the adjustable current levels to optimize between switching losses, which in turn affects heat dissipation and EMC performance.

The operating maximum voltage for the high-side MOSFET gate-driver bootstrap pin of the DRV3255-Q1 is rated at 105 V. Together with the continuous operating maximum motor-supply pin voltage of 90 V, the DRV3255-Q1 supports true 90-V operation when spinning 48-V motors. The most negative transient voltage of the bootstrap pin, high-side MOSFET source-sensing pins and low-side MOSFET source-sensing pins are rated at -15 V.

5 Safety and Size Considerations of 48-V Motor-Drive Systems

Implementing a safe high-power motor driver requires protection, since the current flowing through the motor can be rated above 200 A. One of the key concerns for a 48-V motor-drive system is that the motor can generate unwanted power, leading to overvoltage conditions that could damage the system. The system should have a mechanism to control the functional MOSFETs (appropriately turned on or off) to protect the system from further damage caused by overvoltage conditions. Such protection typically requires external safe logic and comparators.

The DRV3255-Q1 integrates active short-circuit logic that enables system designers to decide the response to a MOSFET short circuit. Instead of disabling all MOSFETs in response to a fault condition, the device is configurable to enable all high-side MOSFETs or all low-side MOSFETs, or dynamically enable either all low-side or high-side MOSFETs. The device response delay time of the active short-circuit input is programmable and configurable through the Serial Peripheral Interface (SPI) register. Additionally, the DRV3255-Q1 provides full diagnostic coverage and is designed according to ISO 26262, enabling a functional safety motor-drive system up to Automotive Safety Integrity Level D (ASIL D).

Figure 5-1 shows a typical motor-driver block diagram for a 48-V high-power motor-driver design. Implementing a safe and robust motor-drive system requires clamping diodes, external drive circuitry, a sink-path resistor and diodes, comparators, and external safe logic. The DRV3255-Q1 integrates external logic and comparators, supports up to 105 V on the bootstrap pin, handles a negative transient voltage down to -15 V and implements a selectable high-current gate-driver current output. The actual implementation of the 48-V high-power motor-drive system with the DRV3255-Q1 is possible by removing the dotted-line blocks, as shown in Figure 5-2. This simplifies the design and reduces the number of components on the board, thus achieving a compact design that fits in the limited space of an engine compartment.

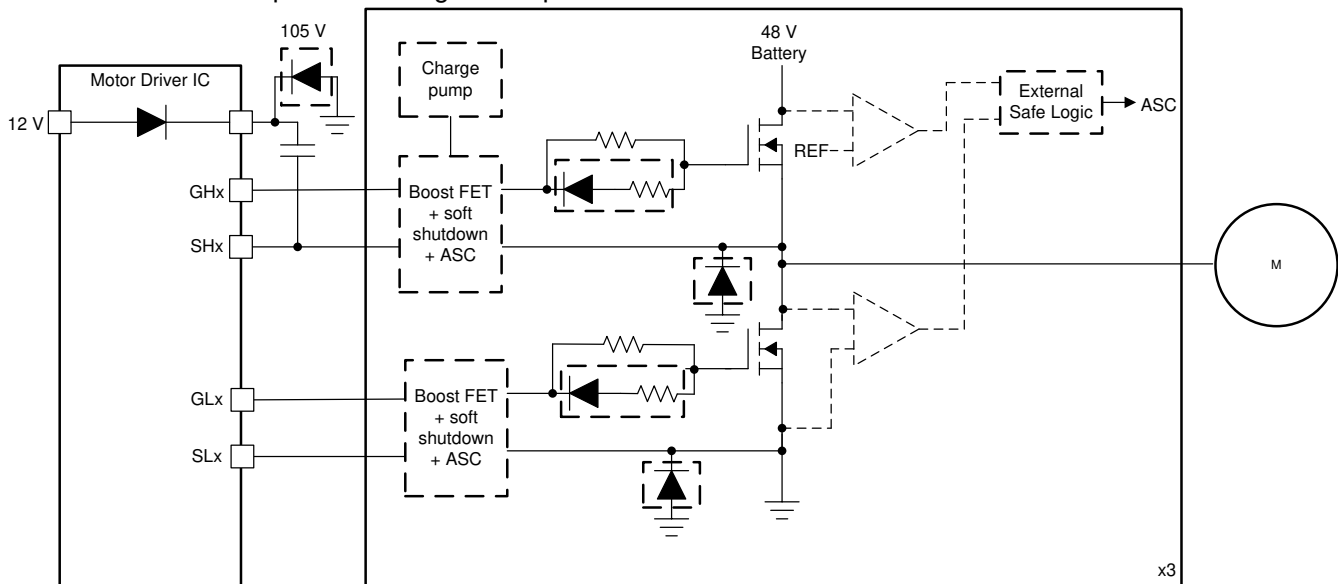

Figure 5-1. Motor-Drive Block Diagram

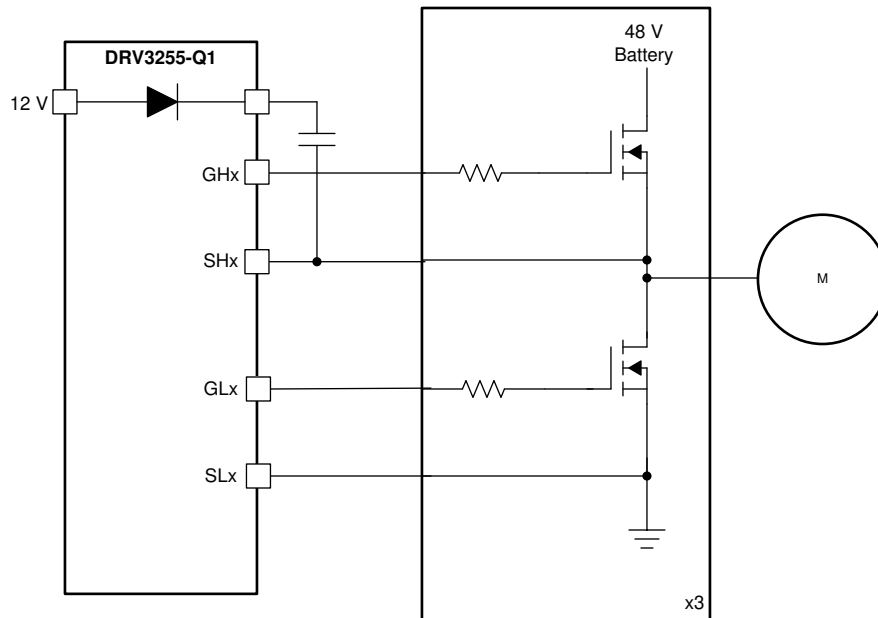

Figure 5-2. Simplified DRV3255-Q1 Motor-Driver Block Diagram

6 Conclusion

The 48-V motor-drive systems are designed to reduce GHG emissions in MHEVs. As a system designer, it is important to design a high-power (10 kW to 30 kW) 48-V motor-drive system that is small in size and functionally safe. The selectable high gate-drive current, high-voltage transient support, active short-circuit logic and functional safety-compliance of the DRV3255-Q1 helps create a high-power, functionally safe and small 48-V MHEV motor-drive system.

7 Reference

1. "Final Environmental Impact Statement – The Safer Affordable Fuel-Efficient (SAFE) Vehicles Rule for Model Years 2021-2026 Passenger Cars and Light Trucks," National Highway Traffic Safety Administration, U.S. Department of Transportation, March 2020 (docket no. NHTSA-2017-0069).
2. "Worldwide Emission Standards and Related Regulations – Passenger Cars/Light and Medium duty Vehicles", CPT Group GmbH, May 2019.

Trademarks

All trademarks are the property of their respective owners.

IMPORTANT NOTICE AND DISCLAIMER

TI PROVIDES TECHNICAL AND RELIABILITY DATA (INCLUDING DATA SHEETS), DESIGN RESOURCES (INCLUDING REFERENCE DESIGNS), APPLICATION OR OTHER DESIGN ADVICE, WEB TOOLS, SAFETY INFORMATION, AND OTHER RESOURCES "AS IS" AND WITH ALL FAULTS, AND DISCLAIMS ALL WARRANTIES, EXPRESS AND IMPLIED, INCLUDING WITHOUT LIMITATION ANY IMPLIED WARRANTIES OF MERCHANTABILITY, FITNESS FOR A PARTICULAR PURPOSE OR NON-INFRINGEMENT OF THIRD PARTY INTELLECTUAL PROPERTY RIGHTS.

These resources are intended for skilled developers designing with TI products. You are solely responsible for (1) selecting the appropriate TI products for your application, (2) designing, validating and testing your application, and (3) ensuring your application meets applicable standards, and any other safety, security, regulatory or other requirements.

These resources are subject to change without notice. TI grants you permission to use these resources only for development of an application that uses the TI products described in the resource. Other reproduction and display of these resources is prohibited. No license is granted to any other TI intellectual property right or to any third party intellectual property right. TI disclaims responsibility for, and you will fully indemnify TI and its representatives against, any claims, damages, costs, losses, and liabilities arising out of your use of these resources.

TI's products are provided subject to [TI's Terms of Sale](#) or other applicable terms available either on ti.com or provided in conjunction with such TI products. TI's provision of these resources does not expand or otherwise alter TI's applicable warranties or warranty disclaimers for TI products.

TI objects to and rejects any additional or different terms you may have proposed.

Mailing Address: Texas Instruments, Post Office Box 655303, Dallas, Texas 75265
Copyright © 2022, Texas Instruments Incorporated