

TI TECH DAYS

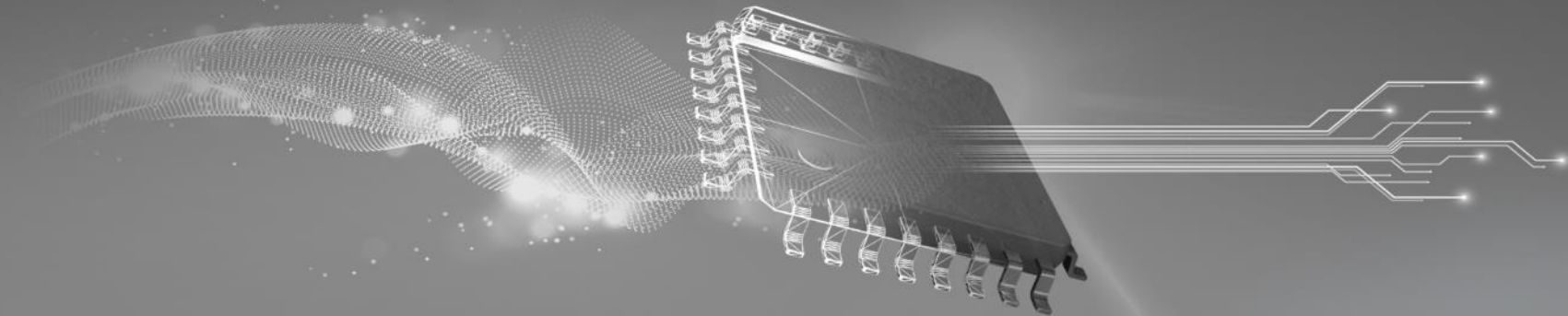

Tips and Tricks for Addressing EMI Issues in Power Supplies

Pradeep Shenoy, Brian King, Bob Sheehan

Power Design Services (PDS)

Agenda

This presentation will cover the unique challenges of designing power converters to pass EMC requirements.

- **Introduction** to EMI: sources, standards, filters, test setup
- Techniques for **debugging** EMI problems
 - Distinguishing between differential mode and common mode noise
- **Design example** showing path to passing CISPR 25

Overview diagram (automotive)

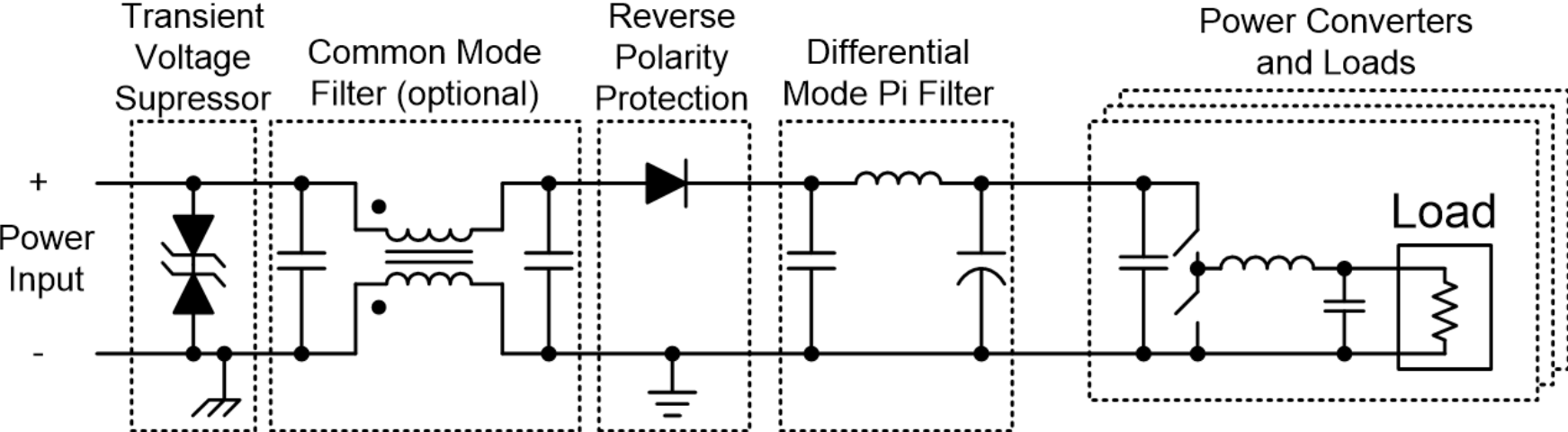
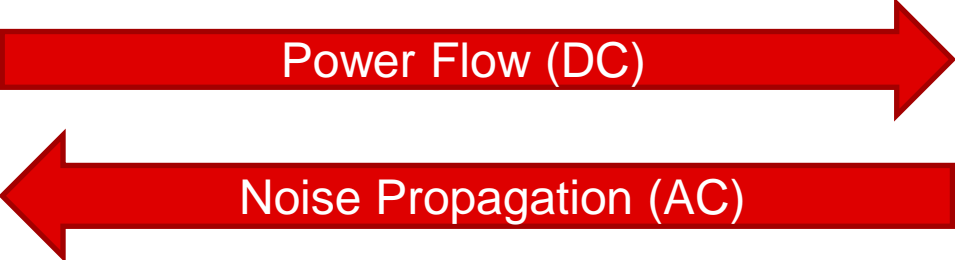

Sources of emissions from within power supplies

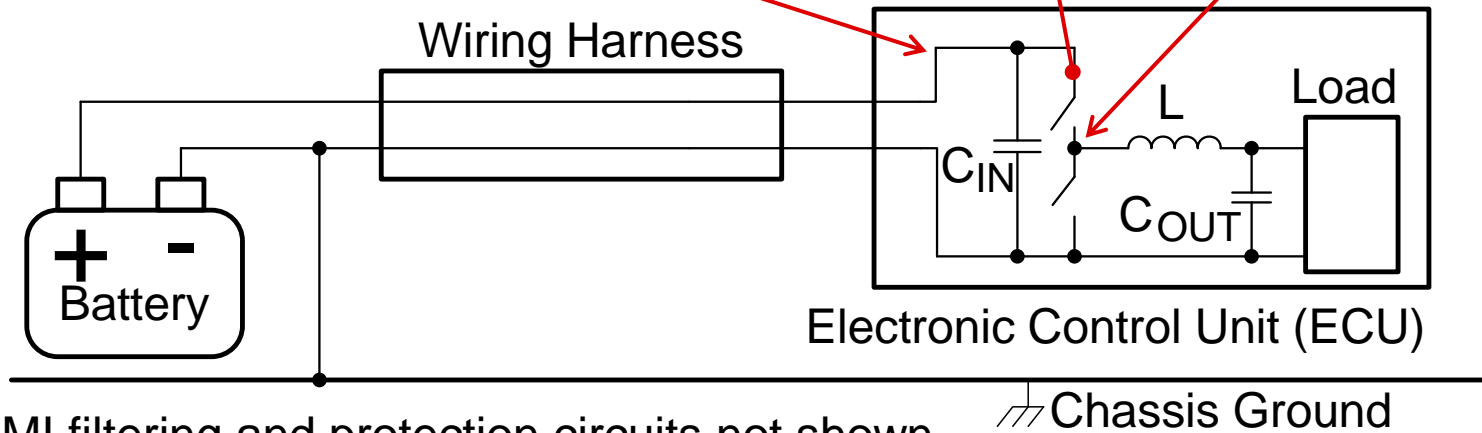
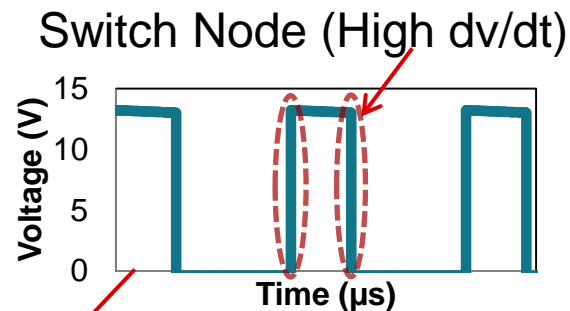
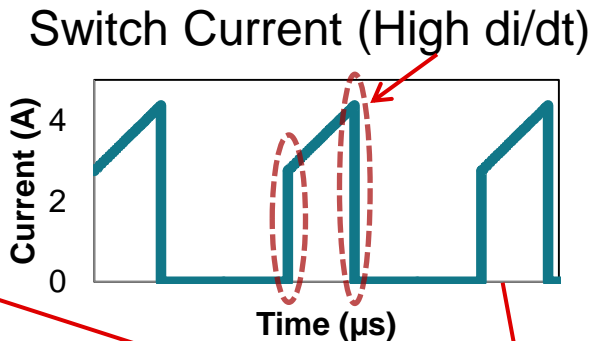
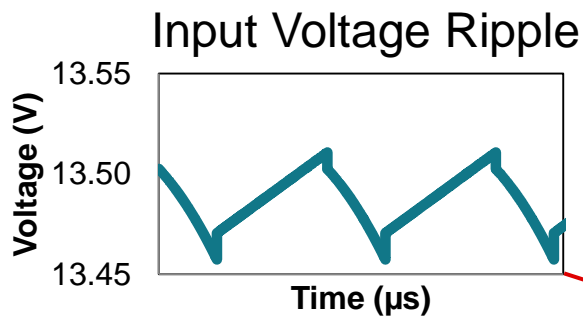

*EMI filtering and protection circuits not shown

Chassis Ground

Frequency spectrum of noise (ripple)

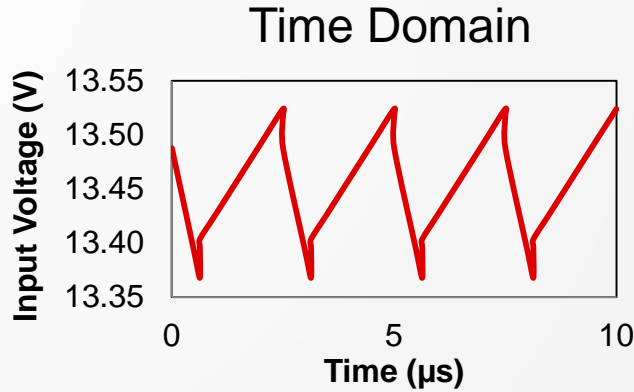

Fourier Transform

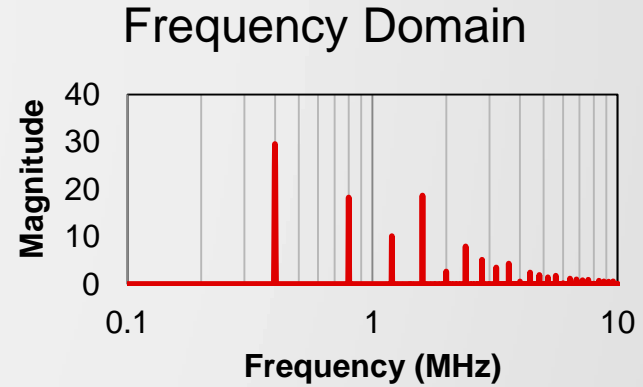

A periodic signal can be expressed as the sum of sinusoidal waveforms

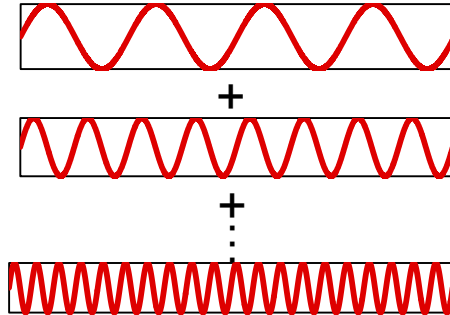

Fourier series

$$f(t) = \sum_{n=0}^{\infty} c_n \cos(n\omega t + \theta_n)$$

Conducted EMI limits

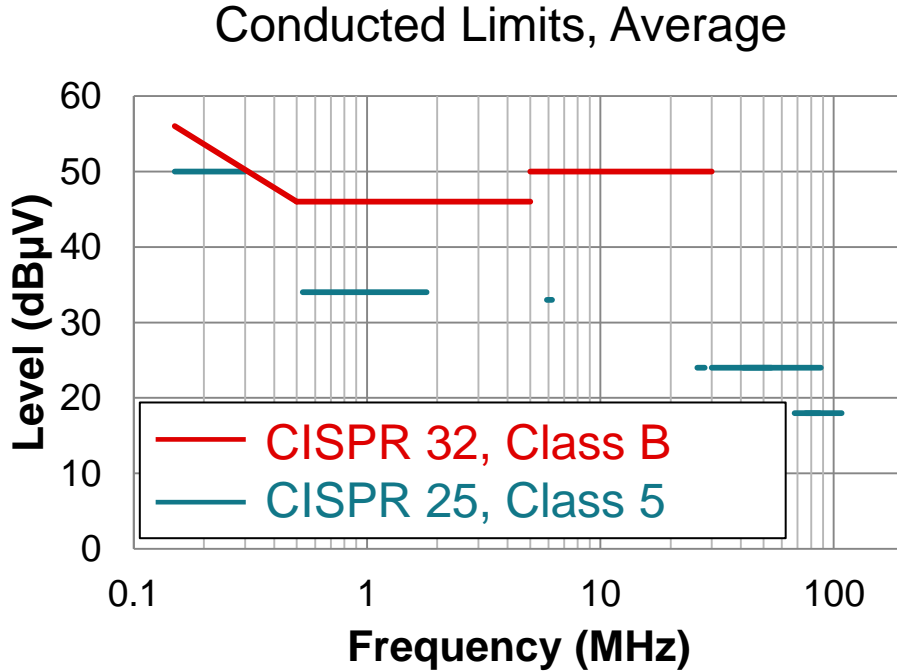

- CISPR 32 (formerly 22) is an EMI standard for **IT/industrial** equipment
 - Continuous line across the frequency spectrum up to 30 MHz
 - Used often for off ac-line applications
- CISPR 25 is a common **automotive** EMI standard
 - Go higher in frequency (108 MHz)
 - Have lower limit levels
 - But have gaps in between frequencies

Differential mode vs. common mode noise

Differential Mode

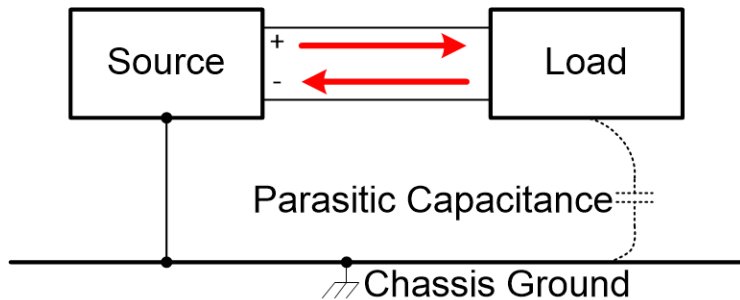

- Signal (noise) flows out on one wire (+) and returns on the other wire (-)
- Increases with load current
- Attenuated with a pi filter

Common Mode

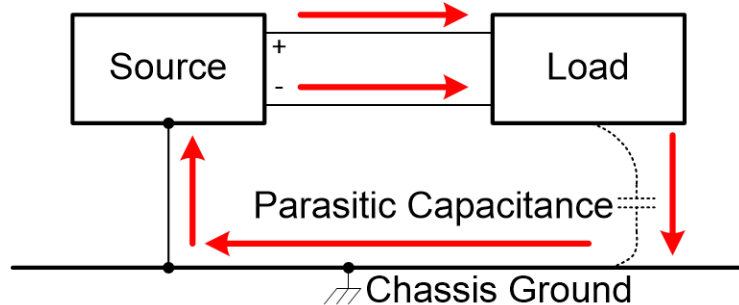

- Noise flows out in the same direction on both wires and returns via stray capacitance and chassis ground
- Mostly independent of load current
- Filtered with a common mode choke

Differential mode EMI filter

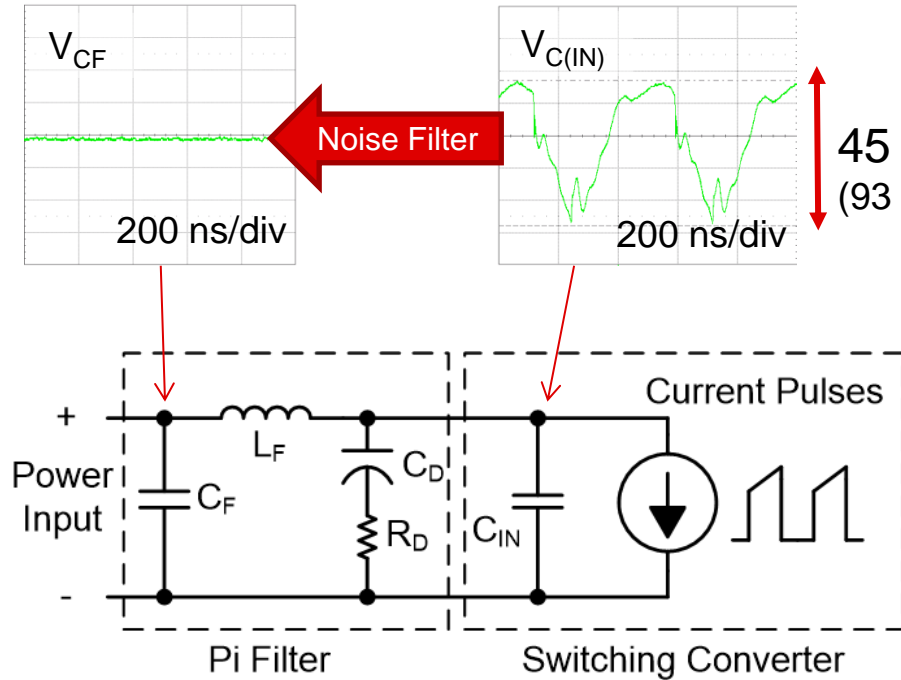

- Buck converters pull pulses of current causing C_{IN} voltage ripple
- A pi (π) filter reduces conducted differential mode noise
 - L_F and C_F form a low pass filter
 - C_D and R_D included for stability (reduce EMI filter output impedance peak)
- Select L_F and C_F to get desired attenuation at f_s

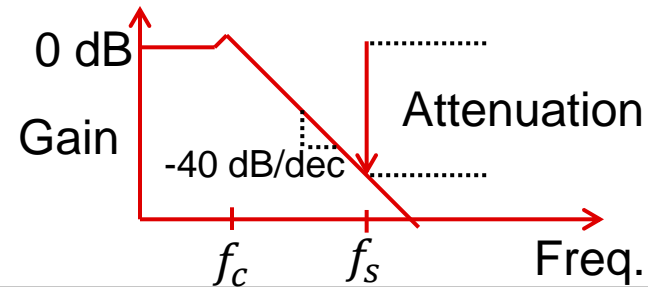

Impact of parasitics

Parasitic Elements in a Pi Filter

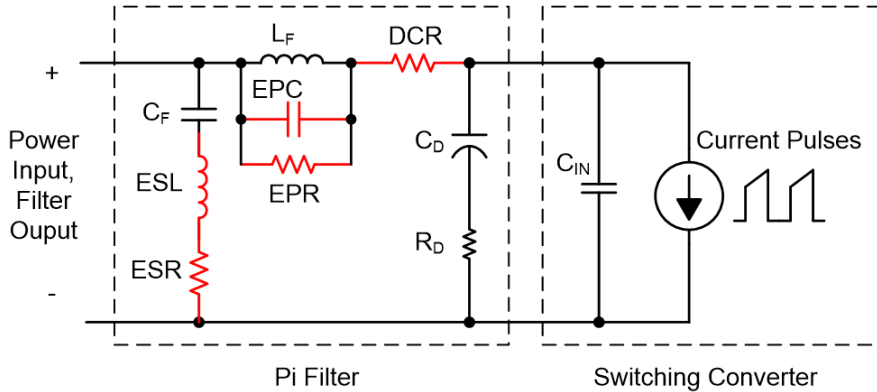

Two Stage Pi Filter

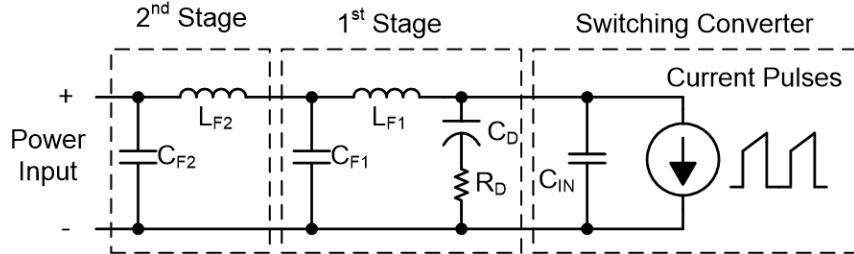

- High frequency performance of pi filters degrade due to parasitic elements

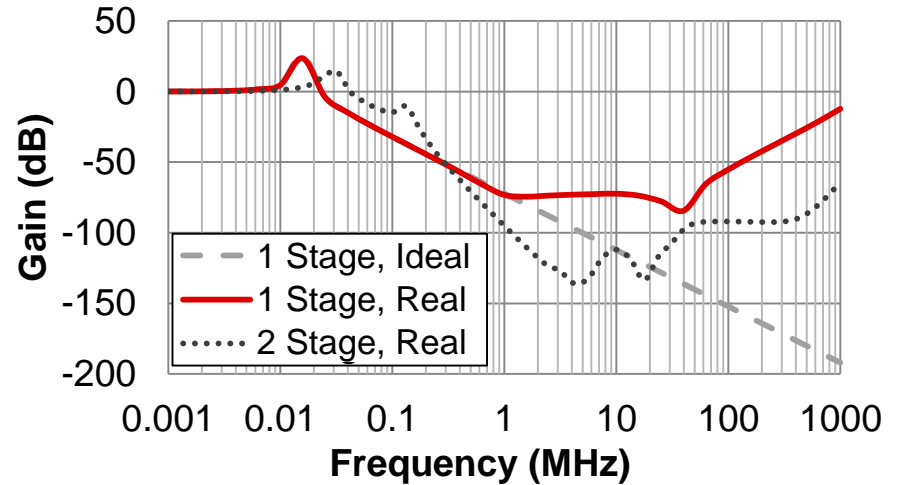

- A two stage pi filter can be used
 - A ferrite bead used in 2nd stage (L_{F2})

Source of common mode noise

- The primary source of common mode noise is **parasitic capacitive coupling**
 - 5 cm is the standard testing height (h) above chassis ground set by CISPR 25
 - Higher/lower would alter parasitic capacitance

- The switch node (V_{SW}) pumps common mode cycle

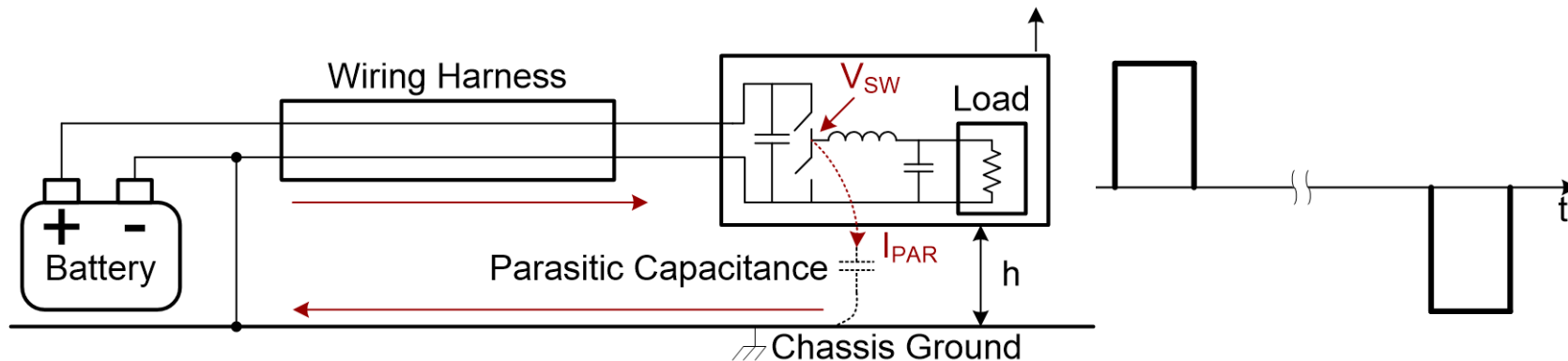
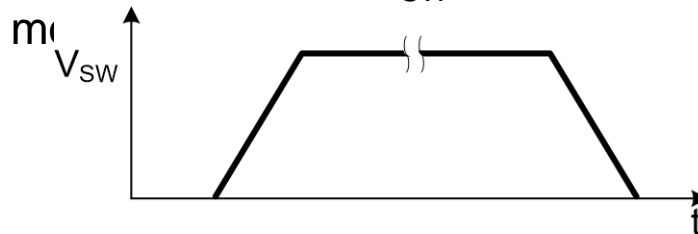

CISPR 25 emissions test setup

Conducted Emissions Setup

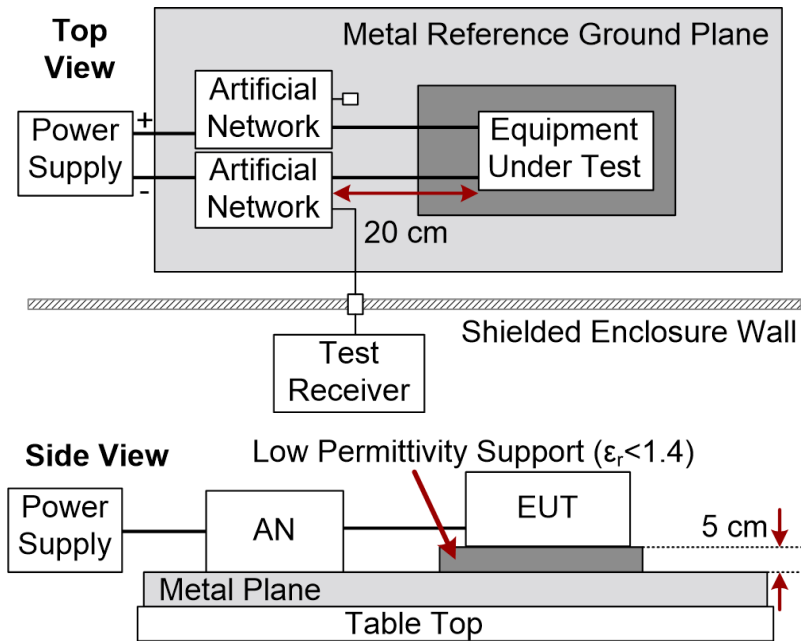

Radiated Emissions Setup

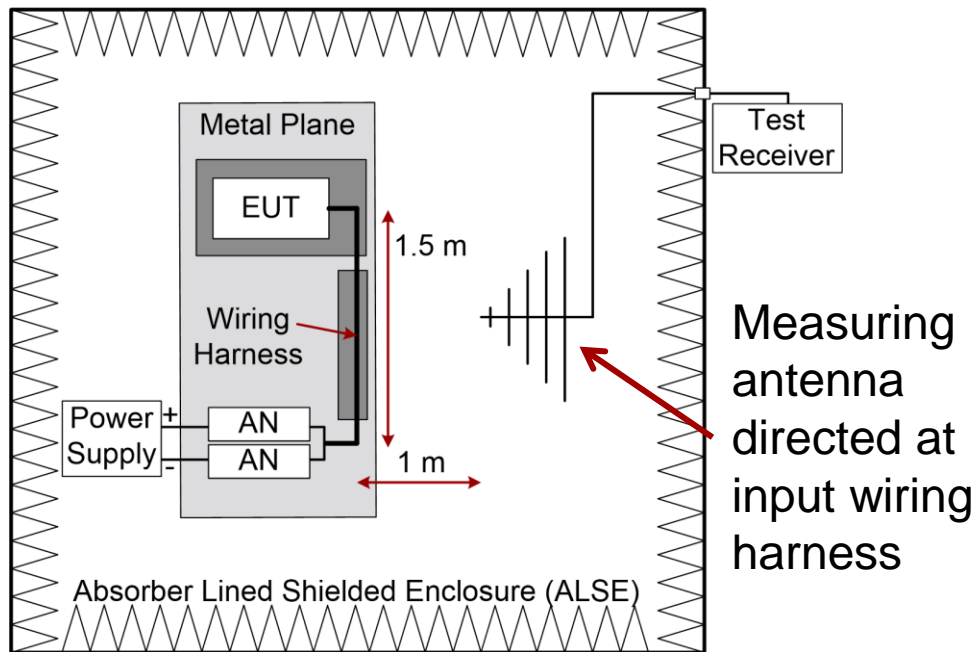

Address conducted emissions before testing radiated emissions

Conducted EMI test setup (CISPR 25)

- 2 artificial networks
- One terminated with $50\ \Omega$
 - One to receiver

Copper top table tied to back wall (grounded)

Load resistors

5 cm low permittivity support

Low noise lab source or car battery, connected to AN input

Equipment under test, 20 - 40 cm from ANs

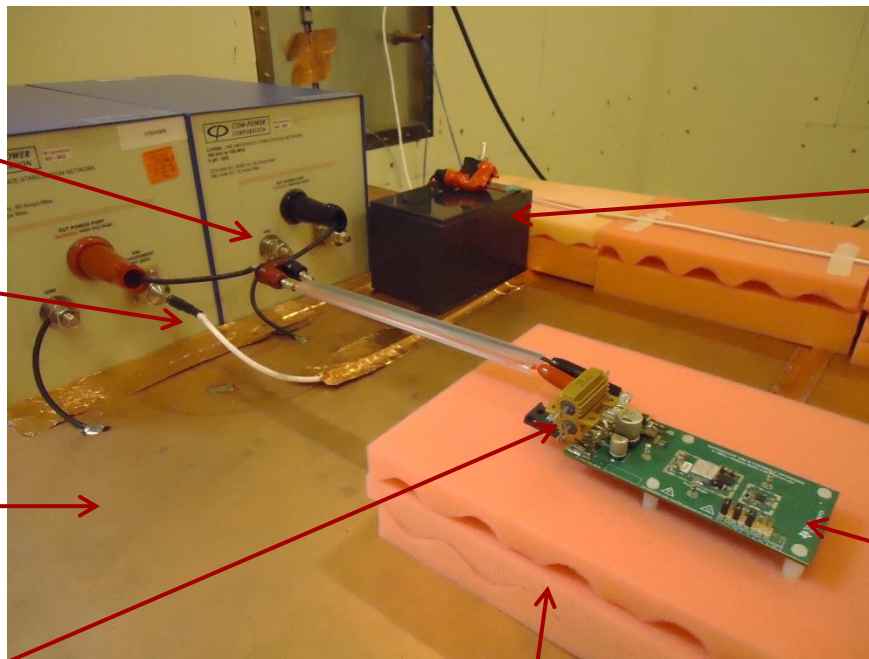

CISPR 32/22 conducted EMI test setup

- Equipment under test (EUT) placed on non-conductive table
- Horizontal & vertical ground planes
 - Or screened room
- EUT powered through line impedance stabilization network (LISN)
- Measure high-frequency (HF) emissions from LISN

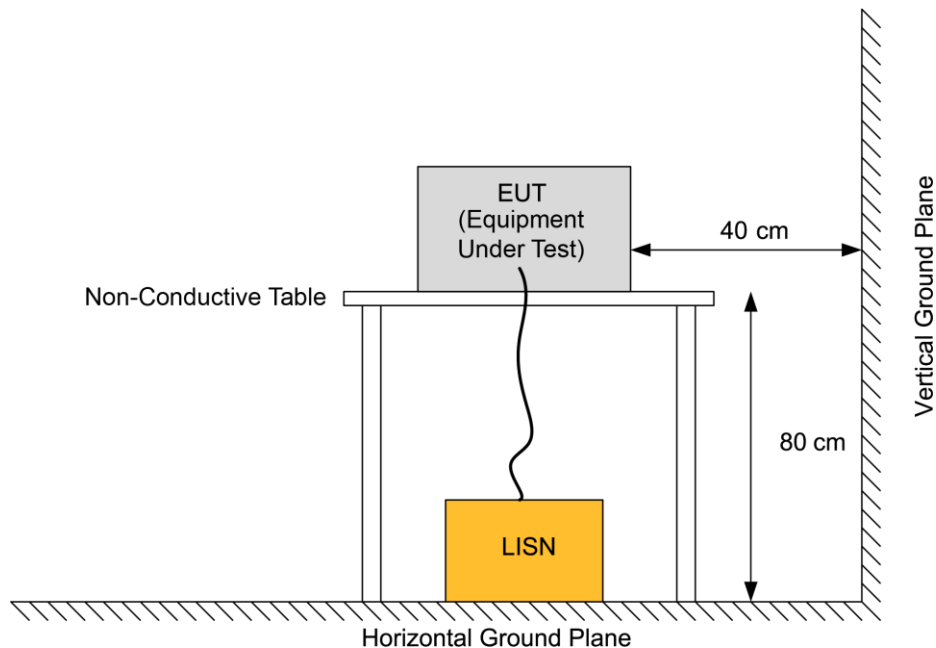

[1] EN55022, 2010, "Information technology equipment – Radio disturbance characteristics – Limits and methods of measurement"

TECHNIQUES FOR DEBUGGING EMI PROBLEMS

Brian King

DM or CM, Where to Begin?

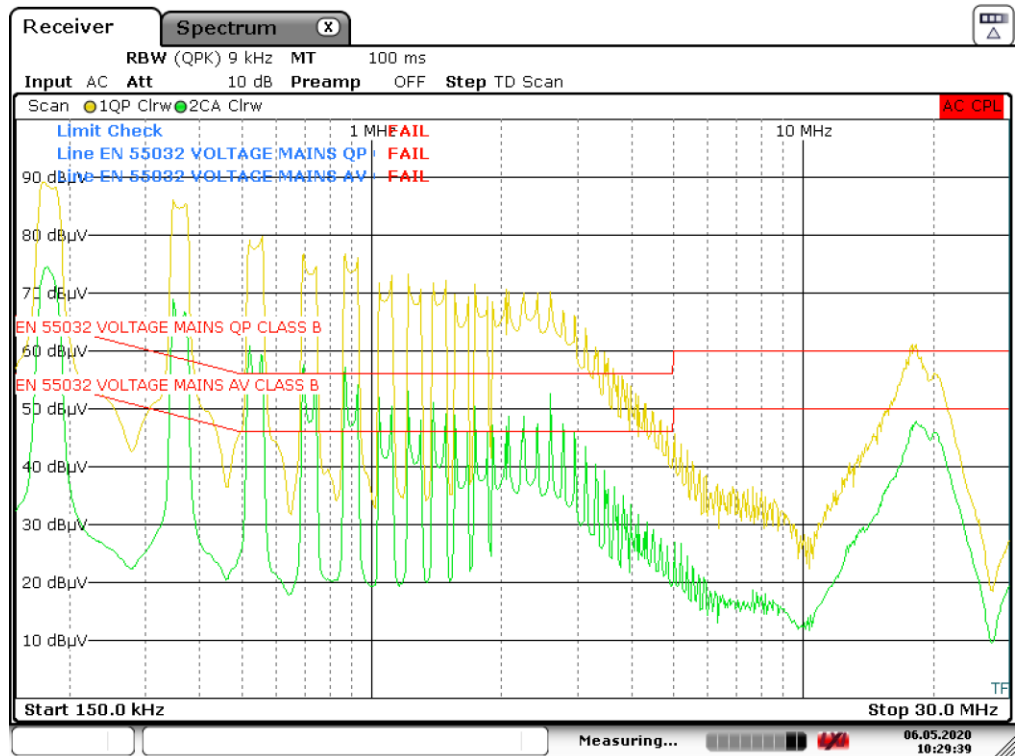

Date: 6.MAY.2020 10:29:39

Powerful EMI Weapons - Splitting CM and DM

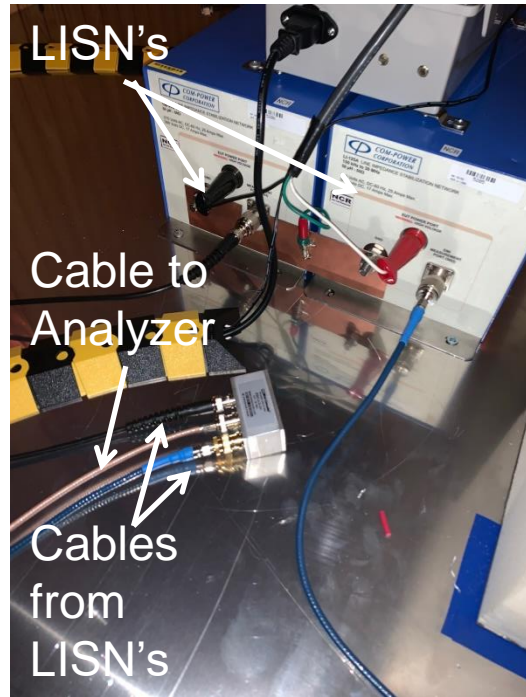

~\$60 on www.minicircuits.com
ZSC-2-2+ for DM mode
ZSCJ-2-2+ for CM mode

Bonus Tip: Can also tie PGND-SGND together to minimize CM signal

”Separation of common and differential mode conducted emission: Power combiner/splitters”
Andersen, Michael A. E.; Nielsen, Dennis; Thomsen, Ole Cornelius; Andersen, Michael A. E.
2012 Proceedings of the International Conference on Renewable Energies and Power Quality

Divide and Conquer Your EMI Enemies

Differential Mode

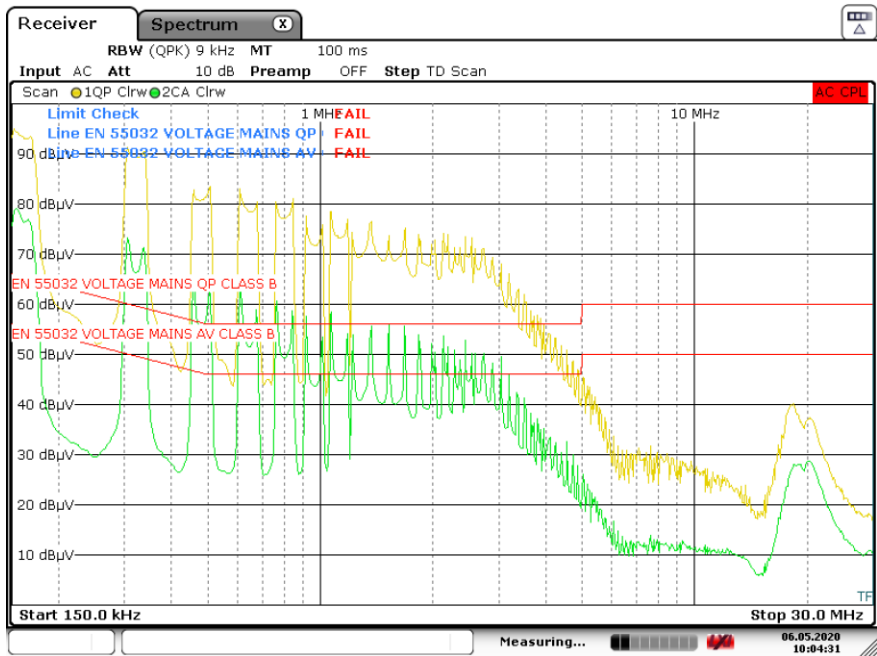

Common Mode

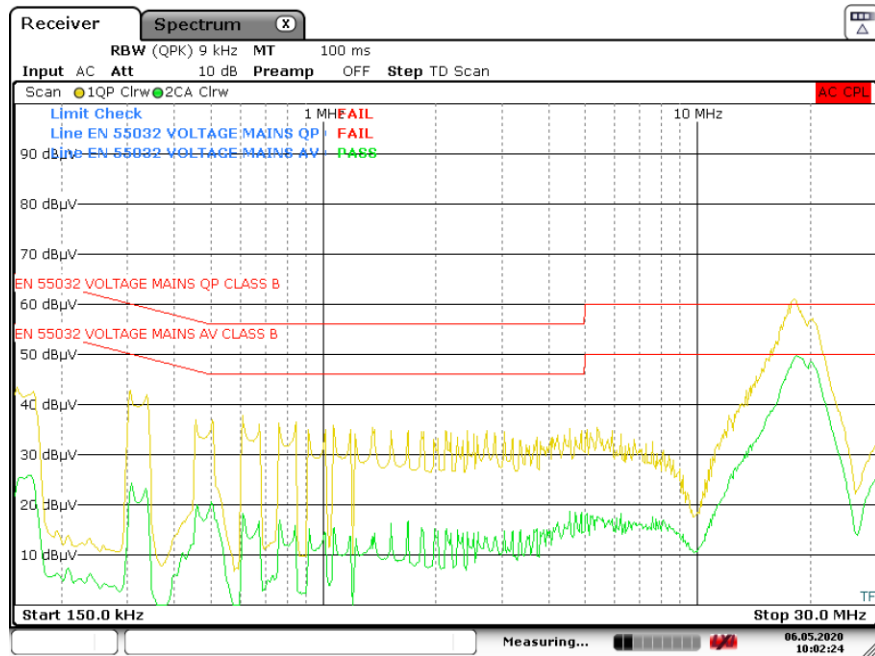

Date: 6.MAY.2020 10:04:31

Date: 6.MAY.2020 10:02:24

DM Battle Won!

Differential Mode

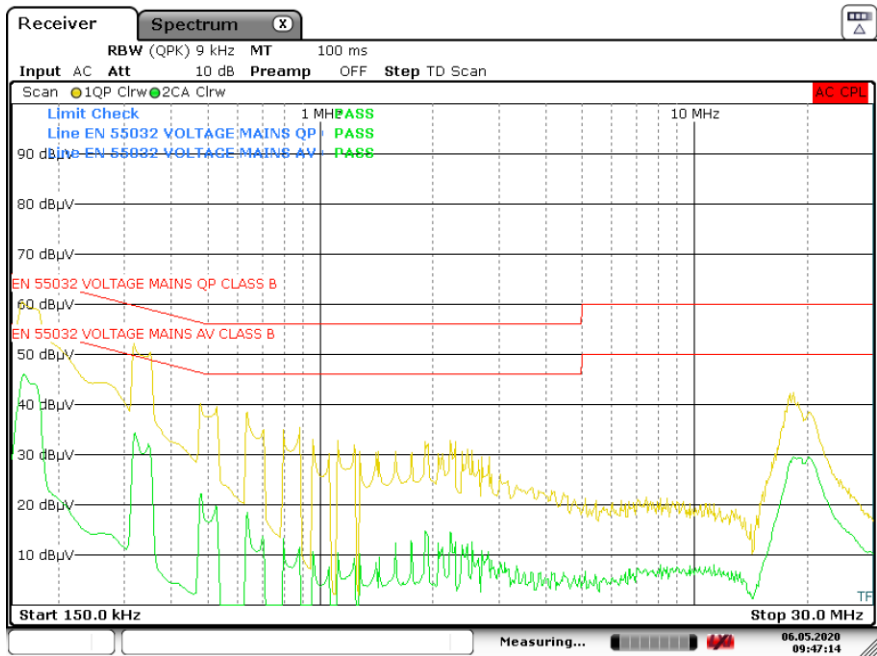

Common Mode

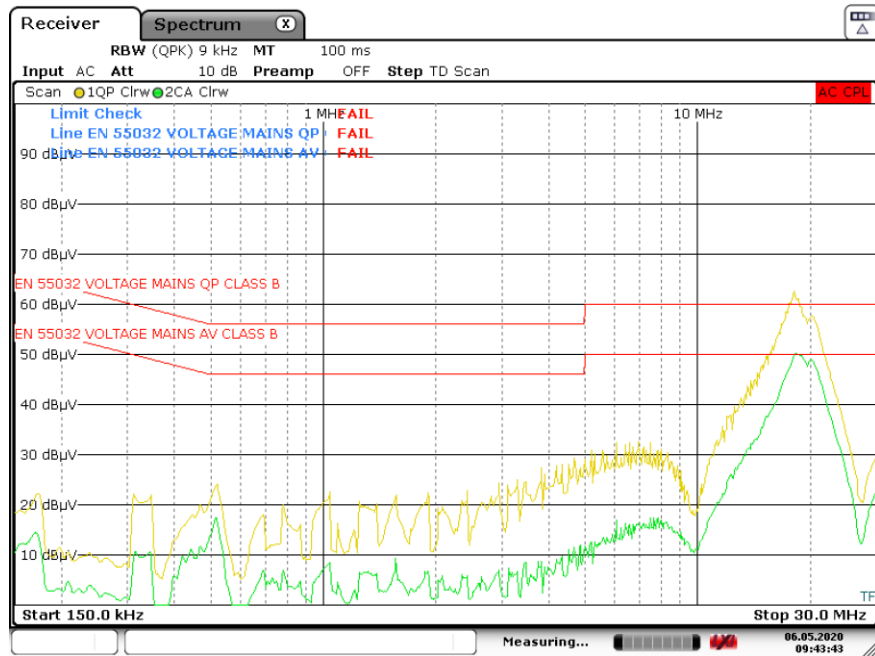

Date: 6.MAY.2020 09:47:14

Date: 6.MAY.2020 09:43:43

CM Battle Won!

Differential Mode

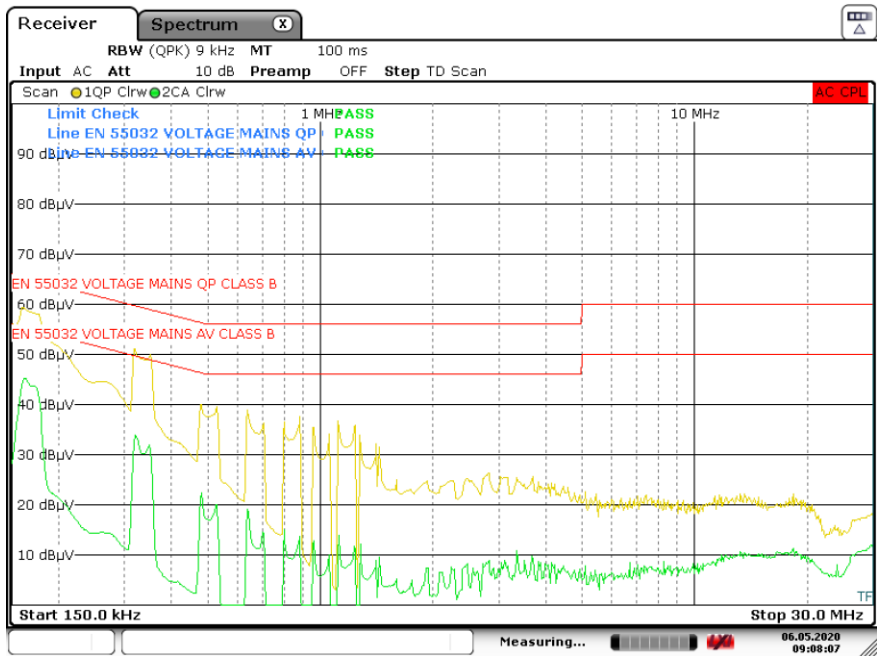

Common Mode

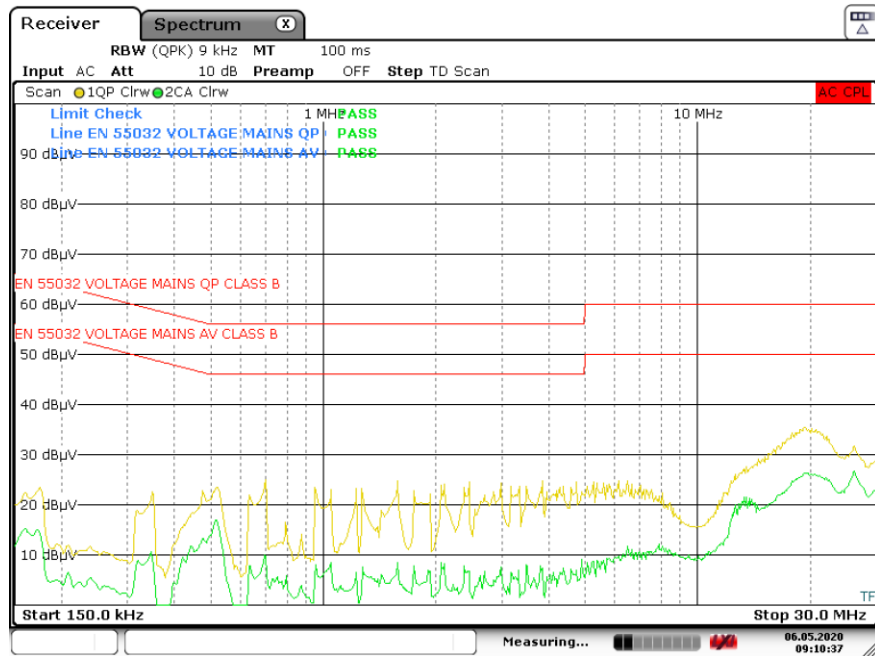

Date: 6.MAY.2020 09:08:07

Date: 6.MAY.2020 09:10:37

Total Victory!

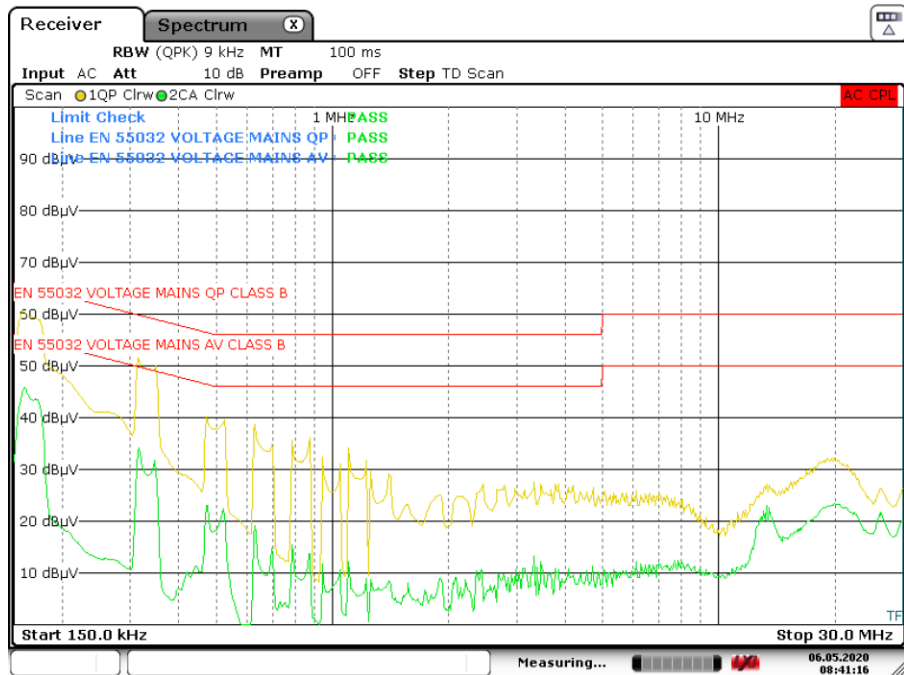

Date: 6.MAY.2020 08:41:16

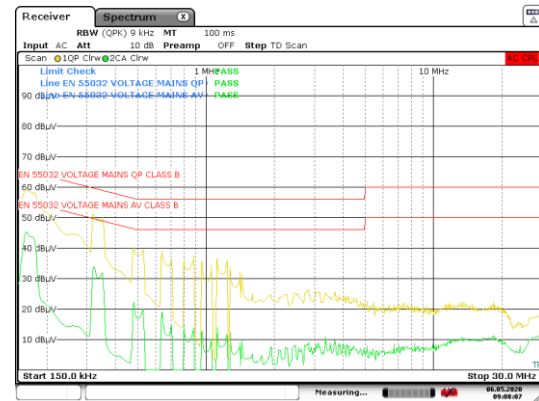

Date: 6.MAY.2020 09:10:07

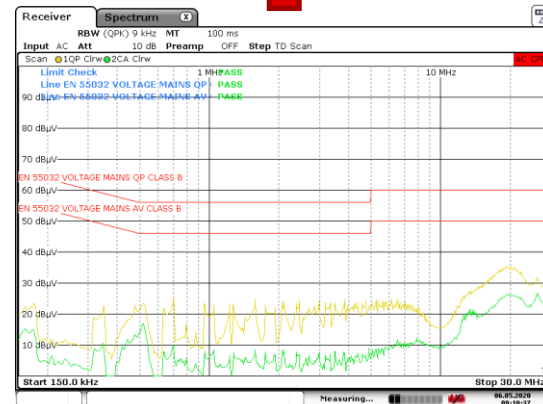

Date: 6.MAY.2020 09:10:37

20

DM filter choke practical considerations

- Choke requires high attenuation over wide bandwidth:
 - Load current amplitude typically several amps
 - At 50 dB μ V, current in LISN 50 Ω resistor only $\sim 6.3 \mu$ A
- Beware inductance roll-off with DC-bias
 - Must not saturate to be effective – needs high current rating
 - Consider the peak line current for non-PFC – high crest factor
- Switching power stage has fast changing magnetic fields
 - Beware filter bypassing & noise coupling
- Parasitic capacitance across DM inductor very important
 - Reduces effectiveness, especially at high frequency
- Example: To filter 300 kHz component, typically set LC freq. ~ 30 kHz
 - Expect ~ 40 dB attenuation at 300 kHz (double-pole $\Rightarrow 40$ dB/decade)
 - With parasitic cap \Rightarrow more like 30 dB attenuation only – even worse at higher frequency

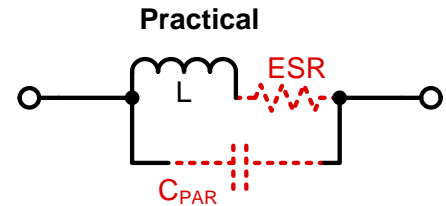
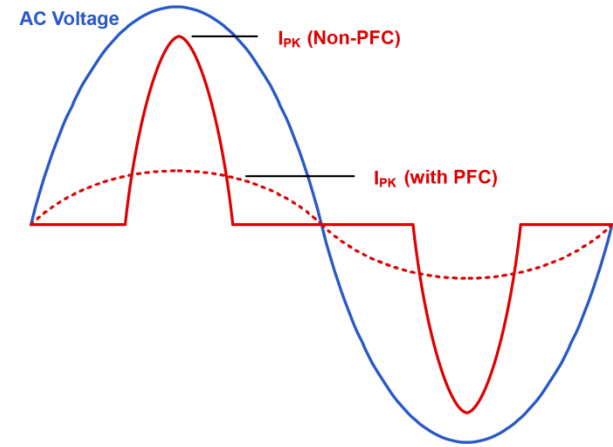

How is CM EMI generated?

- Switching voltage across parasitic capacitance causes CM current flow to EARTH
- CM noise also radiated to other circuit nodes

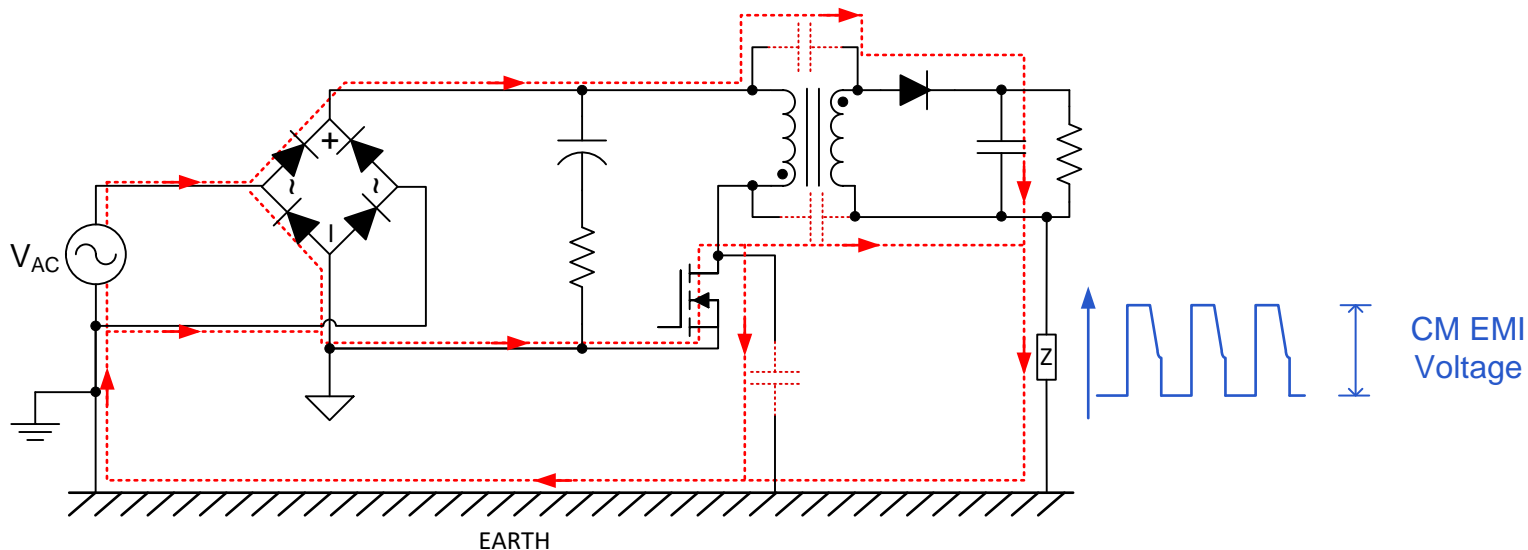

Transformer CM balance – PMP21479 ACF

- Add CM balance auxiliary layer (purple) in-between inner PRI (noisier) to SEC interface:
 - *Fill layer completely – acts as shield between PRI & SEC*
 - *Add turns to create CM balance, inject current to balance other PRI-SEC interface*

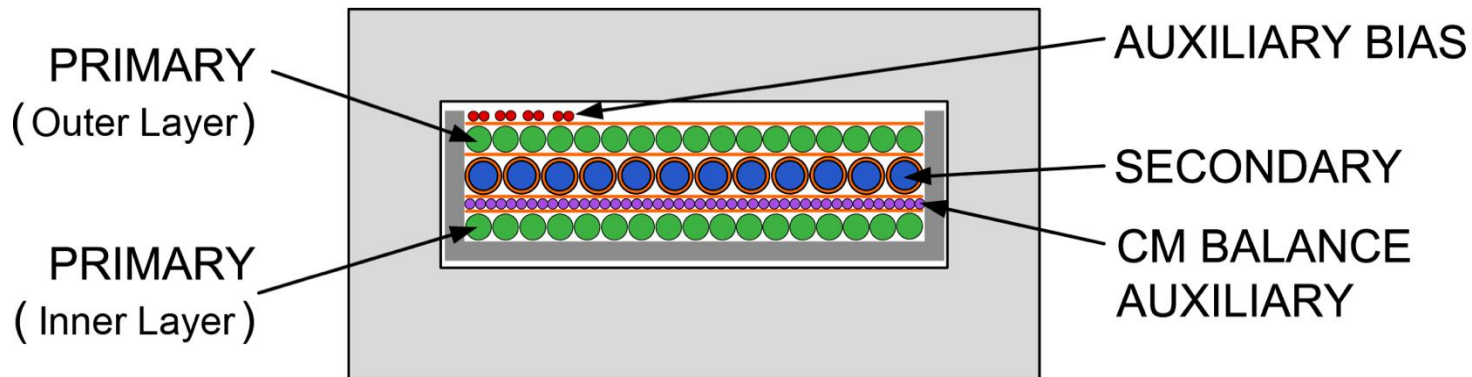

- NOTE: this example shows one way to add CM balance
- But there are many different ways to achieve the same CM result

Checking Transformer CM Balance

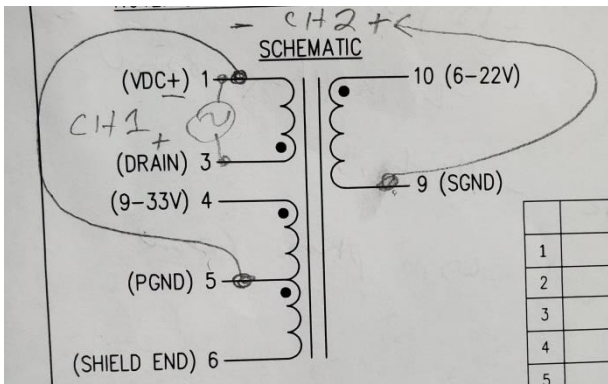

1. Tie primary AC quiet pins together.
2. Inject sinewave across main primary winding
3. Measure from secondary AC quiet node to primary AC quiet node

secondary-primary noise

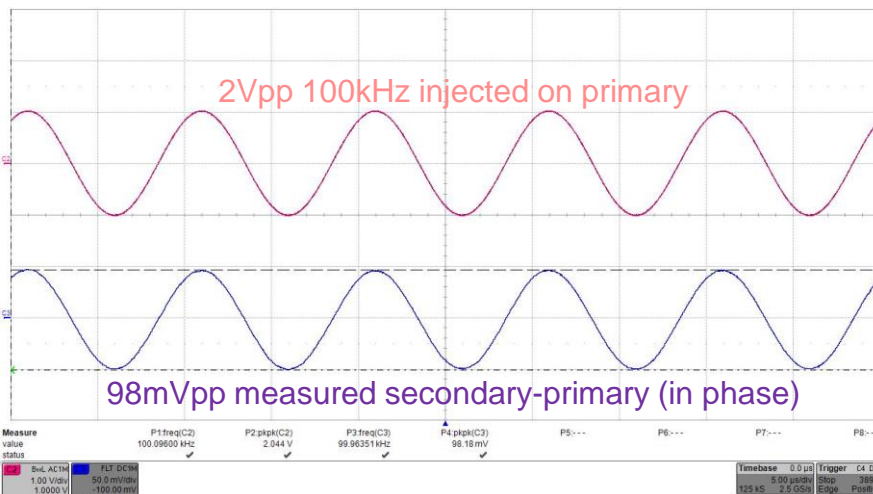
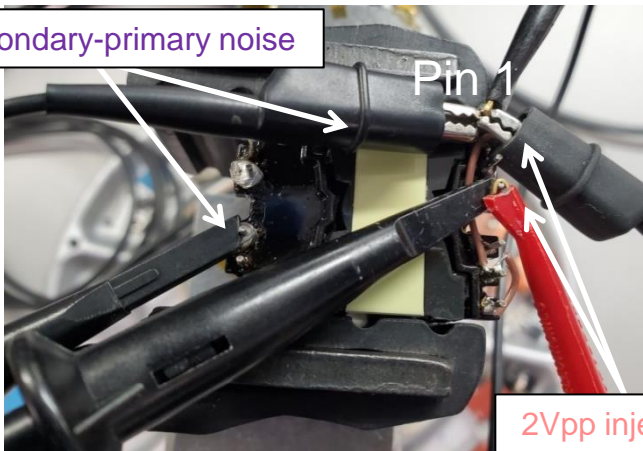

2Vpp injected on primary

Checking Transformer CM Balance

+2 Cancellation Turns

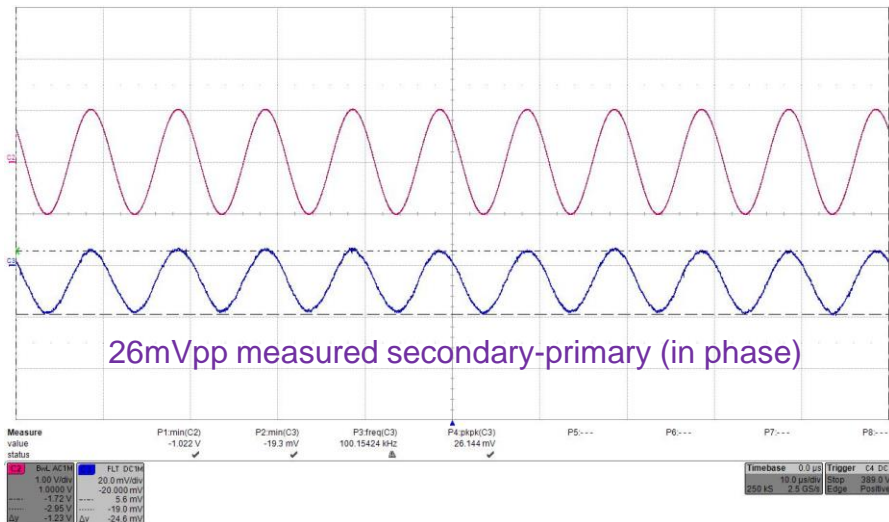

+3 Cancellation Turns

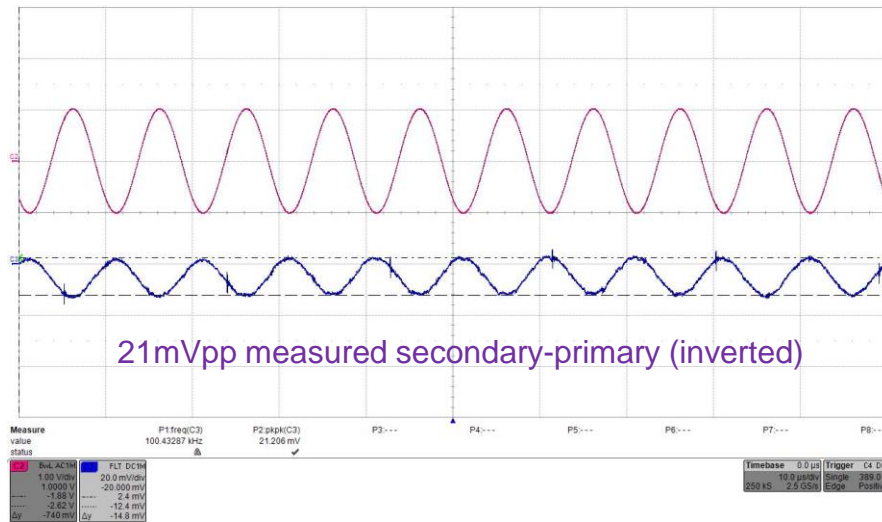

Observing the time-domain CM signal at the output

- Useful debug technique – ball-park indication of CM performance
 - Remove Y-cap temporarily (maximize signal)
 - Power EUT through LISN, with resistor loads
 - Wind several turns of wire around the load cables to create capacitive sensing coil (pickup coil)
 - Connect scope EARTH lead to LISN EARTH
 - Connect scope tip to sensing coil
 - Scope plot shows how much CM is coupled to output

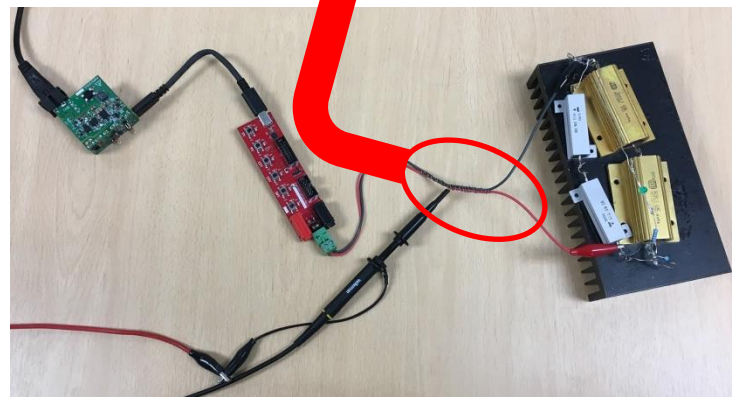
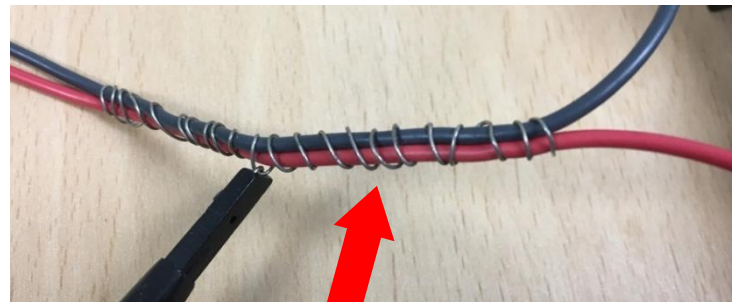
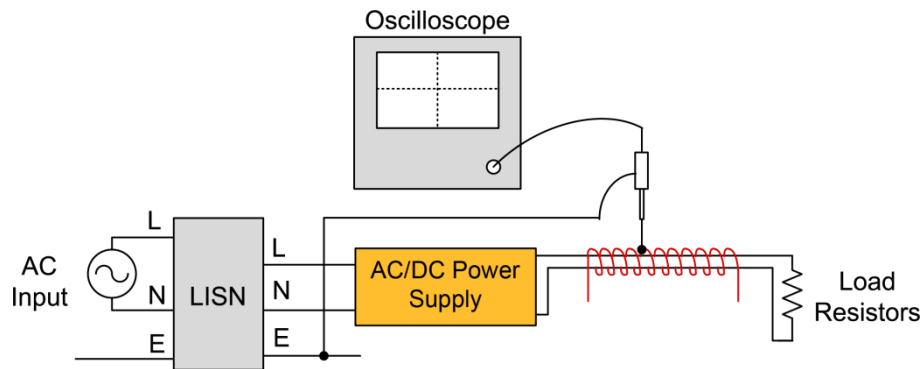

Interpretation of time-domain CM signal

- Will see “switch-node” shaped waveform – coupled to output
- Large PK-PK amplitude \Rightarrow bad CM noise
 - Will require significant CM filtering to suppress
 - Result from ACF example with 100 dB μ V EMI
- Small PK-PK amplitude \Rightarrow good CM noise
 - “Balanced” structure giving low CM
 - Will require much smaller CM filter
- Residual HF “spikes” \Rightarrow should only need small HF CM choke

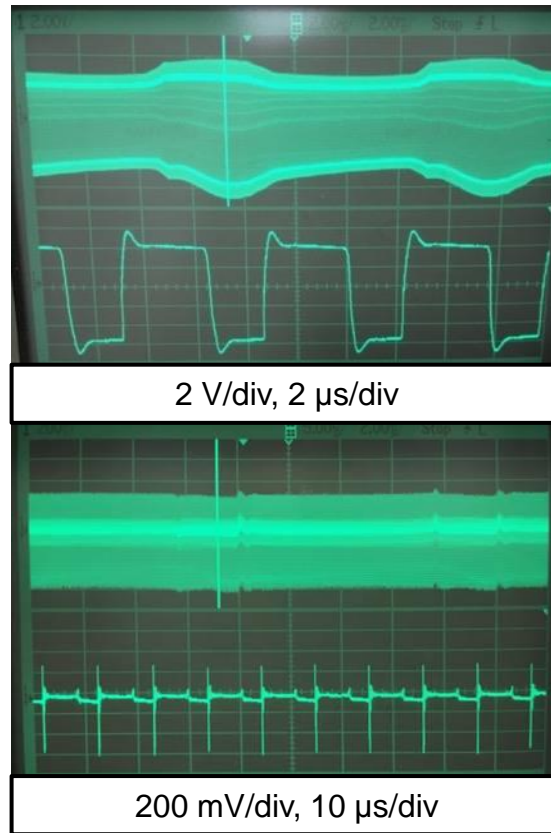

DESIGN EXAMPLE SHOWING PATH TO PASSING CISPR 25

Bob Sheehan

Design example

PMP21417/PMP21611 showing path to passing CISPR25.

- Automotive front end power solution for a high performance cluster
 - Three rails for point of load power
- PMP21417 designed and sent to customer
 - Our internal conducted emissions test looked good
 - Customer reported **failing radiated emissions**
- PMP21611 redesigned two of the rails
 - Our internal conducted emissions looked better
 - Customer reported **passing radiated emissions**

Architecture

PMP21417

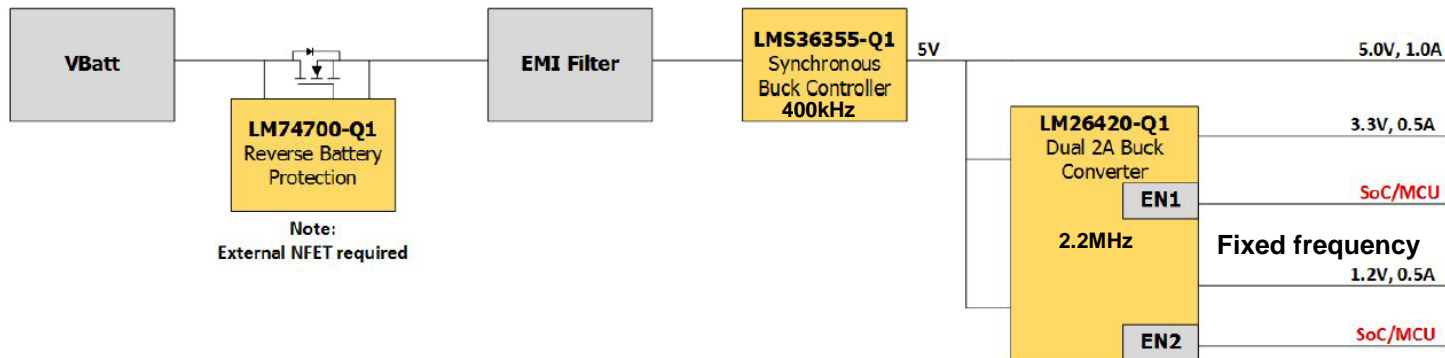

PMP21611 Better filtering + higher frequency switching

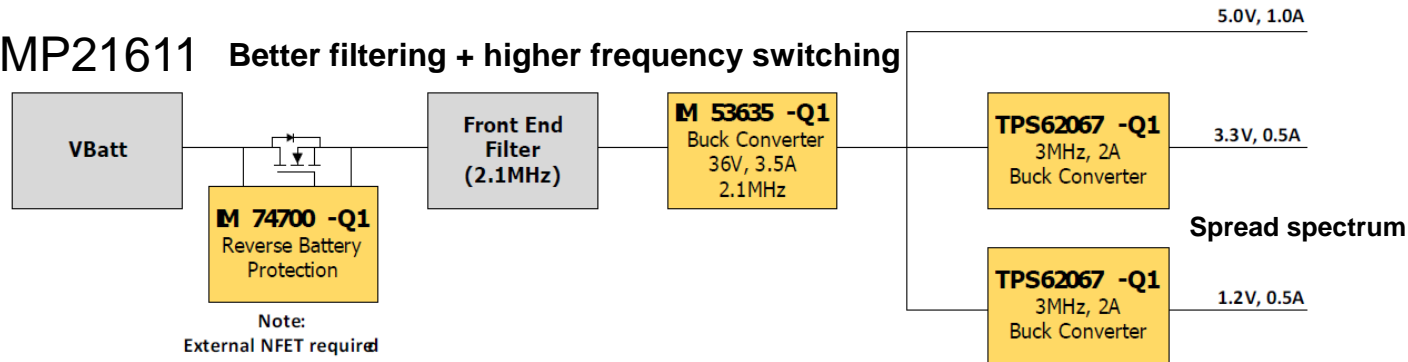

Reverse protection and filter

PMP21417

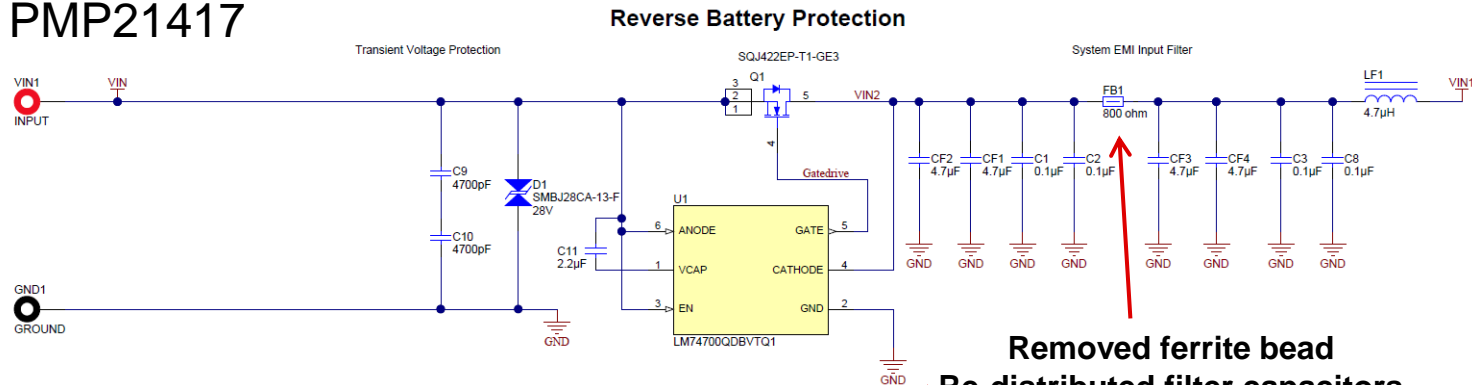

PMP21611

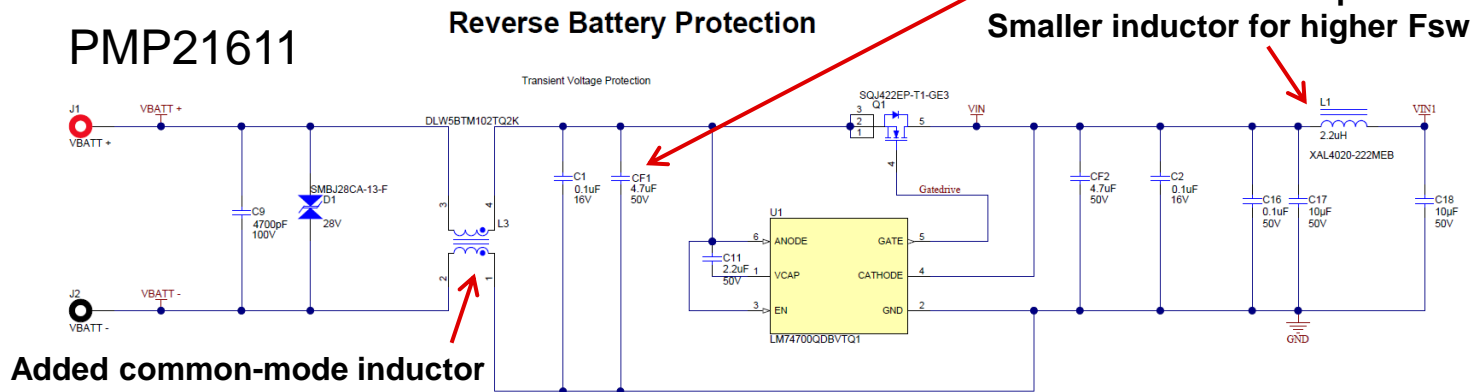

5 V system supply

PMP21417

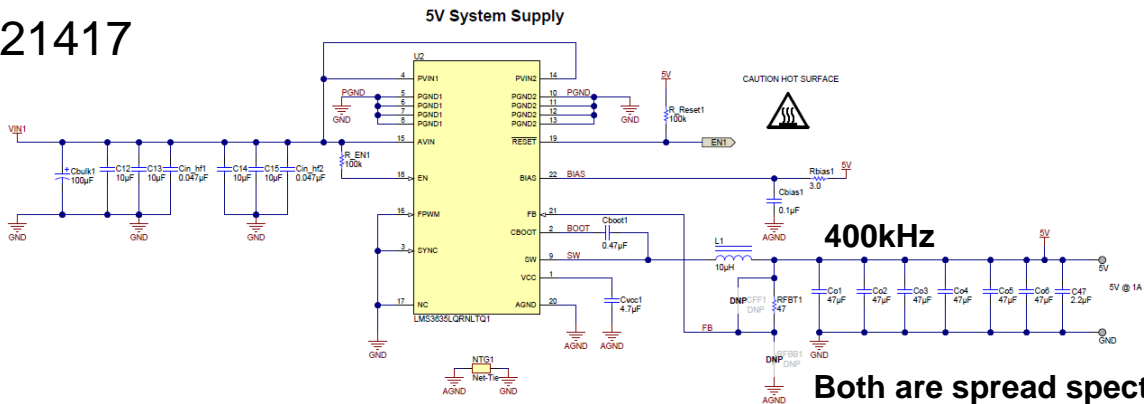

PMP21611

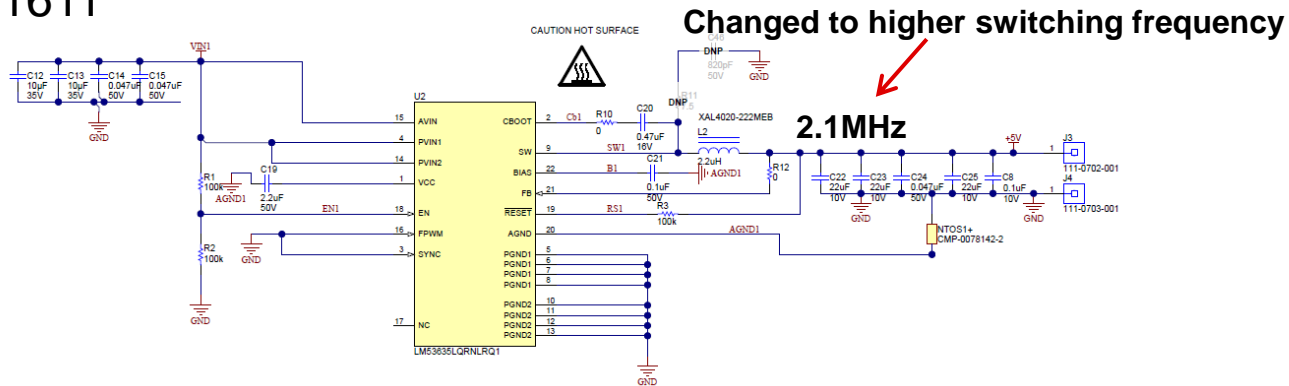

3.3 V and 1.2 V supplies

PMP21417

3.3V & 1.2V Supplies

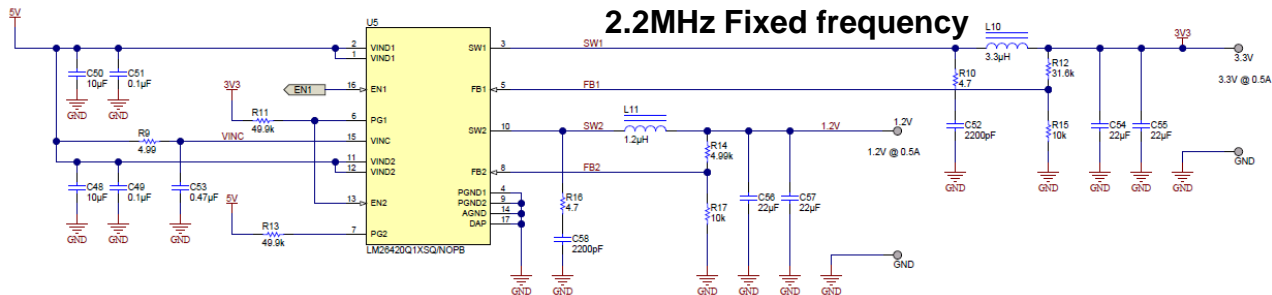

PMP21611

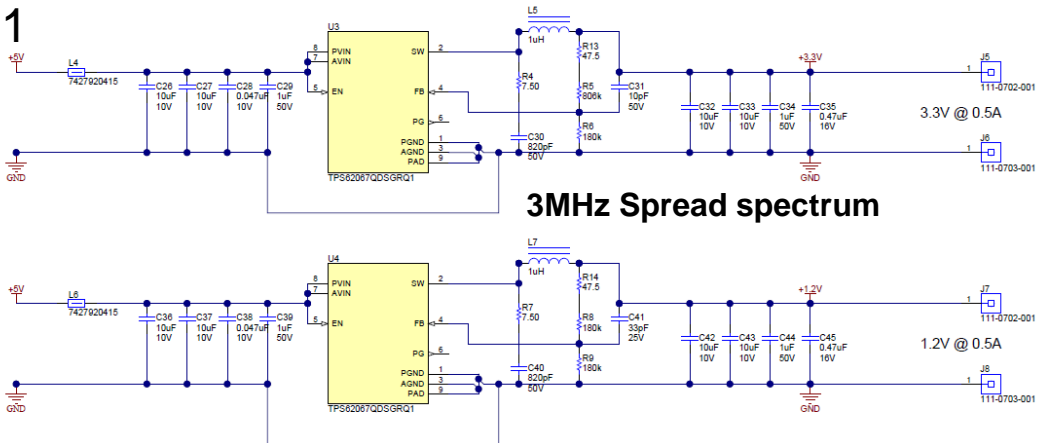

Top layer

PMP21417

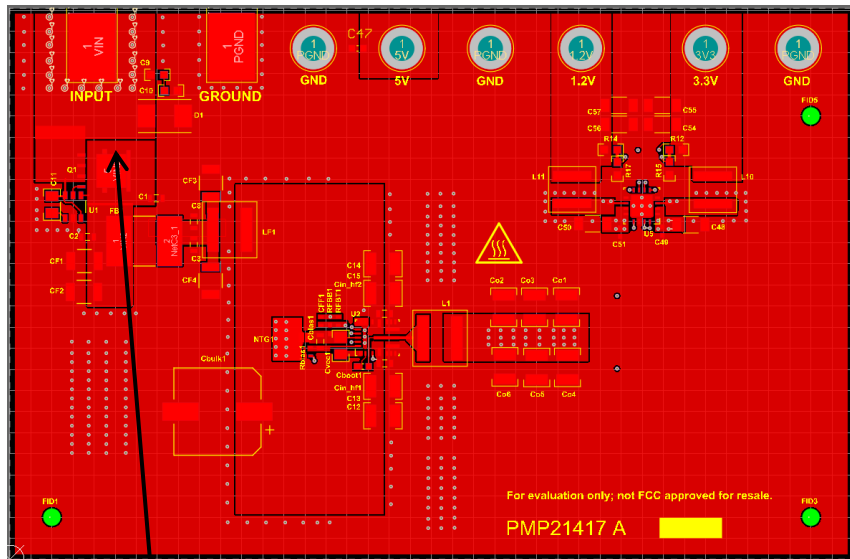

Moved input and filter to opposite edge of the board

PMP21611

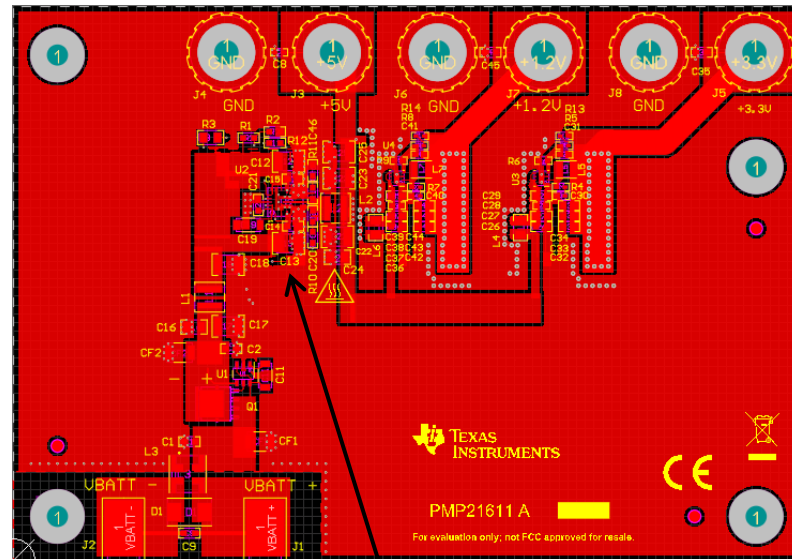

Ceramic caps feed 5V converter from both sides

Mid-layer 1

PMP21417

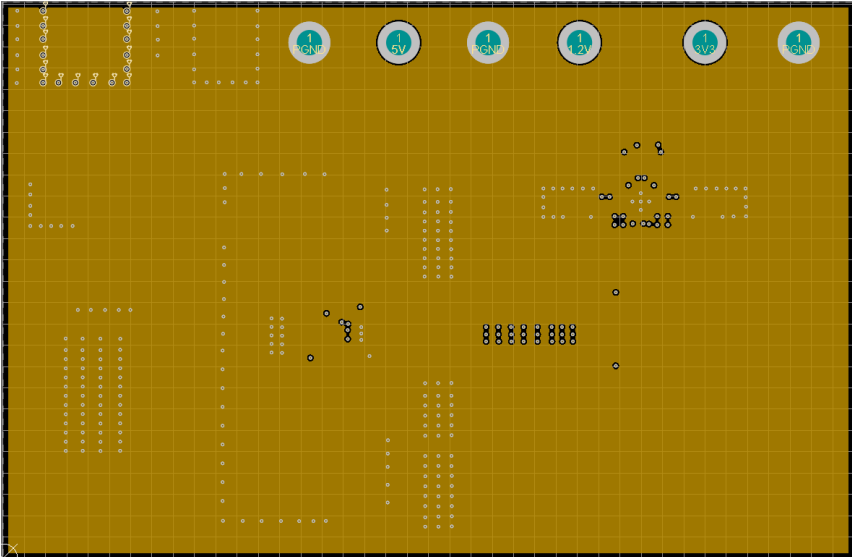

Input common-mode filter area kept clear

PMP21611

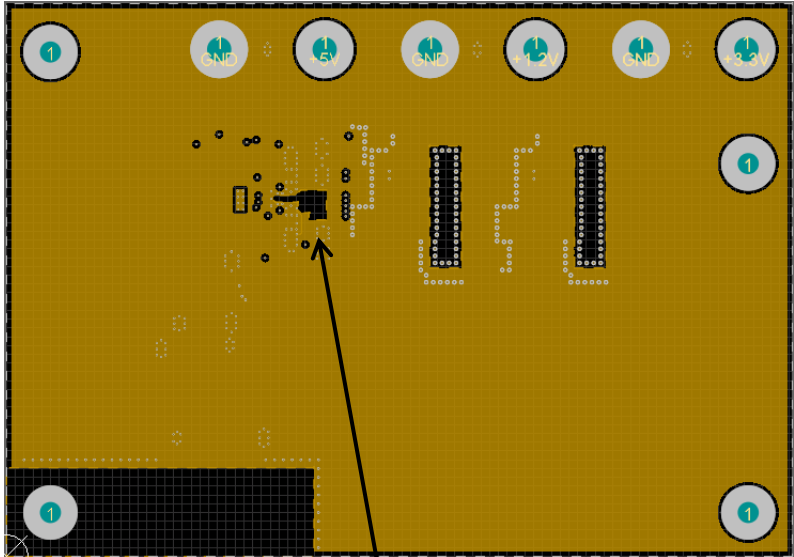

Removed copper under 5V inductor

Mid-layer 2

PMP21417

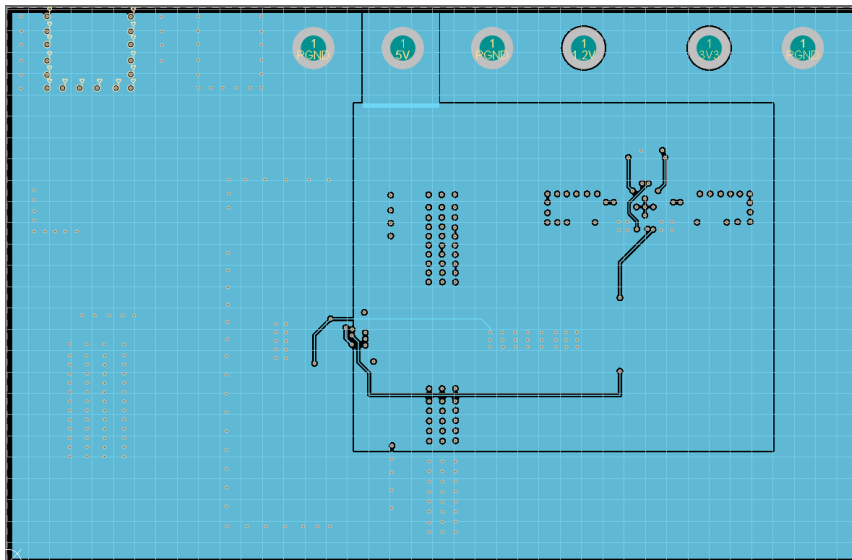

Input common-mode filter area kept clear

PMP21611

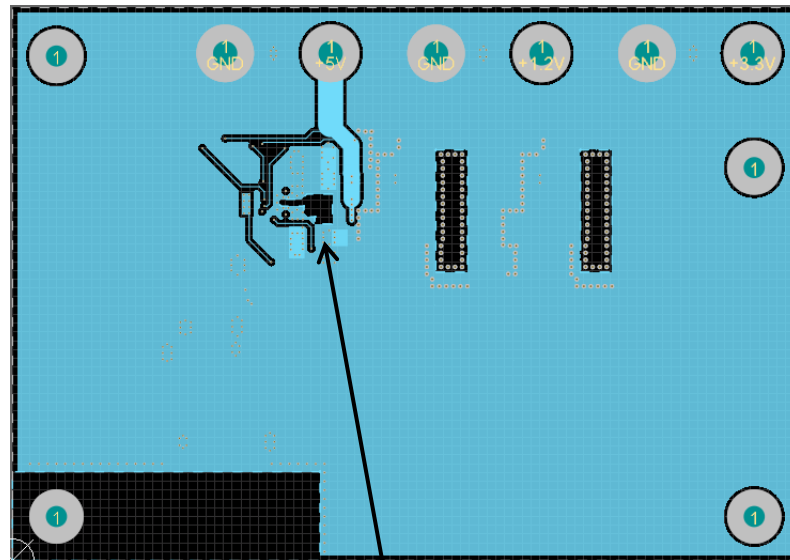

Removed copper under 5V inductor

Bottom layer

PMP21417

PMP21611

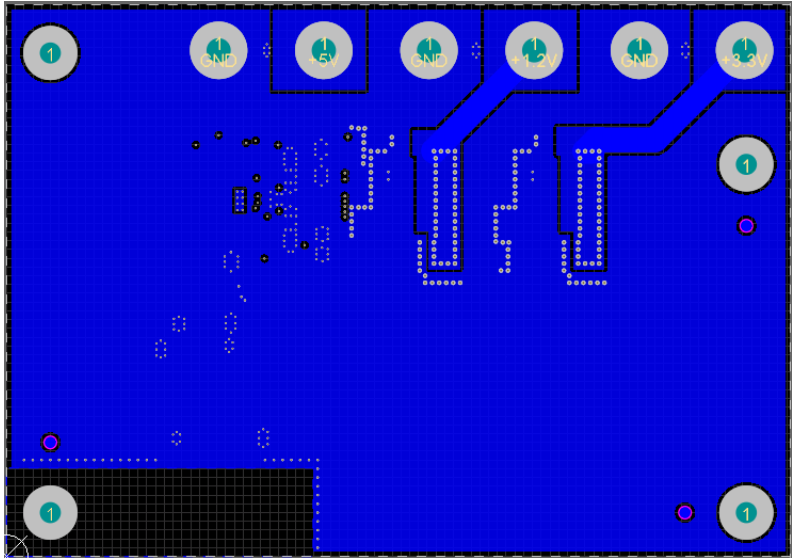
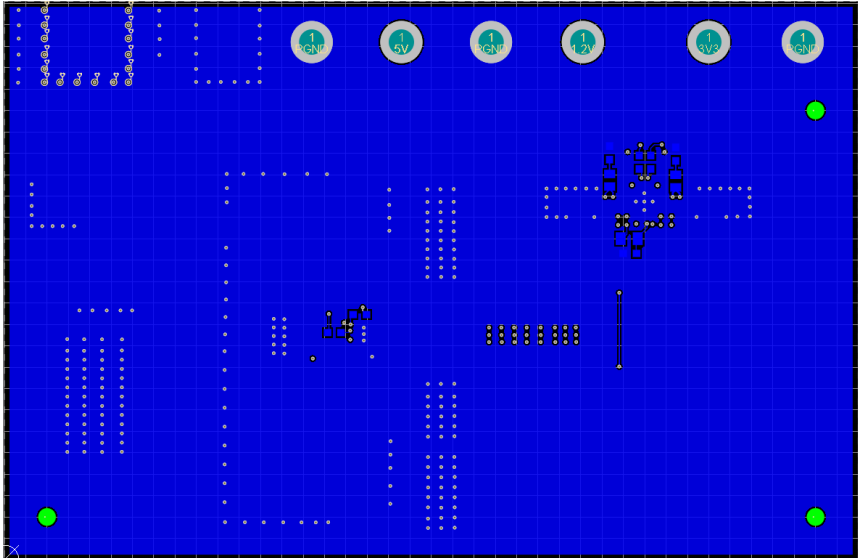

Input common-mode filter area kept clear



Conducted emissions – low frequency

PMP21417

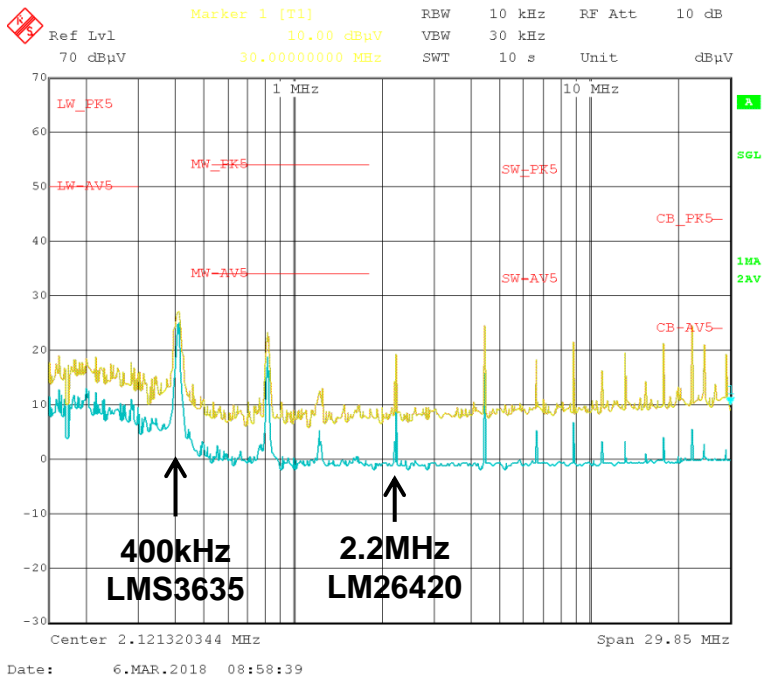

PMP21611

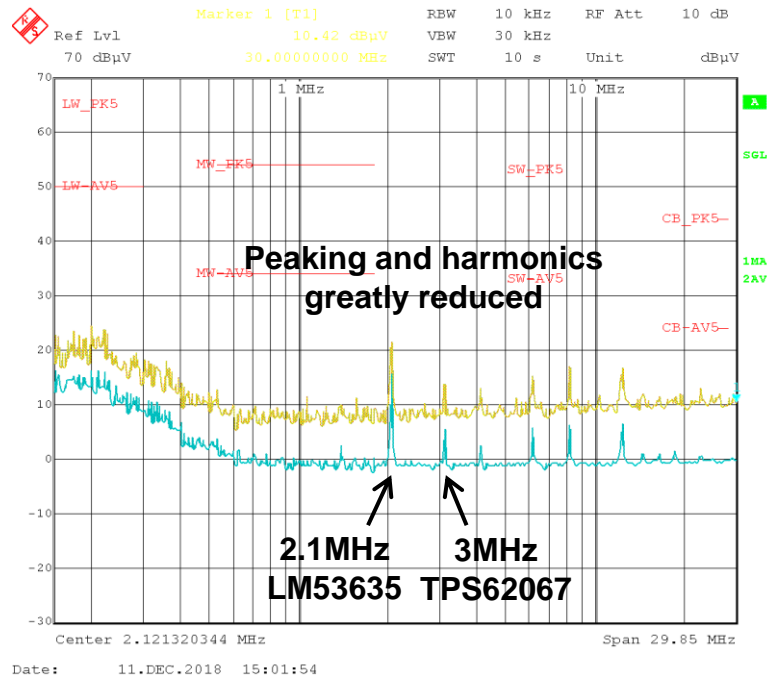

Conducted emissions – high frequency

PMP21417

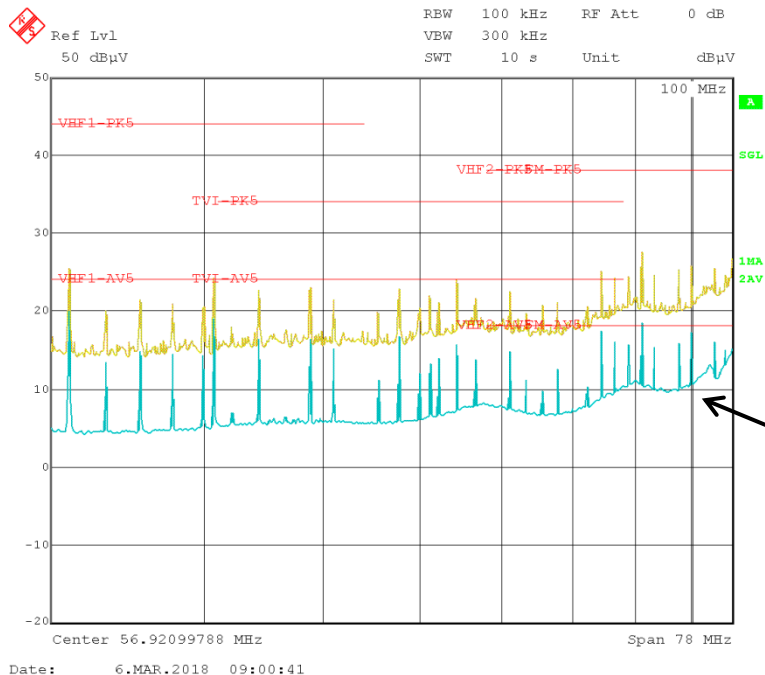

PMP21611

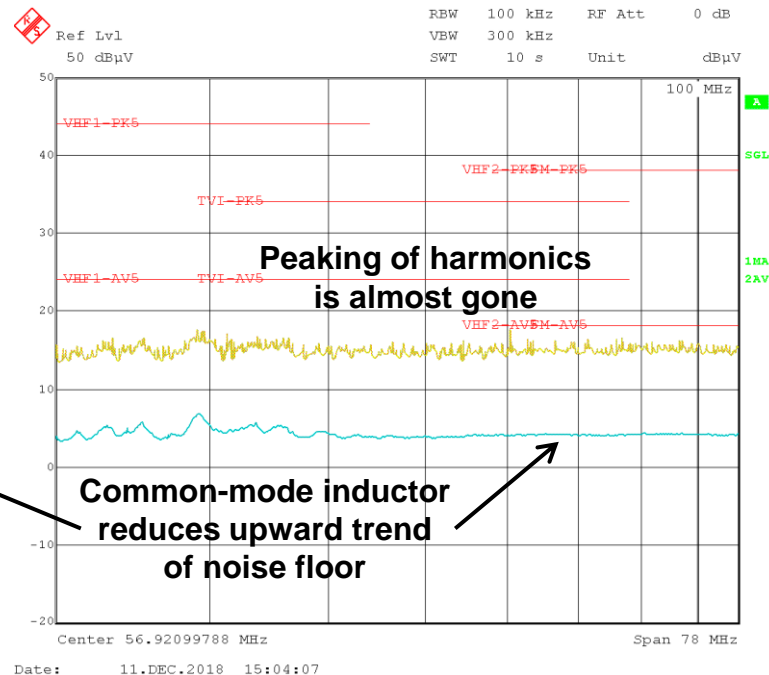

Common-mode inductor – low frequency

PMP21611 without CM inductor

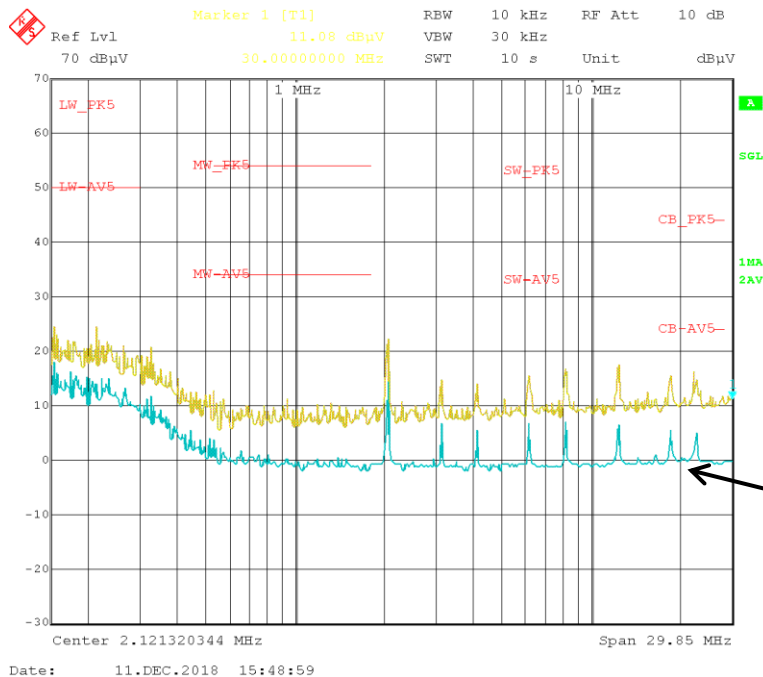

PMP21611 with CM inductor

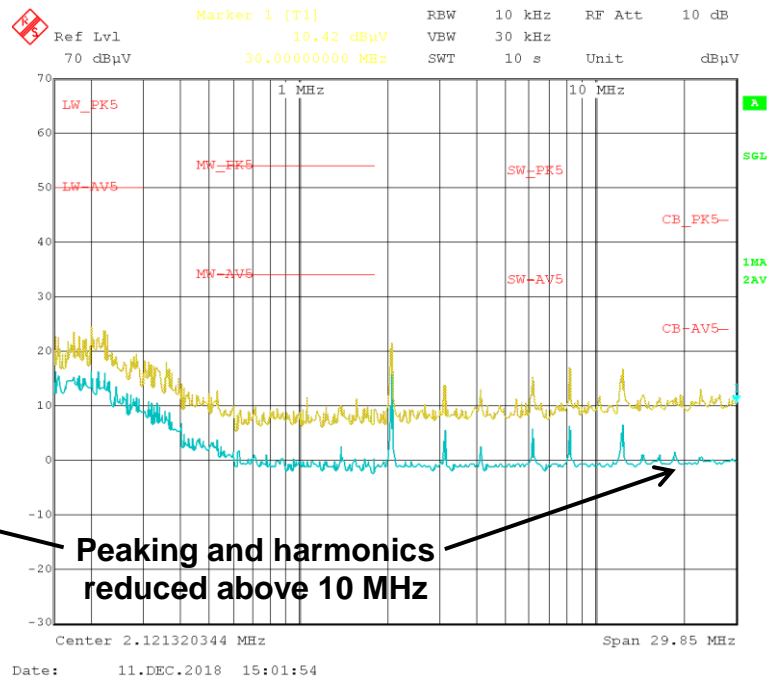

Common-mode inductor – high frequency

PMP21611 without CM inductor

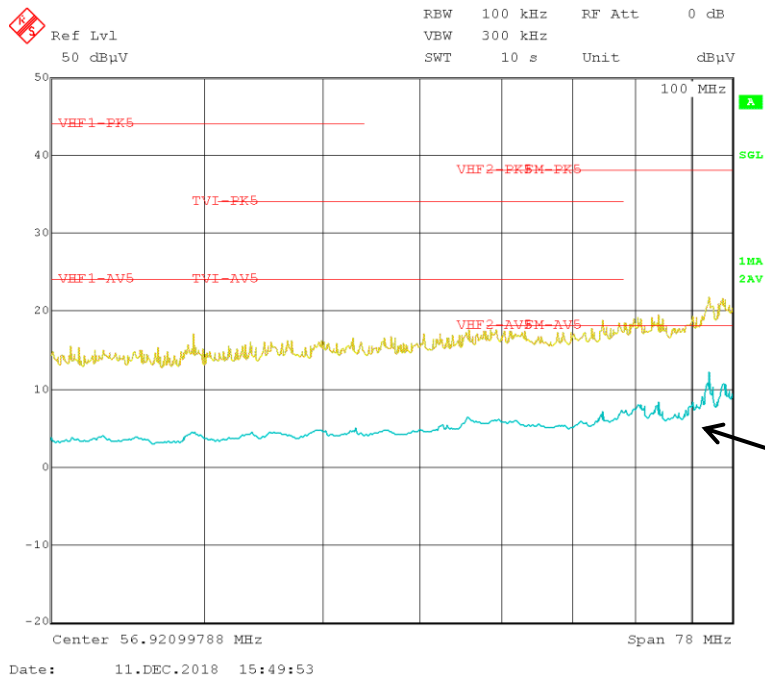

PMP21611 with CM inductor

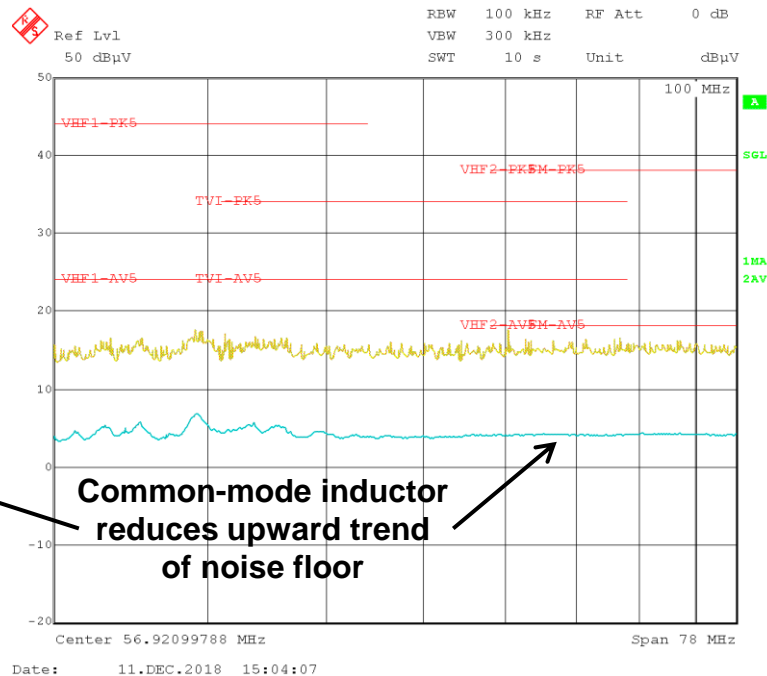

Common-mode inductor
reduces upward trend
of noise floor

Conclusion

- Designing power conversion systems to meet EMC requirements can be challenging.
- Understanding EMI sources, standards, filters, test setups is important
- Distinguishing between differential mode and common mode noise helps when debugging EMI problems and identifying solutions
- A path to meeting CISPR 25 requirements was demonstrated with a design example



©2020 Texas Instruments Incorporated. All rights reserved.

The material is provided strictly "as-is" for informational purposes only and without any warranty.
Use of this material is subject to TI's **Terms of Use**, viewable at [TI.com](https://www.ti.com)

IMPORTANT NOTICE AND DISCLAIMER

TI PROVIDES TECHNICAL AND RELIABILITY DATA (INCLUDING DATASHEETS), DESIGN RESOURCES (INCLUDING REFERENCE DESIGNS), APPLICATION OR OTHER DESIGN ADVICE, WEB TOOLS, SAFETY INFORMATION, AND OTHER RESOURCES "AS IS" AND WITH ALL FAULTS, AND DISCLAIMS ALL WARRANTIES, EXPRESS AND IMPLIED, INCLUDING WITHOUT LIMITATION ANY IMPLIED WARRANTIES OF MERCHANTABILITY, FITNESS FOR A PARTICULAR PURPOSE OR NON-INFRINGEMENT OF THIRD PARTY INTELLECTUAL PROPERTY RIGHTS.

These resources are intended for skilled developers designing with TI products. You are solely responsible for (1) selecting the appropriate TI products for your application, (2) designing, validating and testing your application, and (3) ensuring your application meets applicable standards, and any other safety, security, or other requirements. These resources are subject to change without notice. TI grants you permission to use these resources only for development of an application that uses the TI products described in the resource. Other reproduction and display of these resources is prohibited. No license is granted to any other TI intellectual property right or to any third party intellectual property right. TI disclaims responsibility for, and you will fully indemnify TI and its representatives against, any claims, damages, costs, losses, and liabilities arising out of your use of these resources.

TI's products are provided subject to TI's Terms of Sale (www.ti.com/legal/termsofsale.html) or other applicable terms available either on ti.com or provided in conjunction with such TI products. TI's provision of these resources does not expand or otherwise alter TI's applicable warranties or warranty disclaimers for TI products.

Mailing Address: Texas Instruments, Post Office Box 655303, Dallas, Texas 75265
Copyright © 2020, Texas Instruments Incorporated