

# The RS-485 unit load and maximum number of bus connections

By Kevin Gingerich (Email: k-gingerich@ti.com)

High-Performance Analog/Interface Products

## Introduction

TIA/EIA-485 (RS-485) is a popular electrical standard for data interchange over a multipoint differential bus. Multipoint buses are three or more stations connected to a common transmission medium that allow bidirectional data communication between any two nodes. Figure 1 schematically shows an example of a multipoint bus.

Maintaining a practical limit to the output-drive capability of an RS-485 driver requires that a limit be imposed on the steady-state load presented by the bus. This in turn constrains the input resistance of stations and, ultimately, the maximum number of connections.

RS-485 does not specify the maximum number of bus connections. Instead, the standard defines the steady-state electrical load presented by a bus connection in unit loads. The following paragraphs explain the unit load and how it is used to determine the maximum number of nodes connected to an RS-485 bus segment.

## The unit load

TIA/EIA-485-A defines a unit load as a 15-k $\Omega$  resistor connected to a -3- or 5-V source (see Figure 2). The -3-V case applies for positive input current, and the 5-V case applies for negative bus current. The definition and model are valid for input voltages from -7 to 12 V to account for driver outputs between 0 and 5 V, with up to  $\pm 7$  V of common-mode noise voltage between a driver and receiver.

Figure 2. Electrical model of 1 unit load

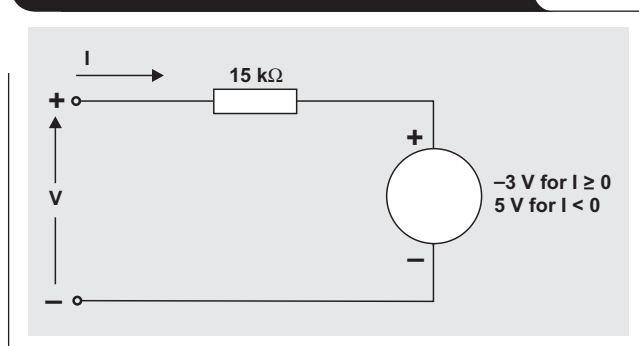
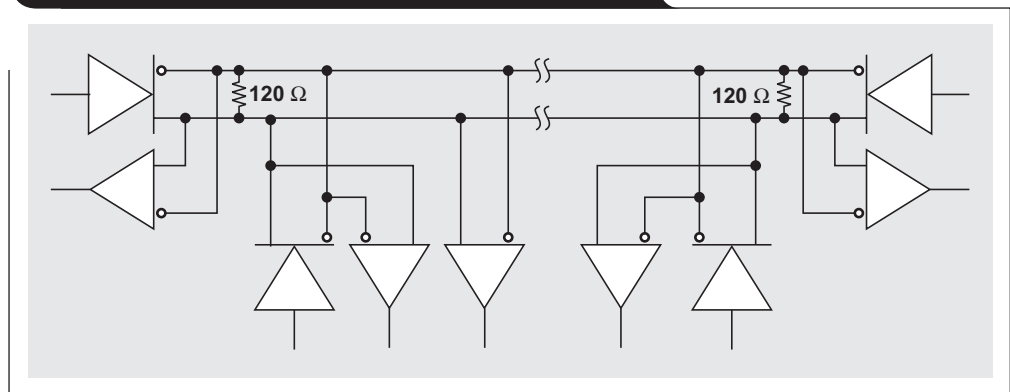

Figure 1. Schematic of an example multipoint bus



The number of unit loads (nUL) presented by any proposed connection to the RS-485 bus is then determined as the ratio of its measured input current and the current of 1 unit load. Since the current of 1 unit load is a function of voltage, the input current must be measured and the ratio determined throughout the entire -7- to 12-V input-voltage range, with the highest ratio determining the unit-load rating.

Figure 3 shows a hypothetical example where the measured input current of a circuit is nonlinear. It can be shown (see sidebar on next page) that, at its maximum value, the ratio of the measured and unit-load current is equal to the ratio of the slopes of the two functions and lies on a line with an intercept at -3 V for positive current and 5 V for negative current. Conceptually, this amounts to rotating a line pivoted at  $I = 0$  mA and  $V = -3$  V until it is tangent to the curve of measured positive current versus

Figure 3. Example unit-load analysis

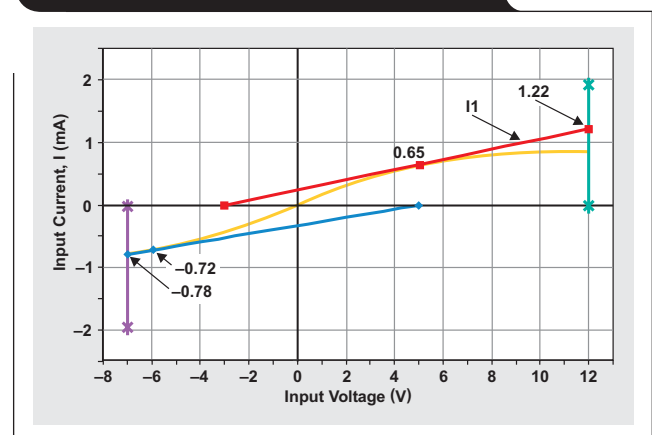

**Proof that nUL is the slope ratios**

Let the input current of a unit load be defined by  $f_1(V)$  and the measured circuit by  $f_2(V)$ . The number of unit loads (nUL) is then

$$nUL = \frac{f_2(V)}{f_1(V)}$$

for  $-7\text{ V} < V < 12\text{ V}$ .

The maximum nUL occurs when the first derivative equals zero, or

$$\frac{d}{dV} \frac{f_2(V)}{f_1(V)} = \frac{1}{f_1(V)} \frac{d}{dV} f_2(V) - \frac{f_2(V)}{f_1^2(V)} \frac{d}{dV} f_1(V) = 0.$$

$$\frac{d}{dV} f_2(V) = \frac{f_2(V)}{f_1(V)} \frac{d}{dV} f_1(V).$$

$$\frac{f_2(V)}{f_1(V)} = \frac{\frac{d}{dV} f_2(V)}{\frac{d}{dV} f_1(V)}. \quad (1)$$

Therefore, the maximum nUL is equal to the ratio of the first derivative (slopes) of the input-current function.

The following equations are used to solve for the unit-load circuit:

$$f_1(V) = \frac{V+3}{15} \text{ mA or}$$

$$f_1(V) = \frac{V-5}{15} \text{ mA and } \frac{d}{dV} f_1(V) = \frac{1}{15} \text{ mho.}$$

Substituting these into Equation 1 yields

$$\frac{f_2(V)}{\frac{V+3}{15}} = \frac{\frac{d}{dV} f_2(V)}{\frac{1}{15}}$$

$$f_2(V) = \frac{d}{dV} f_2(V) \times (V+3)$$

or

$$\frac{f_2(V)}{\frac{V-5}{15}} = \frac{\frac{d}{dV} f_2(V)}{\frac{1}{15}}$$

$$f_2(V) = \frac{d}{dV} f_2(V) \times (V-5).$$

These line equations mean that the input current where the nUL is maximum lies on a line that intersects the points  $I = 0\text{ mA}$  and  $V = -3\text{ V}$  for positive current and  $I = 0\text{ mA}$  and  $V = 5\text{ V}$  for negative current.

voltage. For negative currents, the line is pivoted at  $I = 0\text{ mA}$  and  $V = 5\text{ V}$ . In our example, the maximum ratio occurs at measured input currents of  $0.65\text{ mA}$  and  $-0.72\text{ mA}$ .

The ratio and nUL may be calculated by dividing the measured value at the intercept by the value derived from solving the unit-load circuit; or, for convenience, the lines are often extended to the  $12\text{-}$  or  $-7\text{-V}$  intercept. Since the slopes for 1 unit load and the tangential lines are constants, their ratios are constant and may be determined at any voltage. By definition, the current into 1 unit load at  $12\text{ V}$  will be  $1\text{ mA}$ , and at  $-7\text{ V}$  will be  $-0.8\text{ mA}$ . These values are respectively divided into the current-intercept values of the tangential lines at  $12\text{ V}$  and  $-7\text{ V}$ , and the maximum number determines the nUL for the circuit. In the example, the input-current-versus-voltage characteristics of the hypothetical circuit result in  $1.22$  unit loads.

**Maximum unit loads**

The minimum output-drive capability of a standard RS-485 driver is established in clause 4.2.3 of TIA/EIA-485-A, which specifies a differential output voltage of at least  $1.5\text{ V}$  with a common-mode load. Figure 4 shows a schematic of this test circuit.

**Figure 4. Differential output voltages with a common-mode load**

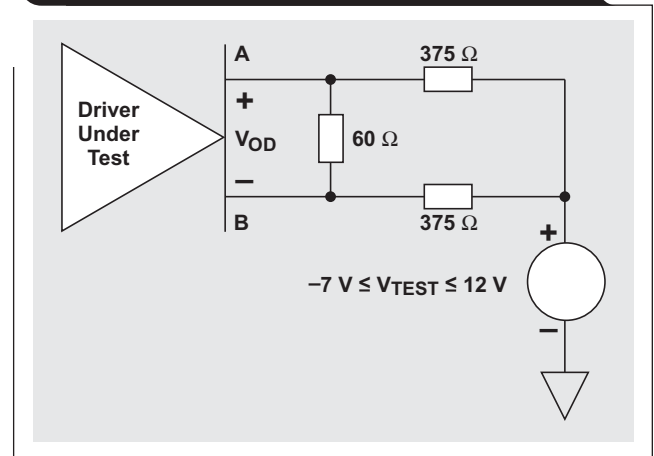

The  $375\text{-}\Omega$  resistors are certainly part of the common-mode load. What is not obvious is that the test voltage of  $-7$  to  $12\text{ V}$  actually represents a  $\pm 7\text{-V}$  common-mode noise source and a  $0$ - to  $5\text{-V}$  local supply voltage at the load(s). This is important in that the local supply is included in the unit-load determination for this test circuit. Figure 5 shows the common-mode test circuit with the insertion of a “local” ground used as the reference for the unit-load calculation.

To determine the unit load of this test circuit, we plot the input-current-versus-voltage function between point A or B and the “local” ground of Figure 5, then apply the unit-load definition described earlier. This is done in Figure 6, and we find that the current at the intercepts of the tangential lines is  $32\text{ mA}$  at  $V = 12\text{ V}$ , and  $-32\text{ mA}$  at  $V = -7\text{ V}$ . By definition, this represents  $32$  unit loads and  $40$  unit loads, respectively.

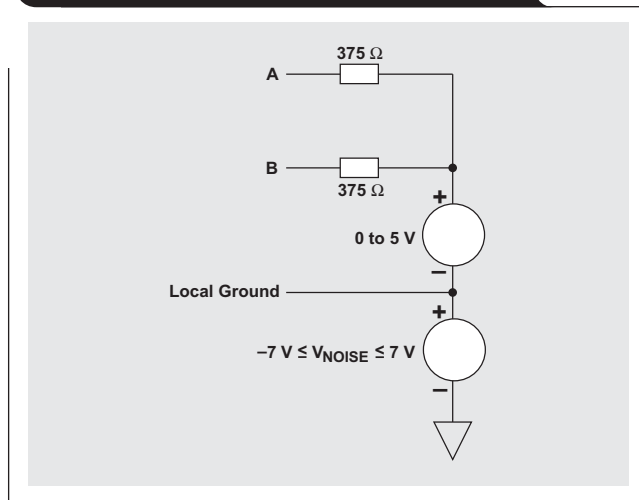
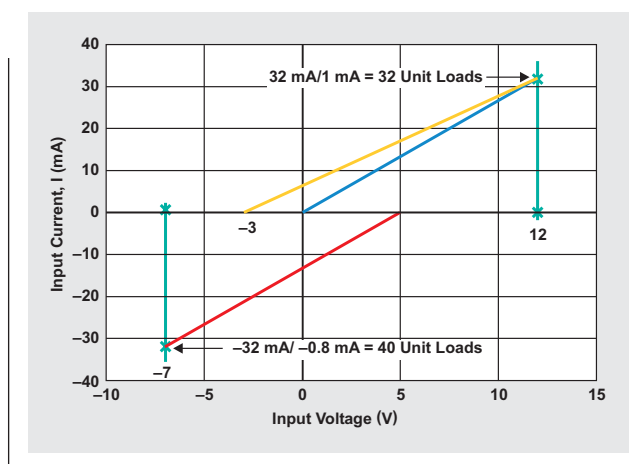
**Figure 5. Physical representation of the test circuit****Figure 6. Unit load of common-mode test circuit**

The reader may have noted the discrepancy between the unit-load model and the driver test circuit. One can only assume that this was an oversight or compromise by the authors of TIA/EIA-485. As tested, the unit-load model should consist of a 12-k $\Omega$  resistor to a 0- to 5-V source rather than 15 k $\Omega$  to a -3- to 5-V source. If we use this modified definition, the differential output voltage with common-mode load test of TIA/EIA-485-A ensures that a standard driver will work with 32 unit loads.

### Using the unit load

Other than a refresher on analytic geometry, of what use is the unit-load concept to the designer of a data-interchange circuit? Primarily, it provides a single standard parameter for calculating the maximum number of connections and for specifying the input characteristics of possible line circuits. Since we know a driver will support 32 unit loads in a standard bus configuration, we need only divide 32 by the total number of nodes (N) to derive the maximum

unit-load rating for each of the line circuits. For example, if 48 nodes were to be connected, each line receiver or transceiver would have to have no more than 0.67 unit loads (32/48).

The unit load also can be useful when nonstandard bus configurations are implemented. In addition to the differential termination of the differential signal pair, pull-up and pull-down resistors often are connected to the lines to provide a known bus state when all of the connected drivers are idle. The resistor values used for this fail-safe termination are usually around 1 k $\Omega$ . If so, this termination would consume 12 unit loads (12 mA at 12 V) out of the budget of 32 unit loads. This leaves 20 unit loads for the line circuits; and, if 48 nodes are still to be connected, each of the line circuits must now be no more than 0.42 unit loads (20/48).

Texas Instruments (TI) offers numerous options, some of which are shown in Table 1, for supporting a large number of RS-485 bus connections.

**Table 1. Fractional unit-load devices from TI**

UNIT LOADS	MAXIMUM NUMBER OF DEVICES ON A SINGLE BUS SEGMENT	PART NUMBER
0.5	64	SN65HVD05
		SN65HVD10
		SN65HVD20
		SN65HVD23
0.25	128	SN65LBC182
		SN65LBC184
0.125	256	SN65HVD06
		SN65HVD07
		SN65HVD08
		SN65HVD11
		SN65HVD12
		SN65HVD21
		SN65HVD22
		SN65HVD24

### Conclusion

The unit load is a relative parameter that provides a basis for determining the maximum number of connections to an RS-485 bus segment or for specifying the input characteristics of line circuits. A standard RS-485 driver will handle 32 unit loads that could consist of 256 devices with a rating of  $\frac{1}{8}$  unit load.

### Related Web sites

[analog.ti.com](http://analog.ti.com)

[www.ti.com/sc/device/partnumber](http://www.ti.com/sc/device/partnumber)

Replace *partnumber* with SN65HVD05, SN65HVD06, SN65HVD07, SN65HVD08, SN65HVD10, SN65HVD11, SN65HVD12, SN65HVD20, SN65HVD21, SN65HVD22, SN65HVD23, SN65HVD24, SN65LBC182 or SN65LBC184

## IMPORTANT NOTICE

Texas Instruments Incorporated and its subsidiaries (TI) reserve the right to make corrections, modifications, enhancements, improvements, and other changes to its products and services at any time and to discontinue any product or service without notice. Customers should obtain the latest relevant information before placing orders and should verify that such information is current and complete. All products are sold subject to TI's terms and conditions of sale supplied at the time of order acknowledgment.

TI warrants performance of its hardware products to the specifications applicable at the time of sale in accordance with TI's standard warranty. Testing and other quality control techniques are used to the extent TI deems necessary to support this warranty. Except where mandated by government requirements, testing of all parameters of each product is not necessarily performed.

TI assumes no liability for applications assistance or customer product design. Customers are responsible for their products and applications using TI components. To minimize the risks associated with customer products and applications, customers should provide adequate design and operating safeguards.

TI does not warrant or represent that any license, either express or implied, is granted under any TI patent right, copyright, mask work right, or other TI intellectual property right relating to any combination, machine, or process in which TI products or services are used. Information published by TI regarding third-party products or services does not constitute a license from TI to use such products or services or a warranty or endorsement thereof. Use of such information may require a license from a third party under the patents or other intellectual property of the third party, or a license from TI under the patents or other intellectual property of TI.

Reproduction of information in TI data books or data sheets is permissible only if reproduction is without alteration and is accompanied by all associated warranties, conditions, limitations, and notices. Reproduction of this information with alteration is an unfair and deceptive business practice. TI is not responsible or liable for such altered documentation.

Resale of TI products or services with statements different from or beyond the parameters stated by TI for that product or service voids all express and any implied warranties for the associated TI product or service and is an unfair and deceptive business practice. TI is not responsible or liable for any such statements.

Following are URLs where you can obtain information on other Texas Instruments products and application solutions:

### Products

Amplifiers	<a href="http://amplifier.ti.com">amplifier.ti.com</a>
Data Converters	<a href="http://dataconverter.ti.com">dataconverter.ti.com</a>
DSP	<a href="http://dsp.ti.com">dsp.ti.com</a>
Interface	<a href="http://interface.ti.com">interface.ti.com</a>
Logic	<a href="http://logic.ti.com">logic.ti.com</a>
Power Mgmt	<a href="http://power.ti.com">power.ti.com</a>
Microcontrollers	<a href="http://microcontroller.ti.com">microcontroller.ti.com</a>

### Applications

Audio	<a href="http://www.ti.com/audio">www.ti.com/audio</a>
Automotive	<a href="http://www.ti.com/automotive">www.ti.com/automotive</a>
Broadband	<a href="http://www.ti.com/broadband">www.ti.com/broadband</a>
Digital control	<a href="http://www.ti.com/digitalcontrol">www.ti.com/digitalcontrol</a>
Military	<a href="http://www.ti.com/military">www.ti.com/military</a>
Optical Networking	<a href="http://www.ti.com/opticalnetwork">www.ti.com/opticalnetwork</a>
Security	<a href="http://www.ti.com/security">www.ti.com/security</a>
Telephony	<a href="http://www.ti.com/telephony">www.ti.com/telephony</a>
Video & Imaging	<a href="http://www.ti.com/video">www.ti.com/video</a>
Wireless	<a href="http://www.ti.com/wireless">www.ti.com/wireless</a>

## TI Worldwide Technical Support

### Internet

**TI Semiconductor Product Information Center Home Page**  
[support.ti.com](http://support.ti.com)

**TI Semiconductor KnowledgeBase Home Page**  
[support.ti.com/sc/knowledgebase](http://support.ti.com/sc/knowledgebase)

### Product Information Centers

#### Americas

Phone	+1(972) 644-5580	Fax	+1(972) 927-6377
Internet/Email	<a href="http://support.ti.com/sc/pic/americas.htm">support.ti.com/sc/pic/americas.htm</a>		

#### Europe, Middle East, and Africa

Phone			
Belgium (English)	+32 (0) 27 45 54 32	Netherlands (English)	+31 (0) 546 87 95 45
Finland (English)	+358 (0) 9 25173948	Russia	+7 (0) 95 7850415
France	+33 (0) 1 30 70 11 64	Spain	+34 902 35 40 28
Germany	+49 (0) 8161 80 33 11	Sweden (English)	+46 (0) 8587 555 22
Israel (English)	1800 949 0107	United Kingdom	+44 (0) 1604 66 33 99
Italy	800 79 11 37		
Fax	+(49) (0) 8161 80 2045		
Internet	<a href="http://support.ti.com/sc/pic/euro.htm">support.ti.com/sc/pic/euro.htm</a>		

#### Japan

Fax			
International	+81-3-3344-5317	Domestic	0120-81-0036
Internet/Email			
International	<a href="http://support.ti.com/sc/pic/japan.htm">support.ti.com/sc/pic/japan.htm</a>		
Domestic	<a href="http://www.tij.co.jp/pic">www.tij.co.jp/pic</a>		

#### Asia

Phone			
International	+886-2-23786800		
Domestic	Toll-Free Number		
Australia	1-800-999-084	New Zealand	0800-446-934
China	800-820-8682	Philippines	1-800-765-7404
Hong Kong	800-96-5941	Singapore	800-886-1028
Indonesia	001-803-8861-1006	Taiwan	0800-006800
Korea	080-551-2804	Thailand	001-800-886-0010
Malaysia	1-800-80-3973		
Fax	886-2-2378-6808	Email	<a href="mailto:tiasia@ti.com">tiasia@ti.com</a>
Internet	<a href="http://support.ti.com/sc/pic/asia.htm">support.ti.com/sc/pic/asia.htm</a>		<a href="mailto:ti-china@ti.com">ti-china@ti.com</a>

**C011905**

**Safe Harbor Statement:** This publication may contain forward-looking statements that involve a number of risks and uncertainties. These "forward-looking statements" are intended to qualify for the safe harbor from liability established by the Private Securities Litigation Reform Act of 1995. These forward-looking statements generally can be identified by phrases such as "TI or its management believes," "expects," "anticipates," "foresees," "forecasts," "estimates" or other words or phrases of similar import. Similarly, such statements herein that describe the company's products, business strategy, outlook, objectives, plans, intentions or goals also are forward-looking statements. All such forward-looking statements are subject to certain risks and uncertainties that could cause actual results to differ materially from those in forward-looking statements. Please refer to TI's most recent Form 10-K for more information on the risks and uncertainties that could materially affect future results of operations. We disclaim any intention or obligation to update any forward-looking statements as a result of developments occurring after the date of this publication.

**Trademarks:** All trademarks are the property of their respective owners.

Mailing Address: Texas Instruments  
Post Office Box 655303  
Dallas, Texas 75265

© 2005 Texas Instruments Incorporated

SLYT086