

TLC5940 dot correction compensates for variations in LED brightness

By **Michael Day**, *Applications Manager, Portable Power Products* (Email: m-day@ti.com),
and **Tarek Saab**, *Product Marketing Engineer, Portable Power Products* (Email: tareksaab@ti.com)

The abundance of light-emitting diodes (LEDs) in various types of end equipment has surpassed even the most aggressive expectations. The reduction in LED prices, coupled with increased LED efficiency (lumens per watt), has fueled the redesign of many common devices. LEDs are entering new markets such as architectural lighting, LCD TV backlighting, car headlamps, and traffic lights. At the same time, they continue to dominate other markets such as high-quality, large form-factor video displays and alphanumeric displays. As the efficiency and brightness of LEDs improve and the cost decreases, it is anticipated that LED usage will eventually replace conventional lighting methods in consumer applications. Some of these markets, such as LCD TV backlighting and large form-factor video displays, require a much higher degree of LED brightness uniformity than is possible from the LEDs alone. This article shows how the dot correction function in the Texas Instruments (TI) TLC5940 and in other similar LED drivers generates uniform LED brightness across thousands of pixels in these displays.

A stadium or advertising display like that shown in Figure 1 integrates dozens of display panels and thousands of LEDs. The individual LEDs inside each array vary significantly in brightness, with the delta in lumens between the brightest and dimmest LED regularly approaching 15 to 20%, if not more. The design engineer must ensure that each LED is calibrated to provide the same amount of brightness so that when the entire screen is turned on, it appears uniform. Without this calibration, the screen will have a blotchy, uneven look. Even after the display is properly calibrated and deployed to the field, variations in LED aging will generate changes in brightness. As a result, companies must continually solve difficult quality and maintenance issues. To compensate for variations in LED brightness and aging, manufacturers often employ two techniques: First, they purchase matched LEDs from a supplier (also known as “binning”); and second, they utilize a high-quality LED driver with dot correction functionality.

Figure 1. Large form-factor video display



LED suppliers offer the benefit of matched LEDs for an incremental increase in price. They measure and bundle these red, green, and blue (RGB) diodes together with LEDs that generate similar lumens at a specified current. Using this method can provide the desired uniformity with minimal design considerations for low-end lighting systems. However, the variance in decay rate, or degradation in brightness, per pixel over time makes this method a short-lived solution. In other words, in a year or two the picture will become blotchy. Furthermore, should a defective panel need replacement, the lumenal output of the new panel will be visually dissimilar to the others.

High-end display systems require brightness-matching levels that are unattainable by simply binning the LEDs. To achieve pixel and panel uniformity over the *life span* of a display unit, manufacturers use advanced LED drivers with dot correction capability. Dot correction is a method for managing pixel brightness by adjusting the current supplied through each individual LED in the array. The dot correction feature enables the processor to control full current to a panel of LEDs while the LED driver scales the current to each LED and creates uniform brightness. This frees the processor for other functions, since it no longer has to check a look-up table or perform complex multiplication tasks for each LED in every refresh cycle.

To implement dot correction, manufacturers measure the brightness of individual LEDs through photo capture. The dimmest LED in the system is designated as the “base” LED to which every other pixel is matched. To accomplish this calibration, the current supplied to each pixel is multiplied by a fractional value proportional to the LED’s luminal output. In a device like TI’s TLC5940, the dot correction value for each LED can be dynamically changed every refresh cycle or stored inside an integrated EEPROM. This dual dot correction method offers the flexibility to update overall panel brightness as external lighting conditions change, and provides long-term, nonvolatile dot correction

information that ensures panel uniformity. The EEPROM data can be rewritten as luminal measurements vary over time or as panels fail, requiring correction or replacement, respectively. The following example shows how dot correction is used to match LED brightness at production.

A typical display panel has anywhere from dozens to thousands of LED drivers and from hundreds to hundreds of thousands of individual LEDs. For simplicity, this example considers only the 16 LEDs connected to a single driver. Figure 2 shows the typical schematic of a single driver. An external power supply, V_{LED} , provides the power to the LEDs. R_{EXT} sets the absolute maximum current through any LED. An external processor programs the TLC5940 to turn on or off each individual LED and to set its current to a percentage of the maximum programmed current.

The first step in calibrating a panel’s brightness is to set the maximum current. This example requires a green LED to have a luminous intensity of 80 millicandela (mcd). The LED (Osram LP E675) is available in 4 different luminosity bins: 45–56, 56–71, 71–90, and 90–112 mcd, each measured at a normalized current of 50 mA. Selecting the highest bin guarantees at least 80 mcd per LED. R_{EXT} must set the current high enough to allow even the dimmest LED to produce 80 mcd. According to the datasheet for the LP E675, setting the LED current to 43 mA guarantees

Figure 2. Typical TLC5940 implementation

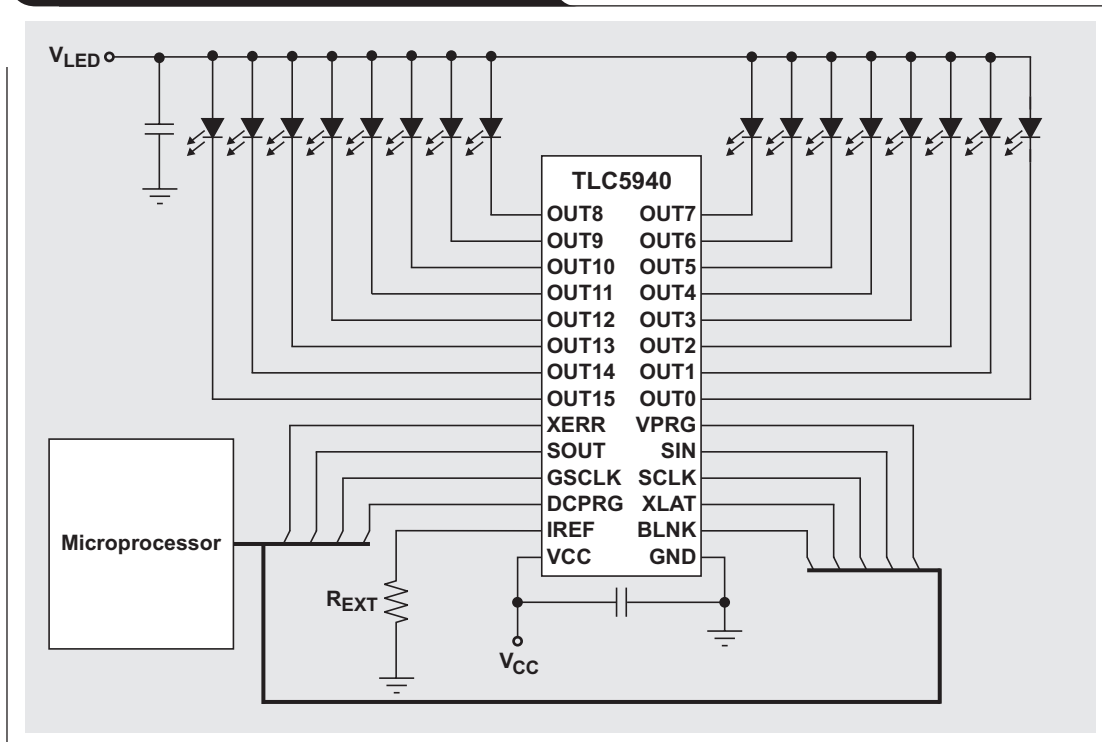

80 mcd. At production, the brightness of all LEDs is measured at full current (43 mA). This might produce an LED histogram of luminous intensity resembling Figure 3. As shown, the brightness variation measured between each LED in the panel may vary as much as $\pm 10\%$ without dot correction. A brightness deviation this large is unacceptable in higher-end displays. The TLC5940 dot correction feature can now be used to calibrate the LED brightness. When programmed to full brightness, the IC must dot correct the luminous intensity of LED1 from 83 mcd to 80 mcd. The TLC5940 has 6-bit dot correction (64 steps), which corresponds to a full-scale resolution of 1.56% per step.

The following formula calculates the correct dot correction level for each LED:

$$DC_{\text{Production}} = \frac{L_{\text{Baseline}}}{L_{\text{Initial}}} \times 64 = 61.7,$$

where $DC_{\text{Production}}$ is the required dot correction value at production, L_{Baseline} is the desired brightness level, and L_{Initial} is the measured brightness at maximum current.

By rounding the calculated dot correction value to the closest fractional number and then multiplying the original luminosity by the new dot correction ratio, one can produce the updated LED brightness.

$$L_{\text{Production}} = \frac{DC_{\text{Production}}}{64} \times L_{\text{Initial}} = 80.4 \text{ mcd}$$

After the dot correction values are calculated and stored, the TLC5940 is capable of automatically generating a uniform brightness in all LEDs. When the processor programs the TLC5940 to drive full current, the TLC5940 automatically adjusts the actual current in each channel to properly calibrate the LED brightness. The current in LED1 is calculated as

$$I_{\text{LED1}} = \frac{DC_{\text{LED1}}}{64} \times I_{\text{max}} = 41.66 \text{ mA},$$

where I_{LED1} is the actual LED1 current, DC_{LED1} is the dot correction value for LED1 (62), and I_{max} is the maximum LED current programmed by R_{EXT} (43 mA). Applying these

Figure 3. LED brightness and forward current histogram before dot correction

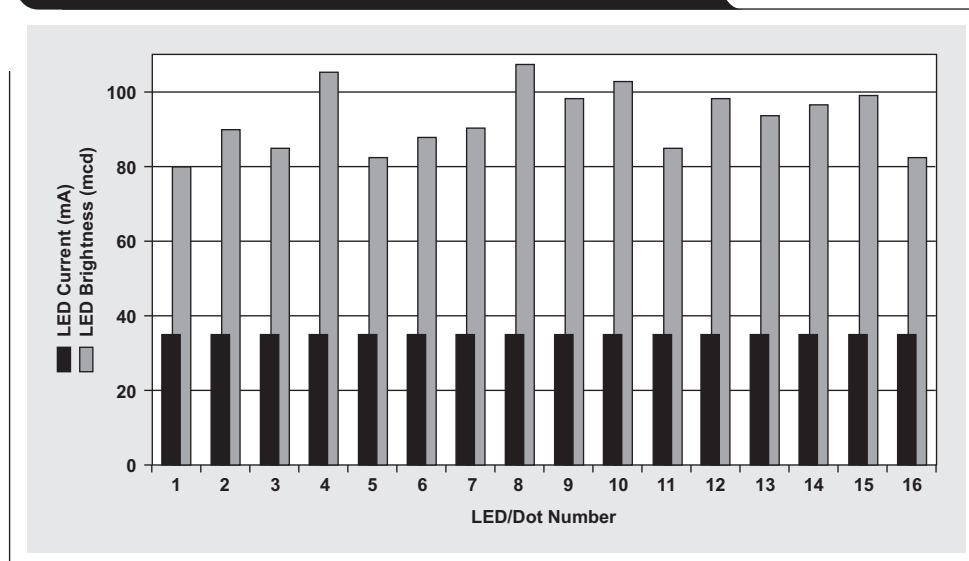

formulas to the remaining LEDs produces the histogram in Figure 4. If programmed into the TLC5940's nonvolatile EEPROM, the dot correction data is available each time the panel is turned on and remains constant until the next time the panel is recalibrated.

For indoor/outdoor industrial applications such as billboards and large form-factor video displays, "static" adjustment (calibration that remains fixed until manually adjusted) is sufficient. dot correction values don't change until the next routine maintenance cycle. The newer market applications such as LCD TV backlighting require a dynamic dot correction scheme. Products such as the Sony 40" Qualia 005 and the Samsung 46" LNR460D have each introduced LCD TVs that incorporate LED-based backlighting. Contrary to popular belief, the diodes in these TV displays are not white. RGB LEDs are controlled and mixed to create "tunable" white light.

The advantages of LED backlighting over conventional lamps are numerous: enhanced power efficiency, reduced motion artifacts, broader color spectrum (>105% NTSC in some cases), longer life span, tunable color temperature, etc. The picture quality is incomparable. However, LCD TV engineers encounter not only the same luminal variance challenges as conventional panel makers but also temperature concerns. TV backlighting applications are sensitive to changes in LED brightness as a function of temperature. In addition, a TV set achieves optimum display quality only when its backlighting properties are adjusted to meet the constantly changing ambient lighting conditions for each consumer's living room. These considerations, coupled with the fact that this is a consumer application, create a need for dynamic brightness adjustment.

To create this dynamic control loop, internal sensors that measure LED temperature and brightness fluctuations, as well as external sensors that measure ambient-light conditions, are required. The control loop, in its most basic form, begins with the sensors gathering data and feeding these measurements into a processor. The processor evaluates this data and provides the "intelligence" to an LED driver such as the TLC5940. The processor combines the original factory-calibrated dot correction data with the new, dynamic data and generates updated dot correction values.

In the previous example, if the ambient-light meter detects low ambient-light conditions that require only 70% of full

Figure 4. LED brightness and forward current histogram after dot correction

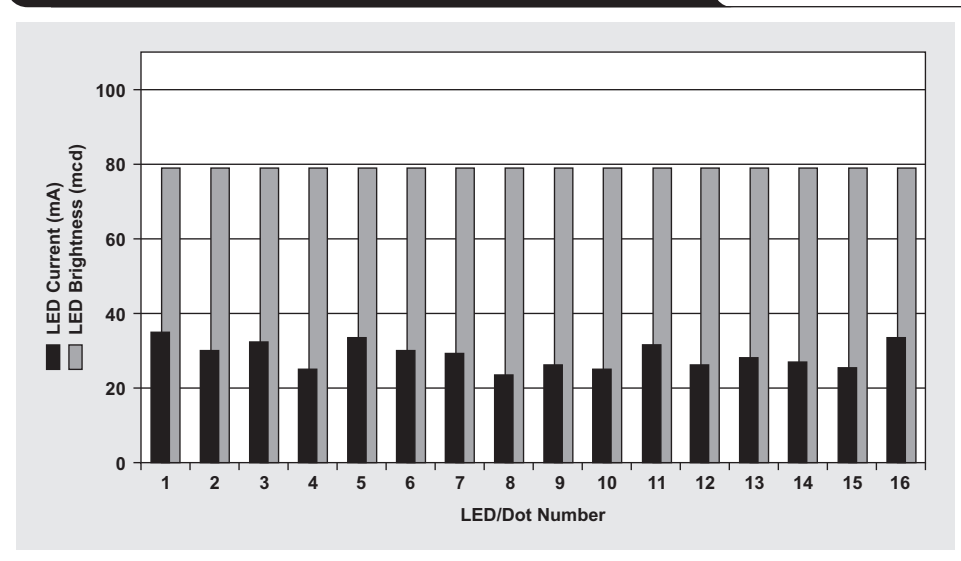

brightness, or 56 mcd, the processor calculates a new ambient-light dot correction value of 44.8. If, simultaneously, the LED light output drops 10% due to an increase in temperature, the processor calculates a temperature dot correction value of 71.1. Combining all three dot correction values generates the new dot correction data, compensating for all three brightness variations.

$$DC_{\text{Ambient}} = \frac{80 \times 0.7}{80} \times 64 = 44.8$$

$$DC_{\text{Temp}} = \frac{80}{80 \times 0.9} \times 64 = 71.1$$

$$DC_{\text{Total}} = \left(\frac{DC_{\text{Ambient}}}{64} \right) \left(\frac{DC_{\text{Temp}}}{64} \right) \left(\frac{DC_{\text{Production}}}{64} \right) 64 = 48.0$$

As shown in the following equation, the combined dot correction value of 48 yields the desired brightness of 56 mcd. Note that the initial current in this calculation is set to 90% of the initial production current due to the brightness drop caused by the temperature.

$$L_{\text{Final}} = \left(\frac{DC_{\text{Total}}}{64} \right) (83 \times 0.9) = \frac{48}{64} \times 74.7 = 56 \text{ mcd}$$

Advanced LED drivers such as the TLC5940 are capable of providing a dynamic dot correction value to optimize the lighting solution for a consumer's specific viewing conditions.

Related Web sites

power.ti.com

www.ti.com/sc/device/TLC5940