

Power Supply Design for Renesas R-Car M3 Using LP87565U-Q1, LP873245-Q1, and LP87334A-Q1



ABSTRACT

This document details the design considerations of a power solution for the Renesas R-Car M3x SoC (system-on-chip) power rails using the LP87565-Q1, LP8733-Q1, and LP8732-Q1 power management ICs. Additional TLV733P-Q1 LDOs are used for the peripheral rails. This power solution assumes an input voltage of 5 V (+/-5%). If the system input voltage is higher, for example a car battery, a buck converter as a pre-regulator should be used to generate a supply voltage of 5 V.

The LP87565-Q1 has four buck converters configured to work as dual 2-phase converters. LP8732-Q1 has two 2 A buck converters and two 300 mA LDOs. LP8733-Q1 has two 3 A buck converters and two 300 mA LDOs. These devices are OTP programmable, meaning default register values are set in TI production line to desired values for this platform without further need for customer to change settings. Full orderable part numbers for these OTP spins are LP87565URNFRQ1, LP87334ARHDRQ1, and LP873245RHDRQ1. See the Technical Reference Manuals for the specific part numbers for more details on the OTP settings.

This power solution is an example how R-Car M3x required rails can be powered with TI PMICs. Sequencing is handled through programmable startup/shutdown delays of the PMICs and GPIOs and it only requires a single Enable signal from the system to initiate the sequencing. This power solution is possible to customize and optimize based on the actual use case regarding SoC variant, current requirements, used peripherals, and so forth.

Reference design with TI power solution and R-Car M3W SoC + all needed peripherals, memory, and connections was designed and built to confirm the functionality and performance of the power solution. Design files, software, and documentation are available on request to help integrating TI power solution to customer system. This solution supports fully DVFS and AVS for core rail through I²C bus.

Table of Contents

1 Design Parameters	3
2 Power Solution	4
3 Sequencing	5
3.1 Startup.....	5
3.2 Shutdown.....	6
4 Schematic	7
5 Software Drivers	10
6 System Solution	11
7 Recommended External Components	12
8 Measurements	13
9 Summary	14
10 References	15
11 Revision History	15

List of Figures

Figure 2-1. R-Car M3W Power Solution Block Diagram.....	4
Figure 3-1. R-Car M3-W Power Startup Timing Diagram.....	5
Figure 3-2. Shutdown Timing Diagram.....	6
Figure 4-1. LP87565-Q1 Schematic.....	7
Figure 4-2. LP8732-Q1 Schematic.....	7
Figure 4-3. LP8733-Q1 Schematic.....	8

Figure 4-4. TLV733P-Q1 LDO Schematic.....	8
Figure 4-5. Connections to R-Car M3-W.....	9
Figure 6-1. R-Car Reference Design Board.....	11
Figure 8-1. LP87565-Q1 Efficiency with $V_{in} = 5\text{ V}$, 25°C , $V_{out} = 0.85\text{ V}$	13
Figure 8-2. LP8732-Q1/LP8733-Q1 Efficiency with $V_{in} = 5\text{ V}$, 25°C	13

List of Tables

Table 1-1. Design Parameters.....	3
Table 7-1. Bill of Materials.....	12

Trademarks

All trademarks are the property of their respective owners.

1 Design Parameters

Table 1-1 shows the power rails, load requirements, and startup/shutdown sequencing requirements and Measurements shows typical measurement data.

Table 1-1. Design Parameters

VOLTAGE (V)	RAIL NAME	LOAD CAPABILITY (mA)	SOURCE	STARTUP DELAY (ms)	SHUTDOWN DELAY (ms)
1.8	DDR0_1.8V	300	LP873245-Q1 LDO0	5	15
	DDR1_1.8V	300	LP873245-Q1 LDO1	5	15
1.1	VDDQVA_DDR0	2000	LP873245-Q1 Buck0	11	9
	VDDQVA_DDR1	2000	LP873245-Q1 Buck1	11	9
1.8	VDDQ18	2000	LP87334A-Q1 Buck0	10	10
	VDDIO_1V8	300	#1 TLV733P-Q1	2	18
	VDDQVA_SD1	300	#2 TLV733P-Q1	12	8
	VDDQVA_SD2	300	#3 TLV733P-Q1	12	8
	VDDQVA_SD3	300	#4 TLV733P-Q1	12	8
3.3	VDDQVA_SD0	300	LP87334A-Q1 LDO0	12	8
	VDDQ33	3000	LP87334A-Q1 Buck1	9	11
	VDDIO_3V3	300	#5 TLV733P-Q1	2	18
0.9	VDD_DVFS	8000	LP87565U-Q1 Buck0+1	8	12
0.82	VDD	8000	LP87565U-Q1 Buck2+3	6	14
2.5	VDDQ25_ETH	300	LP87334A-Q1 LDO1	10	10
-	nRESET (PGOOD)	-	PGOOD / LP87565U-Q1 GPIO3	22	0

2 Power Solution

Figure 2-1 shows an example block diagram of LP87565U-Q1, LP873245-Q1, LP87334A-Q1, and 5 pcs TLV733P-Q1 devices powering the R-Car M3-W power rails.

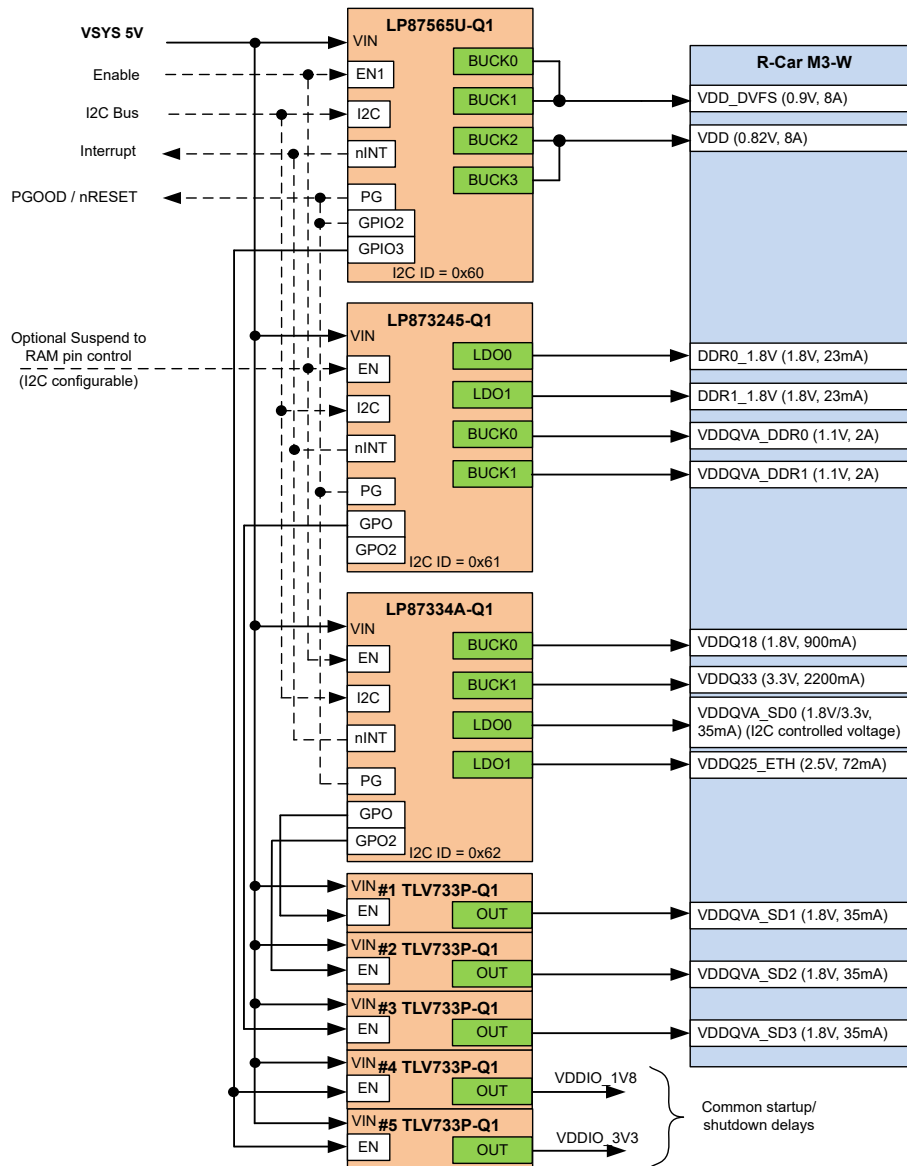

Figure 2-1. R-Car M3W Power Solution Block Diagram

Main features:

- After the devices are powered, the microcontroller can set the EN pin high to initiate the startup sequence.
- Startup delays are controlled internally in the LP87565U-Q1, LP873245-Q1, and LP87334A-Q1 logic and TLV733P-Q1s are controlled with PMIC GPIOs.
- I²C can be used to read status registers and reset interrupts.
- All PMIC devices have dedicated I²C slave address so they can share the same I²C bus.
- PGOOD signals act as nRESET signal for the SoC and LP87565U-Q1 GPIO2 keeps the signal low at startup for predefined time.
- Voltage control (1.8 V / 3.3 V) VDDQVA_SD0 rail done through I²C bus
- AVS/DVFS support through I²C

3 Sequencing

3.1 Startup

Figure 3-1 shows an example startup timing of the power rails and corresponding signals.

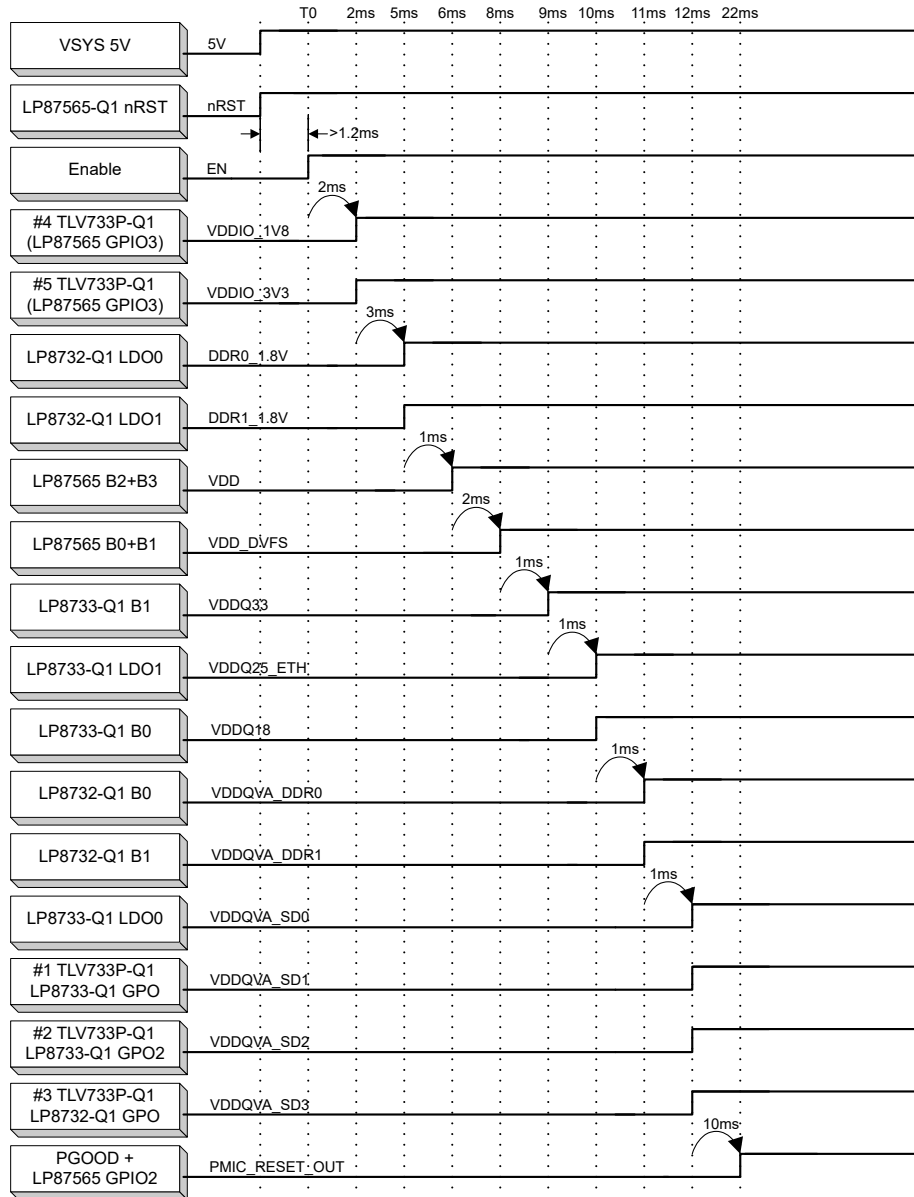

Figure 3-1. R-Car M3-W Power Startup Timing Diagram

3.2 Shutdown

Figure 3-2 shows an example of shutdown timing of the power rails and corresponding signals.

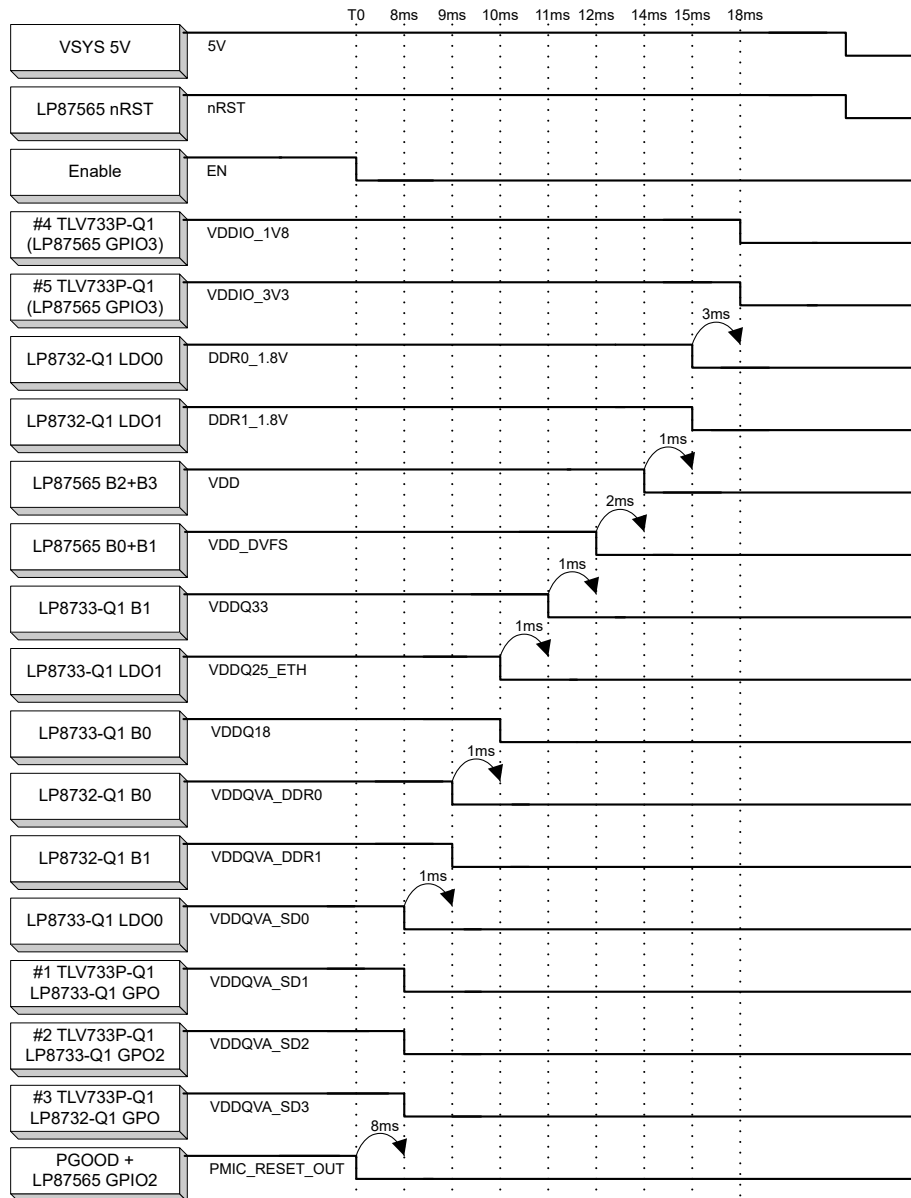

Figure 3-2. Shutdown Timing Diagram

4 Schematic

Figure 4-1 through Figure 4-5 show the R-Car M3-W power tree schematic with critical components. Snubbers are needed for LP87565-Q1 when input voltage of the system is >4 V, otherwise they are optional.

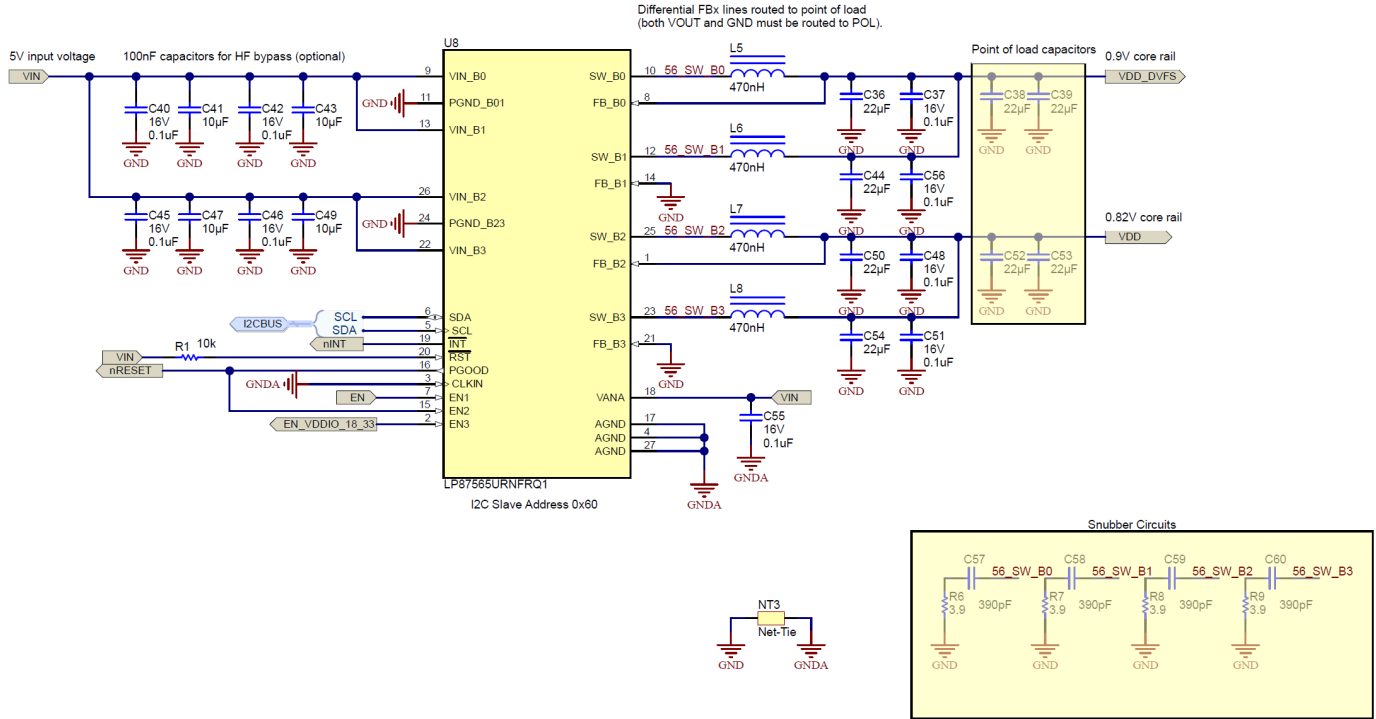

Figure 4-1. LP87565-Q1 Schematic

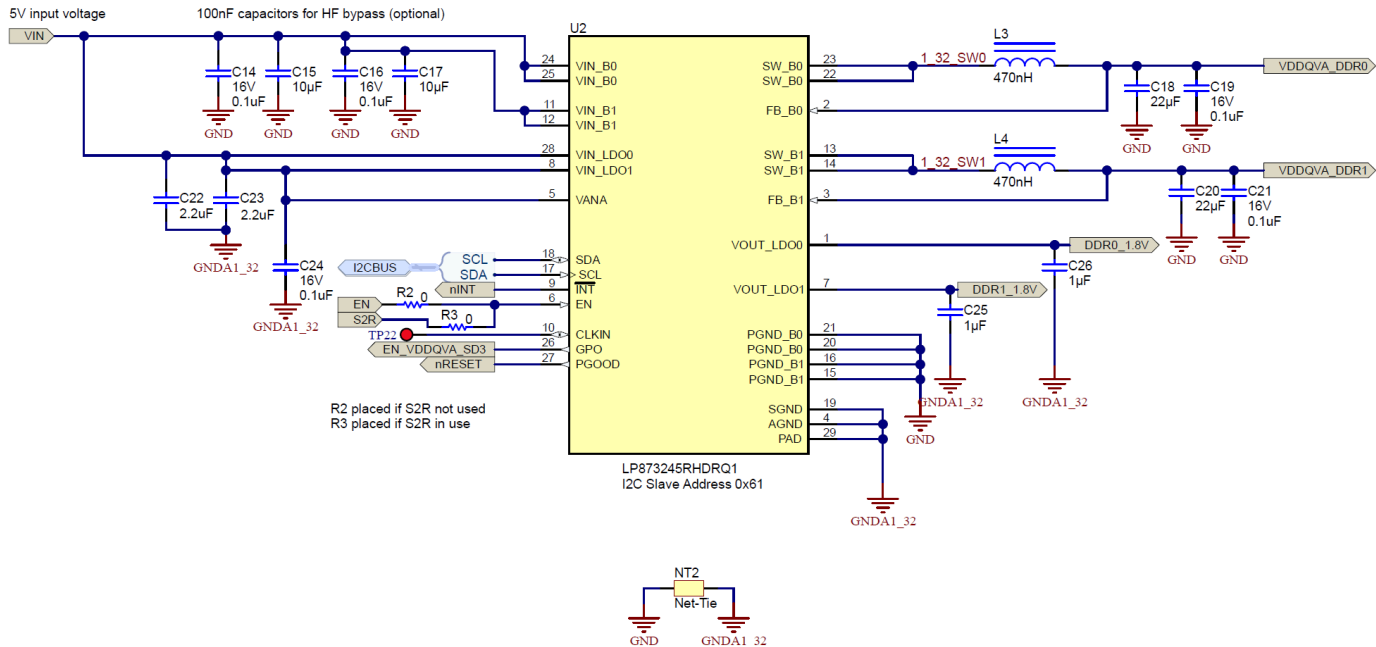

Figure 4-2. LP8732-Q1 Schematic

Schematic

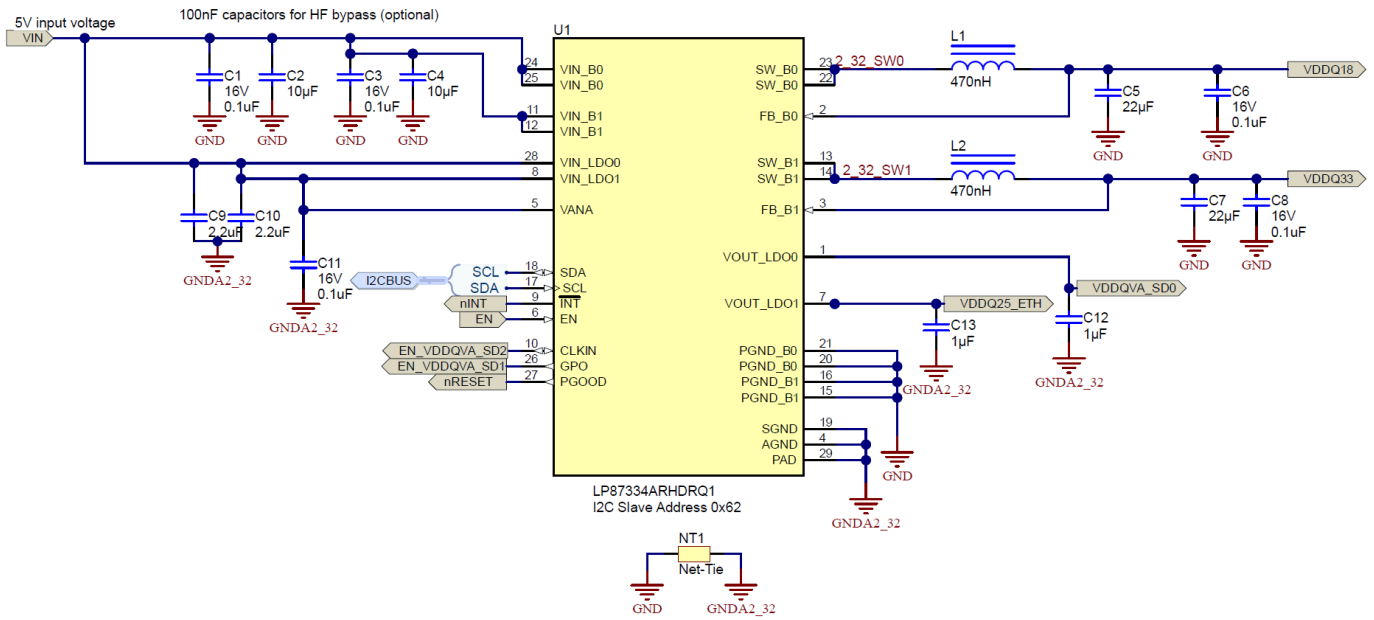

Figure 4-3. LP8733-Q1 Schematic

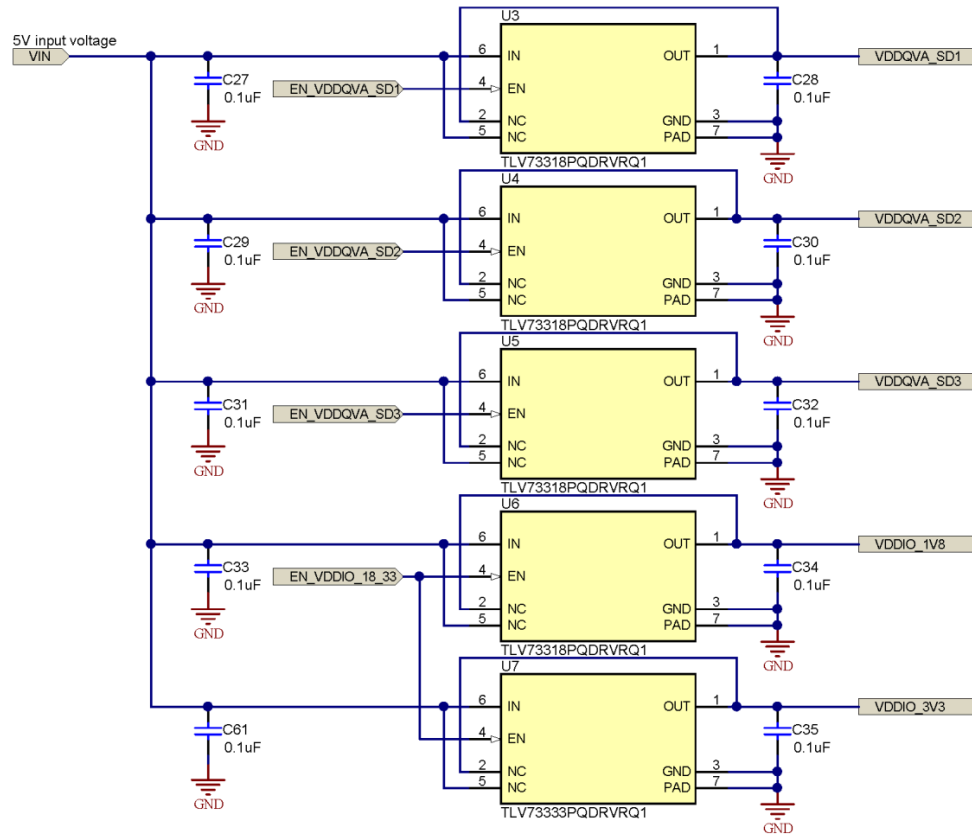

Figure 4-4. TLV733P-Q1 LDO Schematic

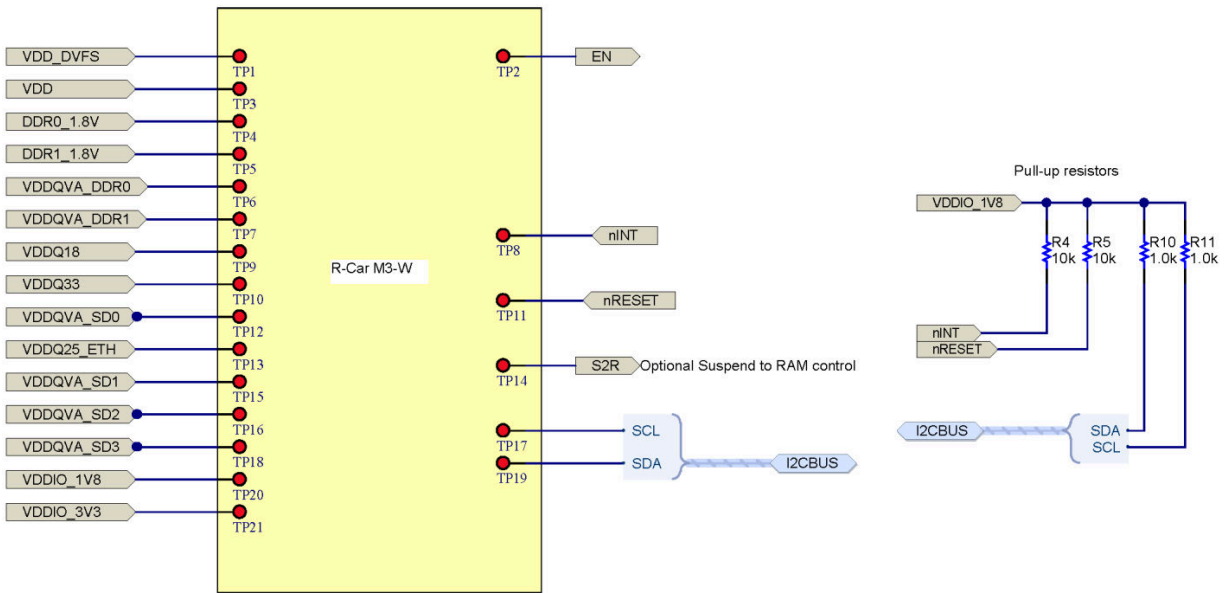

Figure 4-5. Connections to R-Car M3-W

5 Software Drivers

This solution supports AVS and DVFS for core rail through I²C bus.

Linux drivers for the LP875x and LP873x are available in public git repository. These can be used to help integrate the LP875x / LP873x control to system software:

LP8756x

- <https://github.com/torvalds/linux/blob/master/drivers/mfd/lp87565.c>
- <https://github.com/torvalds/linux/blob/master/drivers/regulator/lp87565-regulator.c>
- <https://github.com/torvalds/linux/blob/master/drivers/gpio/gpio-lp87565.c>

LP873x

- <https://github.com/torvalds/linux/blob/master/drivers/mfd/lp873x.c>
- <https://github.com/torvalds/linux/blob/master/drivers/regulator/lp873x-regulator.c>
- <https://github.com/torvalds/linux/blob/master/drivers/gpio/gpio-lp873x.c>

Note: Every header file is in the *include* folder starting from the root directory. So once in *include folder*, the user can navigate to the relevant header file. For example, the LP87565.h file: <https://github.com/torvalds/linux/blob/master/include/linux/mfd/lp87565.h>.

See [System Solution](#) for more details on the full reference design board and software.

6 System Solution

This section has details on the full reference design board with R-Car M3-W SoC as well as all the peripherals, memory, and connections. This is powered with TI power solution and software has been updated to allow DVFS and AVS control for the core rail power.

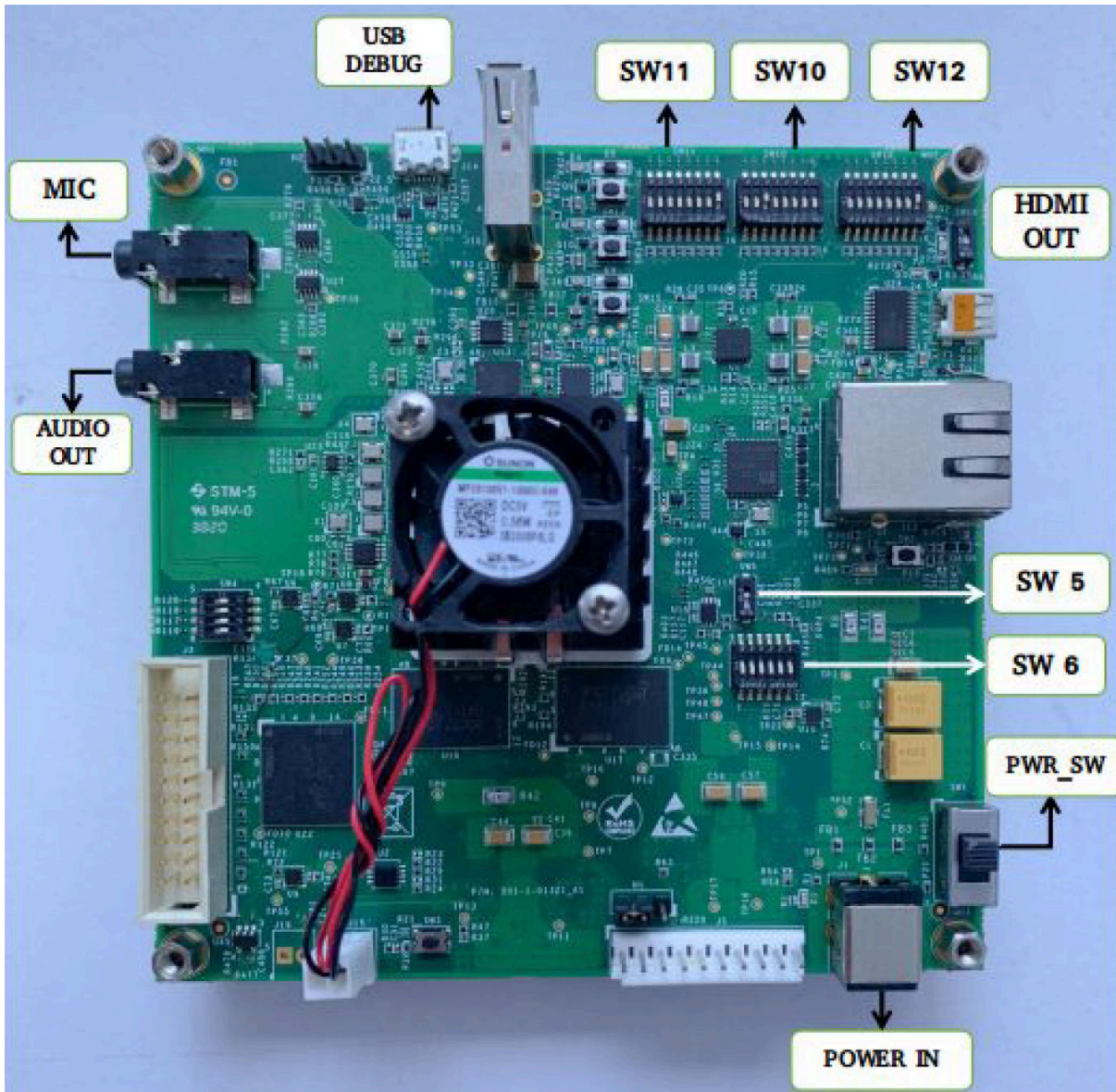

Figure 6-1. R-Car Reference Design Board

Software for the board is based on embedded Linux (Yocto). Full design files, details on the software/driver implementation, and more detailed documentation is available on request. See links below.

General Information on R-Car Software Development

<https://elinux.org/R-Car>

Design Files, Software, Documentation

https://www.ti.com/licreg/docs/swlicexportcontrol.tsp?form_id=300248&prod_no=LP875X-Q1_LP873X-Q1_TPS65917-Q1_DESIGN_DOCS&ref_url=APP-BMC-IPM

Note: You need to have active ti.com account and request for access for the files. Once your request has been processed and approved, you can download the files from <https://www.ti.com/mysecuresoftware>.

7 Recommended External Components

Table 7-1 shows the recommended external components to use in this solution with the LP87565-Q1, LP8732-Q1, LP8733-Q1, and TLV-733P-Q1s. It also shows the total solution size, including the PMIC device and the external components.

Table 7-1. Bill of Materials

COUNT	VENDOR	PART NUMBER	SYSTEM COMPONENT	W (mm)	L (mm)	H (mm)	UNIT AREA ⁽¹⁾	TOTAL BOARD AREA ⁽¹⁾
1	TI	LP87565URNF RQ1	Configurable 4-phase PMIC	4.00	4.50	0.90	27.50	27.50
4	Murata	DFE252012PD -R47M	LP87565 Inductor 0.47 μ H, I _{max} 4.0 A, R _{dc} typ 21m Ω	2.50	2.00	1.20	10.50	42.00
4	Murata	GCM21BR71A 106KE22	LP87565 SMPS Input Capacitor 10 μ F, 10 V, 10%	2.00	1.25	1.25	6.75	27.00
4	Murata	GCM31CR71A 226KE02	LP87565 SMPS Output Capacitor 22 μ F, 10 V, 10%	3.20	1.60	1.80	10.92	43.68
13	Murata	GRT31CC80J4 76KE13	Point of load Capacitor 47 μ F, 6.3 V, 10%.	3.20	1.60	1.60	10.92	141.96
1	Murata	GCM155R71C 104KA55D	LP87565 Input Capacitor 0.1 μ F, 16 V, 10%	1.00	0.50	0.50	3.00	3.00
4	TDK	CGA2B2C0G1 H391J050BA	LP87565 Snubber capacitor, 390 pF	1.00	0.50	0.50	3.00	12.00
4	Vishay-Dale	CRCW04023R 90JNED	LP87565 Snubber resistor, 3R9	1.00	0.50	0.50	3.00	12.00
1	TI	LP873245RHD RQ1	Configurable PMIC with 2 Bucks and 2 LDOs	5.00	5.00	0.90	36.00	36.00
1	TI	LP87334ARHD RQ1	Configurable PMIC with 2 Bucks and 2 LDOs	5.00	5.00	0.90	36.00	36.00
4	Murata	DFE252012PD -R47M	LP873x Inductor 0.47 μ H, I _{max} 4.0 A, R _{dc} typ 21m Ω	2.50	2.00	1.20	10.50	42.00
4	Murata	GCM21BR71A 106KE22	LP873x SMPS Input Capacitor 10 μ F, 10 V, 10%	2.00	1.25	1.25	6.75	27.00
4	Murata	GCM31CR71A 226KE02	LP873x SMPS Output Capacitor 22 μ F, 10 V, 10%	3.20	1.60	1.60	10.92	43.68
4	Murata	GCM188R70J2 25KE22	LP873x LDO Input Capacitor 2.2 μ F, 6.3 V, 10%	1.60	0.80	0.90	4.68	18.72
4	Murata	GCM188R71C 105KA64	LP873x LDO Output Capacitor 1.0 μ F, 16 V, 10%	1.60	0.80	0.90	4.68	18.72
1	Murata	GCM155R71C 104KA55D	LP873x Input Capacitor 0.1 μ F, 16 V, 10%	1.00	0.50	0.50	3.00	3.00
4	TI	TLV733P-Q1	TLV733P-Q1 Low Dropout Regulator	2.00	2.00	0.80	9.00	45.00
4	Murata	GCM155R71C 104KA55D	TLV733P-Q1 Input Capacitor 0.1 μ F, 16 V, 10%	1.00	0.50	0.50	3.00	15.00
4	Murata	GCM155R71C 104KA55D	TLV733P-Q1 Output Capacitor 0.1 μ F, 16 V, 10%	1.00	0.50	0.50	3.00	15.00
TOTAL								609.26 mm ²
Routing area calculated with 0.3 routing factor								261.11 mm ²
Total area								870.37 mm ²

(1) Assuming 1 mm keep-out around each component, and multiplying by component count

8 Measurements

Test data can be found in the Application Curves section of the [LP8756x-Q1 16A Buck Converter With Integrated Switches Data Sheet](#), [LP8732xx-Q1 Dual High-Current Buck Converter and Dual Linear Regulator Data Sheet](#), and the [LP8733xx-Q1 Dual High-Current Buck Converter and Dual Linear Regulator Data Sheet](#)

Additional bench test data for efficiency in specific conditions for this power tree can be seen in this section.

Measurements were taken on the LP87565Q1EVM and LP8733Q1EVM with default components.

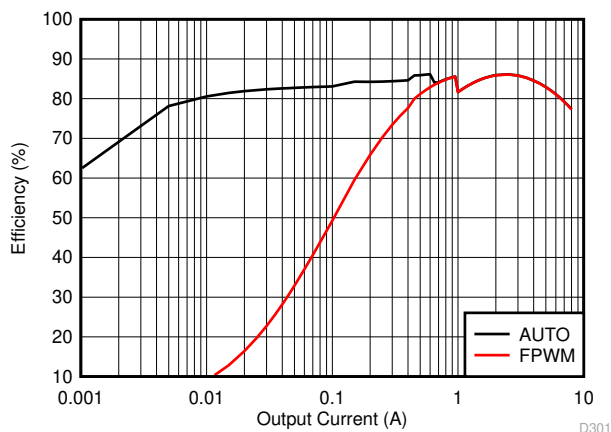

Figure 8-1. LP87565-Q1 Efficiency with $V_{in} = 5\text{ V}$, 25°C , $V_{out} = 0.85\text{ V}$

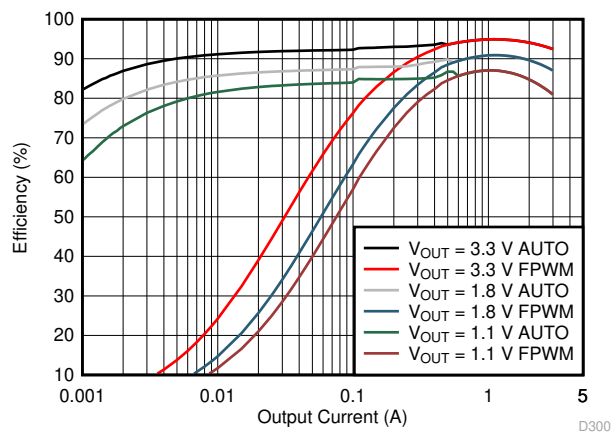

Figure 8-2. LP8732-Q1/LP8733-Q1 Efficiency with $V_{in} = 5\text{ V}$, 25°C

9 Summary

With this presented solution with the LP87565-Q1, LP8732-Q1, and LP8733-Q1 PMICs, it is possible to meet power requirements for R-Car M3 application processor while maintaining good efficiency. Sequencing is handled in PMICs and only one EN signal is needed from the controller. Solution is compact due to minimum number of external components. I²C control allows AVS and DVFS for core rails. Design files for the development platform including hardware, software, and detailed documentation are available on request.

10 References

See these references for additional information:

1. Texas Instruments, [LP8756x-Q1 16A Buck Converter With Integrated Switches Data Sheet](#) (SNVSB22)
2. Texas Instruments, [LP87565U-Q1 Technical Reference Manual](#) (SNVU816)
3. Texas Instruments, [LP8732xx-Q1 Dual High-Current Buck Converter and Dual Linear Regulator Data Sheet](#) (SNVSB63)
4. Texas Instruments, [LP873245-Q1 Technical Reference Manual](#) (SNVU814)
5. Texas Instruments, [LP8733xx-Q1 Dual High-Current Buck Converter and Dual Linear Regulator Data Sheet](#) (SNVSB64)
6. Texas Instruments, [LP87334A-Q1 Technical Reference Manual](#) (SNVU813)
7. Texas Instruments, [LP8756x-Q1 Configuration Guide](#) (SNVU590)
8. Texas Instruments, [LP8733-Q1 and LP8732-Q1 Configuration Guide](#) (SNVU582)

11 Revision History

NOTE: Page numbers for previous revisions may differ from page numbers in the current version.

Changes from Revision * (May 2019) to Revision A (October 2021)	Page
• Updated abstract to include full part numbers and information about full reference design availability.....	1
• Updated design parameters with full part numbers. Updated load currents.....	3
• Updated block diagram to include full part numbers.....	4
• Updated sequencing part numbers for PMICs.....	5
• Updated Schematic with full part numbers.....	7
• Updated Software Drivers to include link to System Solution section.....	10
• Added System solution section.....	11
• Updated Recommended External Components PMIC part numbers.....	12
• Added link to LP8733-Q1 datasheet in Measurement section.....	13
• Updated Summary to include LP8733-Q1 and added note about reference design files.....	14
• Updated reference links to include LP8733-Q1 datasheet, LP87565U-Q1 TRM, LP873245-Q1 TRM, and LP87334A-Q1 TRM.....	15

IMPORTANT NOTICE AND DISCLAIMER

TI PROVIDES TECHNICAL AND RELIABILITY DATA (INCLUDING DATA SHEETS), DESIGN RESOURCES (INCLUDING REFERENCE DESIGNS), APPLICATION OR OTHER DESIGN ADVICE, WEB TOOLS, SAFETY INFORMATION, AND OTHER RESOURCES "AS IS" AND WITH ALL FAULTS, AND DISCLAIMS ALL WARRANTIES, EXPRESS AND IMPLIED, INCLUDING WITHOUT LIMITATION ANY IMPLIED WARRANTIES OF MERCHANTABILITY, FITNESS FOR A PARTICULAR PURPOSE OR NON-INFRINGEMENT OF THIRD PARTY INTELLECTUAL PROPERTY RIGHTS.

These resources are intended for skilled developers designing with TI products. You are solely responsible for (1) selecting the appropriate TI products for your application, (2) designing, validating and testing your application, and (3) ensuring your application meets applicable standards, and any other safety, security, regulatory or other requirements.

These resources are subject to change without notice. TI grants you permission to use these resources only for development of an application that uses the TI products described in the resource. Other reproduction and display of these resources is prohibited. No license is granted to any other TI intellectual property right or to any third party intellectual property right. TI disclaims responsibility for, and you will fully indemnify TI and its representatives against, any claims, damages, costs, losses, and liabilities arising out of your use of these resources.

TI's products are provided subject to [TI's Terms of Sale](#) or other applicable terms available either on ti.com or provided in conjunction with such TI products. TI's provision of these resources does not expand or otherwise alter TI's applicable warranties or warranty disclaimers for TI products.

TI objects to and rejects any additional or different terms you may have proposed.

Mailing Address: Texas Instruments, Post Office Box 655303, Dallas, Texas 75265
Copyright © 2022, Texas Instruments Incorporated