

K2GEVM

TABLE OF CONTENTS

PAGE	CONTENTS
01	TABLE OF CONTENTS
02	REVISION HISTORY
03	BLOCK DIAGRAM - K2G EVM
04	BLOCK DIAGRAM - BMC
05	BLOCK DIAGRAM - XDS200
06	POWER FLOW DIAGRAM
07	BOARD POWER SEQUENCE DIAGRAM
08	I2C ADDRESS TABLE & McASP CONFIGURATION
09	MCASP TREE
10	SoC CLOCK & RESET
11	SoC GPIO & RESERVED PINS
12	SoC POWER1
13	SoC POWER2
14	DDR3 DEVICES
15	DDR3 ECC & TERMINATIONS
16	QSPI, I2C EEPROM & SPI NOR FLASH
17	EMMC FLASH
18	NAND FLASH & MICRO SD CARD
19	HDMI OR LCD MUX
20	LCD & TOUCH SCREEN CONNECTOR
21	HDMI TRANSMITTER
22	AUDIO CODEC
23	MCASP2 BUFFERS FOR COM8 , HDMI& AUDIO CODEC
24	ETHERNET PHY
25	PCIE x1 CONNECTOR
26	USB DUAL ROLE & HOST
27	UART0 & UART1
28	UART2
29	COM8 CONNECTOR
30	MLB CONNECTOR
31	DCAN
32	McASP & AUDIO EXPANSION CONNECTOR
33	SERIAL & EHRPWM EXPANSION CONNECTOR
34	SERIAL CONTROL INTERFACES & I/O EXPANDER
35	CLOCK DISTRIBUTION 1
36	CLOCK DISTRIBUTION 2

PAGE	CONTENTS
37	EMU & MIPI60 CONNECTOR
38	JTAG_XDS200_1
39	JTAG_XDS200_2
40	JTAG_XDS200_3
41	JTAG_XDS200_4
42	JTAG_XDS200_CPLD
43	XDS200 POWER
44	BOARD MANAGEMENT CONTROL_1 (BMC)
45	BOARD MANAGEMENT CONTROL_2 (BMC)
46	BOARD MANAGEMENT CONTROL_3 (BMC)
47	PMIC POWER1
48	PMIC POWER2
49	12V DC IN, 5V & DDR3 POWER GENERATION
50	OVER VOLTAGE PROTECTION
51	

REV	A
VER	1.00

Designed for TI by Mistral Solutions Pvt Ltd



Title TABLE OF CONTENTS

Size	Variant Name = Proj PROC046 002 OPN# EVMK2GXS	Rev
C		A
Date:	Friday, February 02, 2018	Sheet 1 of 51

REVISION HISTORY

VER #	DATE	DESCRIPTION OF CHANGES	AUTHOR
0.1	17th July 2017	Drafted from "MS_TI_K2GEVM_SCH_REVD_1V5" document.	Mistral Design Team
0.2	17th July 2018	- Changed 66AK2G02 (600MHz) to X66AK2G12ABY100(1GHz) Part - Changed PMIC IC TPS659118 to TPS65911A - Changed Load switch TPS22907YZTR to TPS22913BYZVR	Mistral Design Team
0.3	18th July 2019	For Review	Mistral Design Team
1.0	18th July 2018	Baselined	Mistral Design Team

NOTE: Refer to MS_TI_K2GEVM_REVD_ECR_ECN document for changes implemented on version 1.6

Designed for TI by Mistral Solutions Pvt Ltd



Title REVISION HISTORY

Size	Variant Name = Proj PROC046 002 OPN# EVMK2GXS	Rev
C		A
Date:	Friday, February 02, 2018	Sheet 2 of 51

BLOCK DIAGRAM - K2GEVM

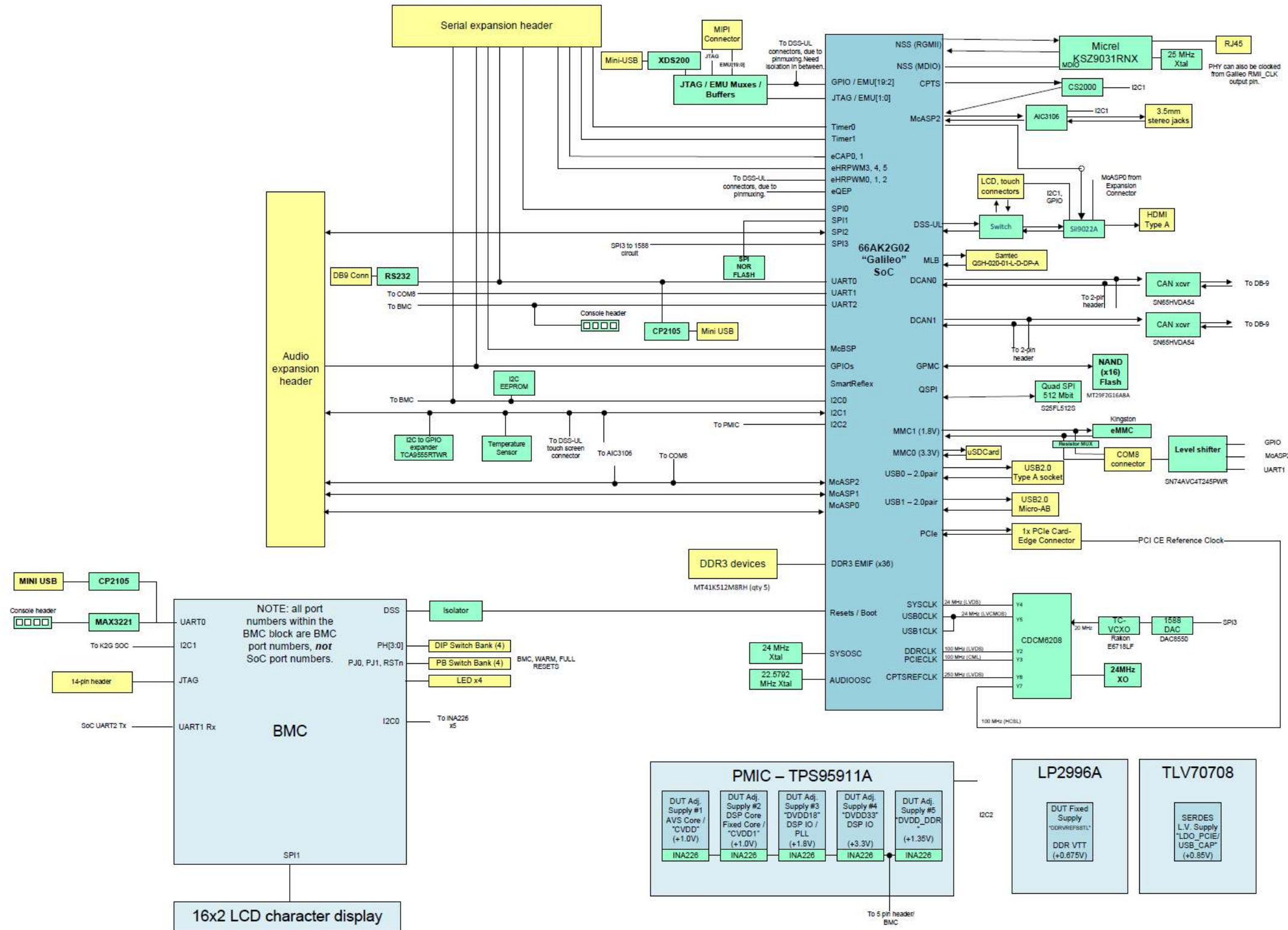

Designed for T1 by Mistral Solutions Pvt Ltd



Title		BLOCK DIAGRAM - K2G EVM	
Size	Variant Name = Proj PROC046 002 OPN# EVMK2GXS	Rev	A
Date:	Friday, February 02, 2018	Sheet	3 of 51

BLOCK DIAGRAM - BMC

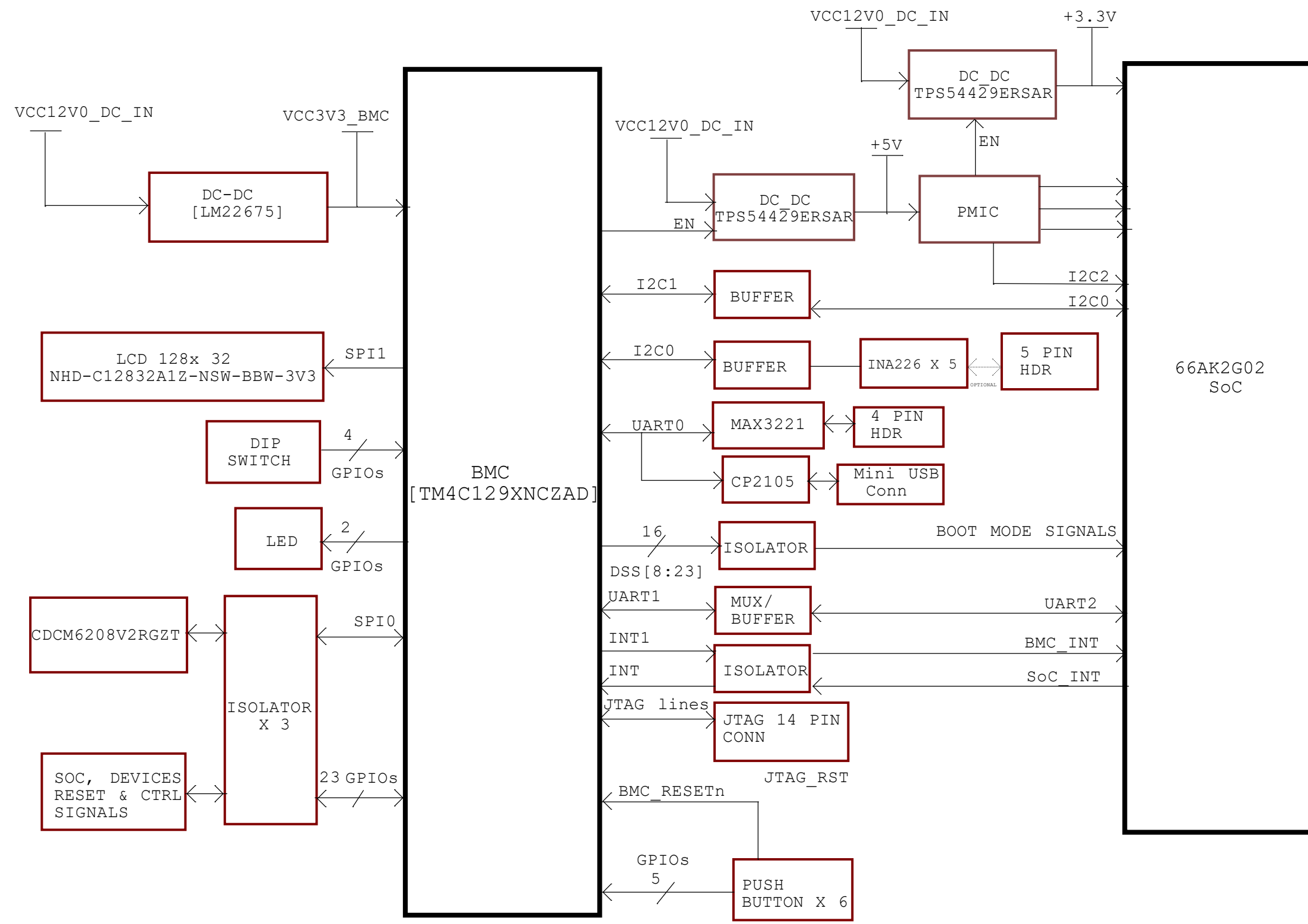

Designed for TI by Mistral Solutions Pvt Ltd



Title BLOCK DIAGRAM - BMC

Size Variant Name = Proj PROC046 002 OPN# EVMK2GXS

Rev

Date: Friday, February 02, 2018 Sheet 4 of 51

BLOCK DIAGRAM - XDS200

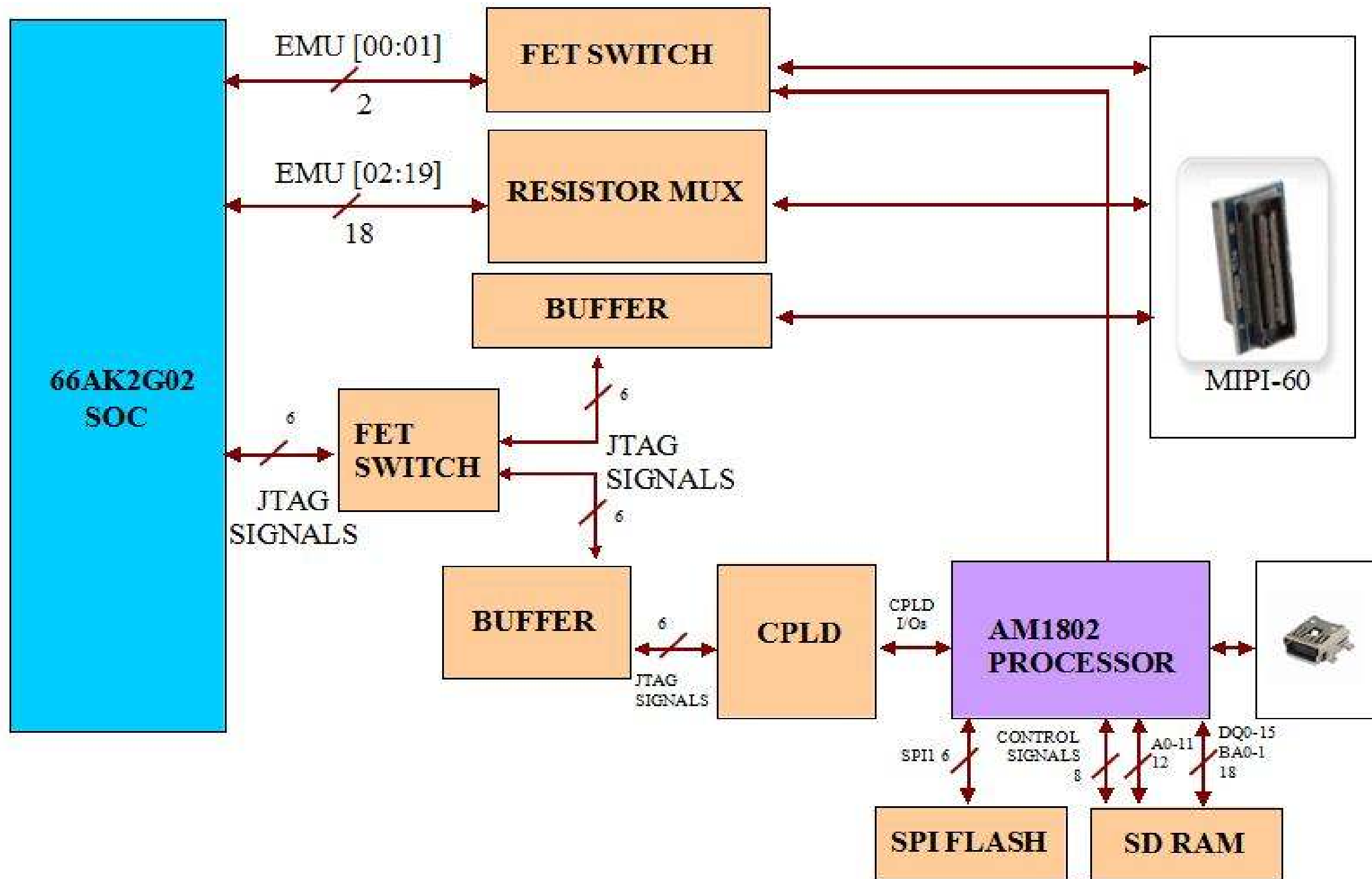

POWER FLOW DIAGRAM

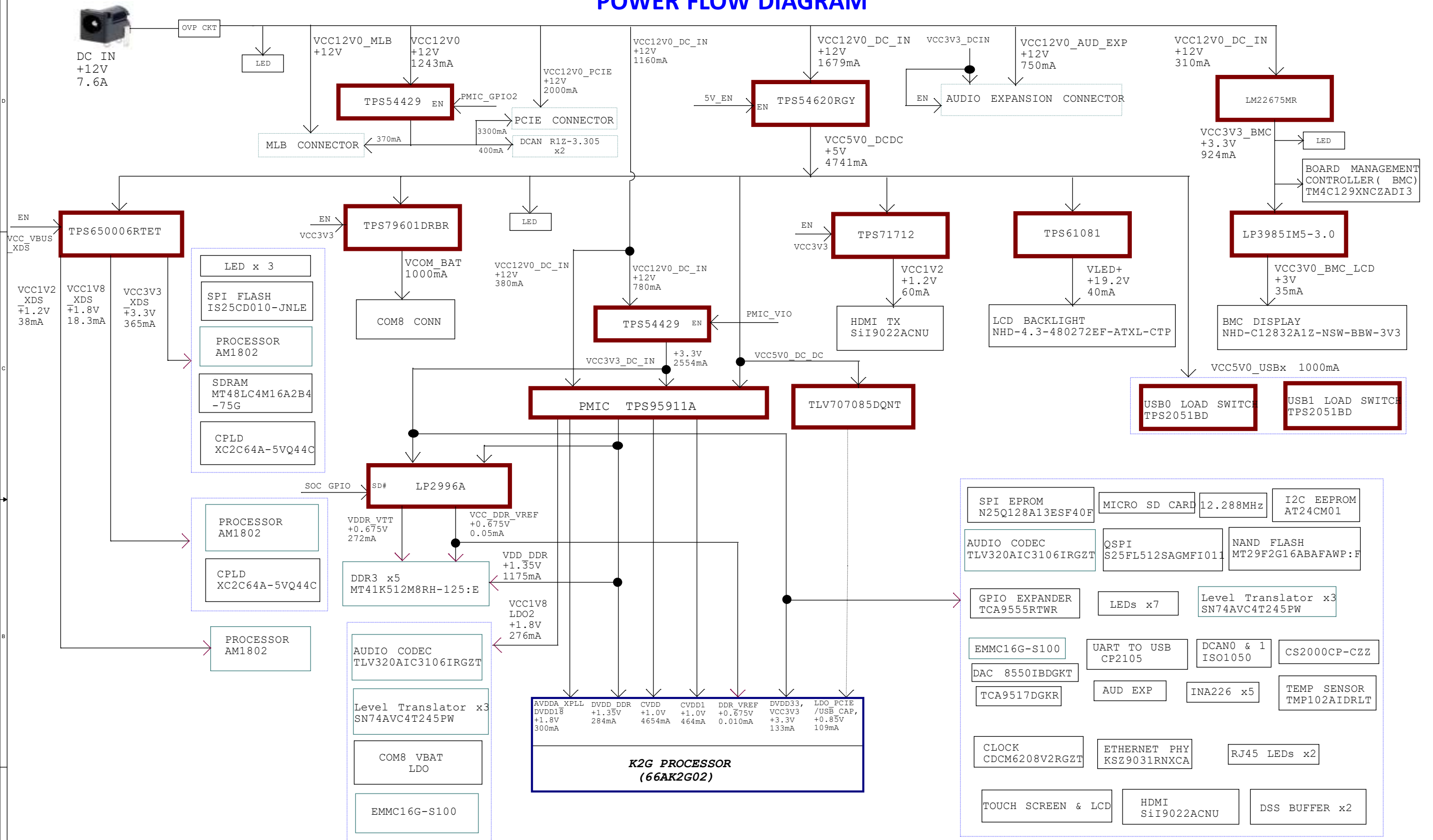

NOTE:

- REGULATORS
- DEVICES
- Multiple powered device

BOARD POWER UP SEQUENCE

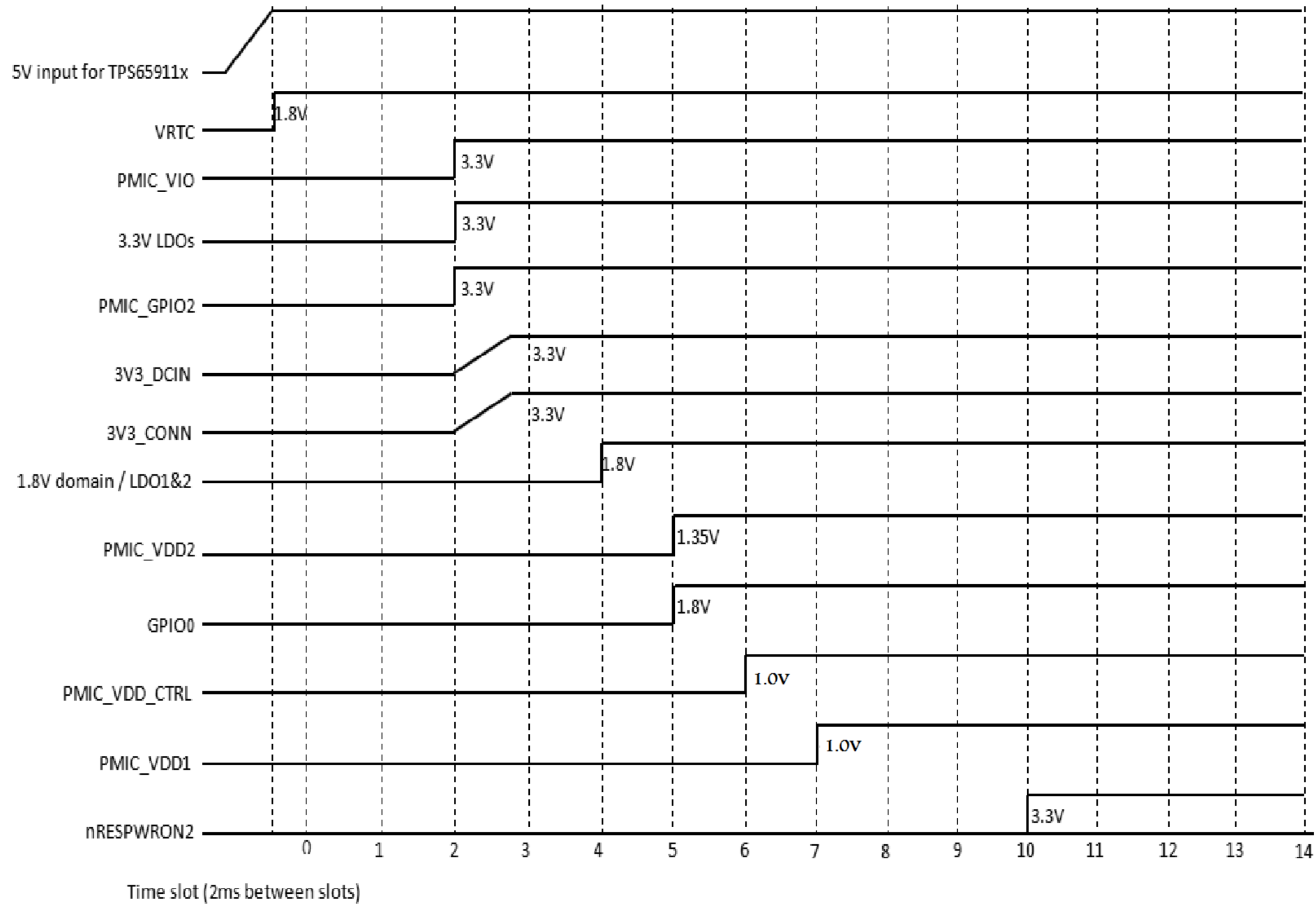

Designed for TI by Mistral Solutions Pvt Ltd



Title BOARD POWER SEQUENCE DIAGRAM

Size	Variant Name = Proj PROC046 002 OPN# EVMK2GXS	Rev
C		A
Date:	Friday, February 02, 2018	Sheet 7 of 51

SoC I2C ADDRESS TABLE

I2C0 DEVICES	7 BIT ADDRESS
EEPROM	0x50 (PAGE 0)
	0x51 (PAGE 1)
BMC	0x0 (PROGRAMMABLE)
SERIAL EXPANSION CONNECTOR	TBD
PCIe CONNECTOR	TBD

I2C2 DEVICES	7 BIT ADDRESS
PMIC	0x2D (GENERAL PURPOSE) TBD
	0x12 (VOLTAGE SCALING) TBD

I2C1 DEVICES	7 BIT ADDRESS
HDMI TRANSMITTER	0x3B
	0x3F
	0x62
AUDIO CODEC	0x1B
TOUCH SCREEN	0x70 (WRITE)
	0x71 (READ)
I/O EXPANDER	0x20
TEMPERATURE SENSOR	0x48
MLB CONNECTOR	TBD
AUDIO EXPANSION CONNECTOR	0x4A, 0x4B, 0x4C, 0x4D
CLOCK GENERATOR (CS2000CP-CZ2)	0x4F

BMC I2C ADDRESS TABLE

BMC I2C0 DEVICES	7 BIT ADDRESS
PMBUS	0x40 : 3.3V
	0x41 : CVDD
	0x42 : CVDD1
	0x43 : 1.8V
	0x44 : DVDD_DDR

BMC I2C1 DEVICES	7 BIT ADDRESS
PROCESSOR	ALWAYS MASTER

McASP CONFIGURATION

McASP PORT	DEVICES	DEVICE MODE
McASP0	DAC- PCM1690 x2	SLAVE
	I2S HEADER	MASTER
McASP1	ADC- PCM1865 x2	SLAVE
McASP2	HDMI TRANSMITTER (DEFAULT)	SLAVE
	AUDIO CODEC AIC3106	
	DIR9001 (DEFAULT)	MASTER
	COM8	

Designed for TI by Mistral Solutions Pvt Ltd



Title I2C TREE

Size	Variant Name = Proj PROC046 002 OPN# EVMK2GXS	Rev
C		A
Date:	Friday, February 02, 2018	Sheet 8 of 51

McASP DISTRIBUTION DIAGRAM

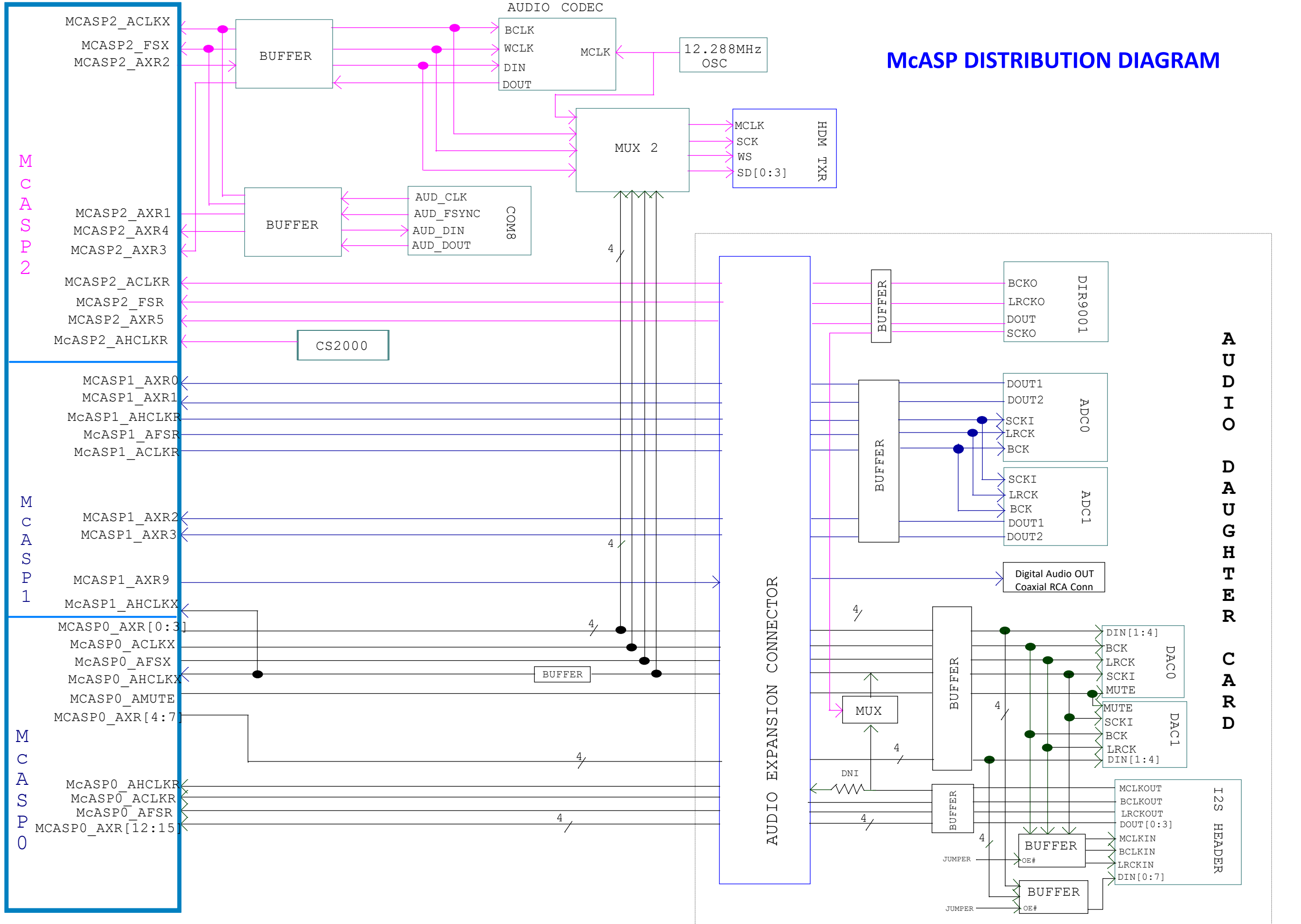

Designed for T1 by Mistral Solutions Pvt Ltd



Title MCASP TREE

Size	Variant Name = Proj PROC046 002 OPN# EVMK2GXS	Rev
C		A
Date:	Friday, February 02, 2018	Sheet 9 of 51

SoC RESET

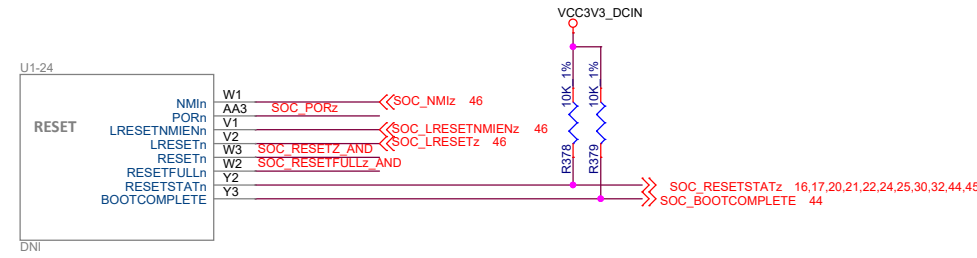

POWER ON RESET

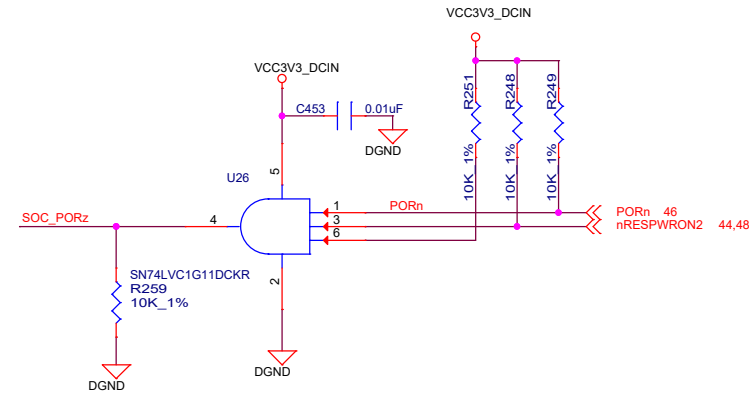

FULL RESET

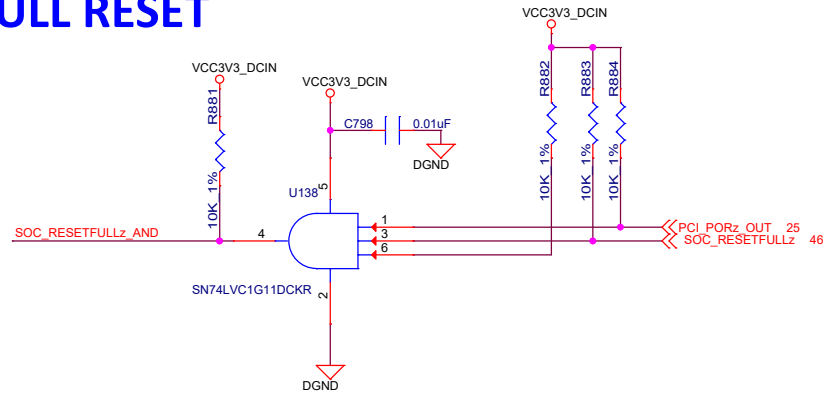

WARM RESET

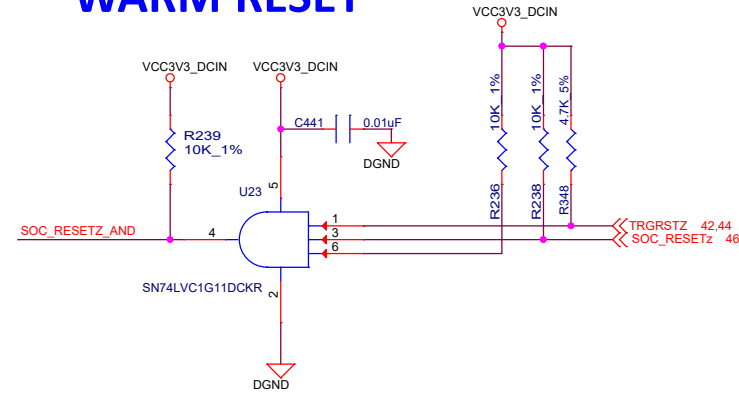

SoC CLOCK

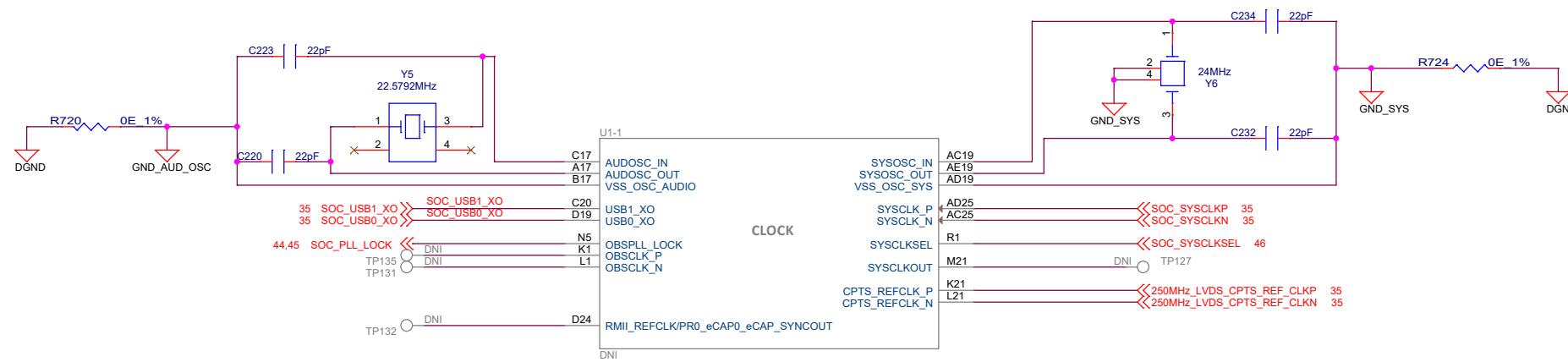

Designed for T1 by Mistral Solutions Pvt Ltd



Title SOC CLOCK & RESET

Size	Variant Name = Proj PROC046 002 OPN# EVMK2GXS	Rev	A
Date:	Friday, February 02, 2018	Sheet	10 of 51

SoC GPIOs

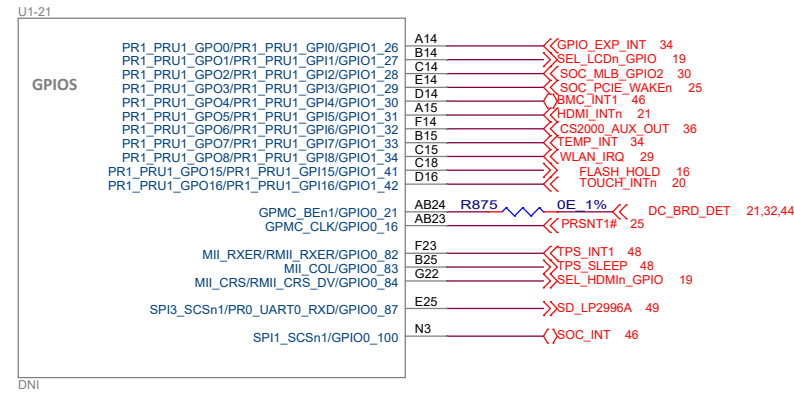

RESERVED PINS

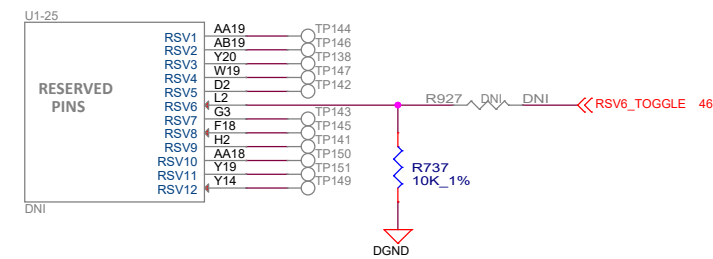
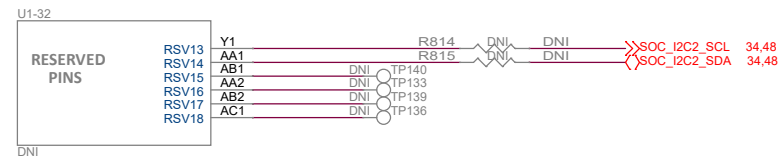

Designed for T1 by Mistral Solutions Pvt Ltd



Title SOC GPIO, SMART REFLEX & TEST OUT

Size	Variant Name = Proj PROC046 002 OPN# EVMK2GXS	Rev
C		A
Date:	Friday, February 02, 2018	Sheet 11 of 51

VPP POWER GENERATION

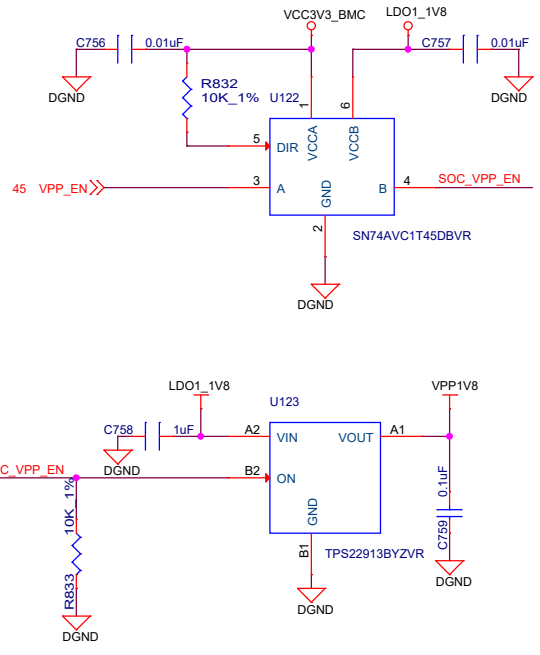

SoC POWER -CVDD,CVDD1

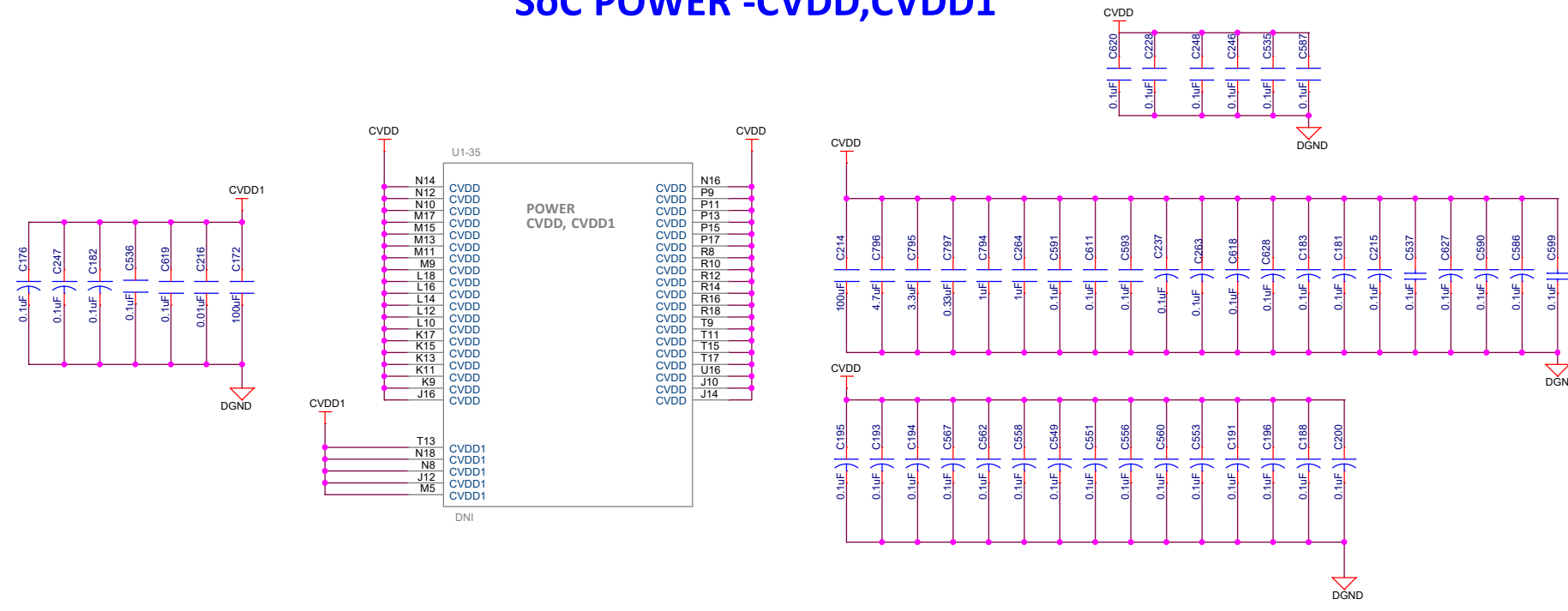

SoC POWER - PLL

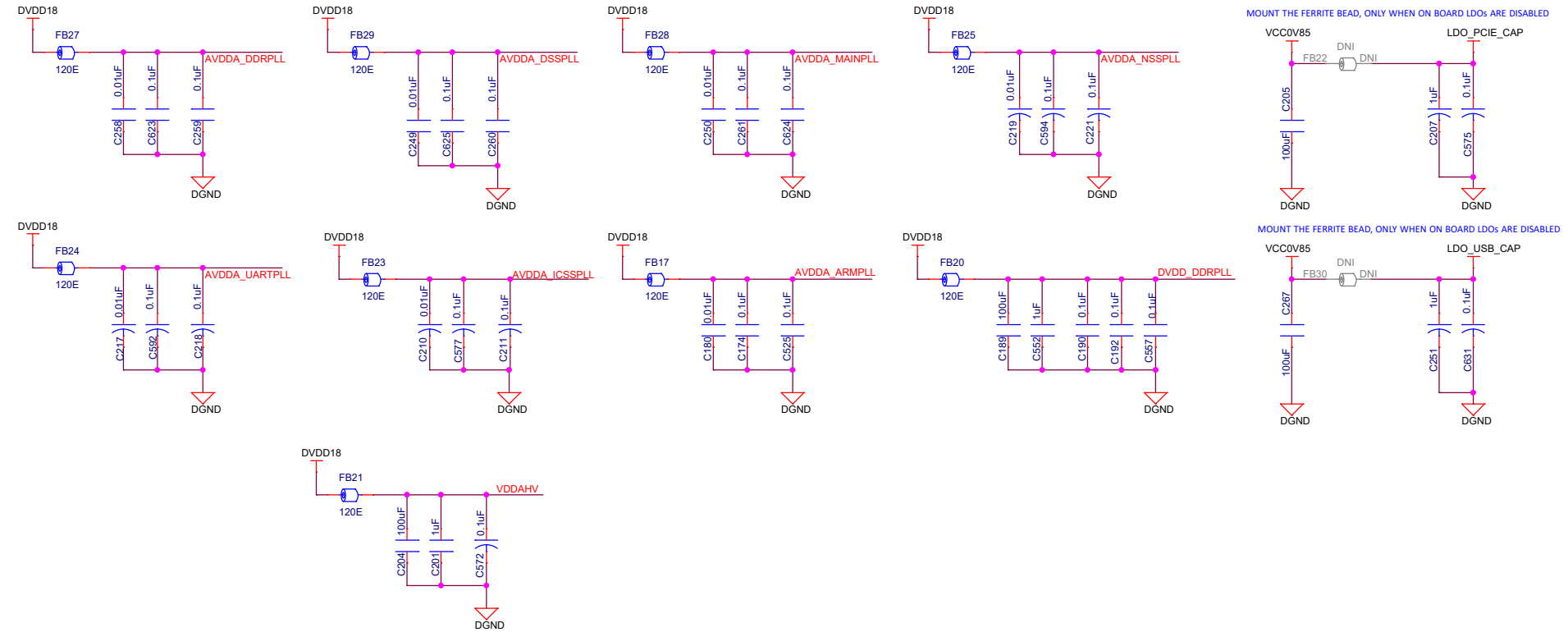
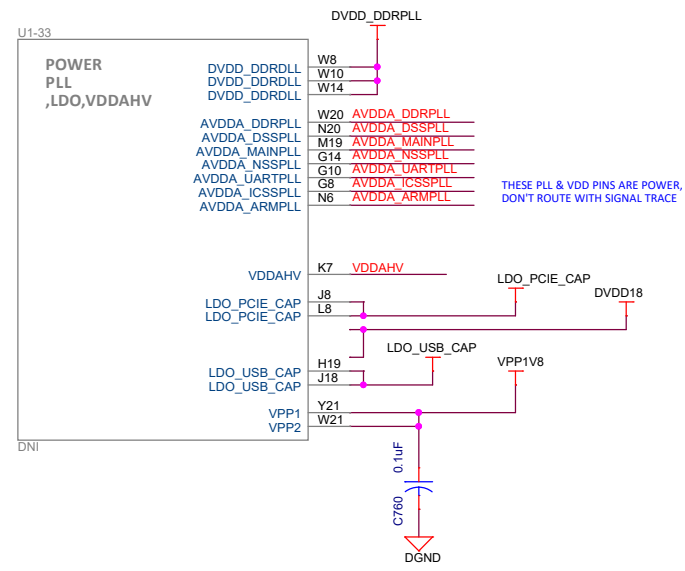

Designed for T1 by Mistral Solutions Pvt Ltd



Title		SOC POWER - CVDD,CVDD1 & PLL	
Size	Variant Name = Proj PROC046 002 OPN# EVMK2GX5	Rev	A
Date:	Friday, February 02, 2018	Sheet	12 of 51

SoC POWER - DVDD33

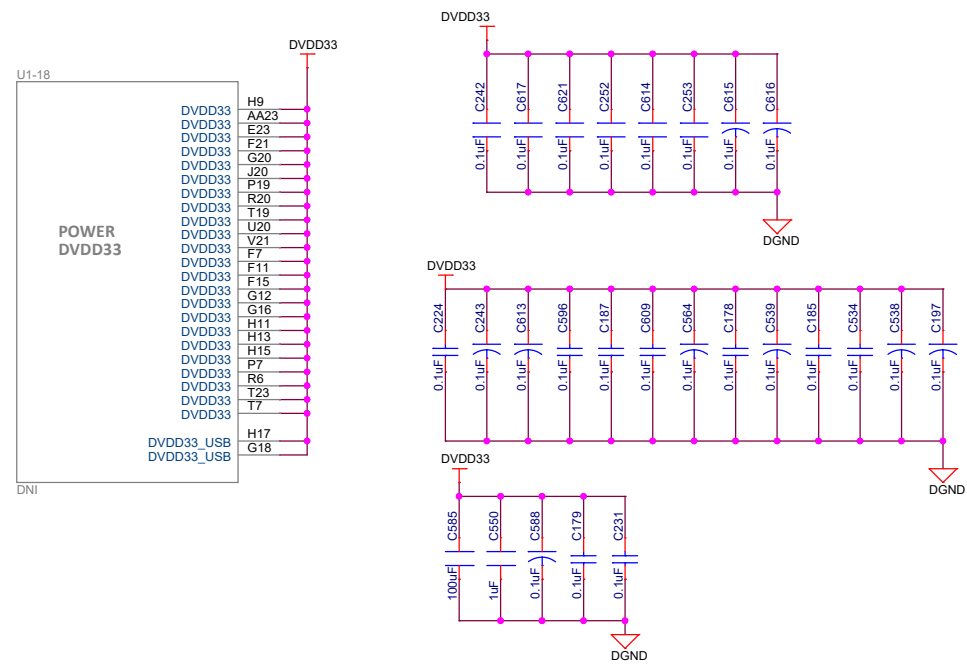

SoC POWER - DVDD18, DVDD_DDR

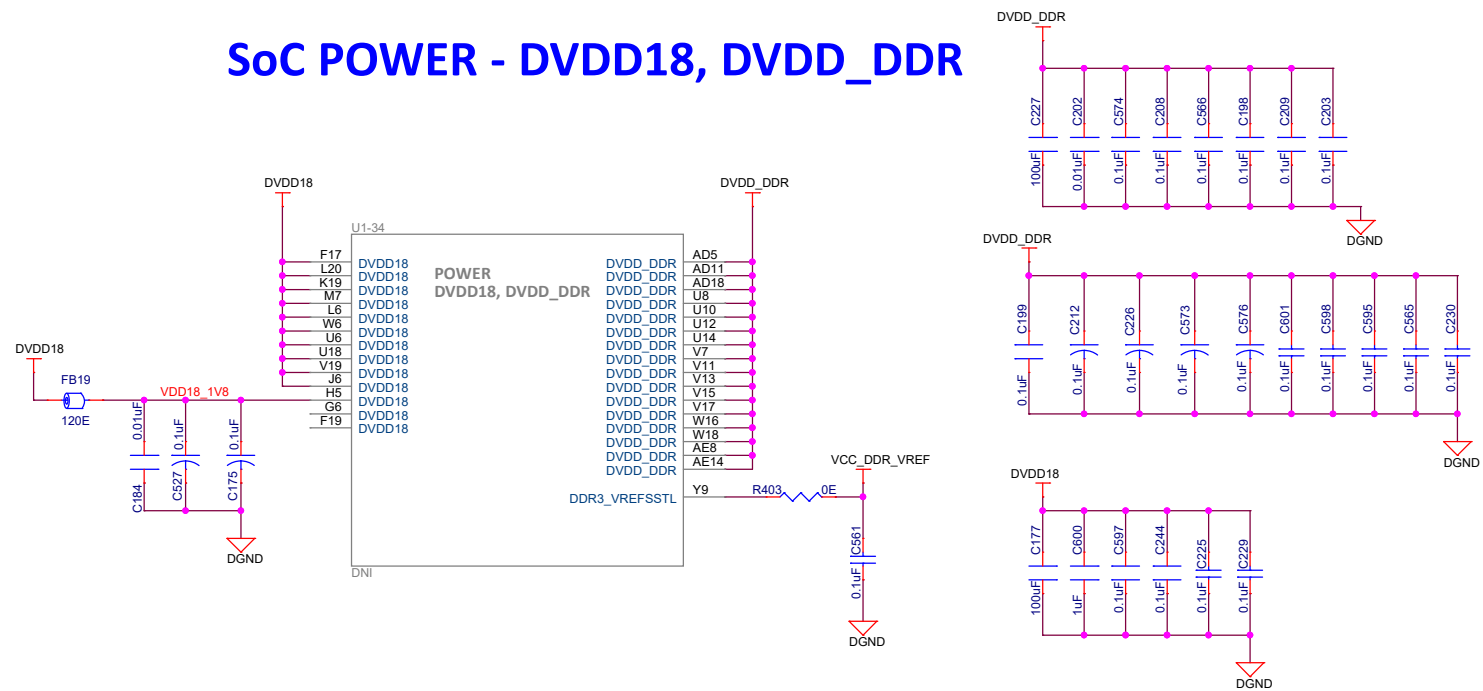

SoC POWER - VSS

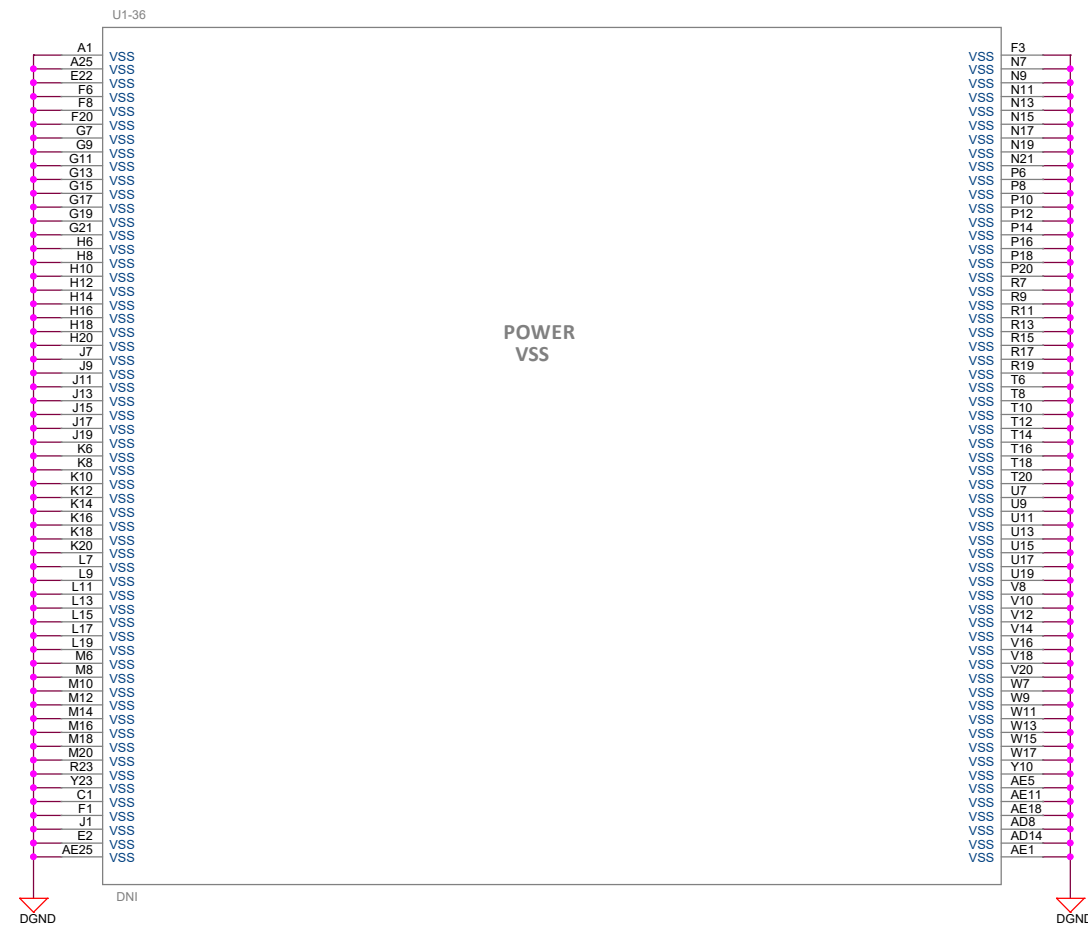

Designed for T1 by Mistral Solutions Pvt Ltd



Title: SOC POWER - DVDD33, DVDD18, DVDD_DDR & VSS

Size	Variant Name = Proj PROC046 002 OPN# EVMK2GXS	Rev
C		A
Date:	Friday, February 02, 2018	Sheet 13 of 51

DDR DEVICE1

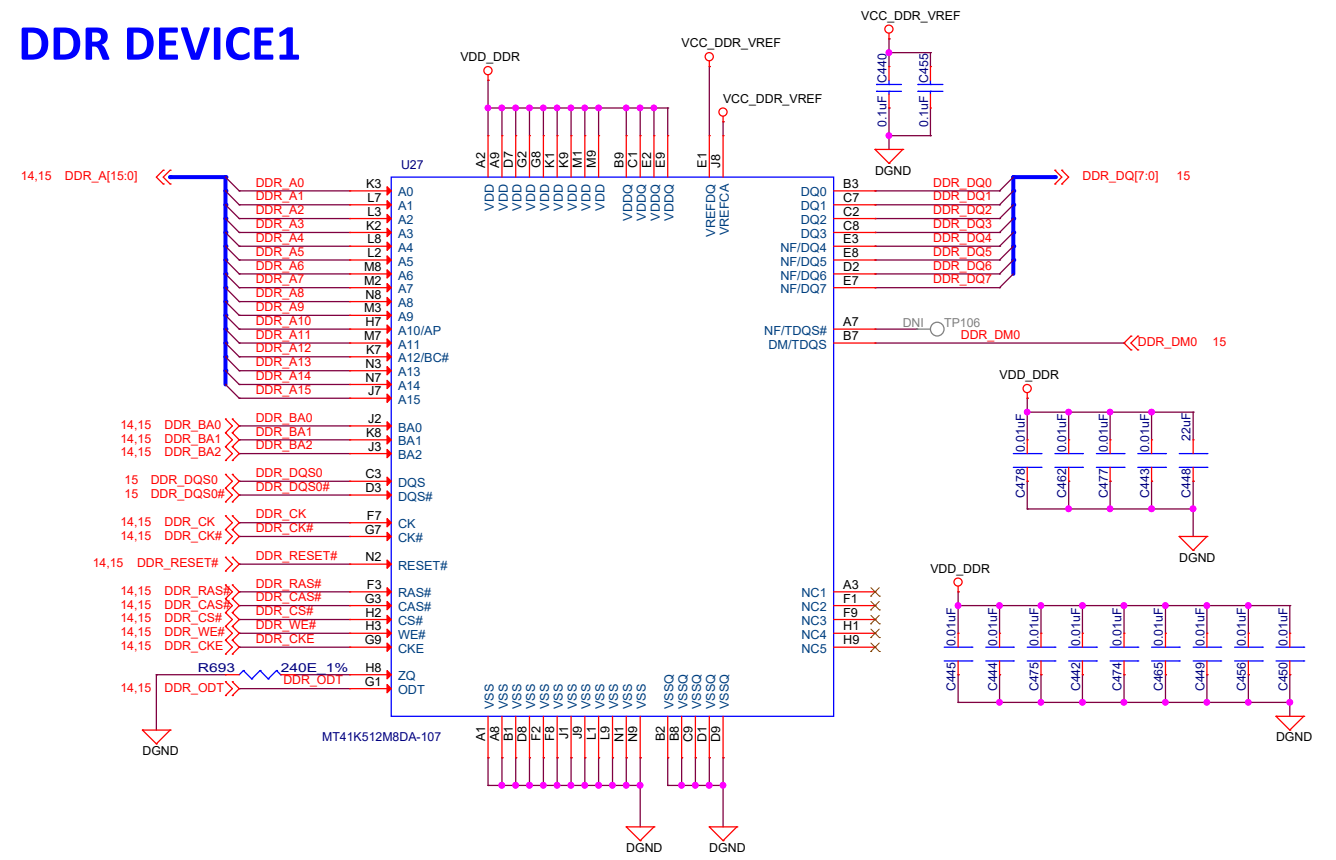

DDR DEVICE2

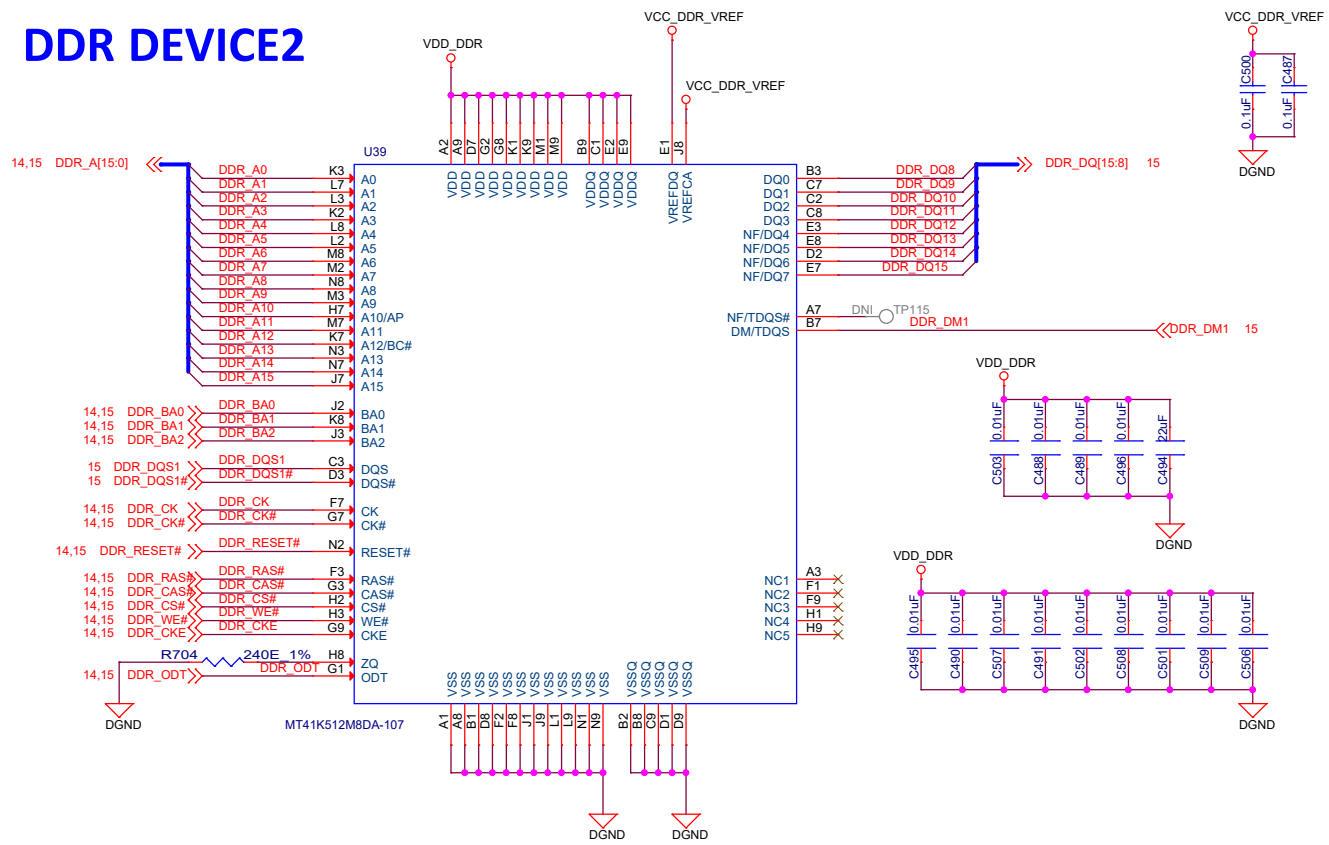

DDR DEVICE4

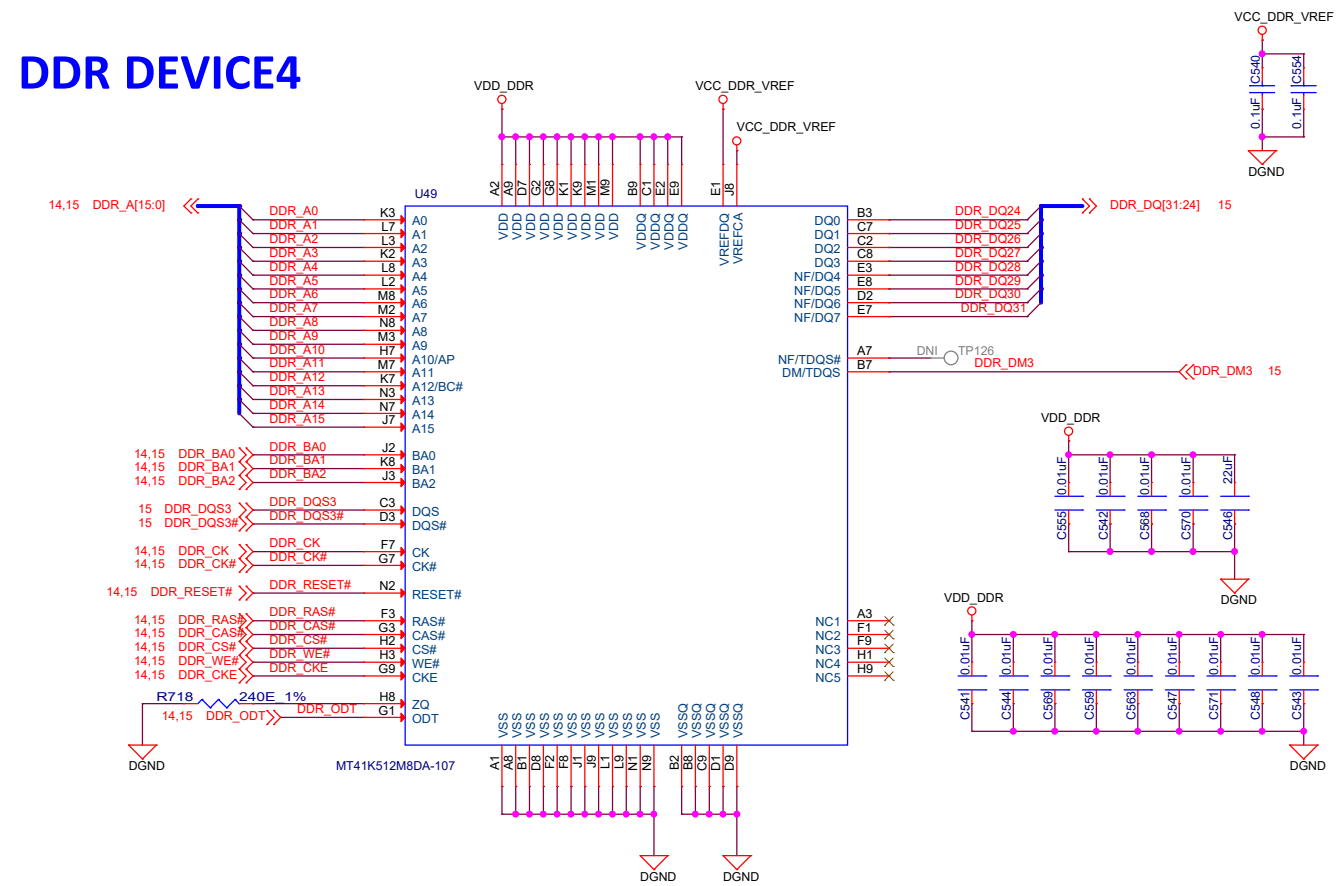

DDR DEVICE3

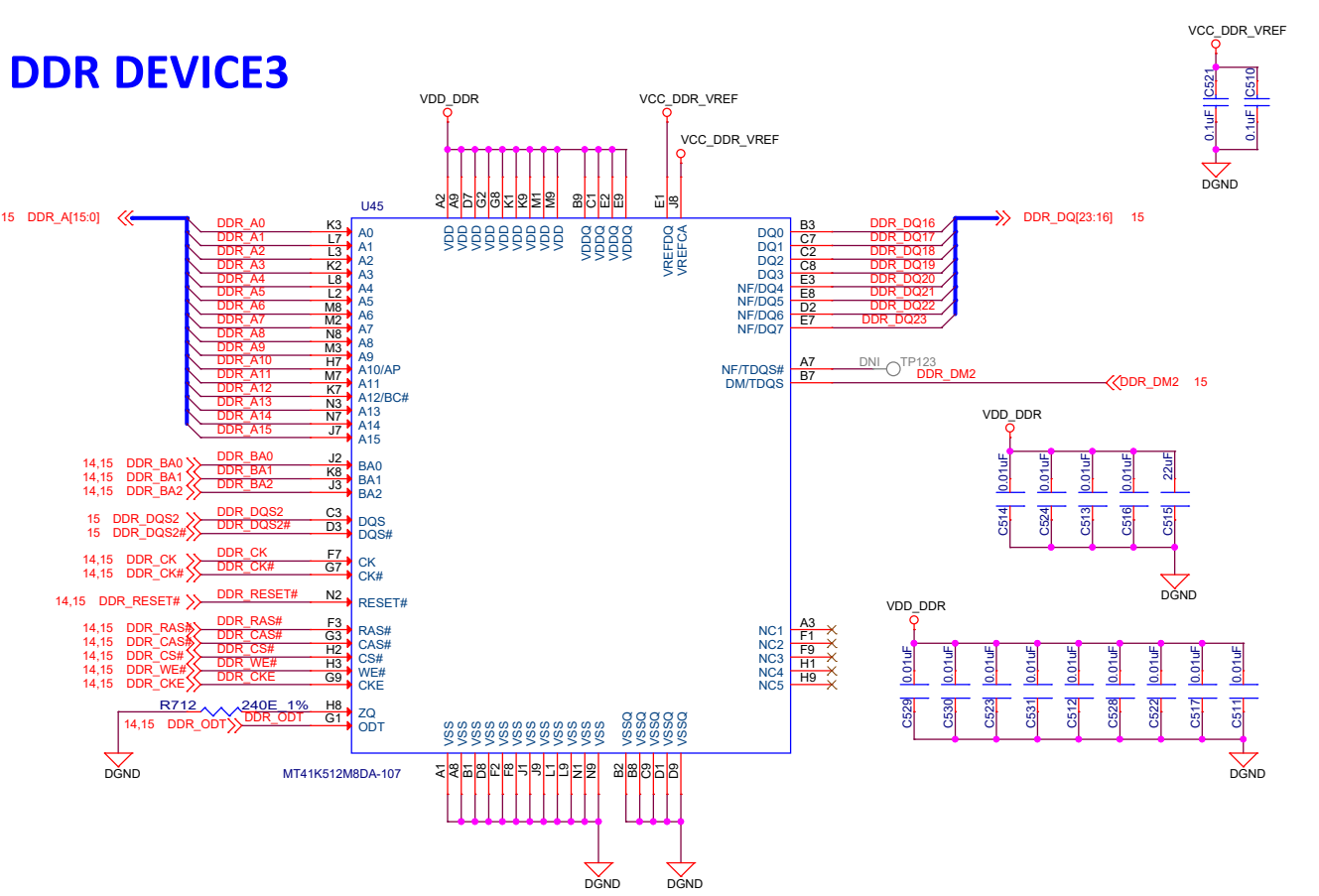

Designed for T1 by Mistral Solutions Pvt Ltd



Title		DDR3L DEVICES	
Size	Variant Name = Proj PROC046 002 OUP# EVMK2GX5	Rev	A
Date:	Friday, February 02, 2018	Sheet	14 of 51

SoC DDR INTERFACE

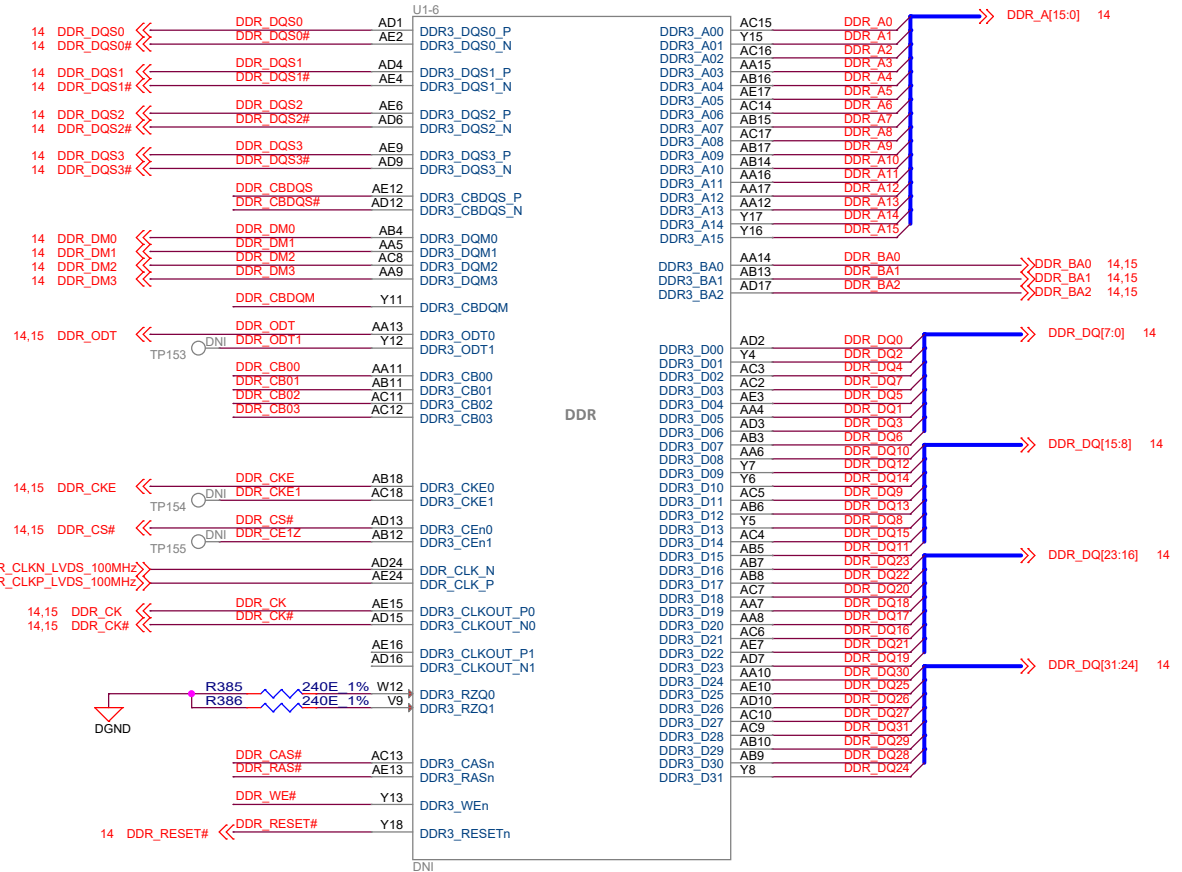
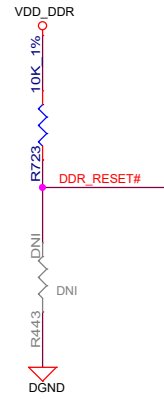

ECC DEVICE

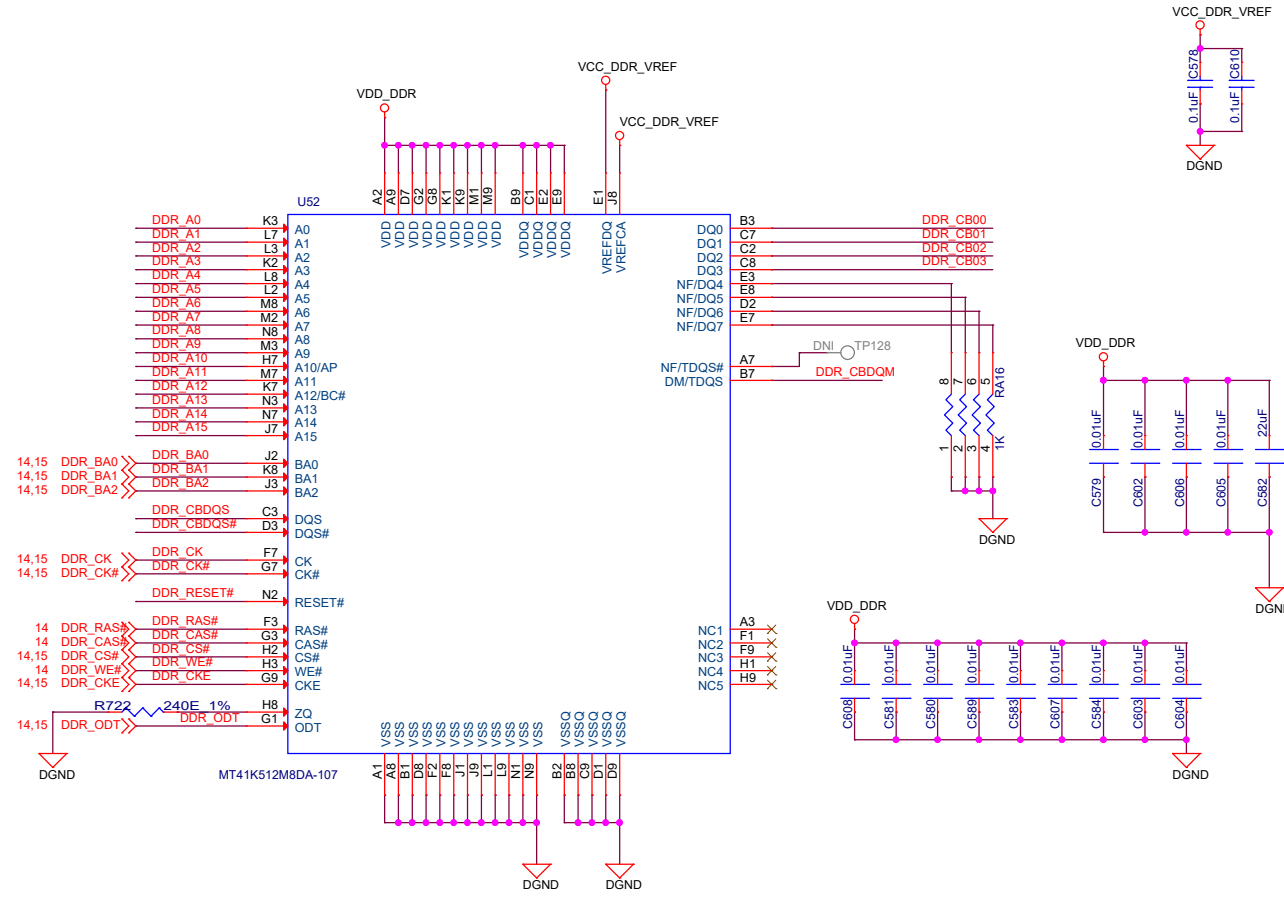

DDR TERMINATION

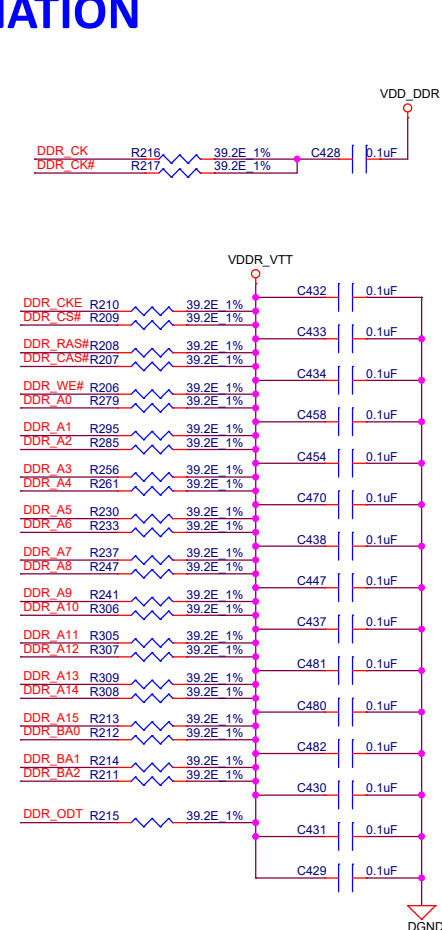

Designed for T1 by Mistral Solutions Pvt Ltd



Title: SOC DDR MODULE, ECC & TERMINATION

Size	Variant Name = Proj PROC046 002 OPN# EVMK2GX5	Rev
C		A
Date:	Friday, February 02, 2018	Sheet 15 of 51

QSPI

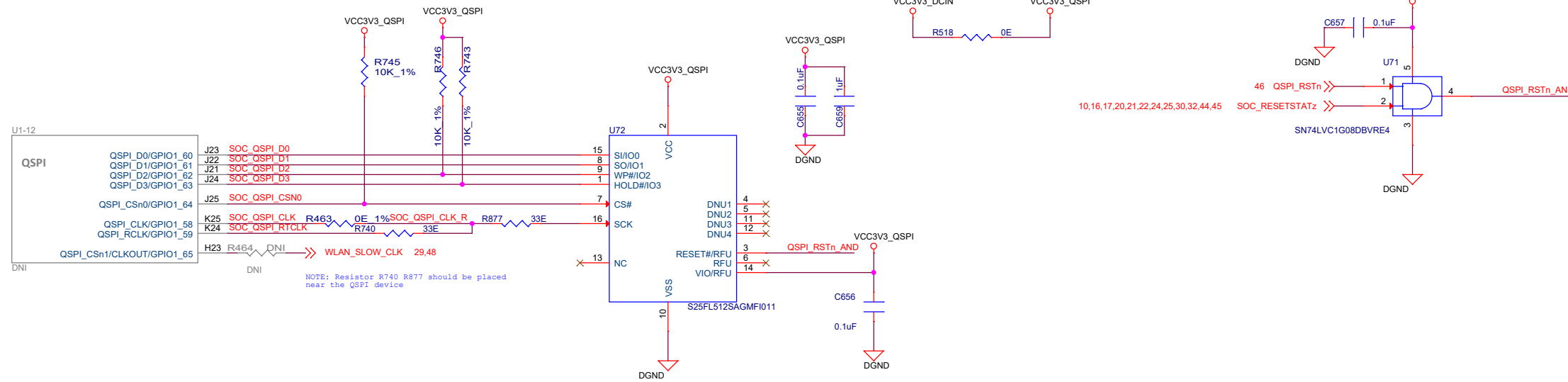

I2C EEPROM FLASH

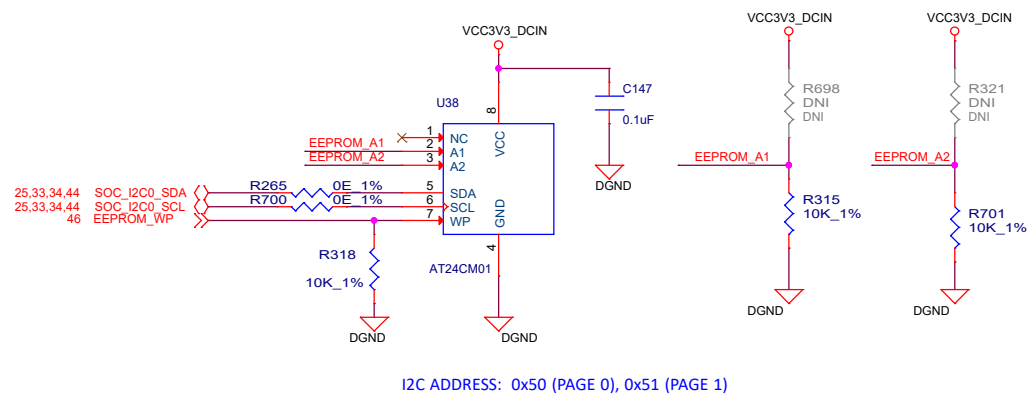

SPI NORFLASH

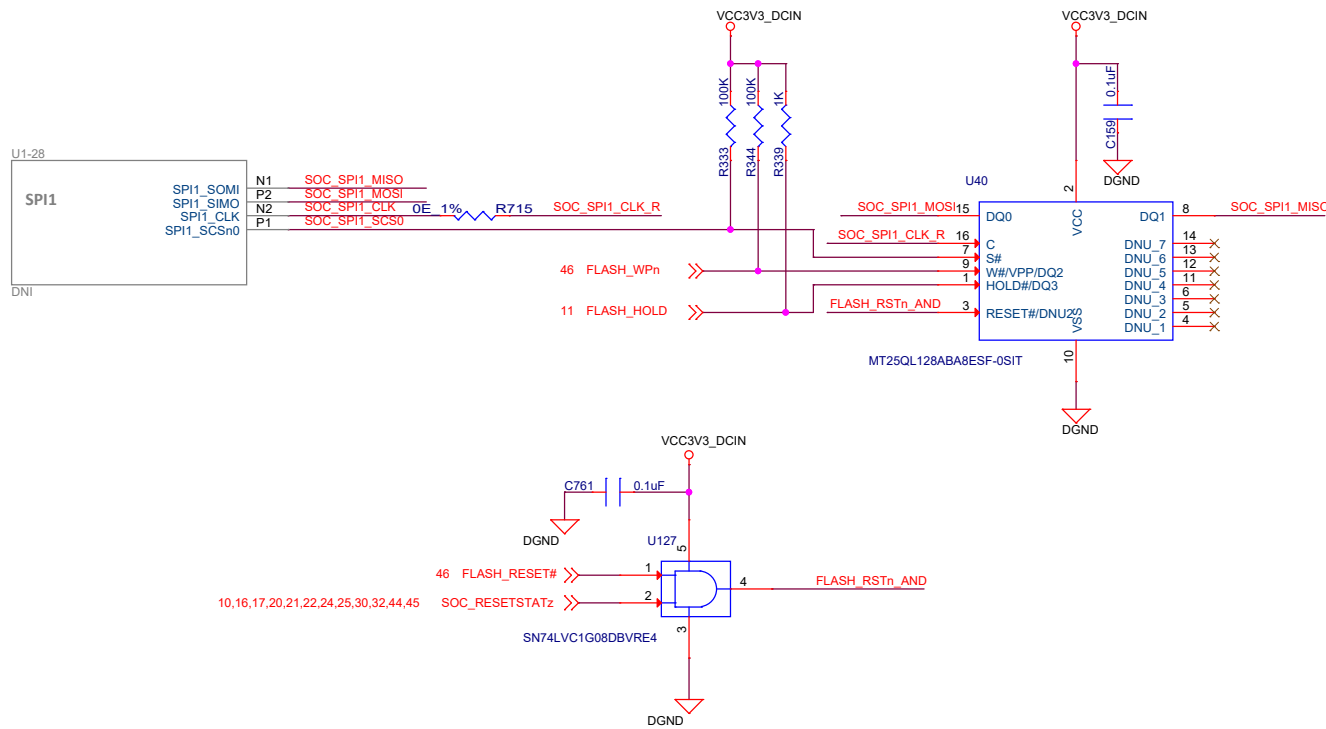

eMMC FLASH

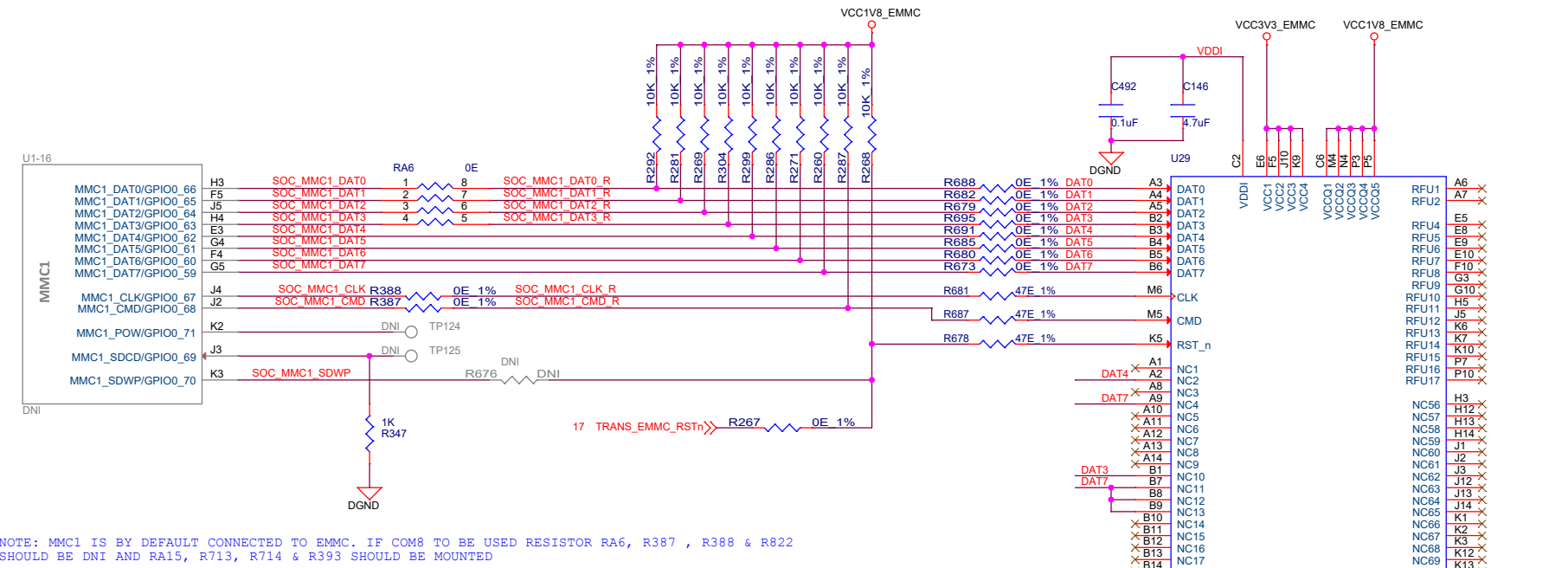
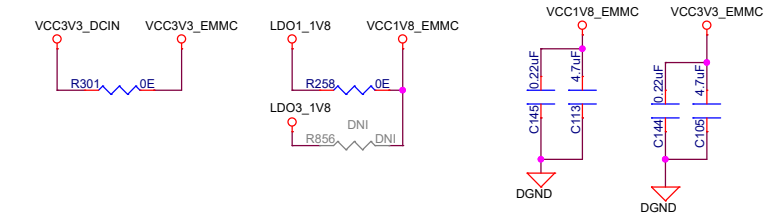

NOTE: MMC1 IS BY DEFAULT CONNECTED TO EMMC. IF COM8 TO BE USED RESISTOR RA6, R387, R388 & R822 SHOULD BE DNI AND RA15, R713, R714 & R393 SHOULD BE MOUNTED

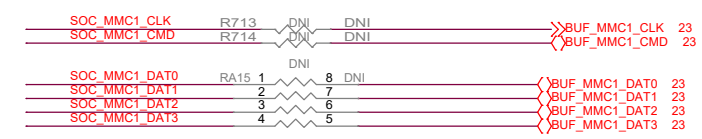

eMMC RESET

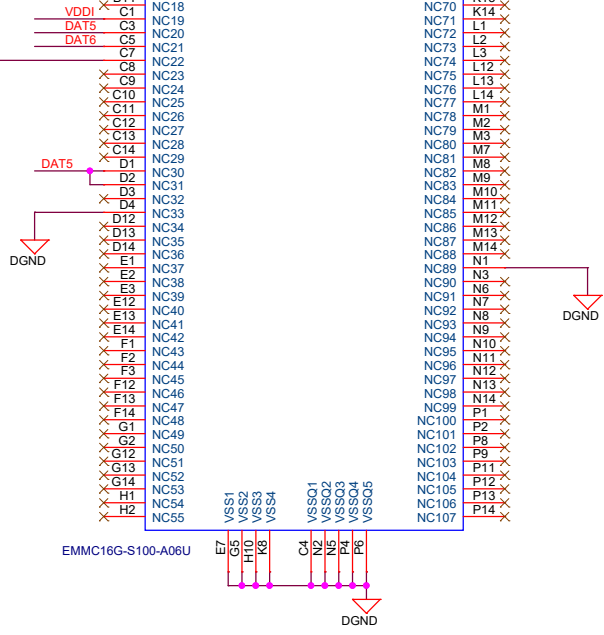
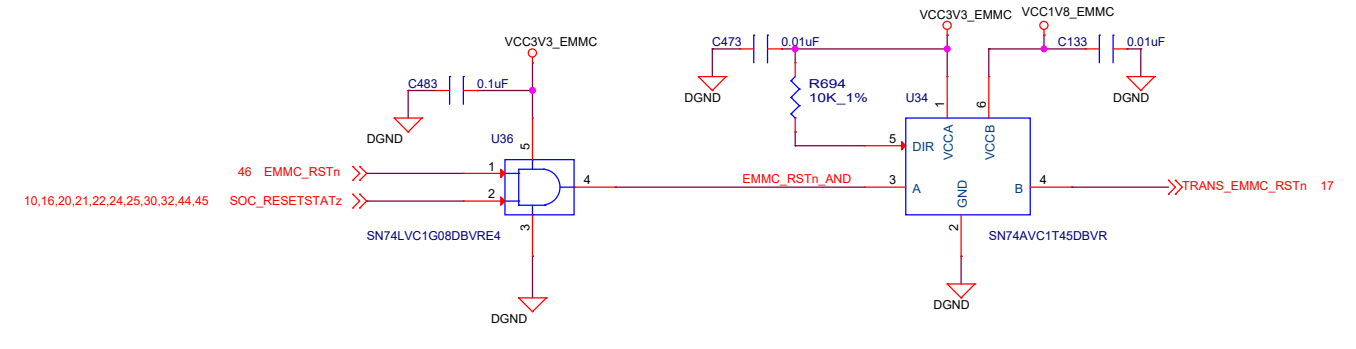

Note: NC pins are connected to eMMC Signals for routing

Designed for T1 by Mistral Solutions Pvt Ltd



Title		EMMC FLASH	
Size	Variant Name = Proj PROC046 002 OPN# EVMK2GXS	Rev	
C		A	
Date:	Friday, February 02, 2018	Sheet	17 of 51

NAND Flash

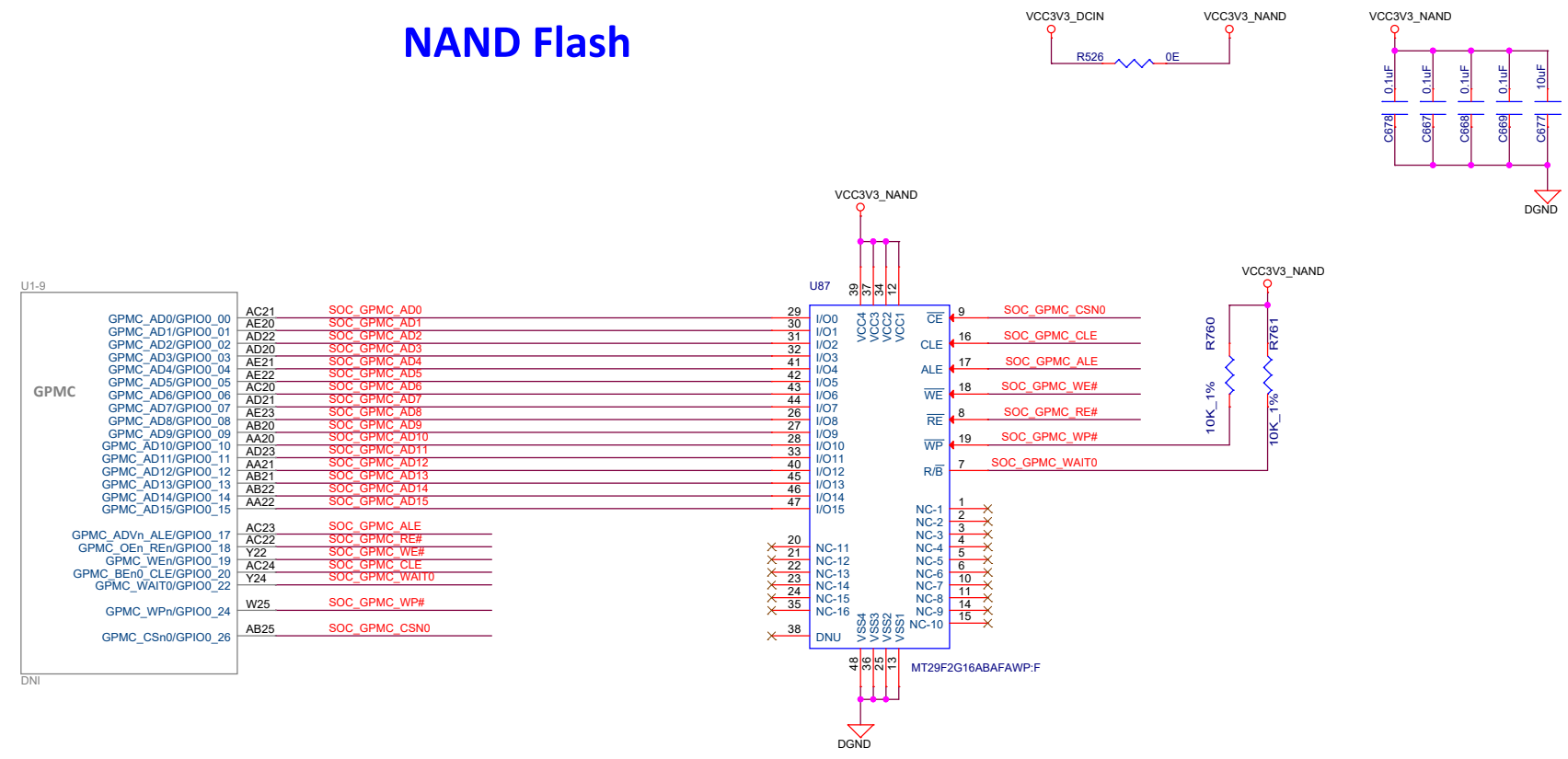

MICRO SD CARD

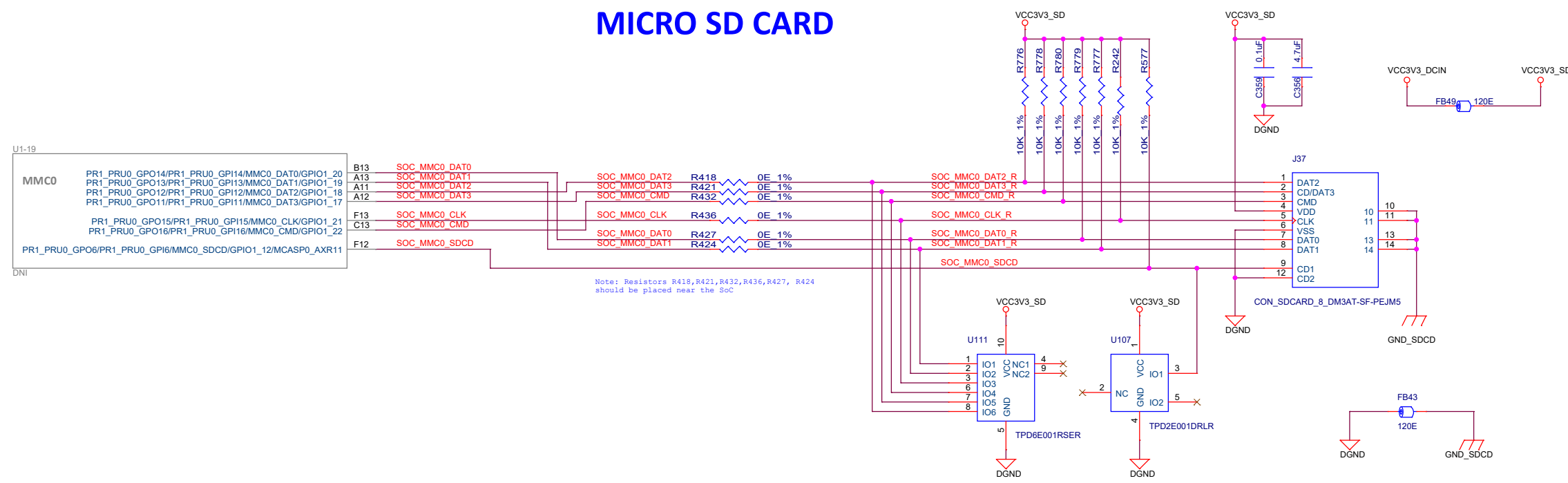

DSS BUFFER 1

DSS BUFFER 2

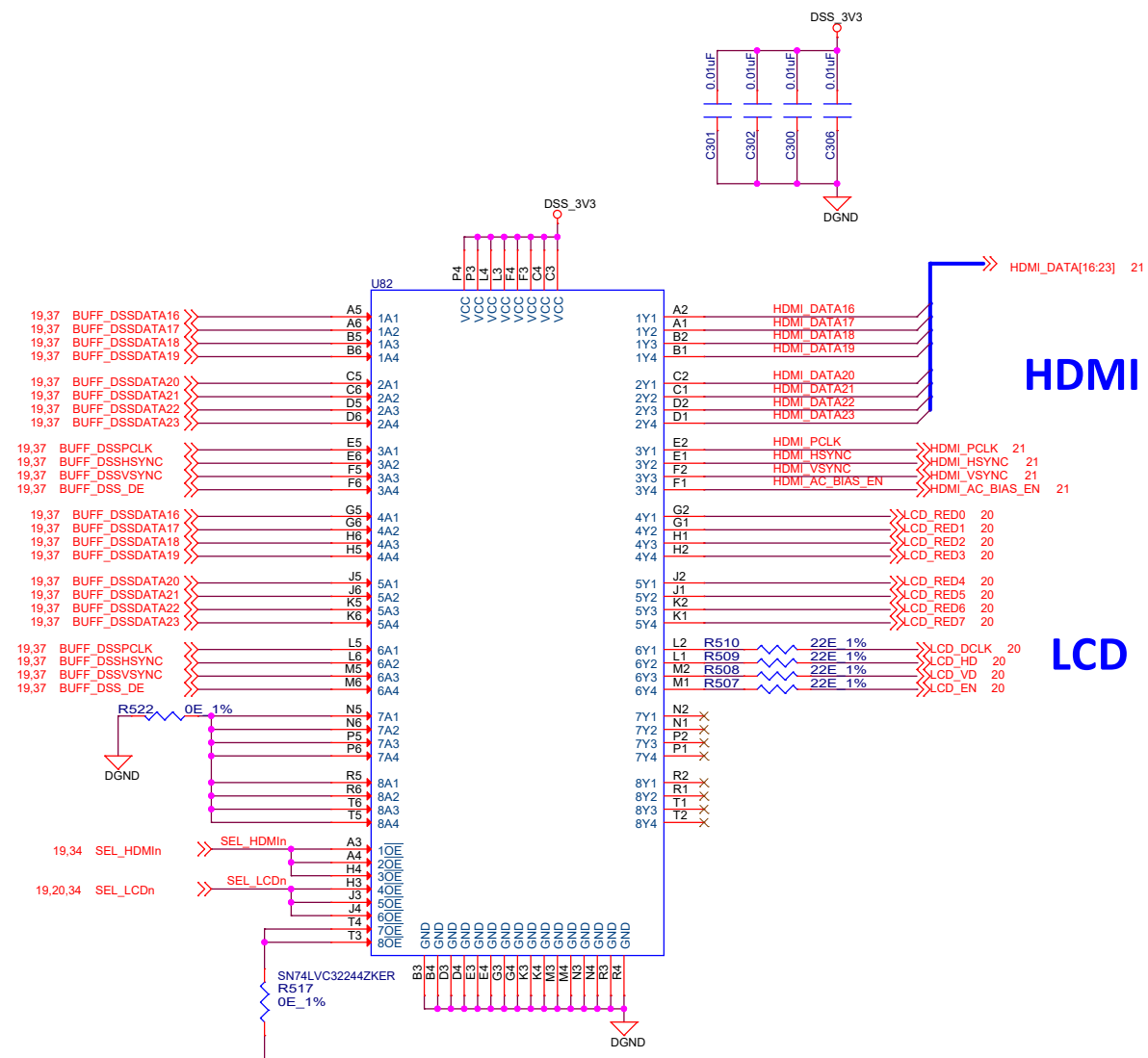
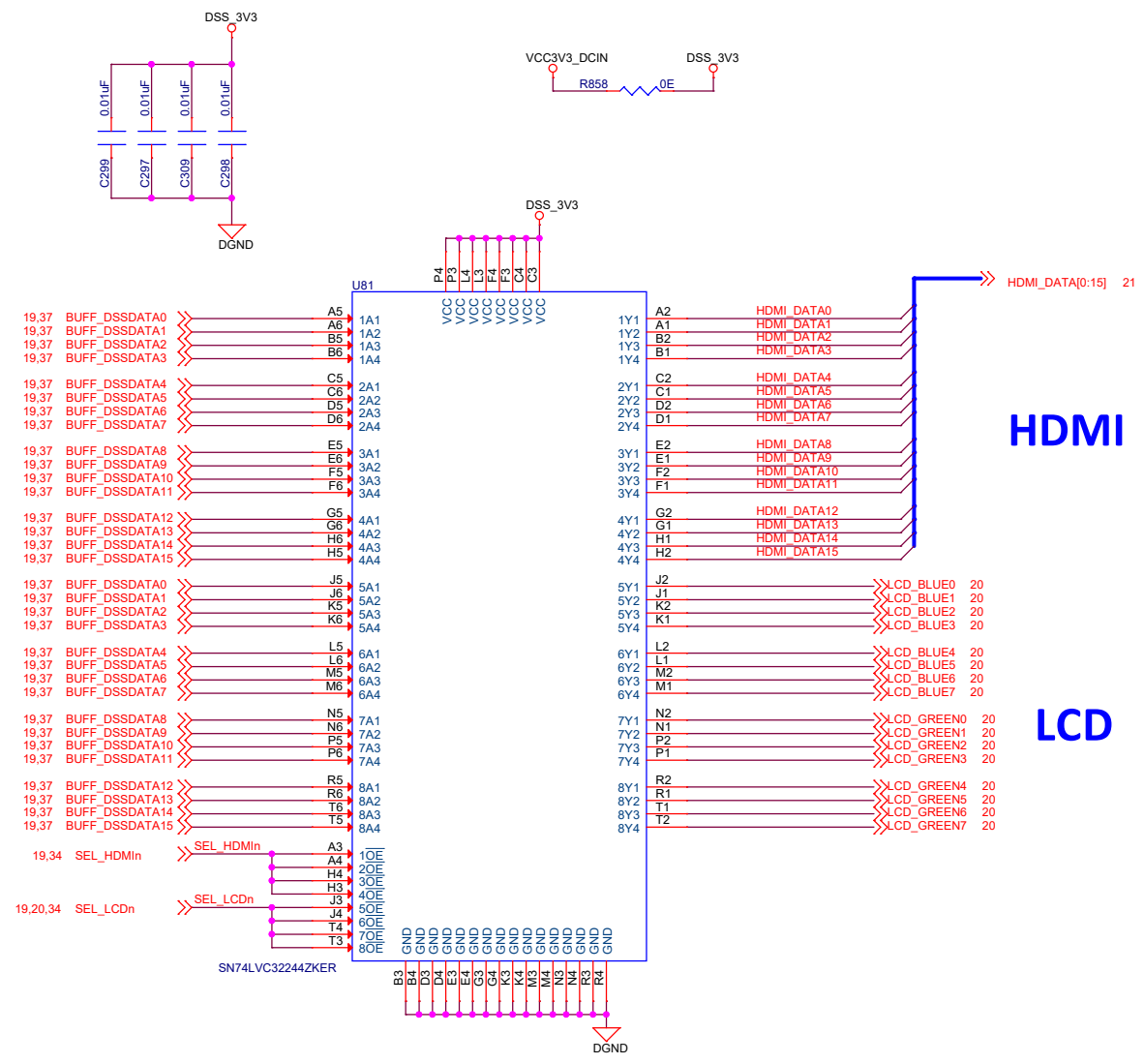

SELECTION LCD AND HDMI

HDMI/LCD SWITCH SELECTION

SW14	SW13	DEVICE
ON	ON	HDMI ON
OFF	OFF	LCD ON
OFF	ON	NOT VALID
ON	OFF	NOT VALID

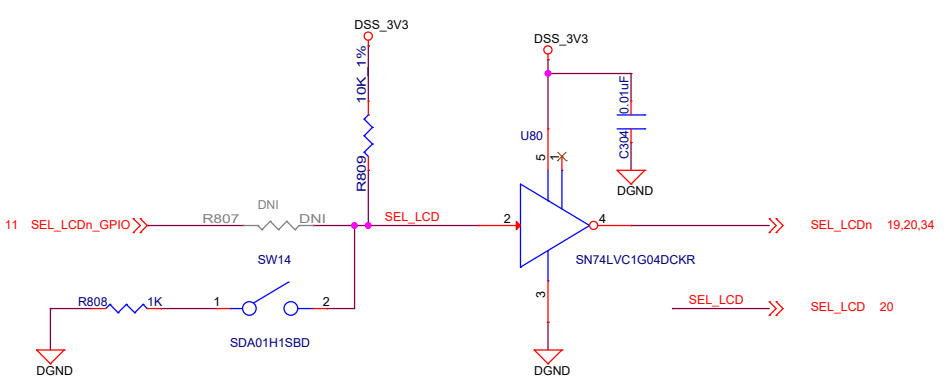
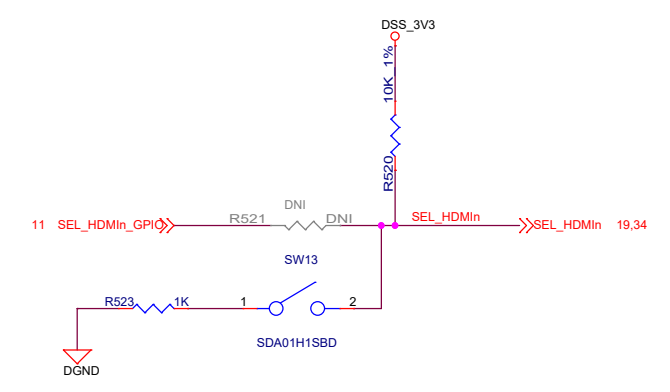

Designed for T1 by Mistral Solutions Pvt Ltd



Title		DSS BUFFER SECTION	
Size	Variant Name = Proj PROC046 002 OPN# EVMK2GXS	Rev	A
Date:	Friday, February 02, 2018	Sheet	19 of 51

TOUCH SCREEN CONNECTOR

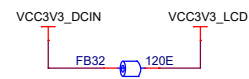
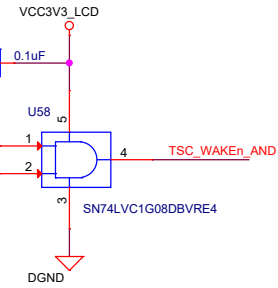
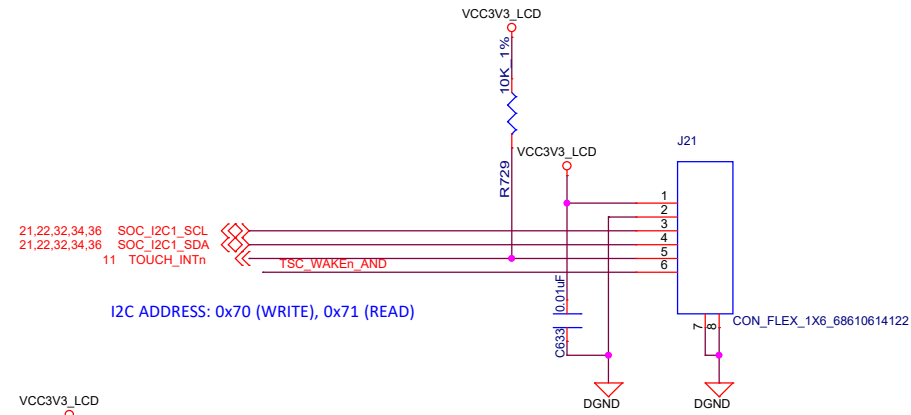

LCD CONNECTOR

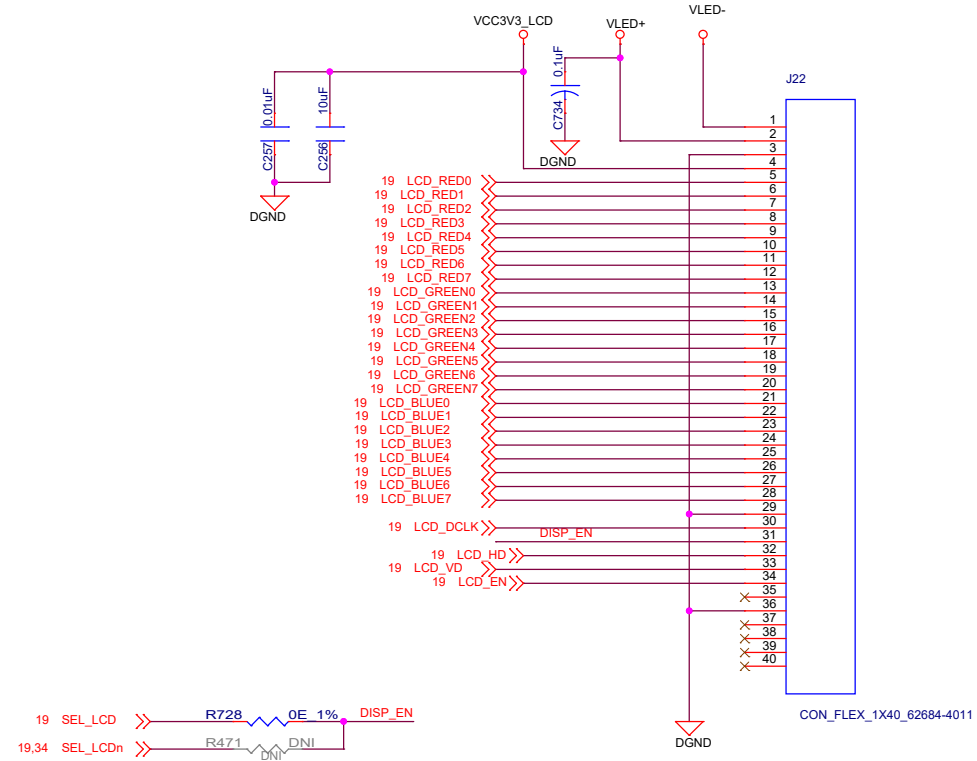

SOC DSS

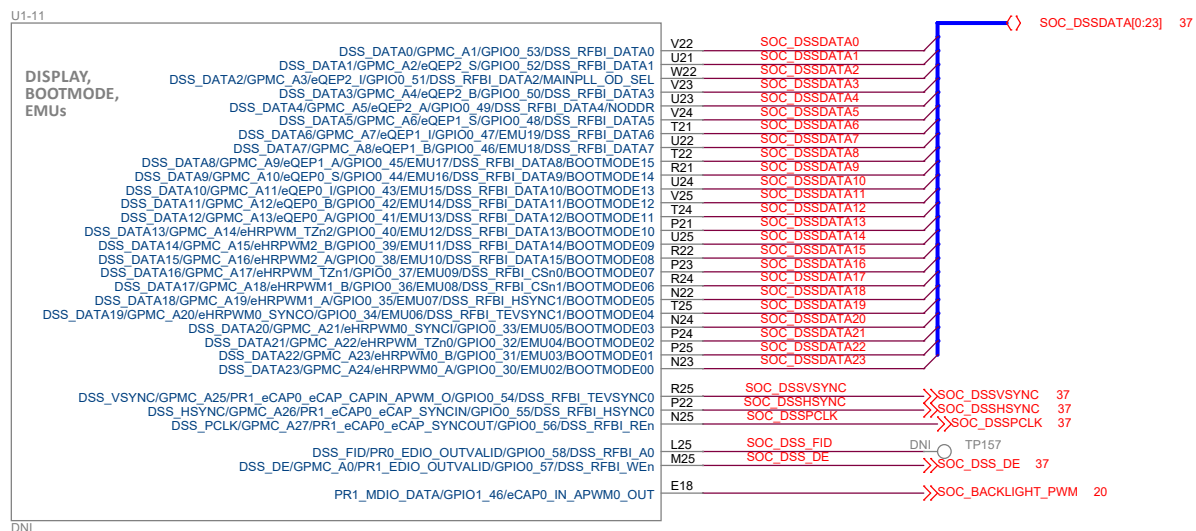

BACKLIGHT POWER

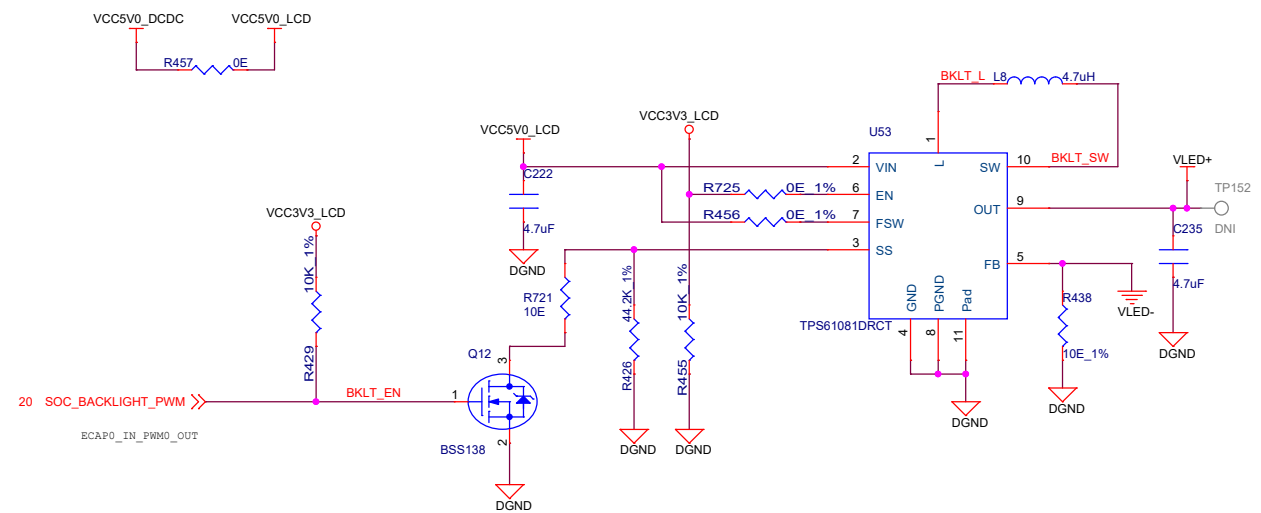

Designed for T1 by Mistral Solutions Pvt Ltd



Title LCD & TOUCH SCREEN

Size	Variant Name = Proj PROC046 002 OUN# EVMK2GXS	Rev
C		A
Date:	Friday, February 02, 2018	Sheet 20 of 51

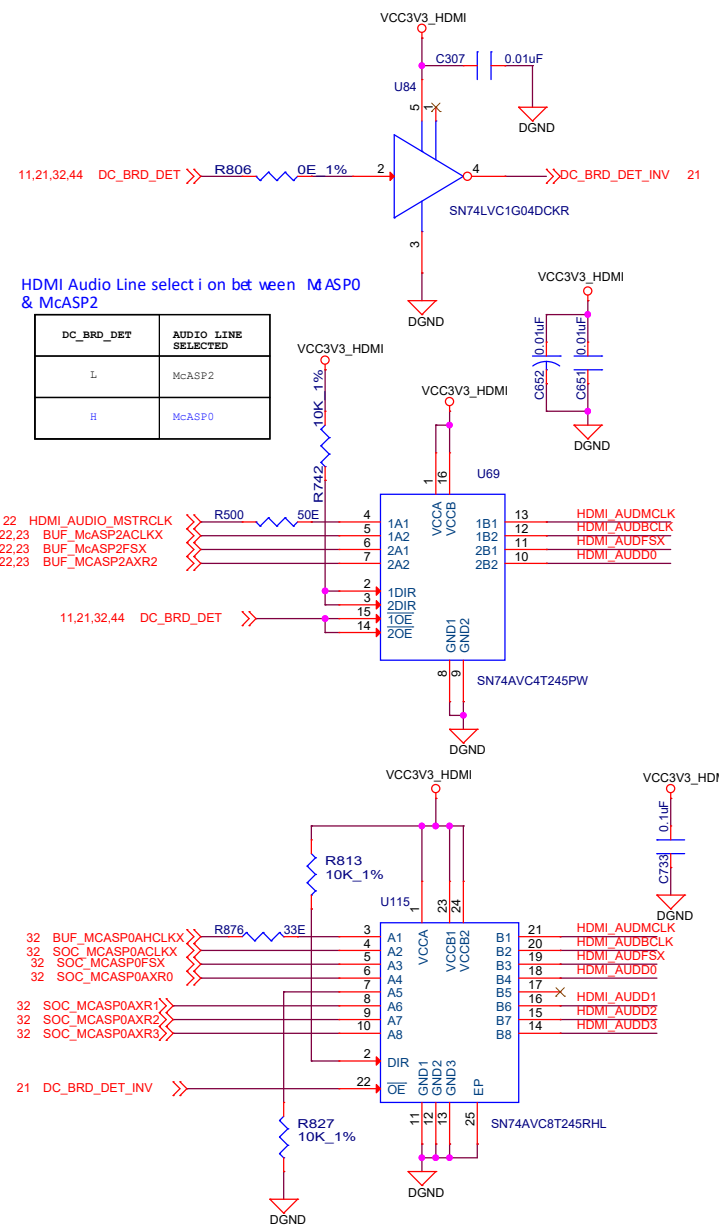

HDMI TRANSMITTER

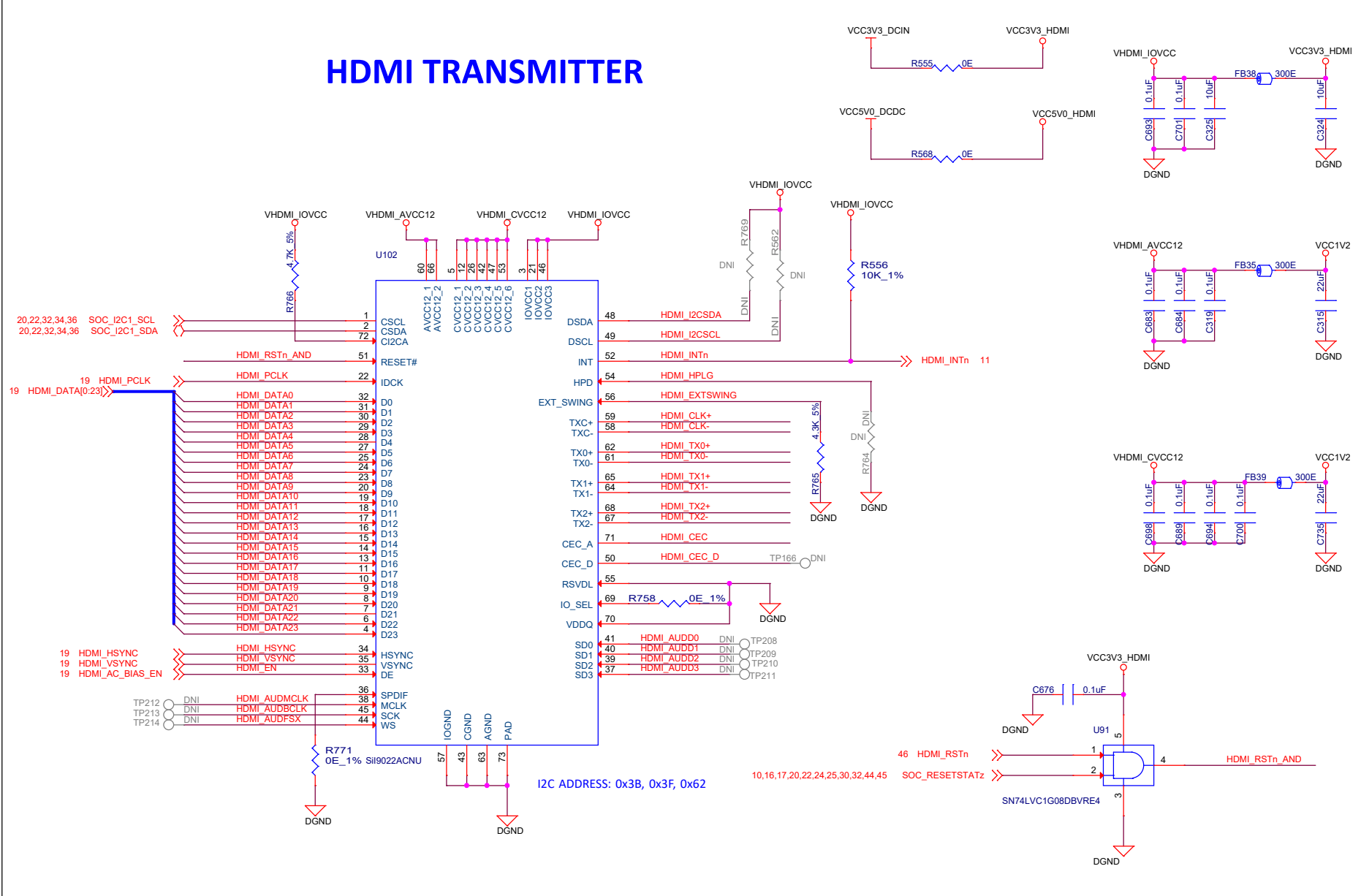

HDMI 1.2V GENERATION

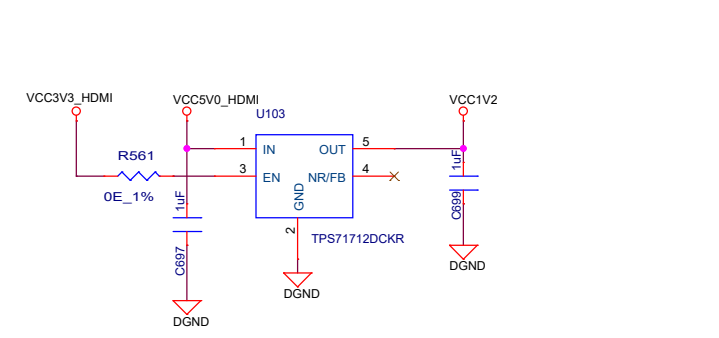

HDMI ESD DEVICE

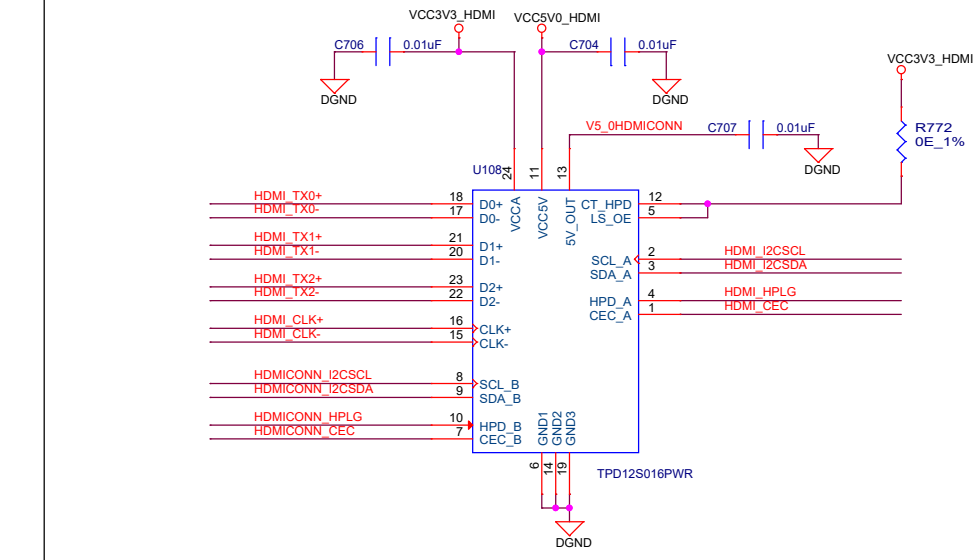

NOTE:
 TPD12S016PWR has integrated pullup or pulldown resistors on the I2C and HPD lines hence no external pullup or pulldown required.

HDMI CONNECTOR

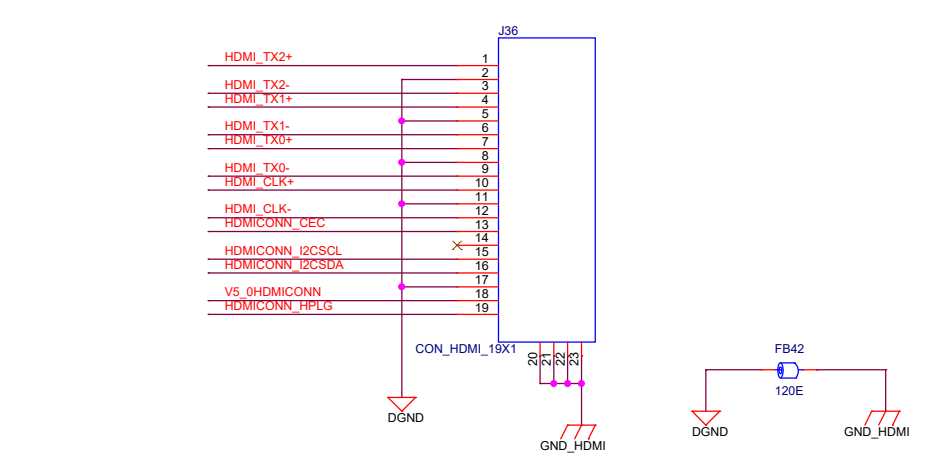

Designed for TI by Mistral Solutions Pvt Ltd



Title		HDMI TRASMITTER	
Size	Variant Name = Proj PROC046 002 OPN# EVMK2GX5	Rev	A
Date:	Friday, February 02, 2018	Sheet	21 of 51

AUDIO CODEC RESET

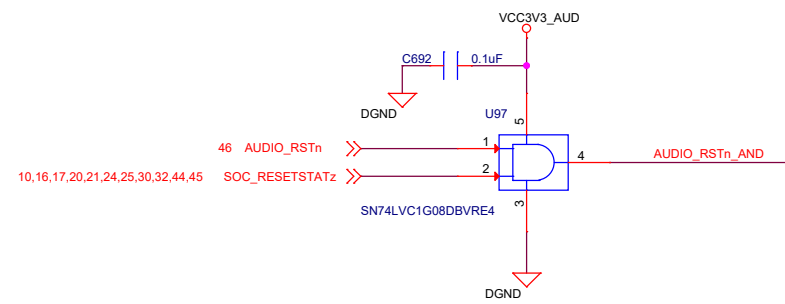

CODEC I2C ADDRESS SELECTION

MFP0	MFP1	ADDRESS
L	L	1A
L	H	1B
H	L	1C
H	H	1D

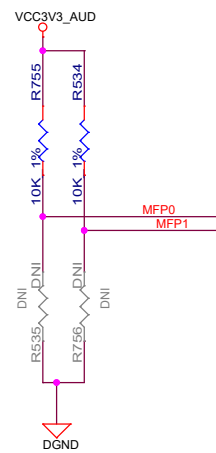

AUDIO CODEC

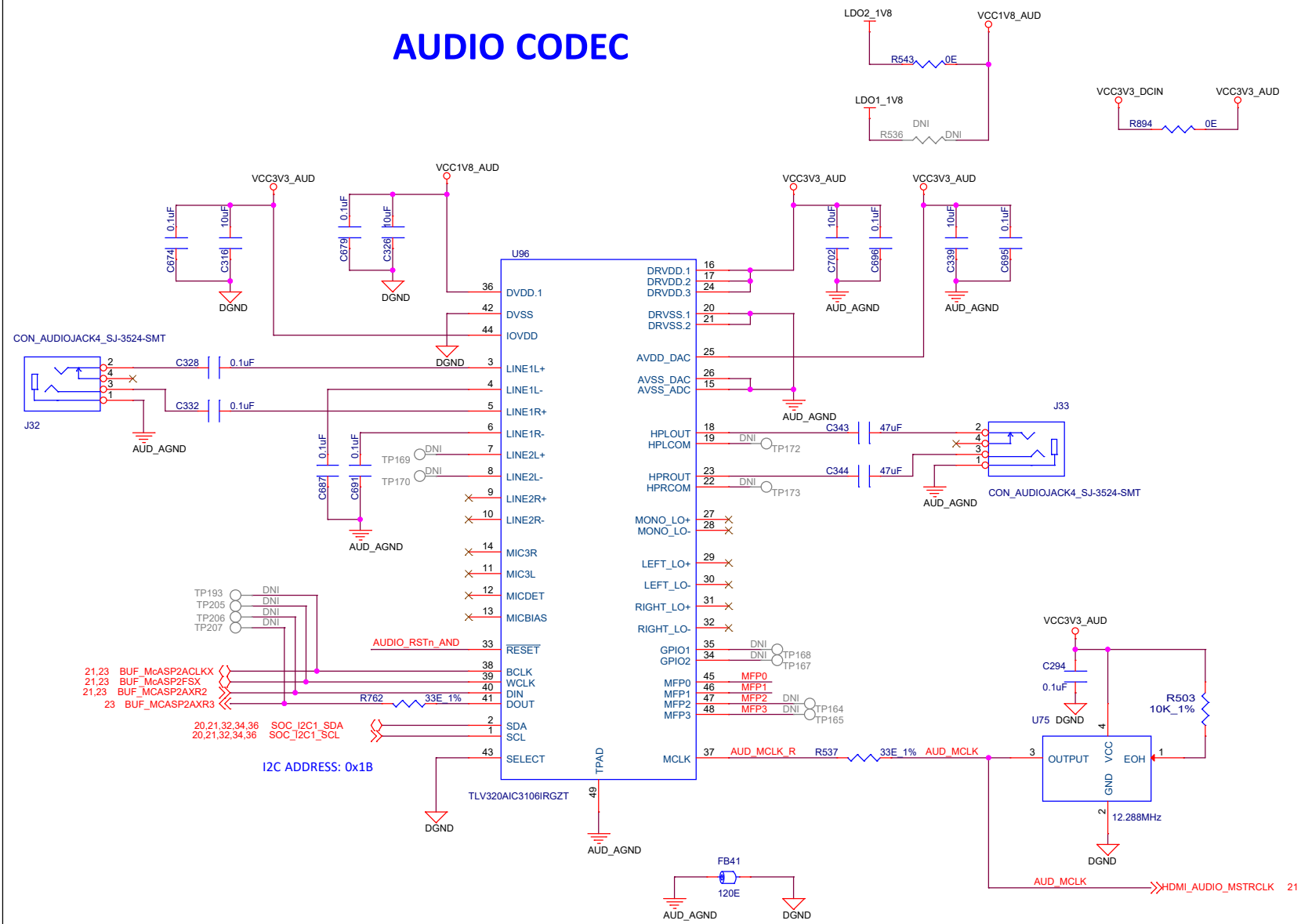

AUDIO BUFFER

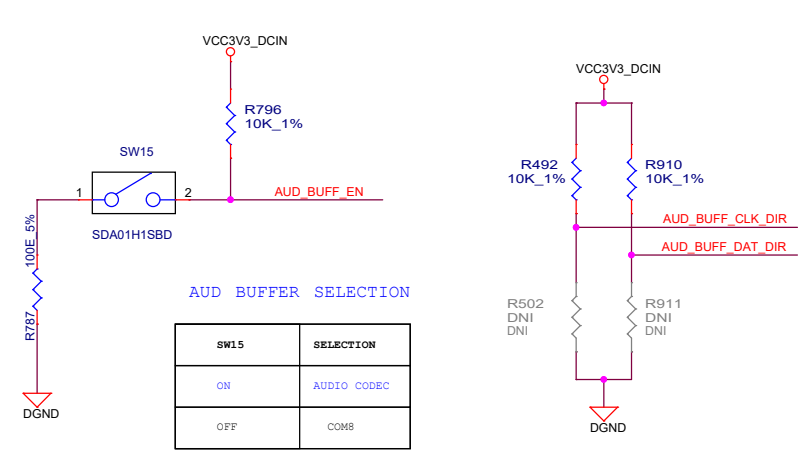

AUD BUFFER SELECTION

SW15	SELECTION
ON	AUDIO CODEC
OFF	COM8

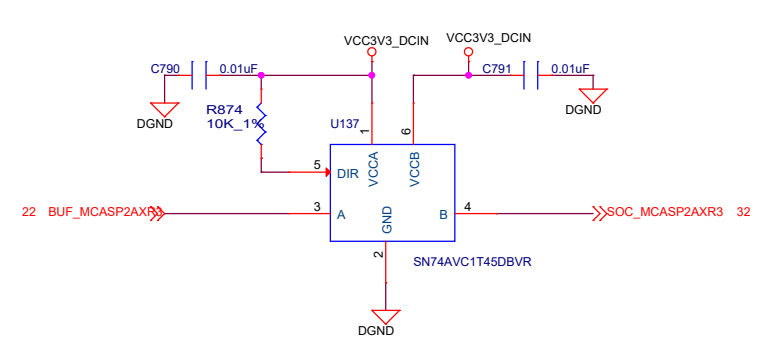
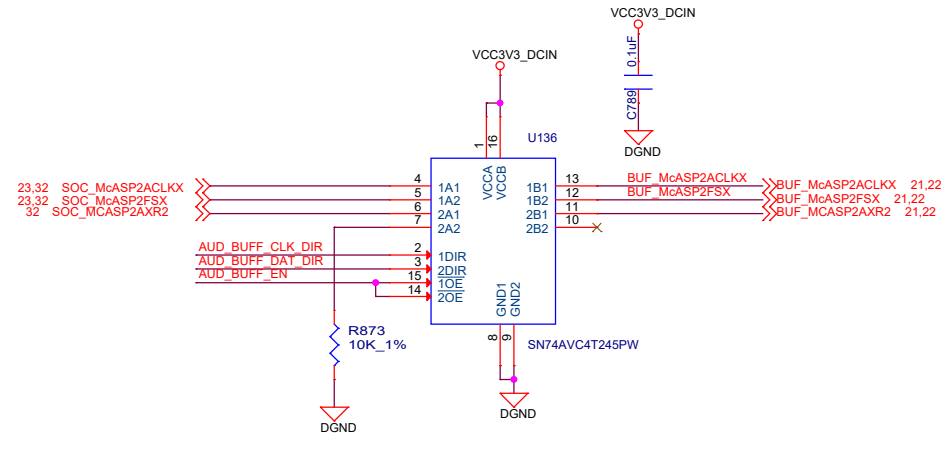
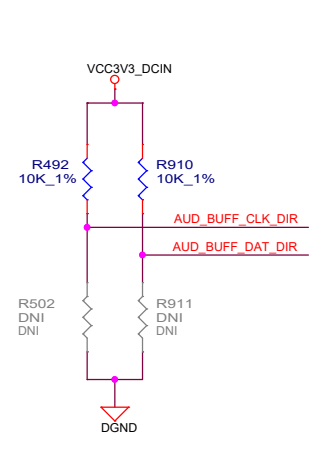

COM8 BUFFER

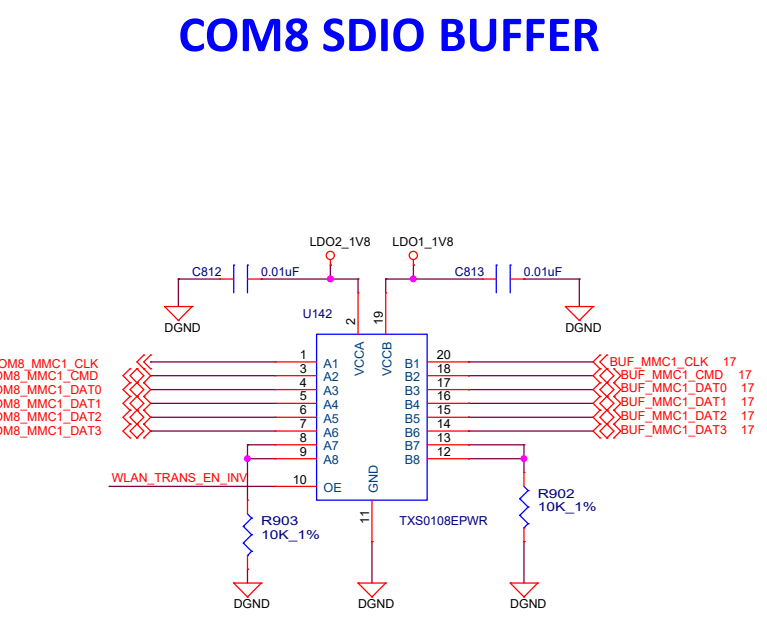
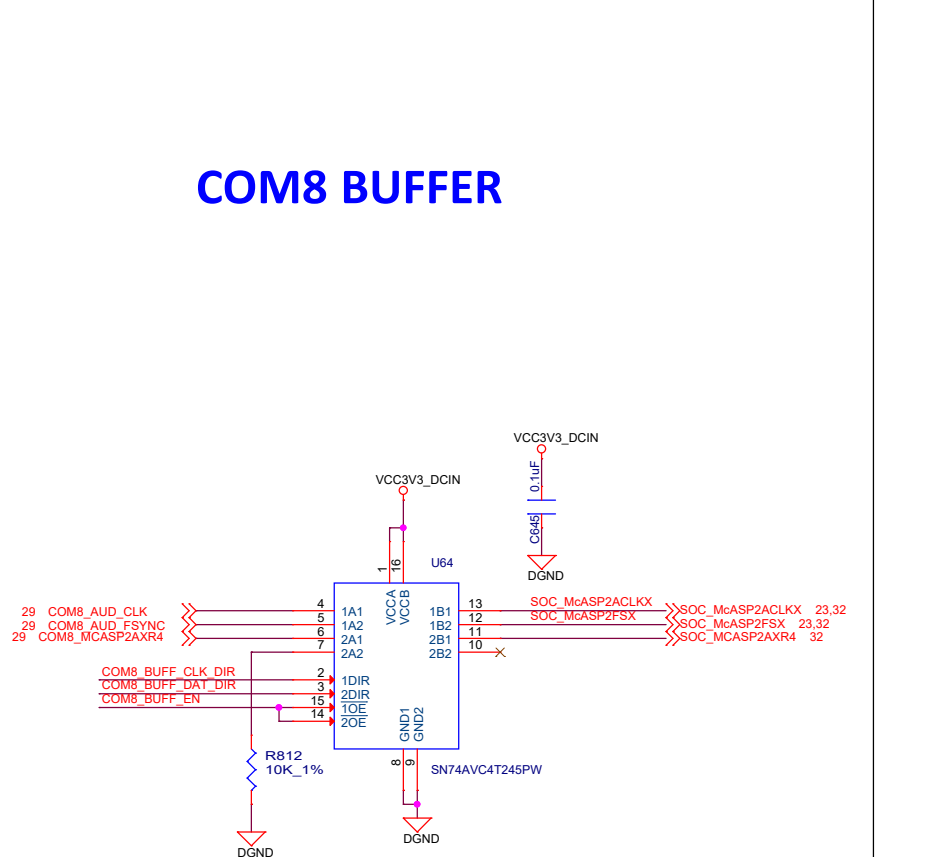
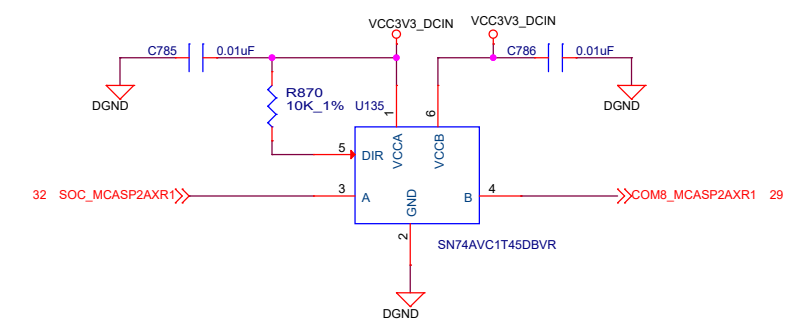

COM8 SDIO BUFFER

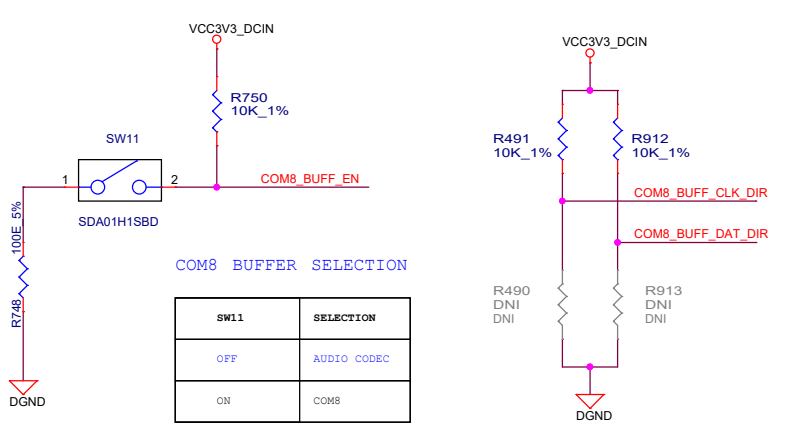

COM8 BUFFER SELECTION

SW11	SELECTION
OFF	AUDIO CODEC
ON	COM8

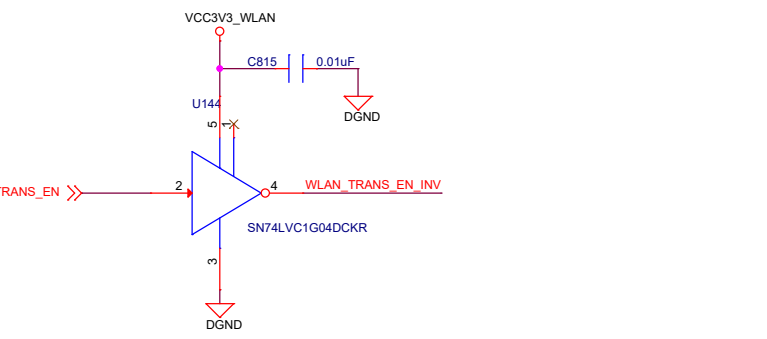
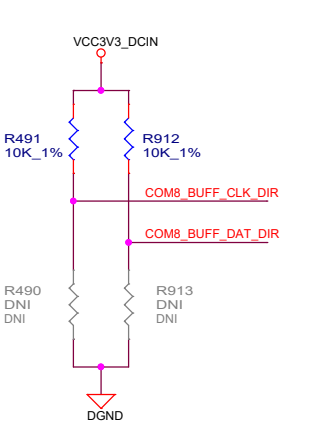

Designed for T1 by Mistral Solutions Pvt Ltd



Title: MCASP2 BUFFERS FOR COM8 , HDMI & AUDIO CODEC

Size	Variant Name = Proj PROC046 002 OPN# EVMK2GXS	Rev
C		A
Date:	Friday, February 02, 2018	Sheet 23 of 51

ETHERNET PHY

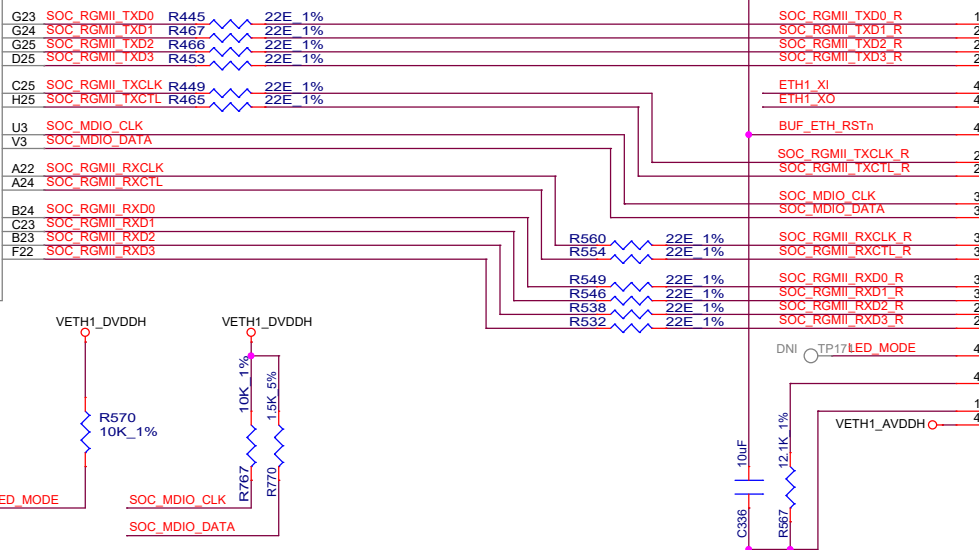
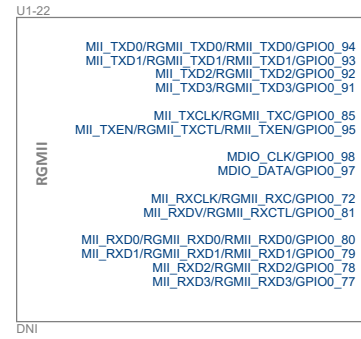

ETHERNET CONNECTOR

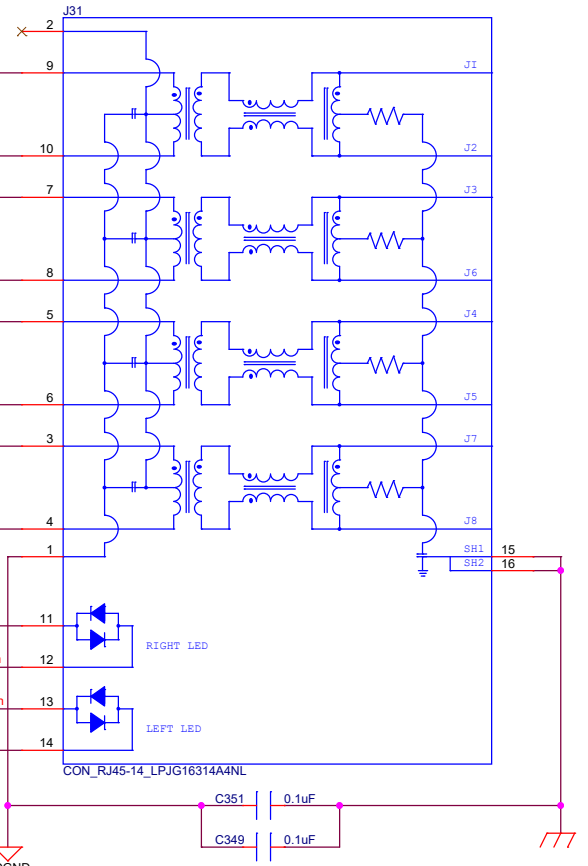

ETHERNET MODE CONFIGURATION

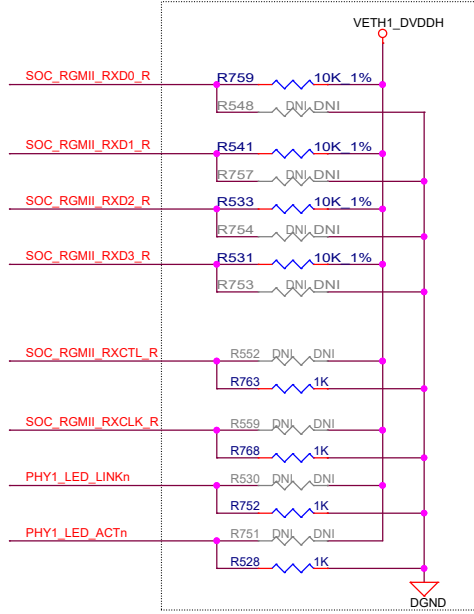

RXD[3:0]	MODE
0100	NAND TREE
0111	CHIP POWER DOWN
1100	RGMII MODE - ADVERTISE 1000 BASE-T FULL DUPLEX ONLY
1101	RGMII MODE- ADVERTISE 1000 BASE-T FULL & HALF DUPLEX ONLY
1110	RGMII MODE- ADVERTISE ALL CAPABILITIES (10/100/1000 SPEED HALF / FULL DUPLEX), EXCEPT 1000 BASE-T HALF DUPLEX
1111	RGMII MODE- ADVERTISE ALL CAPABILITIES (10/100/1000 SPEED HALF / FULL DUPLEX)

ETHERNET ESD DEVICES

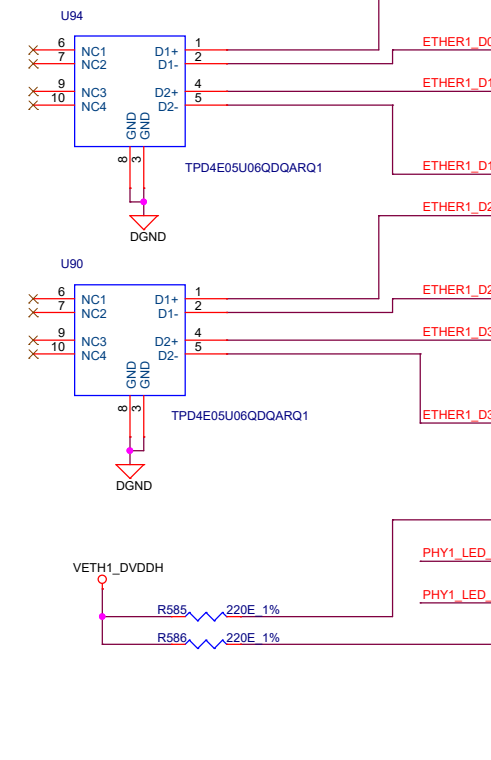

ETHERNET RESET

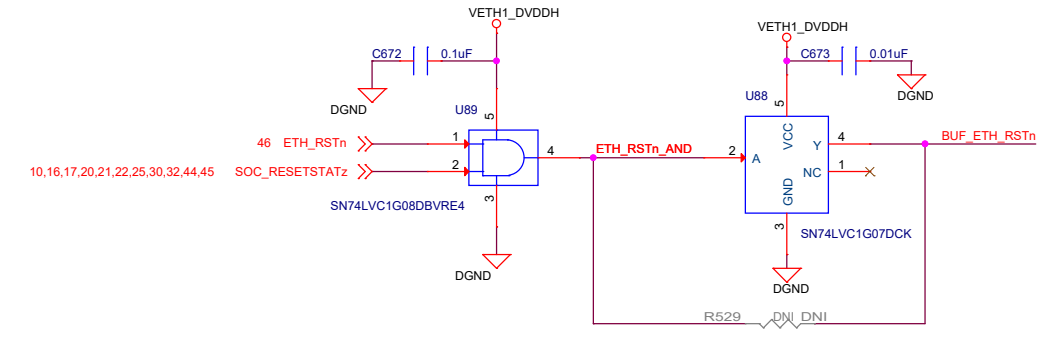

Designed for T1 by Mistral Solutions Pvt Ltd



Title		ETHERNET PHY	
Size	Variant Name = Proj PROC046 002 OPN# EVMK2GX5	Rev	A
Date:	Friday, February 02, 2018	Sheet	24 of 51

PCI EXPRESS x1 CONNECTOR

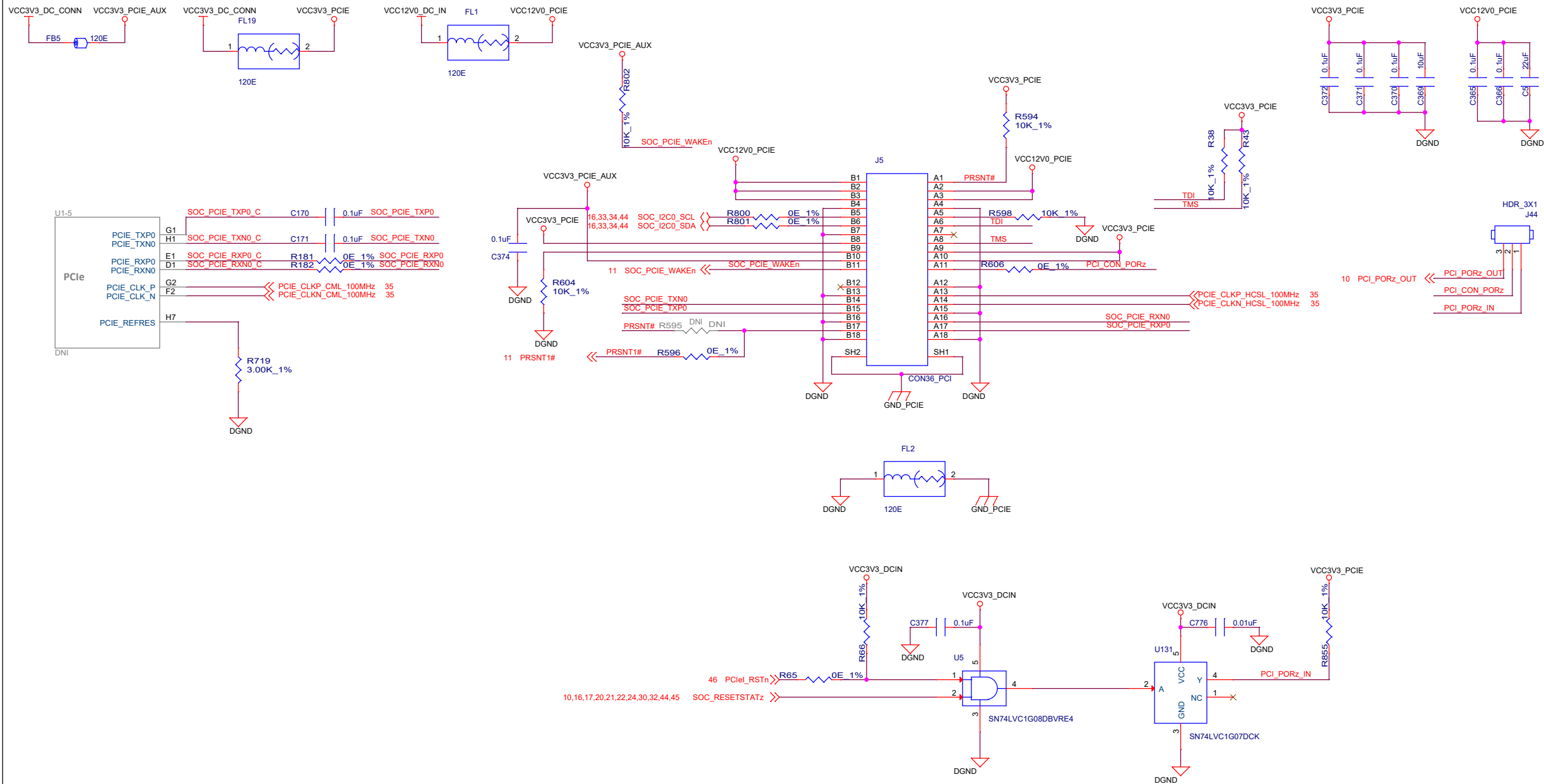

Designed for T1 by Mistral Solutions Pvt Ltd



Title: PCIe x1 CONNECTOR

Size	Variant Name = Proj PROC046 002 OPN# EVMK2GXS	Rev
C		A
Date:	Friday, February 02, 2018	Sheet 25 of 51

USB1 DUAL ROLE

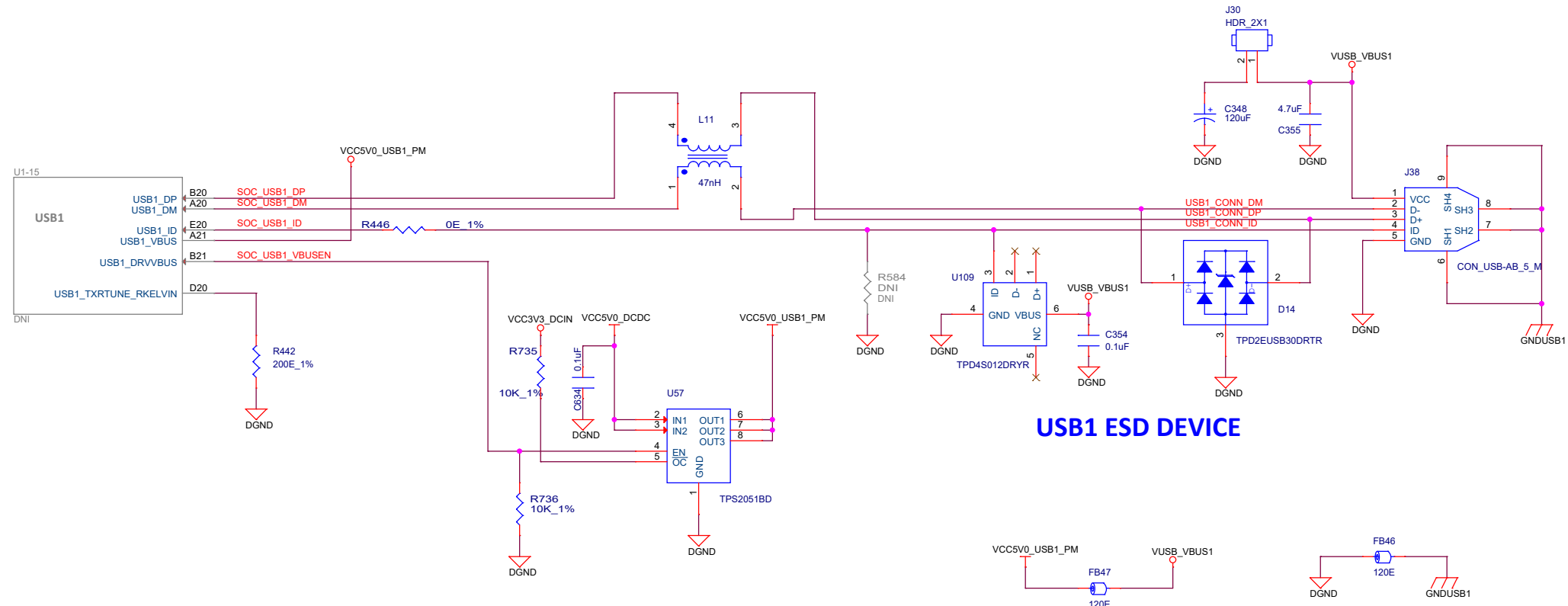

USB1 ESD DEVICE

USB0 HOST

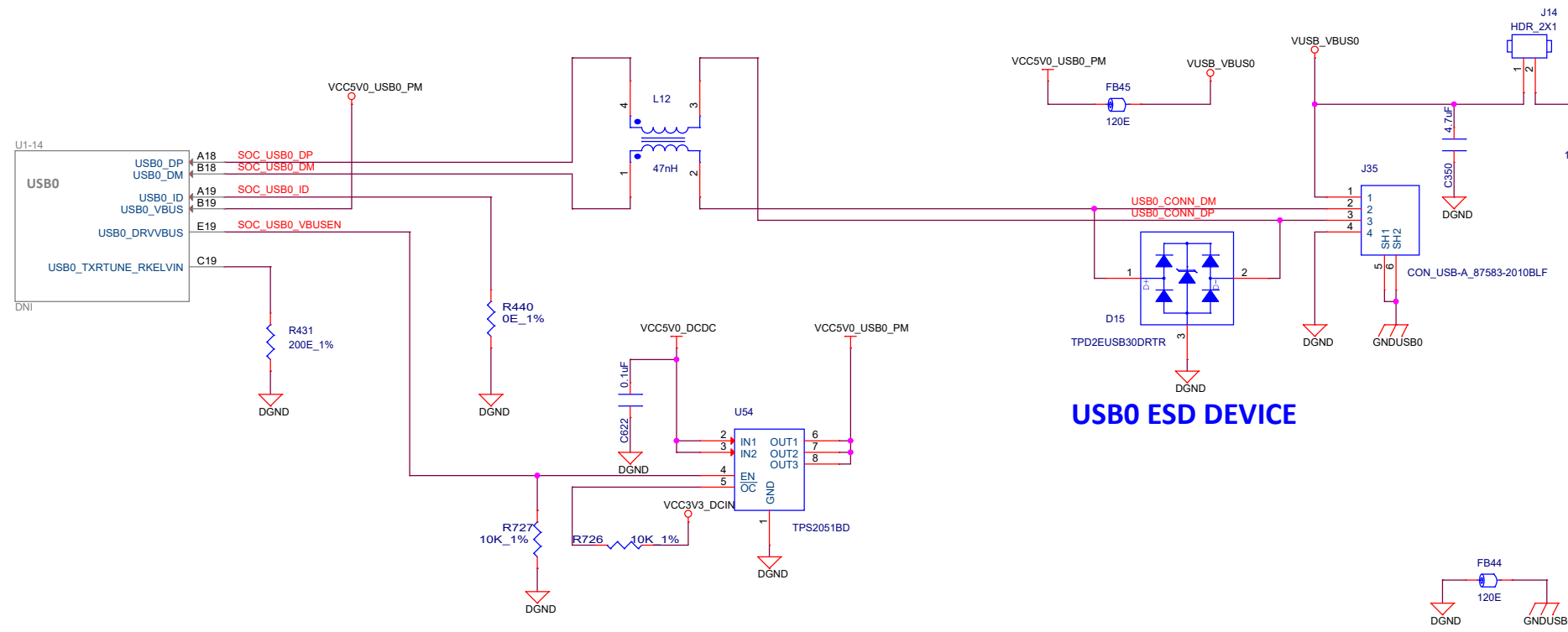

USB0 ESD DEVICE

Designed for T1 by Mistral Solutions Pvt Ltd



Title		USB DUAL ROLE & HOST	
Size	Variant Name = Proj PROC046 002 OPN# EVMK2GXS	Rev	A
Date:	Friday, February 02, 2018	Sheet	26 of 51

SoC UART0

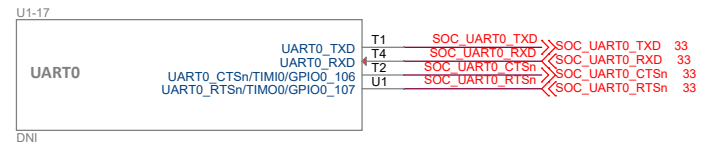

SoC UART1

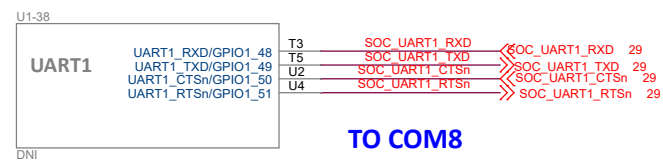

SoC_UART0 MUX: CP2105 or DB9

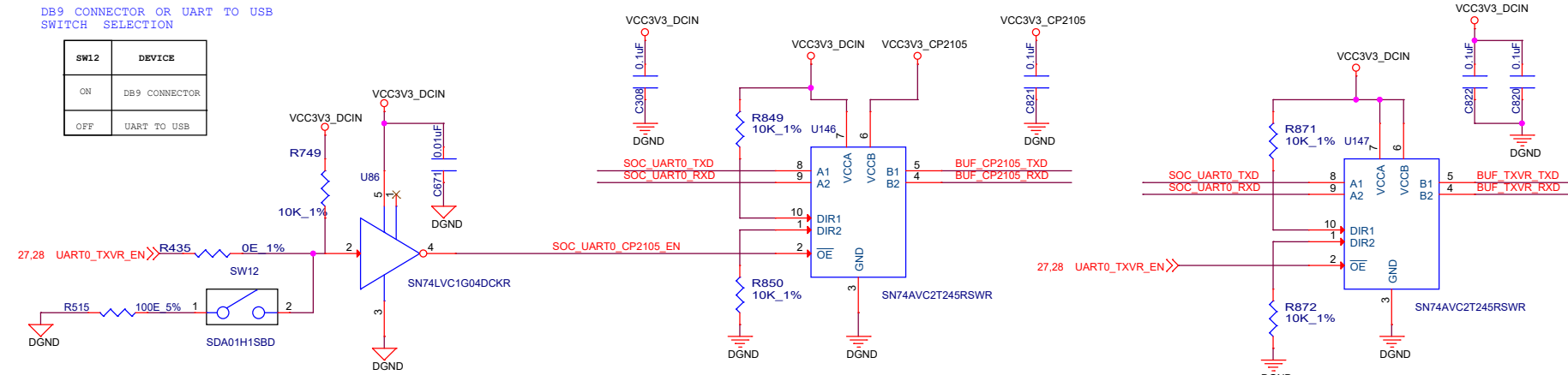

MUX BETWEEN BMC UART0 TO USB & 4 PIN HDR

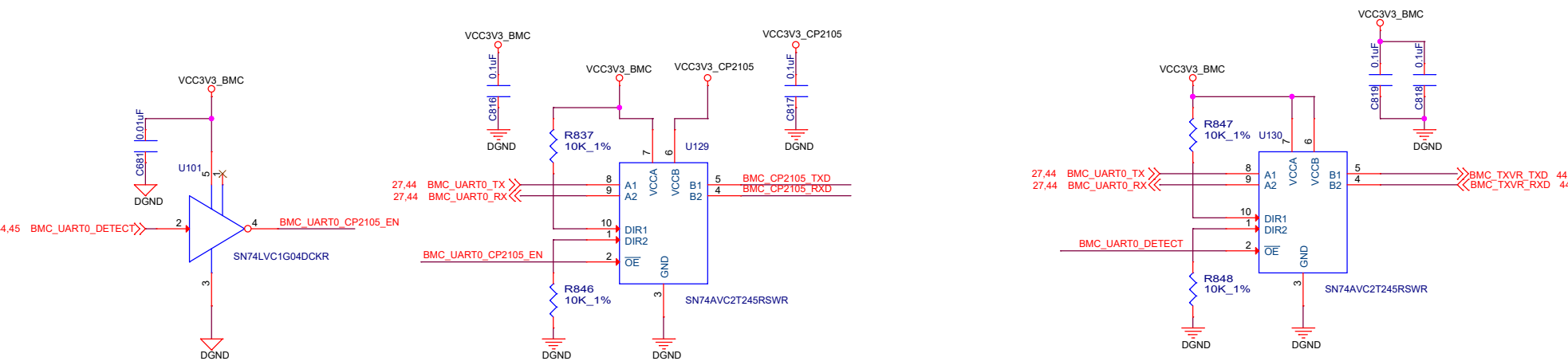

SoC_UART0 MUX SELECTION

SOC_UART0_CP2105_EN	SoC_UART0 Connected to
L	CP2105 (USB-to-UART)
H	UART TRANSCIEVER DB9 CONNECTOR

SoC UART0 & BMC CONSOLE OVER USB

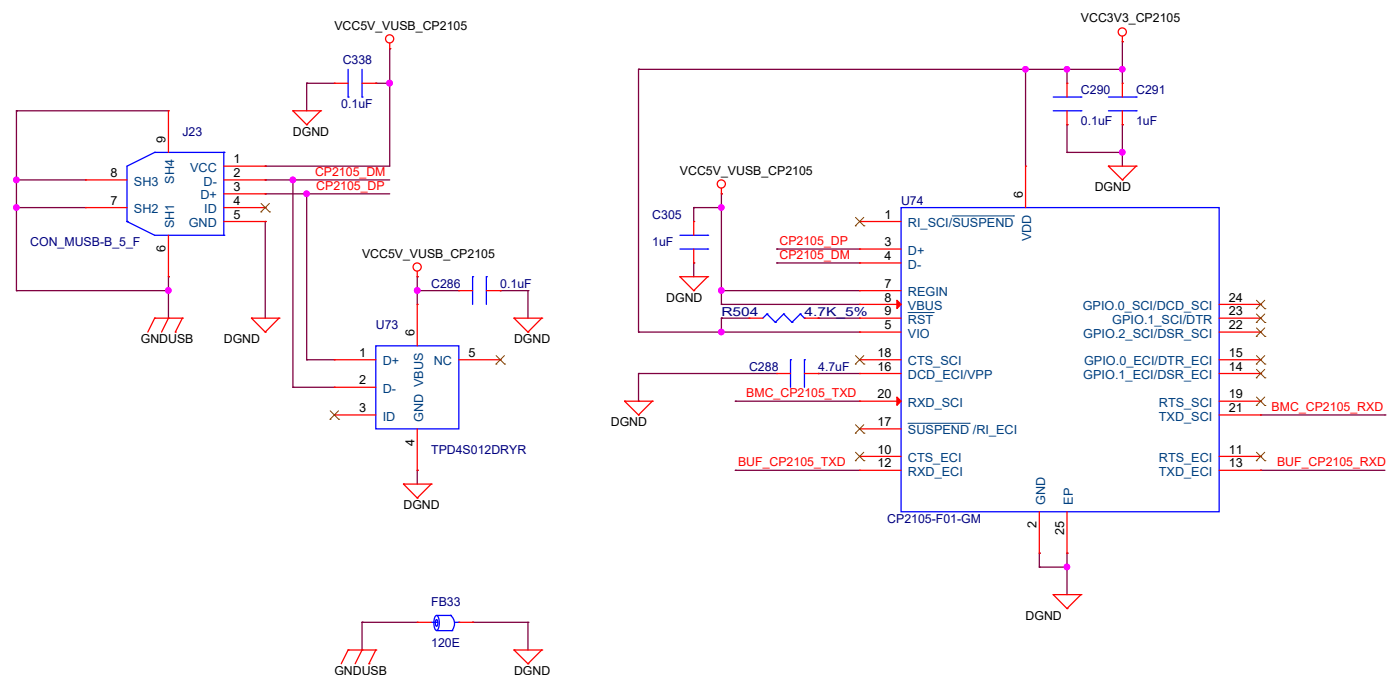

UART0 DB9 CON

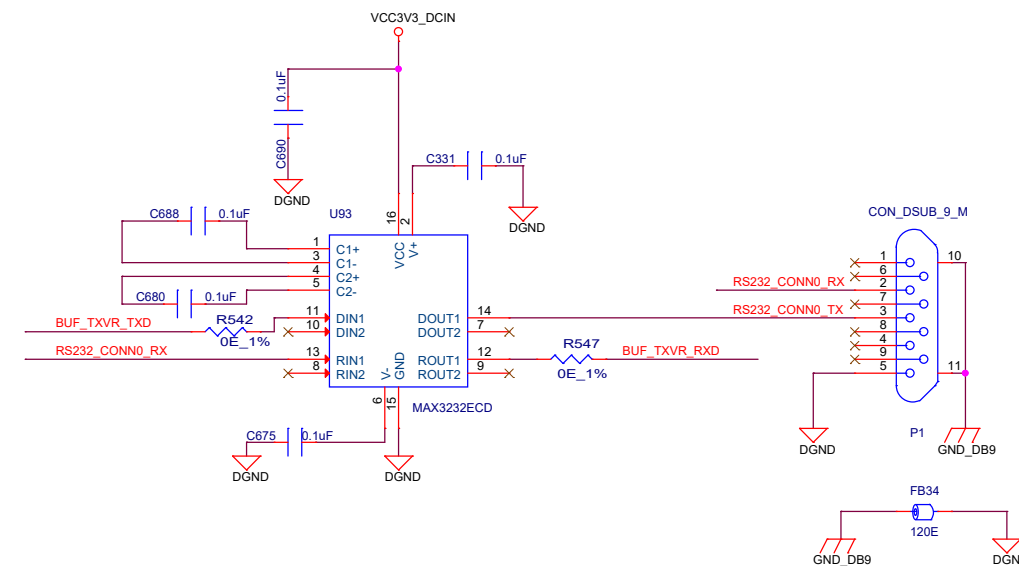

Designed for T1 by Mistral Solutions Pvt Ltd



Title UART 0,1,& 2

Size	Variant Name = Proj PROC046 002 OPN# EVMK2GXS	Rev
C		A
Date:	Friday, February 02, 2018	Sheet 27 of 51

SoC UART2

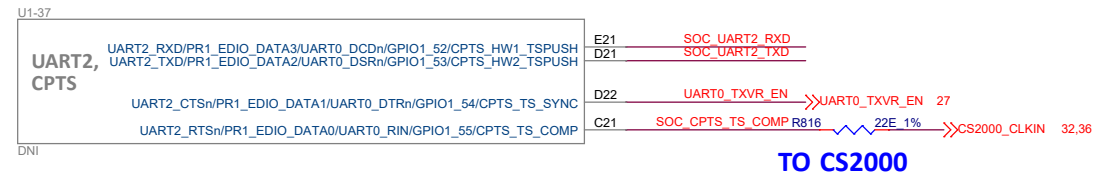

SoC UART2 MUX - BMC or UART2 Header

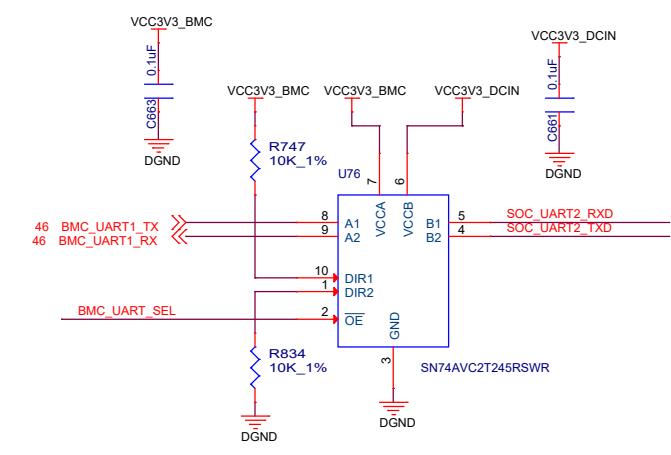

UART2 HEADER

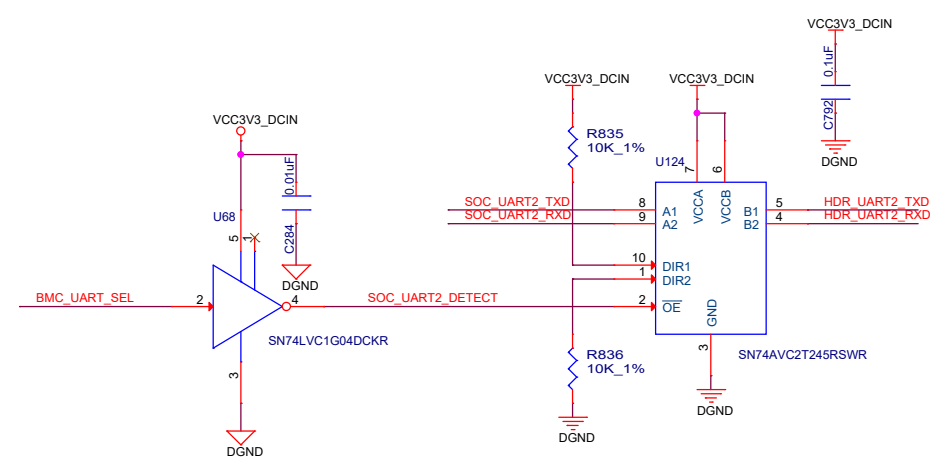
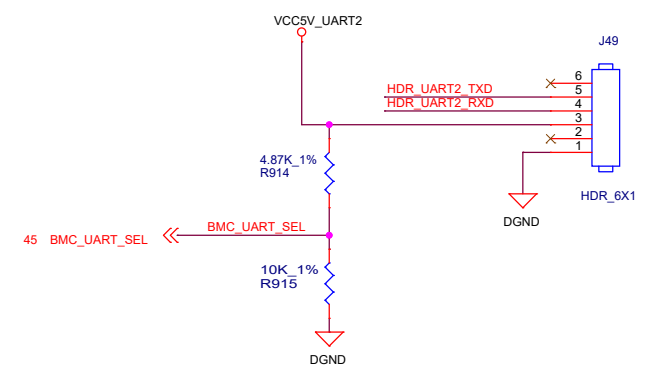

SoC_UART2 MUX SELECTION

BMC_UART_SEL	SoC_UART2 Connected to
L	BMC
H	UART2 HEADER (J49)

Designed for T1 by Mistral Solutions Pvt Ltd



Title		UART2	
Size	Variant Name = Proj PROC046 002 OPN# EVMK2GXS	Rev	A
Date:	Friday, February 02, 2018	Sheet	28 of 51

COM8 CONNECTOR

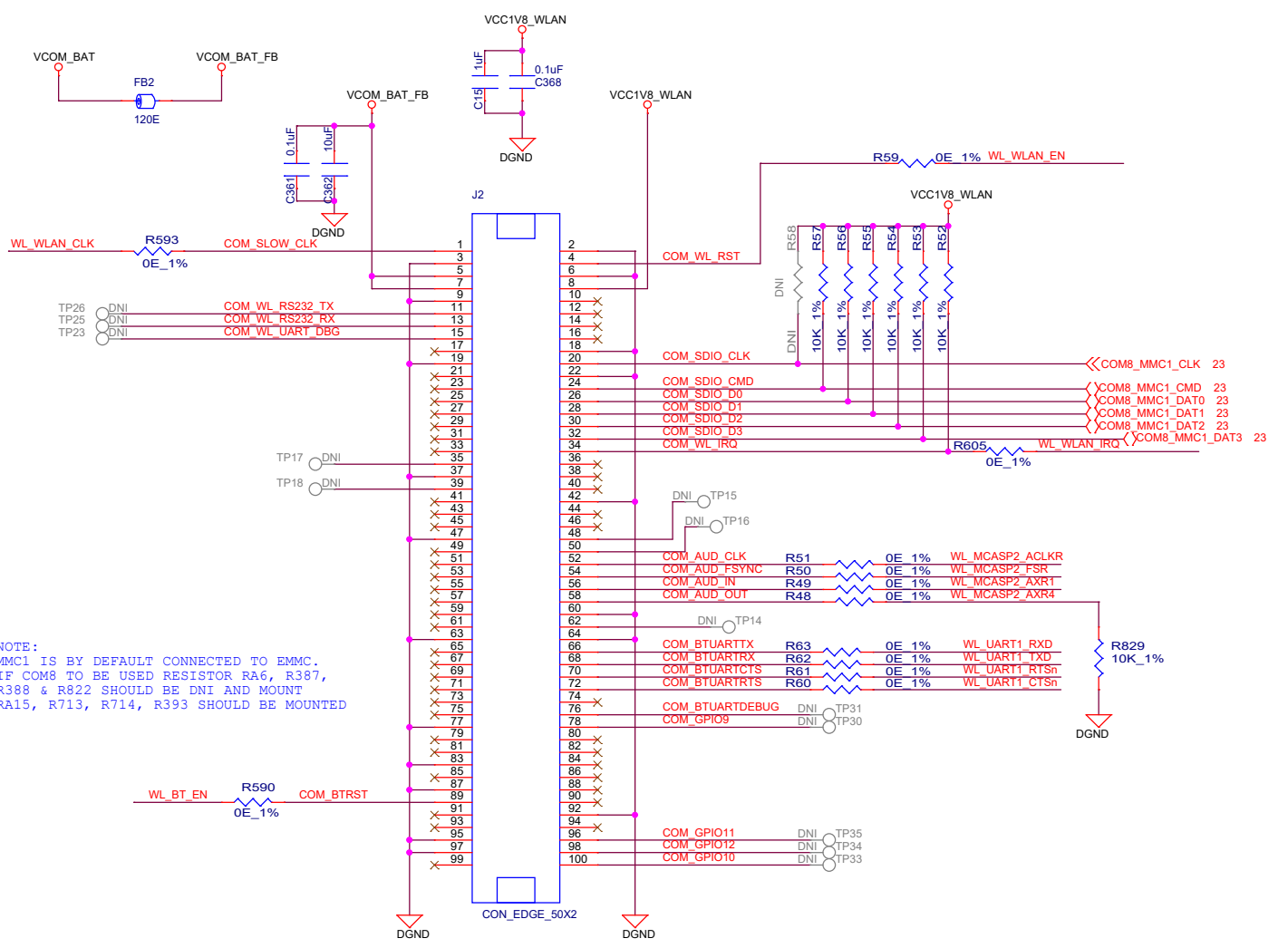

NOTE:
MMC1 IS BY DEFAULT CONNECTED TO EMMC.
IF COM8 TO BE USED RESISTOR RA6, R387,
R388 & R822 SHOULD BE DNI AND MOUNT
RA15, R713, R714, R393 SHOULD BE MOUNTED

CONNECTION ON COM8 IS FOLLOWED AS PER
AM437x GP EVM. THESE ARE GPIOs ARE NOT USED
IN AM437x GP EVM, SO WE PROVIDED AS TEST POINTS

COM8 LEVEL TRANSLATOR1

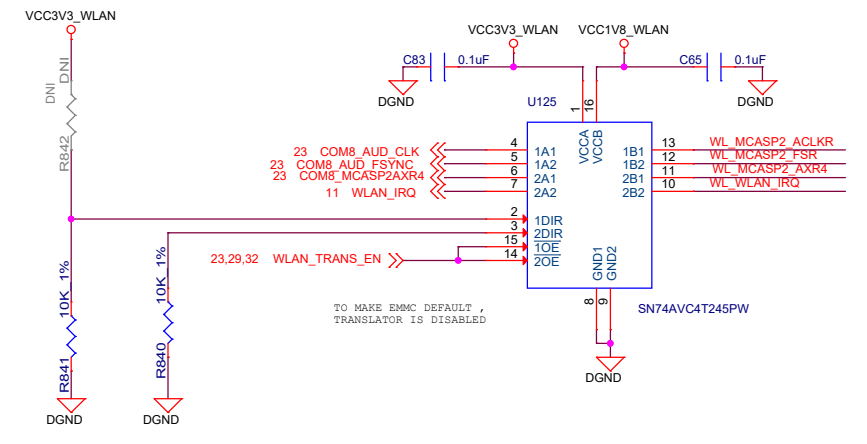

COM8 LEVEL TRANSLATOR2

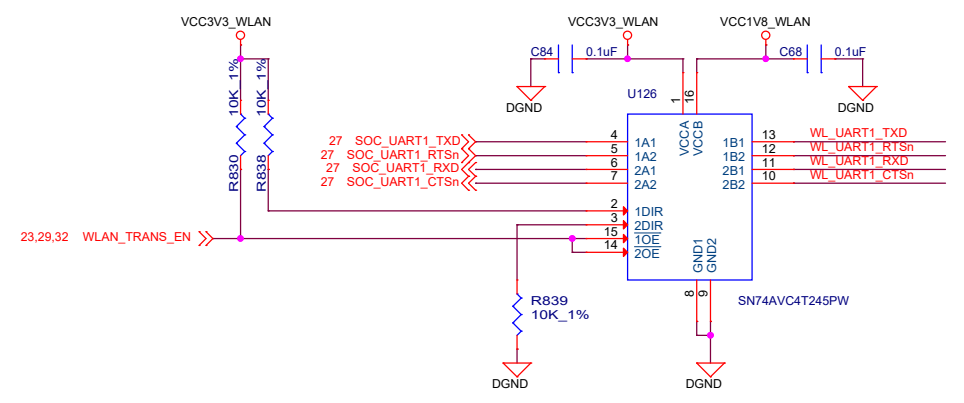

COM8 VBAT GENERATION

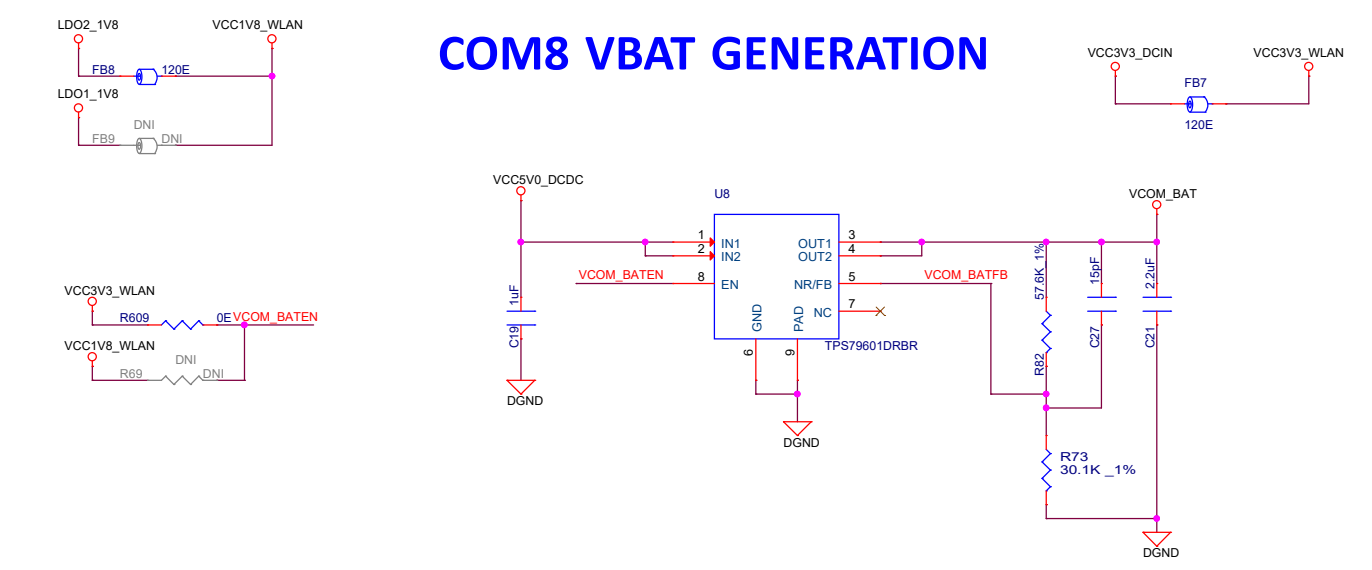

COM8 LEVEL TRANSLATOR3

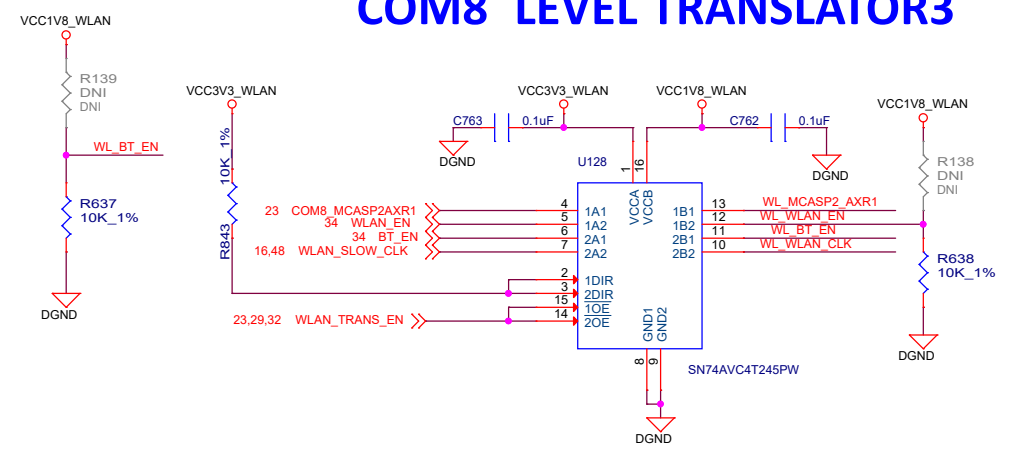

Designed for T1 by Mistral Solutions Pvt Ltd



Title		COM8 CONNECTOR
Size	Variant Name = Proj PROC046 002 OPN# EVMK2GXS	Rev
C		A
Date:	Friday, February 02, 2018	Sheet 29 of 51

MLB CONNECTOR

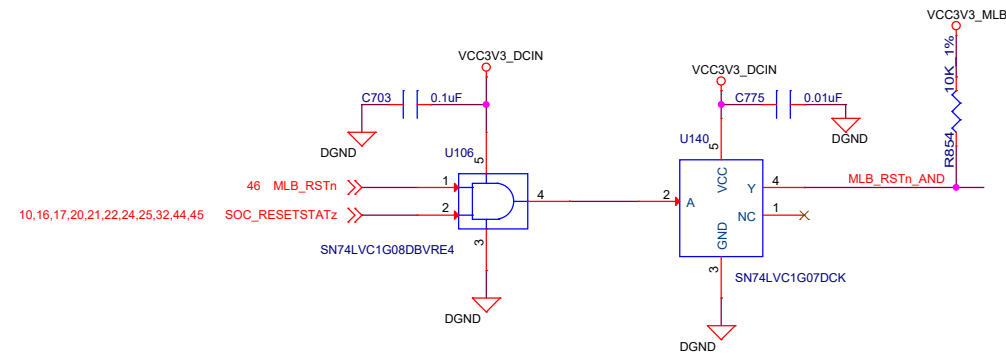
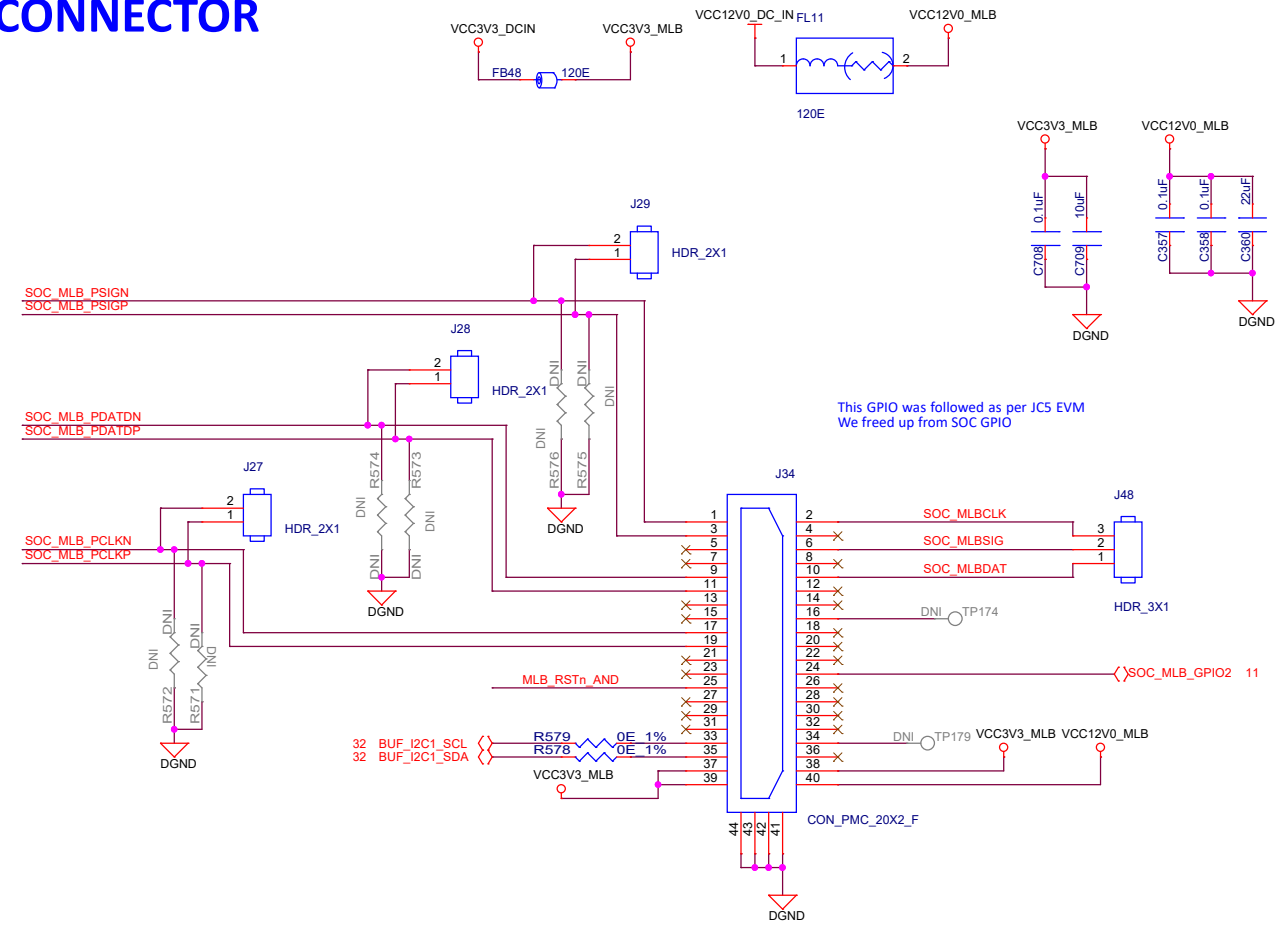
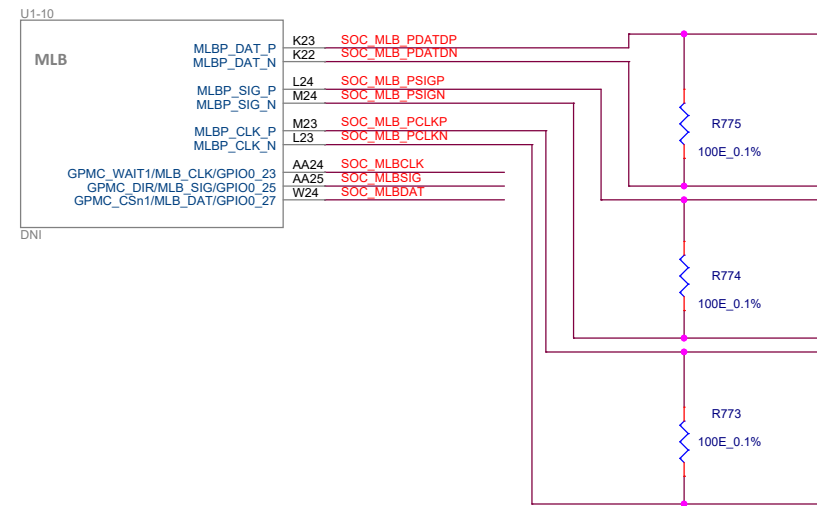

Designed for T1 by Mistral Solutions Pvt Ltd



Title MLB CONNECTOR

Size	Variant Name = Proj PROC046 002 OPN# EVMK2GXS	Rev
C		A
Date:	Friday, February 02, 2018	Sheet 30 of 51

DCAN0

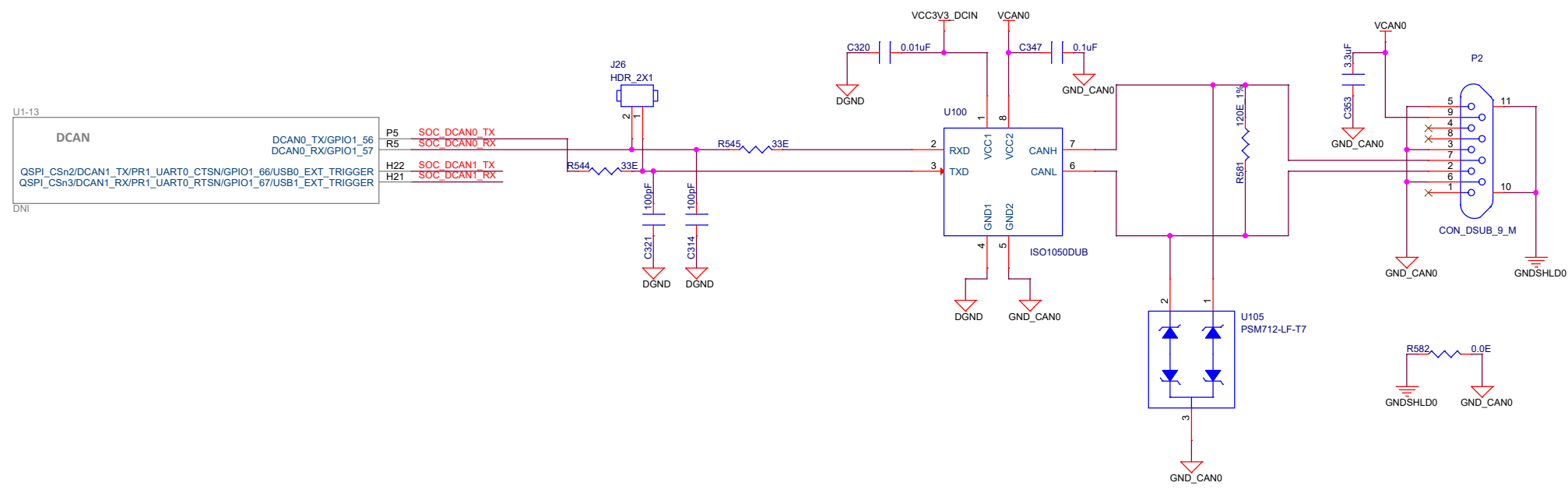

DCAN0 POWER

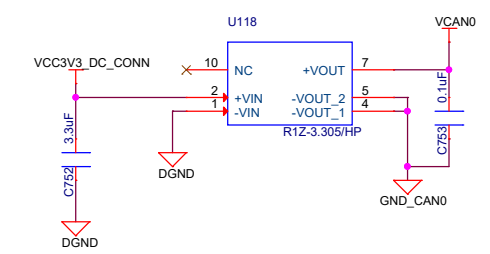

DCAN1

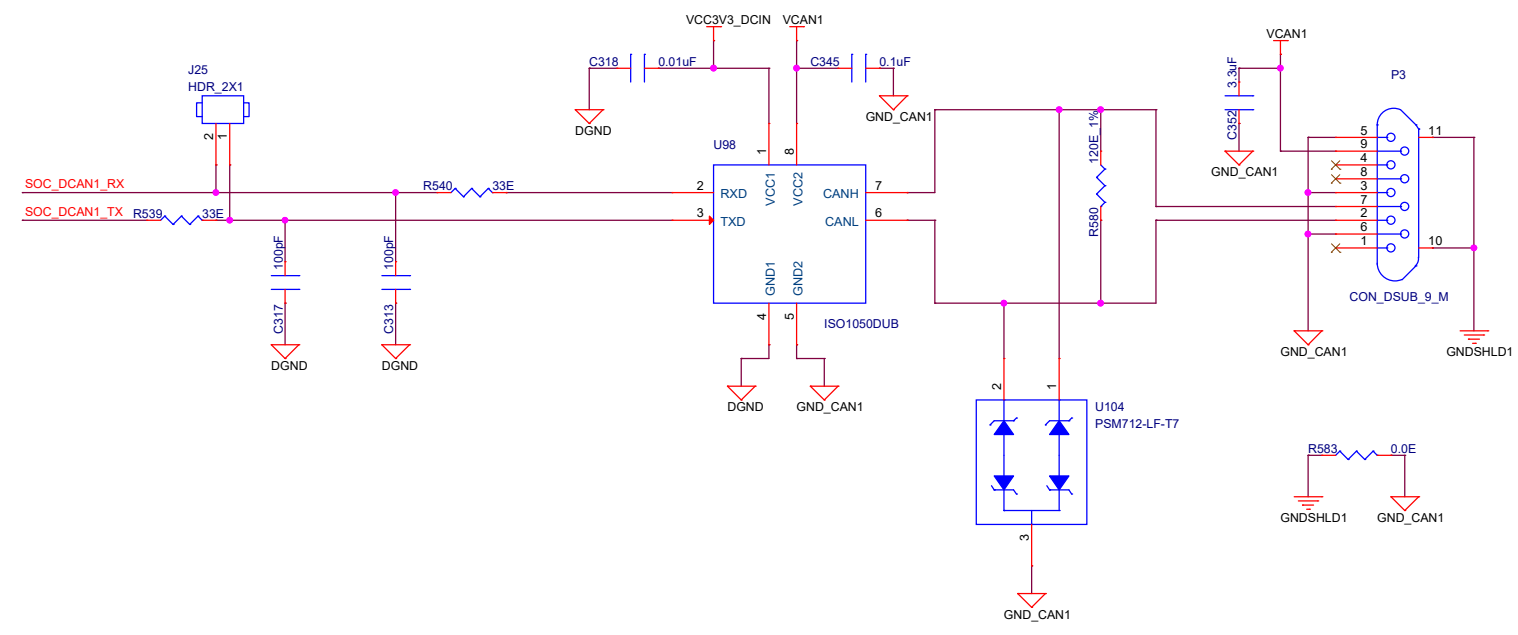

DCAN1 POWER

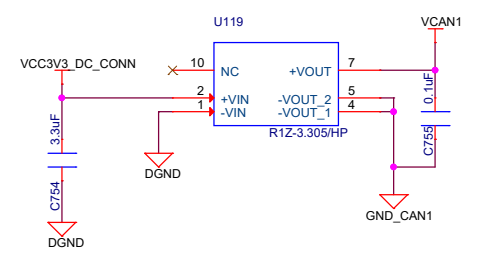

Designed for T1 by Mistral Solutions Pvt Ltd



Title		DCAN CONNECTOR	
Size	Variant Name = Proj PROC046 002 OPN# EVMK2GXS	Rev	
C		A	
Date:	Friday, February 02, 2018	Sheet	31 of 51

SOC MCASP

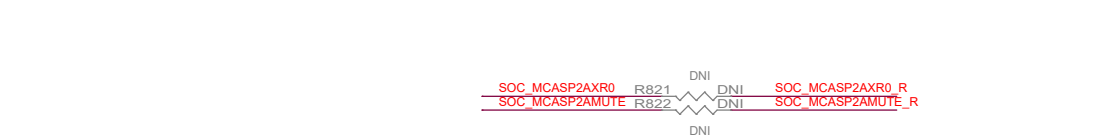
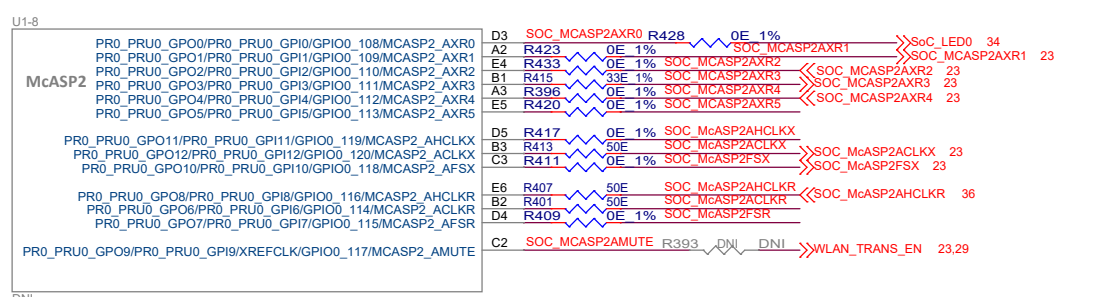
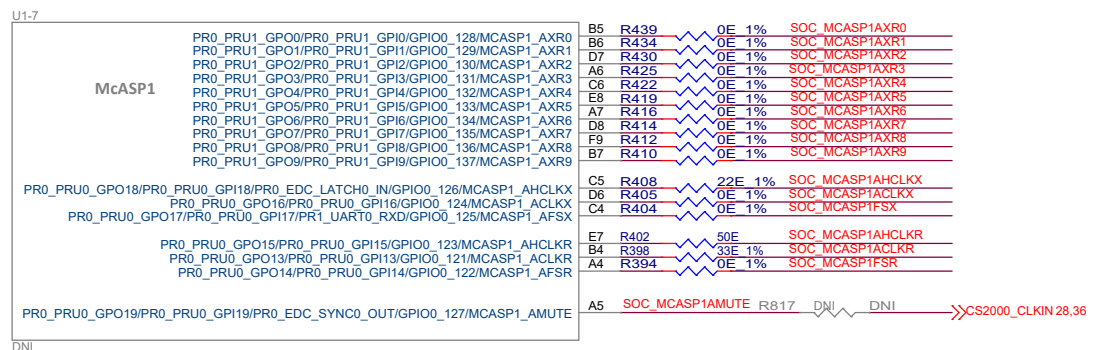
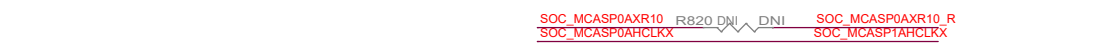
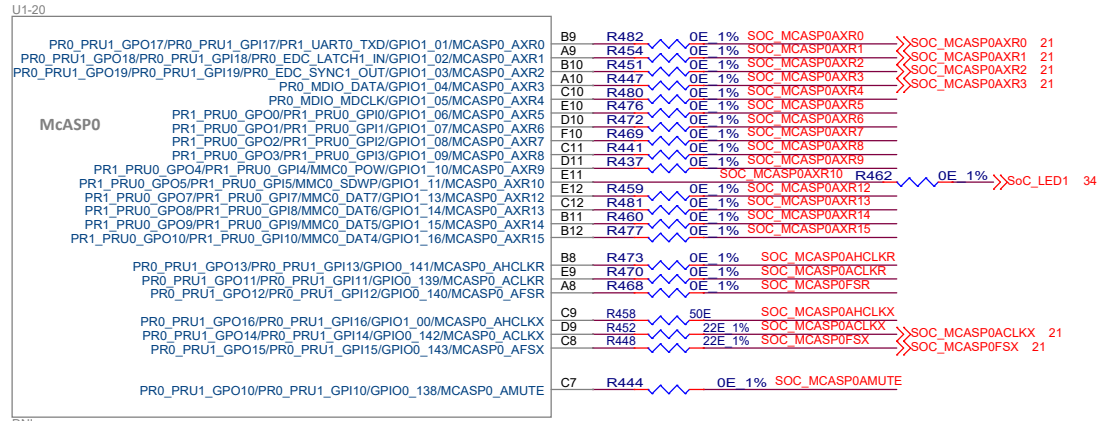

AUDIO EXP CONNECTOR

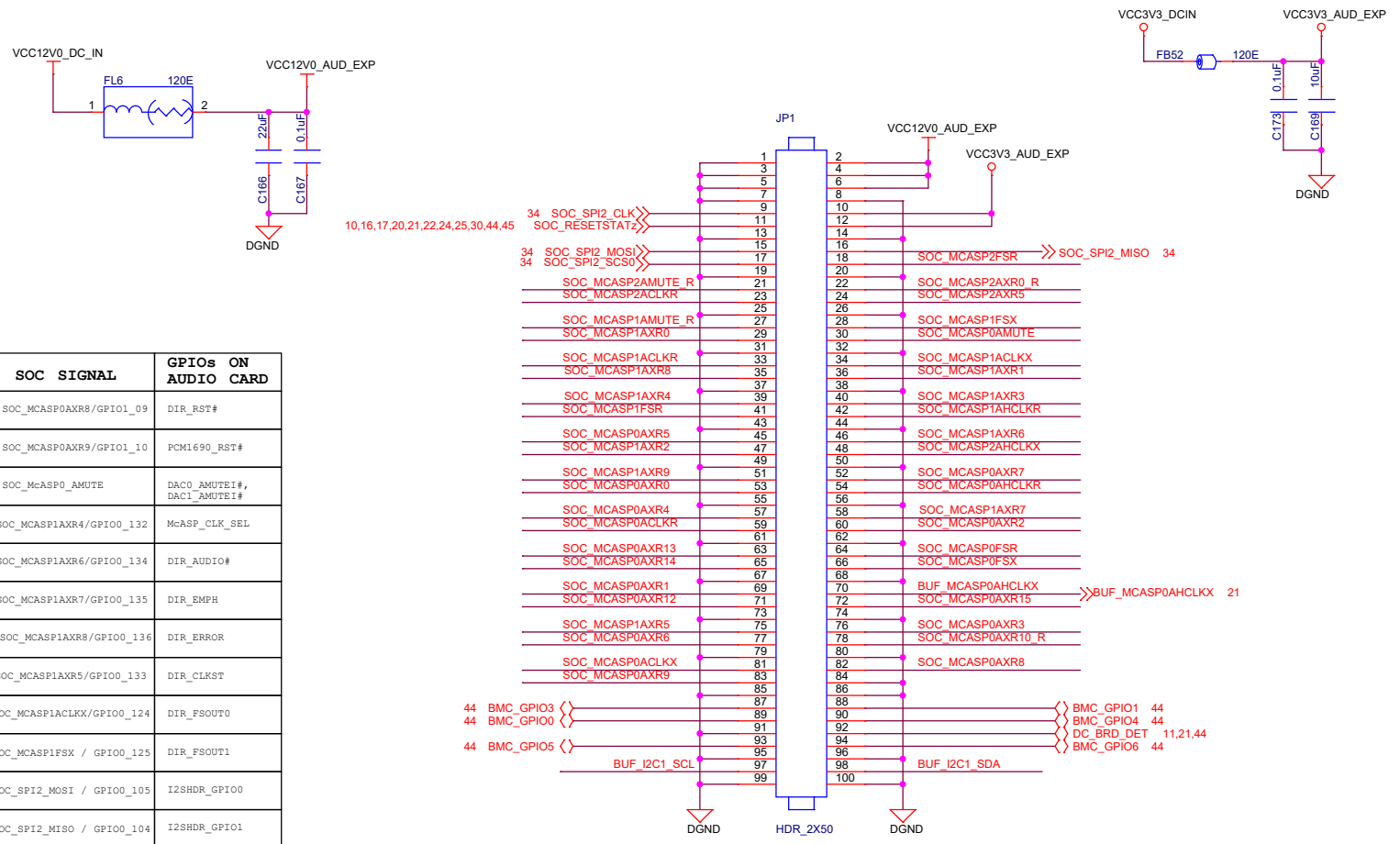

McASP0AHCLKX_BUFFER

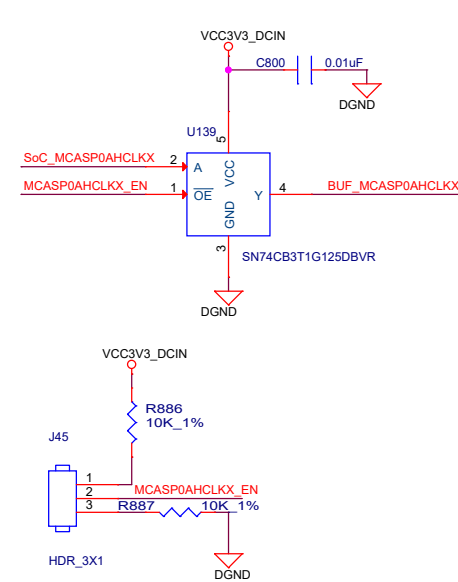

I2C BUFFER

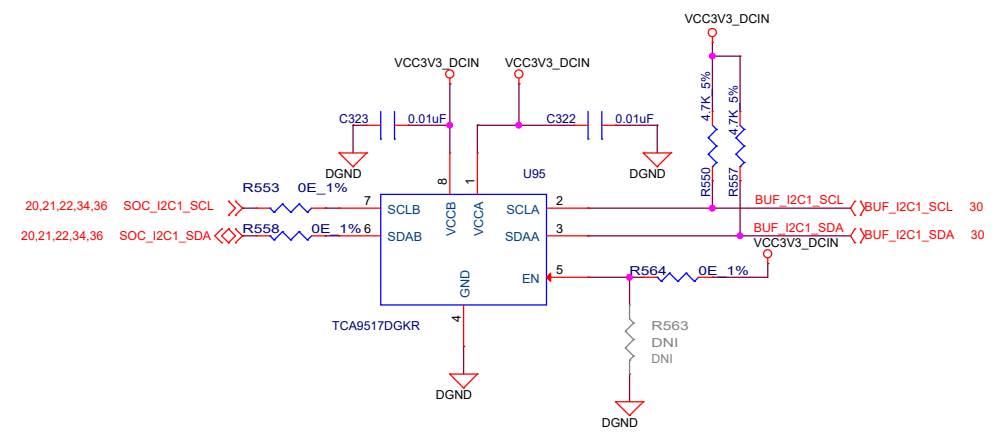

Designed for T1 by Mistral Solutions Pvt Ltd



Title		AUDIO EXP CONNECTOR	
Size	Variant Name = Proj PROC046 002 OPN# EVMK2GX5	Rev	
C		A	
Date:	Friday, February 02, 2018	Sheet	32 of 51

SoC McBSP

U1-31		
MCBSP, PR1_PRU1_GPO9/PR1_PRU1_GPI9/MCBSP_DR/GPIO1_35	D15	SOC_MCBSPDR
TIMER, PR1_PRU1_GPO10/PR1_PRU1_GPI10/MCBSP_DX/GPIO1_36	A16	SOC_MCBSPDX
PR1_PRU1_GPO11/PR1_PRU1_GPI11/MCBSP_FSX/GPIO1_37	E15	SOC_MCBSPFSX
PR1_PRU1_GPO12/PR1_PRU1_GPI12/MCBSP_CLKX/GPIO1_38	B16	SOC_MCBSPCLKX
PR1_PRU1_GPO13/PR1_PRU1_GPI13/MCBSP_FSR/GPIO1_39	C16	SOC_MCBSPFSR
PR1_PRU1_GPO14/PR1_PRU1_GPI14/MCBSP_CLKR/GPIO1_40	D17	SOC_MCBSPCLKR
GPMC_CSn2/TIM11/GPIO0_28	W23	SOC_TIM1 33
GPMC_CSn3/TIMO1/GPIO0_29	Y25	SOC_TIMO1 33

DNI

SoC PWM

U1-23		
eHRPWM		
eHRPWM3_A/PR0_EDIO_DATA3/GPIO0_73	A23	SOC_EHRPWM3A
eHRPWM3_B/PR0_EDIO_DATA2/GPIO0_74	B22	SOC_EHRPWM3B
MII_TXER/PR0_eCAP0_eCAP_SYNCIN/GPIO0_96/eHRPWM_TZn3	H24	SOC_EHRPWM_TRIPZONE_INPUT3
eHRPWM3_SYNC0/PR0_EDIO_DATA0/GPIO0_76	D23	SOC_EHRPWM3_SYNC0
eHRPWM3_SYNC1/PR0_EDIO_DATA1/GPIO0_75	C22	SOC_EHRPWM3_SYNC1
PR1_PRU0_GPO18/PR1_PRU0_GPI18/PR1_EDC_LATCH0_IN/GPIO1_24/eHRPWM4_A	D12	SOC_EHRPWM4A
PR1_PRU0_GPO19/PR1_PRU0_GPI19/PR1_EDC_SYNC0_OUT/GPIO1_25/eHRPWM4_B	D13	SOC_EHRPWM4B
PR1_PRU0_GPO17/PR1_PRU0_GPI17/GPIO1_23/eHRPWM_TZn4/eHRPWM_SOCA	E13	SOC_EHRPWM_TRIPZONE_INPUT4
PR1_PRU1_GPO18/PR1_PRU1_GPI18/PR1_EDC_LATCH1_IN/GPIO1_44/eHRPWM5_A	E17	SOC_EHRPWM5A
PR1_PRU1_GPO19/PR1_PRU1_GPI19/PR1_EDC_SYNC1_OUT/GPIO1_45/eHRPWM5_B	E16	SOC_EHRPWM5B
PR1_PRU1_GPO17/PR1_PRU1_GPI17/GPIO1_43/eHRPWM_TZn5/eHRPWM_SOCB	F16	SOC_EHRPWM_TRIPZONE_INPUT5
PR1_MDIO_MDCLK/GPIO1_47/eCAP1_IN_APWM1_OUT	D18	SOC_ECAP1_IN_PWM1_OUT

DNI

SERIAL EXPANSION CONNECTOR

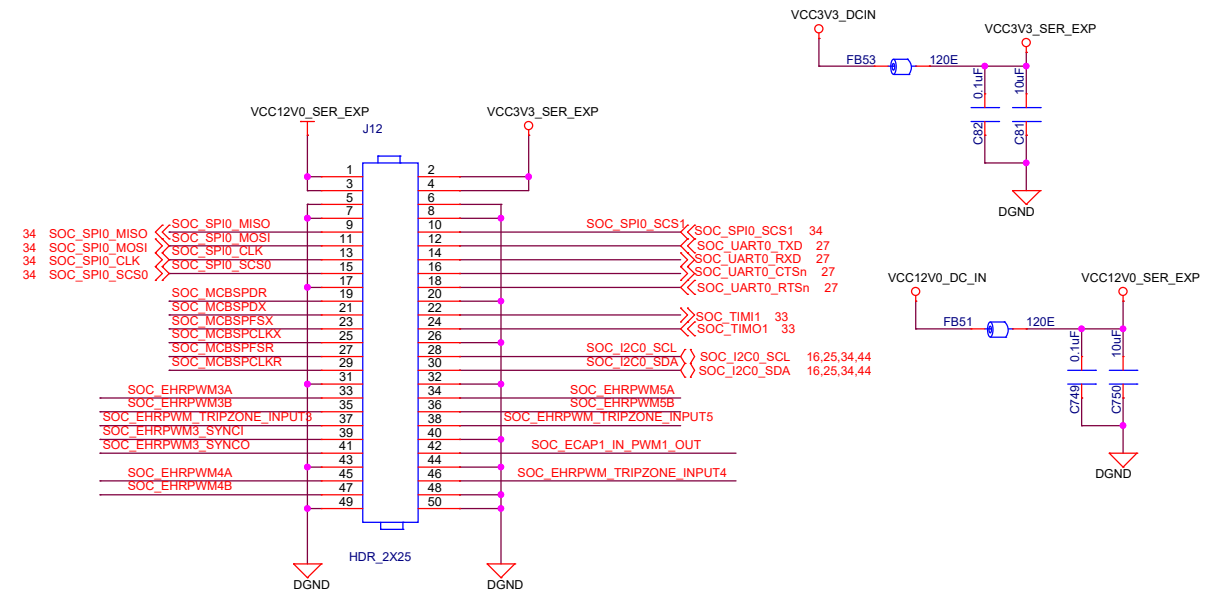

Designed for T1 by Mistral Solutions Pvt Ltd



Title SERIAL & EHRPWM EXP CONNECTOR

Size	Variant Name = Proj PROC046 002 OPN# EVMK2GXS	Rev
C		A

Date: Friday, February 02, 2018 Sheet 33 of 51

I2C0

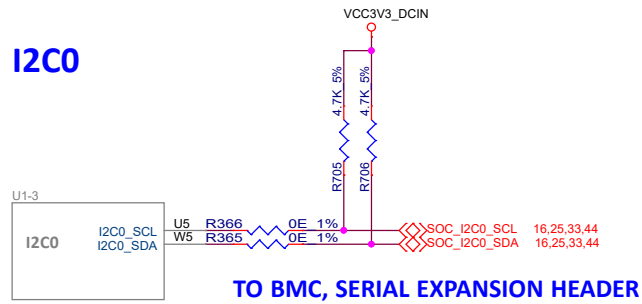

SoC I2C

I2C2

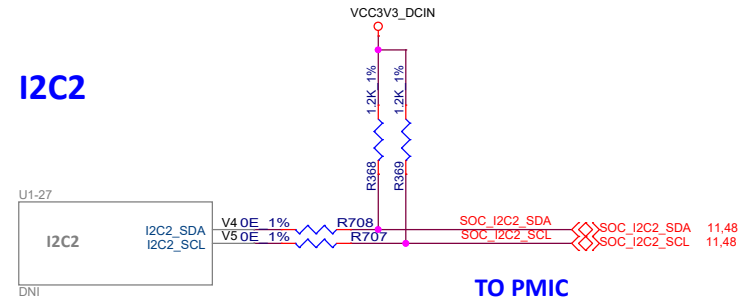

I2C1

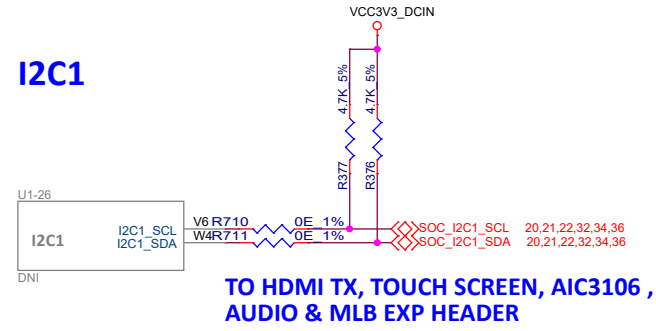

TEMPERATURE SENSOR

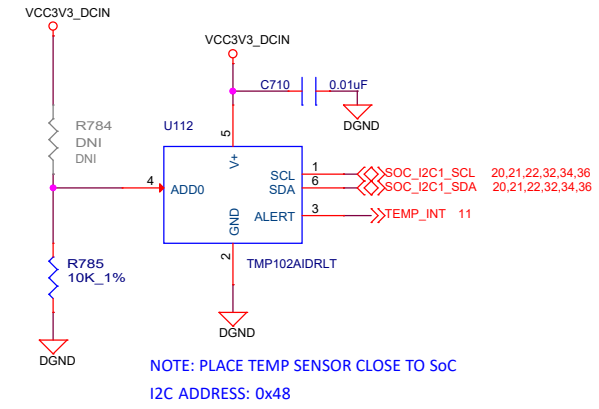

SoC SPI

SPIO

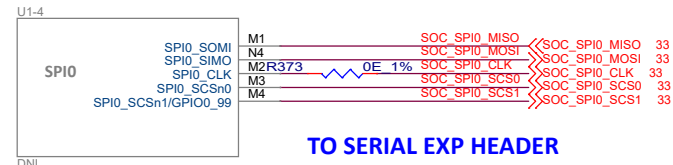

GPIO EXPANDER & LEDs

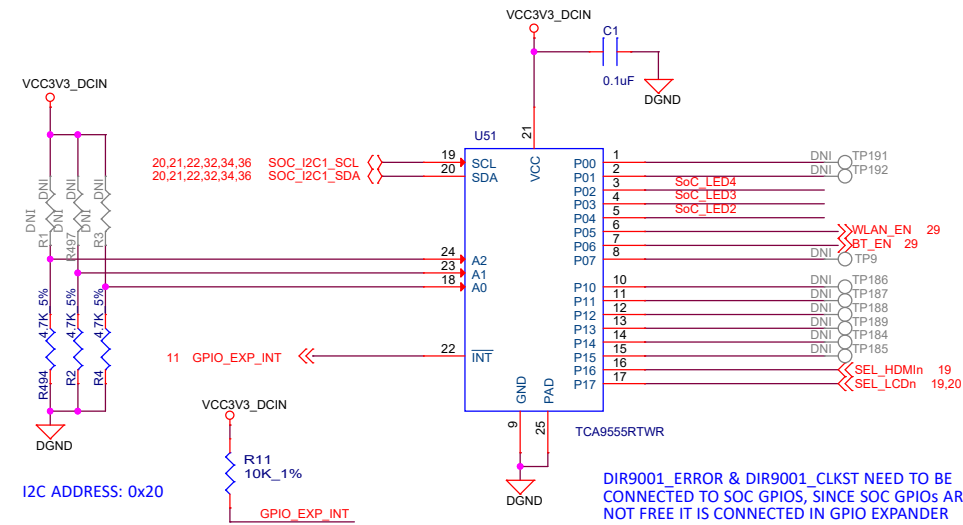

SPI2

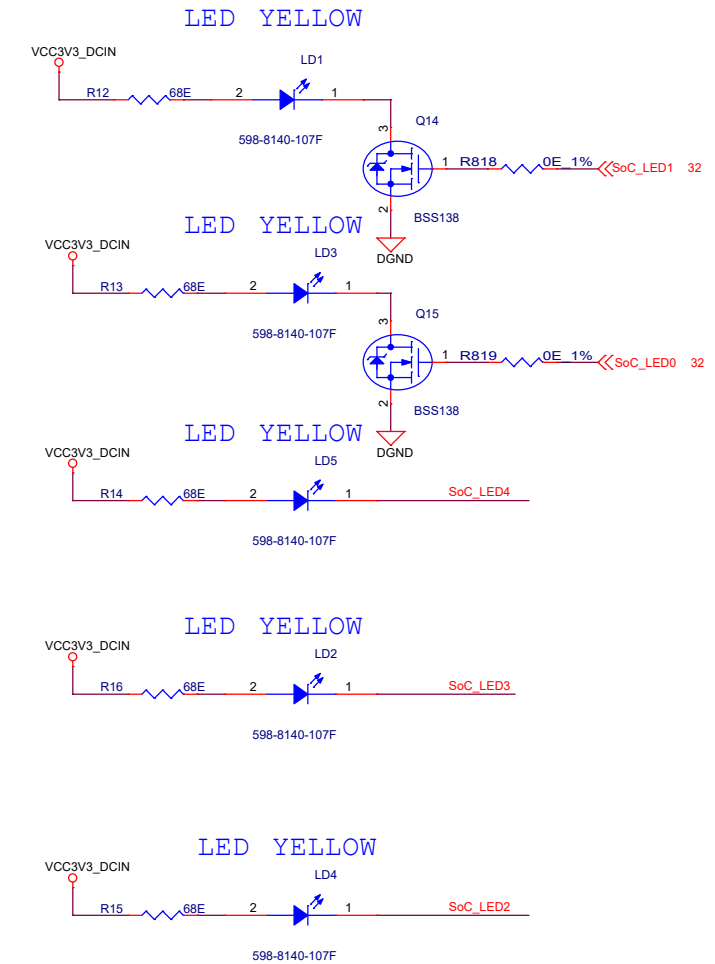
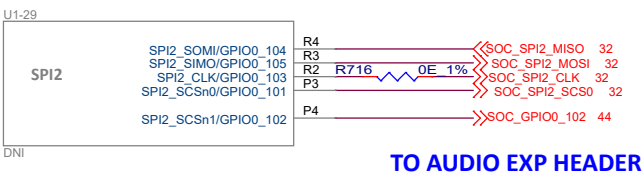

CLOCK GENERATOR

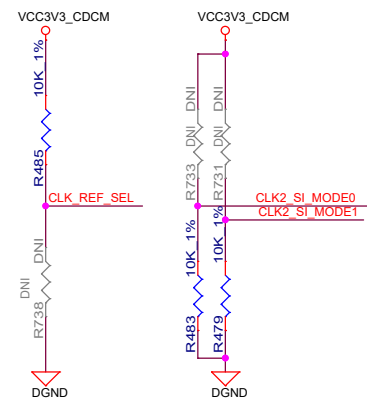

MODE SELECTION FOR CDCM DEVICE

SI_MODE1	SI_MODE0	MODE SELECTED
0	0	SPI MODE
0	1	I2C MODE
1	0	PIN MODE (NO SERIAL PROGRAMMING)
1	1	RESERVED

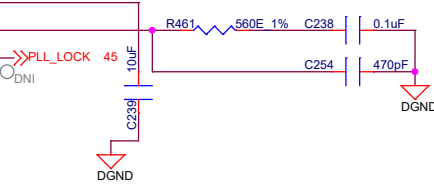
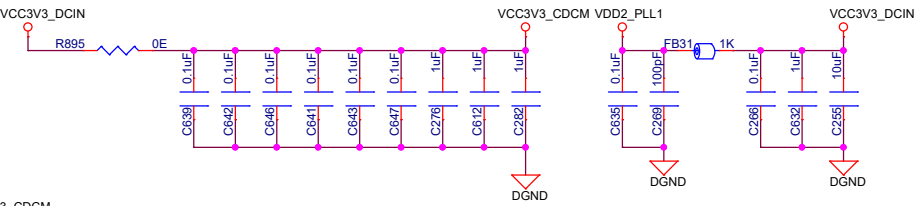
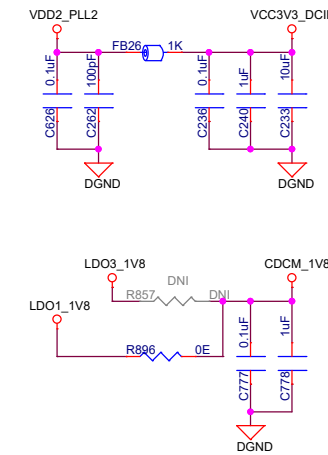
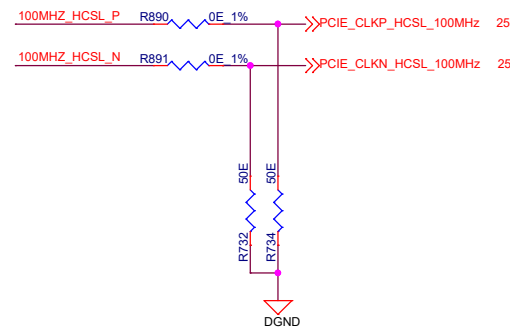
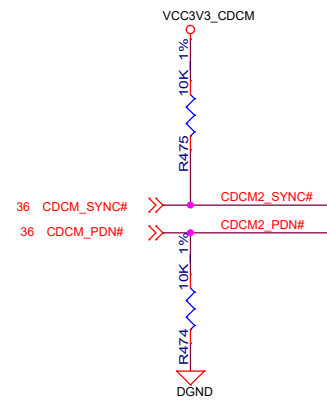
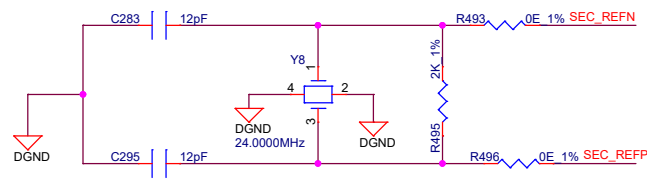
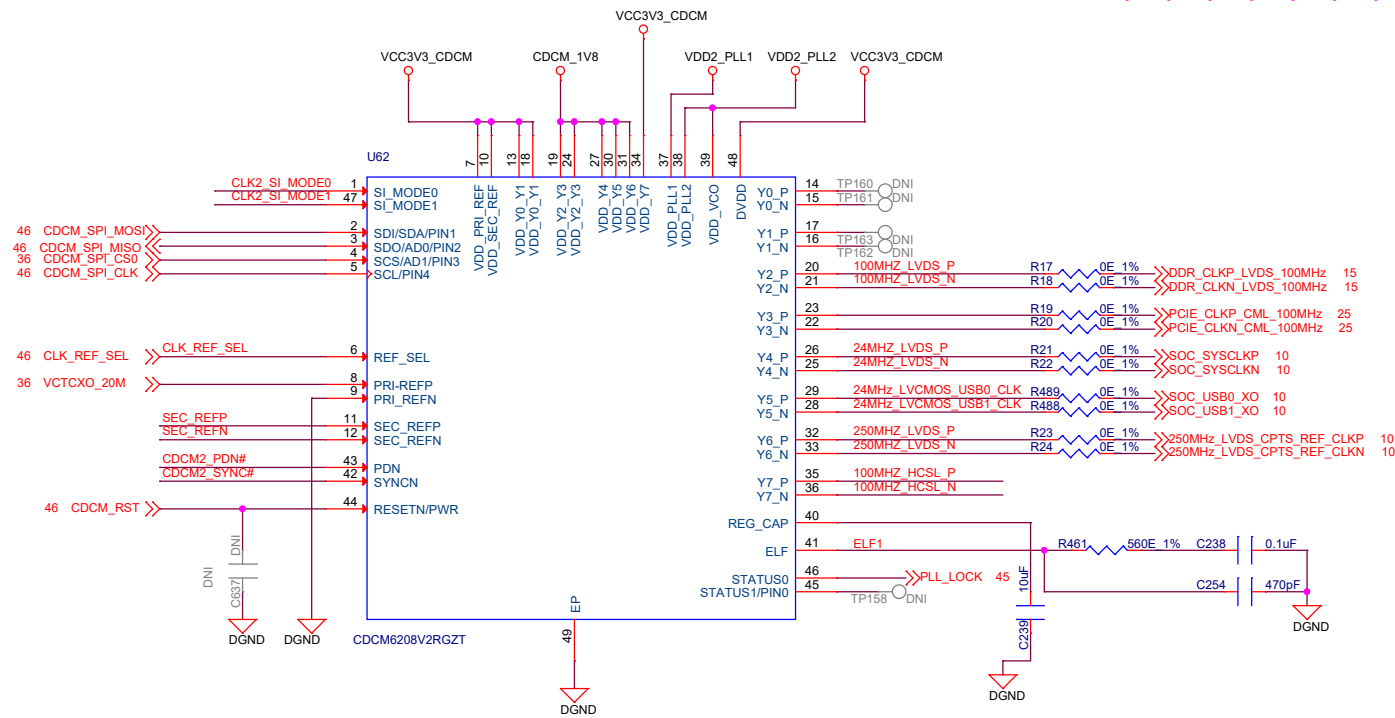

BMC ISOLATOR 5

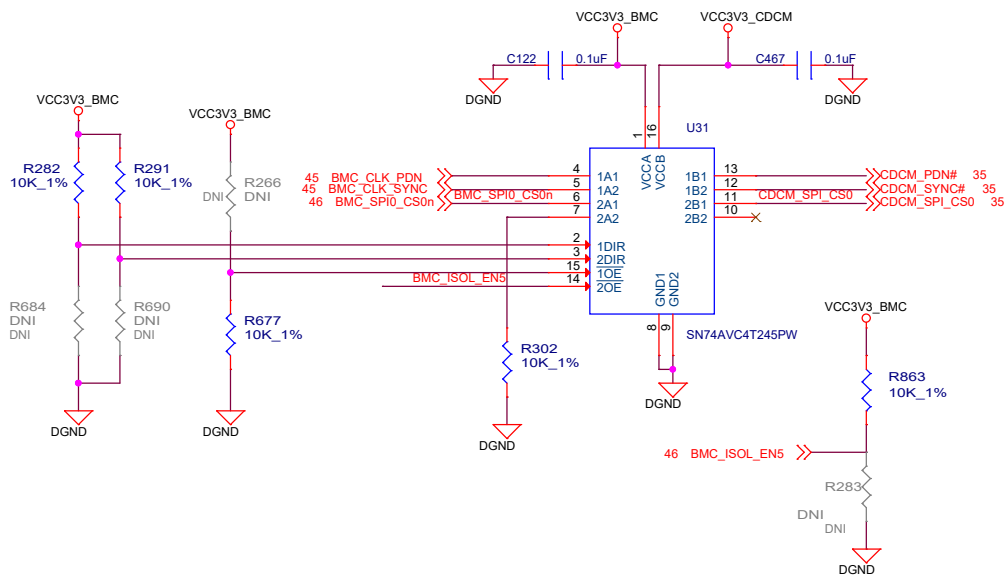

GENERATOR - AUDIO CLOCK DOMAIN

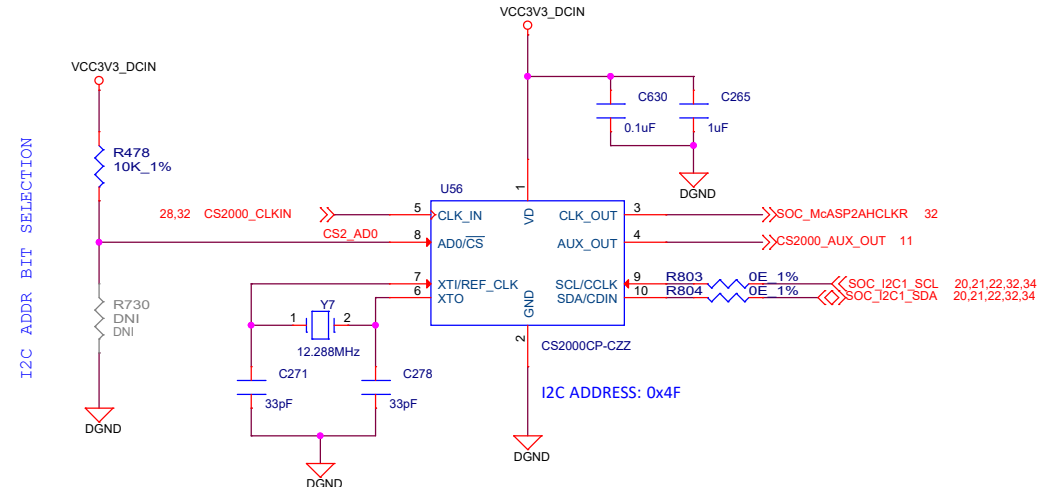

SoC SPI3

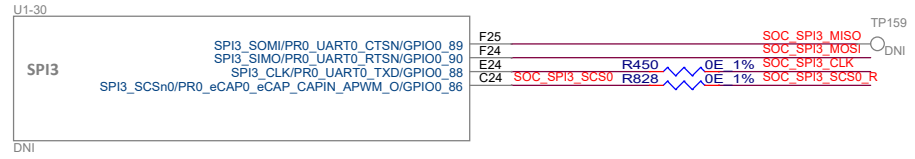

AVB CLOCK GENERATOR- 1588 CLOCK DOMAIN

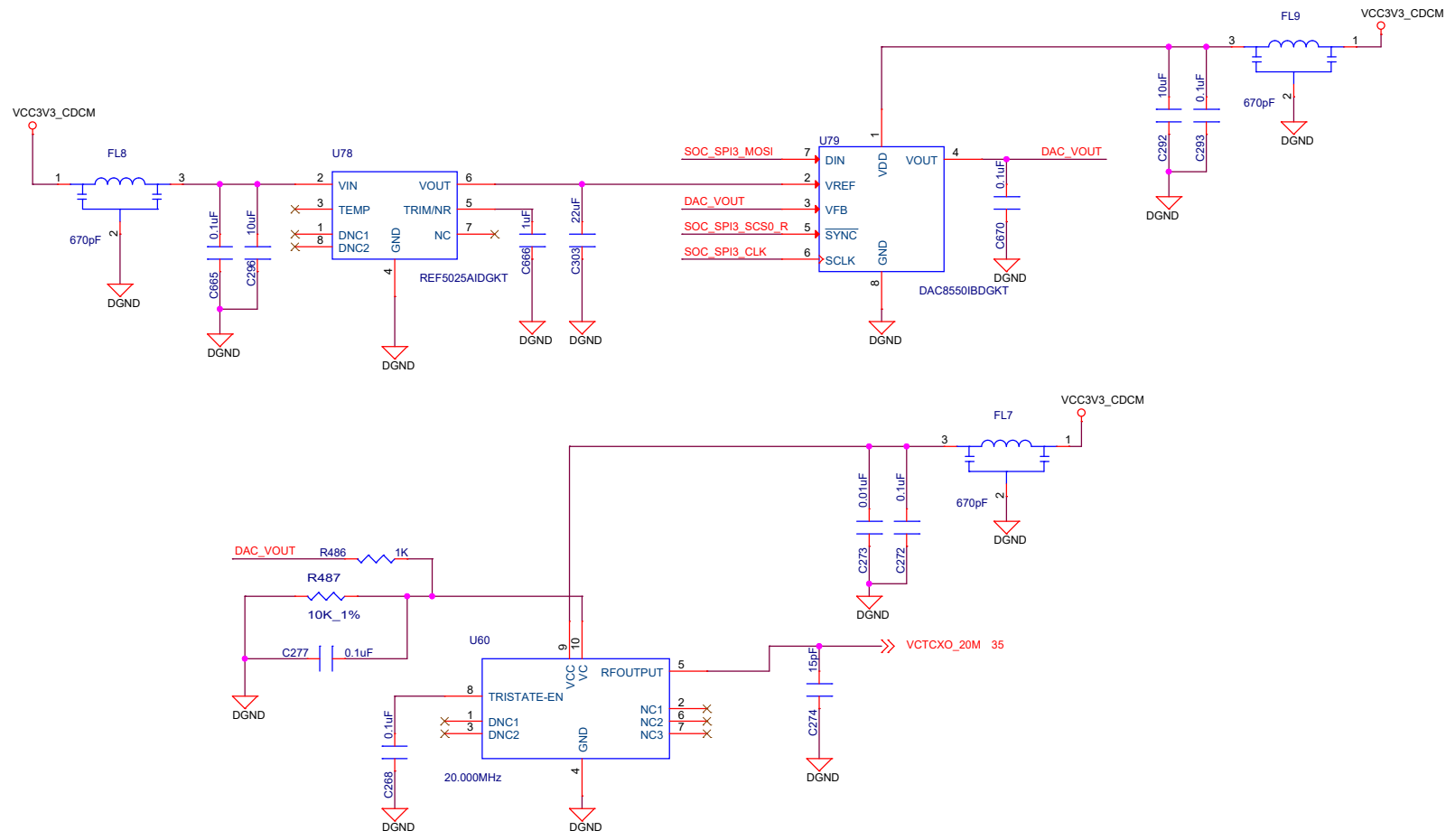

Designed for T1 by Mistral Solutions Pvt Ltd



Title		CLOCK DISTRIBUTION 2	
Size	Variant Name = Proj PROC046 002 OPN# EVMK2GXS	Rev	A
Date:	Friday, February 02, 2018	Sheet	36 of 51

MIPI 60

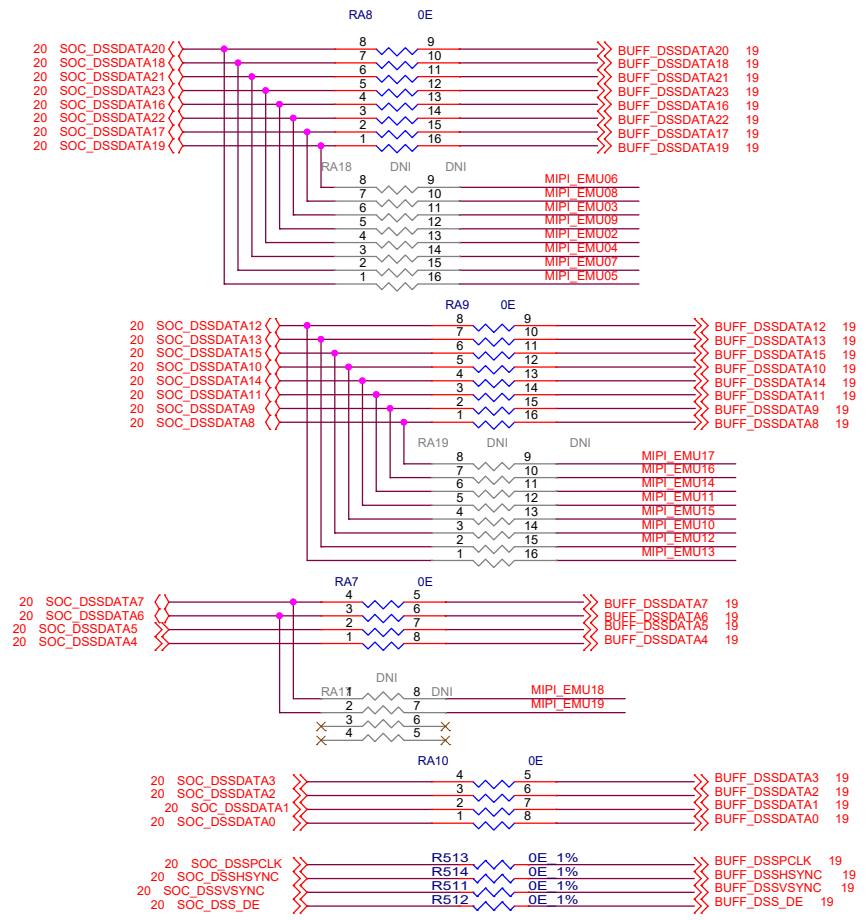
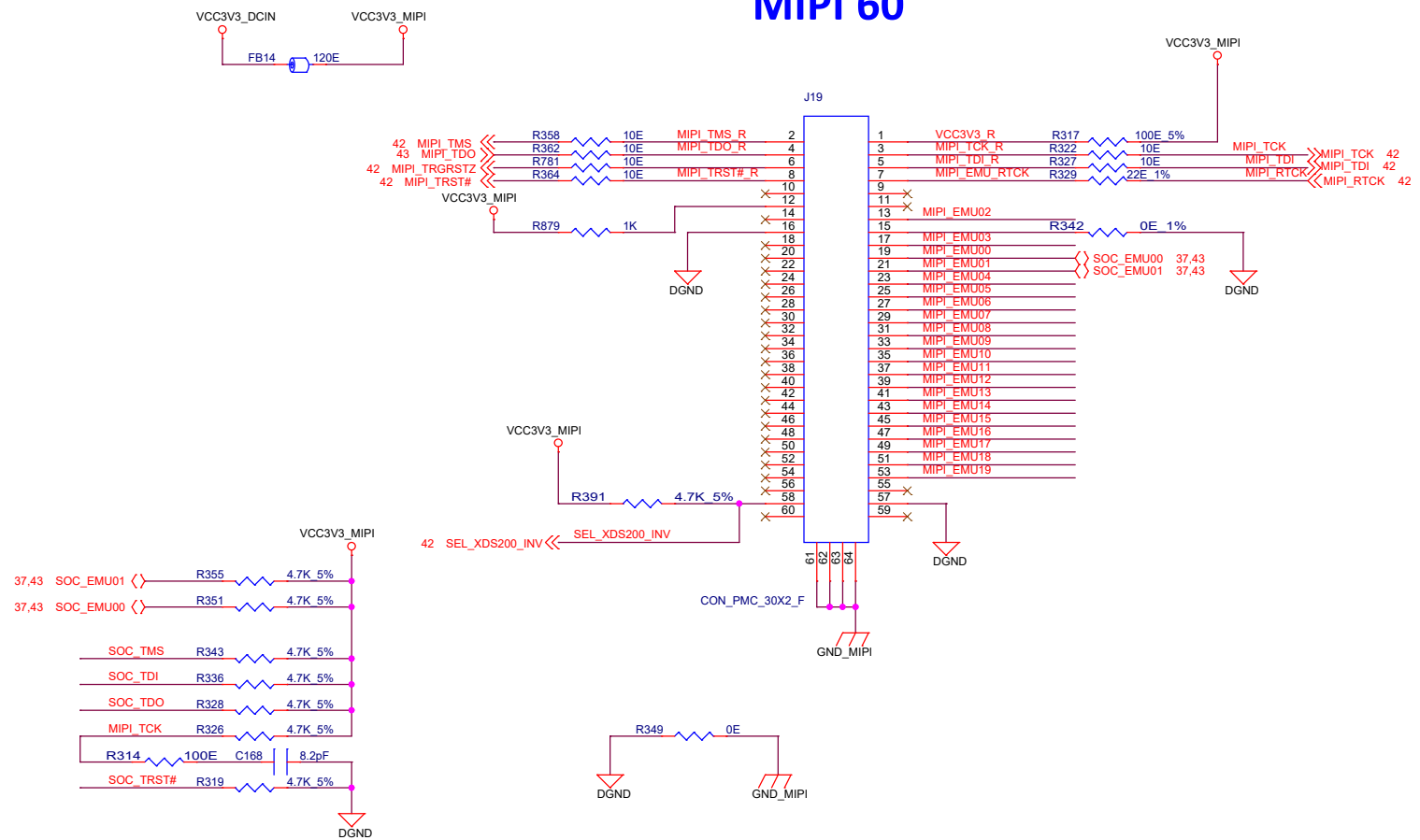

Res MUX between Display and JTAG TRACE Functionality
 -For display, install RA7, RA8 & RA9 . DNI RA17,RA18 & RA19
 -For TRACE, install RA17, RA18 & RA19. DNI RA7, RA8 & RA9

SoC JTAG

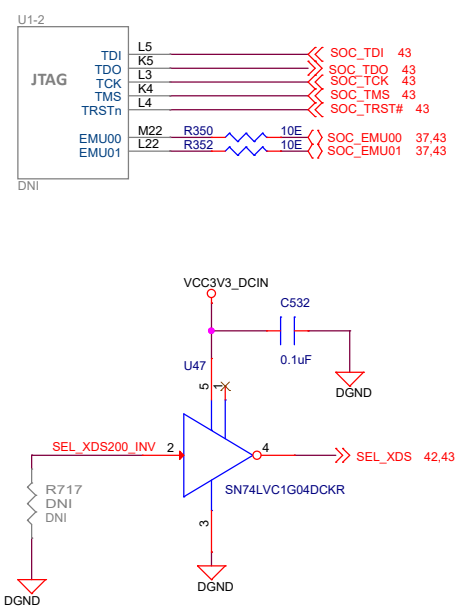

BOOTMODE

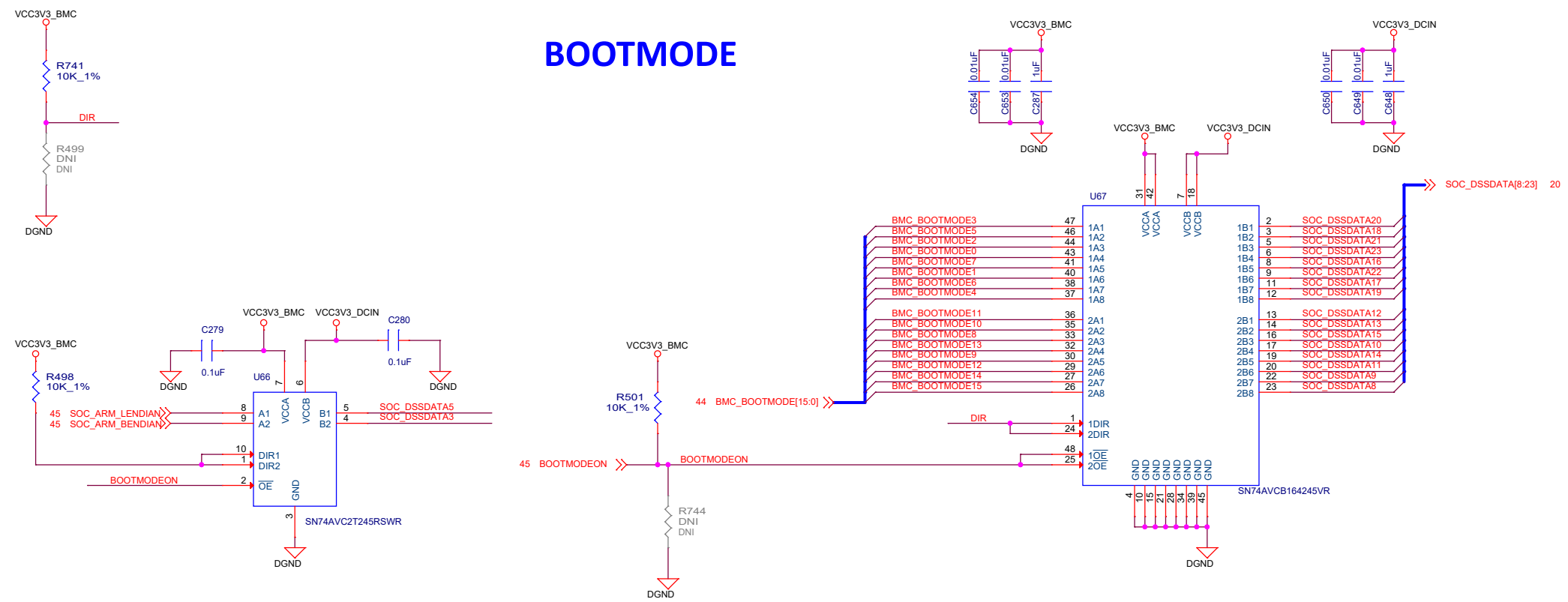

Designed for T1 by Mistral Solutions Pvt Ltd



Title		EMU & MIPI60 CONNECTOR	
Size	Variant Name = Proj PROC046 002 OUP# EVMK2GX5	Rev	
C		A	
Date:	Friday, February 02, 2018	Sheet	37 of 51

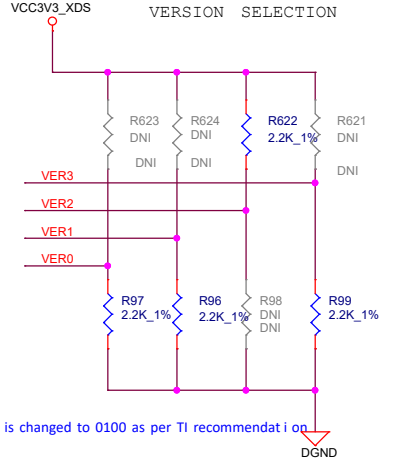
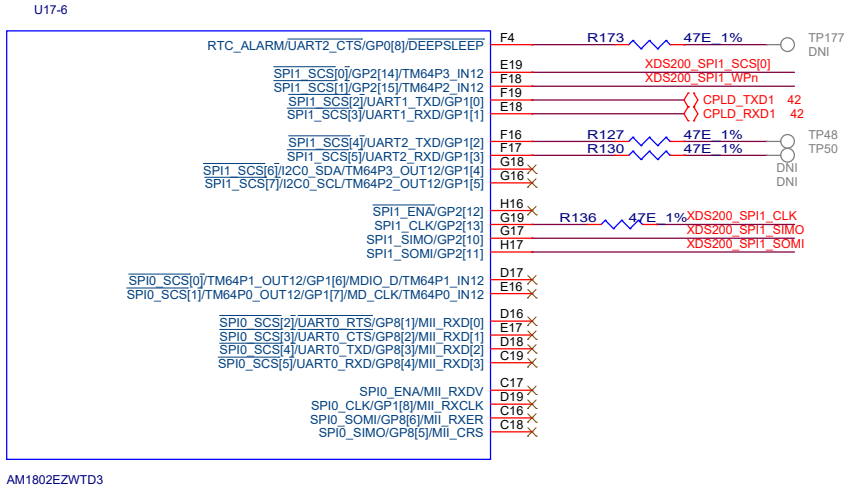
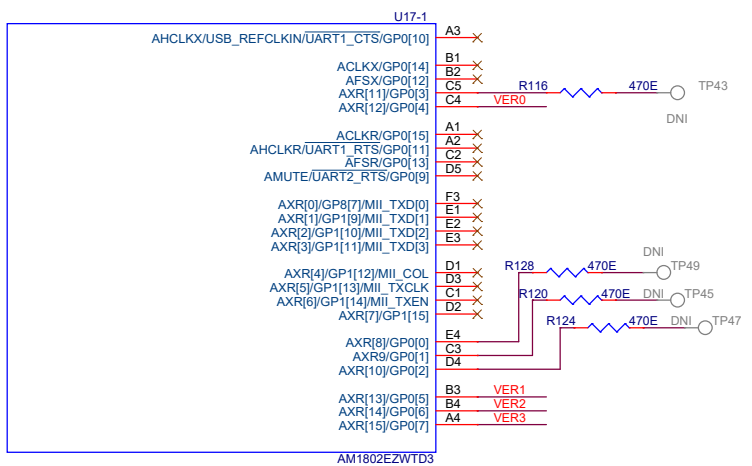

Note: Version Code default value is changed to 0100 as per TI recommendat i on

XDS200

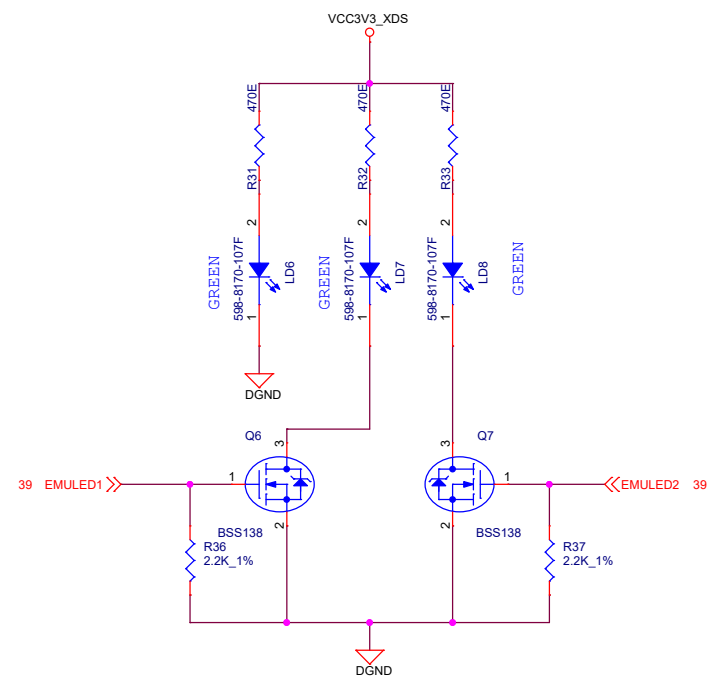
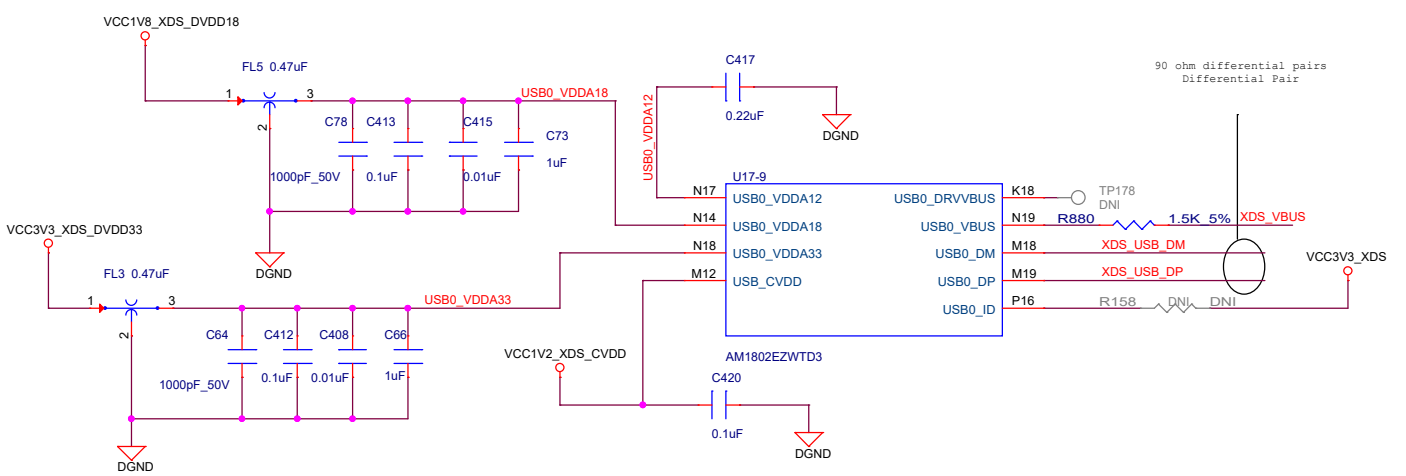

MINI USB CONN

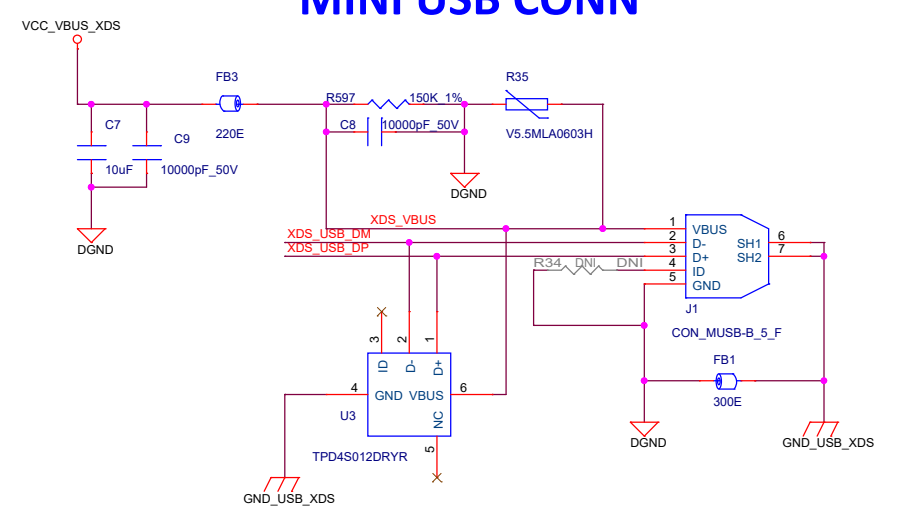
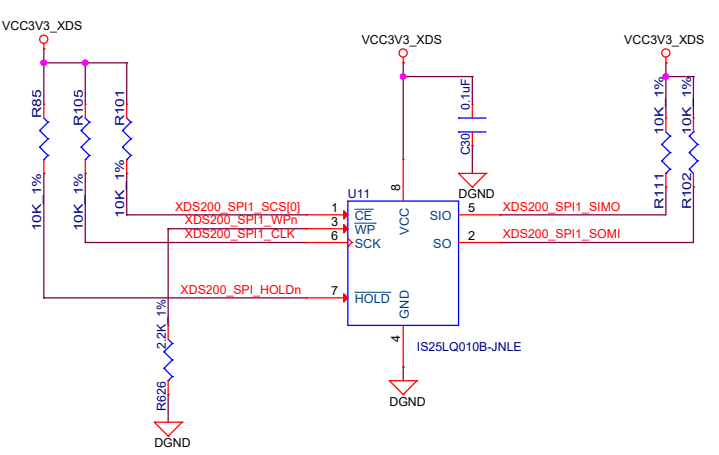

Designed for TI by Mistral Solutions Pvt Ltd



Title		XDS200
Size	Variant Name = Proj PROC046 002 OUP# EVMK2GXS	Rev
C		A
Date:	Friday, February 02, 2018	Sheet 38 of 51

XDS200

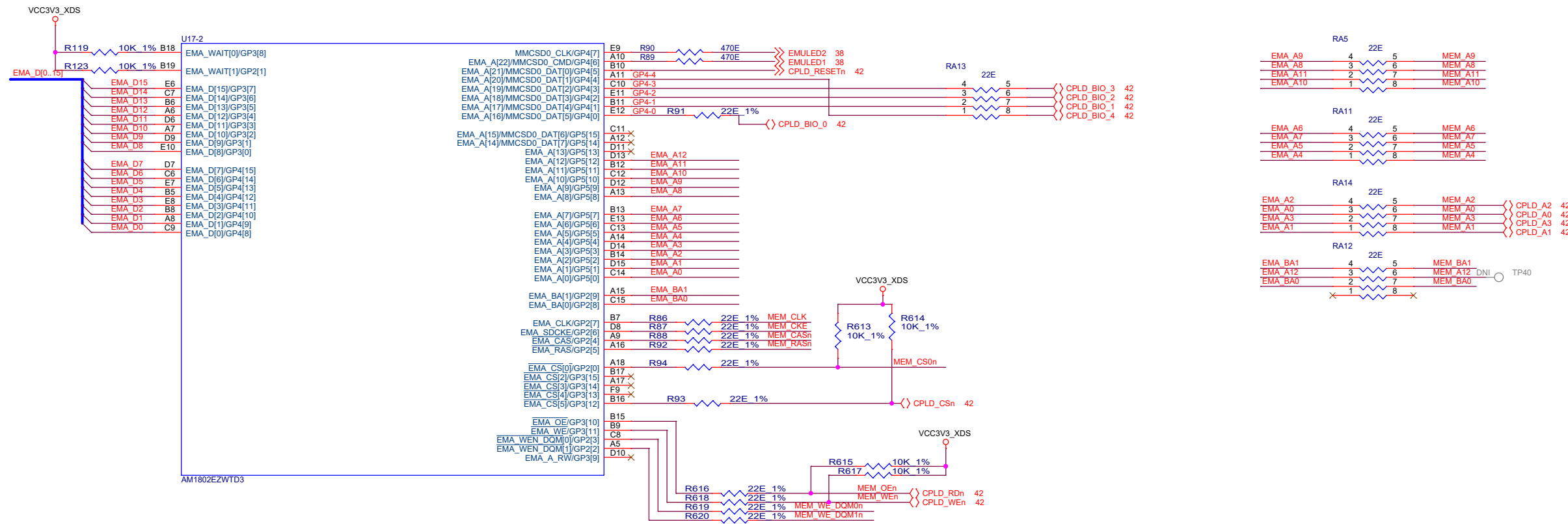

SDRAM

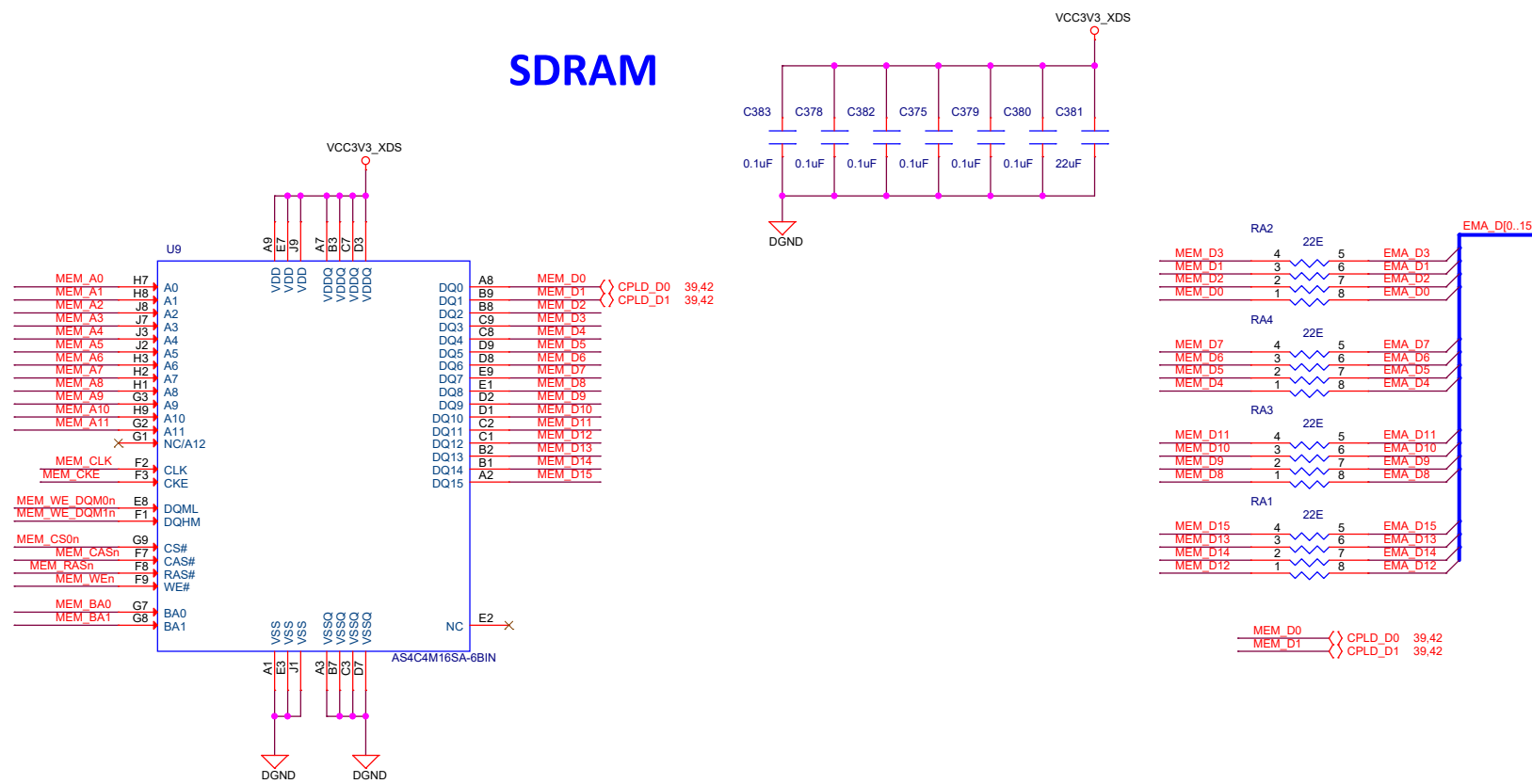

Designed for TI by Mistral Solutions Pvt Ltd



Title JTAG_XDS200_2

Size	Variant Name = Proj PROC046 002 OPN# EVMK2GX5	Rev
C		A
Date:	Friday, February 02, 2018	Sheet 39 of 51

XDS200

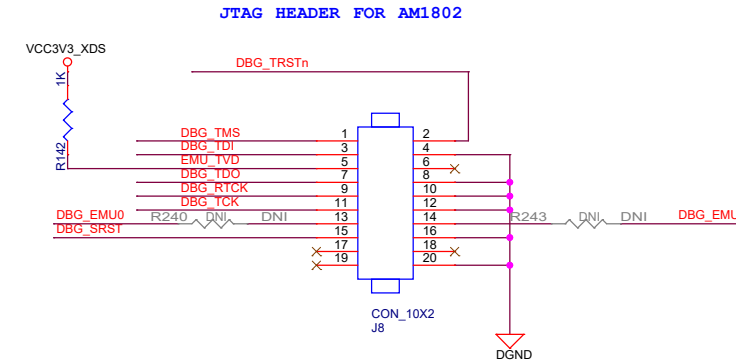
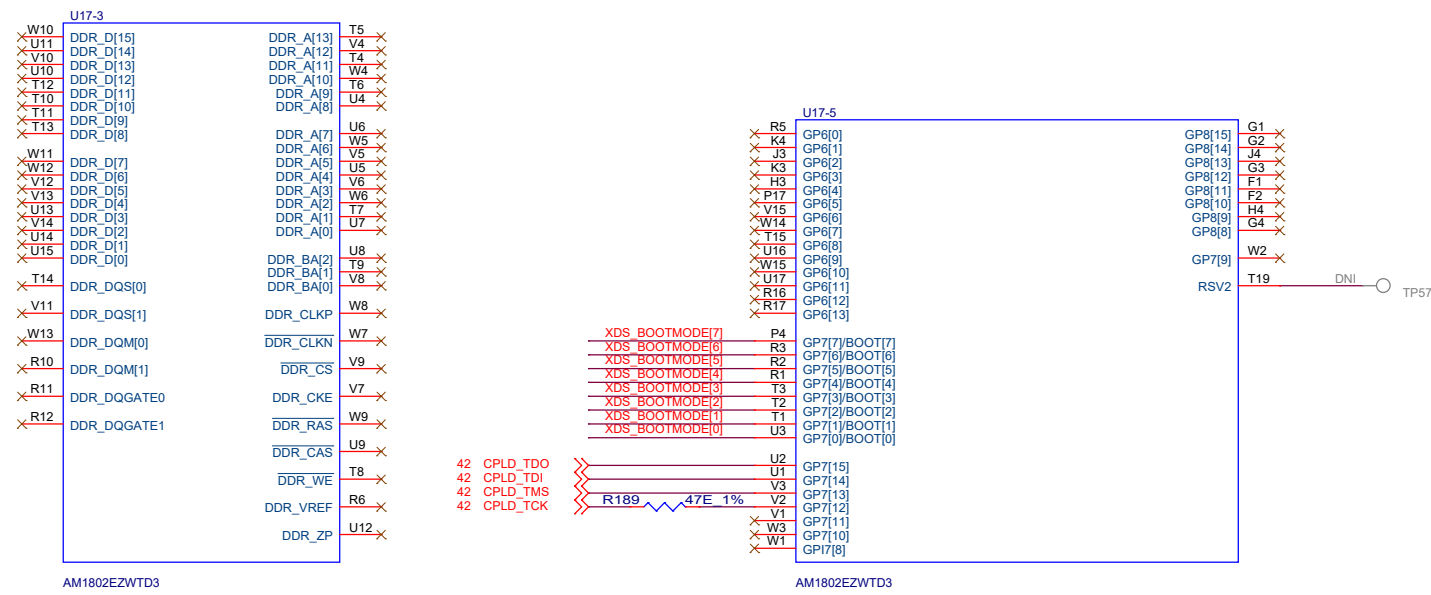

BOOTMODE: SPI1-FLASH ^B0001100

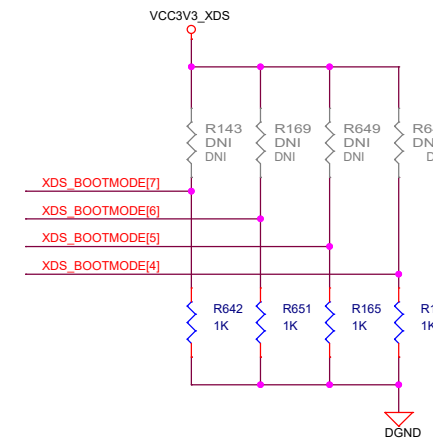

BOOT MODE

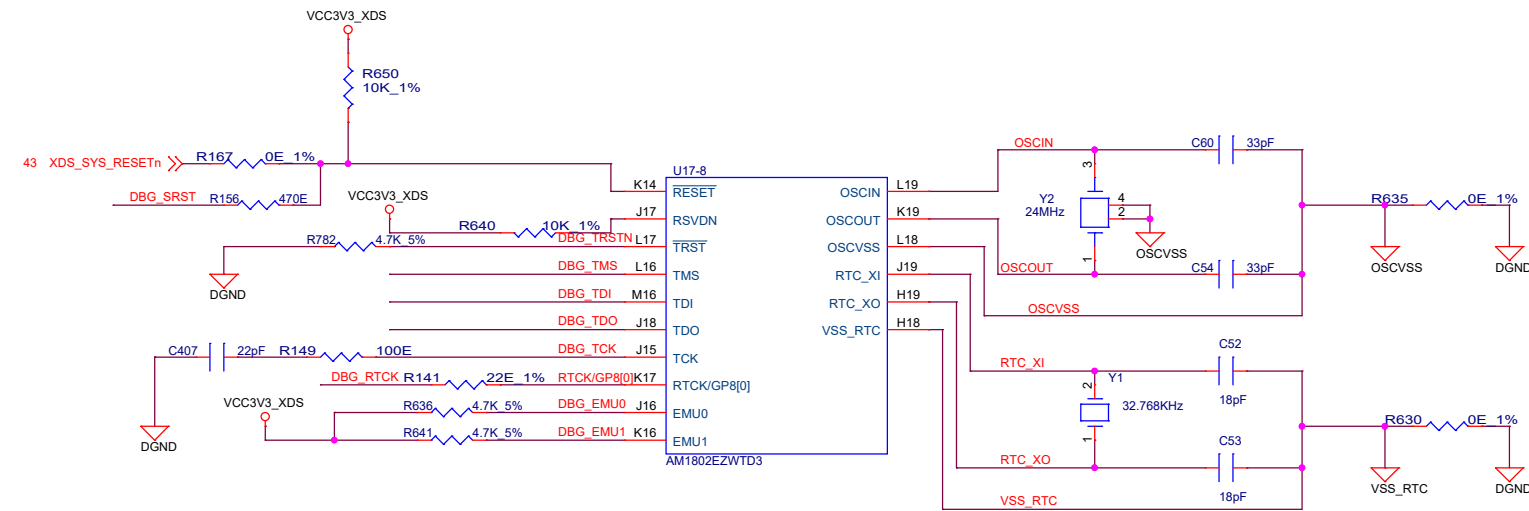
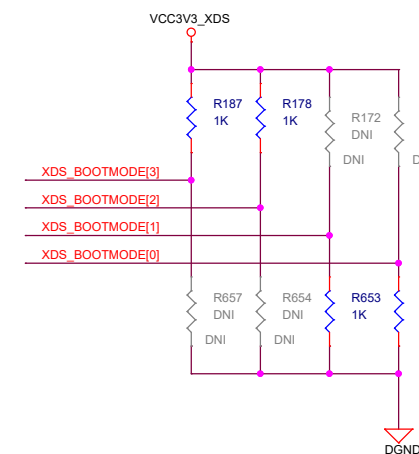

Designed for T1 by Mistral Solutions Pvt Ltd



Title JTAG_XDS200_3

Size Variant Name = Proj PROC046 002 OPN# EVMK2GXS Rev A

Date: Friday, February 02, 2018 Sheet 40 of 51

XDS200 DECAPS

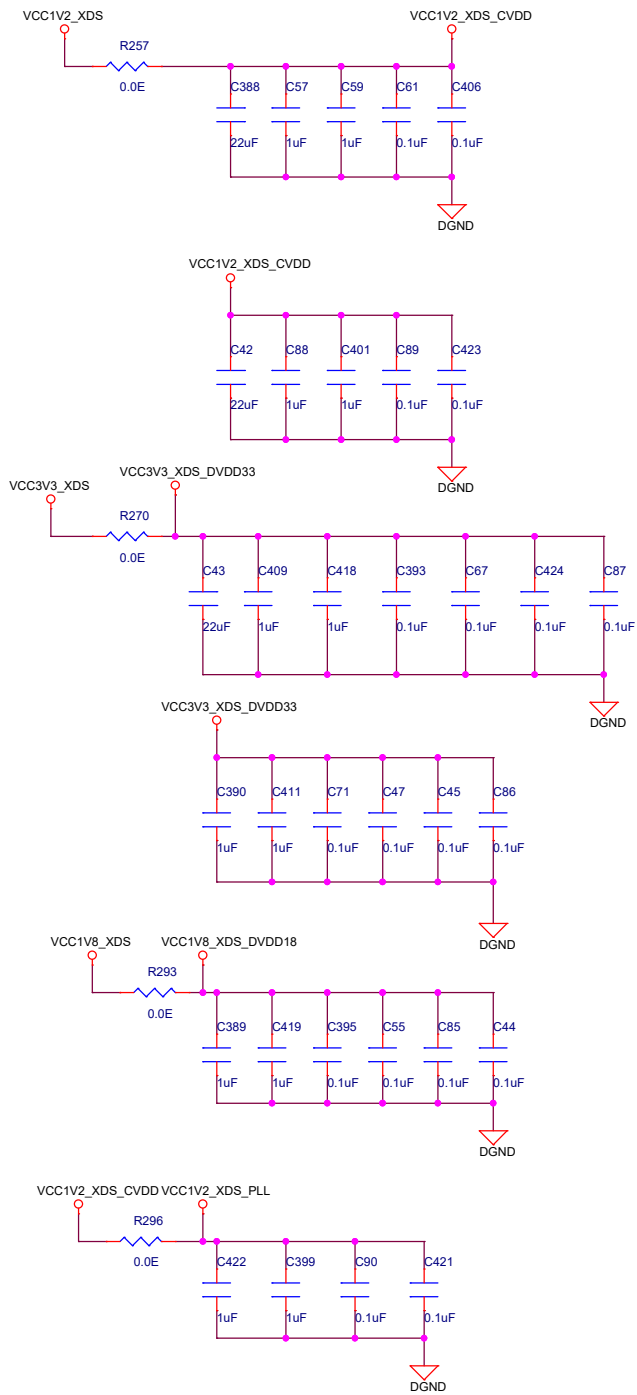

XDS200

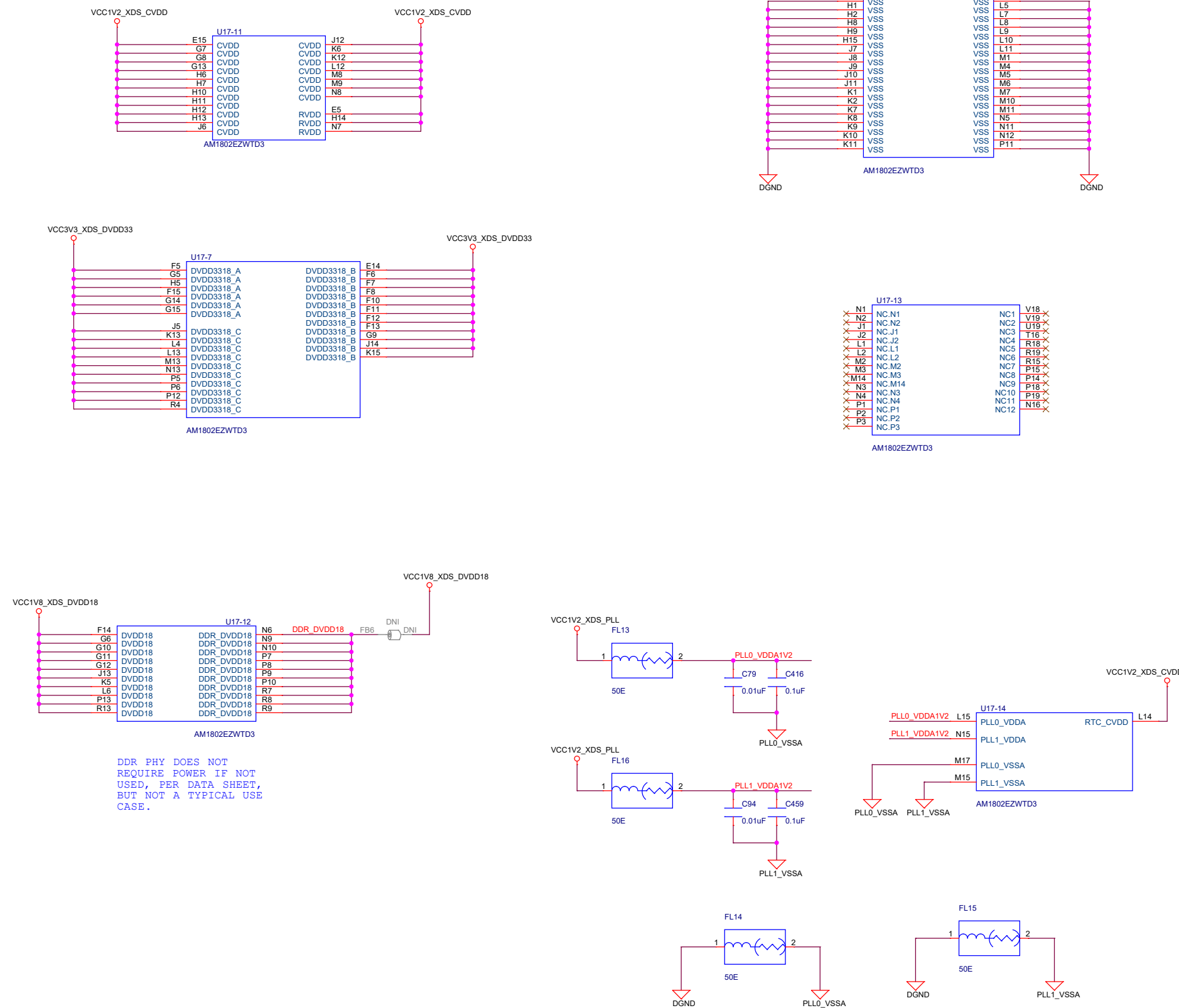

Designed for T1 by Mistral Solutions Pvt Ltd



Title		JTAG_XDS200_4	
Size	Variant Name = Proj PROC046 002 OPN# EVMK2GXS	Rev	
C		A	
Date:	Friday, February 02, 2018	Sheet	41 of 51

XDS200 CPLD

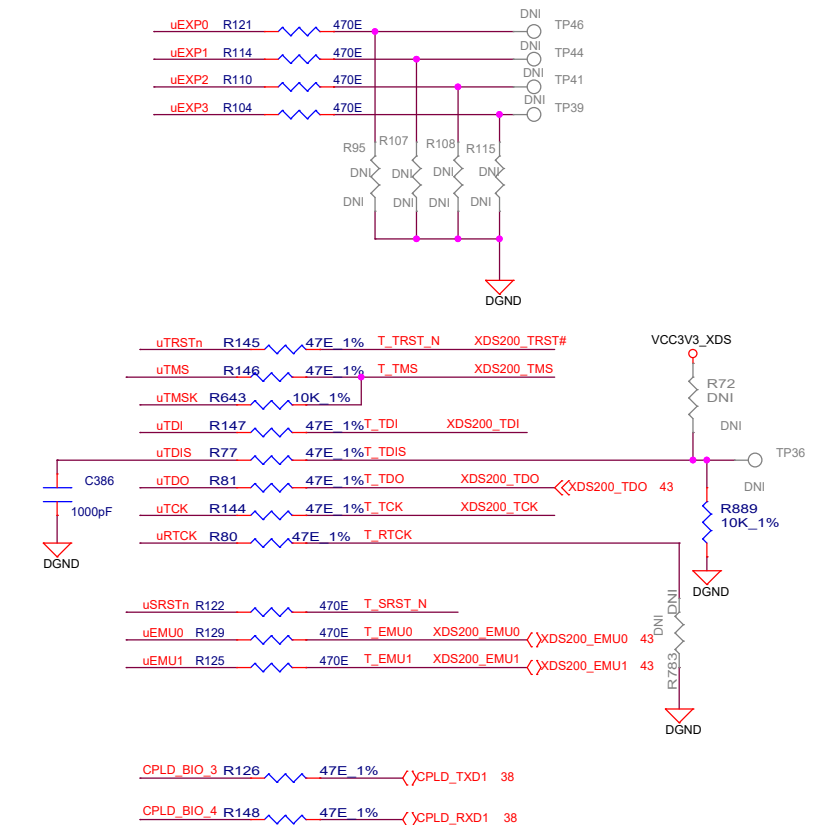
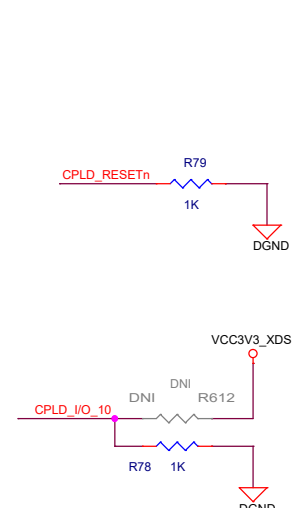
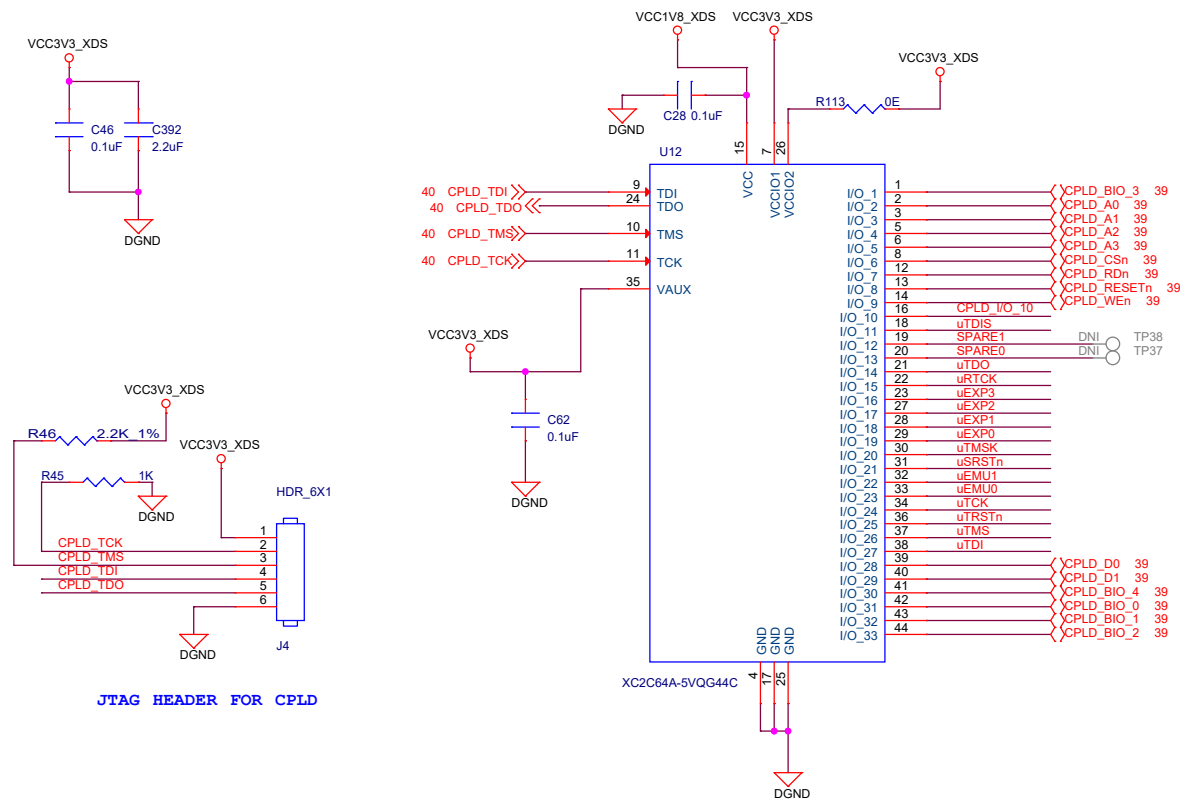

BUFFER XDS200

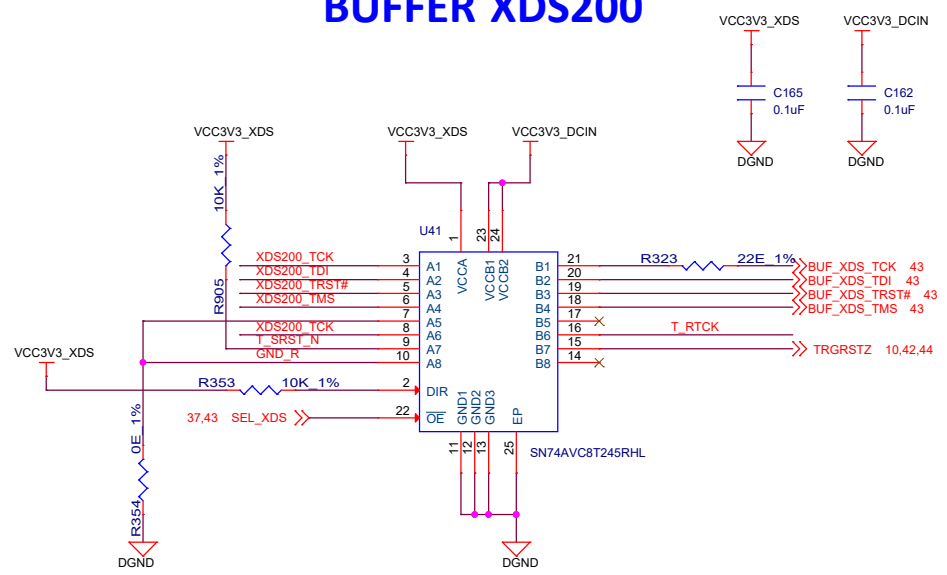

BUFFER MIPI

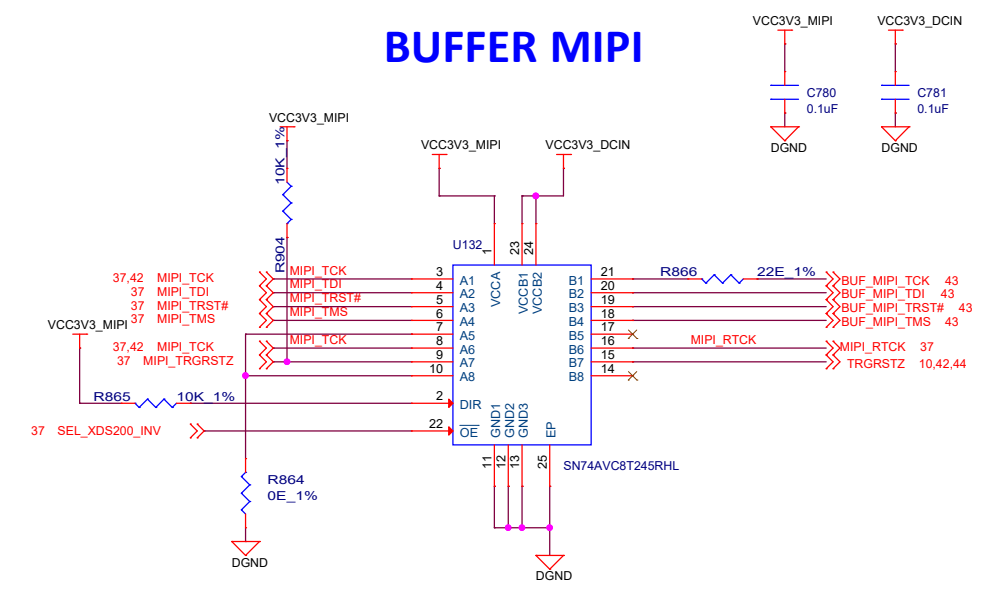

Designed for T1 by Mistral Solutions Pvt Ltd



Title		JTAG_XDS200_CPLD
Size	Variant Name = Proj PROC046 002 OPN# EVMK2GX5	Rev
C		A
Date:	Friday, February 02, 2018	Sheet 42 of 51

XDS200 POWER

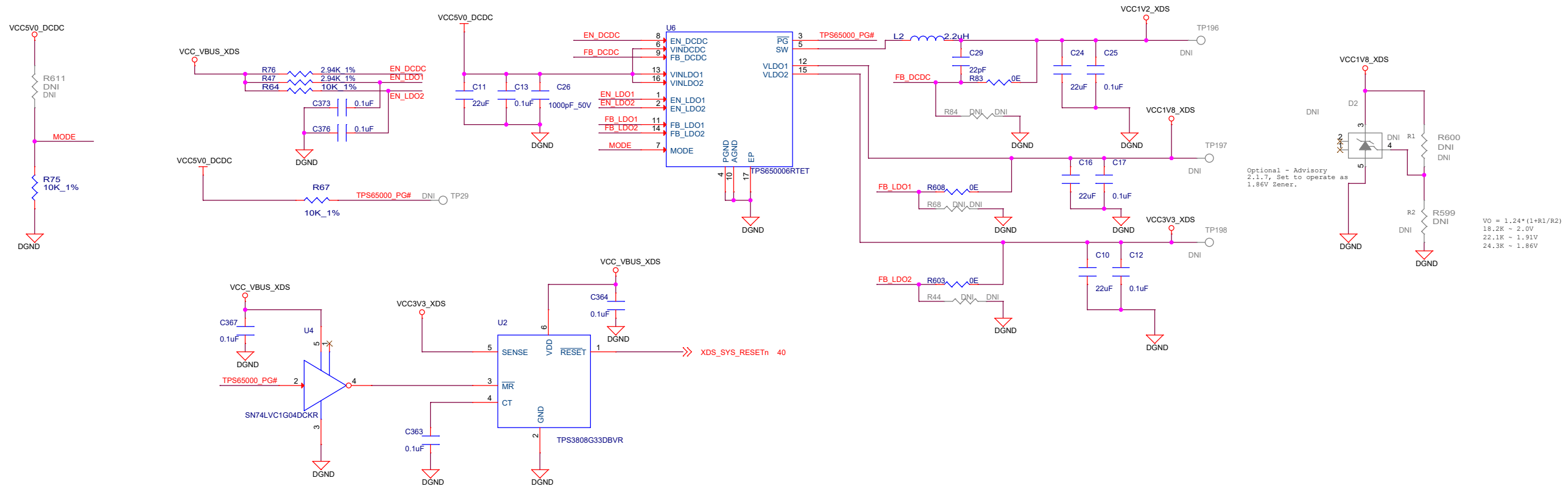

JTAG FET SWITCH

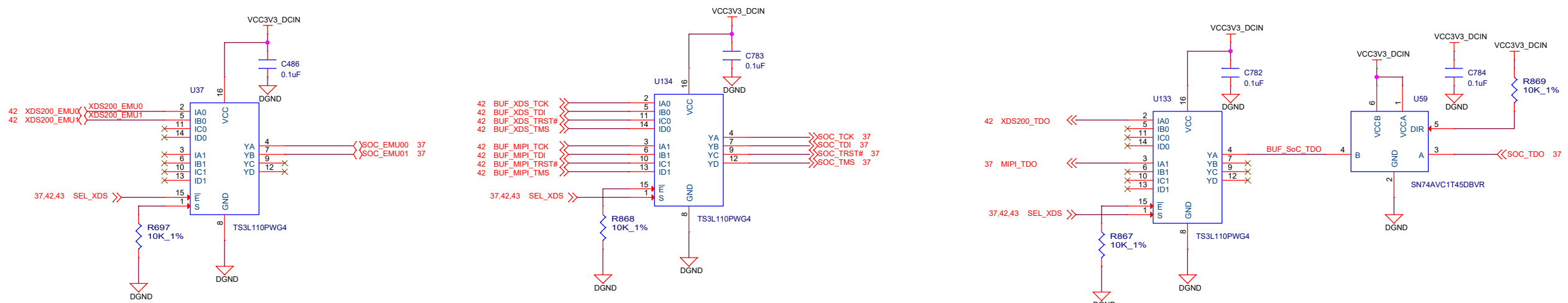

Designed for T1 by Mistral Solutions Pvt Ltd



Title XDS200 POWER

Size	Variant Name = Proj PROC046 002 OPN# EVMK2GXS	Rev
C		A
Date:	Friday, February 02, 2018	Sheet 43 of 51

BMC JTAG

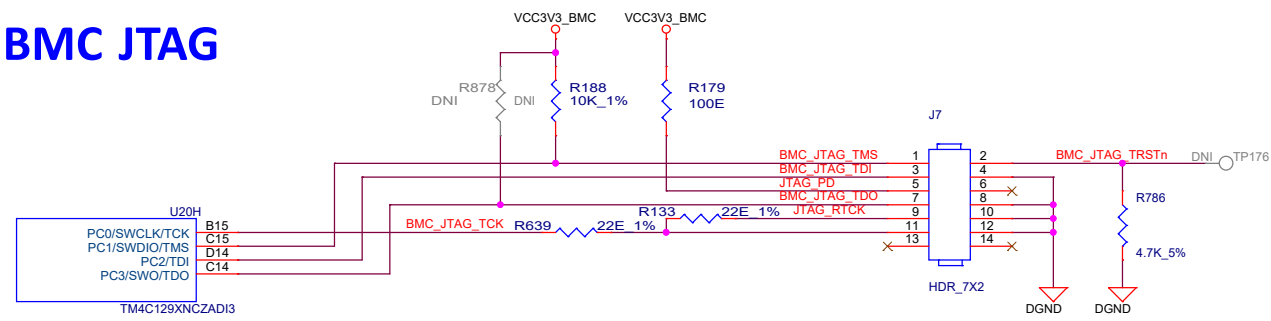

BMC I2C1

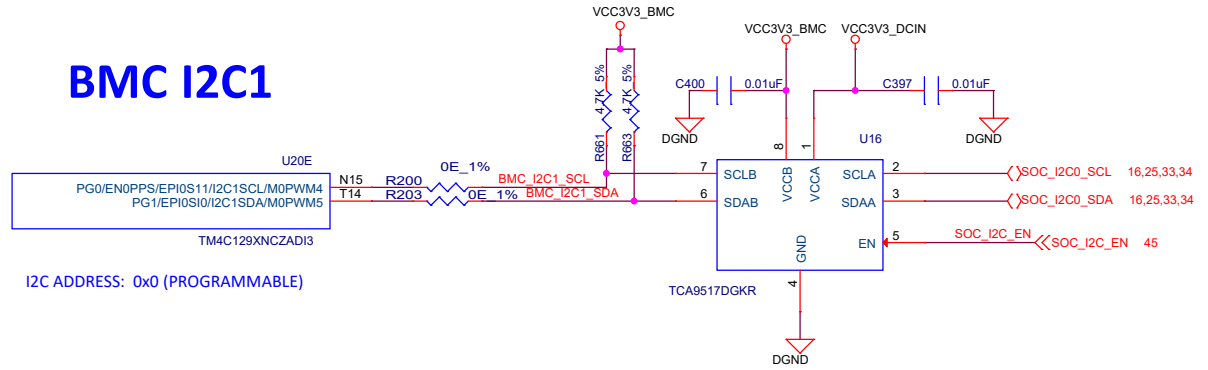

BMC LCD

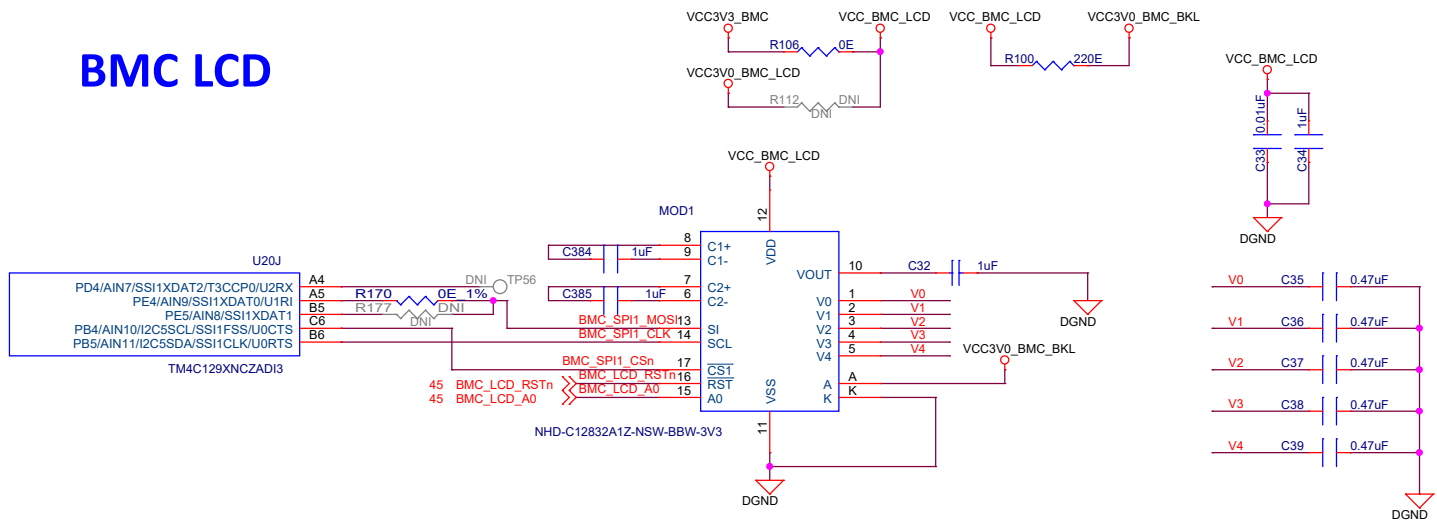

BMC I2C0

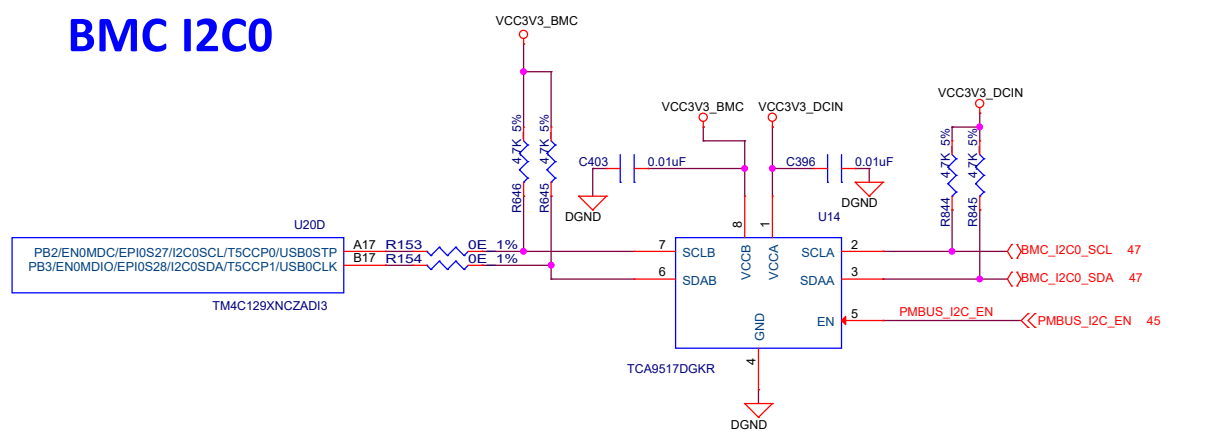

BMC TEST POINTS

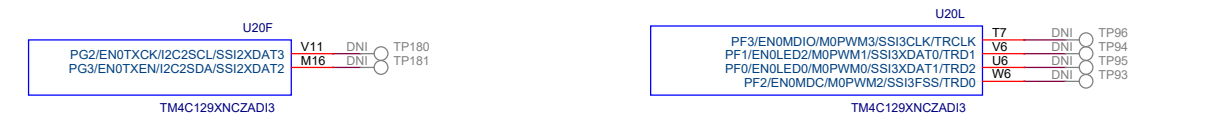

BMC

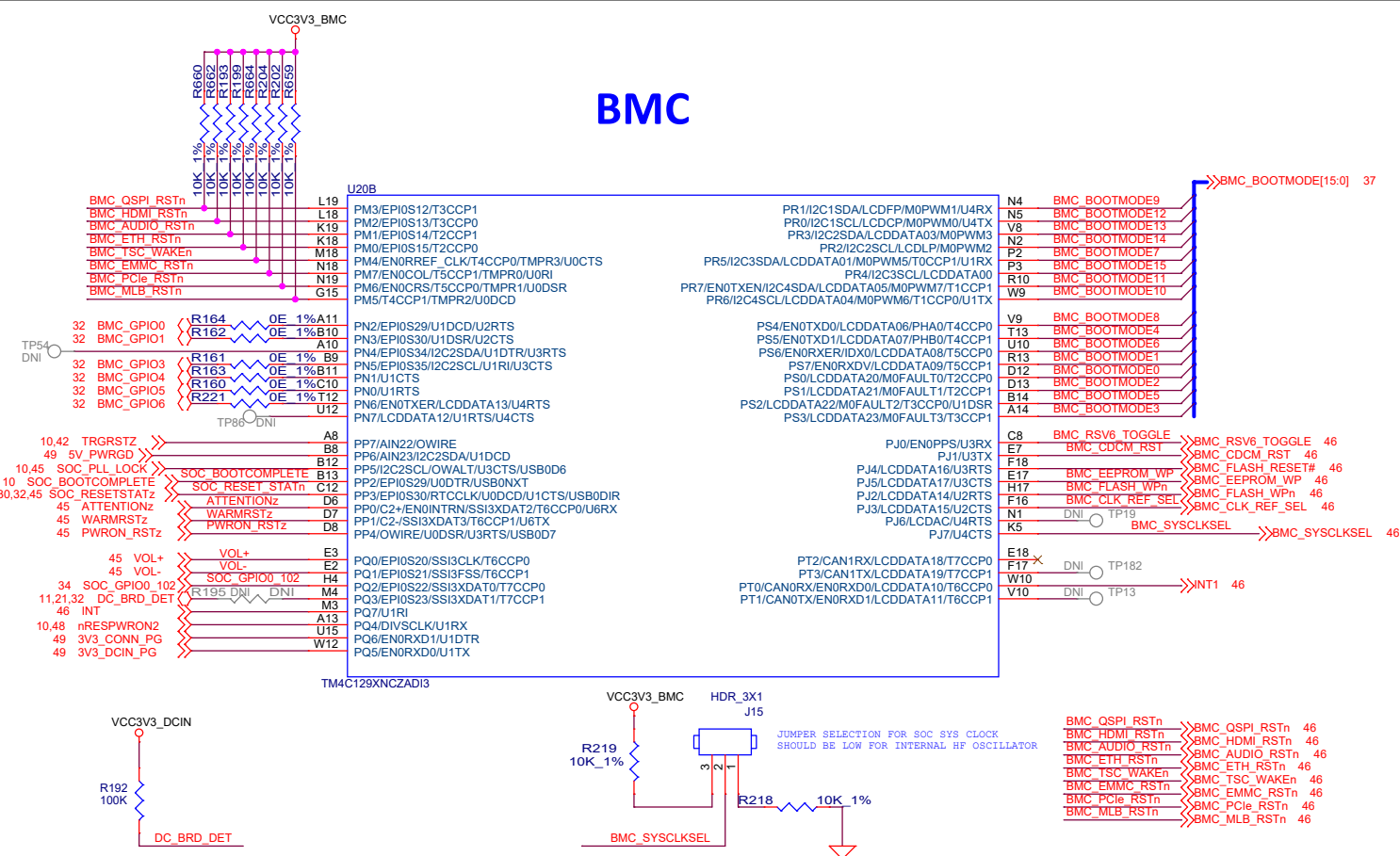

BMC UART0

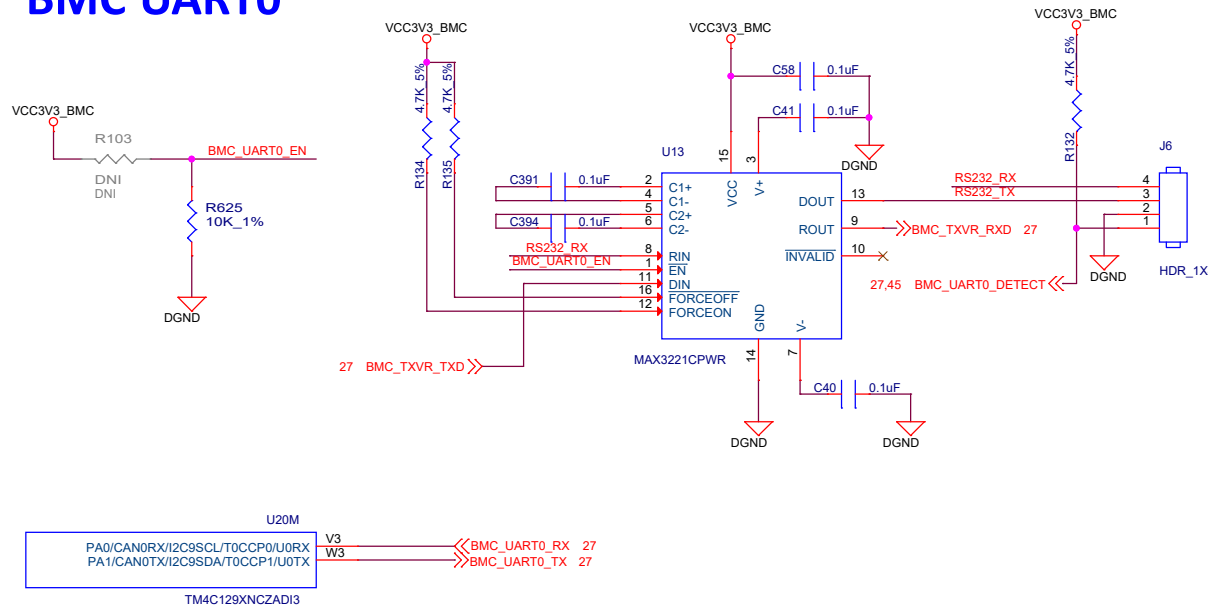

Designed for TI by Mistral Solutions Pvt Ltd



Title		BOARD MANAGEMENT CONTROL_1	
Size	Variant Name = Proj PROC046 002 ENPN# EVMK2GX5	Rev	A
Date:	Friday, February 02, 2018	Sheet	44 of 51

BMC

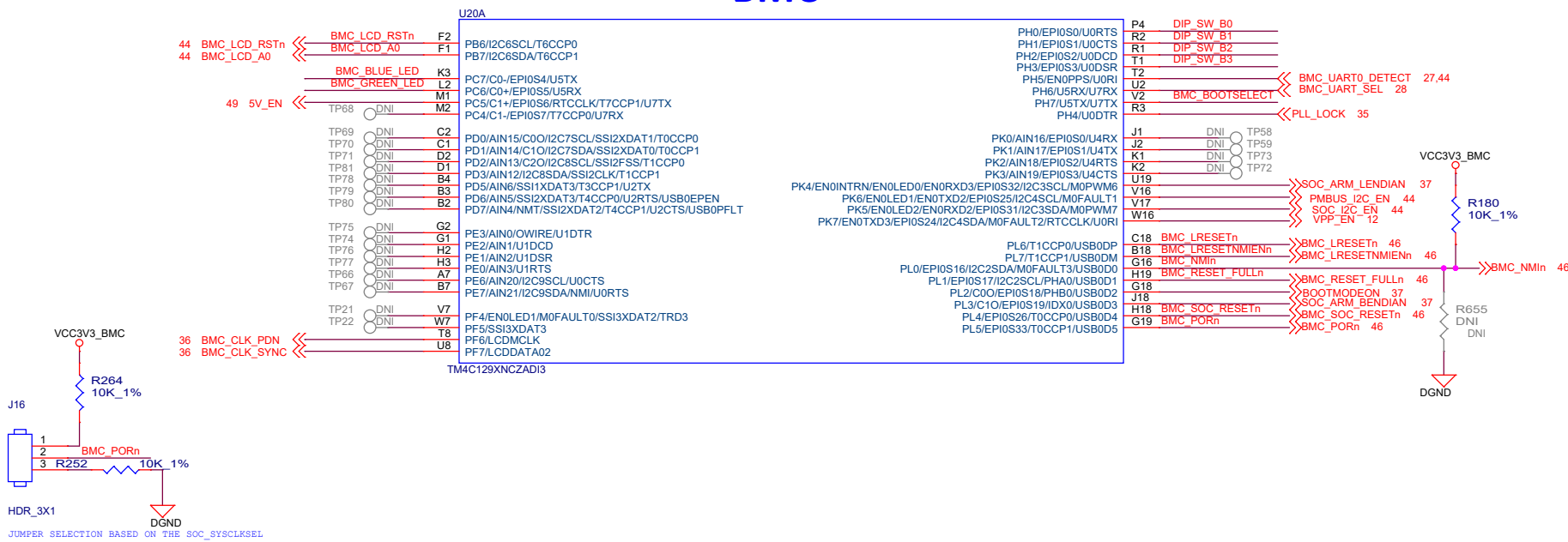

BMC CLOCK

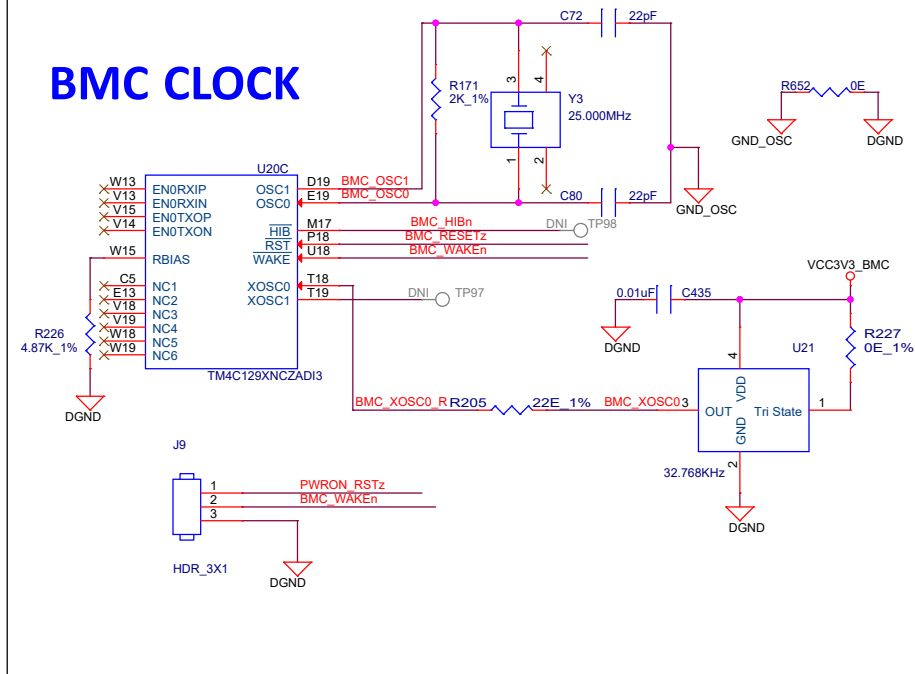

DIP SWITCH

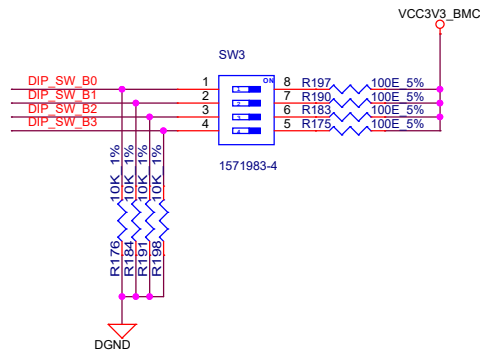

BMC BOOT SELECT

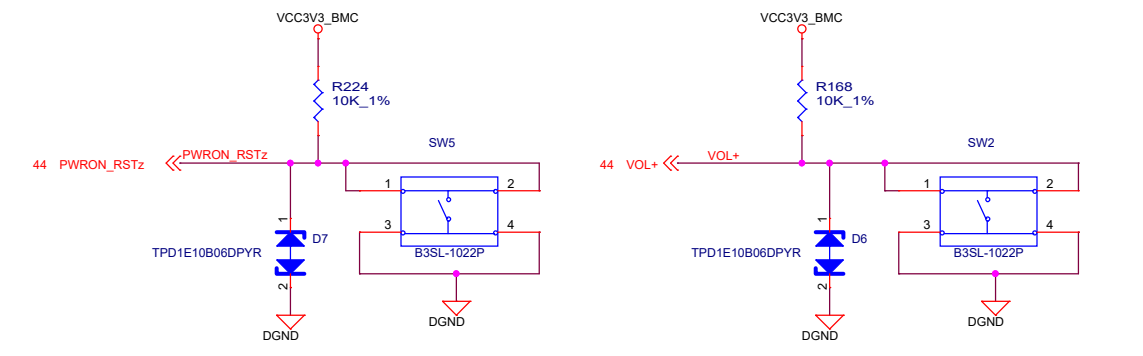
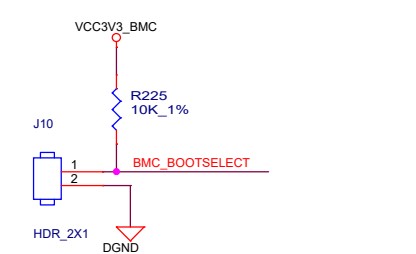

PUSH BUTTON SWITCHES

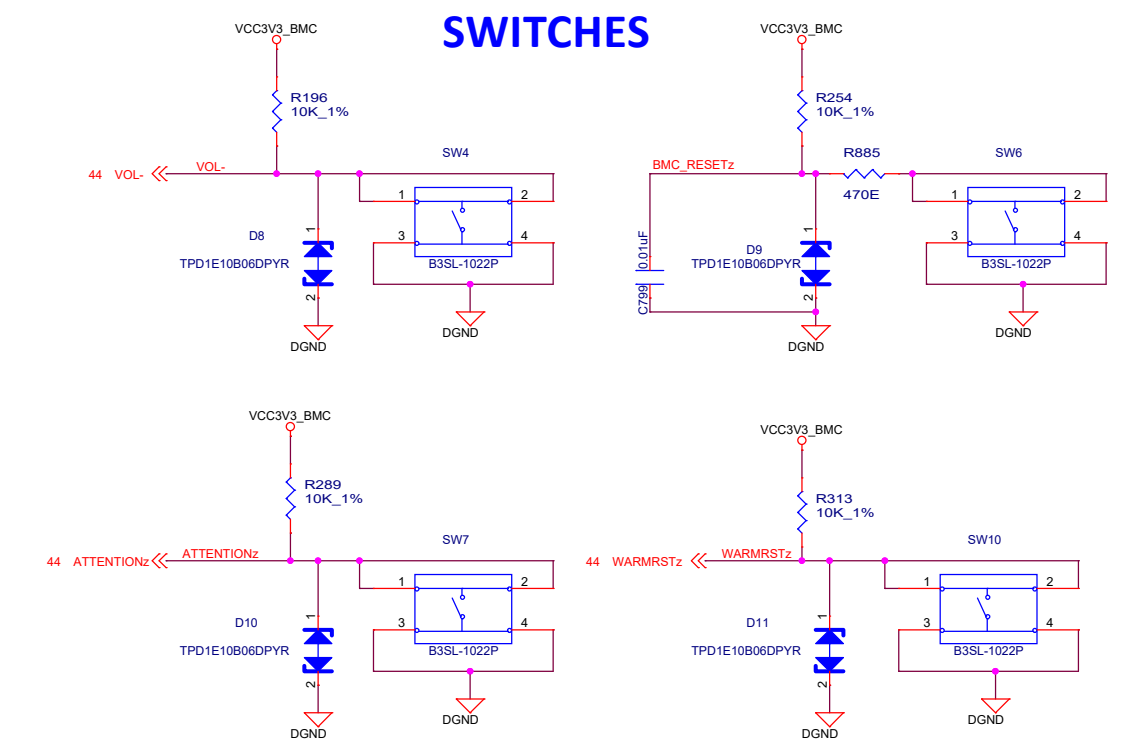

LEDS

LED BLUE

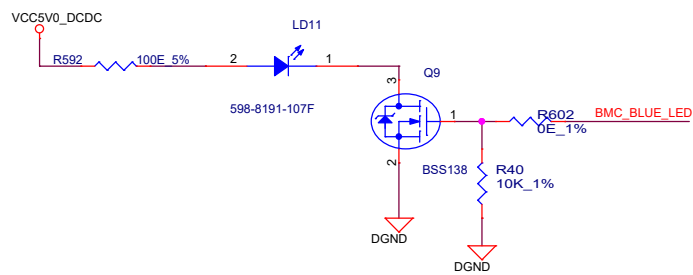

LED GREEN

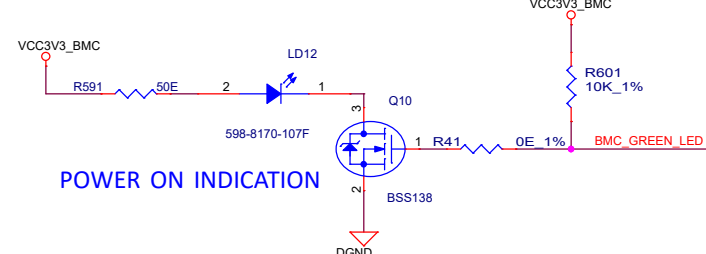

POWER ON INDICATION

LED BLUE

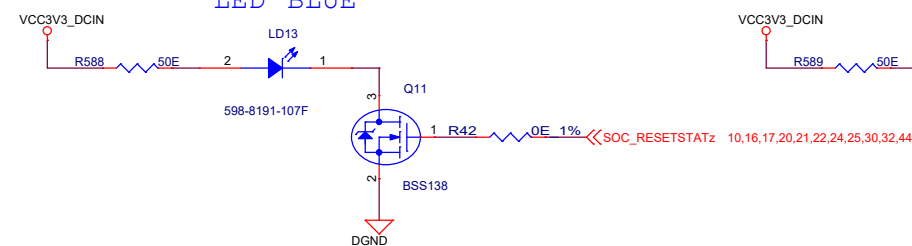

LED GREEN

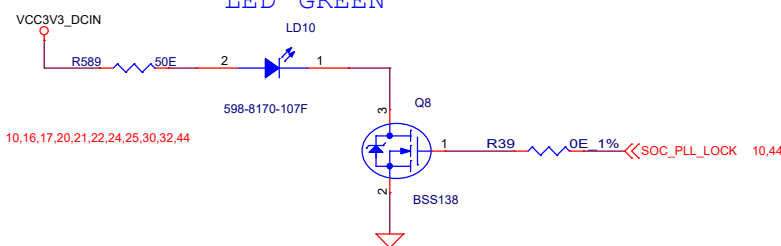

Designed for T1 by Mistral Solutions Pvt Ltd



Title		BOARD MANAGEMENT CONTROL_2	
Size	Variant Name = Proj PROC046 002 OPN# EVMK2GX5	Rev	A
Date:	Friday, February 02, 2018	Sheet	45 of 51

BMC 3.3V GENERATOR

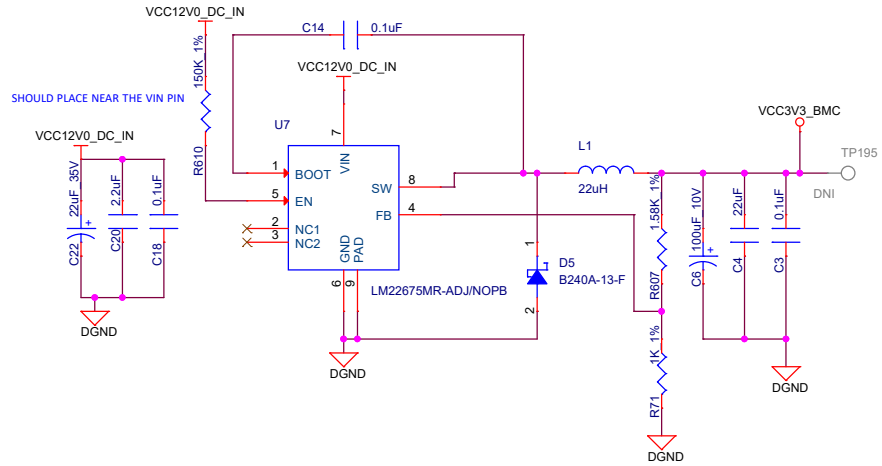

BMC LCD 3V GENERATOR

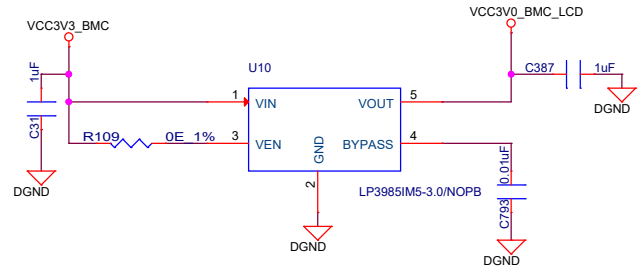

BMC POWER

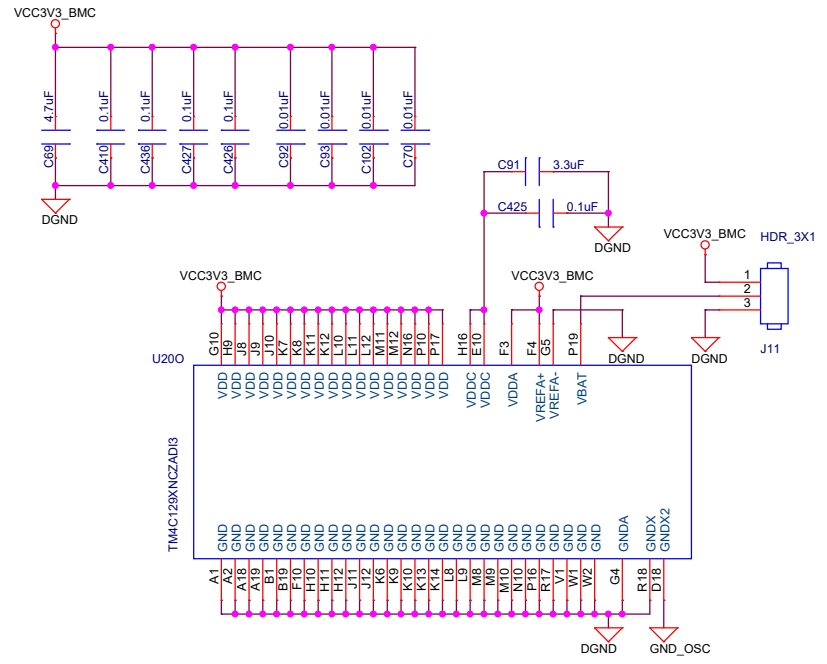

BMC ISOLATOR1

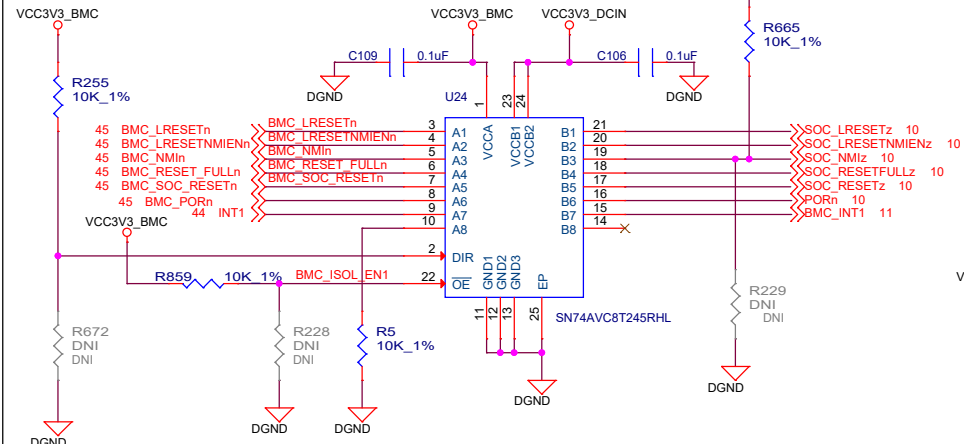

BMC ISOLATOR2

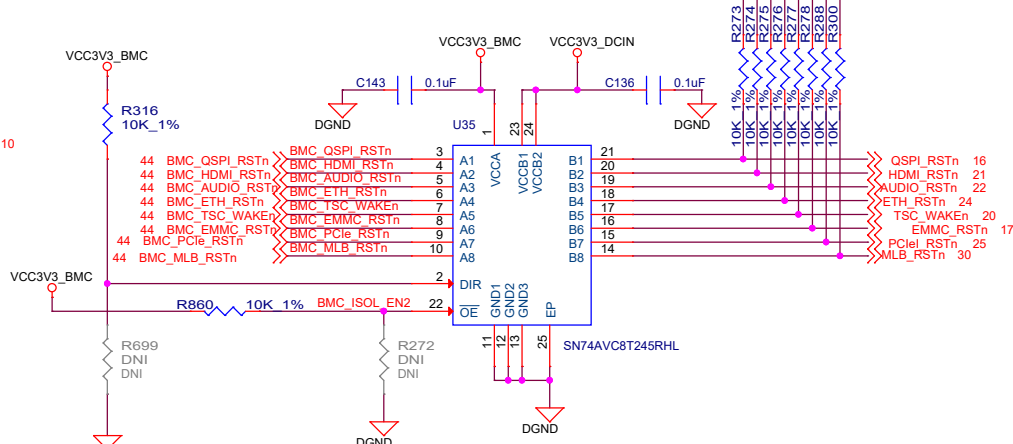

BMC ISOLATOR3

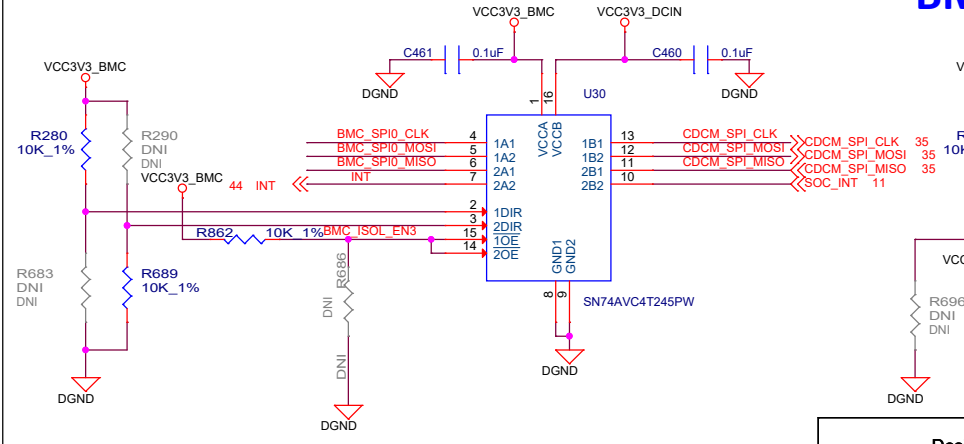

BMC ISOLATOR4

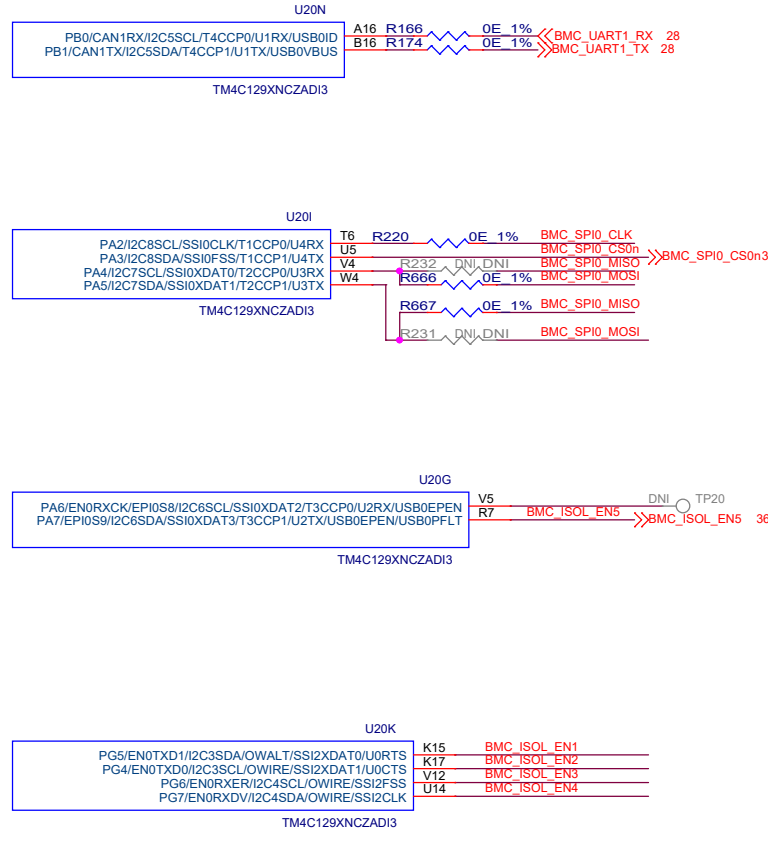
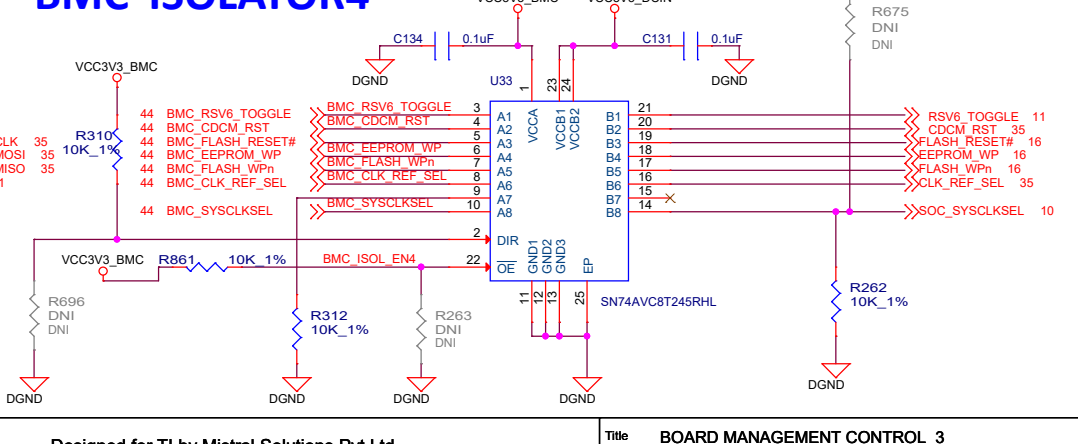

Designed for T1 by Mistral Solutions Pvt Ltd



Title BOARD MANAGEMENT CONTROL_3		
Size	Variant Name = Proj PROC046 002 OUP# EVMK2GX5	Rev
C		A
Date: Friday, February 02, 2018	Sheet 46 of 51	

PMIC POWER SECTION 1

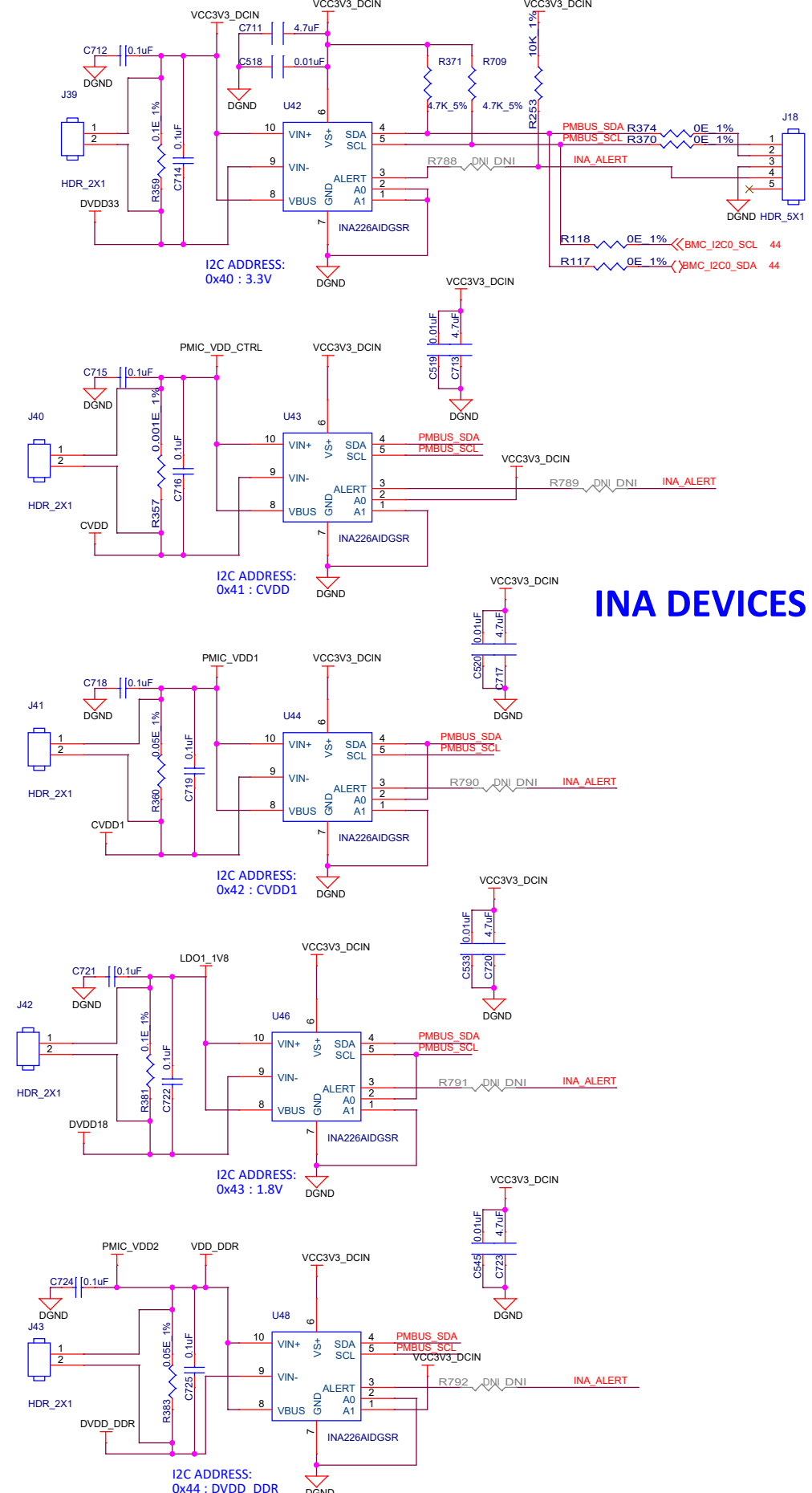
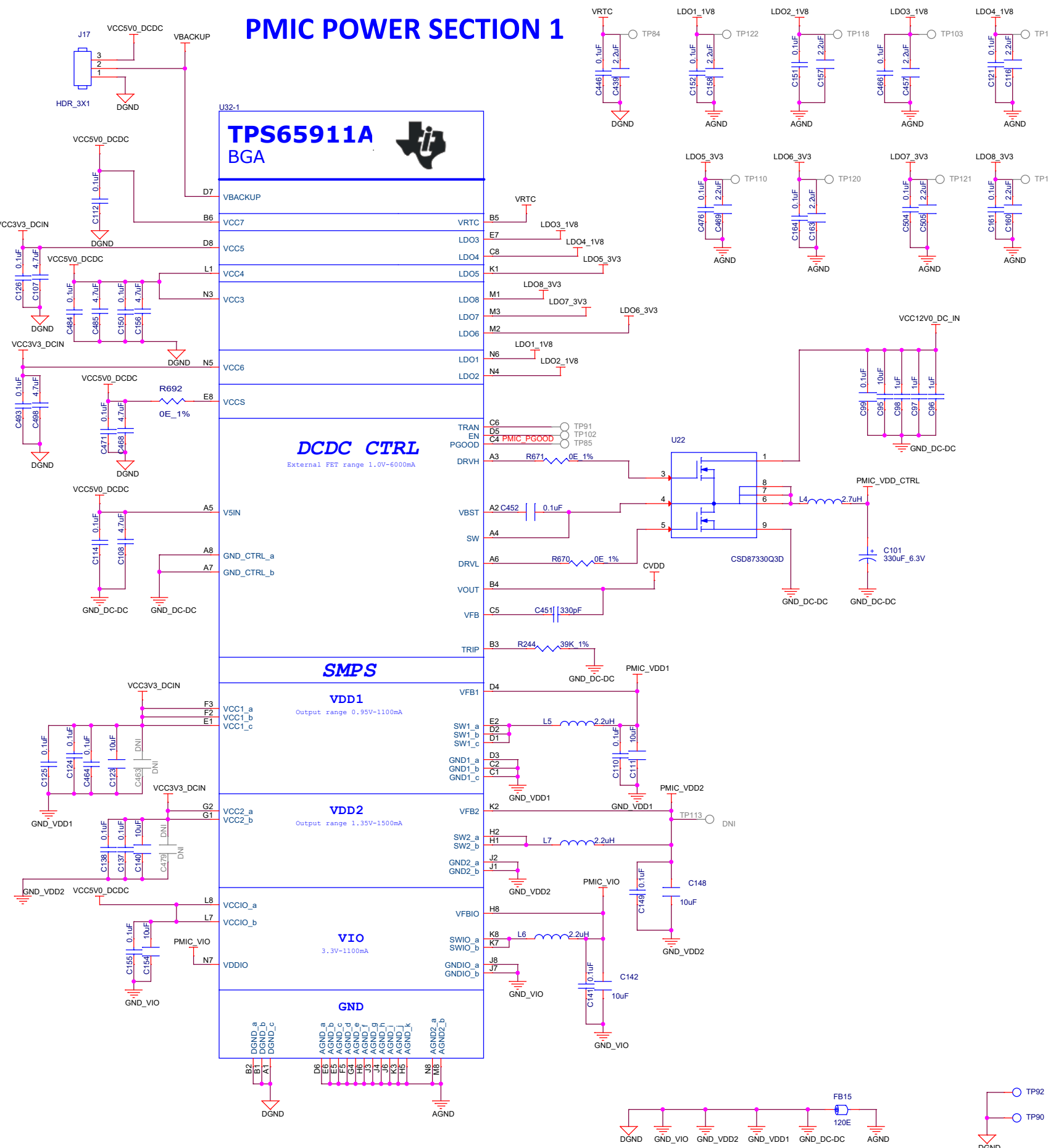
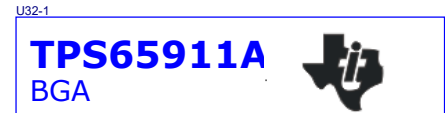

INA DEVICES

Designed for T1 by Mistral Solutions Pvt Ltd



Title **PMIC POWER CIRCUIT 1**

Size	Variant Name = Proj PROC046 002 OUP# EVMK2GX5	Rev	A
Date:	Friday, February 02, 2018	Sheet	47 of 51

PMIC POWER SECTION 2

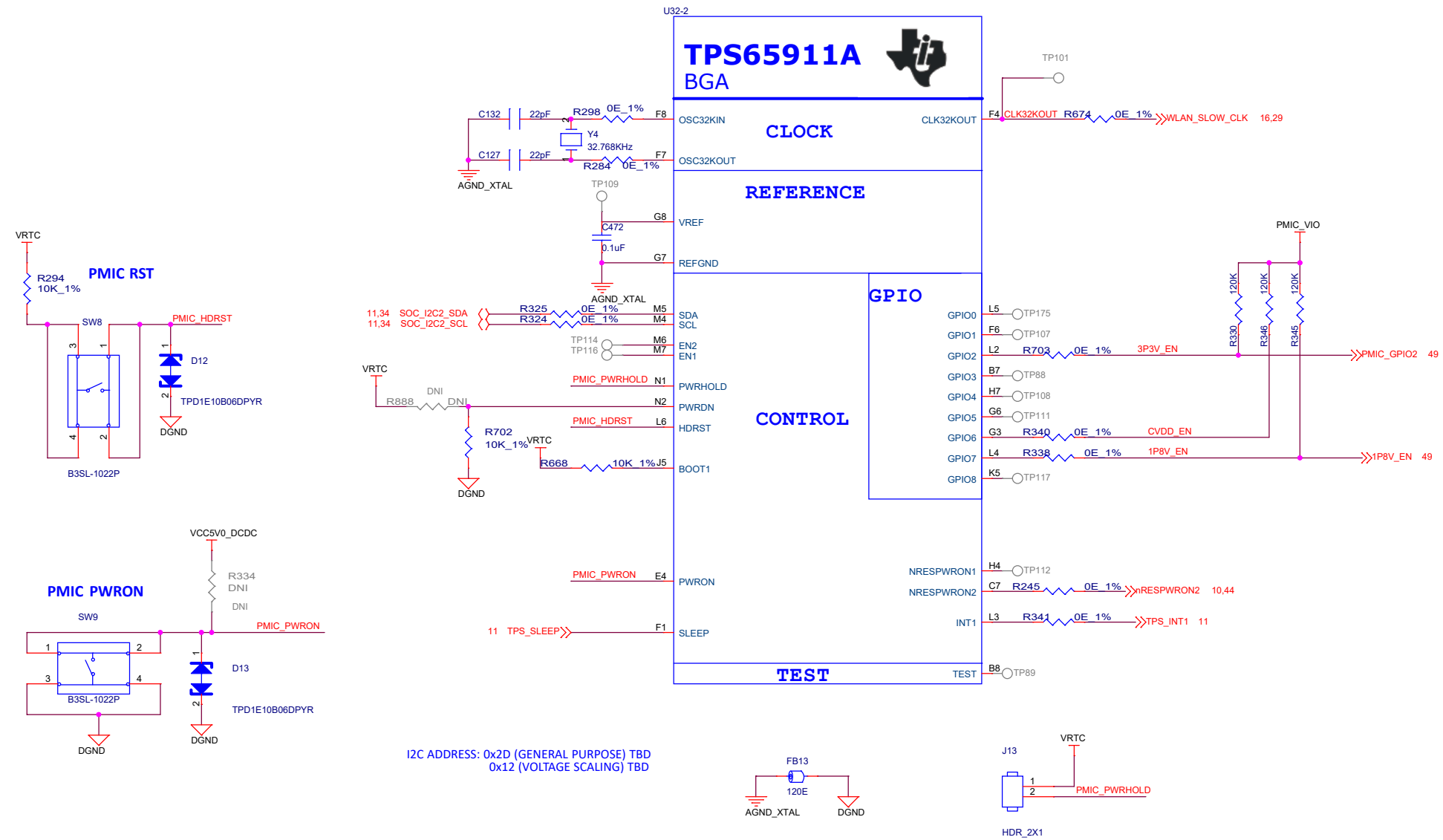

Designed for T1 by Mistral Solutions Pvt Ltd



Title: PMIC POWER CIRCUIT 2

Size	Variant Name = Proj PROC046 002 OPN# EVMK2GXS	Rev
C		A
Date:	Friday, February 02, 2018	Sheet 48 of 51

3.3V DC

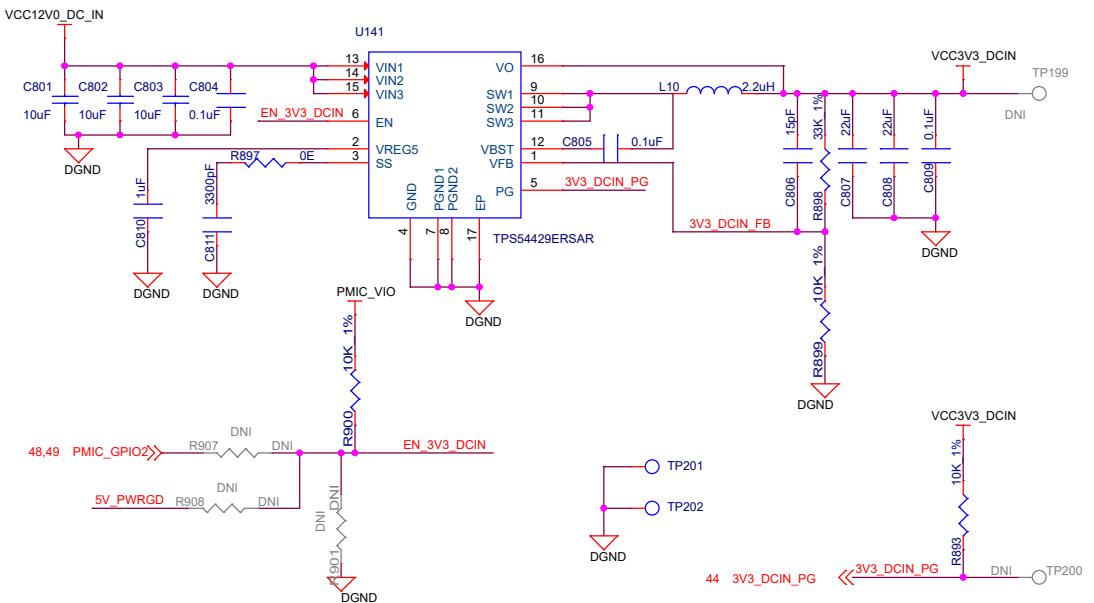

5V DC GENERATION

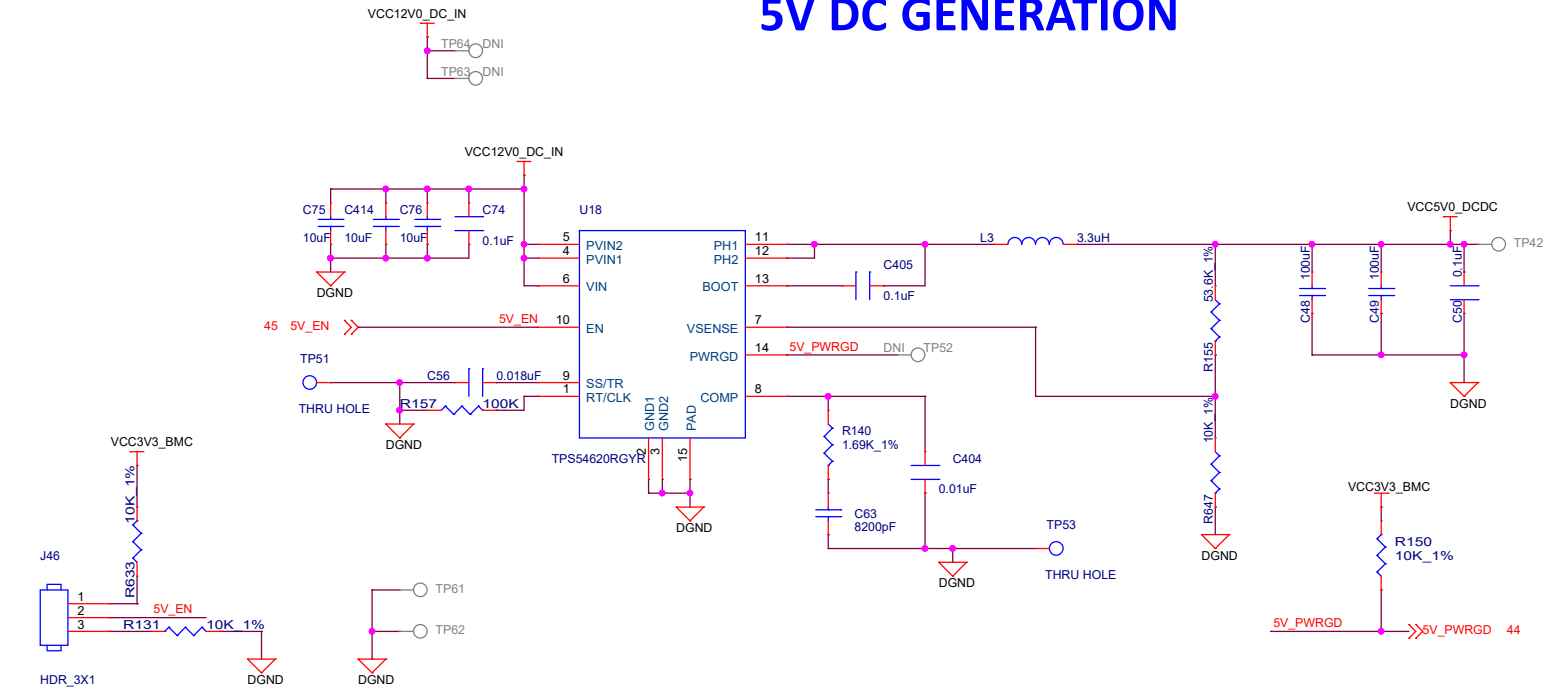

3.3V DC FOR CONNECTORS

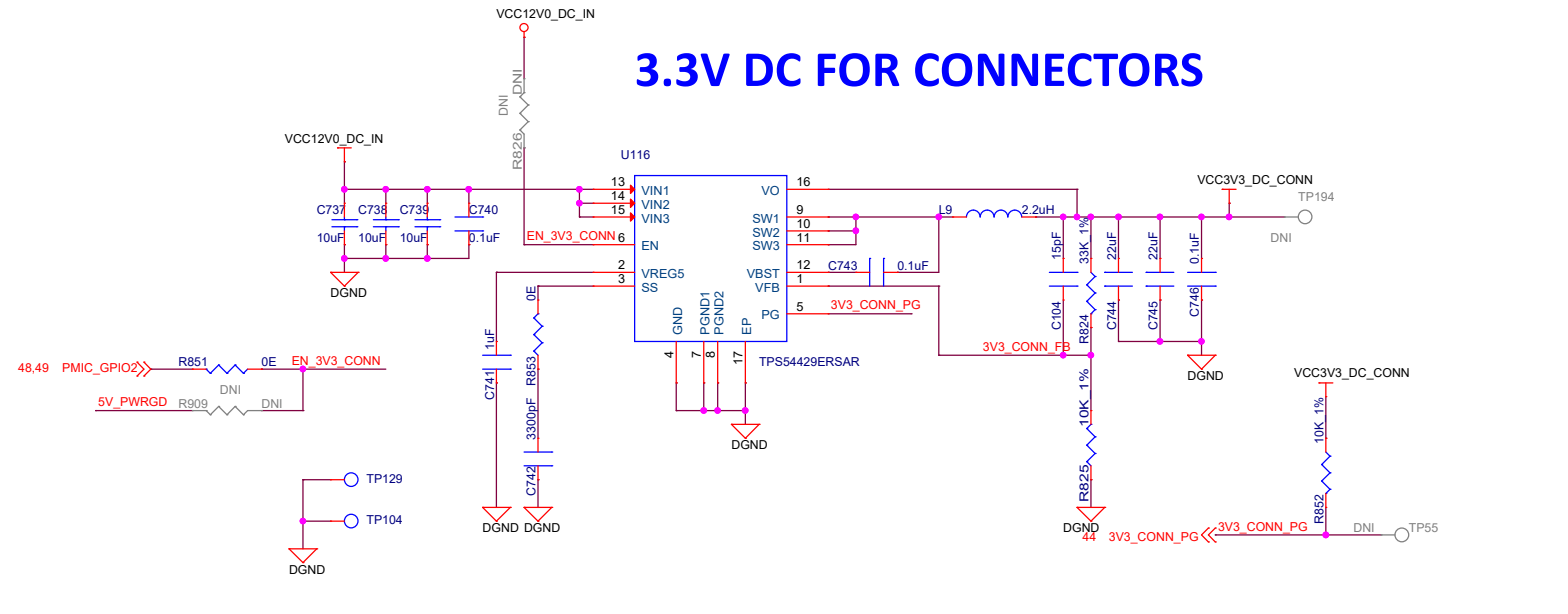

DDR VTT & VREF GENERATION

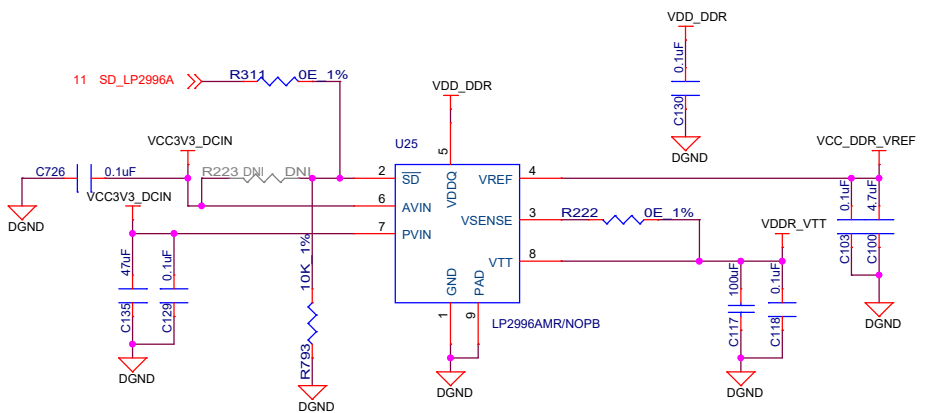

0.85V OPTIONAL LDO FOR PCIE & USB MODULES

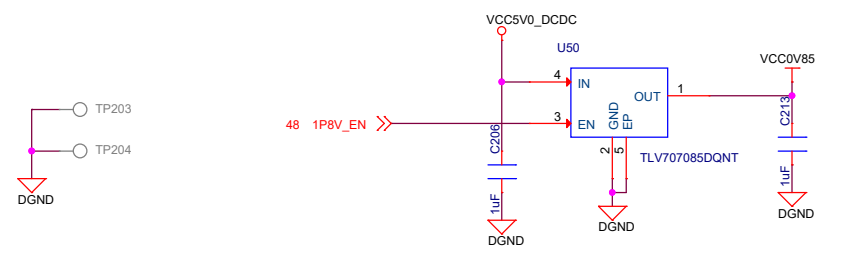

Designed for T1 by Mistral Solutions Pvt Ltd



Title		DDR3L POWER	
Size	Variant Name = Proj PROC046 002 EPN# EVMK2GXS	Rev	
C		A	
Date:	Friday, February 02, 2018	Sheet	49 of 51

OVER VOLTAGE PROTECTION CIRCUIT

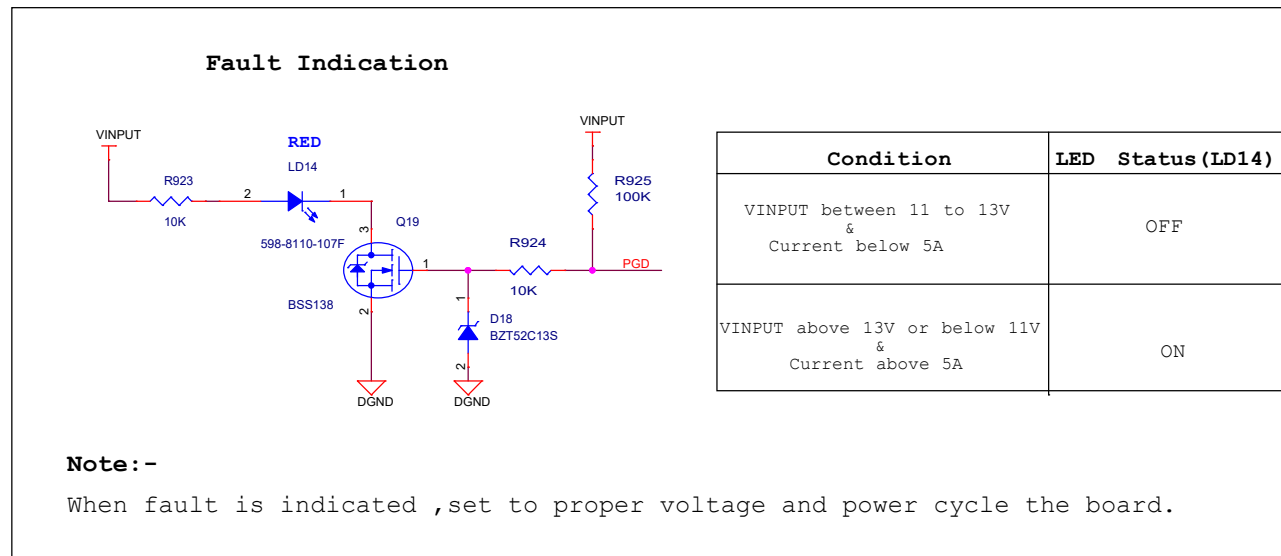
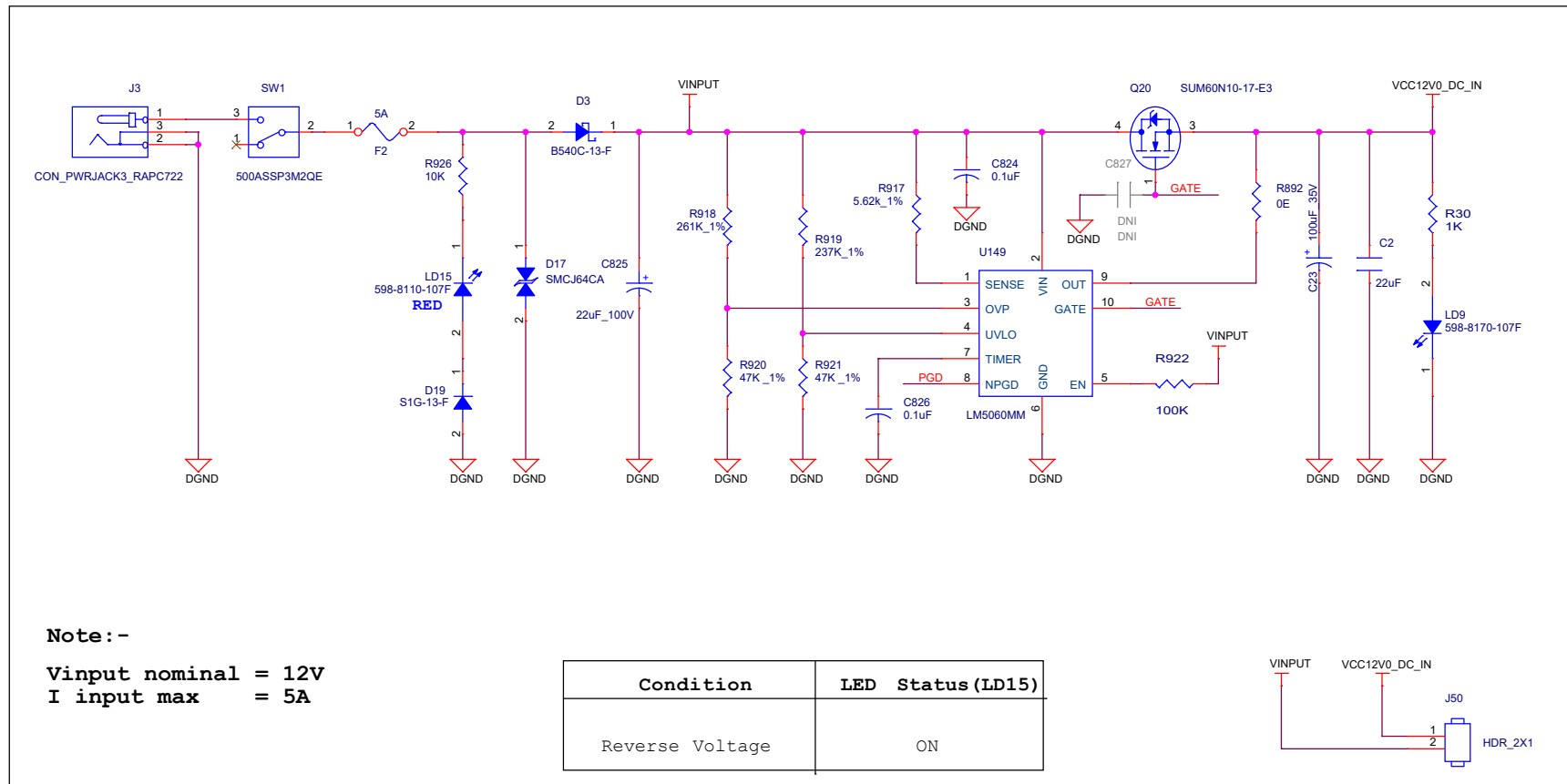

Designed for TI by Mistral Solutions Pvt Ltd



Title OVER VOLTAGE PROTECTION

Size	Variant Name = Proj PROC046 002 OPN# EVMK2GXS	Rev
C		A
Date:	Friday, February 02, 2018	Sheet 50 of 51

HARDWARE SCHEMATICS

FIDUCIALS



SCREWS AND NUTS



STANDOFFS

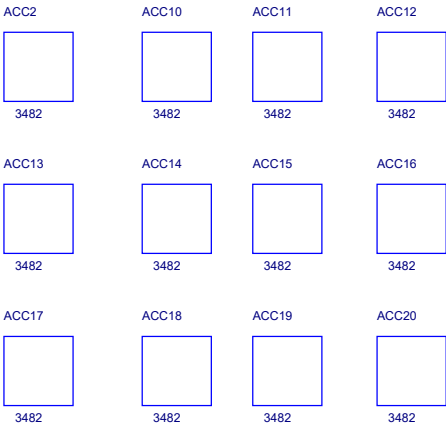

RUBBER FEET

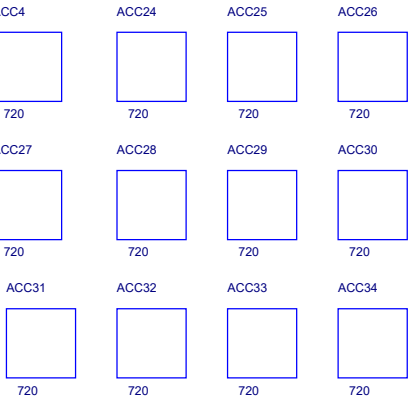

BARE PCB

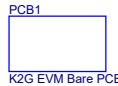

JUMPER

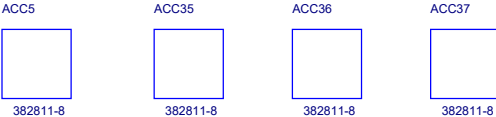

LABELS

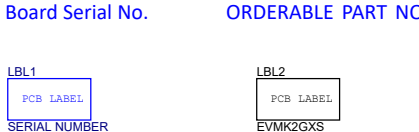

LOGOS



Socket & Processor as Accessories



Designed for TI by Mistral Solutions Pvt Ltd



Title		HARDWARE SCHEMATICS	
Size	Variant Name = Proj PROC046 002 OPN# EVMK2GXS	Rev	A
Date:	Friday, February 02, 2018	Sheet	51 of 51

IMPORTANT NOTICE FOR TI DESIGN INFORMATION AND RESOURCES

Texas Instruments Incorporated ("TI") technical, application or other design advice, services or information, including, but not limited to, reference designs and materials relating to evaluation modules, (collectively, "TI Resources") are intended to assist designers who are developing applications that incorporate TI products; by downloading, accessing or using any particular TI Resource in any way, you (individually or, if you are acting on behalf of a company, your company) agree to use it solely for this purpose and subject to the terms of this Notice.

TI's provision of TI Resources does not expand or otherwise alter TI's applicable published warranties or warranty disclaimers for TI products, and no additional obligations or liabilities arise from TI providing such TI Resources. TI reserves the right to make corrections, enhancements, improvements and other changes to its TI Resources.

You understand and agree that you remain responsible for using your independent analysis, evaluation and judgment in designing your applications and that you have full and exclusive responsibility to assure the safety of your applications and compliance of your applications (and of all TI products used in or for your applications) with all applicable regulations, laws and other applicable requirements. You represent that, with respect to your applications, you have all the necessary expertise to create and implement safeguards that (1) anticipate dangerous consequences of failures, (2) monitor failures and their consequences, and (3) lessen the likelihood of failures that might cause harm and take appropriate actions. You agree that prior to using or distributing any applications that include TI products, you will thoroughly test such applications and the functionality of such TI products as used in such applications. TI has not conducted any testing other than that specifically described in the published documentation for a particular TI Resource.

You are authorized to use, copy and modify any individual TI Resource only in connection with the development of applications that include the TI product(s) identified in such TI Resource. NO OTHER LICENSE, EXPRESS OR IMPLIED, BY ESTOPPEL OR OTHERWISE TO ANY OTHER TI INTELLECTUAL PROPERTY RIGHT, AND NO LICENSE TO ANY TECHNOLOGY OR INTELLECTUAL PROPERTY RIGHT OF TI OR ANY THIRD PARTY IS GRANTED HEREIN, including but not limited to any patent right, copyright, mask work right, or other intellectual property right relating to any combination, machine, or process in which TI products or services are used. Information regarding or referencing third-party products or services does not constitute a license to use such products or services, or a warranty or endorsement thereof. Use of TI Resources may require a license from a third party under the patents or other intellectual property of the third party, or a license from TI under the patents or other intellectual property of TI.

TI RESOURCES ARE PROVIDED "AS IS" AND WITH ALL FAULTS. TI DISCLAIMS ALL OTHER WARRANTIES OR REPRESENTATIONS, EXPRESS OR IMPLIED, REGARDING TI RESOURCES OR USE THEREOF, INCLUDING BUT NOT LIMITED TO ACCURACY OR COMPLETENESS, TITLE, ANY EPIDEMIC FAILURE WARRANTY AND ANY IMPLIED WARRANTIES OF MERCHANTABILITY, FITNESS FOR A PARTICULAR PURPOSE, AND NON-INFRINGEMENT OF ANY THIRD PARTY INTELLECTUAL PROPERTY RIGHTS.

TI SHALL NOT BE LIABLE FOR AND SHALL NOT DEFEND OR INDEMNIFY YOU AGAINST ANY CLAIM, INCLUDING BUT NOT LIMITED TO ANY INFRINGEMENT CLAIM THAT RELATES TO OR IS BASED ON ANY COMBINATION OF PRODUCTS EVEN IF DESCRIBED IN TI RESOURCES OR OTHERWISE. IN NO EVENT SHALL TI BE LIABLE FOR ANY ACTUAL, DIRECT, SPECIAL, COLLATERAL, INDIRECT, PUNITIVE, INCIDENTAL, CONSEQUENTIAL OR EXEMPLARY DAMAGES IN CONNECTION WITH OR ARISING OUT OF TI RESOURCES OR USE THEREOF, AND REGARDLESS OF WHETHER TI HAS BEEN ADVISED OF THE POSSIBILITY OF SUCH DAMAGES.

You agree to fully indemnify TI and its representatives against any damages, costs, losses, and/or liabilities arising out of your non-compliance with the terms and provisions of this Notice.

This Notice applies to TI Resources. Additional terms apply to the use and purchase of certain types of materials, TI products and services. These include; without limitation, TI's standard terms for semiconductor products (<http://www.ti.com/sc/docs/stdterms.htm>), [evaluation modules](#), and [samples](http://www.ti.com/sc/docs/sampterm.htm) (<http://www.ti.com/sc/docs/sampterm.htm>).

Mailing Address: Texas Instruments, Post Office Box 655303, Dallas, Texas 75265
Copyright © 2018, Texas Instruments Incorporated