

TMS320DM36x **Digital Media System-on-Chip (DMSoC)** **Asynchronous External Memory Interface** **(EMIF)**

User's Guide



Literature Number: SPRUF1C
March 2009–Revised April 2010

Preface	7
1 Introduction	10
1.1 Purpose of the Peripheral	10
1.2 Features	10
1.3 Functional Block Diagram	11
2 Peripheral Architecture	12
2.1 Clock Control	12
2.2 EMIF Requests	12
2.3 Signal Descriptions	12
2.4 Pin Multiplexing	13
2.5 Asynchronous Controller and Interface	13
2.6 Program Execution	33
2.7 Power Management	33
2.8 Emulation Considerations	33
3 Example Configuration	34
3.1 Interfacing to Asynchronous SRAM (ASRAM)	34
3.2 Interfacing to NAND Flash	44
4 Registers	53
4.1 Asynchronous Wait Cycle Configuration Register (AWCCR)	54
4.2 Asynchronous Configuration Registers (A1CR-A2CR)	55
4.3 EMIF Interrupt Raw Register (EIRR)	56
4.4 EMIF Interrupt Mask Register (EIMR)	57
4.5 EMIF Interrupt Mask Set Register (EIMSR)	58
4.6 EMIF Interrupt Mask Clear Register (EIMCR)	59
4.7 OneNAND Flash Control Register (ONENANDCTL)	60
4.8 NAND Flash Control Register (NANDFCR)	61
4.9 NAND Flash Status Register (NANDFSR)	62
4.10 NAND Flash <i>n</i> ECC Registers (NANDF1ECC-NANDF2ECC)	63
4.11 NAND Flash 4-bit ECC LOAD Register (NAND4BITECCLOAD)	65
4.12 NAND Flash 4-bit ECC Register 1 (NAND4BITECC1)	65
4.13 NAND Flash 4-bit ECC Register 2 (NAND4BITECC2)	66
4.14 NAND Flash 4-bit ECC Register 3 (NAND4BITECC3)	66
4.15 NAND Flash 4-bit ECC Register 4 (NAND4BITECC4)	67
4.16 NAND Flash 4-bit ECC Error Address Register 1 (NANDERRADD1)	67
4.17 NAND Flash 4-bit ECC Error Address Register 2 (NANDERRADD2)	68
4.18 NAND Flash 4-bit ECC Error Value Register 1 (NANDERRVAL1)	68
4.19 NAND Flash 4-bit ECC Error Value Register 2 (NANDERRVAL2)	68
5 Revision History	70

List of Figures

1	EMIF Functional Block Diagram	11
2	EMIF Asynchronous Interface	14
3	EMIF to 8-bit and 16-bit Memory Interfaces	14
4	Timing Waveform of an Asynchronous Read Cycle in Normal Mode	18
5	Timing Waveform of an Asynchronous Write Cycle in Normal Mode	20
6	Timing Waveform of an Asynchronous Read Cycle in Select Strobe Mode.....	22
7	Timing Waveform of an Asynchronous Write Cycle in Select Strobe Mode.....	23
8	EMIF to NAND Flash Interface	25
9	ECC Value for 8-Bit NAND Flash	27
10	Connecting to a 16-Bit OneNAND Flash in Asynchronous Read Mode.....	30
11	Connecting to a 16-Bit OneNAND Flash in Synchronous Read Mode	30
12	Timing Waveform of an Asynchronous Read Cycle in Normal Mode with Extended Wait	31
13	Timing Waveform of an Asynchronous Write Cycle in Normal Mode with Extended Wait	32
14	Connecting the EMIF to the TC55V16100FT-12	34
15	Timing Waveform of an ASRAM Read	36
16	Timing Waveform of an ASRAM Write	37
17	Timing Waveform of an ASRAM Read with PCB Delays	39
18	Timing Waveform of an ASRAM Write with PCB Delays	41
19	Timing Waveform of a NAND Flash Read	46
20	Timing Waveform of a NAND Flash Command Write	48
21	Timing Waveform of a NAND Flash Address Write	49
22	Timing Waveform of a NAND Flash Data Write	49
23	Asynchronous Wait Cycle Configuration Register (AWCCR).....	54
24	Asynchronous <i>n</i> Configuration Register (<i>An</i> CR)	55
25	EMIF Interrupt Raw Register (EIRR).....	56
26	EMIF Interrupt Mask Register (EIMR)	57
27	EMIF Interrupt Mask Set Register (EIMSR).....	58
28	EMIF Interrupt Mask Clear Register (EIMCR)	59
29	OneNAND Flash Control Register (ONENANDCTL)	60
30	NAND Flash Control Register (NANDFCR)	61
31	NAND Flash Status Register (NANDFSR)	62
32	NAND Flash <i>n</i> ECC Register (NANDFnECC)	63
33	NAND Flash 4-bit ECC LOAD Register (NAND4BITECCLOAD)	65
34	NAND Flash 4-bit ECC1 Register (NAND4BITECC1)	65
35	NAND Flash 4-bit ECC2 Register (NAND4BITECC2)	66
36	NAND Flash 4-bit ECC3 Register (NAND4BITECC3)	66
37	NAND Flash 4-bit ECC Register 4 (NAND4BITECC4)	67
38	NAND Flash 4-bit ECC Error Address Register 1 (NANDERRADD1).....	67
39	NAND Flash 4-bit ECC Error Address Register 2 (NANDERRADD2).....	68
40	NAND Flash 4-bit ECC Error Value Register 1 (NANDERRVAL1)	68
41	NAND Flash 4-bit ECC Error Value Register 2 (NANDERRVAL2)	68

List of Tables

1	EMIF Pins	12
2	Behavior of $\overline{EM_CE}$ Signal Between Normal Mode and Select Strobe Mode.....	13
3	Description of the Asynchronous Configuration Register (A_nCR)	15
4	Description of the Asynchronous Wait Cycle Configuration Register (AWCCR).....	16
5	Description of the EMIF Interrupt Mask Set Register (EIMSR).....	16
6	Description of the EMIF Interrupt Mast Clear Register (EIMCR).....	16
7	Asynchronous Read Operation in Normal Mode	17
8	Asynchronous Write Operation in Normal Mode	19
9	Asynchronous Read Operation in Select Strobe Mode	21
10	Asynchronous Write Operation in Select Strobe Mode.....	23
11	Description of the NAND Flash Control Register (NANDFCR)	24
12	Configuration For NAND Flash	24
13	Interrupt Monitor and Control Bit Fields Register Name Bit Name Description	33
14	EMIF Input Timing Requirements	35
15	ASRAM Output Timing Characteristics	35
16	ASRAM Input Timing Requirement for a Read.....	35
17	ASRAM Input Timing Requirements for a Write	36
18	ASRAM Timing Requirements With PCB Delays	38
19	EMIF Timing Requirements for TC5516100FT-12 Example	41
20	ASRAM Timing Requirements for TC5516100FT-12 Example	42
21	Measured PCB Delays for TC5516100FT-12 Example	42
22	Configuring A2CR for TC5516100FT-12 Example.....	44
23	Recommended Margins	44
24	EMIF Read Timing Requirements.....	45
25	NAND Flash Read Timing Requirements	45
26	NAND Flash Write Timing Requirements	47
27	EMIF Timing Requirements for HY27UA081G1M Example	50
28	NAND Flash Timing Requirements for HY27UA081G1M Example	50
29	Configuring A1CR for HY27UA081G1M Example	52
30	Configuring NANDFCR for HY27UA081G1M Example	52
31	External Memory Interface (EMIF) Registers	53
32	Asynchronous Wait Cycle Configuration Register (AWCCR) Field Descriptions	54
33	Asynchronous n Configuration Register (A_nCR) Field Descriptions.....	55
34	EMIF Interrupt Raw Register (EIRR) Field Descriptions	56
35	EMIF Interrupt Mask Register (EIMR) Field Descriptions	57
36	EMIF Interrupt Mask Set Register (EIMSR) Field Descriptions	58
37	EMIF Interrupt Mask Clear Register (EIMCR) Field Descriptions.....	59
38	OneNAND Flash Control Register (ONENANDCTL) Field Descriptions	60
39	NAND Flash Control Register (NANDFCR) Field Descriptions	61
40	NAND Flash Status Register (NANDFSR) Field Descriptions.....	62
41	NAND Flash n ECC Register (NANDFnECC) Field Descriptions.....	64
42	NAND Flash 4-bit ECC LOAD Register (NAND4BITECCLOAD) Field Descriptions	65
43	NAND Flash 4-bit ECC Register 1 (NAND4BITECC1) Field Descriptions.....	65
44	NAND Flash 4-bit ECC2 Register (NAND4BITECC2) Field Descriptions.....	66
45	NAND Flash 4-bit ECC Register 3 (NAND4BITECC3) Field Descriptions.....	66
46	NAND Flash 4-bit ECC Register 4 (NAND4BITECC4) Field Descriptions.....	67
47	NAND Flash 4-bit ECC Error Address Register 1 (NANDERRADD1) Field Descriptions	67

48	NAND Flash 4-bit ECC Error Address Register 2 (NANDERRADD2) Field Descriptions	68
49	NAND Flash 4-bit ECC Error Value Register 1 (NANDERRVAL1) Field Descriptions	68
50	NAND Flash 4-bit ECC Error Value Register 2 (NANDERRVAL2) Field Descriptions	69
51	Document Revision History	70

Read This First

This document describes the asynchronous external memory interface (EMIF) in the TMS320DM36x Digital Media System-on-Chip (DMSoC).

Notational Conventions

This document uses the following conventions.

- Hexadecimal numbers are shown with the suffix h. For example, the following number is 40 hexadecimal (decimal 64): 40h.
- Registers in this document are shown in figures and described in tables.
 - Each register figure shows a rectangle divided into fields that represent the fields of the register. Each field is labeled with its bit name, its beginning and ending bit numbers above, and its read/write properties below. A legend explains the notation used for the properties.
 - Reserved bits in a register figure designate a bit that is used for future device expansion.

Related Documentation from Texas Instruments

The following documents describe the TMS320DM36x Digital Media System-on-Chip (DMSoC). Copies of these documents are available on the internet at www.ti.com.

[SPRUFG5](#) — TMS320DM365 Digital Media System-on-Chip (DMSoC) ARM Subsystem Reference Guide This document describes the ARM Subsystem in the TMS320DM36x Digital Media System-on-Chip (DMSoC). The ARM subsystem is designed to give the ARM926EJ-S (ARM9) master control of the device. In general, the ARM is responsible for configuration and control of the device; including the components of the ARM Subsystem, the peripherals, and the external memories.

[SPRUFG8](#) — TMS320DM36x Digital Media System-on-Chip (DMSoC) Video Processing Front End (VPFE) Users Guide This document describes the Video Processing Front End (VPFE) in the TMS320DM36x Digital Media System-on-Chip (DMSoC).

[SPRUFG9](#) — TMS320DM36x Digital Media System-on-Chip (DMSoC) Video Processing Back End (VPBE) Users Guide This document describes the Video Processing Back End (VPBE) in the TMS320DM36x Digital Media System-on-Chip (DMSoC).

[SPRUFH0](#) — TMS320DM36x Digital Media System-on-Chip (DMSoC) 64-bit Timer Users Guide This document describes the operation of the software-programmable 64-bit timers in the TMS320DM36x Digital Media System-on-Chip (DMSoC).

[SPRUFH1](#) — TMS320DM36x Digital Media System-on-Chip (DMSoC) Serial Peripheral Interface (SPI) Users Guide This document describes the serial peripheral interface (SPI) in the TMS320DM36x Digital Media System-on-Chip (DMSoC). The SPI is a high-speed synchronous serial input/output port that allows a serial bit stream of programmed length (1 to 16 bits) to be shifted into and out of the device at a programmed bit-transfer rate. The SPI is normally used for communication between the DMSoC and external peripherals. Typical applications include an interface to external I/O or peripheral expansion via devices such as shift registers, display drivers, SPI EPROMs and analog-to-digital converters.

[SPRUFH2](#) — TMS320DM36x Digital Media System-on-Chip (DMSoC) Universal Asynchronous Receiver/Transmitter (UART) Users Guide This document describes the universal asynchronous receiver/transmitter (UART) peripheral in the TMS320DM36x Digital Media System-on-Chip (DMSoC). The UART peripheral performs serial-to-parallel conversion on data received from a peripheral device, and parallel-to-serial conversion on data received from the CPU.

- [SPRUFH3](#) — TMS320DM36x Digital Media System-on-Chip (DMSoC) Inter-Integrated Circuit (I2C) Peripheral Users Guide** This document describes the inter-integrated circuit (I2C) peripheral in the TMS320DM36x Digital Media System-on-Chip (DMSoC). The I2C peripheral provides an interface between the DMSoC and other devices compliant with the I2C-bus specification and connected by way of an I2C-bus.
- [SPRUFH5](#) — TMS320DM36x Digital Media System-on-Chip (DMSoC) Multimedia Card (MMC)/Secure Digital (SD) Card Controller Users Guide** This document describes the multimedia card (MMC)/secure digital (SD) card controller in the TMS320DM36x Digital Media System-on-Chip (DMSoC).
- [SPRUFH6](#) — TMS320DM36x Digital Media System-on-Chip (DMSoC) Pulse-Width Modulator (PWM) Users Guide** This document describes the pulse-width modulator (PWM) peripheral in the TMS320DM36x Digital Media System-on-Chip (DMSoC).
- [SPRUFH7](#) — TMS320DM36x Digital Media System-on-Chip (DMSoC) Real-Time Out (RTO) Controller Users Guide** This document describes the Real Time Out (RTO) controller in the TMS320DM36x Digital Media System-on-Chip (DMSoC).
- [SPRUFH8](#) — TMS320DM36x Digital Media System-on-Chip (DMSoC) General-Purpose Input/Output (GPIO) Users Guide** This document describes the general-purpose input/output (GPIO) peripheral in the TMS320DM36x Digital Media System-on-Chip (DMSoC). The GPIO peripheral provides dedicated general-purpose pins that can be configured as either inputs or outputs.
- [SPRUFH9](#) — TMS320DM36x Digital Media System-on-Chip (DMSoC) Universal Serial Bus (USB) Controller Users Guide** This document describes the universal serial bus (USB) controller in the TMS320DM36x Digital Media System-on-Chip (DMSoC). The USB controller supports data throughput rates up to 480 Mbps. It provides a mechanism for data transfer between USB devices and also supports host negotiation.
- [SPRUF10](#) — TMS320DM36x Digital Media System-on-Chip (DMSoC) Enhanced Direct Memory Access (EDMA) Controller Users Guide** This document describes the operation of the enhanced direct memory access (EDMA3) controller in the TMS320DM36x Digital Media System-on-Chip (DMSoC). The EDMA controller's primary purpose is to service user-programmed data transfers between two memory-mapped slave endpoints on the DMSoC.
- [SPRUF11](#) — TMS320DM36x Digital Media System-on-Chip (DMSoC) Asynchronous External Memory Interface (EMIF) Users Guide** This document describes the asynchronous external memory interface (EMIF) in the TMS320DM36x Digital Media System-on-Chip (DMSoC). The EMIF supports a glueless interface to a variety of external devices.
- [SPRUF12](#) — TMS320DM36x Digital Media System-on-Chip (DMSoC) DDR2/Mobile DDR (DDR2/mDDR) Memory Controller Users Guide** This document describes the DDR2/mDDR memory controller in the TMS320DM36x Digital Media System-on-Chip (DMSoC). The DDR2/mDDR memory controller is used to interface with JESD79D-2A standard compliant DDR2 SDRAM and mobile DDR devices.
- [SPRUF13](#) — TMS320DM36x Digital Media System-on-Chip (DMSoC) Multibuffered Serial Port Interface (McBSP) User's Guide** This document describes the operation of the multibuffered serial host port interface in the TMS320DM36x Digital Media System-on-Chip (DMSoC). The primary audio modes that are supported by the McBSP are the AC97 and IIS modes. In addition to the primary audio modes, the McBSP supports general serial port receive and transmit operation.
- [SPRUF14](#) — TMS320DM36x Digital Media System-on-Chip (DMSoC) Universal Host Port Interface (UHPI) User's Guide** This document describes the operation of the universal host port interface in the TMS320DM36x Digital Media System-on-Chip (DMSoC).
- [SPRUF15](#) — TMS320DM36x Digital Media System-on-Chip (DMSoC) Ethernet Media Access Controller (EMAC) User's Guide** This document describes the operation of the ethernet media access controller interface in the TMS320DM36x Digital Media System-on-Chip (DMSoC).

- [SPRUF17](#)** — ***TMS320DM36x Digital Media System-on-Chip (DMSoC) Analog to Digital Converter (ADC) User's Guide*** This document describes the operation of the analog to digital conversion in the TMS320DM36x Digital Media System-on-Chip (DMSoC).
- [SPRUF18](#)** — ***TMS320DM36x Digital Media System-on-Chip (DMSoC) Key Scan User's Guide*** This document describes the key scan peripheral in the TMS320DM36x Digital Media System-on-Chip (DMSoC).
- [SPRUF19](#)** — ***TMS320DM36x Digital Media System-on-Chip (DMSoC) Voice Codec User's Guide*** This document describes the voice codec peripheral in the TMS320DM36x Digital Media System-on-Chip (DMSoC). This module can access ADC/DAC data with internal FIFO (Read FIFO/Write FIFO). The CPU communicates to the voice codec module using 32-bit-wide control registers accessible via the internal peripheral bus.
- [SPRUFJ0](#)** — ***TMS320DM36x Digital Media System-on-Chip (DMSoC) Power Management and Real-Time Clock Subsystem (PRTCSS) User's Guide*** This document provides a functional description of the Power Management and Real-Time Clock Subsystem (PRTCSS) in the TMS320DM36x Digital Media System-on-Chip (DMSoC) and PRTC interface (PRTCIF).
- [SPRUGG8](#)** — ***TMS320DM36x Digital Media System-on-Chip (DMSoC) Face Detection User's Guide*** This document describes the face detection capabilities for the TMS320DM36x Digital Media System-on-Chip (DMSoC).

Asynchronous External Memory Interface (EMIF)

1 Introduction

This document describes the operation of the external memory interface (EMIF) in the TMS320DM36x Digital Media System-on-Chip (DMSoC).

1.1 Purpose of the Peripheral

The purpose of this EMIF is to provide a means to connect to a variety of external devices including:

- Asynchronous devices including Flash and SRAM
- NAND Flash
- OneNAND flash

The most common use for the EMIF is to interface with both flash devices and SRAM devices. The *Example Configuration* section contains examples of operating the EMIF in this configuration.

1.2 Features

The EMIF supports the following interfaces:

- Programmable asynchronous EMIF for interfacing to SRAM, etc.
- NAND flash memories
- OneNAND flash memories

The EMIF supports the following features:

- SRAM on up to two asynchronous chip selects addressable up to 16 Mega Bytes with 16 bit and 8 Mega Bytes with 8 bit each
- Supports 8-bit or 16-bit data bus widths
- Programmable asynchronous cycle timings
- Supports extended wait mode
- Supports select strobe mode
- Data bus parking

The NAND features of the EMIF are as follows:

- NAND flash on up to two asynchronous chip selects
- 8- and 16-bit data bus widths
- Programmable cycle timings
- Performs 1-bit and 4-bit ECC calculation
- NAND Mode also supports SmartMedia/SSFDC (Solid State Floppy Disk Controller) and xD memory cards

The OneNAND features of the EMIF are as follows:

- OneNAND flash on up to two asynchronous chip selects
- Only 16-bit data bus widths
- Supports asynchronous writes and reads
- Supports synchronous reads with continuous linear burst mode (Does not support synchronous reads with wrap burst modes)
- Programmable cycle timings for each chip select in asynchronous mode

1.3 Functional Block Diagram

Figure 1 illustrates the connections between the EMIF and its internal requesters, along with the external EMIF pins. Section 2.2 contains a description of the entities internal to the device that can send requests to the EMIF, along with their prioritization. Section 2.3 describes the EMIF's external pins and summarizes their purpose when interfacing with SDRAM and asynchronous devices.

Figure 1. EMIF Functional Block Diagram

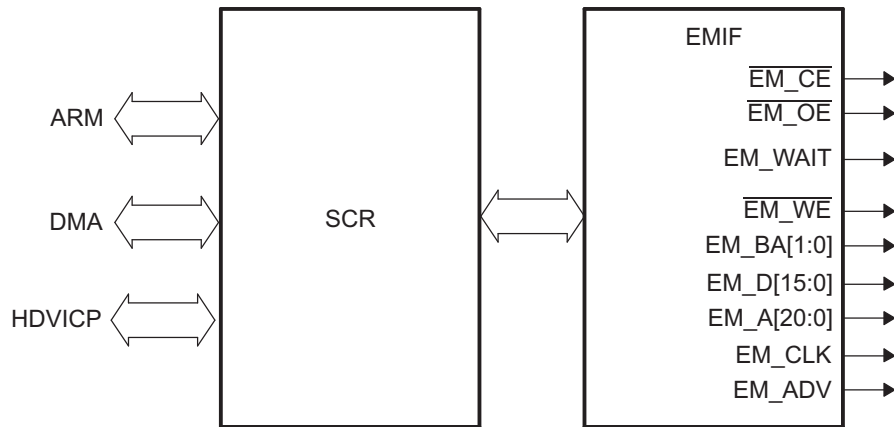

2 Peripheral Architecture

This section provides details about the architecture and operation of the EMIF.

2.1 Clock Control

The EMIF's internal clock is sourced from PLL controller 1. The EMIF's internal clock cannot be sourced directly from an external input clock. Changing the PLL controller 1 input reference clock and/or multiplier and divider parameters alters the operating frequency of the EMIF. For more information on how to program the PLL controller, see the *TMS320DM365 Digital Media System-on-Chip (DMSoC) ARM Subsystem Users Guide (SPRUG5)*.

2.2 EMIF Requests

Different sources within the device can make requests to the EMIF. These requests consist of accesses to asynchronous memory and EMIF memory mapped registers. Because the EMIF can process only one request at a time, a high performance switched central resource (SCR) exists to provide prioritized requests from the different sources to the EMIF. Each requester has a programmable priority value that may be configured in the System Control Module register MSTRPRIO or in the EDMA CC QUEPRI register. See the *TMS320DM365 Digital Media System-on-Chip (DMSoC) ARM Subsystem Users Guide (SPRUG5)* for more information on the System Control Module. See the *TMS320DM36x Digital Media system-on-Chip (DMSoC) Enhanced Direct Memory Access (EDMA) Controller User's Guide (SPRUFIO)* for more information on the EDMA. The sources are listed below from highest to lowest default priority value:

1. DMA
2. ARM
3. HDVICP

If a request is submitted from two or more sources simultaneously, the SCR will forward the highest priority request to the EMIF first. Upon completion of a request, the SCR again evaluates the pending requests and forwards the highest priority pending request to the EMIF.

2.3 Signal Descriptions

Table 1 describes the function of each of the EMIF pins.

Table 1. EMIF Pins

Pins(s)	I/O	Description
EM_A[20:0]	O	EMIF address bus. These pins are used in conjunction with the EM_BA pins to form the address that is sent to the device.
EM_BA[1:0]	O	EMIF bank address. These pins are used in conjunction with the EM_A pins to form the address that is sent to the device. Note that EM_A[0] does not represent the lowest AEMIF address bit. The EMIF supports only 16-bit and 8-bit data widths. In 16-bit mode, EM_BA[1] represents the least significant address bit (the half-word address) and EM_BA[0] represents the address bit (A[14]). In 8-bit mode, EM_BA[1:0] represent the 2 least significant address bits.
EM_CE[3:2] ⁽¹⁾	O	Active-low chip enable pin for asynchronous devices. These pins are meant to be connected to the chip-select pin of the attached asynchronous device.
EM_D[15:0]	I/O	EMIF data bus.
EM_OE	O	Active-low pin enable for asynchronous devices. This pin provides a signal which is active-low during the strobe period of an asynchronous read access cycle.
EM_WE	O	Active-low write enable. This pin provides a signal which is active-low during the strobe period of an asynchronous write access cycle.
EM_WAIT	I	Wait input with programmable polarity. A connected asynchronous device can extend the strobe period of an access cycle by asserting the WAIT input to the EMIF as described in Section 2.5.8 . To enable this functionality, the EW bit in the asynchronous configuration register (AnCR) must be set to 1. In addition, the WP0 bit in AnCR must be configured to define the polarity of the EM_WAIT pin.

⁽¹⁾ The device has two chip select pins. Throughout this document the chip select pins are named EM_CE[3:2], however, in the device-specific data manual and all other device documents these pins are named EM_CE[1:0].

Table 1. EMIF Pins (continued)

Pins(s)	I/O	Description
EM_CLK ⁽²⁾	O	OneNAND clock. This pin drives CLK input on connected OneNAND devices.
EM_ADV	O	OneNAND address valid. This pin drives ADV# input on connected OneNAND devices.

⁽²⁾ EM_CLK is always half of EMIF clock rate.

2.4 Pin Multiplexing

The EMIF pins are multiplexed with other peripherals. Please see the device-specific data manual for instructions on how to select the EMIF pins for proper operation.

2.5 Asynchronous Controller and Interface

The EMIF easily interfaces to a variety of asynchronous devices including Flash and ASRAM. It can be operated in three major modes :

- Normal mode
- Select Strobe (SS) mode
- NAND Flash mode
- OneNAND Flash mode

The behavior of the $\overline{\text{EM_CE}}$ signal is the single difference between Normal mode and Select Strobe mode (see [Table 2](#)). In Normal mode, the $\overline{\text{EM_CE}}$ signal becomes active at the beginning of the setup period and remains active for the duration of the transfer. In Select Strobe mode, the $\overline{\text{EM_CE}}$ signal functions as a strobe signal, active only during the strobe period of an access.

In NAND Flash mode, the EMIF hardware is able to calculate the error correction code (ECC) for each 512 byte data transfer. All NAND flash operations can be divided into single asynchronous cycles and can be performed using the EMIF's asynchronous interface. In OneNAND Flash mode, the EMIF supports 16-bit non-multiplexed OneNAND Flash on its asynchronous interface. All OneNAND Flash asynchronous operations can be divided into single asynchronous cycles, and can be performed using the EMIF's asynchronous interface. The EMIF also supports synchronous OneNAND Flash read operations. In addition to the four modes of operation, the EMIF also provides configurable cycle timing parameters and an Extended Wait mode that allows the connected device to extend the strobe period of an access cycle. The following sections describe the features related to interfacing with external asynchronous devices. Interfacing with OneNAND is described in [Section 2.5.8](#).

Table 2. Behavior of $\overline{\text{EM_CE}}$ Signal Between Normal Mode and Select Strobe Mode

Mode	Operation of $\overline{\text{EM_CE}}$ [3:2]
Normal	Active during the entire asynchronous access cycle
Select Strobe	Active only during the strobe period of an access cycle

2.5.1 Interfacing to Asynchronous Memory

[Figure 2](#) show the EMIF's external pins used in interfacing with an asynchronous device. Of special note is the connection between the EMIF and the external device's address bus. The EMIF address pin EM_A[0] always provides the least significant bit of a 32-bit address. Therefore, EM_A[0] does not represent the lowest AEMIF address bit. The EMIF supports only 16-bit and 8-bit data widths. In 16-bit mode, EM_BA[1] represents the least significant address bit (the half-word address) and EM_BA[0] represents the address bit (A[14]). In 8-bit mode, EM_BA[1:0] represent the 2 least significant address bits. [Figure 2](#) and [Figure 3](#) show the mapping between the EMIF and the connected device's data and address pins for various programmed data bus widths. The data bus width may be configured in the asynchronous configuration register (AnCR).

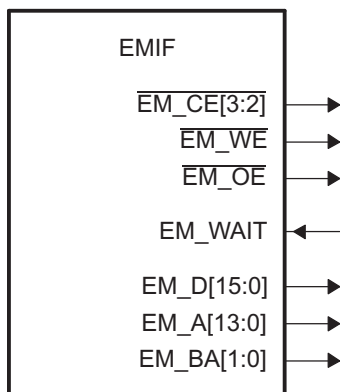
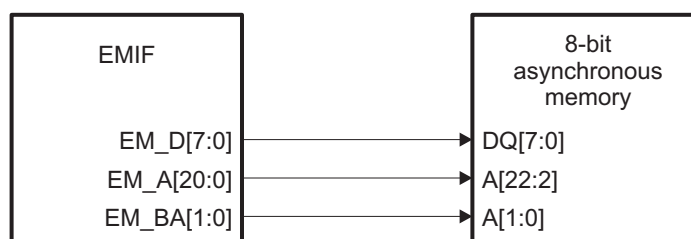
Figure 2. EMIF Asynchronous Interface

Figure 3. EMIF to 8-bit and 16-bit Memory Interfaces

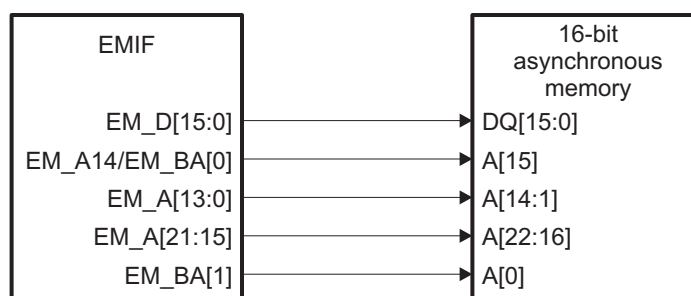
a) EMIF to 8-bit memory interface



b) EMIF to 16-bit memory interface

2.5.2 Programmable Asynchronous Parameters

The EMIF allows a high degree of programmability for shaping asynchronous accesses. The programmable parameters are:

- **Setup:** The time between the beginning of a memory cycle (address valid) and the activation of the output enable or write enable strobe
- **Strobe:** The time between the activation and deactivation of output enable or write enable strobe.
- **Hold:** The time between the deactivation of output enable or write enable strobe and the end of the cycle, which may be indicated by an address change or the deactivation of the $\overline{\text{EM_CE}}$ signal.

Separate parameters are provided for read and write cycles. Each parameter is programmed in terms of EMIF clock cycles.

2.5.3 Configuring the EMIF for Asynchronous Accesses

The operation of the EMIF's asynchronous interface can be configured by programming the appropriate memory-mapped registers. The reset value and bit position for each register field can be found in [Section 4](#). The following tables list the programmable register fields and describe the purpose of each field. These registers should not be programmed while an asynchronous access is in progress. The transfer following a write to these registers will use the new configuration.

[Table 3](#) describes the asynchronous configuration register ($A_n\text{CR}$). There are two $A_n\text{CR}$ s. Each chip select space has a dedicated $A_n\text{CR}$. This allows each chip select space to be programmed independently to interface to different asynchronous memory types.

Table 3. Description of the Asynchronous Configuration Register ($A_n\text{CR}$)

Parameter	Description
SS	<p>Select Strobe mode. This bit selects the EMIF's mode of operation in the following way:</p> <ul style="list-style-type: none"> • SS = 0h selects Normal mode. $\overline{\text{EM_CE}}$ is active for duration of access. • SS = 1h selects Select Strobe mode. $\overline{\text{EM_CE}}$ acts as a strobe.
EW	<p>Extended Wait mode enable.</p> <ul style="list-style-type: none"> • EW = 0h disables Extended Wait mode • EW = 1h enables Extended Wait mode <p>When set to 1, the EMIF enables its Extended Wait mode in which the strobe width of an access cycle can be extended in response to the assertion of the EM_WAIT pin. The WP0 bit in the asynchronous wait cycle configuration register (AWCCR) controls to polarity of EM_WAIT pin. See Section 2.5.8 for more details on this mode of operation.</p>
W_SETUP/R_SETUP	<p>Read/Write setup widths.</p> <p>These fields define the number of EMIF clock cycles of setup time for the address pins (EM_A and EM_BA) and asynchronous chip enable ($\overline{\text{EM_CE}}$) before the read strobe pin ($\overline{\text{EM_OE}}$) or write strobe pin ($\overline{\text{EM_WE}}$) falls, minus 1 cycle. For writes, the W_SETUP field also defines the setup time for the data pins (EM_D). Refer to the datasheet of the external asynchronous device to determine the appropriate setting for this field.</p>
W_STROBE/R_STROBE	<p>Read/Write strobe widths.</p> <p>These fields define the number of EMIF clock cycles between the falling and rising of the read strobe pin ($\overline{\text{EM_OE}}$) or write strobe pin ($\overline{\text{EM_WE}}$), minus 1 cycle. If Extended Wait mode is enabled by setting the EW bit in the asynchronous configuration register ($A_n\text{CR}$), these fields must be set to a value greater than zero. Refer to the datasheet of the external asynchronous device to determine the appropriate setting for this field.</p>
W_HOLD/R_HOLD	<p>Read/Write hold widths.</p> <p>These fields define the number of EMIF clock cycles of hold time for the address pins (EM_A and EM_BA) and asynchronous chip enable ($\overline{\text{EM_CE}}$) after the read strobe pin ($\overline{\text{EM_OE}}$) or write strobe pin ($\overline{\text{EM_WE}}$) rises, minus 1 cycle. For writes, the W_HOLD field also defines the hold time for the data pins (EM_D). Refer to the datasheet of the external asynchronous device to determine the appropriate setting for this field.</p>
TA	<p>Minimum turnaround time.</p> <p>This field defines the minimum number of EMIF clock cycles between the end of one asynchronous access and the start of another, minus 1 cycle. This delay is not incurred when a read is followed by a read, or a write is followed by a write to the same chip select space. The purpose of this feature is to avoid contention on the bus. Refer to the datasheet of the external asynchronous device to determine the appropriate setting for this field.</p>

Table 3. Description of the Asynchronous Configuration Register (A_nCR) (continued)

Parameter	Description
ASIZE	<p>Asynchronous Device Bus Width. This field determines the data bus width of the asynchronous interface in the following way:</p> <ul style="list-style-type: none"> ASIZE = 0h selects an 8-bit bus ASIZE = 1h selects a 16-bit bus <p>The configuration of ASIZE determines the function of the EM_A and EM_BA pins as described in Section 2.5.1. This field also determines the number of external accesses required to fulfill a request generated by one of the sources mentioned in Section 2.2. For example, a request for a 32-bit word would require four external access when ASIZE = 0h. Refer to the datasheet of the external asynchronous device to determine the appropriate setting for this field.</p>

Table 4. Description of the Asynchronous Wait Cycle Configuration Register (AWCCR)

Parameter	Description
WP0	<p>WAIT Polarity.</p> <ul style="list-style-type: none"> WP0 = 0h selects active-high polarity WP0 = 1h selects active-low polarity <p>When set to 1, the EMIF will wait if the EM_WAIT pin is high. When cleared to 0, the EMIF will wait if the EM_WAIT pin is low. The EMIF must have the Extended Wait mode enabled for the EM_WAIT pin to affect the width of the strobe period.</p>
MEWC	<p>Maximum Extended Wait Cycles. This field configures the number of EMIF clock cycles the EMIF will wait for the EM_WAIT pin to be deactivated during the strobe period of an access cycle. The maximum number of EMIF clock cycles the EMIF will wait is determined by the following formula:</p> $\text{Maximum Extended Wait Cycles} = (\text{MEWC} + 1) \times 16$ <p>If the EM_WAIT pin is not deactivated within the time specified by this field, the EMIF resumes the access cycle, registering whatever data is on the bus and preceding to the hold period of the access cycle. This situation is referred to as an asynchronous timeout. An asynchronous timeout generates an interrupt if it has been enabled in the EMIF interrupt mask set register (EIMSR). Refer to Section 2.5.11 for more information about the EMIF interrupts.</p>

Table 5. Description of the EMIF Interrupt Mask Set Register (EIMSR)

Parameter	Description
WRMSET	<p>Wait Rise Mask Set. Writing a 1 enables an interrupt to be generated when a rising edge on EM_WAIT occurs.</p>
ATMSET	<p>Asynchronous Timeout Mask Set. Writing a 1 to this bit enables an interrupt to be generated when an asynchronous timeout occurs.</p>

Table 6. Description of the EMIF Interrupt Mast Clear Register (EIMCR)

Parameter	Description
WRMCLR	<p>Wait Rise Mask Clear. Writing a 1 to this bit disables the interrupt, clearing the WRMSET bit in the EMIF interrupt mask set register (EIMSR).</p>
ATMCLR	<p>Asynchronous Timeout Mask Clear. Writing a 1 to this bit disables the interrupt, clearing the ATMSET bit in the EMIF interrupt mask set register (EIMSR).</p>

2.5.4 Read and Write Operations in Normal Mode

Normal mode is the asynchronous interface's default mode of operation. The Normal mode is selected when the SS bit in the asynchronous configuration register (*AnCR*) is cleared to 0. In this mode, the $\overline{\text{EM_CE}}$ signal operates as a chip enable signal, active throughout the duration of the memory access.

2.5.4.1 Asynchronous Read Operations (Normal Mode)

An asynchronous read is performed when any of the requesters mentioned in [Section 2.2](#) request a read from the attached asynchronous memory. In the event that the read request cannot be serviced by a single access cycle to the external device, multiple access cycles will be performed by the EMIF until the entire request is fulfilled. The details of an asynchronous read operation in Normal mode are described in [Table 7](#) and an example timing diagram of a basic read operation is shown in [Figure 4](#).

NOTE: During the entirety of an asynchronous read operation, the $\overline{\text{EM_WE}}$ pin is driven high.

Table 7. Asynchronous Read Operation in Normal Mode

Time Interval	Pin Activity in WE Strobe Mode
Turnaround period	Once the EMIF receives a read request, the EMIF waits for the programmed number of turn-around cycles before proceeding to the setup period of the operation. The number of wait cycles is taken directly from the TA field of the asynchronous configuration register (<i>AnCR</i>). There are two exceptions to this rule: <ul style="list-style-type: none"> • If the current read operation was directly preceded by another read operation to the same CS space, no turnaround cycles are inserted. • If the current read operation was not directly preceded by a read operation to the same CS space and the TA field has been cleared to 0, one turn-around cycle will be inserted. After the EMIF has waited for the turnaround cycles to complete, it proceeds to the setup period of the operation.
Start of setup period	At the beginning of the setup period: <ul style="list-style-type: none"> • The setup, strobe, and hold values are set according to the R_SETUP, R_STROBE, and R_HOLD values in <i>AnCR</i>. • The address pins EM_A and EM_BA become valid • $\overline{\text{EM_CE}}$ falls to enable the external device (if not already low from a previous operation)
Start of strobe period	At the beginning of the strobe period <ul style="list-style-type: none"> • $\overline{\text{EM_OE}}$ falls
Start of hold period	At the beginning of the hold period: <ul style="list-style-type: none"> • $\overline{\text{EM_OE}}$ rises • The EMIF samples the data on the EM_D bus.
End of hold period	At the end of the hold period: <ul style="list-style-type: none"> • The address pins EM_A and EM_BA become invalid • $\overline{\text{EM_CE}}$ rises (if no more operations are required to complete the current request) The EMIF will be required to issue additional read operations to a device with a small data bus width in order to complete an entire word access. In this case, the EMIF immediately re-enters the setup period to begin another operation without incurring the turn-round cycle delay. The setup, strobe, and hold values are not updated in this case. If the entire word access has been completed, the EMIF returns to its previous state unless another asynchronous request has been submitted and is currently the highest priority task. If this is the case, the EMIF instead enters directly into the turnaround period for the pending read or write operation.

Figure 4. Timing Waveform of an Asynchronous Read Cycle in Normal Mode

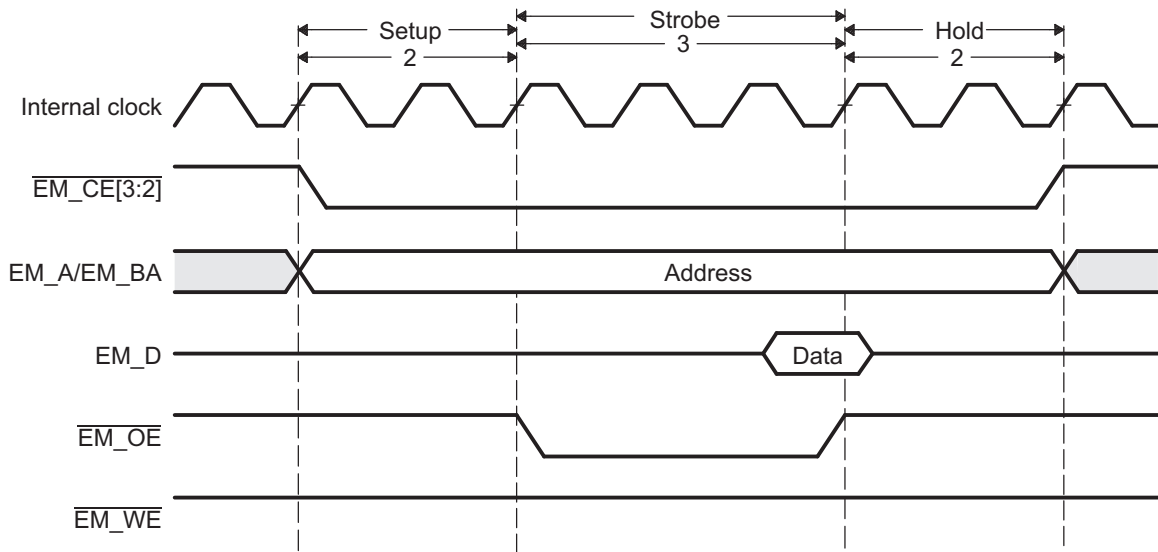

2.5.4.2 Asynchronous Write Operations (Normal Mode)

An asynchronous write is performed when any of the requesters mentioned in [Section 2.2](#) request a write to asynchronous memory. In the event that the write request cannot be serviced by a single access cycle to the external device, multiple access cycles will be performed by the EMIF until the entire request is fulfilled. The details of an asynchronous write operation in Normal mode are described in [Table 8](#) and an example timing diagram of a basic write operation is shown in [Figure 5](#).

NOTE: During the entirety of an asynchronous write operation, the $\overline{\text{EM_OE}}$ pin is driven high.

Table 8. Asynchronous Write Operation in Normal Mode

Time Interval	Pin Activity in WE Strobe Mode
Turnaround period	Once the EMIF receives a write request, the EMIF waits for the programmed number of turn-around cycles before proceeding to the setup period of the operation. The number of wait cycles is taken directly from the TA field of the asynchronous configuration register ($A_n\text{CR}$). There are two exceptions to this rule: <ul style="list-style-type: none"> If the current write operation was directly preceded by another write operation to the same CS space, no turnaround cycles are inserted. If the current write operation was not directly preceded by a write operation to the same CS space and the TA field has been cleared to 0, one turnaround cycle will be inserted. After the EMIF has waited for the turnaround cycles to complete, it proceeds to the setup period of the operation.
Start of setup period	At the beginning of the setup period: <ul style="list-style-type: none"> The setup, strobe, and hold values are set according to the W_SETUP, W_STROBE, and W_HOLD values in $A_n\text{CR}$. The address pins EM_A and EM_BA and the data pins EM_D become valid. $\overline{\text{EM_CE}}$ falls to enable the external device (if not already low from a previous operation).
Start of strobe period	At the beginning of the strobe period of a write operation: <ul style="list-style-type: none"> $\overline{\text{EM_WE}}$ falls
Start of hold period	At the beginning of the hold period <ul style="list-style-type: none"> $\overline{\text{EM_WE}}$ rises
End of hold period	At the end of the hold period: <ul style="list-style-type: none"> The address pins EM_A and EM_BA become invalid The data pins become invalid $\overline{\text{EM_CE}}$ rises (if no more operations are required to complete the current request) The EMIF may be required to issue additional write operations to a device with a small data bus width in order to complete an entire word access. In this case, the EMIF immediately re-enters the setup period to begin another operation without incurring the turnaround cycle delay. The setup, strobe, and hold values are not updated in this case. If the entire word access has been completed, the EMIF returns to its previous state unless another asynchronous request has been submitted. If this is the case, the EMIF instead enters directly into the turnaround period for the pending read or write operation.

Figure 5. Timing Waveform of an Asynchronous Write Cycle in Normal Mode

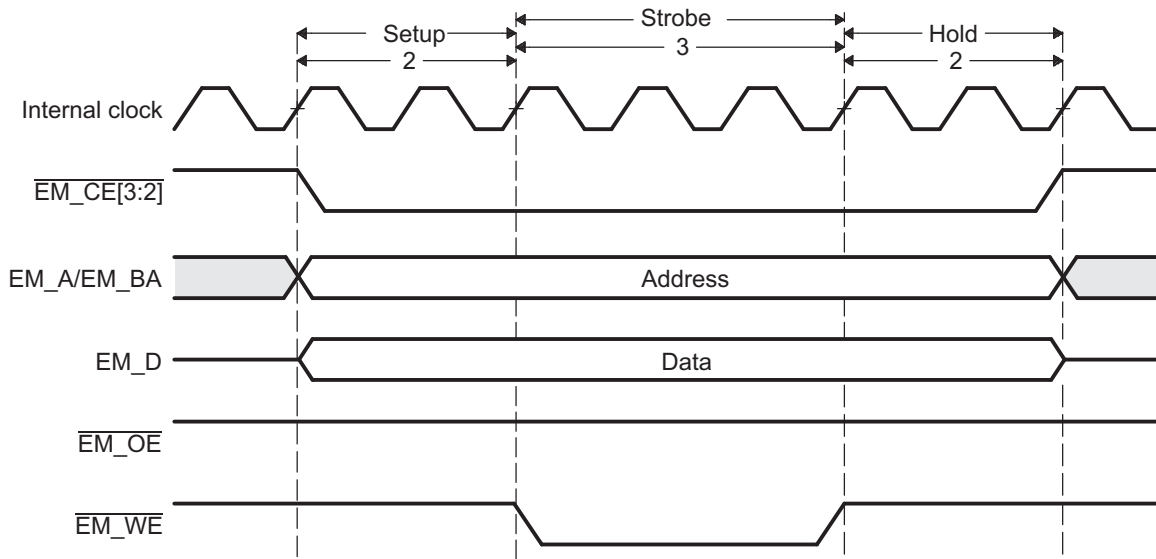

2.5.5 Read and Write Operations in Select Strobe Mode

Select Strobe mode is the EMIF's second mode of operation. The SS mode is selected when the SS bit in the asynchronous configuration register (A_nCR) is set to 1. In this mode, the $\overline{EM_CE}$ pin functions as a strobe signal and is therefore only active during the strobe period of an access cycle.

2.5.5.1 Asynchronous Read Operations (Select Strobe Mode)

An asynchronous read is performed when any of the requesters mentioned in [Section 2.2](#) request a read from the attached asynchronous memory. In the event that the read request cannot be serviced by a single access cycle to the external device, multiple access cycles will be performed by the EMIF until the entire request is fulfilled. The details of an asynchronous read operation in Select Strobe mode are described in [Table 9](#) and an example timing diagram of a basic read operation is shown in [Figure 6](#).

NOTE: During the entirety of an asynchronous read operation, the $\overline{EM_WE}$ pin is driven high.

Table 9. Asynchronous Read Operation in Select Strobe Mode

Time Interval	Pin Activity in Select Strobe Mode
Turnaround period	Once the EMIF receives a read request, the EMIF waits for the programmed number of turnaround cycles before proceeding to the setup period of the operation. The number of wait cycles is taken directly from the TA field of the asynchronous configuration register (A_nCR). There are two exceptions to this rule: <ul style="list-style-type: none"> • If the current read operation was directly preceded by another read operation to the same CS space, no turnaround cycles are inserted. • If the current read operation was not directly preceded by a read operation to the same CS space and the TA field has been cleared to 0, one turnaround cycle will be inserted. After the EMIF has waited for the turnaround cycles to complete, it proceeds to the setup period of the operation.
Start of setup period	At the beginning of the setup period: <ul style="list-style-type: none"> • The setup, strobe, and hold values are set according to the R_SETUP, R_STROBE, and R_HOLD values in A_nCR. • The address pins EM_A and EM_BA become valid.
Start of strobe period	At the beginning of the strobe period: <ul style="list-style-type: none"> • $\overline{EM_CE}$ and $\overline{EM_OE}$ fall at the start of the strobe period
Start of hold period	At the beginning of the hold period: <ul style="list-style-type: none"> • $\overline{EM_CE}$ and $\overline{EM_OE}$ rise • The EMIF samples the data on the EM_D bus
End of hold period	At the end of the hold period: <ul style="list-style-type: none"> • The address pins EM_A and EM_BA become invalid The EMIF may be required to issue additional read operations to a device with a small data bus width in order to complete an entire word access. In this case, the EMIF immediately re-enters the setup period to begin another operation without incurring the turnaround cycle delay. The setup, strobe, and hold values are not updated in this case. If the entire word access has been completed, the EMIF returns to its previous state unless another asynchronous request has been submitted. If this is the case, the EMIF instead enters directly into the turnaround period for the pending read or write operation.

Figure 6. Timing Waveform of an Asynchronous Read Cycle in Select Strobe Mode

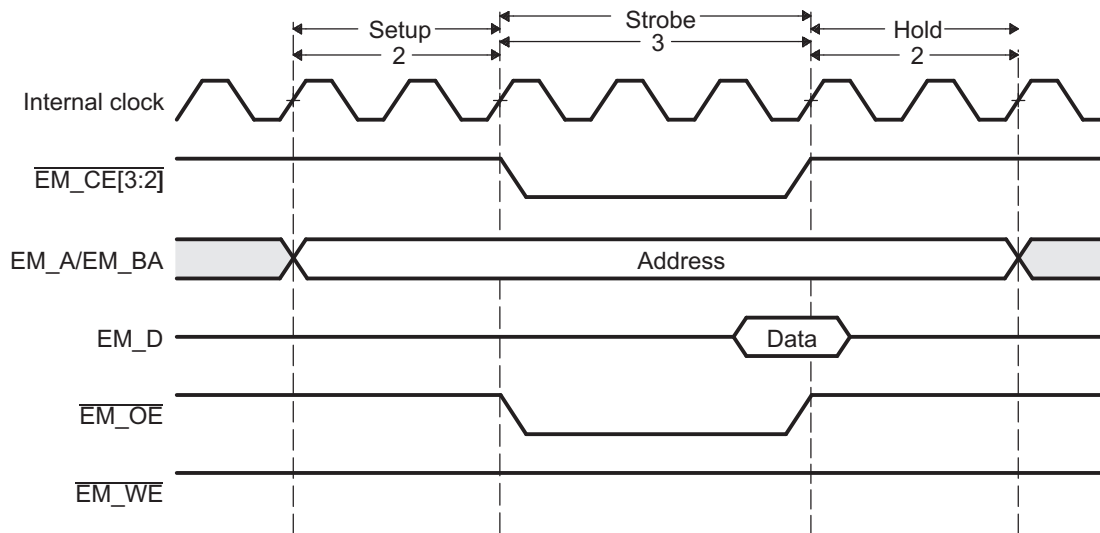

2.5.5.2 Asynchronous Write Operations (Select Strobe Mode)

An asynchronous write is performed when any of the requesters mentioned in Section 2.2 request a write to memory in the asynchronous bank of the EMIF. In the event that the write request cannot be serviced by a single access cycle to the external device, multiple access cycles will be performed by the EMIF until the entire request is fulfilled. The details of an asynchronous write operation in Select Strobe mode are described in Table 10 and an example timing diagram of a basic write operation is shown in Figure 7.

NOTE: During the entirety of an asynchronous write operation, the $\overline{\text{EM_OE}}$ pin is driven high.

Table 10. Asynchronous Write Operation in Select Strobe Mode

Time Interval	Pin Activity in Select Strobe Mode
Turnaround period	Once the EMIF receives a write request, the EMIF waits for the programmed number of turnaround cycles before proceeding to the setup period of the operation. The number of wait cycles is taken directly from the TA field of the asynchronous configuration register ($A_n\text{CR}$). There are two exceptions to this rule: <ul style="list-style-type: none"> If the current write operation was directly preceded by another write operation to the same CS space, no turnaround cycles are inserted. If the current write operation was directly preceded by a write operation to the same CS space and the TA field has been cleared to 0, one turnaround cycle will be inserted. After the EMIF has waited for the turnaround cycles to complete, it proceeds to the setup period of the operation.
Start of setup period	At the beginning of the setup period: <ul style="list-style-type: none"> The setup, strobe, and hold values are set according to the W_SETUP, W_STROBE, and W_HOLD values in $A_n\text{CR}$. The address pins EM_A and EM_BA and the data pins EM_D become valid.
Start of strobe period	At the beginning of the strobe period: <ul style="list-style-type: none"> $\overline{\text{EM_CE}}$ and $\overline{\text{EM_WE}}$ fall
Start of hold period	At the beginning of the hold period: <ul style="list-style-type: none"> $\overline{\text{EM_CE}}$ and $\overline{\text{EM_WE}}$ rise
End of hold period	At the end of the hold period: <ul style="list-style-type: none"> The address pins EM_A and EM_BA become invalid The data pins become invalid <p>The EMIF may be required to issue additional write operations to a device with a small data bus width in order to complete an entire word access. In this case, the EMIF immediately re-enters the setup period to begin another operation without incurring the turnaround cycle delay. The setup, strobe, and hold values are not updated in this case. If the entire word access has been completed, the EMIF returns to its previous state unless another asynchronous request has been submitted. If this is the case, the EMIF instead enters directly into the turn-around period for the pending read or write operation.</p>

Figure 7. Timing Waveform of an Asynchronous Write Cycle in Select Strobe Mode

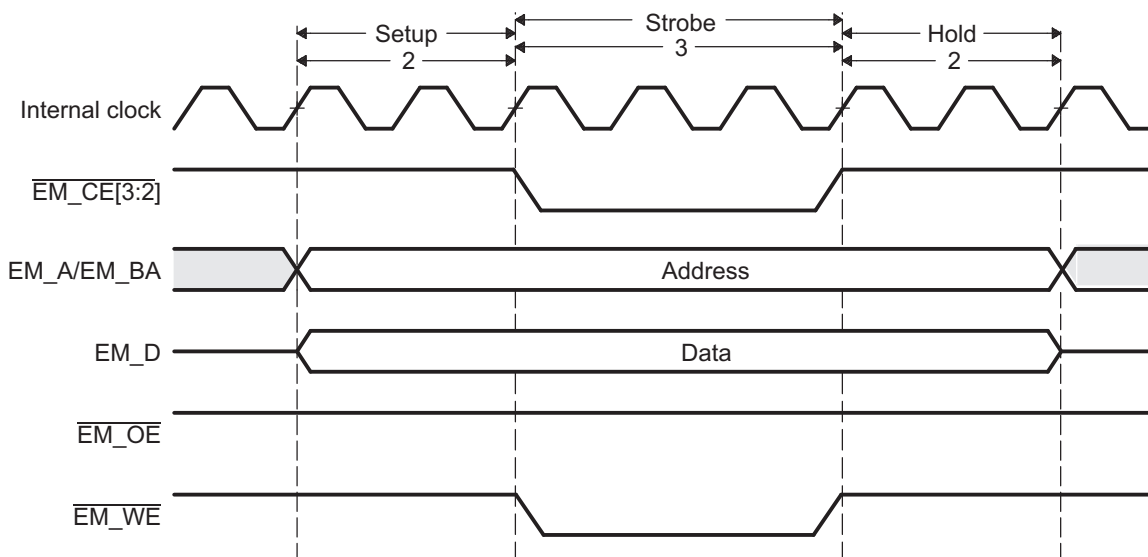

2.5.6 NAND Flash Mode

NAND Flash mode is the EMIF's third mode of operation. Each chip select space may be placed in NAND Flash mode individually by setting the appropriate CS n NAND bit in the NAND Flash control register (NANDFCR). [Table 11](#) displays the bit fields present in NANDFCR and briefly describes their use.

When a chip select space is configured to operate in NAND Flash mode, the EMIF hardware can calculate the error correction code (ECC) for each 512 byte data transfer to that chip select space. The EMIF hardware will not generate the NAND access cycle, which includes the command, address, and data phases, necessary to complete a transfer to NAND Flash. All NAND Flash operations can be divided into single asynchronous cycles and with the help of software, the EMIF can execute a complete NAND access cycle.

Table 11. Description of the NAND Flash Control Register (NANDFCR)

Parameter	Description
CS3ECC	NAND Flash ECC state for chip select 3. <ul style="list-style-type: none"> Set to 1 to start an ECC calculation. Cleared to 0 when NAND Flash 2 ECC register (NANDF1ECC) is read.
CS2ECC	NAND Flash ECC state for chip select 2. <ul style="list-style-type: none"> Set to 1 to start an ECC calculation. Cleared to 0 when NAND Flash 1 ECC register (NANDF1ECC) is read.
CS3NAND	NAND Flash mode for chip select 3. <ul style="list-style-type: none"> Set to 1 to enable NAND Flash mode.
CS2NAND	NAND Flash mode for chip select 2. <ul style="list-style-type: none"> Set to 1 to enable NAND Flash mode.

2.5.6.1 Configuring for NAND Flash Mode

Similar to the asynchronous accesses previously described, the EMIF's memory-mapped registers must be programmed appropriately to interface to a NAND Flash device. [Table 12](#) lists the bit fields that must be programmed when operating in NAND Flash mode and the values to set each bit. NAND Flash mode cannot be used with Extended Wait mode.

Table 12. Configuration For NAND Flash

Register	Bit Field	Configuration Value
Asynchronous configuration register (AnCR)	SS	0
	EW	0
	W_SETUP/R_SETUP	See Section 2.5.3 for information on how to program.
	W_STROBE/R_STROBE	See Section 2.5.3 for information on how to program.
	W_HOLD/R_HOLD	See Section 2.5.3 for information on how to program.
	ASIZE	Programmed to equal the width of the NAND Flash device
NAND Flash control register (NANDFCR)	CS n NAND	1

2.5.6.2 Connecting to NAND Flash

Figure 8 shows the EMIF external pins used to interface with a NAND Flash device. EMIF address lines are used to drive the NAND Flash device's command latch enable (CLE) and address latch enable (ALE) signals. Any EMIF address line may be used to drive the CLE and ALE signals of the NAND Flash. However, it is recommended, especially when booting from NAND Flash, that EM_A[2:1] be used. This is because these pins are not muxed with another peripheral and are therefore always available.

NOTE: The EMIF will not control the NAND Flash device's write protect pin. The write protect pin must be controlled outside of the EMIF.

Figure 8. EMIF to NAND Flash Interface

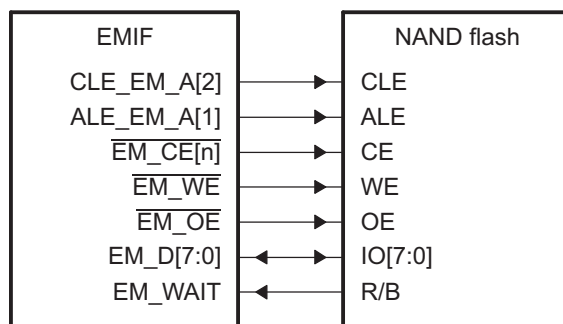

a) Connection to 8-bit NAND device

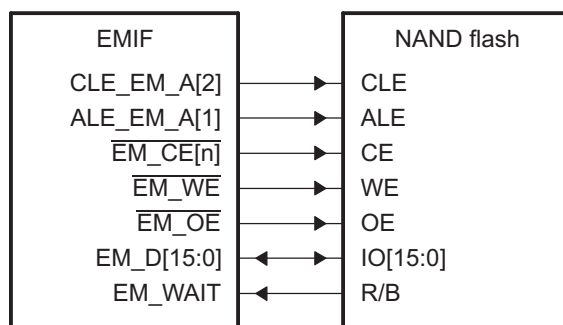

b) Connection to 16-bit NAND device

2.5.6.3 Driving CLE and ALE

As stated in [Section 2.5.1](#), the EMIF always drives the least significant bit of a 32-bit word address on EM_A[0]. This functionality must be considered when attempting to drive the address lines connected to CLE and ALE to the appropriate state.

For example, if using EM_A[2] and EM_A[1] to connect to CLE and ALE, respectively, the following offsets should be chosen:

- 00h to drive CLE and ALE low
- 10h to drive CLE high and ALE low
- 0Bh to drive CLE low and ALE high

These offsets should be added to the base address for the chip select space the NAND Flash device is connected to. For example, if the base address of the CS space the NAND Flash device is connected to is 0200 0000h, then the above lists translates to the following memory-mapped addresses: 0200 0000h, 0200 0010h, and 0200 000Bh, respectively. Therefore, when attempting to drive CLE high and ALE low, the memory-mapped address of 0200 0010h would be written to.

2.5.6.4 NAND Read and Program Operations

A NAND Flash access cycle is composed of a command, address, and data phase. The EMIF will not automatically generate these three phases to complete a NAND access with one transfer request. To complete a NAND access cycle, multiple single asynchronous access cycles (as described above) must be completed by the EMIF. Software must be used to request the appropriate asynchronous accesses to complete a NAND Flash access cycle. This software must be developed to the specification of the chosen NAND Flash device.

Since NAND operations are divided into single asynchronous access cycles, the chip select signal will not remain activated for the duration of the NAND operation. Instead, the chip select signal will deactivate between each asynchronous access cycle. For this reason, the EMIF does not support NAND Flash devices that require the chip select signal to remain low during the t_R time for a read. See [Section 2.5.6.8](#) for workaround.

Care must be taken when performing a NAND read or write operation via the EDMA. See [Section 2.5.6.5](#) for more details.

NOTE: The EMIF does not support NAND Flash devices that require the chip select signal to remain low during the t_R time for a read. See [Section 2.5.6.8](#) for workaround.

2.5.6.5 NAND Data Read and Write via DMA

When performing NAND accesses, the EDMA is most efficiently used for the data phase of the access. The command and address phases of the NAND access require only a few words of data to be transferred and therefore do not take advantage of the EDMA's ability to transfer larger quantities of data with a single request. In this section we will focus on using the EDMA for the data phase of a NAND access.

There are two conditions that require care to be taken when performing NAND reads and writes via the EDMA. These are:

- CLE_EM_A[2] and ALE_EM_A[1] are lower address lines and must be driven low
- The EMIF does not support a constant address mode, but only supports linear incrementing address modes.

Since the EMIF does not support a constant addressing mode, when programming the EDMA, a linear incrementing address mode must be used. When using a linear incrementing address mode, since the CLE and ALE are driven by lower address lines, care must be taken not to increase the address into a range that drives CLE and/or ALE high. To prevent the address from incrementing into a range that drives CLE and/or ALE high, the EDMA ACNT, BCNT, SIDX, DIDX, and synchronization type must be programmed appropriately. The proper EDMA configurations are described below.

EDMA setup for a NAND Flash data read:

- ACNT ≤ 8 bytes (this can also be set to less than or equal to the external data bus width)
- BCNT = transfer size in bytes/ACNT
- SIDX (source index) = 0
- DIDX (destination index) = ACNT
- AB synchronized

EDMA setup for a NAND Flash data write:

- ACNT ≤ 8 bytes (this can also be set to less than or equal to the external data bus width)
- BCNT = transfer size in bytes/ACNT
- SIDX (source index) = ACNT
- DIDX (destination index) = 0
- AB synchronized

2.5.6.6 ECC Generation

2.5.6.6.1 1-Bit ECC

If the CS_nNAND bit in the NAND Flash control register (NANDFCR) is set to 1, the EMIF supports ECC calculation for up to 512 bytes for the corresponding chip select. To perform the ECC calculation, the CS_nECC bit in NANDFCR must be set to 1. The ECC calculation for each chip select space is independent of each other. It is the responsibility of the software to start the ECC calculation by writing to the CS_nECC bit prior to issuing a write or read to NAND Flash *n*. It is also the responsibility of the software to read the calculated ECC from the NAND Flash *n* ECC register (NANDF_nECC) once the transfer to NAND Flash has completed. If the software writes or reads more than 512 bytes, the ECC will be incorrect. There is a NANDF_nECC for each chip select space and when read, the corresponding CS_nECC bit in NANDFCR is cleared. The NANDF_nECC is cleared upon writing a 1 to the CS_nECC bit. Figure 9 shows the algorithm used to calculate the ECC value for an 8-bit NAND Flash.

For an 8-bit NAND Flash p1e through p4e are column parities and p8e through p2048 are row parities. Similarly, the algorithm can be extended to a 16-bit NAND Flash. For a 16-bit NAND Flash p1e through p8e are column parities and p16e through p2048 are row parities. The software must ignore the unwanted parity bits if ECC is desired for less than 512 bytes of data. For example, p2048e and p2048o are not required for ECC on 256 bytes of data. Similarly, p1024e, p1024o, p2048e, and p2048o are not required for ECC on 128 bytes of data.

Figure 9. ECC Value for 8-Bit NAND Flash

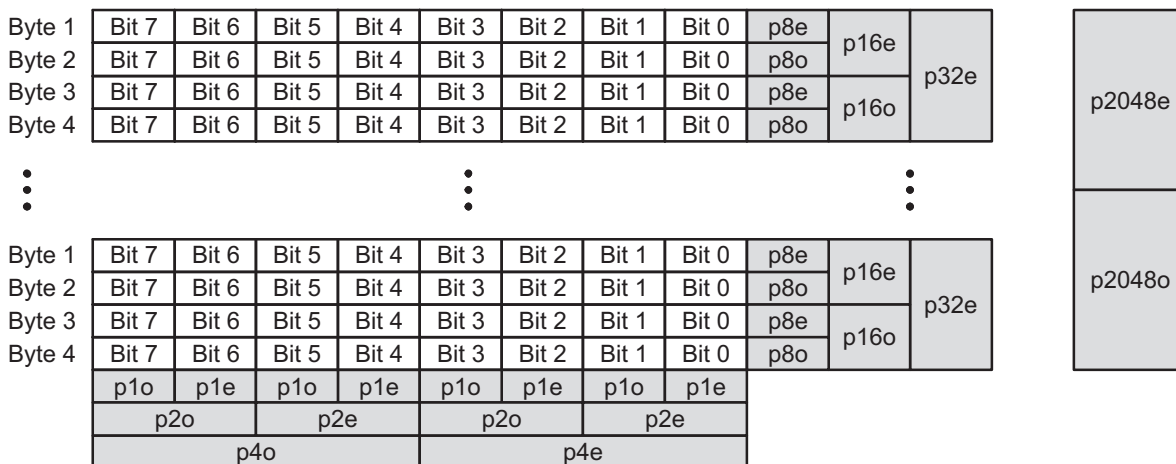

2.5.6.6.2 4-Bit ECC

The EMIF supports 4-bit ECC only for 8-bit NAND Flash. In NAND mode, if the NAND Flash 4-bit ECC

start bit (4BITECC_START) in the in the NAND Flash Control register (NANDFCR) is set, the EMIF calculates 4-bit ECC for the selected chip select. Only one chip select can be selected for the 4-bit ECC calculation at one time. The selection of the chip select is done by programming the 4-bit ECC CS select bit field (4BITECCSEL) in the NAND Flash Control register (NANDFCR). The calculated parity (for writes) and syndrome (for reads) can be read from the NAND Flash 4-Bit ECC 1-4 registers (NAND4BITECC[4:1]). The 4-bit ECC start bit (4BITECC_START) is cleared upon reading any of the NAND Flash 4-bit ECC 1-4 registers (NAND4BITECC[4:1]). The NAND Flash 4-Bit ECC 1-4 registers are cleared upon writing one to the 4-bit ECC start bit (4BITECC_START).

The 4-bit ECC algorithm works on a 10-bit data bus. Since the 4-bit ECC is only used for an 8-bit NAND Flash, the EMIF zeros the upper two bits. However, the parity and the syndrome value read from the NAND Flash 4-bit ECC 1-4 registers (NAND4BITECC[4:1]) are 10 bits wide. It is the responsibility of software to convert 10-bit parity values to 8 bits before writing to the spare location of the NAND Flash after a write operation. Similarly, it is the responsibility of software of the software to convert the 8-bit parity values read from the spare location of the NAND Flash after a read operation, to 10 bits before writing the NAND Flash 4-bit ECC Load register (NAND4BITECCLOAD).

At the end of the syndrome calculation after read, the error address and the error value can be calculated by setting the address and error value calculation start bit (4BITECC_ADD_CALC_START) in the NAND Flash Control register (NANDFCR). The end of address calculation is flagged by the 4-bit ECC correction state field (ECC_STATE) in the NAND Flash Status register (NANDFSR). The number of errors can be read from the 4-bit number of errors field (ECC_ERRNUM) in the NAND Flash Status register (NANDFSR). The error address value can be read from the NAND Flash Error Address 1-2 registers (NANDERRADD[2:1]). The error value can be read from the NAND Flash Error Address Value 1-2 registers (NANDERRVAL[2:1]). The address and error value start bit (4BITECC_ADD_CALC_START) is cleared upon reading any of the NAND Flash Error Address 1-2 registers (NANDERRADD[2:1]) or the NAND Flash Error Value 1-2 registers (NANDERRVAL[2:1]). The EMIF registers the syndrome value internally before the error address and error value calculation. Therefore, a new read operation can be performed simultaneously with the error address calculation.

The EMIF supports 4-bit ECC calculation up to 518 bytes. The software needs to follow the following procedure for 4-bit ECC calculation:

For writes:

1. Set the (4BITECC_START) bit in the NAND Flash Control register (NANDFCR) to 1.
2. Write 518 bytes of data to the NAND Flash.
3. Read the parity from the NAND Flash 4-Bit ECC 1-4 registers (NAND4BITECC[4:1]).
4. Convert the 10-bit parity values to 8-bits. All 10-bit parity values can be concatenated together with ECC value 1 (4BITECCVAL1) as lsb and ECC value 8 (4BITECCVAL8) as msb. Then the concatenated value can be broken down into ten 8-bit values.
5. Store the parity to spare location in the NAND Flash.

For reads:

1. Set the (4BITECC_START) bit in the NAND Flash Control register (NANDFCR) to 1.
2. Read 518 bytes of data from the NAND Flash.
3. Clear the (4BITECC_START) bit in the NAND Flash Control register (NANDFCR) by reading any of the NAND Flash 4-Bit ECC registers.
4. Read the parity stored in the spare location in the NAND Flash.
5. Convert the 8-bit parity values to 10-bits. Reverse of the conversion that was done during writes.
6. Write the parity values in the NAND Flash 4-bit ECC Load register (NAND4BITECCLOAD). Write each parity value one at a time starting from 4BITECCVAL8 to 4BITECCVAL1.
7. Perform a dummy read to the NAND Flash Status register (NANDFSR). This is only required to ensure time for syndrome calculation after writing the ECC values in step 6.
8. Read the syndrome from the NAND Flash 4-Bit ECC 1-4 registers (NAND4BITECC[4:1]). A syndrome value of 0 means no bit errors. If the syndrome is non-zero continue to step 9.
9. Clear any previous address calculation by doing a dummy read of an error address register. Then, set the (4BITECC_ADD_CALC_START) in the NAND Flash Control register (NANDFCR) to 1.
10. Start another read from NAND if required (a new thread from step 1).

11. Wait for the 4-bit ECC correction state field (ECC_STATE) in the NAND Flash Status register (NANDFSR) to be equal to 0x1, 0x2, or 0x3. When five or more errors are encountered, do a read of a NAND error value register. Not doing so will result in ECC error correction to stop taking place.
12. The number of errors can be read from the 4-bit number of errors field (ECC_ERRNUM) in the NAND Flash Status register (NANDFSR).
13. Read the error address from the NAND Flash Error Address 1-2 registers (NANDERRADD[2:1]). Address for the errored word is equal to (total_words_read + 7 - address_value). For 518 bytes, the address will be equal to (525 - address_value).
14. Read the error value from the NAND Flash Error Value 1-2 registers (NANDERRVAL[2:1]). Errors can be corrected by XORing the errored word with the error value from the NAND Flash Error Value 1-2 registers (NANDERRVAL[2:1]).

2.5.6.7 NAND Flash Status Register (NANDFSR)

The NAND Flash status register (NANDFSR) indicates the raw status of the EM_WAIT pin. The EM_WAIT pin should be connected to the NAND Flash device's R/ \bar{B} signal, so that it indicates whether or not the NAND Flash device is busy. During a read, the R/ \bar{B} signal will transition and remain low while the NAND Flash retrieves the data requested. Once the R/ \bar{B} signal transitions high, the requested data is ready and should be read by the EMIF. During a write/program operation, the R/ \bar{B} signal transitions and remains low while the NAND Flash is programming the Flash with the data it has received from the EMIF. Once the R/ \bar{B} signal transitions high, the data has been written to the Flash and the next phase of the transaction may be performed. From this explanation, you can see that the NAND Flash status register is useful to the software for indicating the status of the NAND Flash device and determining when to proceed to the next phase of a NAND Flash operation.

When a rising edge occurs on the EM_WAIT pin, the EMIF sets the WR (wait rise) bit in the EMIF interrupt raw register (EIRR). Therefore, the EMIF wait rise interrupt may be used to indicate the status of the NAND Flash device. The WP0 bit in the asynchronous wait cycle configuration register (AWCCR) does not affect the NAND Flash status register (NANDFSR) or the WR bit in EIRR. See [Section 2.5.11.1](#) for more a detailed description of the wait rise interrupt.

2.5.6.8 Interfacing to a Non-CE Don't Care NAND Flash

As explained in [Section 2.5.6.4](#), the EMIF does not support NAND Flash devices that require the chip select signal to remain low during the t_{r} time for a read. One way to work around this limitation is to use a GPIO pin to drive the CE signal of the NAND Flash device. If this work around is implemented, software will configure the selected GPIO to be low, then begin the NAND Flash operation, starting with the command phase. Once the NAND Flash operation has completed the software will configure the selected GPIO to be high. The pins EM_CE[3:2] are multiplexed with GPIO pins and can be used for this workaround. Refer to the device-specific data manual for more information on pin multiplexing.

2.5.7 OneNAND Flash Mode

The EMIF supports 16-bit non-multiplexed OneNAND Flash on its asynchronous interface. All OneNAND Flash asynchronous operations can be divided into single asynchronous cycles, and can be performed using the EMIF's asynchronous interface. The EMIF also supports synchronous OneNAND Flash read operations.

If the OneNAND Flash enable bit (CSnONENANDSEL) in the OneNAND Flash Control register (ONENANDCTL) is set, then the EMIF operates in OneNAND Flash mode for the corresponding chip select. The OneNAND Flash asynchronous timing values must be programmed in the corresponding Async Config register (AnCR) for the chip select. OneNAND mode cannot be used with the Extended Wait mode.

The EMIF by default is in OneNAND asynchronous read mode after reset. To use OneNAND synchronous reads, the read mode bit (CSnONENANDRDMOD) in the OneNAND Flash Control register (ONENANDCTL) must be set to 1 for the corresponding chip select. This bit must be set after putting the OneNAND device into synchronous read mode because the OneNAND device is in asynchronous read mode after power-up.

The read latency for synchronous reads must be programmed in the synchronous mode read latency bit field (RD_LATENCY) in the OneNAND Flash Control register (ONENANDCTL). The same read latency is used for all OneNAND Flashes connected to the interface. The read latency bit field (RD_LATENCY) defaults to a value of 4 after reset. If the read latency bit field (RD_LATENCY) needs to be changed, it must be written after programming the OneNAND device's internal read latency because the OneNAND device powers up with a read latency of 4.

The NAND Flash Status register (NANDFSR) indicates the raw status of the EM_WAIT pin, and can be used to determine the status of the OneNAND Flashes connected to the respective EM_WAIT pin. The EMIF sets the wait rise (WR) bits in the Interrupt Raw register on a rising edge of EM_WAIT pin. The interrupts can be used to indicate that the OneNAND Flashes connected to the respective EM_WAIT pin are ready. The MEWC bits in the Asynch Wait Cycle Config register (AWCCR) have no effect on the wait status bit (WAITST) in the NAND Flash Status register (NANDFSR) or the wait rise (WR) bits in the Interrupt Raw register (EIRR). The EM_WAIT pin should be connected to the OneNAND Flash device's INT signal.

See figures below for OneNAND connection diagrams.

Figure 10. Connecting to a 16-Bit OneNAND Flash in Asynchronous Read Mode

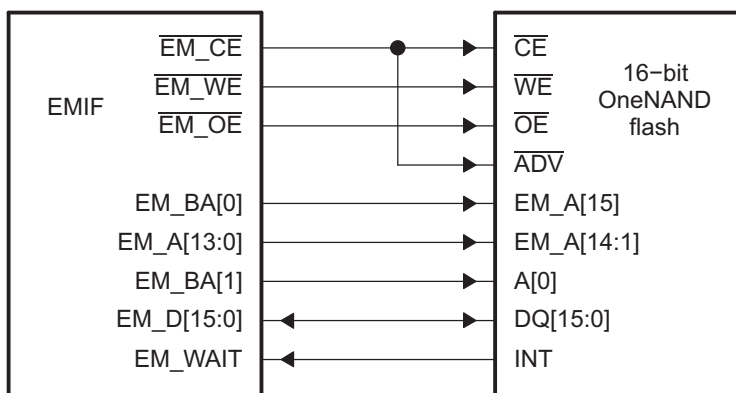
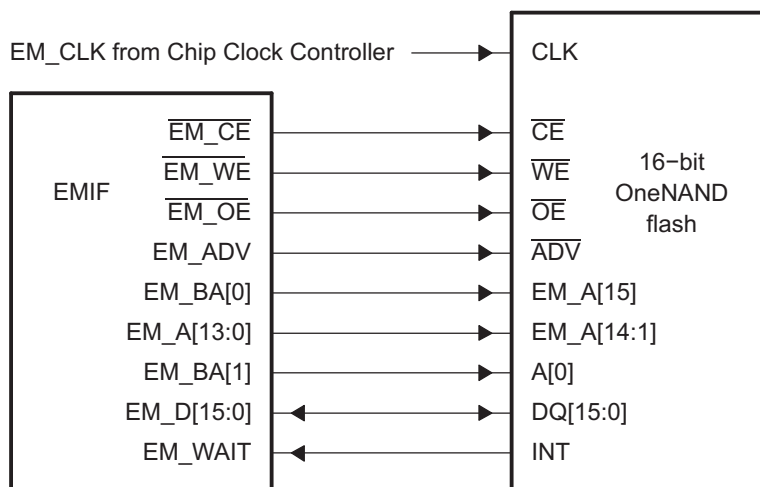

Figure 11. Connecting to a 16-Bit OneNAND Flash in Synchronous Read Mode



2.5.8 Extended Wait Mode and the EM_WAIT Pin

The Extended Wait mode is a mode in which the external asynchronous device may assert control over the length of the strobe period. The Extended Wait mode can be entered by setting the EW bit in the asynchronous configuration register (AnCR). When the EW bit is set, the EMIF monitors the EM_WAIT pin to determine if the attached device wishes to extend the strobe period of the current access cycle beyond the programmed number of clock cycles.

When the EMIF detects that the EM_WAIT pin has been asserted, it will begin inserting extra strobe cycles into the operation until the EM_WAIT pin is deactivated by the external device. The EMIF will then return to the last cycle of the programmed strobe period and the operation will proceed as usual from this point. Refer to the device-specific data manual for details on the timing requirements of the EM_WAIT signal.

The EM_WAIT pin cannot be used to extend the strobe period indefinitely. The programmable MEWC bit in the asynchronous wait cycle configuration register (AWCCR) determines the maximum number of EMIF clock cycles the strobe period may be extended beyond the programmed length. When the number of cycles programmed in the MEWC bit expires, the EMIF proceeds to the hold period of the operation regardless of the state of the EM_WAIT pin. The EMIF can also generate an interrupt upon expiration of this counter.

For the EMIF to function properly in the Extended Wait mode, the WPO bit in AWCCR must be programmed to match the polarity of the attached device. When WPO is in its reset state of 1, the EMIF will insert wait cycles when the EM_WAIT pin is sampled high; when WPO is cleared to 0, the EMIF will insert wait cycles only when the EM_WAIT pin is sampled low. This programmability allows for a glueless connection to larger variety of asynchronous devices.

Finally, a restriction is placed on the setup and strobe period timing parameters when operating in Extended Wait mode. Specifically, the sum of the W_SETUP and W_STROBE fields must be greater than 4, and the sum of the R_SETUP and R_STROBE fields must be greater than 4 for the EMIF to recognize the EM_WAIT pin has been asserted. The W_SETUP, W_STROBE, R_SETUP, and R_STROBE fields are in *AnCR*.

Figure 12. Timing Waveform of an Asynchronous Read Cycle in Normal Mode with Extended Wait

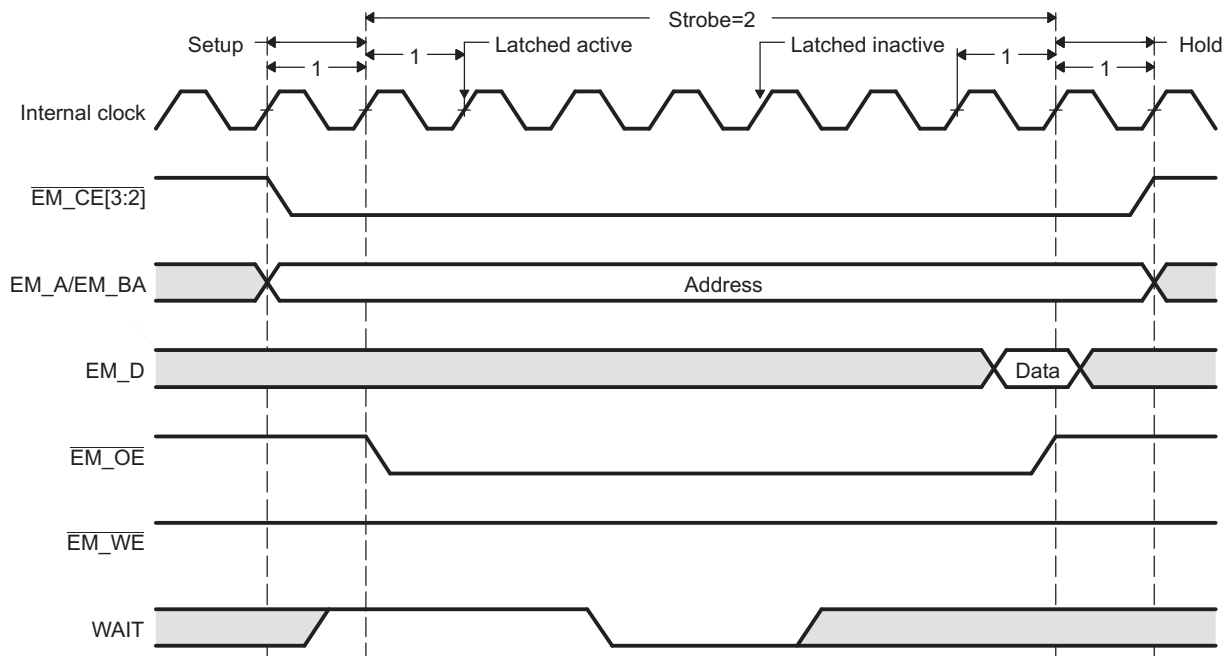
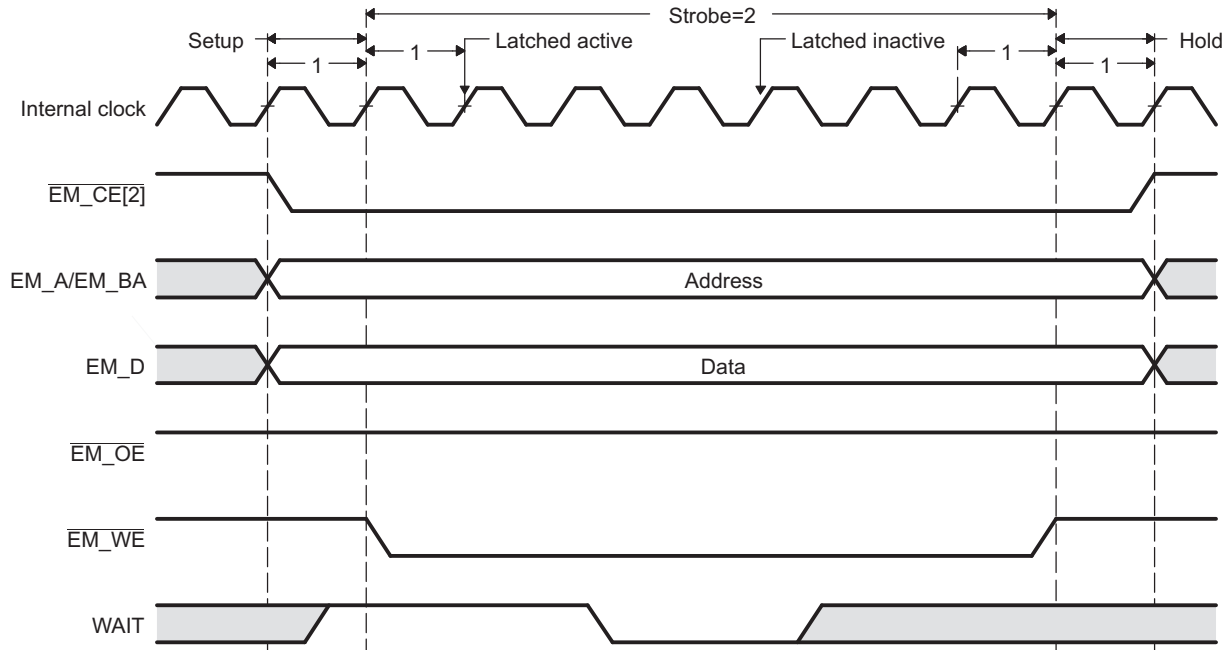

Figure 13. Timing Waveform of an Asynchronous Write Cycle in Normal Mode with Extended Wait

2.5.9 Data Bus Parking

The EMIF always drives the data bus to the previous write data value when it is idle. This feature is called data bus parking. Only when the EMIF issues a read command to the external memory does it stop driving the data bus. After the EMIF latches the last read data, it immediately parks the data bus again.

2.5.10 Reset and Initialization Considerations

The EMIF and its registers will be reset when any of the following events occur:

- The RESET pin on the device is asserted
- The EMIF is placed in reset by the Power and Sleep Controller.

When a reset occurs, the EMIF will immediately abandon any access request that is in progress and reset all registers and internal logic to their default state. Following device power up and deassertion of the RESET pin, the internal clock to the EMIF is turned on and the EMIF memory-mapped registers are programmed to their default values.

2.5.11 Interrupt Support

The EMIF supports a single interrupt to the CPU. [Section 2.5.11.1](#) details the generation and internal masking of EMIF interrupts and [Section 2.5.11.2](#) describes how the EMIF interrupts are sent to the CPU.

2.5.11.1 Interrupt Events

There are two conditions that may cause the EMIF to generate an interrupt to the CPU. These two conditions are:

- A rising edge on the EM_WAIT signal (wait rise interrupt)
- An asynchronous time out

The wait rise interrupt is not affected by the WP0 bit in the asynchronous wait cycle configuration register (AWCCR). The asynchronous time out interrupt condition occurs when the attached asynchronous device fails to deassert the EM_WAIT pin within the number of cycles defined by the MEWC bit in AWCCR.

Only when the interrupt is enabled by setting the appropriate bit (WRMSET or ATMSET) in the EMIF

interrupt mask set register (EIMSR) to 1, will the interrupt be sent to the CPU. Once enabled, the interrupt may be disabled by writing a 1 to the corresponding bit in the EMIF interrupt mask clear register (EIMCR). The bit fields in both the EIMSR and EIMCR may be used to indicate whether the interrupt is enabled. When the interrupt is enabled, the corresponding bit field in both the EIMSR and EIMCR will have a value of 1; when the interrupt is disabled, the corresponding bit field will have a value of 0.

The EMIF interrupt raw register (EIRR) and the EMIF interrupt mask register (EIMR) indicate the status of each interrupt. The appropriate bit (WR or AT) in EIRR is set when the interrupt condition occurs, whether or not the interrupt has been enabled. Whereas, the appropriate bit (WRM or ATM) in EIMR is set only when the interrupt condition occurs and the interrupt is enabled. Writing a 1 to the bit in EIRR clears the EIRR bit as well as the corresponding bit in EIMR.

Table 13 contains a brief summary of the interrupt status and control bit fields. See Section 4 for complete details on the register fields.

Table 13. Interrupt Monitor and Control Bit Fields Register Name Bit Name Description

Register Name	Bit Name	Description
EMIF interrupt raw register (EIRR)	WR	This bit is always set when an rising edge on the EM_WAIT signal occurs. Writing a 1 clears the WR bit as well as the WRM bit in EIMR.
	AT	This bit is always set when an asynchronous timeout occurs. Writing a 1 clears the AT bit as well as the ATM bit in EIMR.
EMIF interrupt mask register (EIMR)	WRM	This bit is only set when a rising edge on the EM_WAIT signal occurs and the interrupt has been enabled by writing a 1 to the WRMSET bit in EIMSR.
	ATM	This bit is only set when an asynchronous timeout occurs and the interrupt has been enabled by writing a 1 to the ATMSET bit in EIMSR.
EMIF interrupt mask set register (EIMSR)	WRMSET	Writing a 1 to this bit enables the wait rise interrupt.
	ATMSET	Writing a 1 to this bit enables the asynchronous timeout interrupt.
EMIF interrupt mask clear register (EIMCR)	WRCLR	Writing a 1 to this bit disables the wait rise interrupt.
	ATMCLR	Writing a 1 to this bit disables the asynchronous timeout interrupt.

2.5.11.2 Interrupt Multiplexing

The EMIF interrupt is supported by the ARM. The interrupt is multiplexed with UHPI.

2.6 Program Execution

Since the EMIF does not have byte enable or data mask pins, byte accesses to memory are not supported when the data bus width is equal to 16 bits. When performing data accesses on a 16-bit bus, this may be worked around by performing a write modify read back operation. When executing code from the EMIF, the bus width must be configured to be an 8-bit data bus.

2.7 Power Management

Power dissipation to the EMIF may be managed by gating the input clock to the EMIF off. The input clock is turned off outside of the EMIF through the use of the Power and Sleep Controller (PSC). When the PSC sends a clock stop request to the EMIF, the EMIF will complete pending transfers before issuing a clock stop acknowledge, allowing the PSC to stop the clock. See the *TMS320DM365 Digital Media System-on-Chip (DMSoC) ARM Subsystem Users Guide* ([SPRUFG5](#)) for more information.

2.8 Emulation Considerations

The operation of the EMIF is not affected when a breakpoint is reached or an emulation halt occurs.

3 Example Configuration

This section presents examples describing how to interface the EMIF to asynchronous SRAM and NAND Flash devices.

3.1 Interfacing to Asynchronous SRAM (ASRAM)

The following example describes how to interface the EMIF to the Toshiba TC55V16100FT-12 device.

3.1.1 Connecting to ASRAM

Figure 14 shows how to connect the EMIF to the TC55V16100FT-12 device. Since the EMIF does not include data mask or byte enable signals, the LB and UB signals of the ASRAM must be tied low.

Figure 14. Connecting the EMIF to the TC55V16100FT-12

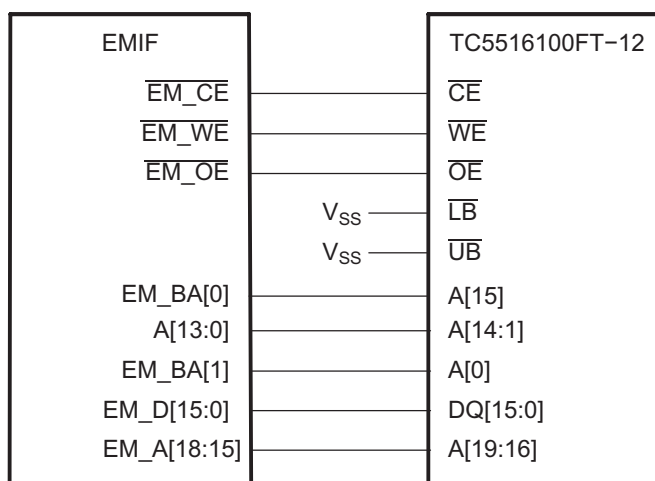

3.1.2 Meeting AC Timing Requirements for ASRAM

When configuring the EMIF to interface to ASRAM, you must consider the AC timing requirements of the ASRAM as well as the AC timing requirements of the EMIF. These can be found in the data sheet for each respective device. The read and write asynchronous cycles are programmed separately in the asynchronous configuration register (*AnCR*).

For a read access, [Table 14](#) to [Table 16](#) list the AC timing specifications that must be considered.

Table 14. EMIF Input Timing Requirements

Parameter	Description
t_{SU}	Data Setup time, data valid before $\overline{EM_OE}$ high
t_H	Data Hold time, data valid after $\overline{EM_OE}$ high

Table 15. ASRAM Output Timing Characteristics

Parameter	Description
t_{ACC}	Address Access time
t_{OH}	Output data Hold time for address change
t_{COD}	Output Disable time from chip enable

Table 16. ASRAM Input Timing Requirement for a Read

Parameter	Description
t_{RC}	Read Cycle time

shows an asynchronous read access and describes how the EMIF and ASRAM AC timing requirements work together to define the values for R_SETUP, R_STROBE, and R_HOLD.

From the following equations may be derived. t_{cyc} is the period at which the EMIF operates. The R_SETUP, R_STROBE, and R_HOLD fields are programmed in terms of EMIF cycles where as the data sheet specifications are typically given in nano seconds. This explains the presence of t_{cyc} in the denominator of the following equations. A minus 1 is included in the equations because each field in *AnCR* is programmed in terms of EMIF clock cycles, minus 1 cycle. For example, R_SETUP is equal to R_SETUP width in EMIF clock cycles minus 1 cycle.

$$R_SETUP + R_STROBE \geq \frac{(t_{ACC}(m) + t_{SU})}{t_{cyc}} - 1$$

$$R_SETUP + R_STROBE + R_HOLD \geq \frac{t_{RC}(m)}{t_{cyc}} - 3$$

$$R_HOLD \geq \frac{(t_H - t_{OH}(m))}{t_{cyc}} - 1$$

The EMIF offers an additional parameter, TA, that defines the turnaround time between read and write cycles. This parameter protects against the situation when the output turn-off time of the memory is longer than the time it takes to start the next write cycle. If this is the case, the EMIF will drive data at the same time as the memory, causing contention on the bus. By examining [Figure 15](#), the equation for TA can be derived as:

$$TA \geq \frac{t_{COD}(m)}{t_{cyc}} - 1$$

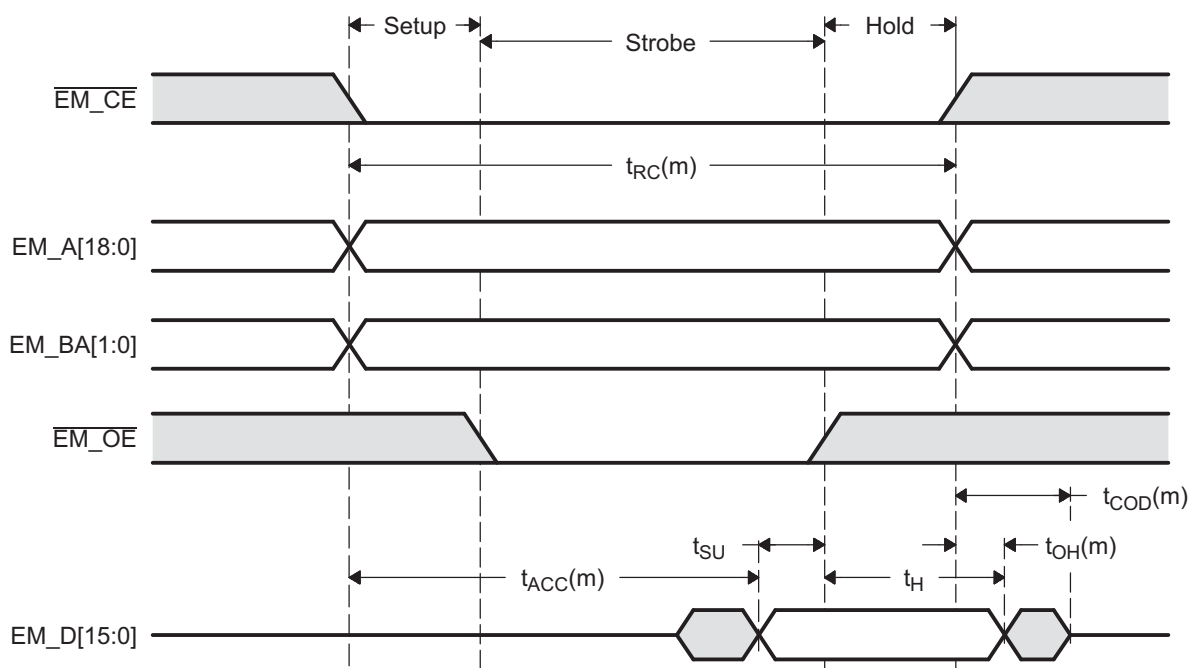
Figure 15. Timing Waveform of an ASRAM Read

For a write access, [Table 17](#) lists the AC timing specifications that must be satisfied.

Table 17. ASRAM Input Timing Requirements for a Write

Parameter	Description
t_{WP}	Write Pulse width
t_{AW}	Address valid to end of Write
t_{DS}	Data Setup time
t_{WR}	Write Recovery time
t_{DH}	Data Hold time
t_{WC}	Write Cycle time

Figure 16 shows an asynchronous write access and describes how the EMIF and ASRAM AC timing requirements work together to define values for W_SETUP, W_STROBE, and W_HOLD.

From Figure 16, the following equations may be derived. t_{cyc} is the period at which the EMIF operates. The W_SETUP, W_STROBE, and W_HOLD fields are programmed in terms of EMIF cycles where as the data sheet specifications are typically given in nano seconds. This explains the presence of t_{cyc} in the denominator of the following equations. A minus 1 is included in the equations because each field in AnCR is programmed in terms of EMIF clock cycles, minus 1 cycle. For example, W_SETUP is equal to W_SETUP width in EMIF clock cycles minus 1 cycle.

$$W_STROBE \geq \frac{t_{WP}(m)}{t_{cyc}} - 1$$

$$W_SETUP + W_STROBE \geq \max\left(\frac{t_{AW}(m)}{t_{cyc}}, \frac{t_{DS}(m)}{t_{cyc}}\right) - 1$$

$$W_HOLD \geq \max\left(\frac{t_{WR}(m)}{t_{cyc}}, \frac{t_{DH}(m)}{t_{cyc}}\right) - 1$$

$$W_SETUP + W_STROBE + W_HOLD \geq \frac{t_{WC}(m)}{t_{cyc}} - 3$$

Figure 16. Timing Waveform of an ASRAM Write

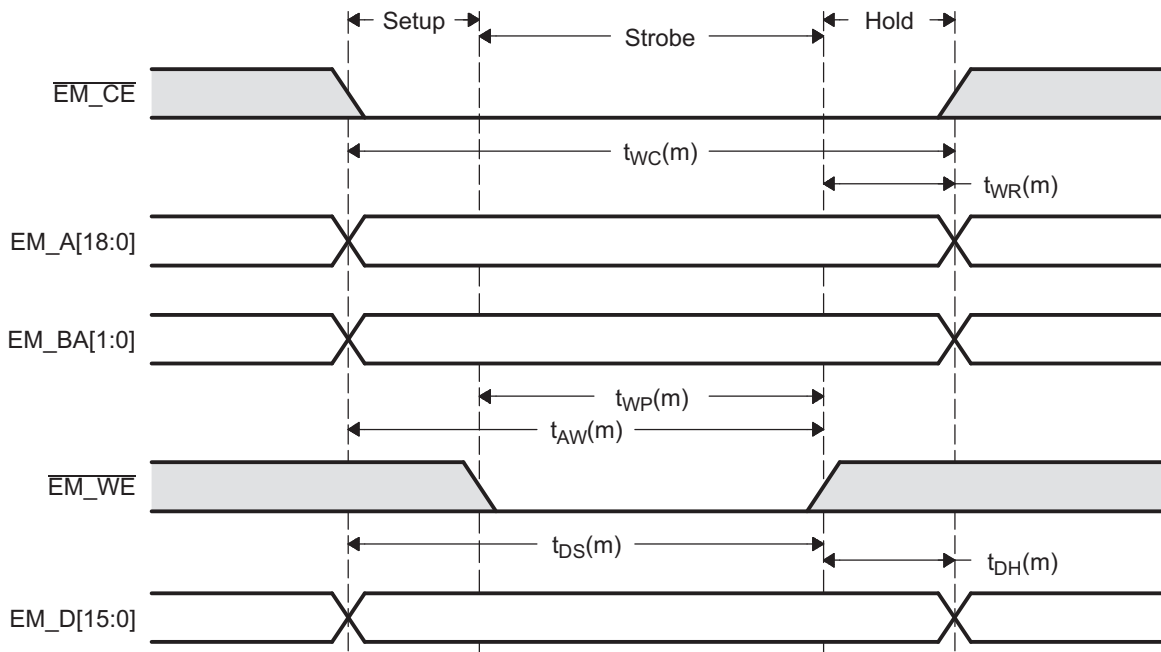

3.1.3 Taking Into Account PCB Delays

The equations described in [Section 3.1.2](#) are for the ideal case, when board design does not contribute delays. Board characteristics, such as impedance, loading, length, number of nodes, etc., affect how the device driver behaves. Signals driven by the EMIF will be delayed when they reach the ASRAM and conversely. [Table 18](#) lists the delays shown in and due to PCB affects. The PCB delays are board specific and must be estimated or determined through the use of IBIS modeling. The signals denoted (ASRAM) are the signals seen at the ASRAM. For example, $\overline{EM_CE}$ represents the signal at the EMIF and $\overline{EM_CE}$ (ASRAM) represents the delayed signal seen at the ASRAM.

Table 18. ASRAM Timing Requirements With PCB Delays

Parameter	Description
Read Access	
t_{EM_CE}	Delay on $\overline{EM_CE}$ from EMIF to ASRAM. $\overline{EM_CE}$ is driven by EMIF.
t_{EM_A}	Delay on EM_A from EMIF to ASRAM. EM_A is driven by EMIF.
t_{EM_OE}	Delay on $\overline{EM_OE}$ from EMIF to ASRAM. $\overline{EM_OE}$ is driven by EMIF.
t_{EM_D}	Delay on EM_D from ASRAM to EMIF. EM_D is driven by ASRAM.
Write Access	
t_{EM_CE}	Delay on $\overline{EM_CE}$ from EMIF to ASRAM. $\overline{EM_CE}$ is driven by EMIF.
t_{EM_A}	Delay on EM_A from EMIF to ASRAM. EM_A is driven by EMIF.
t_{EM_WE}	Delay on $\overline{EM_WE}$ from EMIF to ASRAM. $\overline{EM_WE}$ is driven by EMIF.
t_{EM_D}	Delay on EM_D from EMIF to ASRAM. EM_D is driven by EMIF.

From Figure 17, the following equations may be derived. t_{cyc} is the period at which the EMIF operates. The R_SETUP, R_STROBE, and R_HOLD fields are programmed in terms of EMIF cycles where as the data sheet specifications are typically given in nano seconds. This explains the presence of t_{cyc} in the denominator of the following equations. A minus 1 is included in the equations because each field in AnCR is programmed in terms of EMIF clock cycles, minus 1 cycle. For example, R_SETUP is equal to R_SETUP width in EMIF clock cycles minus 1 cycle.

$$R_SETUP + R_STROBE \geq \frac{(t_{EM_A} + t_{ACC}(m) + t_{SU} + t_{EM_D})}{t_{cyc}} - 1$$

$$R_SETUP + R_STROBE + R_HOLD \geq \frac{t_{RC}(m)}{t_{cyc}} - 3$$

$$R_HOLD \geq \frac{(t_H - t_{EM_D} - t_{OH}(m) - t_{EM_A})}{t_{cyc}} - 1$$

$$TA \geq \frac{(t_{EM_CE} + t_{COD}(m) + t_{EM_D})}{t_{cyc}} - 1$$

Figure 17. Timing Waveform of an ASRAM Read with PCB Delays

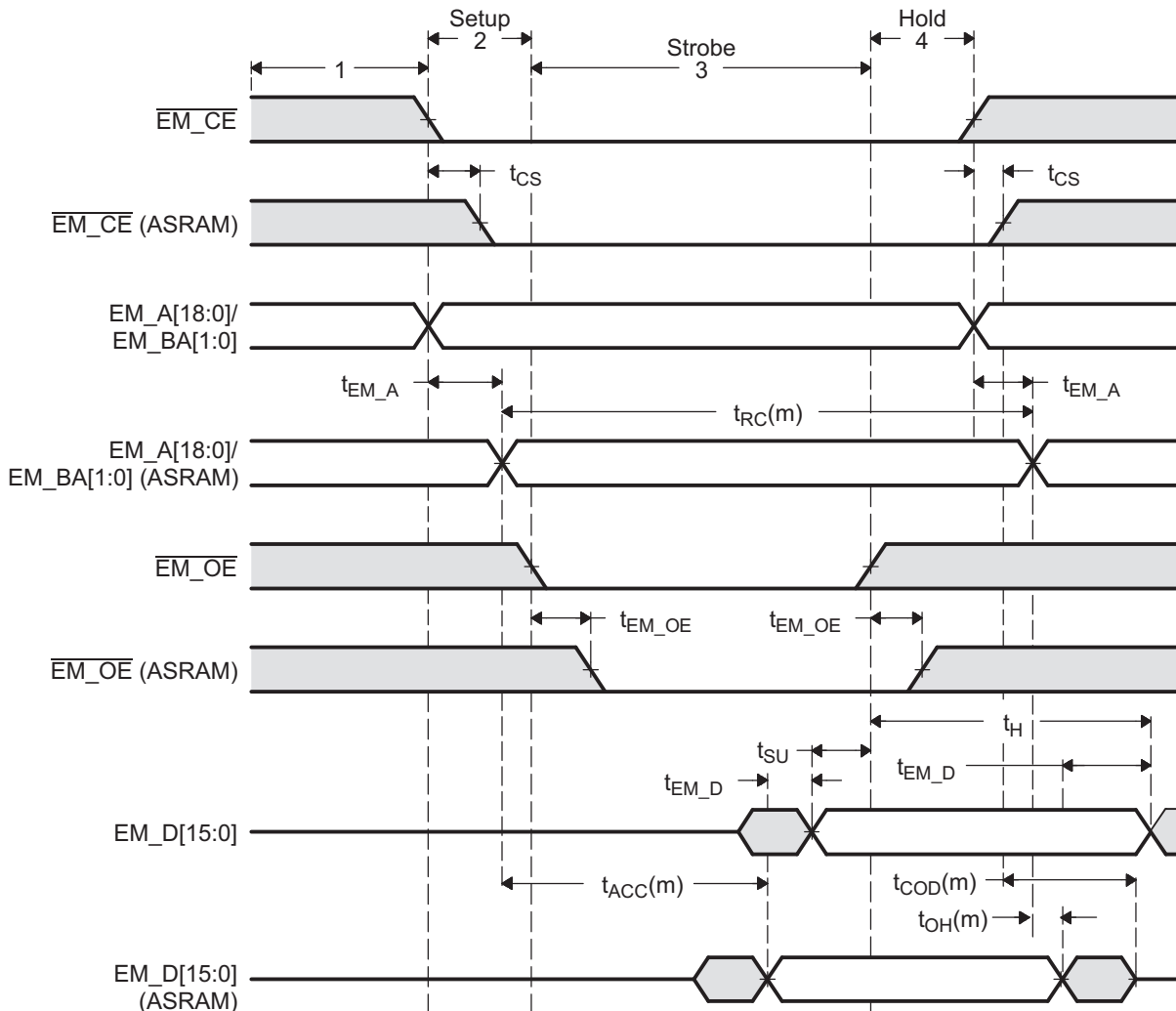

From Figure 18, the following equations may be derived. t_{cyc} is the period at which the EMIF operates. The W_SETUP , W_STROBE , and W_HOLD fields are programmed in terms of EMIF cycles where as the data sheet specifications are typically given in nano seconds. This explains the presence of t_{cyc} in the denominator of the following equations. A minus 1 is included in the equations because each field in $AnCR$ is programmed in terms of EMIF clock cycles, minus 1 cycle. For example, W_SETUP is equal to W_SETUP width in EMIF clock cycles minus 1 cycle.

$$W_STROBE \geq \frac{t_{WP}(m)}{t_{cyc}} - 1$$

$$W_SETUP + W_STROBE \geq \max\left(\frac{(t_{EM_A} + t_{AW}(m) - t_{EM_WE})}{t_{cyc}}, \frac{(t_{EM_D} + t_{DS}(m) - t_{EM_WE})}{t_{cyc}}\right) - 1$$

$$W_HOLD \geq \max\left(\frac{(t_{EM_WE} + t_{WR}(m) - t_{EM_A})}{t_{cyc}}, \frac{(t_{EM_WE} + t_{DH}(m) - t_{EM_D})}{t_{cyc}}\right) - 1$$

$$W_SETUP + W_STROBE + W_HOLD \geq \frac{t_{WC}(m)}{t_{cyc}} - 3$$

Figure 18. Timing Waveform of an ASRAM Write with PCB Delays

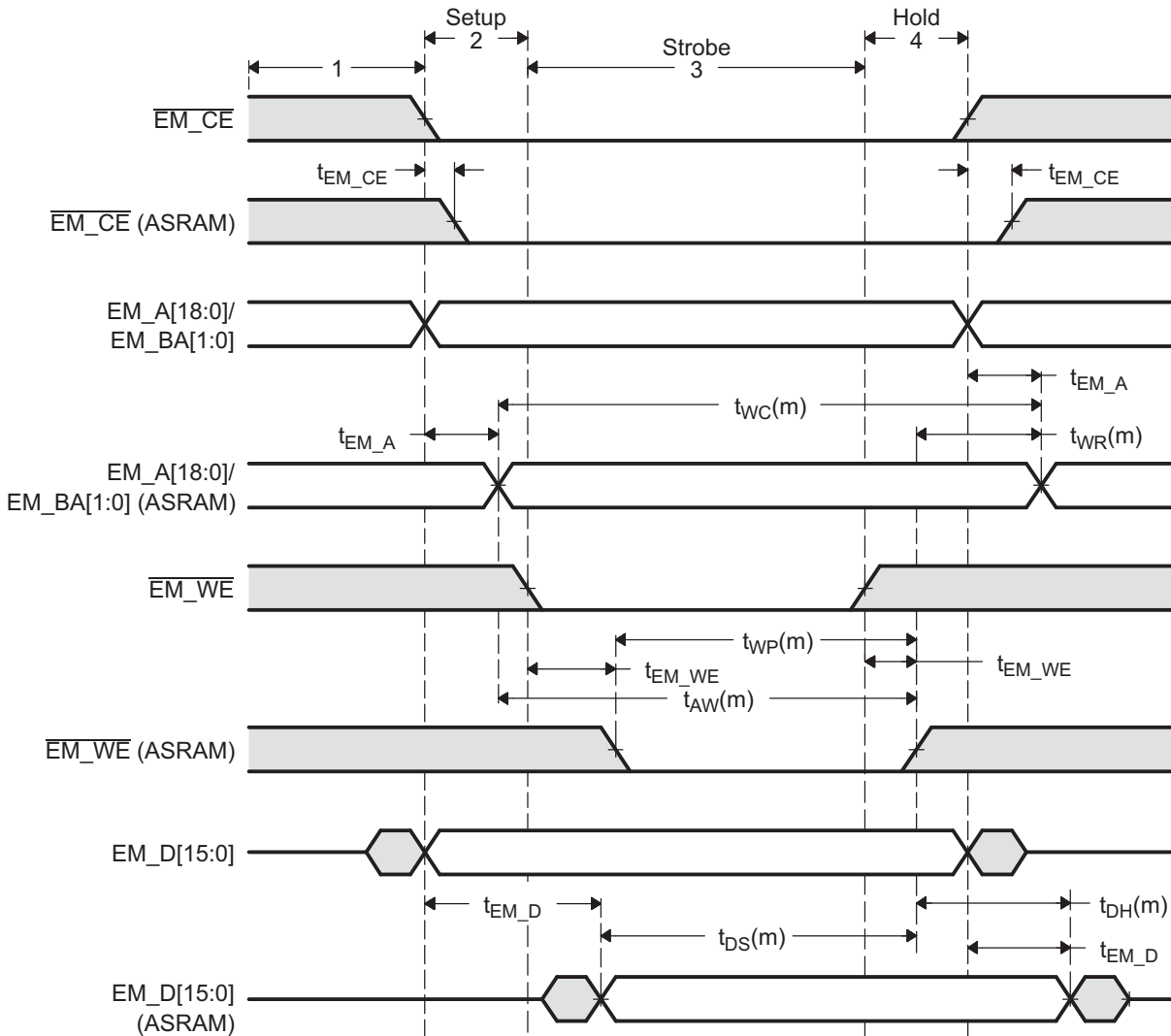

3.1.4 Example Using TC5516100FT-12

This section takes you through the configuration steps required to implement Toshiba’s TC55V1664FT-12 ASRAM with the EMIF. The following assumptions are made:

- ASRAM is connected to chip select space 3 ($\overline{EM_CE}[1]$)
- EMIF clock speed is 100 MHz ($t_{cyc} = 10 \text{ nS}$)

Table 19 lists the data sheet specifications for the EMIF and Table 20 lists the data sheet specifications for the ASRAM.

Table 19. EMIF Timing Requirements for TC5516100FT-12 Example

Parameter	Description	Min	Max	Units
t_{SU}	Data Setup time, data valid before $\overline{EM_OE}$ high	5		nS
t_H	Data Hold time, data valid after $\overline{EM_OE}$ high	0		nS

Table 20. ASRAM Timing Requirements for TC5516100FT-12 Example

Parameter	Description	Min	Max	Units
t_{ACC}	Address Access time		12	nS
t_{OH}	Output data Hold time for address change	3		nS
t_{RC}	Read cycle time	12		nS
t_{WP}	Write Pulse width	8		nS
t_{AW}	Address valid to end of Write	9		nS
t_{DS}	Data Setup time	7		nS
t_{WR}	Write Recovery time	0		nS
t_{DH}	Data Hold time	0		nS
t_{WC}	Write Cycle time	12		nS
t_{COD}	Output Disable time from chip enable		7	

Table 21 lists the values of the PCB board delays. The delays were estimated using the rule that there is 180 pS of delay for every 1 inch of trace.

Table 21. Measured PCB Delays for TC5516100FT-12 Example

Parameter	Description	Delay (ns)
Read Access		
t_{EM_CE}	Delay on $\overline{EM_CE}$ from EMIF to ASRAM. $\overline{EM_CE}$ is driven by EMIF.	0.36
t_{EM_A}	Delay on $\overline{EM_A}$ from EMIF to ASRAM. $\overline{EM_A}$ is driven by EMIF.	0.27
t_{EM_OE}	Delay on $\overline{EM_OE}$ from EMIF to ASRAM. $\overline{EM_OE}$ is driven by EMIF.	0.36
t_{EM_D}	Delay on $\overline{EM_D}$ from ASRAM to EMIF. $\overline{EM_D}$ is driven by ASRAM.	0.45
Write Access		
t_{EM_CE}	Delay on $\overline{EM_CE}$ from EMIF to ASRAM. $\overline{EM_CE}$ is driven by EMIF.	0.36
t_{EM_A}	Delay on $\overline{EM_A}$ from EMIF to ASRAM. $\overline{EM_A}$ is driven by EMIF.	0.27
t_{EM_WE}	Delay on $\overline{EM_WE}$ from EMIF to ASRAM. $\overline{EM_WE}$ is driven by EMIF.	0.36
t_{EM_D}	Delay on $\overline{EM_D}$ from EMIF to ASRAM. $\overline{EM_D}$ is driven by EMIF.	0.45

Inserting these values into the equations defined above allows you to determine the values for SETUP, STROBE, HOLD, and TA. For a read:

$$R_SETUP + R_STROBE \geq \frac{(t_{EM_A} + t_{ACC}(m) + t_{SU} + t_{EM_D})}{t_{cyc}} - 1 \geq \frac{(0.27 + 12 + 5 + 0.45)}{10} - 1 \geq 0.78$$

$$R_SETUP + R_STROBE + R_HOLD \geq \frac{t_{RC}(m)}{t_{cyc}} - 3 \geq \left(\frac{12}{10}\right) - 3 \geq -1.8$$

$$R_HOLD \geq \frac{(t_H - t_{EM_D} - t_{OH}(m) - t_{EM_A})}{t_{cyc}} - 1 \geq \frac{(0 - 0.45 - 3 - 0.27)}{10} - 1 \geq -1.37$$

Therefore if R_SETUP = 0, then R_STROBE = 0, R_HOLD = 0, and TA = 0.

For a write:

$$W_STROBE \geq \frac{t_{WP}(m)}{t_{cyc}} - 1 \geq \left(\frac{8}{10}\right) - 1 \geq -0.2$$

$$\begin{aligned} W_SETUP + W_STROBE &\geq \max\left(\frac{(t_{EM_A} + t_{AW}(m) - t_{EM_WE})}{t_{cyc}}, \frac{(t_{EM_D} + t_{DS}(m) - t_{EM_WE})}{t_{cyc}}\right) - 1 \\ &\geq \max\left(\frac{(0.36 + 0 - 0.27)}{10}, \frac{(0.36 + 0 - 0.45)}{10}\right) - 1 \geq -0.92 \end{aligned}$$

$$\begin{aligned} W_HOLD &\geq \max\left(\frac{(t_{EM_WE} + t_{WR}(m) - t_{EM_A})}{t_{cyc}}, \frac{(t_{EM_WE} + t_{DH}(m) - t_{EM_D})}{t_{cyc}}\right) - 1 \\ &\geq \max\left(\frac{(0.27 + 9 - 0.36)}{10}, \frac{(0.45 + 7 - 0.36)}{10}\right) - 1 \geq -0.1 \end{aligned}$$

$$W_SETUP + W_STROBE + W_HOLD \geq \frac{t_{WC}(m)}{t_{cyc}} - 3 \geq \left(\frac{12}{10}\right) - 3 \geq -1.8$$

Therefore, W_SETUP = 0, W_STROBE = 0, and W_HOLD = 0.

Since the value of the W_SETUP/R_SETUP, W_STROBE/R_STROBE, W_HOLD/R_HOLD, and TA fields are equal to EMIF clock cycles minus 1 cycle, the A2CR should be configured as in [Table 22](#). In this example, the EM_WAIT signal is not implemented; therefore, the asynchronous wait cycle configuration register (AWCCR) does not need to be programmed.

Table 22. Configuring A2CR for TC5516100FT-12 Example

Parameter	Setting
SS	Select Strobe mode. <ul style="list-style-type: none"> SS = 0. Places EMIF in Normal Mode.
EW	Extended Wait mode enable. <ul style="list-style-type: none"> EW = 0. Disabled Extended wait mode.
W_SETUP/R_SETUP	Read/Write setup widths. <ul style="list-style-type: none"> W_SETUP = 0 R_SETUP = 0
W_STROBE/R_STROBE	Read/Write strobe widths. <ul style="list-style-type: none"> W_STROBE = 0 R_STROBE = 0
W_HOLD/R_HOLD	Read/Write hold widths. <ul style="list-style-type: none"> W_HOLD = 0 R_HOLD = 0
TA	Minimum turnaround time. <ul style="list-style-type: none"> TA = 0
ASIZE	Asynchronous Device Bus Width. <ul style="list-style-type: none"> ASIZE = 1, select a 16-bit data bus width

3.2 Interfacing to NAND Flash

The following example explains how to interface the EMIF to the Hynix HY27UA081G1M NAND Flash device. [Section 2.5.6.2](#) describes how to connect the EMIF to the HY27UA081G1M.

3.2.1 Margin Requirements

The Flash interface is typically a low-performance interface compared to synchronous memory interfaces, high-speed asynchronous memory interfaces, and high-speed FIFO interfaces. For this reason, this example gives little attention to minimizing the amount of margin required when programming the asynchronous timing parameters. The approach used requires approximately 10 ns of margin on all parameters, which is not significant for a 100-ns read or write cycle. For additional details on minimizing the amount of margin, see the ASRAM example given in [Section 3.1](#).

Table 23. Recommended Margins

Timing Parameter	Recommended Margin
Output Setup	10 nS
Output Hold	10 nS
Input Setup	10 nS
Input Hold	10 nS

3.2.2 Meeting AC Timing Requirements for NAND Flash

When configuring the EMIF to interface to NAND Flash, you must consider the AC timing requirements of the NAND Flash as well as the AC timing requirements of the EMIF. These can be found in the data sheet for each respective device. The read and write asynchronous cycles are programmed separately in the asynchronous configuration register (*AnCR*).

As described in [Section 2.5.6](#), a NAND Flash access cycle is composed of a command, address, and data phases. The EMIF will not automatically generate these three phases to complete a NAND access with one transfer request. To complete a NAND access cycle, multiple single asynchronous access cycles must be completed by the EMIF. The command and address phases of a NAND Flash access cycle are asynchronous writes performed by the EMIF where as the data phase can be either an asynchronous write or a read depending on whether the NAND Flash is being programmed or read.

Therefore, to determine the required EMIF configuration to interface to the NAND Flash for a read operation, [Table 24](#) and [Table 25](#) list the AC timing parameters that must be considered.

Table 24. EMIF Read Timing Requirements

Parameter	Description
t_{SU}	Data Setup time, data valid before $\overline{EM_OE}$ high
t_H	Data Hold time, data valid after $\overline{EM_OE}$ high

Table 25. NAND Flash Read Timing Requirements

Parameter	Description
t_{RP}	Read Pulse width
t_{REA}	Read Enable Access time
t_{CEA}	Chip Enable low to output valid
t_{CHZ}	Chip Enable high to output High-Z
t_{RC}	Read Cycle time
t_{RHZ}	Read enable high to output High-Z
t_{CLR}	Command Latch low to Read enable low

[Figure 19](#) shows an asynchronous read access and describes how the EMIF and NAND Flash AC timing requirements work together to define the values for R_SETUP, R_STROBE, and R_HOLD.

From Figure 19, the following equations may be derived. t_{cyc} is the period at which the EMIF operates. The R_SETUP, R_STROBE, and R_HOLD fields are programmed in terms of EMIF cycles where as the data sheet specifications are typically given in nano seconds. This explains the presence of t_{cyc} in the denominator of the following equations. A minus 1 is included in the equations because each field in AnCR is programmed in terms of EMIF clock cycles, minus 1 cycle. For example, R_SETUP is equal to R_SETUP width in EMIF clock cycles minus 1 cycle.

$$R_SETUP \geq \frac{t_{CLR}(m)}{t_{cyc}} - 1$$

$$R_STROBE \geq \max\left(\frac{(t_{REA}(m) + t_{SU})}{t_{cyc}}, \frac{t_{RP}(m)}{t_{cyc}}\right) - 1$$

$$R_SETUP + R_STROBE \geq \frac{(t_{CEA}(m) + t_{SU})}{t_{cyc}} - 1$$

$$R_HOLD \geq \frac{(t_H - t_{CHZ}(m))}{t_{cyc}} - 1$$

$$R_SETUP + R_STROBE + R_HOLD \geq \frac{t_{RC}(m)}{t_{cyc}} - 3$$

The EMIF offers an additional parameter, TA, that defines the turnaround time between read and write cycles. This parameter protects against the situation when the output turn-off time of the memory is longer than the time it takes to start the next write cycle. If this is the case, the EMIF will drive data at the same time as the memory, causing contention on the bus. By examining Figure 19, the equation for TA can be derived as:

$$TA \geq \max\left(\frac{t_{CHZ}(m)}{t_{cyc}}, \frac{t_{RHZ}(m) - (R_HOLD + 1)t_{cyc}}{t_{cyc}}\right) - 1$$

Figure 19. Timing Waveform of a NAND Flash Read

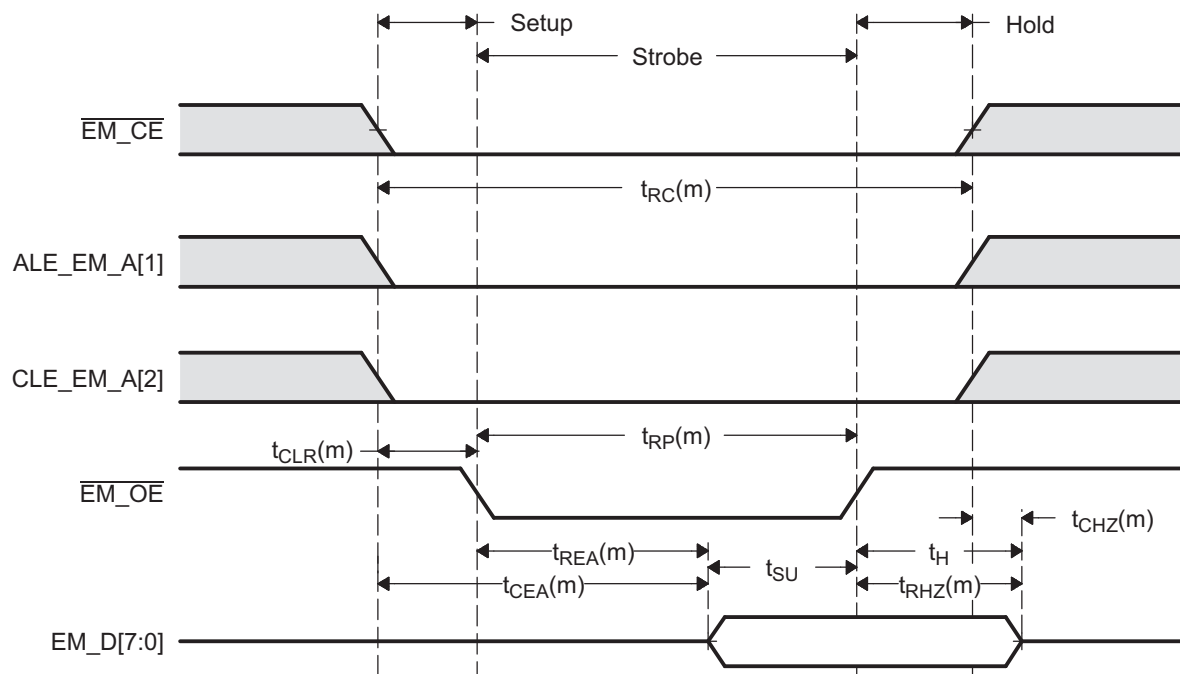

To determine the required EMIF configuration to interface to the NAND Flash for a write operation, [Table 26](#) lists the NAND AC timing parameters for a command latch, address latch, and data input latch that must be considered.

Table 26. NAND Flash Write Timing Requirements

Parameter	Description
t_{WP}	Write Pulse width
t_{CLS}	CLE Setup time
t_{ALS}	ALE Setup time
t_{CS}	\overline{CS} Setup time
t_{DS}	Data Setup time
t_{CLH}	CLE Hold time
t_{ALH}	ALE Hold time
t_{CH}	\overline{CS} Hold time
t_{DH}	Data Hold time
t_{WC}	Write Cycle time

[Figure 20](#) to [Figure 22](#) show the command latch, address latch, and data input latch of the NAND access.

From [Figure 20](#) to [Figure 22](#), the following equations may be derived. t_{cyc} is the period at which the EMIF operates. The W_SETUP, W_STROBE, and W_HOLD fields are programmed in terms of EMIF cycles where as the data sheet specifications are typically given in nano seconds. This explains the presence of t_{cyc} in the denominator of the following equations. A minus 1 is included in the equations because each field in AnCR is programmed in terms of EMIF clock cycles, minus 1 cycle. For example, W_SETUP is equal to W_SETUP width in EMIF clock cycles minus 1 cycle.

$$R_SETUP + R_STROBE + R_HOLD \geq \frac{t_{RC}(m)}{t_{cyc}} - 3$$

$$W_STROBE \geq \frac{t_{WP}(m)}{t_{cyc}} - 1$$

$$W_SETUP + W_STROBE \geq \frac{t_{DS}(m)}{t_{cyc}} - 1$$

$$W_HOLD \geq \max\left(\frac{t_{CLH}(m)}{t_{cyc}}, \frac{t_{ALH}(m)}{t_{cyc}}, \frac{t_{CH}(m)}{t_{cyc}}, \frac{t_{DH}(m)}{t_{cyc}}\right) - 1$$

$$W_SETUP + W_STROBE + W_HOLD \geq \frac{t_{WC}(m)}{t_{cyc}} - 3$$

Figure 20. Timing Waveform of a NAND Flash Command Write

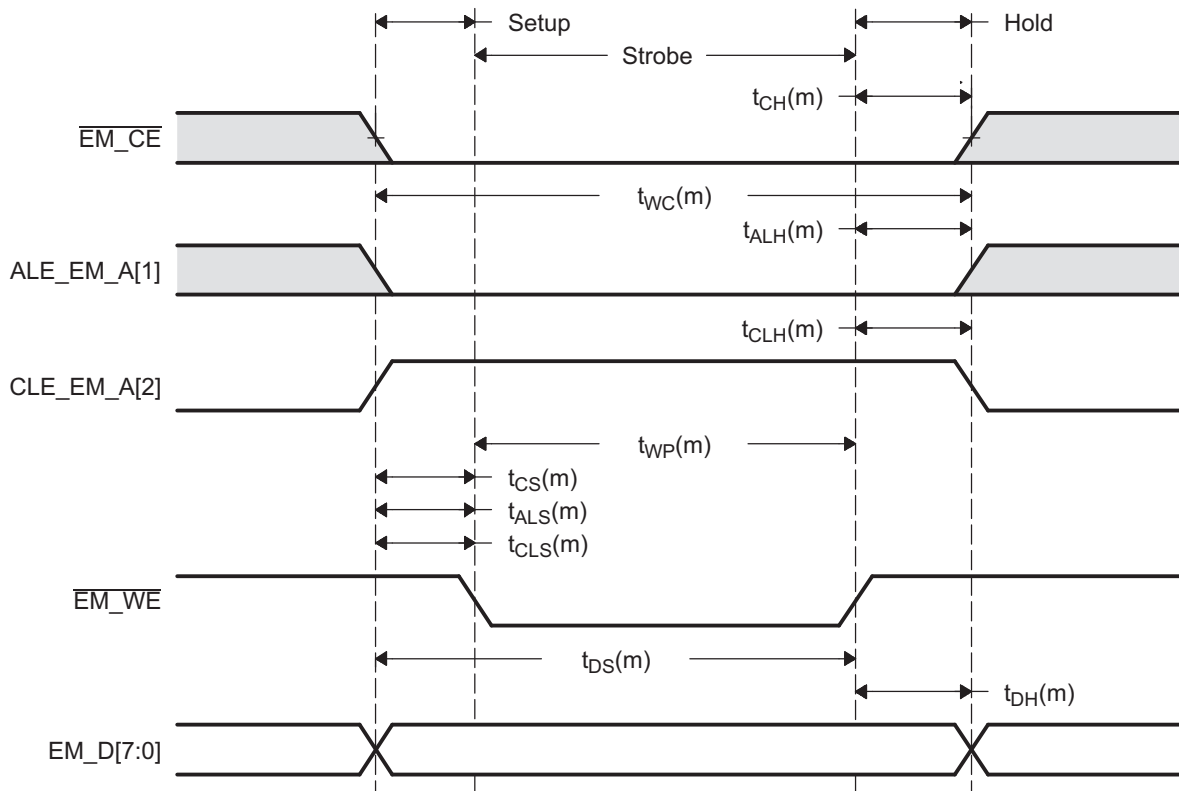

Figure 21. Timing Waveform of a NAND Flash Address Write

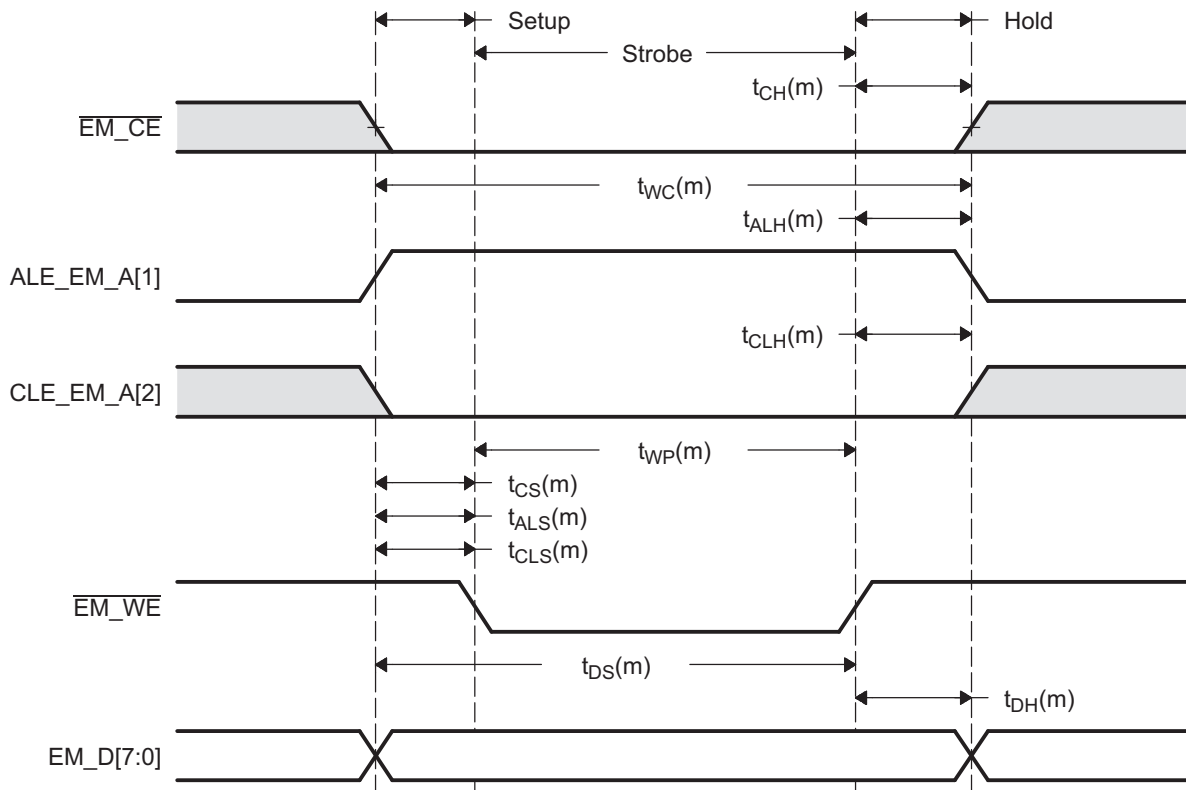
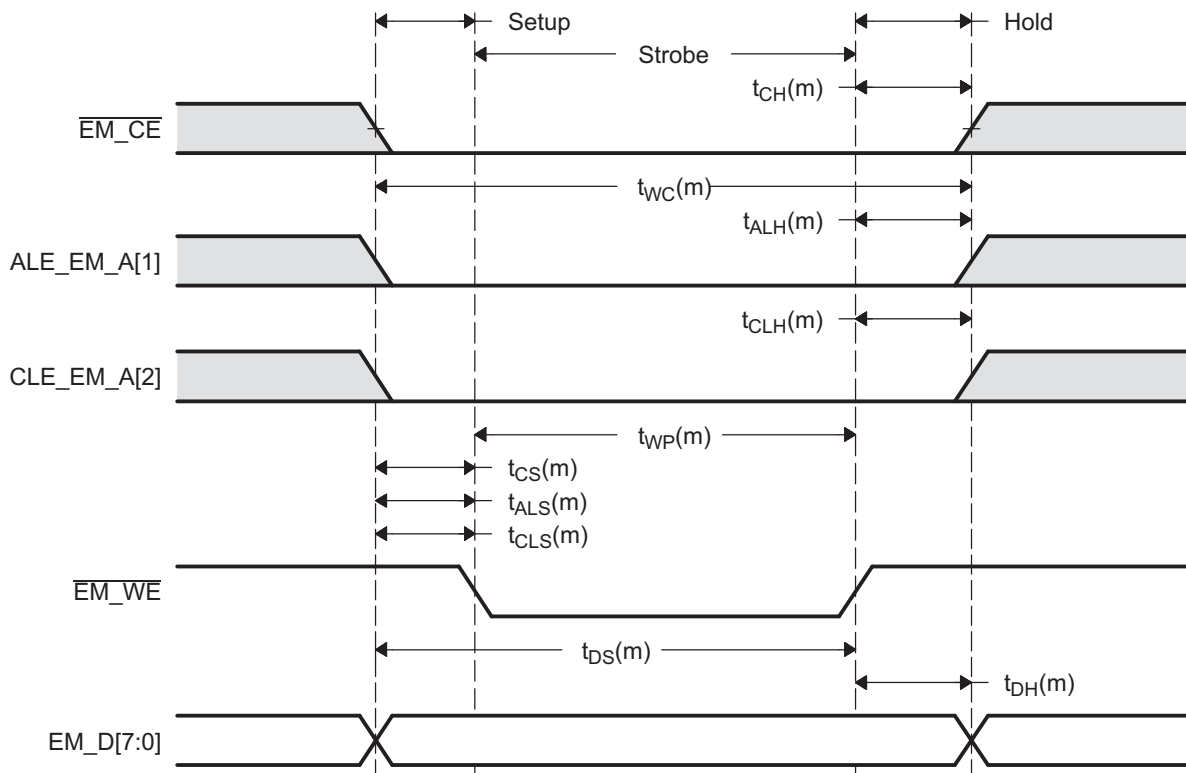

Figure 22. Timing Waveform of a NAND Flash Data Write



3.2.3 Example Using Hynix HY27UA081G1M

This section takes you through the configuration steps required to implement Hynix's HY27UA081G1M NAND Flash with the EMIF. The following assumptions are made:

- NAND Flash is connected to chip select space 2 ($\overline{\text{EM_CE}}[2]$)
- EMIF clock speed is 100 MHz ($t_{\text{cyc}} = 10 \text{ nS}$)

Table 27 lists the data sheet specifications for the EMIF and Table 28 lists the data sheet specifications for the NAND Flash.

Table 27. EMIF Timing Requirements for HY27UA081G1M Example

Parameter	Description	Min	Max	Units
t_{SU}	Data Setup time, data valid before $\overline{\text{EM_OE}}$ high	5		nS
t_{H}	Data Hold time, data valid after $\overline{\text{EM_OE}}$ high	0		nS

Table 28. NAND Flash Timing Requirements for HY27UA081G1M Example

Parameter	Description	Min	Max	Units
t_{RP}	Read Pulse width	60		nS
t_{REA}	Read Enable Access time		60	nS
t_{CEA}	Chip Enable low to output valid		75	nS
t_{CHZ}	Chip Enable high to output High-Z		20	nS
t_{RC}	Read Cycle time	80		nS
t_{RHZ}	Read Enable high to output High-Z		30	nS
t_{CLR}	Command Latch low to Read enable low	10		nS
t_{WP}	Write Pulse width	60		nS
t_{CLS}	CLE Setup time	0		nS
t_{ALS}	ALE Setup time	0		nS
t_{CS}	$\overline{\text{CS}}$ Setup time	0		nS
t_{DS}	Data Setup time	20		nS
t_{CLH}	CLE Hold time	10		nS
t_{ALH}	ALE Hold time	10		nS
t_{CH}	$\overline{\text{CS}}$ Hold time	10		nS
t_{DH}	Data Hold time	10		nS
t_{WC}	Write Cycle time	80		nS

Inserting these values into the equations defined above allows you to determine the values for SETUP, STROBE, HOLD, and TA. For a read:

$$R_SETUP \geq \frac{t_{CLR}(m)}{t_{cyc}} - 1 \geq \left(\frac{10}{10}\right) - 1 \geq 0$$

$$R_STROBE \geq \max\left(\frac{(t_{REA}(m) + t_{SU})}{t_{cyc}}, \frac{t_{RP}}{t_{cyc}}\right) - 1 \geq \left(\frac{65}{10}\right) - 1 \geq 5.5$$

$$R_SETUP + R_STROBE \geq \frac{(t_{CEA} + t_{SU})}{t_{cyc}} - 1 \geq \frac{(75 + 5)}{10} - 1 \geq 7$$

$$R_HOLD \geq \frac{(t_H - t_{CHZ}(m))}{t_{cyc}} - 1 \geq \frac{(0 - 20)}{10} - 1 \geq -3$$

$$R_SETUP + R_STROBE + R_HOLD \geq \frac{t_{RC}(m)}{t_{cyc}} - 3 \geq \left(\frac{80}{10}\right) - 3 \geq 5$$

Therefore with a 10 nS margin added in, $R_SETUP \geq 1.0$, $R_STROBE \geq 6.5$, and $R_HOLD \geq 0$.

After solving for R_HOLD , TA may be calculated:

$$TA \geq \max\left(\frac{t_{CHZ}(m)}{t_{cyc}}, \frac{t_{RHZ}(m) - (R_HOLD + 1)t_{cyc}}{t_{cyc}}\right) - 1 \geq \left(\frac{20}{10}\right) - 1 \geq 1$$

Adding a 10 ns margin, $TA \geq 2$.

For a write:

$$W_STROBE \geq \frac{t_{WP}(m)}{t_{cyc}} - 1 \geq \left(\frac{60}{10}\right) - 1 \geq 5$$

$$W_SETUP \geq \max\left(\frac{t_{CLS}(m)}{t_{cyc}}, \frac{t_{ALS}(m)}{t_{cyc}}, \frac{t_{CS}(m)}{t_{cyc}}\right) - 1 \geq \left(\frac{0}{10}\right) - 1 \geq -1$$

$$W_SETUP + W_STROBE \geq \frac{t_{DS}(m)}{t_{cyc}} - 1 \geq \left(\frac{20}{10}\right) - 1 \geq 1$$

$$W_HOLD \geq \max\left(\frac{t_{CLH}(m)}{t_{cyc}}, \frac{t_{ALH}(m)}{t_{cyc}}, \frac{t_{CH}(m)}{t_{cyc}}, \frac{t_{DH}(m)}{t_{cyc}}\right) - 1 \geq \left(\frac{10}{10}\right) - 1 \geq 0$$

$$W_SETUP + W_STROBE + W_HOLD \geq \frac{t_{WC}(m)}{t_{cyc}} - 3 \geq \left(\frac{80}{10}\right) - 3 \geq 5$$

Therefore with a 10 nS margin added in, $W_SETUP \geq 0$, $W_STROBE \geq 6$, and $W_HOLD \geq 1$.

Since the value of the W_SETUP/R_SETUP, W_STROBE/R_STROBE, W_HOLD/R_HOLD, and TA fields are equal to EMIF clock cycles minus 1 cycle, the A1CR should be configured as in [Table 29](#). In this example, although the EM_WAIT signal is connected to the R/ \bar{B} signal of the NAND Flash the Extended Wait mode of the EMIF is not used, therefore the asynchronous wait cycle configuration register (AWCCR) does not need to be programmed.

Table 29. Configuring A1CR for HY27UA081G1M Example

Parameter	Setting
SS	Select Strobe mode. <ul style="list-style-type: none"> SS = 0. Places EMIF in Normal Mode.
EW	Extended Wait mode enable. <ul style="list-style-type: none"> EW = 0. Disabled Extended wait mode.
W_SETUP/R_SETUP	Read/Write setup widths. <ul style="list-style-type: none"> W_SETUP = 0 R_SETUP = 2
W_STROBE/R_STROBE	Read/Write strobe widths. <ul style="list-style-type: none"> W_STROBE = 6 R_STROBE = 7
W_HOLD/R_HOLD	Read/Write hold widths. <ul style="list-style-type: none"> W_HOLD = 1 R_HOLD = 0
TA	Minimum turnaround time. <ul style="list-style-type: none"> TA = 2
ASIZE	Asynchronous device bus width. <ul style="list-style-type: none"> ASIZE = 0, select an 8-bit data bus width.

Since this is a NAND Flash example, the EMIF must be configured for NAND Flash mode. This is accomplished by configuring the NAND Flash control register (NANDFCR) as in [Table 30](#). In NANDFCR, chip select space 2 must be configured with NAND Flash mode enabled.

Table 30. Configuring NANDFCR for HY27UA081G1M Example

Parameter	Setting
CS3ECC	NAND Flash ECC start for chip select 3. <ul style="list-style-type: none"> CS3ECC = 0. Not set during configuration. Only set just prior to reading or writing data.
CS2ECC	NAND Flash ECC start for chip select 2. <ul style="list-style-type: none"> CS2ECC = 0. Not set during configuration. Only set just prior to reading or writing data.
CS3NAND	NAND Flash mode for chip select 3. <ul style="list-style-type: none"> CS3NAND = 0. NAND Flash mode is disabled.
CS2NAND	NAND Flash mode for chip select 2. <ul style="list-style-type: none"> CS5NAND = 1. NAND Flash mode is enabled.

4 Registers

The external memory interface (EMIF) is controlled by programming its internal memory-mapped registers (MMRs). [Table 31](#) lists the memory-mapped registers for the EMIF. See the device-specific data manual for the memory address of these registers. All other register offset addresses not listed in [Table 31](#) should be considered as reserved locations and the register contents should not be modified.

NOTE: The EMIF MMRs only support word (4 byte) accesses. Performing a byte (8-bit) or halfword (16-bit) write to a register results in unknown behavior.

Table 31. External Memory Interface (EMIF) Registers

Offset	Acronym	Register Description	Section
04h	AWCCR	Asynchronous Wait Cycle Configuration Register	Section 4.1
10h	A1CR	Asynchronous 1 Configuration Register (CS2 space)	Section 4.2
14h	A2CR	Asynchronous 2 Configuration Register (CS3 space)	Section 4.2
40h	EIRR	EMIF Interrupt Raw Register	Section 4.3
44h	EIMR	EMIF Interrupt Mask Register	Section 4.4
48h	EIMSR	EMIF Interrupt Mask Set Register	Section 4.5
4Ch	EIMCR	EMIF Interrupt Mask Clear Register	Section 4.6
5Ch	ONENANDCTL	OneNAND Flash Control Register	Section 4.7
60h	NANDFCR	NAND Flash Control Register	Section 4.8
64h	NANDFSR	NAND Flash Status Register	Section 4.9
70h	NANDF1ECC	NAND Flash 1-Bit ECC Register 1 (CS2 Space)	Section 4.10
74h	NANDF2ECC	NAND Flash 1-Bit ECC Register 2 (CS3 Space)	Section 4.10
BCh	NAND4BITECCLOAD	NAND Flash 4-Bit ECC Load Register	Section 4.11
C0h	NAND4BITECC1	NAND Flash 4-Bit ECC Register 1	Section 4.12
C4h	NAND4BITECC2	NAND Flash 4-Bit ECC Register 2	Section 4.13
C8h	NAND4BITECC3	NAND Flash 4-Bit ECC Register 3	Section 4.14
CCh	NAND3BITECC4	NAND Flash 4-Bit ECC Register 4	Section 4.15
D0h	NANDERRADD1	NAND Flash 4-Bit ECC Error Address Register 1	Section 4.16
D4h	NANDERRADD2	NAND Flash 4-Bit ECC Error Address Register 2	Section 4.17
D8h	NANDERRVAL1	NAND Flash 4-Bit ECC Error Value Register 1	Section 4.18
DCh	NANDERRVAL2	NAND Flash 4-Bit ECC Error Value Register 2	Section 4.19

4.1 Asynchronous Wait Cycle Configuration Register (AWCCR)

The asynchronous wait cycle configuration register (AWCCR) is used to configure the parameters for extended wait cycles. Both the polarity of the EM_WAIT pin and the maximum allowable number of extended wait cycles can be configured. The AWCCR is shown in Figure 23 and described in Table 32.

NOTE: The EW bit in the asynchronous configuration register (AnCR) must be set to allow for the insertion of extended wait cycles.

Figure 23. Asynchronous Wait Cycle Configuration Register (AWCCR)

31	29	28	27	18	17	16
Reserved		WP0	Reserved			Reserved
R-0		R/W-1	R-0			R-0
15	Reserved			8	7	0
R-0				MEWC		
R-0				R/W-80h		

LEGEND: R/W = Read/Write; R = Read only; -n = value after reset

Table 32. Asynchronous Wait Cycle Configuration Register (AWCCR) Field Descriptions

Bit	Field	Value	Description
31-29	Reserved	0	Reserved
28	WP0	0 1	WAIT polarity bit. This bit defines the polarity of the EM_WAIT pin. 0 Insert wait cycles if EM_WAIT is low. 1 Insert wait cycles if EM_WAIT is high.
27-18	Reserved	0	Reserved
17-16	Reserved	0	Reserved. The reserved bit location is always read as 0. If writing to this field, always write the default value of 0.
15-8	Reserved	0	Reserved
7-0	MEWC	0-FFh	Maximum extended wait cycles. The EMIF will wait for a maximum of (MEWC + 1) = 16 clock cycles before it stops inserting asynchronous wait cycles and proceeds to the hold period of the access.

4.2 Asynchronous Configuration Registers (A1CR-A2CR)

The asynchronous configuration register (A_nCR) is used to configure the shaping of the address and control signals during an access to asynchronous memory. It is also used to program the width of asynchronous interface and to select from various modes of operation. This register can be written prior to any transfer, and any asynchronous transfer following the write will use the new configuration. The A_nCR is shown in [Figure 24](#) and described in [Table 33](#). There are two A_nCR s. Each chip select space has a dedicated A_nCR . This allows each chip select space to be programmed independently to interface to different asynchronous memory types.

Figure 24. Asynchronous n Configuration Register (A_nCR)

31	30	29	26	25	24
SS	EW ^(A)	W_SETUP		W_STROBE ^(B)	
R/W-0	R/W-0	R/W-Fh		R/W-3Fh	
23	20		19	17	16
W_STROBE ^(B)			W_HOLD		R_SETUP
R/W-3Fh			R/W-7h		R/W-Fh
15	13	12	7	6	4
R_SETUP		R_STROBE ^(B)		R_HOLD	TA
R/W-Fh		R/W-3Fh		R/W-7h	R/W-3h
ASIZE		R/W-0			

LEGEND: R/W = Read/Write; -n = value after reset

#IMPLIED The EW bit must be cleared to 0 when operating in NAND Flash mode.

#IMPLIED The W_STROBE and R_STROBE bits must not be cleared to 0 when operating in Extended Wait mode.

Table 33. Asynchronous n Configuration Register (A_nCR) Field Descriptions

Bit	Field	Value	Description
31	SS	0 1	Select Strobe bit. This bit defines whether the asynchronous interface operates in Normal mode or Select Strobe mode. See Section 2.5 for details on the two modes of operation. Normal mode is enabled. Select Strobe mode is enabled.
30	EW	0 1	Extend Wait bit. This bit defines whether extended wait cycles will be enabled. See Section 2.5.8 on extended wait cycles for details. This bit field must be cleared to 0, if the EMIF on your device does not have a EM_WAIT pin. Extended wait cycles are disabled. Extended wait cycles are enabled.
29-26	W_SETUP	0-Fh	Write setup width in EMIF clock cycles, minus 1 cycle. See Section 2.5.3 for details.
25-20	W_STROBE	0-3Fh	Write strobe width in EMIF clock cycles, minus 1 cycle. See Section 2.5.3 for details.
19-17	W_HOLD	0-7h	Write hold width in EMIF clock cycles, minus 1 cycle. See Section 2.5.3 for details.
16-13	R_SETUP	0-Fh	Read setup width in EMIF clock cycles, minus 1 cycle. See Section 2.5.3 for details.
12-7	R_STROBE	0-3Fh	Read strobe width in EMIF clock cycles, minus 1 cycle. See Section 2.5.3 for details.
6-4	R_HOLD	0-7h	Read hold width in EMIF clock cycles, minus 1 cycle. See Section 2.5.3 for details.
3-2	TA	0-3h	Minimum Turn-Around time. This field defines the minimum number of EMIF clock cycles between the end of one asynchronous access and the start of another, minus 1 cycle. This delay is not incurred by a read followed by a read or a write followed by a write to the same CS space. See Section 2.5.3 for details.
1-0	ASIZE	0-3h 0 1h 2h-3h	Asynchronous data bus width. This bit defines the width of the asynchronous device's data bus. 8-bit data bus 16-bit data bus Reserved.

4.3 EMIF Interrupt Raw Register (EIRR)

The EMIF interrupt raw register (EIRR) is used to monitor and clear the EMIF's hardware-generated interrupts. The bits in EIRR will be set when an interrupt condition occurs regardless of the status of the EMIF interrupt mask set register (EIMSR) and EMIF interrupt mask clear register (EIMCR). Writing a 1 to these bit fields will clear them as well as the corresponding bit field in the EMIF interrupt mask register (EIMR). The EIRR is shown in Figure 25 and described in Table 34.

Figure 25. EMIF Interrupt Raw Register (EIRR)

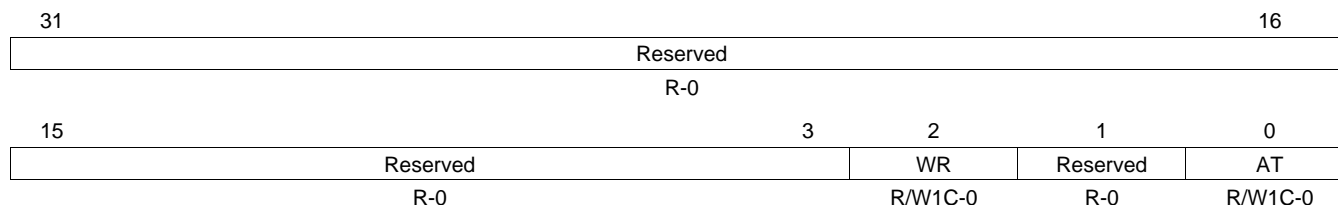

LEGEND: R/W = Read/Write; R = Read only; W1C = Write 1 to clear (writing 0 has no effect); -n = value after reset

Table 34. EMIF Interrupt Raw Register (EIRR) Field Descriptions

Bit	Field	Value	Description
31-3	Reserved	0	Reserved. The reserved bit location is always read as 0. If writing to this field, always write the default value of 0.
2	WR	0 1	Wait Rise. This bit is set to 1 by hardware to indicate that a rising edge on the EM_WAIT pin has occurred. 0 Indicates that a rising edge has not occurred on the EM_WAIT pin. Writing a 0 has no effect. 1 Indicates that a rising edge has occurred on the EM_WAIT pin. Writing a 1 will clear this bit and the WRM bit in the EMIF interrupt mask register (EIMR).
1	Reserved	0	Reserved. The reserved bit location is always read as 0. If writing to this field, always write the default value of 0.
0	AT	0 1	Asynchronous Timeout. This bit is set to 1 by hardware to indicate that during an extended asynchronous memory access cycle the EM_WAIT pin did not go inactive within the number of cycles defined by the MEWC field in the asynchronous wait cycle configuration register (AWCCR). 0 Indicates that an asynchronous timeout has not occurred. Writing a 0 has no effect. 1 Indicates that an asynchronous timeout has occurred. Writing a 1 will clear this bit and the ATM bit in the EMIF interrupt mask register (EIMR).

4.4 EMIF Interrupt Mask Register (EIMR)

Like the EMIF interrupt raw register (EIRR), the EMIF interrupt mask register (EIMR) is used to monitor and clear the status of the EMIF's hardware-generated interrupts. The main difference between the two registers is that when the bit fields in EIMR are set, an active-high pulse will be sent to the CPU interrupt controller. Also, the bit fields in EIMR are only set to 1 if the associated interrupt has been enabled in the EMIF interrupt set register (EISR). The EIMR is shown in Figure 26 and described in Table 35.

Figure 26. EMIF Interrupt Mask Register (EIMR)

31	Reserved				16	
R-0						
15	Reserved		3	2	1	0
R-0		WRM	Reserved	ATM		
		R/W1C-0	R-0	R/W1C-0		

LEGEND: R/W = Read/Write; R = Read only; W1C = Write 1 to clear (writing 0 has no effect); -n = value after reset

Table 35. EMIF Interrupt Mask Register (EIMR) Field Descriptions

Bit	Field	Value	Description
31-3	Reserved	0	Reserved. The reserved bit location is always read as 0. If writing to this field, always write the default value of 0.
2	WRM	0 1	Wait Rise Masked. This bit is set to 1 by hardware to indicate a rising edge has occurred on the EM_WAIT pin, provided that the WRMSET bit is set to 1 in the EMIF interrupt mask set register (EIMSR). 0 Indicates that a wait rise interrupt has not been generated. Writing a 0 has no effect. 1 Indicates that a wait rise interrupt has been generated. Writing a 1 will clear this bit and the WR bit in the EMIF interrupt mask register (EIMR).
1	Reserved	0	Reserved. The reserved bit location is always read as 0. If writing to this field, always write the default value of 0.
0	ATM	0 1	Asynchronous Timeout Masked. This bit is set to 1 by hardware to indicate that during an extended asynchronous memory access cycle the EM_WAIT pin did not go inactive within the number of cycles defined by the MEWC field in the asynchronous wait cycle configuration register (AWCCR), provided that the ATMSET bit is set to 1 in the EMIF interrupt mask set register (EIMSR). 0 Indicates that an asynchronous timeout interrupt has not been generated. Writing a 0 has no effect. 1 Indicates that an asynchronous timeout interrupt has been generated. Writing a 1 will clear this bit and the AT bit in the EMIF interrupt mask register (EIMR).

4.5 EMIF Interrupt Mask Set Register (EIMSR)

The EMIF interrupt mask set register (EIMSR) is used to enable the interrupts. If a bit is set to 1, the corresponding bit in the EMIF interrupt masked register (EIMR) will be set and an interrupt will be generated when the associated interrupt condition occurs. If a bit is cleared to 0, the corresponding bit in EIMR will always read 0 and no interrupts will be generated when the associated interrupt condition occurs. Writing a 1 to the WRMSET and ATMSET bits enables each respective interrupt. The EIMSR is shown in Figure 27 and described in Table 36.

Figure 27. EMIF Interrupt Mask Set Register (EIMSR)

31	Reserved	16	
	R-0		
15	3	2	
1	0		
Reserved	WRMSET	Reserved	ATMSET
R-0	R/W-0	R-0	R/W-0

LEGEND: R/W = Read/Write; R = Read only; -n = value after reset

Table 36. EMIF Interrupt Mask Set Register (EIMSR) Field Descriptions

Bit	Field	Value	Description
31-3	Reserved	0	Reserved. The reserved bit location is always read as 0. If writing to this field, always write the default value of 0.
2	WRMSET	0 1	Wait Rise Mask Set. This bit determines whether or not the wait rise Interrupt is enabled. Writing a 1 to this bit sets this bit, sets the WRMCLR bit in the EMIF interrupt mask clear register (EIMCR), and enables the wait rise interrupt. To clear this bit, a 1 must be written to the WRMCLR bit in EIMCR. 0 Indicates that the wait rise interrupt is disabled. Writing a 0 has no effect. 1 Indicates that the wait rise interrupt is enabled. Writing a 1 sets this bit and the WRMCLR bit in the EMIF interrupt mask clear register (EIMCR).
1	Reserved	0	Reserved. The reserved bit location is always read as 0. If writing to this field, always write the default value of 0.
0	ATMSET	0 1	Asynchronous Timeout Mask Set. This bit determines whether or not the asynchronous timeout interrupt is enabled. Writing a 1 to this bit sets this bit, sets the ATMCLR bit in the EMIF interrupt mask clear register (EIMCR), and enables the asynchronous timeout interrupt. To clear this bit, a 1 must be written to the ATMCLR bit in EIMCR. 0 Indicates that the asynchronous timeout interrupt is disabled. Writing a 0 has no effect. 1 Indicates that the asynchronous timeout interrupt is enabled. Writing a 1 sets this bit and the ATMCLR bit in the EMIF interrupt mask clear register (EIMCR).

4.6 EMIF Interrupt Mask Clear Register (EIMCR)

The EMIF interrupt mask clear register (EIMCR) is used to disable the interrupts. If a bit is read as 1, the corresponding bit in the EMIF interrupt masked register (EIMR) will be set and an interrupt will be generated when the associated interrupt condition occurs. If a bit is read as 0, the corresponding bit in EIMR will always read 0 and no interrupt will be generated when the corresponding interrupt condition occurs. Writing a 1 to the ATMCLR and WRMCLR bits disables each respective interrupt. The EIMCR is shown in Figure 28 and described in Table 37.

Figure 28. EMIF Interrupt Mask Clear Register (EIMCR)

31	Reserved				16	
R-0						
15	Reserved		3	2	1	0
R-0			WRMCLR	Reserved	ATMCLR	
R-0			R/W-0	R-0	R/W-0	

LEGEND: R/W = Read/Write; R = Read only; -n = value after reset

Table 37. EMIF Interrupt Mask Clear Register (EIMCR) Field Descriptions

Bit	Field	Value	Description
31-3	Reserved	0	Reserved. The reserved bit location is always read as 0. If writing to this field, always write the default value of 0.
2	WRMCLR	0 1	Wait Rise Mask Clear. This bit determines whether or not the wait rise interrupt is enabled. Writing a 1 to this bit clears this bit, clears the WRMSET bit in the EMIF interrupt mask set register (EIMSR), and disables the wait rise interrupt. To set this bit, a 1 must be written to the WRMSET bit in EIMSR. 0 Indicates that the wait rise interrupt is disabled. Writing a 0 has no effect. 1 Indicates that the wait rise interrupt is enabled. Writing a 1 clears this bit and the WRMSET bit in the EMIF interrupt mask set register (EIMSR).
1	Reserved	0	Reserved. The reserved bit location is always read as 0. If writing to this field, always write the default value of 0.
0	ATMCLR	0 1	Asynchronous Timeout Mask Clear. This bit determines whether or not the asynchronous timeout interrupt is enabled. Writing a 1 to this bit clears this bit, clears the ATMSET bit in the EMIF interrupt mask set register (EIMSR), and disables the asynchronous timeout interrupt. To set this bit, a 1 must be written to the ATMSET bit in EIMSR. 0 Indicates that the asynchronous timeout interrupt is disabled. Writing a 0 has no effect. 1 Indicates that the asynchronous timeout interrupt is enabled. Writing a 1 clears this bit and the ATMSET bit in the EMIF interrupt mask set register (EIMSR).

4.7 OneNAND Flash Control Register (ONENANDCTL)

The OneNAND flash control register (ONENANDCTL) is shown in Figure 29 and described in Table 38.

Figure 29. OneNAND Flash Control Register (ONENANDCTL)

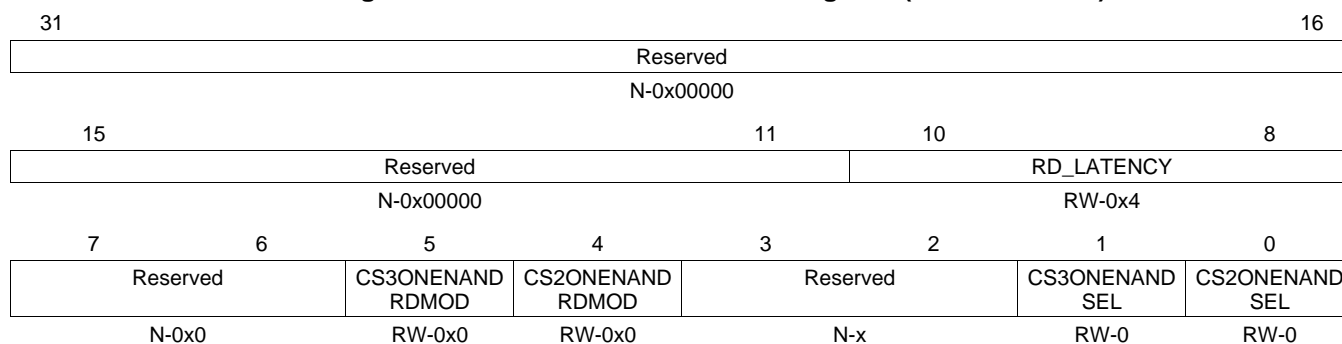

LEGEND: R/W = Read/Write; R = Read only; -n = value after reset

Table 38. OneNAND Flash Control Register (ONENANDCTL) Field Descriptions

Bit	Field	Value	Description
31-11	Reserved	0	Reserved
10-8	RD_LATENCY	0-7h	Synchronous Mode Read Latency. Set to the required read latency value. For example, if OneNAND needs to operate with read latency of 6, program this field to 0x6.
7-6	Reserved	0	Reserved
5	CS3ONENANDR DMOD	0 1	CS3 One NAND Read Mode. Set to 1 if using OneNAND Flash synchronous read mode on CS3. 0 Async mode OneNAND operation 1 Sync mode OneNAND operation
4	CS2ONENANDR DMOD	0 1	CS2 One NAND Read Mode. Set to 1 if using OneNAND Flash synchronous read mode on CS2. 0 Async mode OneNAND operation 1 Sync mode OneNAND operation
3-2	Reserved	0	Reserved
1	CS3ONENANDS EL	0 1	CS3 used for ONENAND mode operation. Set to 1 if using OneNAND Flash on CS3. 0 Do not enable OneNAND mode on chip select 1 Enable OneNAND mode on chip select
0	CS2ONENANDS EL	0 1	CS2 used for ONENAND mode operation. Set to 1 if using OneNAND Flash on CS2. 0 Do not enable OneNAND mode on chip select 1 Enable OneNAND mode on chip select

4.8 NAND Flash Control Register (NANDFCR)

The NAND flash control register (NANDFCR) is shown in [Figure 30](#) and described in [Table 39](#).

Figure 30. NAND Flash Control Register (NANDFCR)

31	Reserved										16
-0											
15	14	13	12	11	10	9	8				
Reserved		4BITECC_ADD_CALC_START	4BITECC_START	Reserved		CS3ECC	CS2ECC				
-0		RW-0	RW-0	-0		RW-0	RW-0				
7	6	5	4	3	2	1	0				
Reserved		4BITECCSEL		Reserved		CS3NAND	CS2NAND				
-0		RW-0		-0		RW-0	RW-0				

LEGEND: R/W = Read/Write; R = Read only; -n = value after reset

Table 39. NAND Flash Control Register (NANDFCR) Field Descriptions

Bit	Field	Value	Description
31-14	Reserved	0	Reserved
13	4BITECC_ADD_CALC_START	0 1	NAND Flash 4-bit ECC address and error value calculation Start. Set to 1 to start 4_bit ECC error address and error value calculation on read syndrome. This bit is cleared when any of the NAND Flash Error Address registers or NAND Flash Error Value registers are read. Begins 4-bit ECC Address and Value Calculation
12	4BITECC_START	0 1	Nand Flash 4-bit ECC start for the selected chip select. Set to 1 to start 4_bit ECC calculation on data for NAND Flash on chip select selected by bit 4BITECCSEL. This bit is cleared when ay of the NAND Flash 4_bit ECC registers are read. Begins 4-bit ECC Calculation
11-10	Reserved	0	Reserved
9	CS3ECC	0 1	NAND Flash 1_bit ECC start for chip select 3. Set to 1 to start 1_bit ECC calculation on data for NAND Flash for this chip select. This bit is cleared when CS3 1_bit EEC register is read. Do not start ECC calculation on chip select Start 1_bit ECC calculation on chip select
8	CS2ECC	0 1	NAND Flash ECC start for chip select 2. Set to 1 to start 1_bit ECC calculation on data for NAND Flash for this chip select. This bit is cleared when CS2 1_bit EEC register is read. Do not start ECC calculation on chip select Start ECC calculation on chip select
7-6	Reserved	0	Reserved
5-4	4BITECCSEL	0 1	4Bit ECC CS selection. This field selects the chip select on which the 4_bit ECC will be calculated. Select the CS2 for the 4bit ECC calculation Select the CS3 for the 4bit ECC calculation
3-2	Reserved	0	Reserved
1	CS3NAND	0 1	NAND Flash mode for chip select 3. Do not enable NAND Flash on chip select Enable NAND Flash on chip select
0	CS2NAND	0 1	NAND Flash mode for chip select 2. Do not enable NAND Flash on chip select Enable NAND Flash on chip select

4.9 NAND Flash Status Register (NANDFSR)

The NAND Flash status register (NANDFSR) is shown in [Figure 31](#) and described in [Table 40](#).

Figure 31. NAND Flash Status Register (NANDFSR)

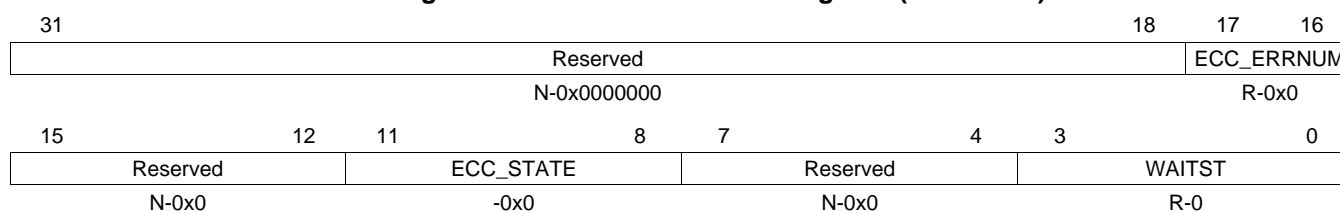

LEGEND: R/W = Read/Write; R = Read only; -n = value after reset

Table 40. NAND Flash Status Register (NANDFSR) Field Descriptions

Bit	Field	Value	Description
31-18	Reserved	0	Reserved
17-16	ECC_ERRNUM	0 1 2 3	Number of Errors found after the 4-Bit ECC Error Address and Error Value Calculation is done 1 error found 2 errors found 3 errors found 4 errors found
15-12	Reserved	0	Reserved
11-8	ECC_STATE	0h 1h 2h 3h 4h 5h 6h - 7h 8h 9h - Bh Ch - Fh	ECC correction state while performing 4-bit ECC Address and Error Value Calculation No errors detected Errors cannot be corrected (5 or more) Error correction complete Error correction complete Reserved Calculating number of errors Preparing for error search Searching for errors Reserved Calculating error value
7-4	Reserved	0	Reserved for future use.
3-0	WAITST	0-Fh	Raw status of the EM_WAIT input pin. Note that the WPO bit in the asynchronous wait cycle configuration register (AWCCR) has no effect on WAITST.

4.10 NAND Flash n ECC Registers (NANDF1ECC-NANDF2ECC)

The NAND Flash n ECC register (NANDF1ECC-NANDF2ECC) is shown in [Figure 32](#) and described in [Table 41](#). For 8-bit NAND Flash, P1O, P2O, and P4O bits are column parities; P8O to P2048O bits are row parities. For 16-bit NAND Flash, P1O, P2O, P4O, and P8O bits are column parities; P16O to P2048O bits are row parities.

Figure 32. NAND Flash n ECC Register (NANDFnECC)

31				28	27	26	25	24
Reserved				P2048O	P1024O	P512O	P256O	
R-0				R-0	R-0	R-0	R-0	
23	22	21	20	19	18	17	16	
P128O	P64O	P32O	P16O	P8O	P4O	P2O	P1O	
R-0	R-0	R-0	R-0	R-0	R-0	R-0	R-0	
15				12	11	10	9	8
Reserved				P2048E	P1024E	P512E	P256E	
R-0				R-0	R-0	R-0	R-0	
7	6	5	4	3	2	1	0	
P128E	P64E	P32E	P16E	P8E	P4E	P2E	P1E	
R-0	R-0	R-0	R-0	R-0	R-0	R-0	R-0	

LEGEND: R = Read only; -n = value after reset

Table 41. NAND Flash n ECC Register (NANDFnECC) Field Descriptions

Bit	Field	Value	Description
31-28	Reserved	0	Reserved
27	P2048O	0-1	ECC code calculated while reading/writing NAND Flash.
26	P1024O	0-1	ECC code calculated while reading/writing NAND Flash.
25	P512O	0-1	ECC code calculated while reading/writing NAND Flash.
24	P256O	0-1	ECC code calculated while reading/writing NAND Flash.
23	P128O	0-1	ECC code calculated while reading/writing NAND Flash.
22	P64O	0-1	ECC code calculated while reading/writing NAND Flash.
21	P32O	0-1	ECC code calculated while reading/writing NAND Flash.
20	P16O	0-1	ECC code calculated while reading/writing NAND Flash.
19	P8O	0-1	ECC code calculated while reading/writing NAND Flash.
18	P4O	0-1	ECC code calculated while reading/writing NAND Flash.
17	P2O	0-1	ECC code calculated while reading/writing NAND Flash.
16	P1O	0-1	ECC code calculated while reading/writing NAND Flash.
15-12	Reserved	0	Reserved
11	P2948E	0-1	ECC code calculated while reading/writing NAND Flash.
10	P102E	0-1	ECC code calculated while reading/writing NAND Flash.
9	P512E	0-1	ECC code calculated while reading/writing NAND Flash.
8	P256E	0-1	ECC code calculated while reading/writing NAND Flash.
7	P128E	0-1	ECC code calculated while reading/writing NAND Flash.
6	P64E	0-1	ECC code calculated while reading/writing NAND Flash.
5	P32E	0-1	ECC code calculated while reading/writing NAND Flash.
4	P15E	0-1	ECC code calculated while reading/writing NAND Flash.
3	P8E	0-1	ECC code calculated while reading/writing NAND Flash.
2	P4E	0-1	ECC code calculated while reading/writing NAND Flash.
1	P2E	0-1	ECC code calculated while reading/writing NAND Flash.
0	P1E	0-1	ECC code calculated while reading/writing NAND Flash.

4.11 NAND Flash 4-bit ECC LOAD Register (NAND4BITECCLOAD)

The NAND Flash 4-bit ECC load register (NAND4BITECCLOAD) is shown in [Figure 33](#) and described in [Table 42](#).

Figure 33. NAND Flash 4-bit ECC LOAD Register (NAND4BITECCLOAD)

31	Reserved	10 9	4BITECCLOAD	0
	N-0x0		RW-0x000	

LEGEND: R/W = Read/Write; R = Read only; -n = value after reset

Table 42. NAND Flash 4-bit ECC LOAD Register (NAND4BITECCLOAD) Field Descriptions

Bit	Field	Value	Description
31-10	Reserved	0	Reserved
9-0	4BITECCLOAD	0-3FFh	4-bit ECC load. This register is used to load the ECC values when performing the Syndrome calculation during reads

4.12 NAND Flash 4-bit ECC Register 1 (NAND4BITECC1)

The NAND Flash 4-bit ECC register 1 (NAND4BITECC1) is shown in [Figure 34](#) and described in [Table 43](#).

Figure 34. NAND Flash 4-bit ECC1 Register (NAND4BITECC1)

31	Reserved	26 25	4BITECCVAL2	16 15	Reserved	10 9	4BITECCVAL1	0
	N-0x0		RW-0x000		N-0x0		RW-0x000	

LEGEND: R/W = Read/Write; R = Read only; -n = value after reset

Table 43. NAND Flash 4-bit ECC Register 1 (NAND4BITECC1) Field Descriptions

Bit	Field	Value	Description
31-26	Reserved	0	Reserved
25-16	4BITECCVAL2	0-3FFh	Calculated 4-bit ECC or Syndrom Value2
15-10	Reserved	0	Reserved
9-0	4BITECCVAL1	0-3FFh	Calculated 4-bit ECC or Syndrom Value1

4.13 NAND Flash 4-bit ECC Register 2 (NAND4BITECC2)

The NAND Flash 4-bit ECC register 2 (NAND4BITECC2) is shown in [Figure 35](#) and described in [Table 44](#).

Figure 35. NAND Flash 4-bit ECC2 Register (NAND4BITECC2)

31	26	25	16	15	10	9	0
Reserved	4BITECCVAL4		Reserved		4BITECCVAL3		
N-0x0	RW-0x000		N-0x0		RW-0x000		

LEGEND: R/W = Read/Write; R = Read only; -n = value after reset

Table 44. NAND Flash 4-bit ECC2 Register (NAND4BITECC2) Field Descriptions

Bit	Field	Value	Description
31-26	Reserved	0	Reserved
25-16	4BITECCVAL4	0-3FFh	Calculated 4-bit ECC or Syndrom Value4
15-10	Reserved	0	Reserved
9-0	4BITECCVAL3	0-3FFh	Calculated 4-bit ECC or Syndrom Value3

4.14 NAND Flash 4-bit ECC Register 3 (NAND4BITECC3)

The NAND Flash 4-bit ECC register 3 (NAND4BITECC3) is shown in [Figure 36](#) and described in [Table 45](#).

Figure 36. NAND Flash 4-bit ECC3 Register (NAND4BITECC3)

31	26	25	16	15	10	9	0
Reserved	4BITECCVAL6		Reserved		4BITECCVAL5		
N-0x0	RW-0x000		N-0x0		RW-0x000		

LEGEND: R/W = Read/Write; R = Read only; -n = value after reset

Table 45. NAND Flash 4-bit ECC Register 3 (NAND4BITECC3) Field Descriptions

Bit	Field	Value	Description
31-26	Reserved	0	Reserved
25-16	4BITECCVAL6	0-3FFh	Calculated 4-bit ECC or Syndrom Value6
15-10	Reserved	0	Reserved
9-0	4BITECCVAL5	0-3FFh	Calculated 4-bit ECC or Syndrom Value5

4.15 NAND Flash 4-bit ECC Register 4 (NAND4BITECC4)

The NAND Flash 4-bit ECC register 4 (NAND4BITECC4) is shown in [Figure 37](#) and described in [Table 46](#).

Figure 37. NAND Flash 4-bit ECC Register 4 (NAND4BITECC4)

31	26	25	16	15	10	9	0
Reserved		4BITECCVAL8		Reserved		4BITECCVAL7	
N-0x0		RW-0x000		N-0x0		RW-0x000	

LEGEND: R/W = Read/Write; R = Read only; -n = value after reset

Table 46. NAND Flash 4-bit ECC Register 4 (NAND4BITECC4) Field Descriptions

Bit	Field	Value	Description
31-26	Reserved	0	Reserved
25-16	4BITECCVAL8	0-3FFh	Calculated 4-bit ECC or Syndrom Value8
15-10	Reserved	0	Reserved
9-0	4BITECCVAL7	0-3FFh	Calculated 4-bit ECC or Syndrom Value7

4.16 NAND Flash 4-bit ECC Error Address Register 1 (NANDERRADD1)

The NAND Flash 4-bit ECC error register 1 (NANDERRADD1) is shown in [Figure 38](#) and described in [Table 47](#).

Figure 38. NAND Flash 4-bit ECC Error Address Register 1 (NANDERRADD1)

31	26	25	16	15	10	9	0
Reserved		4BITECCERRADD2		Reserved		4BITECCERRADD1	
N-0x0		RW-0x000		N-0x0		RW-0x000	

LEGEND: R/W = Read/Write; R = Read only; -n = value after reset

Table 47. NAND Flash 4-bit ECC Error Address Register 1 (NANDERRADD1) Field Descriptions

Bit	Field	Value	Description
31-26	Reserved	0	Reserved
25-16	4BITECCERRAD D2	0-3FFh	Calculated 4-bit ECC Error Address 2
15-10	Reserved	0	Reserved
9-0	4BITECCERRAD D1	0-3FFh	Calculated 4-bit ECC Error Address 1

4.17 NAND Flash 4-bit ECC Error Address Register 2 (NANDERRADD2)

The NAND Flash 4-bit ECC error register 2 (NANDERRADD2) is shown in [Figure 39](#) and described in [Table 48](#).

Figure 39. NAND Flash 4-bit ECC Error Address Register 2 (NANDERRADD2)

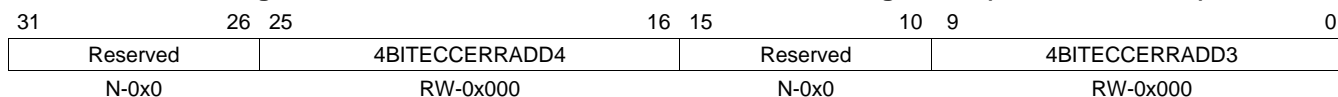

LEGEND: R/W = Read/Write; R = Read only; -n = value after reset

Table 48. NAND Flash 4-bit ECC Error Address Register 2 (NANDERRADD2) Field Descriptions

Bit	Field	Value	Description
31-26	Reserved	0	Reserved
25-16	4BITECCERRADD4	0-3FFh	Calculated 4-bit ECC Error Address 4
15-10	Reserved	0	Reserved
9-0	4BITECCERRADD3	0-3FFh	Calculated 4-bit ECC Error Address 3

4.18 NAND Flash 4-bit ECC Error Value Register 1 (NANDERRVAL1)

The NAND Flash 4-bit ECC error value register 1 (NANDERRVAL1) is shown in [Figure 40](#) and described in [Table 49](#).

Figure 40. NAND Flash 4-bit ECC Error Value Register 1 (NANDERRVAL1)

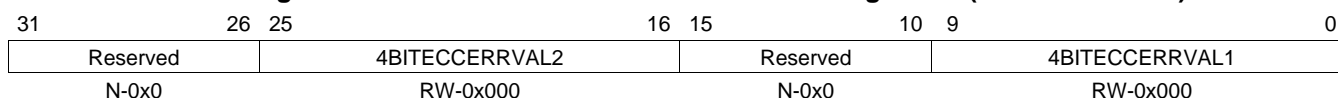

LEGEND: R/W = Read/Write; R = Read only; -n = value after reset

Table 49. NAND Flash 4-bit ECC Error Value Register 1 (NANDERRVAL1) Field Descriptions

Bit	Field	Value	Description
31-26	Reserved	0	Reserved
25-16	4BITECCERRVAL2	0-3FFh	Calculated 4-bit ECC Error Value 2
15-10	Reserved	0	Reserved
9-0	4BITECCERRVAL1	0-3FFh	Calculated 4-bit ECC Error Value 1

4.19 NAND Flash 4-bit ECC Error Value Register 2 (NANDERRVAL2)

The NAND Flash 4-bit ECC error value register 2 (NANDERRVAL2) is shown in [Figure 41](#) and described in [Table 50](#).

Figure 41. NAND Flash 4-bit ECC Error Value Register 2 (NANDERRVAL2)

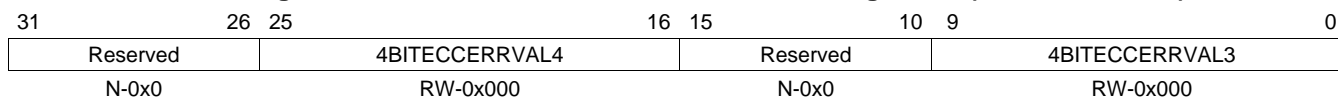

LEGEND: R/W = Read/Write; R = Read only; -n = value after reset

Table 50. NAND Flash 4-bit ECC Error Value Register 2 (NANDERRVAL2) Field Descriptions

Bit	Field	Value	Description
31-26	Reserved	0	Reserved
25-16	4BITECCERRVA L4	0-3FFh	Calculated 4-bit ECC Error Value 4
15-10	Reserved	0	Reserved
9-0	4BITECCERRVA L3	0-3FFh	Calculated 4-bit ECC Error Value 3

5 Revision History

This document has been revised to include the following technical change to SPRUF1B to make it a C revision.

Table 51. Document Revision History

Reference	Additions/Modifications/Deletions
Global	Changed EM_CE[1:0] to EM_CE[3:2].

IMPORTANT NOTICE

Texas Instruments Incorporated and its subsidiaries (TI) reserve the right to make corrections, modifications, enhancements, improvements, and other changes to its products and services at any time and to discontinue any product or service without notice. Customers should obtain the latest relevant information before placing orders and should verify that such information is current and complete. All products are sold subject to TI's terms and conditions of sale supplied at the time of order acknowledgment.

TI warrants performance of its hardware products to the specifications applicable at the time of sale in accordance with TI's standard warranty. Testing and other quality control techniques are used to the extent TI deems necessary to support this warranty. Except where mandated by government requirements, testing of all parameters of each product is not necessarily performed.

TI assumes no liability for applications assistance or customer product design. Customers are responsible for their products and applications using TI components. To minimize the risks associated with customer products and applications, customers should provide adequate design and operating safeguards.

TI does not warrant or represent that any license, either express or implied, is granted under any TI patent right, copyright, mask work right, or other TI intellectual property right relating to any combination, machine, or process in which TI products or services are used. Information published by TI regarding third-party products or services does not constitute a license from TI to use such products or services or a warranty or endorsement thereof. Use of such information may require a license from a third party under the patents or other intellectual property of the third party, or a license from TI under the patents or other intellectual property of TI.

Reproduction of TI information in TI data books or data sheets is permissible only if reproduction is without alteration and is accompanied by all associated warranties, conditions, limitations, and notices. Reproduction of this information with alteration is an unfair and deceptive business practice. TI is not responsible or liable for such altered documentation. Information of third parties may be subject to additional restrictions.

Resale of TI products or services with statements different from or beyond the parameters stated by TI for that product or service voids all express and any implied warranties for the associated TI product or service and is an unfair and deceptive business practice. TI is not responsible or liable for any such statements.

TI products are not authorized for use in safety-critical applications (such as life support) where a failure of the TI product would reasonably be expected to cause severe personal injury or death, unless officers of the parties have executed an agreement specifically governing such use. Buyers represent that they have all necessary expertise in the safety and regulatory ramifications of their applications, and acknowledge and agree that they are solely responsible for all legal, regulatory and safety-related requirements concerning their products and any use of TI products in such safety-critical applications, notwithstanding any applications-related information or support that may be provided by TI. Further, Buyers must fully indemnify TI and its representatives against any damages arising out of the use of TI products in such safety-critical applications.

TI products are neither designed nor intended for use in military/aerospace applications or environments unless the TI products are specifically designated by TI as military-grade or "enhanced plastic." Only products designated by TI as military-grade meet military specifications. Buyers acknowledge and agree that any such use of TI products which TI has not designated as military-grade is solely at the Buyer's risk, and that they are solely responsible for compliance with all legal and regulatory requirements in connection with such use.

TI products are neither designed nor intended for use in automotive applications or environments unless the specific TI products are designated by TI as compliant with ISO/TS 16949 requirements. Buyers acknowledge and agree that, if they use any non-designated products in automotive applications, TI will not be responsible for any failure to meet such requirements.

Following are URLs where you can obtain information on other Texas Instruments products and application solutions:

Products		Applications	
Amplifiers	amplifier.ti.com	Audio	www.ti.com/audio
Data Converters	dataconverter.ti.com	Automotive	www.ti.com/automotive
DLP® Products	www.dlp.com	Communications and Telecom	www.ti.com/communications
DSP	dsp.ti.com	Computers and Peripherals	www.ti.com/computers
Clocks and Timers	www.ti.com/clocks	Consumer Electronics	www.ti.com/consumer-apps
Interface	interface.ti.com	Energy	www.ti.com/energy
Logic	logic.ti.com	Industrial	www.ti.com/industrial
Power Mgmt	power.ti.com	Medical	www.ti.com/medical
Microcontrollers	microcontroller.ti.com	Security	www.ti.com/security
RFID	www.ti-rfid.com	Space, Avionics & Defense	www.ti.com/space-avionics-defense
RF/IF and ZigBee® Solutions	www.ti.com/lprf	Video and Imaging	www.ti.com/video
		Wireless	www.ti.com/wireless-apps

Mailing Address: Texas Instruments, Post Office Box 655303, Dallas, Texas 75265
Copyright © 2010, Texas Instruments Incorporated