

TMS320C6474 DSP Multichannel Buffered Serial Port (McBSP)

User's Guide



Literature Number: SPRUG17A
October 2008–Revised May 2010

| | |
|--|-----------|
| Preface | 8 |
| 1 Features | 9 |
| 2 McBSP Interface | 10 |
| 3 McBSP Overview | 12 |
| 3.1 Resetting the Serial Port: RRST, XRST, GRST, and RESET | 12 |
| 3.2 Determining Ready Status | 13 |
| 3.3 CPU Interrupts: RINT, XINT | 13 |
| 3.4 Frame and Clock Configuration | 14 |
| 4 Clocks, Frames, and Data | 15 |
| 4.1 Frame and Clock Operation | 16 |
| 4.2 Sample Rate Generator Clocking and Framing | 17 |
| 4.3 Data Clock Generation | 18 |
| 4.4 Frame Sync Generation | 22 |
| 4.5 Data and Frames | 24 |
| 4.6 Clocking and Framing Examples | 28 |
| 5 McBSP Standard Operation | 33 |
| 5.1 Receive Operation | 33 |
| 5.2 Transmit Operation | 34 |
| 5.3 Maximum Frame Frequency | 34 |
| 5.4 Frame Synchronization Ignore | 35 |
| 5.5 Serial Port Exception Conditions | 38 |
| 6 μ-Law/A-Law Companding Hardware Operation | 44 |
| 6.1 Companding Internal Data | 45 |
| 6.2 Bit Ordering | 45 |
| 7 McBSP Initialization Procedure | 46 |
| 7.1 General Initialization Procedure | 46 |
| 7.2 Special Case: External Device is the Transmit Frame Master | 48 |
| 8 Multichannel Selection Operation | 50 |
| 8.1 Enabling Multichannel Selection | 50 |
| 8.2 Enabling and Masking of Channels in Normal Multichannel Selection Mode | 50 |
| 8.3 Changing Element Selection | 53 |
| 8.4 End-of-Subframe Interrupt | 53 |
| 8.5 Enhanced Multichannel Selection Mode | 53 |
| 8.6 DX Enabler: DXENA | 55 |
| 9 SPI Protocol: CLKSTP | 56 |
| 9.1 McBSP Operation as the SPI Master | 58 |
| 9.2 McBSP Operation as the SPI Slave | 58 |
| 9.3 McBSP Initialization for SPI Mode | 59 |
| 10 McBSP Pins as General-Purpose I/O | 60 |
| 11 McBSP Registers | 61 |
| 11.1 Data Receive Register (DRR) | 62 |
| 11.2 Data Transmit Register (DXR) | 63 |

| | | |
|--|---|-----------|
| 11.3 | Serial Port Control Register (SPCR) | 64 |
| 11.4 | Receive Control Register (RCR) | 67 |
| 11.5 | Transmit Control Register (XCR) | 74 |
| 11.6 | Sample Rate Generator Register (SRGR) | 81 |
| 11.7 | Multichannel Control Register (MCR) | 82 |
| 11.8 | Receive Channel Enable Register (RCER) | 84 |
| 11.9 | Transmit Channel Enable Registers (XCER) | 85 |
| 11.10 | Enhanced Receive Channel Enable Registers (RCERE0-3) | 86 |
| 11.11 | Enhanced Transmit Channel Enable Registers (XCERE0-3) | 89 |
| 11.12 | Pin Control Register (PCR) | 95 |
| Appendix A Revision History | | 97 |

List of Figures

| | | |
|----|---|----|
| 1 | McBSP Block Diagram..... | 10 |
| 2 | Frame and Clock Operation..... | 14 |
| 3 | Clock and Frame Generation | 15 |
| 4 | Receive Data Clocking..... | 16 |
| 5 | Transmit Data Clocking..... | 16 |
| 6 | Sample Rate Generator | 17 |
| 7 | CLKG Synchronization and FSG Generation When GSYNC = 1 and CLKGDV = 1 | 19 |
| 8 | CLKG Synchronization and FSG Generation When GSYNC = 1 and CLKGDV = 3 | 20 |
| 9 | Programmable Frame Period and Width | 22 |
| 10 | Dual-Phase Frame Example | 24 |
| 11 | Single-Phase Frame and Four 8-Bit Elements | 26 |
| 12 | Single-Phase Frame of One 32-Bit Element | 26 |
| 13 | Data Delay..... | 27 |
| 14 | Bit Data Delay Used to Discard Framing Bit..... | 27 |
| 15 | AC97 Dual-Phase Frame Format | 29 |
| 16 | AC97 Bit Timing Near Frame Synchronization | 29 |
| 17 | McBSP to ST-BUS Block Diagram | 30 |
| 18 | Double-Rate ST-BUS Clock Example | 30 |
| 19 | Single-Rate ST-BUS Clock Example | 31 |
| 20 | Double-Rate Clock Example | 32 |
| 21 | McBSP Standard Operation..... | 33 |
| 22 | Receive Operation..... | 33 |
| 23 | Transmit Operation..... | 34 |
| 24 | Maximum Frame Frequency for Transmit and Receive | 34 |
| 25 | Unexpected Frame Synchronization With (R/X) FIG = 0 | 35 |
| 26 | Unexpected Frame Synchronization With (R/X)FIG = 1 | 36 |
| 27 | Maximum Frame Frequency Operation with 8-Bit Data | 37 |
| 28 | Data Packing at Maximum Frame Frequency With (R/X)FIG = 1..... | 38 |
| 29 | Serial Port Overrun..... | 39 |
| 30 | Serial Port Receive Overrun Avoided..... | 39 |
| 31 | Decision Tree Response to Receive Frame Synchronization Pulse..... | 40 |
| 32 | Unexpected Receive Synchronization Pulse | 40 |
| 33 | Transmit With Data Overwrite | 41 |
| 34 | Transmit Empty | 42 |
| 35 | Transmit Empty Avoided | 42 |
| 36 | Decision Tree Response to Transmit Frame Synchronization Pulse..... | 43 |
| 37 | Unexpected Transmit Frame Synchronization Pulse | 43 |
| 38 | Companding Flow | 44 |
| 39 | Companding Data Formats | 44 |
| 40 | Transmit Data Companding Format in DXR | 44 |
| 41 | Companding of Internal Data | 45 |
| 42 | Element Enabling by Subframes in Partitions A and B..... | 51 |
| 43 | XMCM = 00b FOR XMCM Operation | 52 |
| 44 | XMCM = 01b, XPABLK = 00b, XCER = 1010b for XMCM Operation..... | 52 |
| 45 | XMCM = 10b, XPABLK = 00b, XCER = 1010b for XMCM Operation | 52 |
| 46 | XMCM = 11b, RPABLK = 00b, XPABLK = X, RCER = 1010b, XCER = 1000b for XMCM Operation | 53 |
| 47 | DX Timing for Multichannel Operation..... | 55 |

| | | |
|----|---|----|
| 48 | SPI Configuration: McBSP as the Master | 56 |
| 49 | Configuration: McBSP as the Slave..... | 56 |
| 50 | SPI Transfer with CLKSTP = 10b | 57 |
| 51 | SPI Transfer with CLKSTP = 11b | 57 |
| 52 | Data Receive Register (DRR) | 62 |
| 53 | Data Transmit Register (DXR) | 63 |
| 54 | Serial Port Control Register (SPCR) | 64 |
| 55 | Receive Control Register (RCR) | 67 |
| 56 | Transmit Control Register (XCR) | 74 |
| 57 | Sample Rate Generator Register (SRGR) | 81 |
| 58 | Multichannel Control Register (MCR) | 82 |
| 59 | Receive Channel Enable Register (RCER) | 84 |
| 60 | Transmit Channel Enable Registers (XCER) | 85 |
| 61 | Format of the Enhanced Receive Channel Enable Registers (RCERE0-3) | 86 |
| 62 | Format of the Enhanced Transmit Channel Enable Registers (XCERE0-3) | 89 |
| 63 | Pin Control Register (PCR) | 95 |

List of Tables

| | | |
|----|--|----|
| 1 | McBSP Interface Pins..... | 11 |
| 2 | Reset State of McBSP Pins | 12 |
| 3 | Receive Clock Selection | 21 |
| 4 | Transmit Clock Selection | 21 |
| 5 | Receive Frame Synchronization Selection..... | 23 |
| 6 | Transmit Frame Synchronization Selection | 23 |
| 7 | RCR/XCR Fields Controlling Elements per Frame and Bits per Element..... | 24 |
| 8 | Receive/Transmit Frame Length Configuration | 25 |
| 9 | Receive/Transmit Element Length Configuration | 25 |
| 10 | Effect of RJUST Bit Values With 12-Bit Example Data ABCh..... | 28 |
| 11 | Effect of RJUST Bit Values With 20-Bit Example Data ABCDEh | 28 |
| 12 | Justification of Expanded Data in DRR | 44 |
| 13 | Receiver Clock and Frame Configurations..... | 46 |
| 14 | Transmitter Clock and Frame Configurations..... | 46 |
| 15 | Configuration of Pins as General Purpose I/O | 60 |
| 16 | McBSP Registers | 61 |
| 17 | Data Receive Register (DRR) Field Descriptions | 62 |
| 18 | Data Transmit Register (DXR) Field Descriptions | 63 |
| 19 | Serial Port Control Register (SPCR) Field Descriptions..... | 64 |
| 20 | Receive Control Register (RCR) Field Descriptions | 67 |
| 21 | Transmit Control Register (XCR) Field Descriptions | 74 |
| 22 | Sample Rate Generator Register (SRGR) Field Descriptions | 81 |
| 23 | Multichannel Control Register (MCR) Field Descriptions | 82 |
| 24 | Receive Channel Enable Register (RCER) Field Descriptions..... | 84 |
| 25 | Transmit Channel Enable Register (XCER) Field Descriptions | 85 |
| 26 | Format of the Enhanced Receive Channel Enable Registers (RCERE0-3) Field Descriptions..... | 86 |
| 27 | Use of the Enhanced Receive Channel Enable Registers..... | 87 |
| 28 | Description for Bit x of a Transmit Channel Enable Register (XCERE0-3) Field Descriptions..... | 89 |
| 29 | Use of the Enhanced Transmit Channel Enable Registers | 90 |
| 30 | Pin Control Register (PCR) Field Descriptions | 95 |
| 31 | McBSP Revision History..... | 97 |

Read This First

About This Manual

This document describes the operation of the multichannel buffered serial port (McBSP) in the TMS320C6474 digital signal processors (DSPs) of the TMS320C6000™ DSP family.

Notational Conventions

This document uses the following conventions.

- Hexadecimal numbers are shown with the suffix h. For example, the following number is 40 hexadecimal (decimal 64): 40h.
- Registers in this document are shown in figures and described in tables.
 - Each register figure shows a rectangle divided into fields that represent the fields of the register. Each field is labeled with its bit name, its beginning and ending bit numbers above, and its read/write properties below. A legend explains the notation used for the properties.
 - Reserved bits in a register figure designate a bit that is used for future device expansion.

Related Documentation From Texas Instruments

The following documents describe the C6000™ devices and related support tools. Copies of these documents are available on the Internet at www.ti.com. *Tip:* Enter the literature number in the search box provided at www.ti.com.

[SPRU189](#) — *TMS320C6000 DSP CPU and Instruction Set Reference Guide*. Describes the CPU architecture, pipeline, instruction set, and interrupts for the TMS320C6000 digital signal processors (DSPs).

[SPRU198](#) — *TMS320C6000 Programmer's Guide*. Describes ways to optimize C and assembly code for the TMS320C6000™ DSPs and includes application program examples.

[SPRU301](#) — *TMS320C6000 Code Composer Studio Tutorial*. Introduces the Code Composer Studio™ integrated development environment and software tools.

[SPRU321](#) — *Code Composer Studio Application Programming Interface Reference Guide*. Describes the Code Composer Studio™ application programming interface (API), which allows you to program custom plug-ins for Code Composer.

[SPRU871](#) — *TMS320C64x+ Megamodule Reference Guide*. Describes the TMS320C64x+ digital signal processor (DSP) megamodule. Included is a discussion on the internal direct memory access (IDMA) controller, the interrupt controller, the power-down controller, memory protection, bandwidth management, and the memory and cache.

Multichannel Buffered Serial Port (McBSP)

1 Features

This section provides a list of the McBSP features. The McBSP provides these functions:

- Full-duplex communication
- Double-buffered data registers, which allow a continuous data stream
- Independent framing and clocking for receive and transmit
- Direct interface to industry-standard codecs, analog interface chips (AICs), and other serially connected analog-to-digital (A/D) and digital-to-analog (D/A) devices
- External shift clock or an internal, programmable frequency shift clock for data transfer

In addition, the McBSP has the following capabilities:

- Direct interface to:
 - T1/E1 framers
 - MVIP switching compatible and ST-BUS compliant devices including:
 - MVIP framers
 - H.100 framers
 - SCSA framers
 - IOM-2 compliant devices
 - AC97 compliant devices (The necessary multi phase frame synchronization capability is provided.)
 - IIS compliant devices
 - SPI™ devices
- Multichannel transmit and receive of up to 128 channels
- A wide selection of data sizes, including 8, 12, 16, 20, 24, and 32 bits
- μ -Law and A-Law companding
- 8-bit data transfers with the option of LSB or MSB first
- Programmable polarity for both frame synchronization and data clocks
- Highly programmable internal clock and frame generation

All C6000 devices have the same McBSP. However, the C6474 McBSP has the following additional features and enhancements:

- DX Enabler (DXENA)
- 32-bit data reversal (RWDREVRS/XWDREVRS)
- Enhanced multichannel selection mode (RMCME/XMCME)
- Emulation control (FREE, SOFT)

2 McBSP Interface

The McBSP consists of a data path and a control path that connect to external devices.

The C6000 CPU communicates with the McBSP by reading or writing to its 32-bit-wide control registers. The McBSP consists of a data path and a control path that connect to external devices. Separate pins for transmission and reception communicate data to these external devices. Four other pins communicate control information (clocking and frame synchronization). The C6000 CPU communicates with the McBSP by reading or writing to its 32-bit-wide control registers.

The device communicates to the McBSP using two separate buses (see Figure 1). The CPU accesses the control and data registers via a configuration bus and the EDMA uses its dedicated bus (the EDMA bus) to access the data registers.

The McBSP consists of a data path and control path, as shown in Figure 1. Seven pins, listed in Table 1, connect the control and data paths to external devices.

Figure 1. McBSP Block Diagram

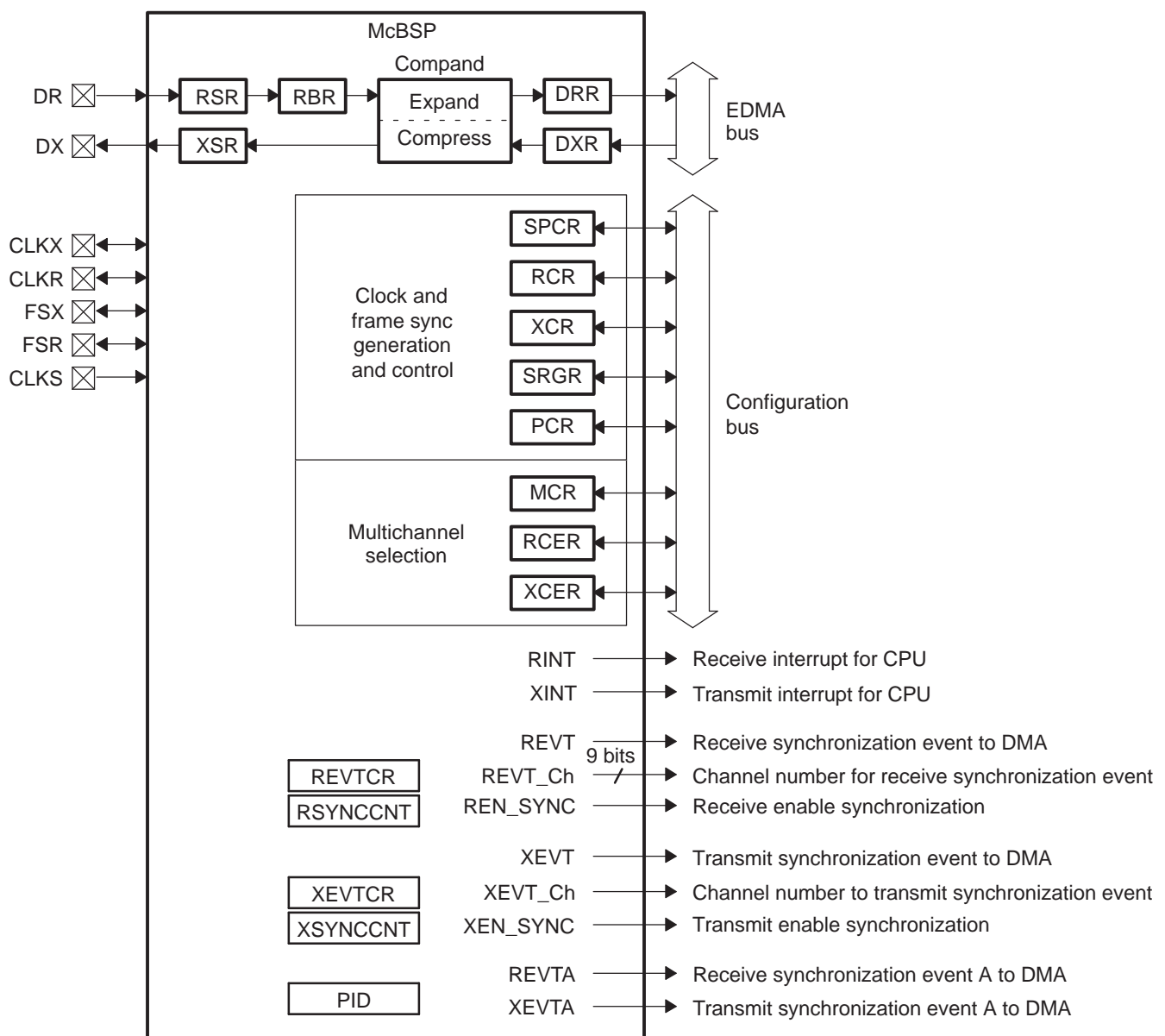

A The CPU accesses the control and data registers via a configuration bus. The EDMA3 controller uses its dedicated bus, the EDMA bus, to access the data registers.

Data is communicated to devices interfacing to the McBSP via the data transmit (DX) pin for transmission and via the data receive (DR) pin for reception. Control information (clocking and frame synchronization) is communicated via CLKS, CLKX, CLKR, FSX, and FSR. The C6000 CPU communicates with the McBSP by reading or writing to its 32-bit-wide control registers. Non-32-bit write accesses to control registers can result in corrupting the control register value. This is because undefined values are written to non-enabled bytes. However, non-32-bit read accesses return the correct value.

Either the CPU or the DMA/EDMA controller reads the received data from the data receive register (DRR) and writes the data to be transmitted to the data transmit register (DXR). Data written to DXR is shifted out to DX via the transmit shift register (XSR). Similarly, receive data on the DR pin is shifted into the receive shift register (RSR) and copied into the receive buffer register (RBR). RBR is then copied to DRR, which can be read by the CPU or the DMA/EDMA controller. This allows simultaneous internal data movement and external data communications. For information on registers, see [Section 11](#).

Table 1. McBSP Interface Pins

| Pin | I/O/Z | Description |
|------|-------|--------------------------------|
| CLKR | I/O/Z | Receive clock |
| CLKX | I/O/Z | Transmit clock |
| CLKS | I | External clock |
| DR | I | Received serial data |
| DX | O/Z | Transmitted serial data |
| FSR | I/O/Z | Receive frame synchronization |
| FSX | I/O/Z | Transmit frame synchronization |

3 McBSP Overview

As shown in [Figure 1](#), the receive operation is triple-buffered and the transmit operation is double-buffered. Receive data arrives on the DR and is shifted into the RSR. Once a full element (8, 12, 16, 20, 24, or 32 bits) is received, the RSR is copied to the receive buffer register (RBR) only if the RBR is not full. The RBR is then copied to DRR unless the DRR has not been read by the CPU or the DMA/EDMA controller.

The CPU or the DMA/EDMA controller writes transmit data to DXR. If there is no data in XSR, the value in DXR is copied to XSR. Otherwise, the DXR is copied to XSR when the last bit of data is shifted out on the DX. After transmit frame synchronization, XSR begins shifting out the transmit data on the DX.

3.1 Resetting the Serial Port: *RRST*, *XRST*, *GRST*, and *RESET*

The serial port can be reset in two ways:

- Device reset ($\overline{\text{RESET}}$ pin is low) places the receiver, the transmitter, and the sample rate generator in reset. If it is removed ($\text{RESET} = 1$), $\text{FRST} = \text{GRST} = \text{RRST} = \text{XRST} = 0$, the entire serial port is kept in the reset state.
- The serial port transmitter and receiver can be independently reset by the *XRST* and *RRST* bits in the serial port control register (SPCR). The sample rate generator is reset by the *GRST* bit in SPCR.

[Table 2](#) shows the state of the McBSP pins when the serial port is reset by these methods.

Table 2. Reset State of McBSP Pins

| Pin | Direction | Device Reset ($\text{RESET} = 0$) | McBSP Reset |
|--|-----------|--|---|
| Receiver Reset ($\text{RRST} = 0$ and $\text{GRST} = 1$) | | | |
| DR | I | Input | Input |
| CLKR | I/O/Z | Input | The CLKRM bit determines if the CLKR pin is input or output; if it is configured as output, the CLKR drives the pin. |
| FSR | I/O/Z | Input | The FSRM bit determines if the FSR pin is input or output; if it is configured as output, the FSR is driven inactive, as specified by FSRP. |
| CLKS | I | Input | Input |
| Transmitter Reset ($\text{XRST} = 0$ and $\text{GRST} = 1$) | | | |
| DX | O/Z | High impedance | High impedance |
| CLKX | I/O/Z | Input | The CLKXM bit determines if the CLKX pin is input or output; if it is configured as output, CLKX drives the pin. |
| FSX | I/O/Z | Input | The FSXM bit determines if the FSX pin is input or output; if it is configured as output, FSX is driven inactive as specified by FSXP. |
| CLKS | I | Input | Input |

- **Device reset or McBSP reset:** Resetting the McBSP by device or McBSP reset also resets the state machine to its initial state, and resets all counters and status bits. This includes the receive status bits (RFULL, RRDY, RSYNCERR), and the transmit status bits (XEMPTY, XRDY, XSYNCERR).
- **Device reset:** When the McBSP is reset by device reset, the entire serial port (including the transmitter, receiver, and the sample rate generator) is reset. All input-only pins and 3-state pins should be in a known state. The output-only pin, DX, is in the high-impedance state. For more information on the sample rate generator, see [Section 4.2](#). When the device is pulled out of reset, the serial port remains in the reset condition ($\text{RRST} = \text{XRST} = \text{FRST} = \text{GRST} = 0$). In this reset condition, the serial port pins can be used as general-purpose I/O (see [Section 10](#)).
- **McBSP reset:** When the receiver and transmitter reset bits (*RRST* and *XRST*) are written with a zero, the respective portions of the McBSP reset, and activity in the corresponding section stops. Drive all input-only pins (such as DR and CLKS) and all other pins that are configured as inputs to a known state. FS(R/X) is driven to its inactive state (it is the same as its polarity bit, FS(R/X)P), if it is an output. CLK(R/X) are driven by CLKG if you program them as outputs, provided that $\text{GRST} = 1$. The DX pin is in the high-impedance state when transmitter resets. Write a zero to *GRST* to reset the sample rate generator during normal operation. *GRST* should only be low when neither the transmitter nor the receiver is using the sample rate generator. In this case, the internal sample rate generator clock CLKG, and its frame sync signal (FSG) is driven inactive (low). When the sample rate generator

is not in the reset state ($GRST = 1$), FSR and FSX are in an inactive state when $RRST = 0$ and $XRST = 0$, respectively, even if they are outputs that FSG drives. This ensures that when only one portion of the McBSP is in reset, the other portion can continue operation when $FRST = 1$ and frame sync is driven by FSG. After reset, McBSP disregards the first frame sync and the data in XSR shifts out at the second frame sync (during that time, data written by DMA is ready for transmit), in C6474 devices. In C6474 devices, the McBSP disregards the first frame sync after reset and the data in XSR shifts out at the second frame sync (during that time, data written by DMA is ready for transmit).

- **Sample-rate generator reset:** As mentioned previously, the sample rate generator is reset when the device is reset or when its reset bit, $GRST$, is written with zero. To avoid this error, see [Section 5.5.5](#).

3.2 Determining Ready Status

The $RRDY$ and $XRDY$ bits in $SPCR$ indicate the ready state of the McBSP receiver and transmitter, respectively. Writes and reads from the serial port can be synchronized by any of the following methods:

- Polling $RRDY$ and $XRDY$ bits
- Using the events sent to the DMA or EDMA controller ($REVT$ and $XEVT$)
- Using the interrupts to the CPU ($RINT$ and $XINT$) that the events generate

Reading DRR and writing to DXR affects $RRDY$ and $XRDY$, respectively.

3.2.1 Receive Ready Status: $REVT$, $RINT$, and $RRDY$

$RRDY = 1$ indicates that the RBR contents have been copied to DRR and that the data can now be read by either the CPU or the DMA/EDMA controller. Once that data has been read by either the CPU or the DMA/EDMA controller, $RRDY$ is cleared to 0. Also, at device reset or serial port receiver reset ($RRST = 0$), the $RRDY$ bit is cleared to 0 to indicate that no data has been received and loaded into DRR . $RRDY$ directly drives the McBSP receive event to the DMA/EDMA controller (via $REVT$).

3.2.2 Transmit Ready Status: $XEVT$, $XINT$, and $XRDY$

$XRDY = 1$ indicates that the DXR contents have been copied to XSR and that DXR is ready to be loaded with a new data word. When the transmitter transitions from reset to non-reset ($XRST$ transitions from 0 to 1), $XRDY$ also transitions from 0 to 1 indicating that DXR is ready for new data. Once new data is loaded by the CPU or the DMA/EDMA controller, the $XRDY$ bit is cleared to 0. However, once this data is copied from DXR to XSR , the $XRDY$ bit transitions again from 0 to 1. The CPU or the DMA/EDMA controller can write to DXR although XSR has not yet been shifted out on DX . $XRDY$ directly drives the transmit synchronization event to the DMA/EDMA controller (via $XEVT$).

NOTE: If the polling method is used to service the transmitter, the CPU should wait for one McBSP bit clock ($CLKX$) before polling again to write the next element in DXR . This is because $XRDY$ transitions occur based on bit clock and not CPU clock. The CPU clock is much faster and can cause false $XRDY$ status, leading to data errors due to over-writes.

3.3 CPU Interrupts: $RINT$, $XINT$

The receive interrupt ($RINT$) and transmit interrupt ($XINT$) signals inform the CPU of changes to the serial port status. Four options exist for configuring these interrupts. These options are set by the receive/transmit interrupt mode bits ($RINTM$ and $XINTM$) in $SPCR$. The possible values of the mode, and the configurations they represent, are:

- $(R/X)INTM = 00b$. Reserved.
- $(R/X)INTM = 01b$. Interrupt at the end of a subframe (16 elements or less) within a frame ([Section 8.4](#)).
- $(R/X)INTM = 10b$. Interrupt on detection of frame synchronization pulses. This generates an interrupt even when the transmitter/receiver is in reset. This is done by synchronizing the incoming frame sync pulse to the CPU clock and sending it to the CPU via $(R/X)INT$ ([Section 4.4.4](#)).
- $(R/X)INTM = 11b$. Interrupt on frame synchronization error. If any of the other interrupt modes are selected, $(R/X)SYNCERR$ may be read when servicing the interrupts to detect this condition ([Section 5.5.2](#) and [Section 5.5.5](#)).

3.4 Frame and Clock Configuration

Figure 2 shows typical operation of the McBSP clock and frame sync signals. Serial clocks CLKR and CLKX define the boundaries between bits for receive and transmit, respectively. Similarly, frame sync signals FSR and FSX define the beginning of an element and/or frame transfer. The McBSP allows configuration of the following parameters for data and frame synchronization:

- Polarities of FSR, FSX, CLKX, and CLKR
- A choice of single- or dual-phase frames
- For each phase, the number of elements per frame
- For each phase, the number of bits per element
- Whether subsequent frame synchronization restarts the serial data stream or is ignored
- The data delay from frame synchronization to first data bit which can be 0-, 1-, or 2-bit delays
- Right or left justification as well as sign extension or zero filling for receive data.

The configuration is independent for receive and transmit.

Figure 2. Frame and Clock Operation

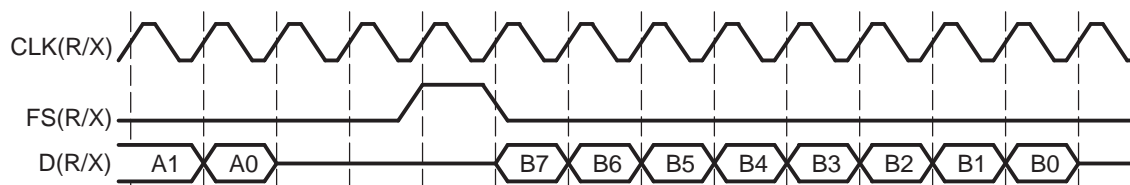

4 Clocks, Frames, and Data

The McBSP has several ways of selecting clocking and framing for both the receiver and transmitter. Clocking and framing can be sent to both portions by the sample rate generator. Each portion can select external clocking and/or framing independently.

Figure 3 is a block diagram of the clock and frame selection circuitry.

Figure 3. Clock and Frame Generation

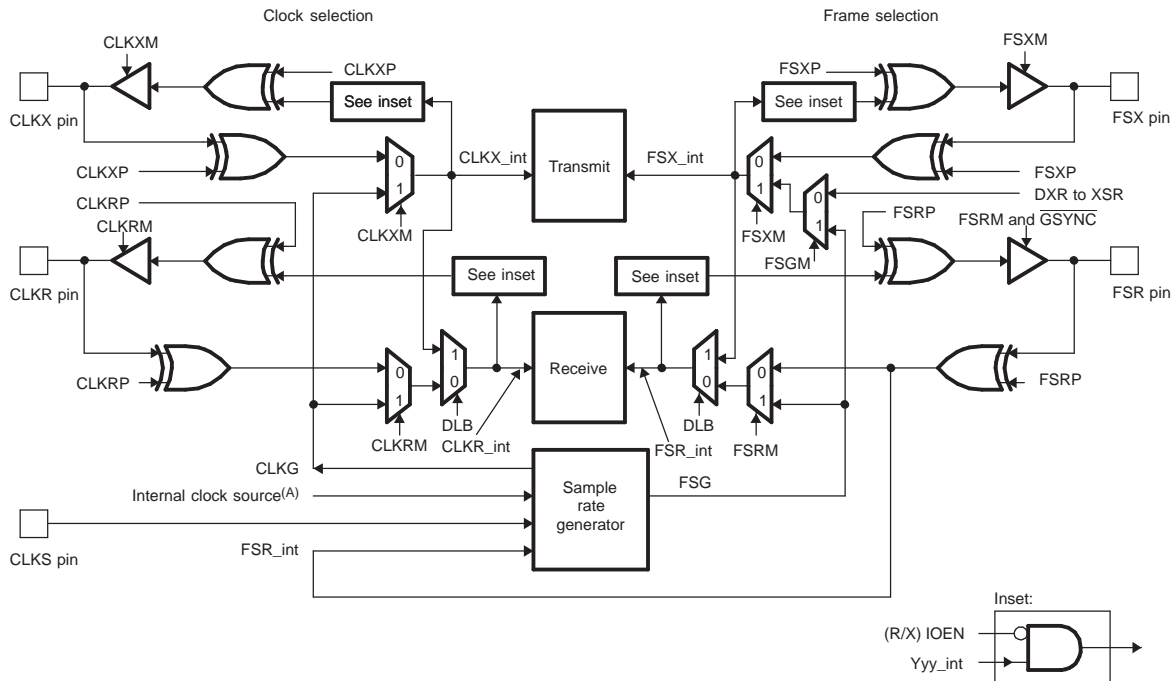

A Internal clock source: CPU/6

4.1 Frame and Clock Operation

Receive and transmit frame sync pulses (FSR/X), and clocks (CLKR/X), can either be generated internally by the sample rate generator (see [Section 4.2](#)) or be driven by an external source. The source of frame sync and clock is selected by programming the mode bits, FS(R/X)M and CLK(R/X)M respectively, in PCR. FSR is also affected by the GSYNC bit in SRGR (for details, see [Section 4.4.2](#)).

When FSR and FSX are inputs (FSXM = FSRM = 0), the McBSP detects them on the internal falling edge of clock, CLKR_int and CLKX_int, respectively (see [Figure 3](#)). The receive data arriving at the DR pin is also sampled on the falling edge of CLKR_int. These internal clock signals are either derived from external source via the CLK(R/X) pins or driven by the sample rate generator clock (CLKG) internal to the McBSP.

When FSR and FSX are outputs driven by the sample rate generator, they are generated (transition to their active state) on the rising edge of the internal clock, CLK(R/X)_int. Similarly, data on DX is output on the rising edge of CLKX_int. For more information, see [Section 4.5.5](#).

FSRP, FSXP, CLKRP, and CLKXP configure the polarities of FSR, FSX, CLKR, and CLKX. All frame sync signals (FSR_int and FSX_int) internal to the serial port are active high. If the serial port is configured for external frame synchronization (FSR/FSX are inputs to the McBSP) and FSRP = FSXP = 1, the external active (low) frame sync signals are inverted before being sent to the receiver signal (FSR_int) and transmitter signal (FSX_int). Similarly, if internal synchronization is selected (FSR/FSX are outputs and GSYNC = 0), the internal active (high) sync signals are inverted if the polarity bit FS(R/X)P = 1, before being sent to the FS(R/X) pin. [Figure 3](#) shows this inversion using XOR gates.

On the transmit side, the transmit clock polarity bit, CLKXP, sets the edge used to shift and clock out transmit data. Data is always transmitted on the rising edge of CLKX_int. If CLKXP = 1 and external clocking is selected (CLKXM = 0 and CLKX is an input), the external falling-edge-triggered input clock on CLKX is inverted to a rising-edge-triggered clock before being sent to the transmitter. If CLKXP = 1 and internal clocking is selected (CLKXM = 1 and CLKX is an output pin), the internal (rising-edge-triggered) clock, CLKX_int, is inverted before being sent out on the CLKX pin.

Similarly, the receiver can reliably sample data that is clocked (by the transmitter) with a rising-edge clock. The receive clock polarity bit, CLKRP, sets the edge used to sample received data. The receive data is always sampled on the falling edge of CLKR_int. Therefore, if CLKRP = 1 and external clocking is selected (CLKRM = 0 and CLKR is an input pin), the external rising-edge triggered input clock on CLKR is inverted to a falling-edge clock before being sent to the receiver. If CLKRP = 1 and internal clocking is selected (CLKRM = 1), the internal falling-edge-triggered clock is inverted to a rising edge before being sent out on the CLKR pin.

In a system where the same clock (internal or external) is used to clock the receiver and transmitter, CLKRP = CLKXP. The receiver uses the opposite edge as the transmitter to ensure valid setup and hold times of data around this edge. [Figure 4](#) shows how data clocked by an external serial device using a rising-edge clock can be sampled by the McBSP receiver with the falling edge of the same clock.

Figure 4. Receive Data Clocking

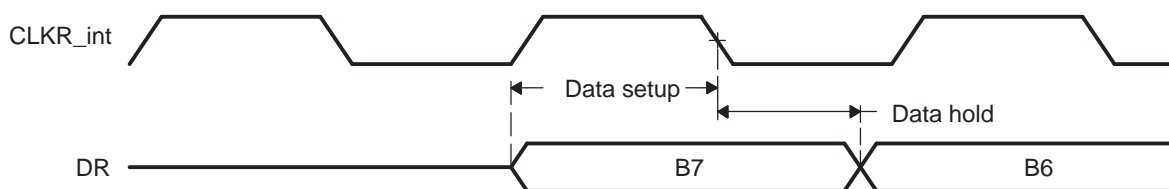
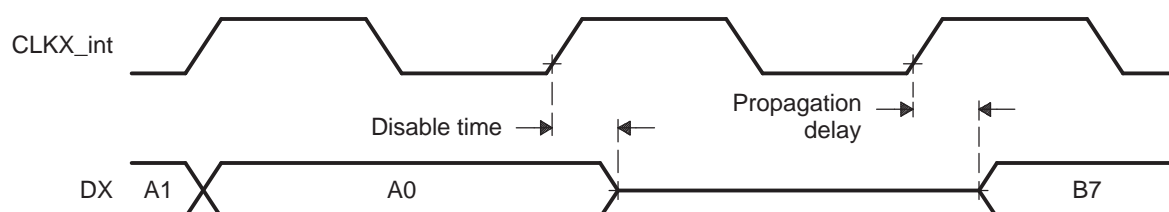

Figure 5. Transmit Data Clocking



4.2 Sample Rate Generator Clocking and Framing

The sample rate generator is composed of a 3-stage clock divider that provides a programmable data clock (CLKG) and framing signal (FSG), as shown in Figure 6. CLKG and FSG are McBSP internal signals that can be programmed to drive receive and/or transmit clocking, CLK(R/X), and framing, FS(R/X). The sample rate generator can be programmed to be driven by an internal clock source or an internal clock derived from an external clock source.

The sample rate generator is not used when CLKX, FSX, CLKR, and FSR are driven by an external source. Therefore, the GRST bit in SPCR does not need to be enabled (GRST = 1) for this setup. The three stages of the sample rate generator circuit compute:

- Clock divide-down (CLKGDV): The number of input clocks per data bit clock
- Frame period (FPER): The frame period in data bit clocks
- Frame width (FWID): The width of an active frame pulse in data bit clocks

In addition, a frame pulse detection and clock synchronization module allows synchronization of the clock divide-down with an incoming frame pulse. The operation of the sample rate generator during device reset is described in Section 3.1.

Figure 6. Sample Rate Generator

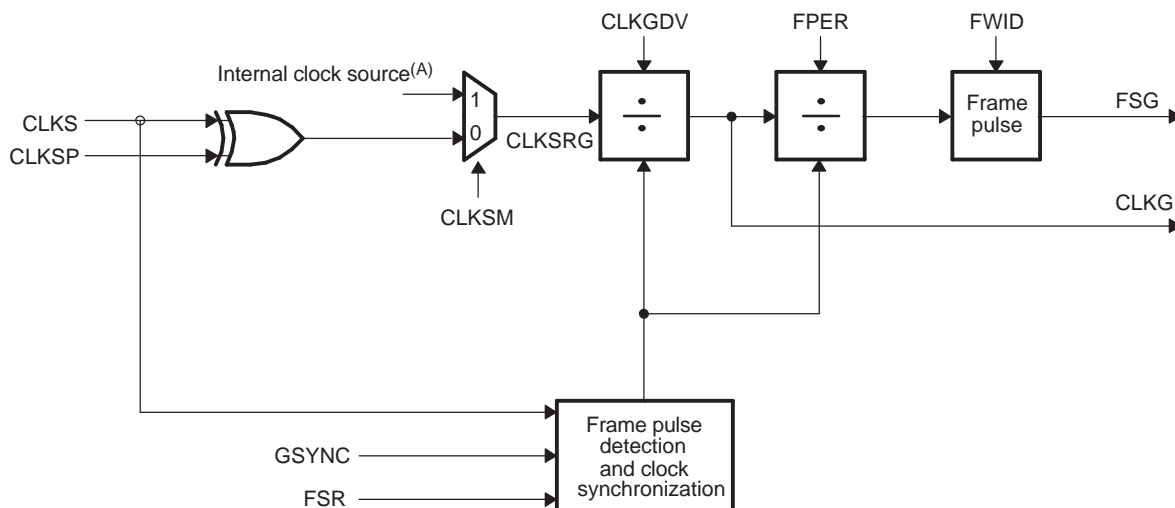

A Internal clock source: CPU/6

4.3 Data Clock Generation

When the receive/transmit clock mode is set to 1 (CLK(R/X)M = 1), the data clocks (CLK(R/X)) are driven by the internal sample rate generator output clock, CLKG. You can select for the receiver and transmitter from a variety of data bit clocks including:

- The input clock to the sample rate generator, which can be either the internal clock source or a dedicated external clock source (CLKS). The C6474 device uses the CPU/4 clock as the internal clock source to the sample rate generator.
- The input clock source (internal clock source or external clock CLKS) to the sample rate generator can be divided down by a programmable value (CLKGDV) to drive CLKG.

Regardless of the source to the sample rate generator, the rising edge of CLKSRG (see [Figure 6](#)) generates CLKG and FSG (see [Section 4.3.3](#)).

4.3.1 Input Clock Source Mode: CLKSM

The CLKSM bit in SRGR selects either the internal clock (CLKSM = 1) or the external clock input (CLKSM = 0), CLKS, as the source for the sample rate generator input clock. Any divide periods are divide-downs calculated by the sample rate generator and are timed by this input clock selection.

4.3.2 Sample Rate Generator Data Bit Clock Rate: CLKGDV

The first divider stage generates the serial data bit clock from the input clock. This divider stage uses a counter that is preloaded by CLKGDV and that contains the divide ratio value. The output of this stage is the data bit clock that is output on the sample rate generator output, CLKG, and that serves as the input for the second and third divider stages.

CLKG has a frequency equal to $1/(\text{CLKGDV} + 1)$ of the sample rate generator input clock. Thus, the sample rate generator input clock frequency is divided by a value between 1 to 256. When CLKGDV is an odd value or equal to 0, the CLKG duty cycle is 50%. Note that an odd CLKGDV value means an even divide down of the source clock and an even CLKGDV value means an odd divide down of the source clock. When CLKGDV is an even value ($2p$), the high state duration is $p + 1$ cycles and the low state duration is p cycles. This is illustrated in the following equations.

In these examples:

S_{IN} = sample generator input clock period

f_{IN} = sample generator input clock frequency

S_G = CLKG period

f_G = CLKG frequency

The following equation is given above: $f_G = f_{IN}/(\text{CLKGDV} + 1)$; therefore, $S_G = (\text{CLKGDV} + 1) \times S_{IN}$.

CLKGDV = 0

$S_G = (\text{CLKGDV} + 1) \times S_{IN} = (0 + 1) \times S_{IN} = S_{IN}$

Pulse width high = $S_{IN} \times (\text{CLKGDV} + 1)/2 = S_{IN} \times (0 + 1)/2 = 0.5 \times S_{IN}$

Pulse width low = $S_{IN} \times (\text{CLKGDV} + 1)/2 = S_{IN} \times (0 + 1)/2 = 0.5 \times S_{IN}$

CLKGDV = 1

$S_G = (\text{CLKGDV} + 1) \times S_{IN} = (1 + 1) \times S_{IN} = 2 \times S_{IN}$

Pulse width high = $S_{IN} \times (\text{CLKGDV} + 1)/2 = S_{IN} \times (1 + 1)/2 = S_{IN}$

Pulse width low = $S_{IN} \times (\text{CLKGDV} + 1)/2 = S_{IN} \times (1 + 1)/2 = S_{IN}$

CLKGDV = 2

$S_G = (\text{CLKGDV} + 1) \times S_{IN} = (2 + 1) \times S_{IN} = 3 \times S_{IN}$

Pulse width high = $S_{IN} \times (\text{CLKGDV}/2 + 1) = S_{IN} \times (2/2 + 1) = 2 \times S_{IN}$

Pulse width low = $S_{IN} \times \text{CLKGDV}/2 = S_{IN} \times 2/2 = 1 \times S_{IN}$

To determine the maximum McBSP bit rate, see the timing requirements in the device-specific data sheet. CLKGDV should be set appropriately to ensure that the McBSP clock rate does not exceed the bit rate limit.

4.3.3 Bit Clock Polarity: CLKSP

The external clock (CLKS) is selected to drive the sample rate generator clock divider by selecting CLKSM = 0. In this case, the CLKSP bit in SRGR selects the edge of CLKS on which sample rate generator data bit clock (CLKG) and frame sync signal (FSG) are generated. Since the rising edge of CLKSRG generates CLKG and FSG, the rising edge of CLKS when CLKSP = 0 or the falling edge of CLKS when CLKSP = 1 causes the transition on CLKG and FSG.

4.3.4 Bit Clock and Frame Synchronization

When CLKS is selected to drive the sample rate generator (CLKSM = 0), GSYNC can be used to configure the timing of CLKG relative to CLKS. GSYNC = 1 ensures that the McBSP and the external device to which it is communicating are dividing down the CLKS with the same phase relationship. If GSYNC = 0, this feature is disabled and CLKG runs freely and is not resynchronized. If GSYNC = 1, an inactive-to-active transition on FSR triggers a resynchronization of CLKG and the generation of FSG. CLKG always begins at a high state after synchronization. Also, FSR is always detected at the same edge of CLKS that generates CLKG, regardless of the length the FSR pulse. Although an external FSR is provided, FSG can still drive internal receive frame synchronization when GSYNC = 1. When GSYNC = 1, FPER is a don't care, because the frame period is determined by the arrival of the external frame sync pulse.

Figure 7 and Figure 8 show this operation with various polarities of CLKS and FSR. These figures assume that FWID is 0, for a FSG = 1 CLKG wide.

These figures show what happens to CLKG when it is initially in sync and GSYNC = 1, as well as when it is not in sync with the frame synchronization and GSYNC = 1.

Figure 7. CLKG Synchronization and FSG Generation When GSYNC = 1 and CLKGDV = 1

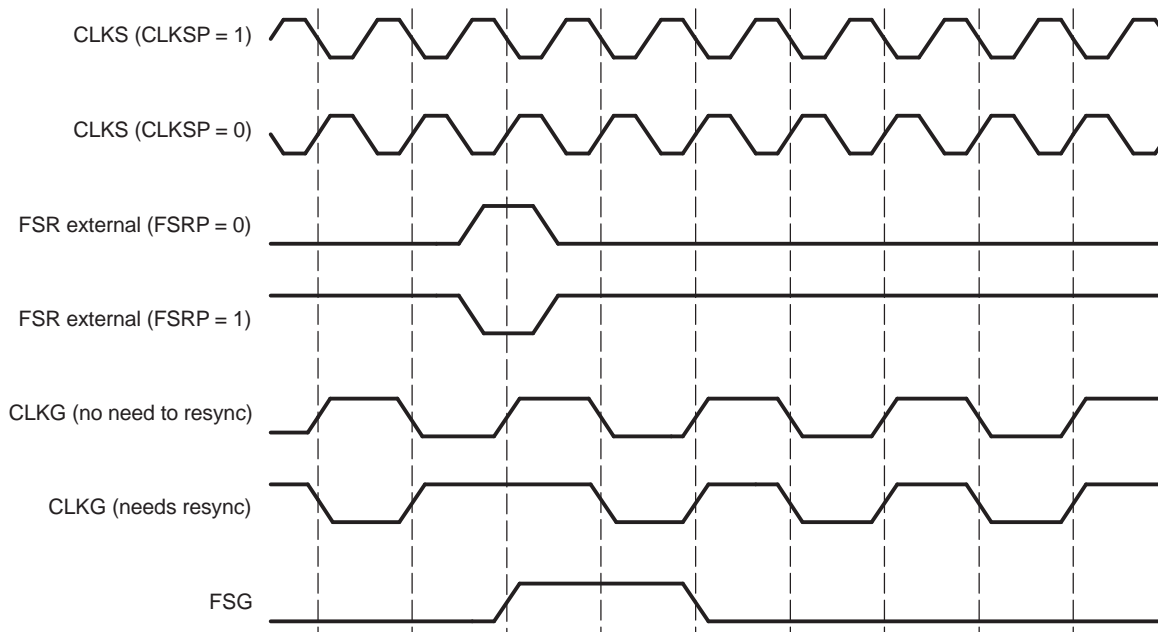
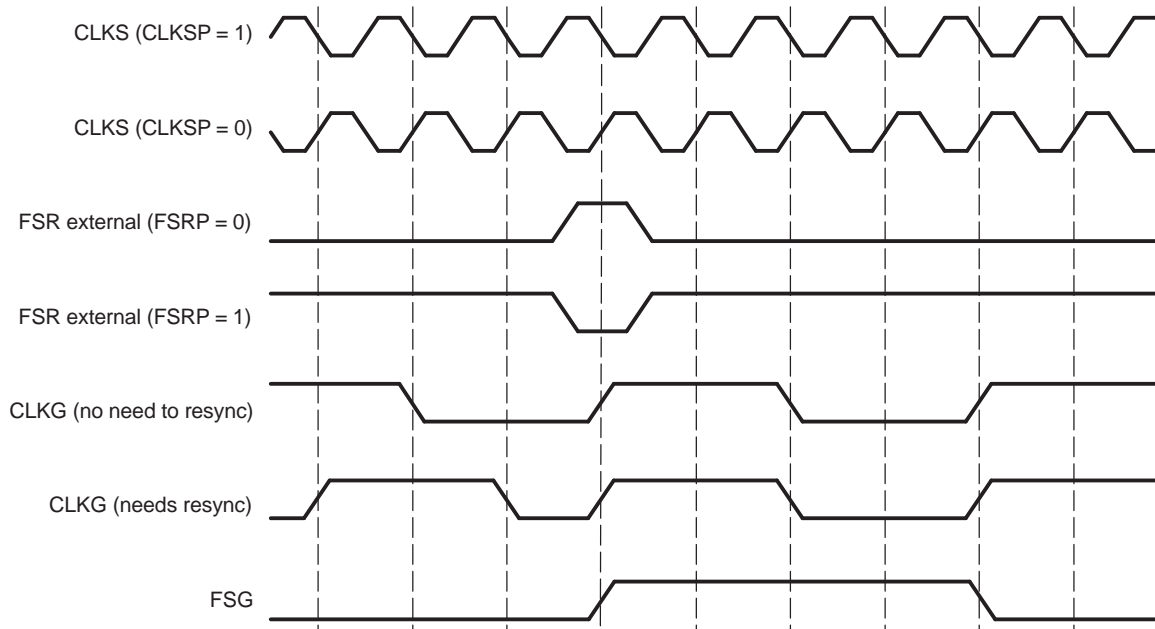

Figure 8. CLKG Synchronization and FSG Generation When GSYNC = 1 and CLKGDV = 3

When $GSYNC = 1$, the transmitter can operate synchronously with the receiver, provided that the following conditions are met:

- FSX is programmed to be driven by the sample rate generator frame sync, FSG ($FSGM = 1$ in SRGR and $FSXM = 1$ in PCR).
- The sample-rate generator clock should drive the transmit and receive bit clock ($CLK(R/X)M = 1$ in SPCR). Therefore, the $CLK(R/X)$ pin should not be driven by any other source.

4.3.5 Digital Loopback Mode: DLB

Setting $DLB = 1$ in SPCR enables digital loopback mode. In DLB mode, DR, FSR, and CLKR are internally connected through multiplexers to DX, FSX, and CLKX, respectively, as shown in [Figure 3](#) and [Figure 41](#). DLB mode allows testing of serial port code with a single DSP device. DLB mode cannot be used when the McBSP is in clock stop mode ($CLKSTP = 1x$ in SPCR). CLKX and FSX must be enabled as outputs ($CLKXM = FSXM = 1$) in DLB mode.

4.3.6 Receive Clock Selection: DLB, CLKRM

Table 3 shows how the digital loopback bit (DLB) and the CLKRM bit in PCR select the receiver clock. In digital loopback mode (DLB = 1), the transmitter clock drives the receiver. CLKRM determines whether the CLKR pin is an input or an output.

Table 3. Receive Clock Selection

| DLB Bit in SPCR | CLKRM Bit in PCR | Source of Receive Clock | CLKR Function |
|-----------------|------------------|---|--|
| 0 | 0 | CLKR acts as an input driven by the external clock and inverted as determined by CLKRP before being used. | Input. |
| 0 | 1 | The sample rate generator clock (CLKG) drives CLKR. | Output. CLKG inverted as determined by CLKRP before being driven out on CLKR. |
| 1 | 0 | CLKX_int drives the receive clock CLKR_int as selected and is inverted (see Table 4). | High impedance. |
| 1 | 1 | CLKX_int drives CLKR_int as selected and is inverted (see Table 4). | Output. CLKR (same as CLKX) inverted as determined by CLKRP before being driven out. |

4.3.7 Transmit Clock Selection: CLKXM

Table 4 shows how the CLKXM bit in PCR selects the transmit clock and whether the CLKX pin is an input or output.

Table 4. Transmit Clock Selection

| CLKXM Bit in PCR | Source of Transmit Clock | CLKX Function |
|------------------|--|--|
| 0 | The external clock drives the CLKX input pin. CLKX is inverted as determined by CLKXP before being used. | Input. |
| 1 | The sample rate generator clock, CLKG, drives the transmit clock | Output. CLKG is inverted as determined by CLKXP before being driven out on CLKX. |

4.3.8 Stopping Clocks

There are two methods to stop serial clocks between data transfers. One method is using the SPI CLKSTP mode where clocks are stopped between single-element transfers. This is described in Section 9.

The other method is when the clocks are inputs to the McBSP (CLKXM or CLKRM = 0) and the McBSP operates in non-SPI mode. This means that clocks can be stopped between data transfers. If the external device stops the serial clock between data transfers, the McBSP interprets it as a slow-down serial clock. Ensure that there are no glitches on the CLK(R/X) lines as the McBSP may interpret them as clock-edge transitions. Restarting the serial clock is equivalent to a normal clock transition after a slow CLK(R/X) cycle. Note that just as in normal operations, transmit under flow (XEMPTY) may occur if the DXR is not properly serviced at least three CLKX cycles before the next frame sync. Therefore if the serial clock is stopped before DXR is properly serviced, the external device needs to restart the clock at least three CLKX cycles before the next frame sync to allow the DXR write to be properly synchronized. For a graphical explanation on when the DXR needs to be written to avoid underflow, see Figure 35.

4.4 Frame Sync Generation

Data frame synchronization is independently programmable for the receiver and the transmitter for all data delay values. When set to 1, the FRST bit in SPCR activates the frame generation logic to generate frame sync signals, provided that FSGM = 1 in SRGR. The frame sync programming options are:

- A frame pulse with a programmable period between sync pulses and a programmable active width specified in the sample rate generator register (SRGR).
- The transmitter can trigger its own frame sync signal that is generated by a DXR-to-XSR copy. This causes a frame sync to occur on every DXR-to-XSR copy. The data delays can be programmed as required. However, maximum packet frequency cannot be achieved in this method for data delays of 1 and 2.
- Both the receiver and transmitter can independently select an external frame synchronization on the FSR and FSX pins, respectively.

4.4.1 Frame Period (FPER) and Frame Width (FWID)

The FPER block is a 12-bit down counter that can count down the generated data clocks from 4095 to 0. FPER controls the period of active frame sync pulses. The FWID block in the sample rate generator is an 8-bit down counter. The FWID field controls the active width of the frame sync pulse. When the sample rate generator comes out of reset, FSG is in an inactive (low) state. After this, when FRST = 1 and FSGM = 1, frame sync signals are generated. The frame width value (FWID + 1) is counted down on every CLKG cycle until it reaches 0 when FSG goes low. Thus, the value of FWID + 1 determines an active frame pulse width ranging from 1 to 256 data bit clocks. At the same time, the frame period value (FPER + 1) is also counting down, and when this value reaches 0, FSG goes high again, indicating a new frame is beginning. Thus, the value of FPER + 1 determines a frame length from 1 to 4096 data bits. When GSYNC = 1, the value of FPER does not matter. [Figure 9](#) shows a frame of 16 CLKG periods (FPER = 15 or 0000 1111b).

Figure 9. Programmable Frame Period and Width

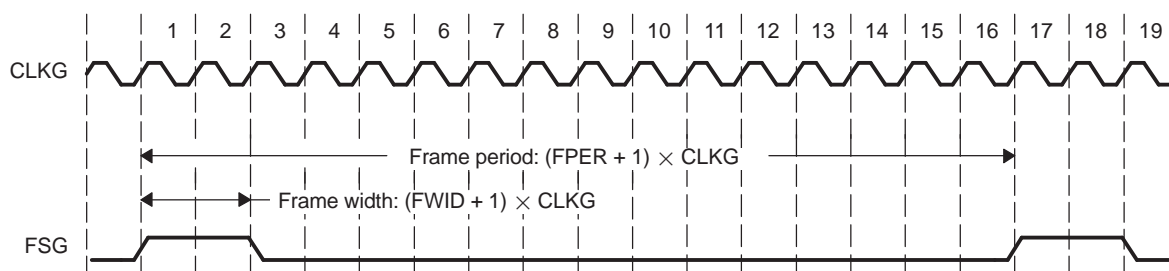

It is recommended that you program FWID to a value less than (R/X) WDLEN1/2.

4.4.2 Receive Frame Sync Selection: DLB, FSRM, GSYNC

Table 5 shows how you can select various sources to provide the receive frame synchronization signal. Note that in digital loopback mode (DLB = 1), the transmit frame sync signal is used as the receive frame sync signal and that DR is internally connected to DX.

Table 5. Receive Frame Synchronization Selection

| DLB Bit in SPCR | FSRM Bit in PCR | GSYNC Bit in SRGR | Source of Receive Frame Synchronization | FSR Pin Function |
|-----------------|-----------------|-------------------|--|---|
| 0 | 0 | X | External frame sync signal drives the FSR input pin, whose signal is then inverted as determined by FSRP before being used as FSR_int. | Input. |
| 0 | 1 | 0 | Sample rate generator frame sync signal (FSG) drives FSR_int, FRST = 1. | Output. FSG is inverted as determined by FSRP before being driven out on the FSR pin. |
| 0 | 1 | 1 | Sample rate generator frame sync signal (FSG) drives FSR_int, FRST = 1. | Input. The external frame sync input on FSR is used to synchronize CLKG and generate FSG. |
| 1 | 0 | 0 | FSX_int drives FSR_int. FSX is selected as shown in Table 6. | High impedance. |
| 1 | X | 1 | FSX_int drives FSR_int and is selected as shown in Table 6. | Input. External FSR is not used for frame synchronization but is used to synchronize CLKG and generate FSG since GSYNC = 1. |
| 1 | 1 | 0 | FSX_int drives FSR_int and is selected as shown in Table 6. | Output. Receive (same as transmit) frame synchronization is inverted as determined by FSRP before being driven out. |

4.4.3 Transmit Frame Sync Selection: FSXM, FSGM

Table 6 shows how you can select the source of the transmit frame synchronization signal. The three choices are:

- External frame sync input
- The sample rate generator frame sync signal, FSG
- A signal that indicates a DXR-to-XSR copy has been made

Table 6. Transmit Frame Synchronization Selection

| FSXM Bit in PCR | FSGM Bit in SRGR | Source of Transmit Frame Synchronization | FSX Pin Function |
|-----------------|------------------|--|--|
| 0 | X | External frame sync input on the FSX pin. This is inverted by FSXP before being used as FSX_int. | Input. |
| 1 | 1 | Sample rate generator frame sync signal (FSG) drives FSX_int. FRST = 1. | Output. FSG is inverted by FSXP before being driven out on FSX. |
| 1 | 0 | A DXR-to-XSR copy activates transmit frame sync signal. | Output. 1-bit-clock-wide signal inverted as determined by FSXP before being driven out on FSX. |

4.4.4 Frame Detection for Initialization

To facilitate detection of frame synchronization, program the receive and transmit CPU interrupts (RINT and XINT) to detect frame synchronization by setting RINTM = XINTM = 10b in SPCR. Unlike other types of serial port interrupts, this one can operate while the associated portion of the serial port is in reset (for example, RINT can be activated while the receiver is in reset). The FS(R/X)M and FS(R/X)P still select the appropriate source and polarity of frame synchronization. Thus, even when the serial port is in reset, these signals are synchronized to the CPU clock and then sent to the CPU in the form of RINT and XINT at the point at which they feed the receive and transmit portions of the serial port. A new frame synchronization pulse can be detected, after which the CPU can safely take the serial port out of reset.

4.5 Data and Frames

4.5.1 Frame Synchronization Phases

Frame synchronization indicates the beginning of a transfer on the McBSP. The data stream following frame synchronization can have up to two phases, phase 1 and phase 2. The number of phases can be selected by the phase bit, (R/X)PHASE, in RCR and XCR. The number of elements per frame and bits per element can be independently selected for each phase via (R/X)FRLEN1/2 and (R/X)WDLEN1/2, respectively. Figure 10 shows a frame in which the first phase consists of two elements of 12 bits, each followed by a second phase of three elements of 8 bits each. The entire bit stream in the frame is contiguous; no gaps exist either between elements or phases. Table 7 shows the fields in the receive/transmit control registers (RCR/XCR) that control the frame length and element length for each phase for both the receiver and the transmitter. The maximum number of elements per frame is 128 for a single-phase frame and 256 elements in a dual-phase frame. The number of bits per element can be 8, 12, 16, 20, 24, or 32.

NOTE: For a dual-phase frame with internally generated frame sync, the maximum number of elements per phase depends on the word length. This is because the frame period, FPER, is only 12-bits wide and thus provides 4096 bits per frame. Hence, the maximum number of 256 elements per dual-phase frame applies only when the WDLEN is 16-bits. However, any combination of element numbers and element size (defined by FRLEN and WDLEN, respectively) is valid as long as their product is less than or equal to 4096 bits. This limitation does not apply for dual-phase with external frame sync.

Figure 10. Dual-Phase Frame Example

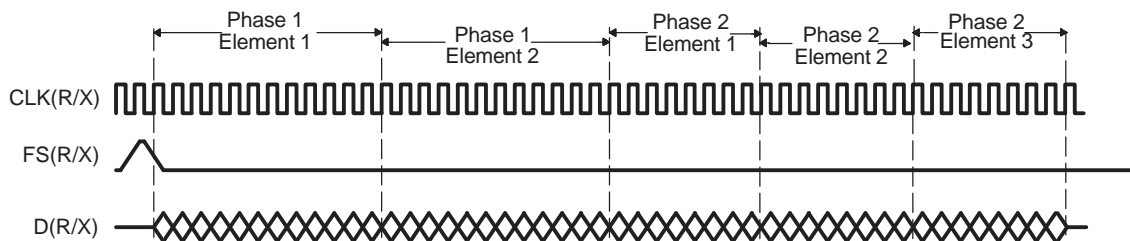

Table 7. RCR/XCR Fields Controlling Elements per Frame and Bits per Element

| Serial Port McBSP0/1 | Frame Phase | RCR/XCR Field Control | |
|----------------------|-------------|-----------------------|------------------|
| | | Elements per Frame | Bits per Element |
| Receive | 1 | RFRLEN1 | RWDLEN1 |
| Receive | 2 | RFRLEN2 | RWDLEN2 |
| Transmit | 1 | XFRLEN1 | XWDLEN1 |
| Transmit | 2 | XFRLEN2 | XWDLEN2 |

4.5.2 Frame Length: RFRLLEN1/2, XFRLEN1/2

Frame length specifies the maximum number of serial elements or logical time slots or channels that are available for transfer per frame synchronization signal. In multichannel selection mode, the frame length value is independent of (and perhaps different from) the actual number of channels that the DSP is programmed to receive or transmit per frame via the MCR, RCER, and XCER registers. For details on multichannel selection mode operation, see [Section 8](#). The 7-bit (R/X)FRLEN1/2 bits in (R/X)CR support up to 128 elements per phase in a frame, as shown in [Table 8](#). (R/X)PHASE = 0 selects a single-phase data frame, and (R/X)PHASE = 1 selects a dual-phase frame for the data stream. For a single-phase frame, the value of (R/X)FRLEN2 does not matter. Program the frame length fields with (w minus 1), where w represents the number of elements per frame. For [Figure 10](#), (R/X)FRLEN1 = 1 or 000 0001b and (R/X)FRLEN2 = 2 or 000 0010b.

Table 8. Receive/Transmit Frame Length Configuration

| (R/X)PHASE | (R/X)FRLEN1 | (R/X)FRLEN2 | Frame Length |
|------------|---------------------|---------------------|---|
| 0 | $0 \leq n \leq 127$ | x | Single-phase frame; (n+1) elements per frame |
| 1 | $0 \leq n \leq 127$ | $0 \leq m \leq 127$ | Dual-phase frame; (n+1) plus (m+1) elements per frame |

4.5.3 Element Length: RWDLEN1/2, XWDLEN1/2

The (R/X)WDLEN1/2 fields in the receive/transmit control register (RCR and XCR) determine the element length in bits per element for the receiver and the transmitter for each phase of the frame, as indicated in [Table 7](#). [Table 9](#) shows how the value of these fields selects particular element lengths in bits. For the example in [Figure 10](#), (R/X)WDLEN1 = 001b and (R/X)WDLEN2 = 000b. If (R/X)PHASE = 0, indicating a single-phase frame, (R/X)WDLEN2 is not used by the McBSP and its value does not matter.

Table 9. Receive/Transmit Element Length Configuration

| (R/X)WDLEN1/2 | Element Length (Bits) |
|---------------|-----------------------|
| 000 | 8 |
| 001 | 12 |
| 010 | 16 |
| 011 | 20 |
| 100 | 24 |
| 101 | 32 |
| 110 | Reserved |
| 111 | Reserved |

4.5.4 Data Packing using Frame Length and Element Length

The frame length and element length can be manipulated to effectively pack data. For example, consider a situation in which four 8-bit elements are transferred in a single-phase frame, as shown in Figure 11. In this case:

- (R/X)PHASE = 0, indicating a single-phase frame
- (R/X)FRLLEN1 = 000 0011b, indicating a 4-element frame
- (R/X)WDLEN1 = 000b, indicating 8-bit elements

In this example, four 8-bit data elements are transferred to and from the McBSP by the CPU or the DMA/EDMA controller. Four reads of DRR and four writes of DXR are necessary for each frame.

Figure 11. Single-Phase Frame and Four 8-Bit Elements

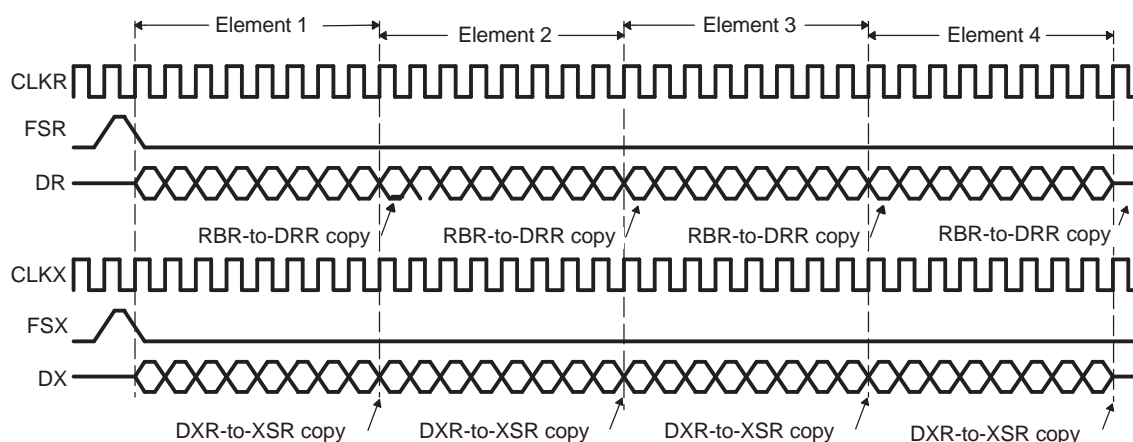

The example in Figure 11 can also be viewed as a data stream of a single-phase frame of one 32-bit data element, as shown in Figure 12. In this case:

- (R/X)PHASE = 0, indicating a single phase frame
- (R/X)FRLLEN1 = 0b, indicating a 1-element frame
- (R/X)WDLEN1 = 101b, indicating 32-bit elements

In this example, one 32-bit data element is transferred to and from the McBSP by the CPU or the DMA/EDMA controller. Thus, one read of DRR and one write of DXR is necessary for each frame. As a result, the number of transfers is one-fourth that of the previous example (Figure 11). This manipulation reduces the percentage of bus time required for serial port data movement.

Figure 12. Single-Phase Frame of One 32-Bit Element

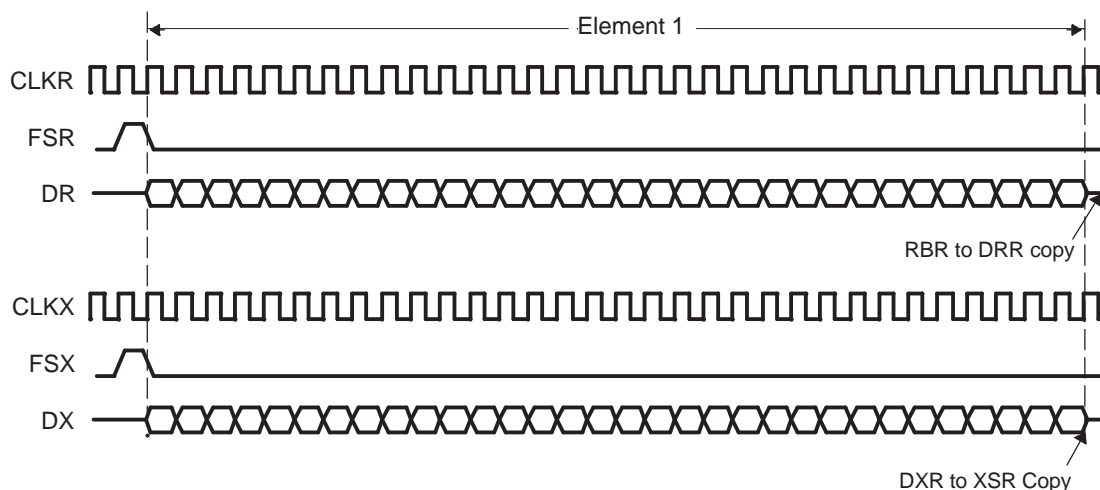

4.5.5 Data Delay: RDATDLY, XDATDLY

The start of a frame is defined by the first clock cycle in which frame synchronization is active. The beginning of actual data reception or transmission with respect to the start of the frame can be delayed if required. This delay is called data delay. RDATDLY and XDATDLY specify the data delay for reception and transmission, respectively. The range of programmable data delay is zero to two bit clocks ((R/X)DATDLY = 00b to 10b), as shown in Figure 13. Typically, a 1-bit delay is selected because data often follows a 1-cycle active frame sync pulse.

Figure 13. Data Delay

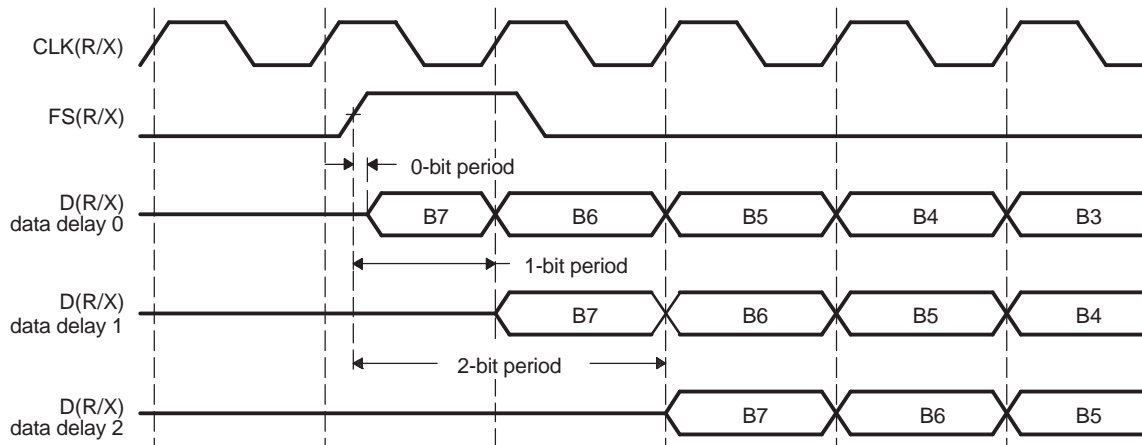

Normally a frame sync pulse is detected or sampled with respect to an edge of serial clock CLK(R/X). Thus, on a subsequent cycle (depending on data delay value), data can be received or transmitted. However, in the case of a 0-bit data delay, the data must be ready for reception and/or transmission on the same serial clock cycle. For reception, this problem is solved by receive data being sampled on the first falling edge of CLKR when an active (high) FSR is detected. However, data transmission must begin on the rising edge of CLKX that generated the frame synchronization. Therefore, the first data bit is assumed to be in the XSR and DX. The transmitter then asynchronously detects the frame synchronization, FSX goes active, and it immediately starts driving the first bit to be transmitted on the DX pin.

Another common operation uses a data delay of 2. This configuration allows the serial port to interface to different types of T1 framing devices in which the data stream is preceded by a framing bit. During the reception of such a stream with a data delay of two bits, the framing bit appears after a 1-bit delay and data appears after a 2-bit delay. The serial port essentially discards the framing bit from the data stream, as shown in Figure 14. In transmission, by delaying the first transfer bit, the serial port essentially inserts a blank period (high-impedance period) in place of the framing bit. Here, it is expected that the framing device inserts its own framing bit or that the framing bit is generated by another device. Alternatively, you may pull up or pull down DX to achieve the desired value.

Figure 14. Bit Data Delay Used to Discard Framing Bit

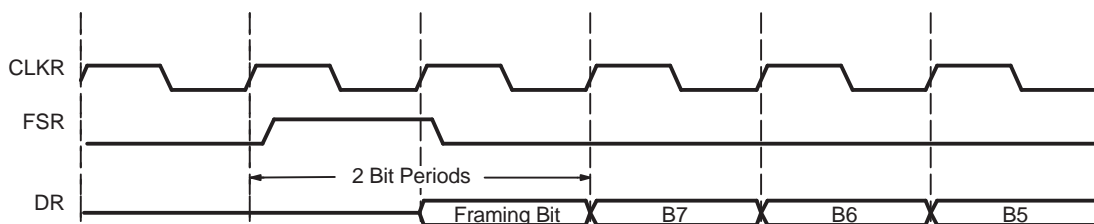

4.5.6 Receive Data Justification and Sign Extension: RJUST

RJUST in SPCR selects whether data in RBR is right- or left-justified (with respect to the MSB) in the DRR. If right justification is selected, RJUST further selects whether the data is sign-extended or zero-filled. [Table 10](#) and [Table 11](#) summarize the effect that various values of RJUST have on example receive data.

Table 10. Effect of RJUST Bit Values With 12-Bit Example Data ABCh

| RJUST Bits Value | Justification | Extension | Value in DRR |
|------------------|---------------|------------------|------------------|
| 00 | Right | Zero-fill MSBs | 0x000A : 0xBCDE |
| 01 | Right | Sign-extend MSBs | 0xFFFFA : 0xBCDE |
| 10 | Left | Zero-fill LSBs | 0xABCD : 0xE000 |
| 11 | Reserved | Reserved | Reserved |

Table 11. Effect of RJUST Bit Values With 20-Bit Example Data ABCDEh

| RJUST Bits Value | Justification | Extension | Value in DRR |
|------------------|---------------|------------------|------------------|
| 00 | Right | Zero-fill MSBs | 0x000A : 0xBCDE |
| 01 | Right | Sign-extend MSBs | 0xFFFFA : 0xBCDE |
| 10 | Left | Zero-fill LSBs | 0xABCD : 0xE000 |
| 11 | Reserved | Reserved | Reserved |

4.5.7 32-Bit Bit Reversal: RWDREVRs, XWDREVRs

The 32-bit bit reversal feature is only available on the C6474 McBSP. Normally, all transfers are sent and received with the MSB first. However, you can reverse the receive/transmit bit ordering of a 32-bit element (LSB first) by setting all of the following:

- (R/X)WDLEN(1/2) = 101b in RCR/XCR to indicate 32-bit elements.
- (R/X)WDREVRs = 1 in the receive/transmit control register (RCR/XCR).
- (R/X)COMPAND = 00b in RCR/XCR.

When you set the register fields as above, the bit ordering of the 32-bit element is reversed before being received by or sent from the serial port. If the (R/W)WDREVRs and (R/X)COMPAND fields are set as indicated above, but the element size is not set to 32-bit, operation is undefined.

4.6 Clocking and Framing Examples

4.6.1 Multiphase Frame Example: AC97

[Figure 15](#) shows an example of the Audio Codec '97 (AC97) standard, which uses the dual-phase frame feature. The first phase consists of a single 16-bit element. The second phase consists of 12 20-bit elements. The phases are configured as follows:

- (R/X)PHASE = 1b: specifying a dual-phase frame
- (R/X)FRLLEN1 = 0b: specifying one element per frame in phase 1
- (R/X)WDLEN1 = 010b: specifying 16 bits per element in phase 1
- (R/X)FRLLEN2 = 000 1011b: specifying 12 elements per frame in phase 2
- (R/X)WDLEN2 = 011b: specifying 20 bits per element in phase 2
- CLK(R/X)P = 0: specifying that the receive data sampled on the falling edge of CLKR and the transmit data are clocked on the rising edge of CLKX
- FS(R/X)P = 0: indicating that active frame sync signals are used
- (R/X)DATDLY = 01b: indicating a data delay of one bit clock

Figure 15. AC97 Dual-Phase Frame Format

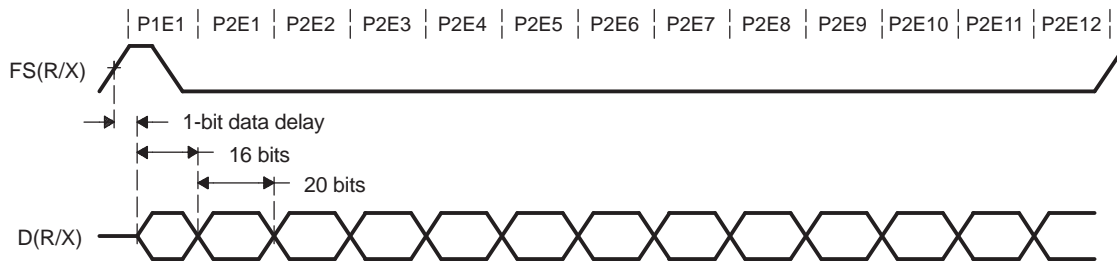

A PxEy = phase x and element y.

Figure 15 shows the AC97 timing near frame synchronization. First the frame sync pulse itself overlaps the first element. In McBSP operation, the inactive-to-active transition of the frame synchronization signal actually indicates frame synchronization. For this reason, frame synchronization can be high for an arbitrary number of bit clocks. Only after the frame synchronization is recognized as inactive and then active again is the next frame synchronization recognized.

In Figure 16, there is a 1-bit data delay. Regardless of the data delay, transmission can occur without gaps. The last bit of the previous (last) element in phase 2 is immediately followed by the first data bit of the first element in phase 1 of the next data frame.

Figure 16. AC97 Bit Timing Near Frame Synchronization

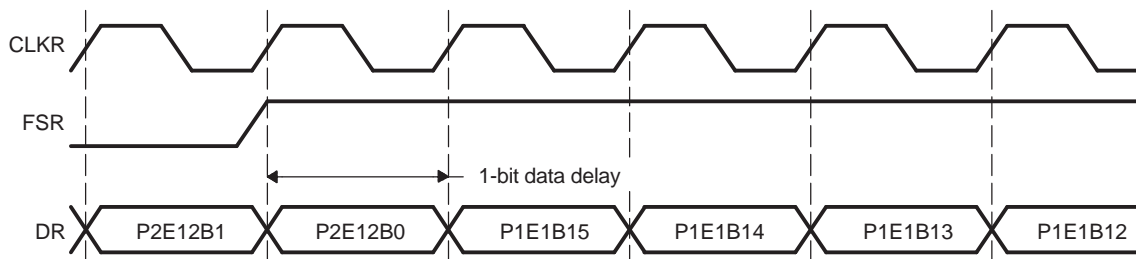

A PxEyBz = phase x, element y, and bit z.

4.6.2 Double-Rate ST-BUS Clock

Figure 17 shows the pin connections of a McBSP to a typical Mitel ST-BUS™ device. Figure 18 shows the McBSP timing to be compatible with the Mitel ST-BUS. The operation is running at maximum frame frequency.

- CLK(R/X)M = 1: CLK(R/X)_int generated internally by the sample rate generator
- GSYNC = 1: CLKG is synchronized with the external frame sync signal input on FSR. CLKG is not synchronized (it runs freely) until the frame sync signal is active. Also, FSR is regenerated internally to form a minimum pulse width. FPER and FWID are don't cares.
- CLKSM = 0: external clock (CLKS) drives the sample rate generator
- CLKSP = 1: falling edge of CLKS generates CLKG and thus CLK(R/X)_int
- CLKGDV = 1: receive clock (shown as CLKR) is half of CLKS frequency
- FS(R/X)P = 1: active (low) frame sync pulse
- (R/X)FRLN1 = 11111b: 32 elements per frame
- (R/X)WDLEN1 = 0: 8-bit element
- (R/X)PHASE = 0: single-phase frame and (R/X)FRLN2 = (R/X)WDLEN2 = X
- (R/X)DATDLY = 0: no data delay
- FRST = 1: frame-sync generator is out of reset and is able to generate frame-sync signal (FSG) to be used by transmit and receive sections
- FSRM = 1: receive frame-sync signal is driven internally by the sample-rate generator frame-sync signal (FSG)
- FSGM = 1: transmit frame-sync signal is driven by the sample-rate generator frame-sync signal (FSG)

- FSXM = 1: transmitter uses internally-generated frame-sync signal and is available at the FSX pin

NOTE: The FSX and FSR pins should not be connected together.

Figure 17. McBSP to ST-BUS Block Diagram

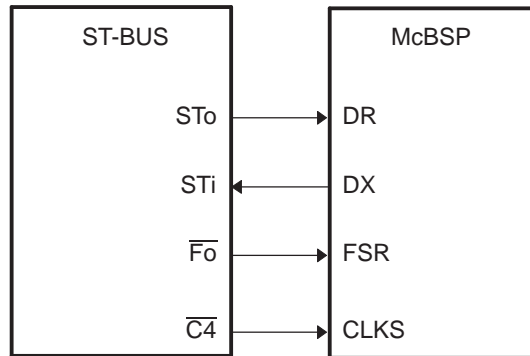
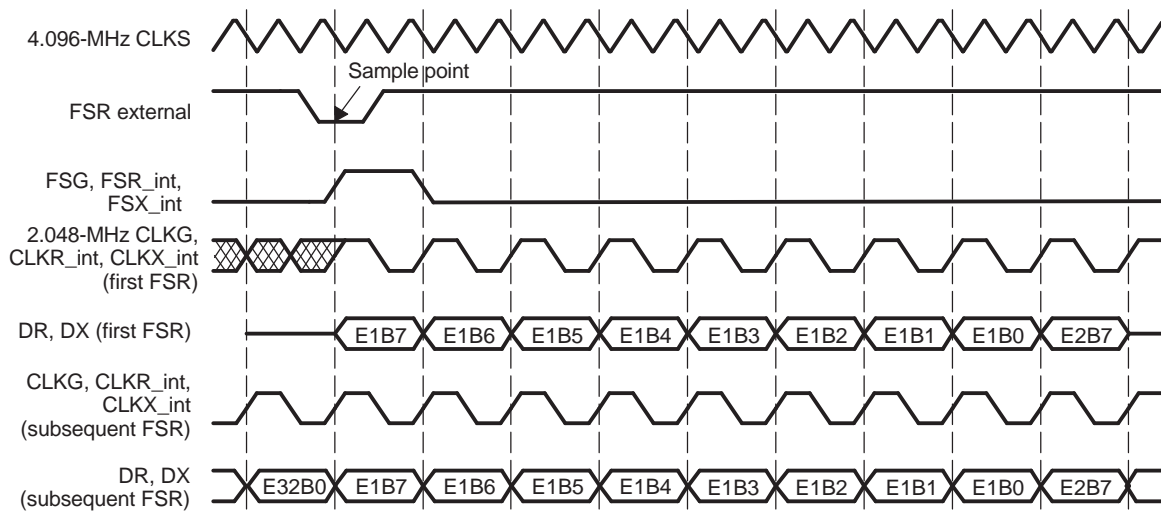

Figure 18. Double-Rate ST-BUS Clock Example



4.6.3 Single-Rate ST-BUS Clock

The example in Figure 19 is the same as the ST-BUS example, except for the following items:

- CLKGDV = 0: CLKS drives CLK(R/X)_int without any divide down (single-rate clock).
- CLKSP = 0: The rising edge of CLKS generates internal clocks CLKG and CLK(R/X)_int.

The rising edge of CLKS detects the external FSR. This external frame sync pulse resynchronizes the internal McBSP clocks and generates the frame sync for internal use. The internal frame sync is generated so that it is wide enough to be detected on the falling edge of the internal clocks.

Figure 19. Single-Rate ST-BUS Clock Example

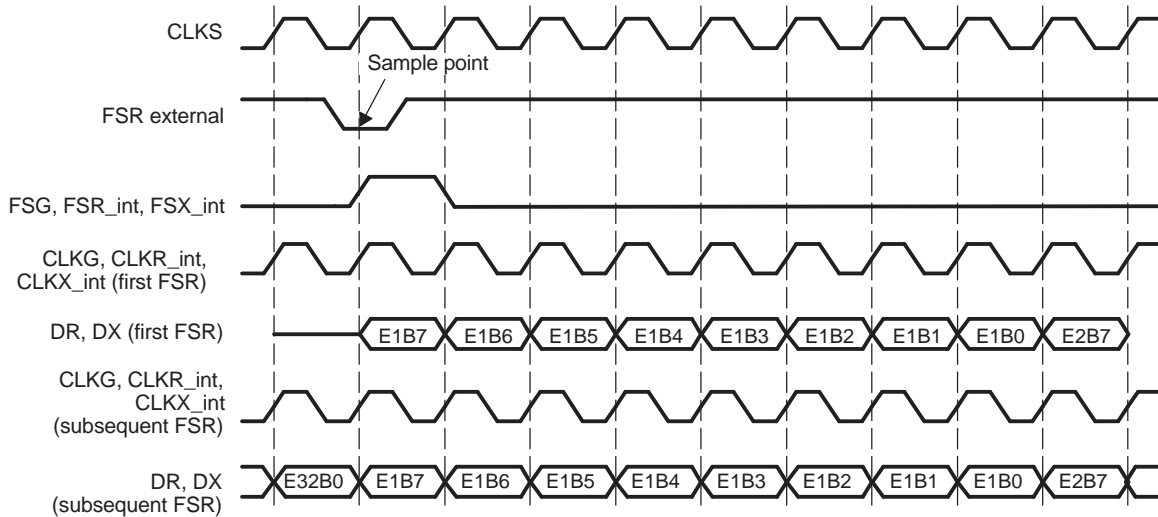

4.6.4 Double-Rate Clock

The example in [Figure 20](#) is the same as the ST-BUS example, except for the following:

- CLKSP = 0: The rising edge of CLKS generates CLKG and CLK(R/X).
- CLKGDV = 1: CLKG, CLKR_int, and CLKX_int frequencies are half of the CLKS frequency.
- GSYNC = 0: CLKS drives CLKG. CLKG runs freely and is not resynchronized by FSR.
- FS(R/X)M = 0: Frame synchronization is externally generated. The framing pulse is wide enough to be detected.
- FS(R/X)P = 0: Active (high) input frame sync signal.
- (R/X)DATDLY = 1: Specifies a data delay of one bit.

Figure 20. Double-Rate Clock Example

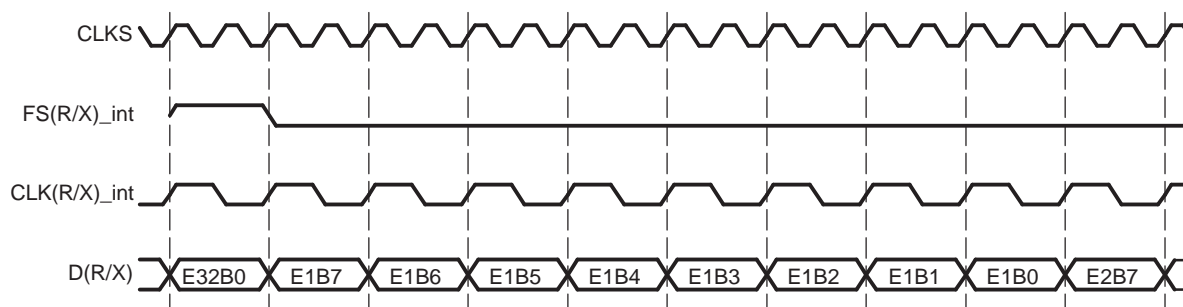

5 McBSP Standard Operation

During a serial transfer, there are typically periods of serial port inactivity between packets or transfers. The receive and transmit frame synchronization pulse occurs for every serial transfer. When the McBSP is not in the reset state and has been configured for the desired operation, a serial transfer can be initiated by programming (R/X)PHASE = 0 for a single-phase frame with the required number of elements programmed in (R/X)FRLLEN1. The number of elements can range from 1 to 128 ((R/X)FRLLEN1 = 00h to 7Fh). The required serial element length is set in the (R/X)WDLEN1 field in the (R/X)CR. If a dual-phase frame is required for the transfer, RPHASE = 1 and each (R/X)FRLLEN1/2 can be set to any value between 0h and 7Fh.

Figure 21 shows a single-phase data frame of one 8-bit element. Since the transfer is configured for a 1-bit data delay, the data on the DX and DR pins are available one bit clock after FS(R/X) goes active. This figure, as well as all others in this section, use the following assumptions:

- (R/X)PHASE = 0, specifying a single-phase frame
- (R/X)FRLLEN1 = 0b, specifying one element per frame
- (R/X)WDLEN1 = 000b, specifying eight bits per element
- (R/X)FRLLEN2 = (R/X)WDLEN2 = Value is ignored
- CLK(R/X)P = 0, specifying that the receive data is clocked on the falling edge and that transmit data is clocked on the rising edge
- FS(R/X)P = 0, specifying that active (high) frame sync signals are used
- (R/X)DATDLY = 01b, specifying a 1-bit data delay

Figure 21. McBSP Standard Operation

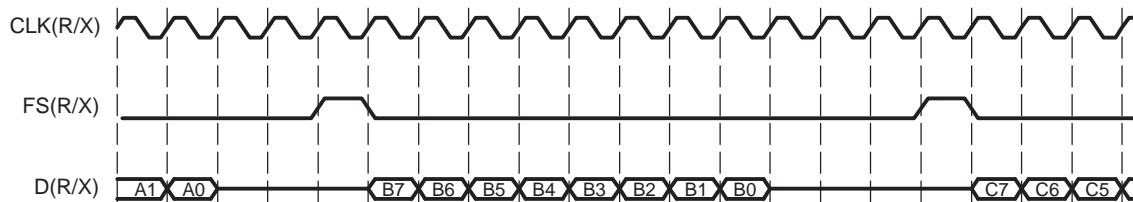

5.1 Receive Operation

Figure 22 shows serial reception. Once the receive frame synchronization signal (FSR) transitions to its active state, it is detected on the first falling edge of the receiver's CLKR. The data on the DR pin is then shifted into the receive shift register (RSR) after the appropriate data delay as set by RDATDLY. The contents of RSR is copied to RBR at the end of every element on the rising edge of the clock, provided RBR is not full with the previous data. Then, an RBR-to-DRR copy activates the RRDY status bit to 1 on the following falling edge of CLKR. This indicates that the receive data register (DRR) is ready with the data to be read by the CPU or the DMA controller. RRDY is deactivated when the DRR is read by the CPU or the DMA controller (see Section 3.2.1).

Figure 22. Receive Operation

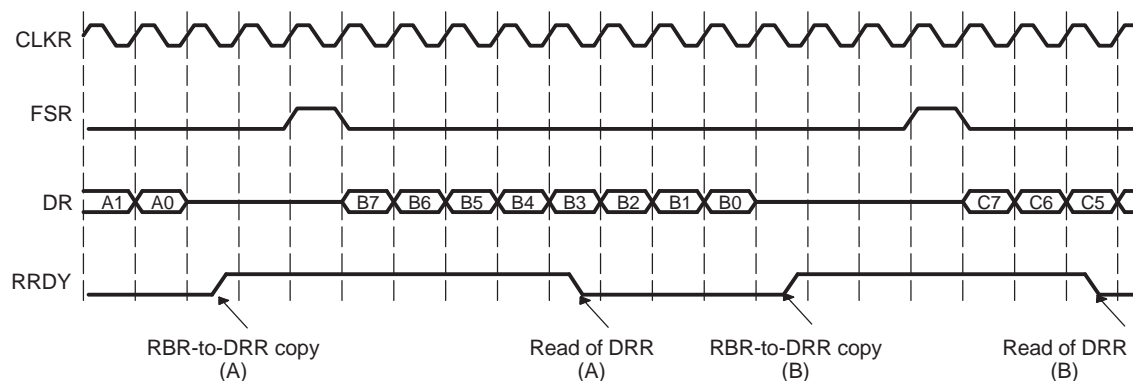

5.2 Transmit Operation

Once transmit frame synchronization occurs, the value in the transmit shift register (XSR) is shifted out and driven on the DX pin after the appropriate data delay as set by XDATDLY. XRDY is activated after every DXR-to-XSR copy on the following falling edge of CLKX, indicating that the data transmit register (DXR) can be written with the next data to be transmitted. XRDY is deactivated when the DXR is written by the CPU or the DMA controller. Figure 23 illustrates serial transmission. For information on transmit operation when the transmitter is pulled out of reset (XRST = 1), see Section 5.5.4 and Section 3.2.2.

Figure 23. Transmit Operation

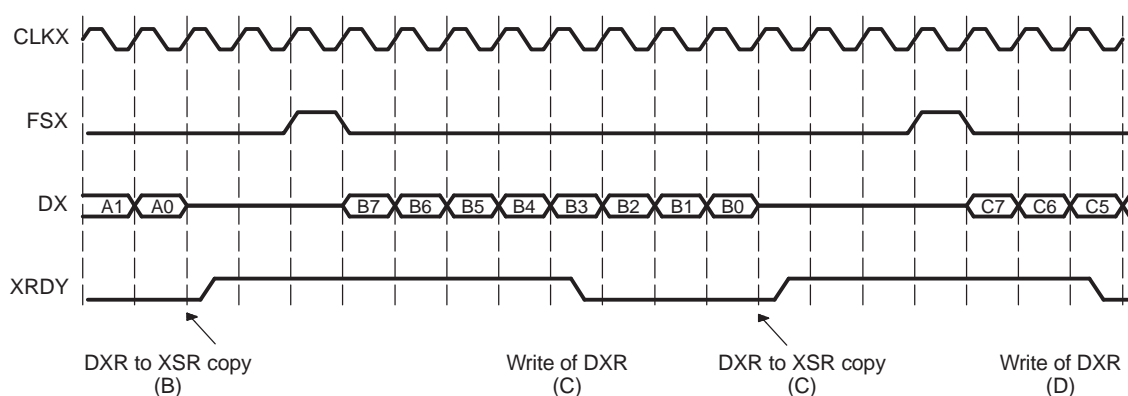

5.3 Maximum Frame Frequency

The frame frequency is determined by the following equation, which calculates the period between frame synchronization signals:

$$\text{Frame frequency} = \frac{\text{Bit-clock frequency}}{\text{Number of bit clocks between frame sync signals}}$$

The frame frequency may be increased by decreasing the time between frame synchronization signals in bit clocks (which is limited only by the number of bits per frame). As the frame transmit frequency is increased, the inactivity period between the data frames for adjacent transfers decreases to 0. The minimum time between frame synchronization pulses is the number of bits transferred per frame. This time also defines the maximum frame frequency, which is calculated by the following equation:

$$\text{Maximum frame frequency} = \frac{\text{Bit-clock frequency}}{\text{Number of bits per frame}}$$

Figure 24 shows the McBSP operating at maximum frame frequency. The data bits in consecutive frames are transmitted continuously with no inactivity between bits. If there is a 1-bit data delay, as shown, the frame synchronization pulse overlaps the last bit transmitted in the previous frame.

Figure 24. Maximum Frame Frequency for Transmit and Receive

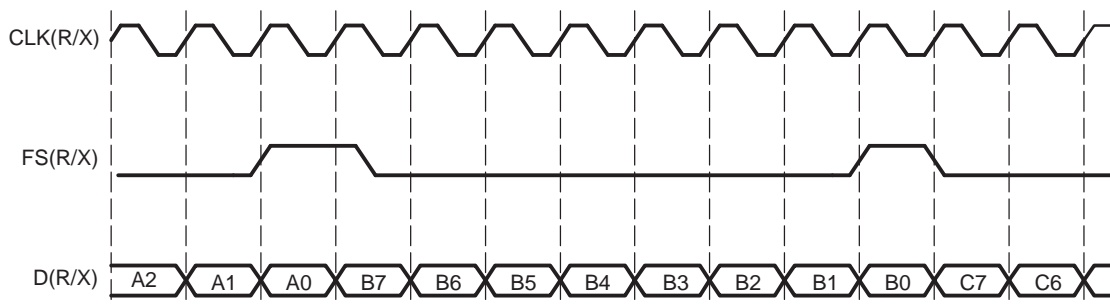

NOTE: For (R/X)DATDLY = 0, the first bit of data transmitted is asynchronous to CLKX, as shown in Figure 13

5.4 Frame Synchronization Ignore

The McBSP can be configured to ignore transmit and receive frame synchronization pulses. The (R/X)FIG bit in (R/X)CR can be cleared to 0 to recognize frame sync pulses, or it can be set to 1 to ignore frame sync pulses. In this way, you can use (R/X)FIG either to pack data, if operating at maximum frame frequency, or to ignore unexpected frame sync pulses.

5.4.1 Frame Sync Ignore and Unexpected Frame Sync Pulses

RFIG and XFIG are used to ignore unexpected internal or external frame sync pulses. Any frame sync pulse is considered unexpected if it occurs one or more bit clocks earlier than the programmed data delay from the end of the previous frame specified by ((R/X)DATDLY). Setting the frame ignore bits to 1 causes the serial port to ignore these unexpected frame sync signals.

In reception, if not ignored (RFIG = 0), an unexpected FSR pulse discards the contents of RSR in favor of the incoming data. Therefore, if RFIG = 0, an unexpected frame synchronization pulse aborts the current data transfer, sets RSYNCERR in SPCR to 1, and begins the reception of a new data element. When RFIG = 1, the unexpected frame sync pulses are ignored.

In transmission, if not ignored (XFIG = 0), an unexpected FSX pulse aborts the ongoing transmission, sets the XSYNCERR bit in SPCR to 1, and reinitiates transmission of the current element that was aborted. When XFIG = 1, unexpected frame sync signals are ignored.

Figure 25 shows that element B is interrupted by an unexpected frame sync pulse when (R/X)FIG = 0. The reception of B is aborted (B is lost), and a new data element (C) is received after the appropriate data delay. This condition causes a receive synchronization error and thus sets the RSYNCERR bit. However, for transmission, the transmission of B is aborted and the same data (B) is retransmitted after the appropriate data delay. This condition is a transmit synchronization error and thus sets the XSYNCERR bit. Synchronization errors are discussed in Section 5.5.2 and Section 5.5.5.

Figure 25. Unexpected Frame Synchronization With (R/X) FIG = 0

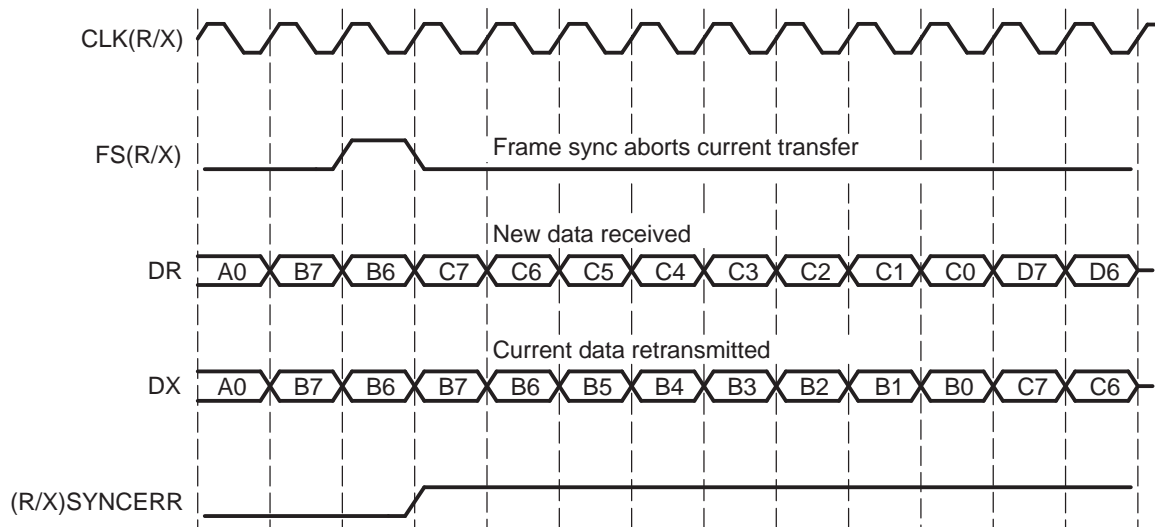
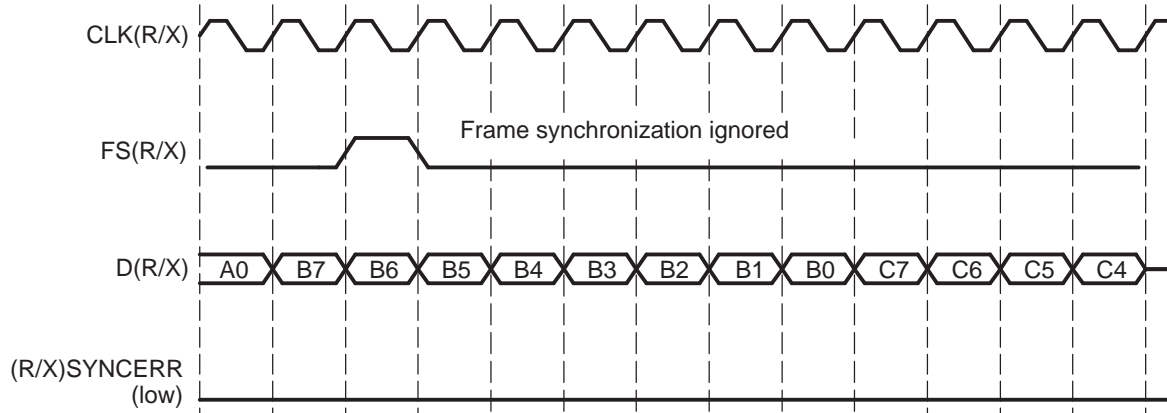

Figure 26 shows McBSP operation when unexpected internal or external frame synchronization signals are ignored by setting (R/X)FIG = 1. Here, the transfer of element B is not affected by an unexpected frame synchronization.

Figure 26. Unexpected Frame Synchronization With (R/X)FIG = 1



5.4.2 Data Packing using Frame Sync Ignore Bits

Section 4.5.4 describes one method of changing the element length and frame length to simulate 32-bit serial element transfers, thus requiring much less bus bandwidth than four 8-bit transfers require. This example works when there are multiple elements per frame. Now consider the case of the McBSP operating at maximum packet frequency, as shown in Figure 27. Here, each frame has only a single 8-bit element. This stream takes one read transfer and one write transfer for each 8-bit element. Figure 28 shows the McBSP configured to treat this stream as a continuous stream of 32-bit elements. In this example, (R/X)FIG is set to 1 to ignore unexpected subsequent frames. Only one read transfer and one write transfer is needed every 32-bits. This configuration effectively reduces the required bus bandwidth to one-fourth of the bandwidth needed to transfer four 8-bit blocks.

Figure 27. Maximum Frame Frequency Operation with 8-Bit Data

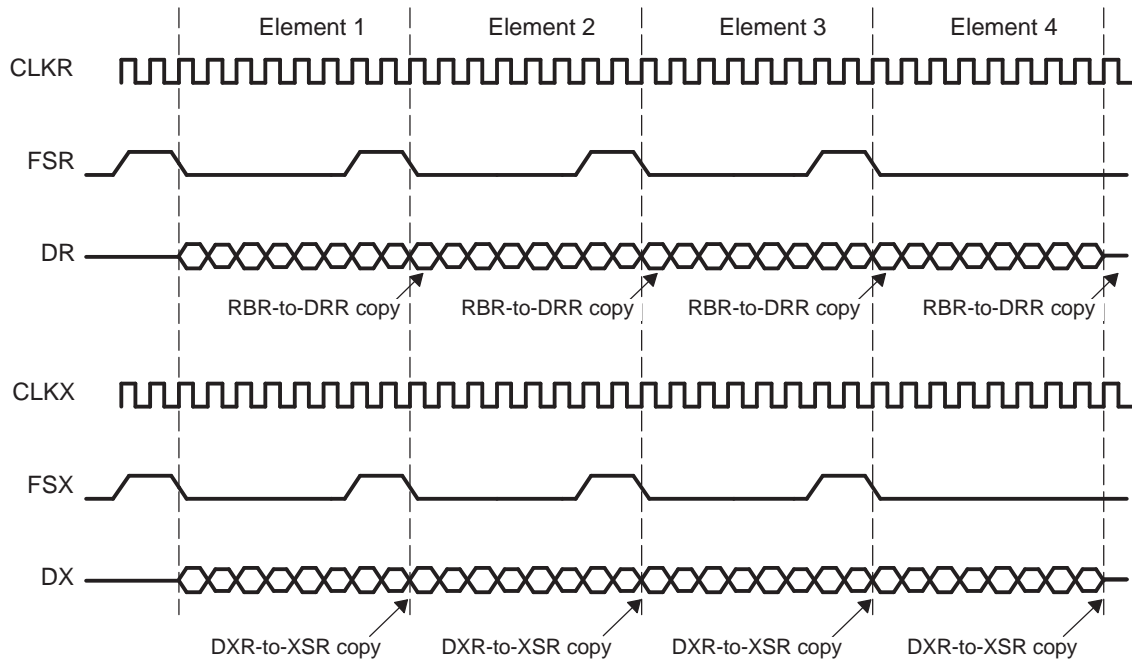
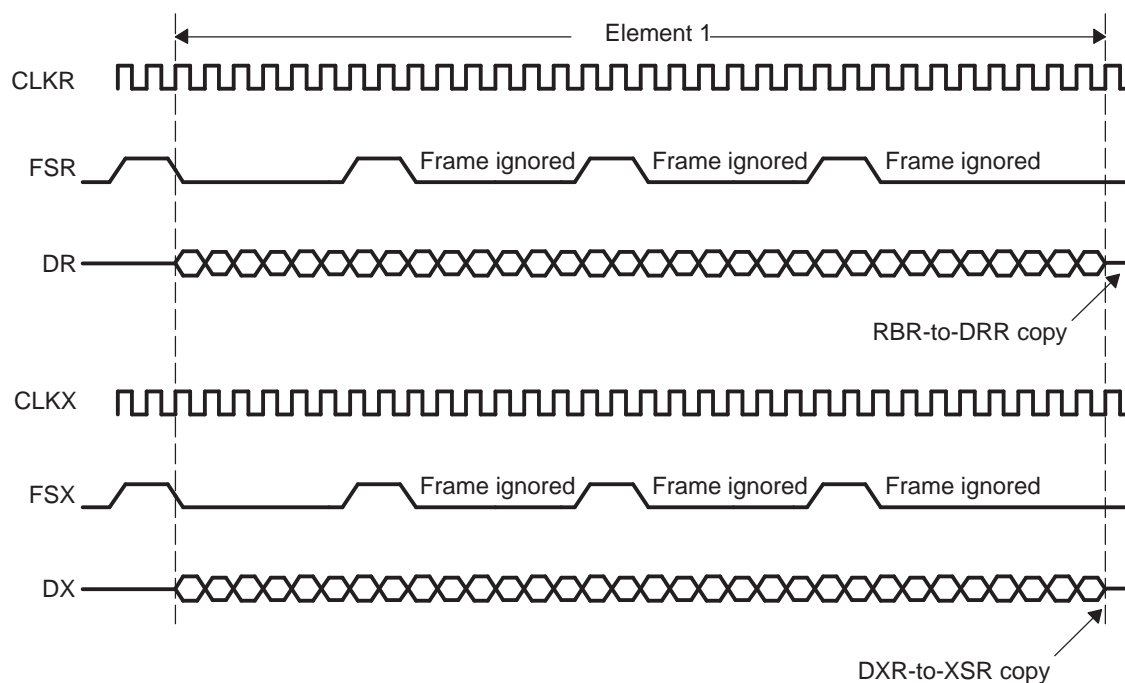

Figure 28. Data Packing at Maximum Frame Frequency With (R/X)FIG = 1

5.5 Serial Port Exception Conditions

There are five serial port events that can constitute a system error:

- Receive overrun (RFULL = 1)
- Unexpected receive frame synchronization (RSYNCERR = 1)
- Transmit data overwrite
- Transmit empty (XEMPTY = 0)
- Unexpected transmit frame synchronization (XSYNCERR = 1)

5.5.1 Receive Overrun: RFULL

RFULL = 1 in SPCR indicates that the receiver has experienced overrun and is in an error condition. RFULL is set when the following conditions are met:

- DRR has not been read since the last RBR-to-DRR transfer.
- RBR is full and an RBR-to-DRR copy has not occurred.
- RSR is full and an RSR-to-RBR transfer has not occurred.

The data arriving on DR is continuously shifted into RSR. Once a complete element is shifted into RSR, an RSR-to-RBR transfer can occur only if an RBR-to-DRR copy is complete. Therefore, if DRR has not been read by the CPU or the DMA controller since the last RBR-to-DRR transfer (RRDY = 1), an RBR-to-DRR copy does not take place until RRDY = 0. This prevents an RSR-to-RBR copy. New data arriving on the DR pin is shifted into RSR, and the previous contents of RSR is lost. After the receiver starts running from reset, a minimum of three elements must be received before RFULL can be set, because there was no last RBR-to-DRR transfer before the first element.

This data loss can be avoided if DRR is read no later than two and a half CLKR cycles before the end of the third element (data C) in RSR, as shown in [Figure 30](#).

Either of the following events clears the RFULL bit and allows subsequent transfers to be read properly:

- Reading DRR
- Resetting the receiver (RRST = 0) or the device

Another frame synchronization is required to restart the receiver.

Figure 29 shows the receive overrun condition. Because element A is not read before the reception of element B is complete, B is not transferred to DRR yet. Another element, C, arrives and fills RSR. DRR is finally read, but not earlier than two and one half cycles before the end of element C. New data D overwrites the previous element C in RSR. If RFULL is still set after the DRR is read, the next element can overwrite D if DRR is not read in time.

Figure 29. Serial Port Overrun

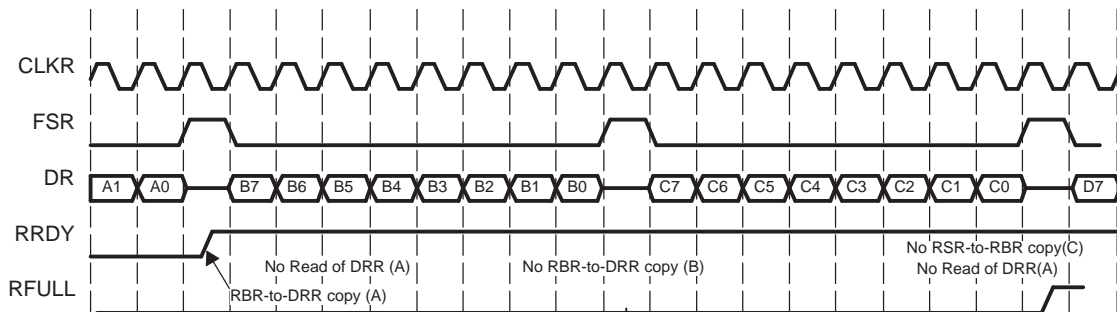
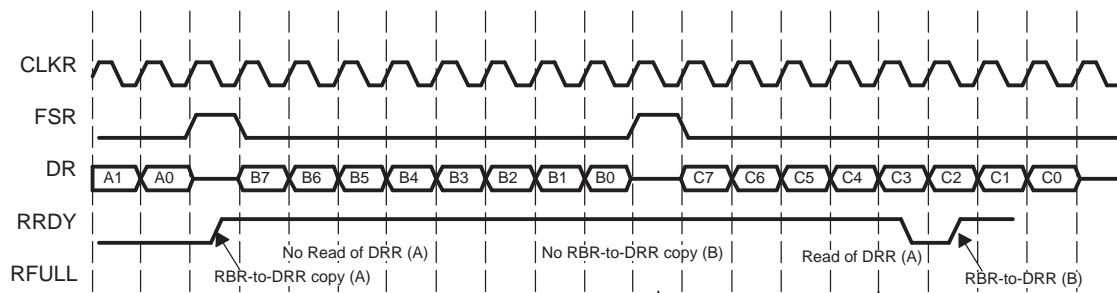

Figure 30 shows the case in which RFULL is set but the overrun condition is averted by reading the contents of DRR at least two and a half cycles before the next element, C, is completely shifted into RSR. This ensures that a RBR-to-DRR copy of data B occurs before the next element is transferred from RSR to RBR.

Figure 30. Serial Port Receive Overrun Avoided



5.5.2 Unexpected Receive Frame Synchronization: RSYNCERR

Figure 31 shows the decision tree that the receiver uses to handle all incoming frame synchronization pulses. The diagram assumes that the receiver has been activated (RRST = 1). Unexpected frame sync pulses can originate from an external source or from the internal sample rate generator. An unexpected frame sync pulse is defined as a sync pulse which occurs RDATDLY bit clocks earlier than the last transmitted bit of the previous frame. Any one of three cases can occur:

- Case 1: Unexpected FSR pulses with RFIG = 1. This case is discussed in Section 5.4.1 and shown in Figure 26. Here, receive frame sync pulses are ignored and the reception continues.
- Case 2: Normal serial port reception. There are three reasons for a receive *not* to be in progress:
 - This FSR is the first after RRST = 1.
 - This FSR is the first after DRR has been read clearing an RFULL condition.
 - The serial port is in the inter-packet intervals. The programmed data delay (RDATDLY) for reception may start during these inter-packet intervals for the first bit of the next element to be received. Thus, at maximum frame frequency, frame synchronization can still be received RDATDLY bit clocks before the first bit of the associated element. Alternatively, the unexpected frame sync pulse is detected when it occurs at or before RDATDLY minus 1 bit clock before the last bit of the previous word is received on the DR pin.

For this case, reception continues normally, because these are not unexpected frame sync pulses.

- Case 3: Unexpected receive frame synchronization with RFIG = 0 (unexpected frame not ignored). This case was shown in Figure 25 for maximum packet frequency. Figure 32 shows this case during normal operation of the serial port with time intervals between packets. Unexpected frame sync pulses

are detected when they occur the value in RDATA bit clocks before the last bit of the previous element is received on DR. In both cases, RSYNCERR in SPCR is set. RSYNCERR can be cleared only by receiver reset or by clearing this bit in SPCR. If RINTM = 1b in SPCR, RSYNCERR drives the receive interrupt (RINT) to the CPU.

NOTE: Note that the RSYNCERR bit in SPCR is a read/write bit, so writing to it sets the error condition. Typically, clearing it is expected.

Figure 31. Decision Tree Response to Receive Frame Synchronization Pulse

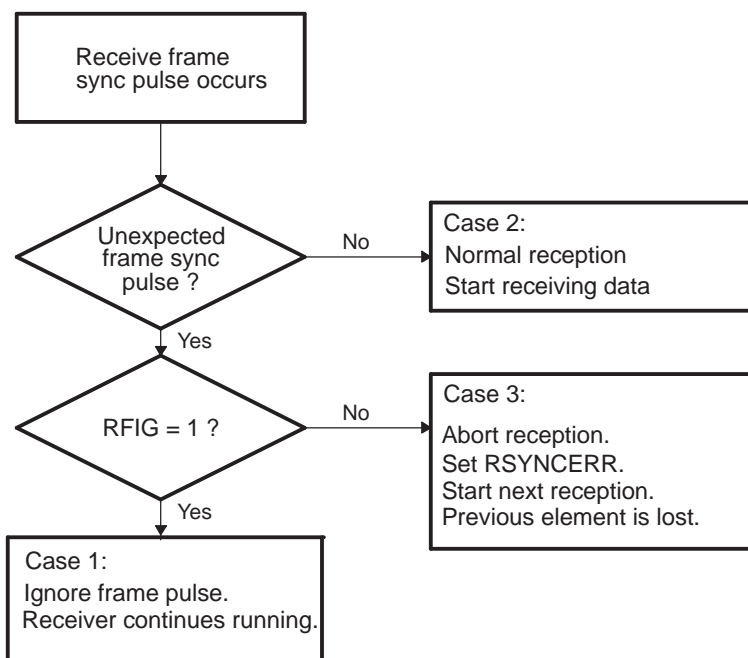
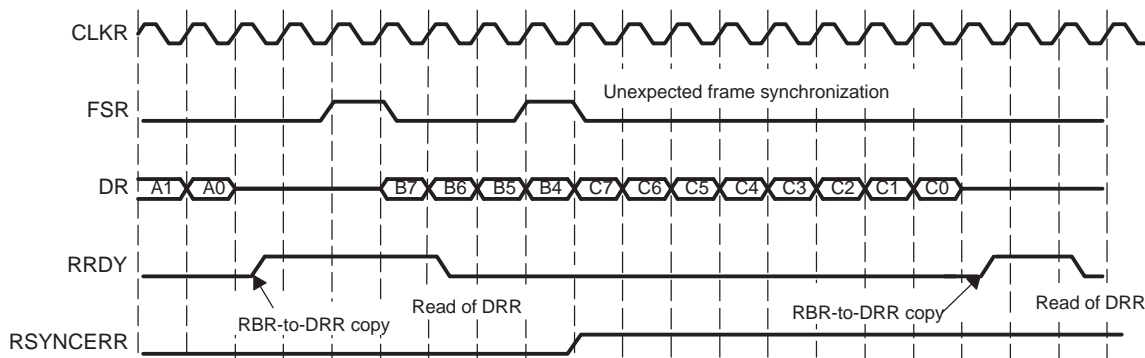

Figure 32. Unexpected Receive Synchronization Pulse



5.5.3 Transmit With Data Overwrite

Figure 33 shows what happens if the data in DXR is overwritten before it is transmitted. Suppose you load the DXR with data C. A subsequent write to the DXR overwrites C with D before C is copied to the XSR. Thus, C is never transmitted on DX. The CPU can avoid overwriting data by polling XRDY before writing to DXR or by waiting for a programmed XINT to be triggered by XRDY (XINTM = 00b). The DMA/EDMA controller can avoid overwriting by synchronizing data writes with XEVT (see the last paragraph in Section 3.2.2).

Figure 33. Transmit With Data Overwrite

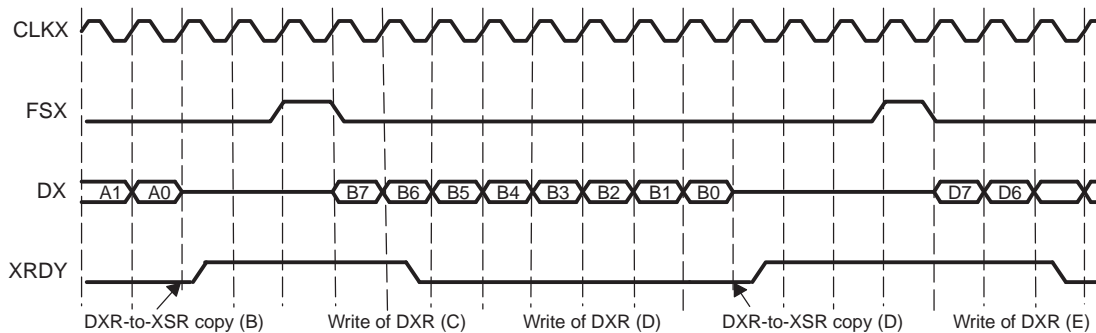

5.5.4 Transmit Empty: XEMPTY

XEMPTY indicates whether the transmitter has experienced under flow. Either of the following conditions causes XEMPTY to become active (XEMPTY = 0):

- During transmission, DXR has not been loaded since the last DXR-to-XSR copy, and all bits of the data element in XSR have been shifted out on DX.
- The transmitter is reset (XRST = 0 or the device is reset), and then restarted.

During underflow condition, the transmitter continues to transmit the old data in DXR for every new frame sync signal FSX (generated by an external device, or by the internal sample rate generator) until a new element is loaded into DXR by the CPU or the DMA/EDMA controller. XEMPTY is deactivated (XEMPTY = 1) when this new element in DXR is transferred to XSR. In the case when the FSX is generated by a DXR-to-XSR copy (FSXM = 1 in PCR and FSGM = 0 in SRGR), the McBSP does not generate any new frame sync until new data is written to the DXR and a DXR-to-XSR copy occurs.

When the transmitter is taken out of reset (XRST = 1), it is in a transmit ready (XRDY = 1) and transmit empty (XEMPTY = 0) condition. If DXR is loaded by the CPU or the DMA controller before FSX goes active, a valid DXR-to-XSR transfer occurs. This allows for the first element of the first frame to be valid even before the transmit frame sync pulse is generated or detected. Alternatively, if a transmit frame sync is detected before DXR is loaded, 0s are output on DX.

Figure 34 shows a transmit underflow condition. After B is transmitted, B is retransmitted on DX if you fail to reload the DXR before the subsequent frame synchronization. Figure 35 shows the case of writing to DXR just before a transmit underflow condition that would otherwise occur. After B is transmitted, C is written to DXR before the next transmit frame sync pulse occurs.

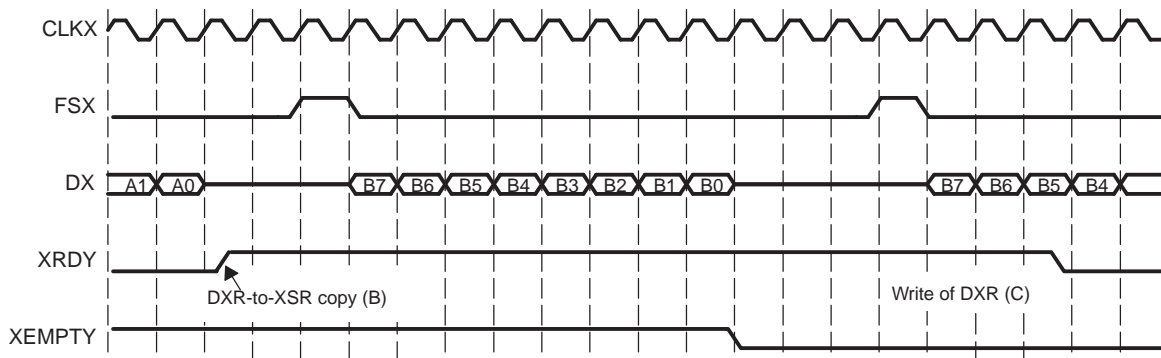
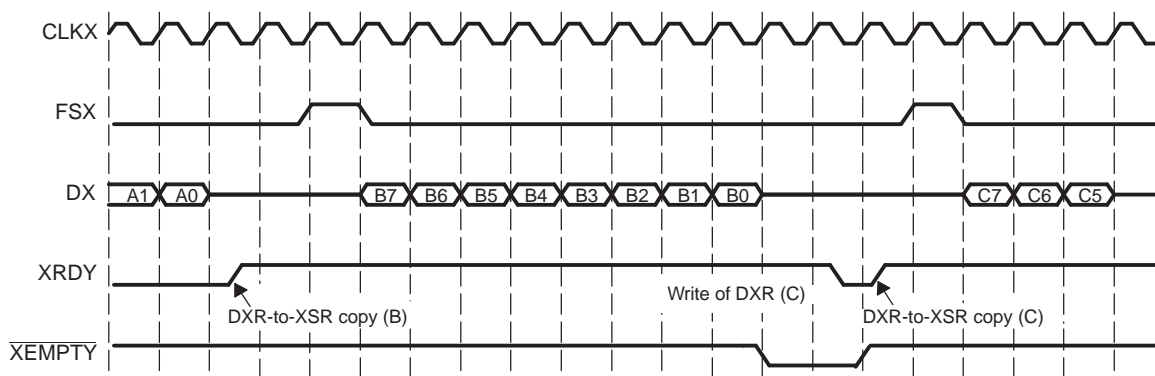
Figure 34. Transmit Empty

Figure 35. Transmit Empty Avoided

5.5.5 Unexpected Transmit Frame Synchronization: XSYNCERR

A transmit frame sync error (XSYNCERR) may occur the first time the transmitter is enabled (XRST = 1) after a device reset. To avoid this, after enabling the transmitter for the first time, the following procedure must be followed:

1. Wait for two CLKG cycles. The unexpected frame sync error (XSYNCERR), if any, occurs within this time period.
2. Disable the transmitter (XRST = 0). This clears any XSYNCERR.
3. Reenable the transmitter (XRST = 1).

For details on initialization procedure, see [Section 7](#).

[Figure 36](#) shows the decision tree that the transmitter uses to handle all incoming frame synchronization signals. The diagram assumes that the transmitter has been started (XRST = 1). An unexpected transmit frame sync pulse is defined as a sync pulse that occurs XDATDLY bit clocks earlier than the last transmitted bit of the previous frame. Any one of three cases can occur:

- Case 1: Unexpected FSX pulses with XFIG = 1. This case is discussed in [Section 5.4.1](#) and shown in [Figure 26](#). In this case, unexpected FSX pulses are ignored, and the transmission continues.
- Case 2: FSX pulses with normal serial port transmission. This situation is discussed in [Section 5.3](#). There are two possible reasons for a transmit *not* to be in progress:
 - This FSX pulse is the first one to occur after XRST = 1.
 - The serial port is in the interpacket intervals. The programmed data delay (XDATDLY) may start during these interpacket intervals before the first bit of the next element is transmitted. Thus, if operating at maximum packet frequency, frame synchronization can still be received XDATDLY bit clocks before the first bit of the associated element.
- Case 3: Unexpected transmit frame synchronization with XFIG = 0. The case for frame synchronization with XFIG = 0 at maximum packet frequency is shown in [Figure 25](#). [Figure 37](#) shows the case for normal operation of the serial port with interpacket intervals. In both cases, XSYNCERR in SPCR is

set. XSYNCERR can be cleared only by transmitter reset or by clearing this bit in SPCR. If XINTM = 11b in SPCR, XSYNCERR drives the receive interrupt (XINT) to the CPU.

NOTE: The XSYNCERR bit in SPCR is a read/write bit, so writing to it sets the error condition. Typically, clearing it is expected.

Figure 36. Decision Tree Response to Transmit Frame Synchronization Pulse

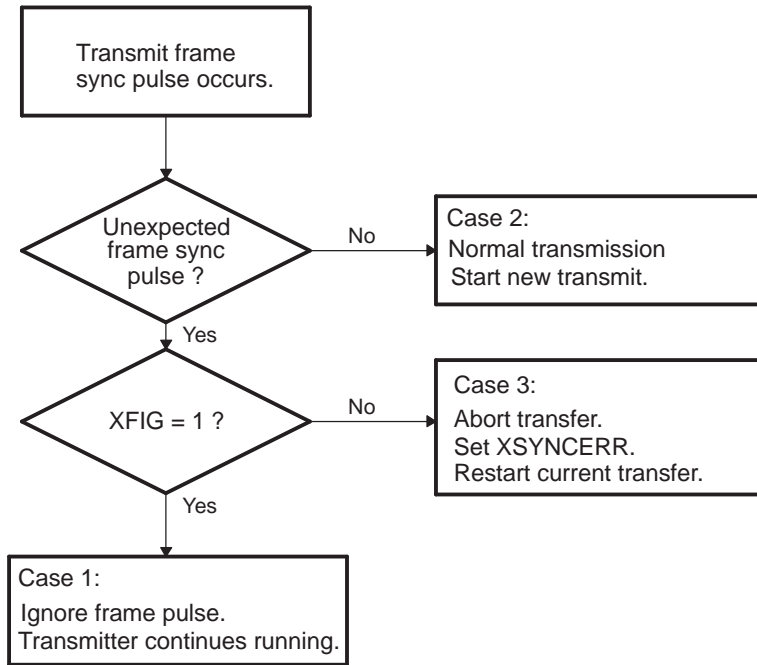
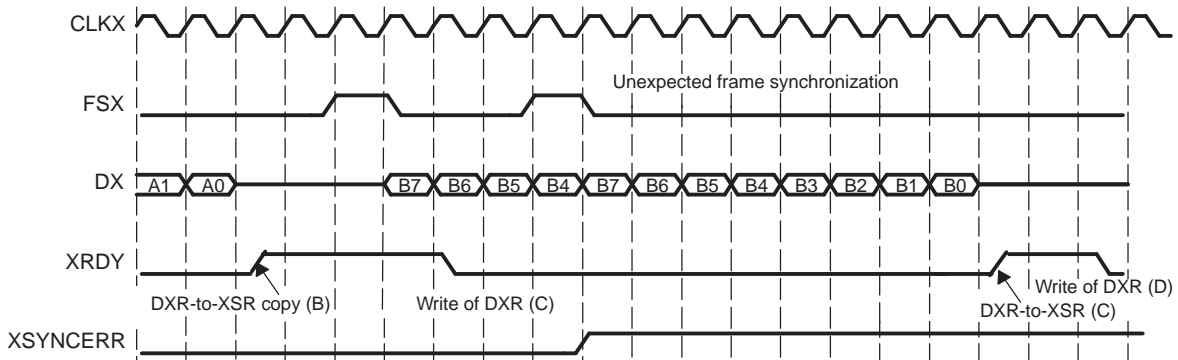

Figure 37. Unexpected Transmit Frame Synchronization Pulse



6 μ-Law/A-Law Companding Hardware Operation

Companding (*compressing* and *expanding*) hardware allows compression and expansion of data in either μ-law or A-law format. The specification for μ-law and A-law log PCM is part of the CCITT G.711 recommendation. The companding standard employed in the United States and Japan is μ-law and allows 14 bits of dynamic range. The European companding standard is A-law and allows 13 bits of dynamic range. Any values outside these ranges are set to the most positive or most negative value. Thus, for companding to work best here, the data transferred to and from the McBSP via the CPU or the DMA controller must be at least 16 bits wide.

The μ-law and A-law formats encode data into 8-bit code elements. Companded data is always 8-bits-wide, so the appropriate (R/X)WDLEN1/2 must be cleared to 0, indicating an 8-bit serial data stream. If companding is enabled and either phase of the frame does not have an 8-bit element length, companding continues as if the element length is eight bits.

When companding is used, transmit data is encoded according to the specified companding law, and receive data is decoded to 2s-complement format. Companding is enabled and the desired format is selected by appropriately setting (R/X) COMPAND in the (R/X)CR, as indicated in Table 20 and Table 21. Compression occurs during the process of copying data from DXR to XSR and expansion occurs from RBR to DRR, as shown in Figure 38.

For transmit data to be compressed, it should be 16-bit, left-justified data, such as LAW16, as shown in Figure 39. The value can be either 13 or 14 bits wide, depending on the companding law. This 16-bit data is aligned in DXR, as shown in Figure 40.

For reception, the 8-bit compressed data in RBR is expanded to a left-justified 16-bit data, LAW16. This can be further justified to 32-bit data by programming the RJUST bits in SPCR, as shown in Table 12.

Figure 38. Companding Flow

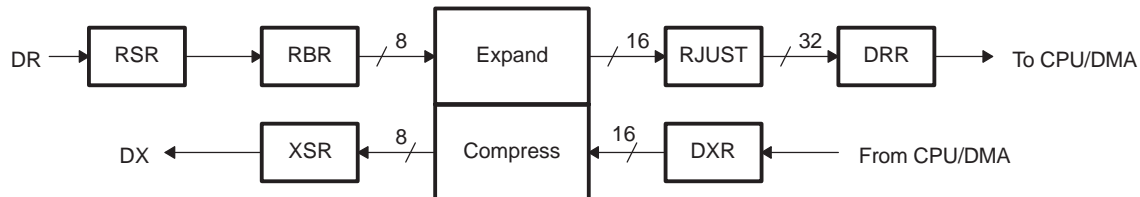

Figure 39. Companding Data Formats

| | | | | |
|-------|-------|---|---|---|
| LAW16 | 15 | 2 | 1 | 0 |
| μ-Law | Value | | 0 | |
| LAW16 | 15 | 3 | 2 | 0 |
| A-law | Value | | 0 | |

Figure 40. Transmit Data Companding Format in DXR



Table 12. Justification of Expanded Data in DRR

| RJUST | DRR Bits | |
|-------|----------|-------|
| | 31-16 | 15-0 |
| 00 | 0 | LAW16 |
| 01 | sign | LAW16 |
| 10 | LAW16 | 0 |
| 11 | Reserved | |

6.1 Companding Internal Data

If the McBSP is unused, the companding hardware can compand internal data. This hardware can be used to:

- Convert linear data to the appropriate μ -law or A-law format.
- Convert μ -law or A-law data to the linear format.
- Observe the quantization effects in companding by transmitting linear data and compressing and re-expanding this data. This is useful only if both XCOMPAND and RCOMPAND enable the same companding format.

Figure 41 shows the method by which the McBSP can compand internal data for the C6474 device.

DLB: The McBSP is enabled in digital loopback (DLB) mode with companding appropriately enabled by the RCOMPAND and XCOMPAND bits. Receive and transmit interrupts (RINT when RINTM = 0 and XINT when XINTM = 0) or synchronization events (REVT and XEVT) allow synchronization of the CPU or the DMA/EDMA controller to these conversions, respectively. Here, the time for this companding depends on the serial bit rate selected.

Figure 41. Companding of Internal Data

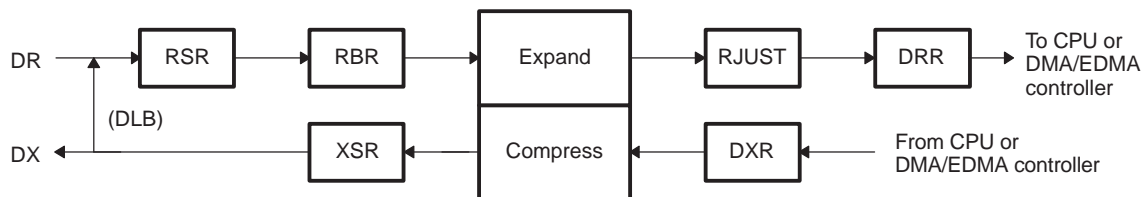

6.2 Bit Ordering

Normally, all transfers on the McBSP are sent and received with the MSB first. However, certain 8-bit data protocols (that do not use companded data) require the LSB to be transferred first. By setting the (R/X)COMPAND = 01b in (R/X)CR, the bit ordering of 8-bit elements is reversed (LSB first) before being sent to the serial port. Like the companding feature, this feature is enabled only if the appropriate (R/X)WDLEN1/2 bit is cleared to 0, indicating that 8-bit elements are to be serially transferred.

7 McBSP Initialization Procedure

The McBSP initialization procedure varies depending on the specific system setup. [Section 7.1](#) provides a general initialization sequence. [Section 7.2](#) provides an initialization sequence for the special case when the external device provides the transmit frame sync FSX (FSXM = 0).

The transmitter and the receiver of the McBSP can operate independently from each other. Therefore, they can be placed in or taken out of reset individually by modifying only the desired bit in the registers without disrupting the other portion. The steps in the following sections discuss the initialization procedure for taking both the transmitter and the receiver out of reset. To initialize only one portion, configure only the portion desired.

The McBSP internal sample rate generator and internal frame sync generator are shared between the transmitter and the receiver. [Table 13](#) and [Table 14](#) describe their usage base upon the clock and frame sync configurations of the receiver and transmitter, respectively.

Table 13. Receiver Clock and Frame Configurations

| CLKR Source | FSR Source | Comment on Configuration |
|-------------|------------|---|
| Internal | Internal | The McBSP internal sample rate generator and internal frame sync generator are used by the receiver. |
| External | Internal | Invalid configuration for receiver. |
| Internal | External | The McBSP internal sample rate generator is used but the internal frame sync generator is not used by the receiver. |
| External | External | The McBSP internal sample rate generator and internal frame sync generator are not used by the receiver. |

Table 14. Transmitter Clock and Frame Configurations

| CLKX Source | FSX Source | Comment on Configuration |
|-------------|------------|--|
| Internal | Internal | The McBSP internal sample rate generator is used by the transmitter. The transmitter can generate frame sync FSX in one of two ways. First, it can generate FSX by using the internal frame sync generator (FSGM = 1). Alternatively, it can generate FSX upon each DXR-to-XSR copy (FSGM = 0). In this case, the internal frame sync generator can be kept in reset (FRST = 0) if it is not used by the receiver. You can follow the general initialization sequence in Section 7.1 . |
| External | Internal | The McBSP internal sample rate generator and internal frame sync generator are not used by the transmitter. This configuration is only valid with FSGM = 0 where the McBSP transmitter generates FSX upon each DXR-to-XSR copy. You can follow the general initialization sequence in Section 7.1 . |
| Internal | External | The McBSP internal sample rate generator is used by the transmitter but the internal frame sync generator is not. You should follow the special initialization sequence for McBSP as transmit frame sync master in Section 7.2 . |
| External | External | The McBSP internal sample rate generator and internal frame sync generator are not used by the transmitter. You should follow the special initialization sequence for McBSP as transmit frame sync master in Section 7.2 . |

7.1 General Initialization Procedure

This section provides the general initialization procedure. For the special case when the transmitter is used and the transmit frame sync FSX is provided by the external device, see [Section 7.2](#).

1. Ensure that no portion of the McBSP is using the internal sample rate generator signal CLKG and the internal frame sync generator signal FSG (GRST = FRST = 0). The respective portion of the McBSP needs to be in reset (XRST = 0 and/or RRST = 0).
2. Program the control registers as required. Ensure the internal sample rate generator and the internal frame sync generator are still in reset (GRST = FRST = 0). Also ensure the respective portion of the McBSP is still in reset in this step (XRST = 0 and/or RRST = 0).
3. Wait for proper internal synchronization. If the external device provides the bit clock, wait for two CLKR or CLKX cycles. If the McBSP generates the bit clock as a clock master, wait for two CLKSRG cycles. In this case, the clock source to the sample rate generator (CLKSRG) is selected by the CLKSM bit in SRGR.

4. Skip this step if the bit clock is provided by the external device. This step only applies if the McBSP is the bit clock master and the internal sample rate generator is used.
 - (a) Start the sample rate generator by setting the GRST bit to 1. Wait two CLKG bit clocks for synchronization. CLKG is the output of the sample rate generator.
 - (b) On the next rising edge of CLKSRG, CLKG transitions to 1 and starts clocking with a frequency equal to $1/(CLKGDV + 1)$ of the sample rate generator source clock CLKSRG.
5. Skip this step if the transmitter is not used. If the transmitter is used, a transmit sync error (XSYNCERR) may occur when it is enabled for the first time after device reset. The purpose of this step is to clear any potential XSYNCERR that occurs on the transmitter at this time:
 - (a) Set the XRST bit to 1 to enable the transmitter.
 - (b) Wait for any unexpected frame sync error to occur. If the external device provides the bit clock, wait for two CLKR or CLKX cycles. If the McBSP generates the bit clock as a clock master, wait for two CLKG cycles. The unexpected frame sync error (XSYNCERR), if any, occurs within this time period.
 - (c) Disable the transmitter (XRST = 0). This clears any outstanding XSYNCERR.
6. Setup data acquisition as required:
 - (a) If the DMA/EDMA controller is used to service the McBSP, setup data acquisition as desired and start the DMA/EDMA controller in this step, before the McBSP is taken out of reset.
 - (b) If CPU interrupt is used to service the McBSP, enable the transmit and/or receive interrupt as required.
 - (c) If CPU polling is used to service the McBSP, no action is required in this step.
7. Set the XRST bit and/or the RRST bit to 1 to enable the corresponding section of the McBSP. The McBSP is now ready to transmit and/or receive.
 - (a) If the DMA/EDMA controller is used to service the McBSP, it services the McBSP automatically upon receiving the XEVT and/or REVT.
 - (b) If CPU interrupt is used to service the McBSP, the interrupt service routine is automatically entered upon receiving the XINT and/or RINT.
 - (c) If CPU polling is used to service the McBSP, it can do so now by polling the XRDY and/or RRDY bit.
8. If the internal frame sync generator is used (FSGM = 1), proceed to the additional steps to turn on the internal frame sync generator. Initialization is complete if any one of the following is true:
 - (a) The external device generates frame sync FSX and/or FSR. The McBSP is now ready to transmit and/or receive upon receiving external frame sync.
 - (b) The McBSP generates transmit frame sync FSX upon each DXR-to-XSR copy. The internal frame sync generator is not used (FSGM = 0).

Additional steps to turn on the internal frame sync generator (only applies if FSGM = 1):
9. Skip this step if the transmitter is not used. If the transmitter is used, ensure that DXR is serviced before you start the internal frame sync generator. You can do so by checking XEMPTY = 1 (XSR is not empty) in SPCR.
10. Set the FRST bit to 1 to start the internal frame sync generator. The internal frame sync signal FSG is generated on a CLKG active edge after 7 to 8 CLKG clocks have elapsed.

7.2 Special Case: External Device is the Transmit Frame Master

Care must be taken if the transmitter expects a frame sync from an external device. After the transmitter comes out of reset ($XRST = 1$), it waits for a frame sync from the external device. If the first frame sync arrives very shortly after the transmitter is enabled, the CPU or DMA/EDMA controller may not have a chance to service DXR. In this case, the transmitter shifts out the default data in XSR instead of the desired value, which has not yet arrived in DXR. This causes problems in some applications, as the first data element in the frame is invalid. The data stream appears element-shifted (the first data word may appear in the second channel instead of the first).

To ensure proper operation when the external device is the frame master, you must assure that DXR is already serviced with the first word when a frame sync occurs. To do so, you can keep the transmitter in reset until the first frame sync is detected. Upon detection of the first frame sync, the McBSP generates an interrupt to the CPU. Within the interrupt service routine, the transmitter is taken out of reset ($XRST = 1$). This assures that the transmitter does not begin data transfers at the data pin during the first frame sync period. This also provides almost an entire frame period for the DSP to service DXR with the first word before the second frame sync occurs. The transmitter only begins data transfers upon receiving the second frame sync. At this point, DXR is already serviced with the first word.

The interrupt service routine must first be setup according to the description in . Then follow this modified procedure for proper initialization:

1. Ensure that no portion of the McBSP is using the internal sample rate generator signal CLKG and the internal frame sync generator signal FSG ($GRST = FRST = 0$). The respective portion of the McBSP needs to be in reset ($XRST = 0$ and/or $RRST = 0$).
2. Program SRGR and other control registers as required. Ensure the internal sample rate generator and the internal frame sync generator are still in reset ($GRST = FRST = 0$). Also ensure the respective portion of the McBSP is still in reset in this step ($XRST = 0$ and/or $RRST = 0$).
3. Program the XINTM bits to 2h in SPCR to generate an interrupt to the CPU upon detection of a transmit frame sync. Do not enable the XINT interrupt in the interrupt enable register (IER) in this step.
4. Wait for proper internal synchronization. If the external device provides the bit clock, wait for two CLKR or CLKX cycles. If the McBSP generates the bit clock as a clock master, wait for two CLKSRG cycles. In this case, the clock source to the sample rate generator (CLKSRG) is selected by the CLKSM bit in SRGR.
5. Skip this step if the bit clock is provided by the external device. This step only applies if the McBSP is the bit clock master and the internal sample rate generator is used.
 - (a) Start the sample rate generator by setting the GRST bit to 1. Wait two CLKG bit clocks for synchronization. CLKG is the output of the sample rate generator.
 - (b) On the next rising edge of CLKSRG, CLKG transitions to 1 and starts clocking with a frequency equal to $1/(\text{CLKGDV} + 1)$ of the sample rate generator source clock CLKSRG.
6. A transmit sync error (XSYNCERR) may occur when it is enabled for the first time after device reset. The purpose of this step is to clear any potential XSYNCERR that occurs on the transmitter at this time:
 - (a) Set the XRST bit to 1 to enable the transmitter.
 - (b) Wait for any unexpected frame sync error to occur. If the external device provides the bit clock, wait for two CLKR or CLKX cycles. If the McBSP generates the bit clock as a clock master, wait for two CLKG cycles. The unexpected frame sync error (XSYNCERR), if any, occurs within this time period.
 - (c) Disable the transmitter ($XRST = 0$). This clears any outstanding XSYNCERR.
7. Setup data acquisition as required:
 - (a) If the DMA/EDMA controller is used to service the McBSP, setup data acquisition as desired and start the DMA/EDMA controller in this step, before the McBSP is taken out of reset.
 - (b) If CPU interrupt is used to service the McBSP, no action is required in this step.
 - (c) If CPU polling is used to service the McBSP, no action is required in this step.

8. Enable the XINT interrupt by setting the corresponding bit in the interrupt enable register (IER). In this step, the McBSP transmitter is still in reset. Upon detection of the first transmit frame sync from the external device, the McBSP generates an interrupt to the CPU and the DSP enters the interrupt service routine (ISR). The ISR needs to perform these tasks in this order:
 - (a) Modify the XINTM bits to the value desired for normal McBSP operations. If CPU interrupt is used to service the McBSP in normal operations, ensure that the XINTM bits are modified to 0 to detect the McBSP XRDY event. If no McBSP interrupt is desired in normal operations, disable future McBSP-to-CPU interrupt in the interrupt enable register (IER).
 - (b) Set the XRST bit and/or the RRST bit to 1 to enable the respective portion of the McBSP. The McBSP is now ready to transmit and/or receive
9. Service the McBSP:
 - (a) If CPU polling is used to service the McBSP in normal operations, it can do so upon exit from the ISR.
 - (b) If CPU interrupt is used to service the McBSP in normal operations, upon XRDY interrupt service routine is entered. The ISR should be setup to verify that XRDY = 1 and service the McBSP accordingly.
 - (c) If DMA/EDMA controller is used to service the McBSP in normal operations, it services the McBSP automatically upon receiving the XEVT and/or REVT.
10. Upon detection of the second frame sync, DXR is already serviced and the transmitter is ready to transmit the valid data. The receiver is also serviced properly by the DSP.

8 Multichannel Selection Operation

The multichannel selection mode allows the McBSP to select independent channels (elements) for transmit and receive in a single-phase frame. Each frame represents a time-division multiplexed data stream. For all of the McBSP, up to 32 elements in a bit stream of up to 128 elements can be enabled at any given time. The C6474 McBSP is an enhanced version that can also select up to 128 elements at any given time (see [Section 8.5](#)).

If a receive element is not enabled:

- RRDY is not set to 1 upon reception of the last bit of the element.
- RBR is not copied to DRR upon reception of the last bit of the element. Thus, RRDY is not set active. This feature also implies that no interrupts or synchronization events are generated for this element.

If a transmit element is not enabled:

- DX is in the high impedance state.
- A DXR-to-XSR transfer is not automatically triggered at the end of serial transmission of the related element.
- XEMPTY and XRDY are not affected by the end of transmission of the related serial element.

An enabled transmit element can have its data masked or transmitted. When data is masked, the DX pin is forced to the high-impedance state even though the transmit channel is enabled.

The following control registers are used in multichannel operation:

- The multichannel control register (MCR)
- The transmit channel enable register (XCER)
- The receive channel enable register (RCER)

NOTE: For C6474 DSPs, RCER and XCER are replaced by RCER0 and XCERE0, respectively. Additional registers XCERE1, XCERE2, XCERE3, RCERE1, RCERE2, and RCERE3 are also used in this mode.

8.1 Enabling Multichannel Selection

Multichannel mode can be enabled independently for reception and transmission by setting the RMCM bit to 1 and the XMCM bit to a nonzero value in MCR, respectively.

8.2 Enabling and Masking of Channels in Normal Multichannel Selection Mode

This section describes how to enable the channels in normal multichannel selection mode. For the enhanced multichannel selection mode of the C6474 DSPs, see [Section 8.5](#).

For all C6000 devices, a total of 32 of the available 128 elements can be enabled at any given time. The 128 elements comprise eight subframes (0 through 7), and each subframe has 16 contiguous elements. Even-numbered subframes 0, 2, 4, and 6 belong to partition A; odd-numbered subframes 1, 3, 5, and 7 belong to partition B.

The number of elements enabled can be updated during the course of a frame to allow any arbitrary group of elements to be enabled. This update is accomplished using an alternating ping-pong scheme for controlling two subframes (one odd-numbered and the other even-numbered) of 16 contiguous elements within a frame at any time. One subframe belongs to partition A and the other to partition B.

Any one 16-element block from partition A and partition B can be selected, yielding a total of 32 elements that can be enabled at one time. The subframes are allocated on 16-element boundaries within the frame, as shown in [Figure 42](#). The (R/X)PABLK and (R/X)PBBLK fields in MCR select the subframes in partition A and B, respectively. This enabling is performed independently for transmit and receive.

Figure 42. Element Enabling by Subframes in Partitions A and B

| Subframe # | 0 | 1 | 2 | 3 | 4 | 5 | 6 | 7 | 0 |
|---------------------------------------|--|------------|------------|------------|------------|------------|-------------|--------------|-----------|
| (R/X)PABLK Partition A elements | 0 0-15 | | 1 32-47 | | 2 64-79 | | 3 96-111 | | 0 0-15 |
| (R/X)PBBLK Partition B elements | | 0 16-31 | | 1 48-63 | | 2 80-95 | | 3 112-127 | |
| FS(R/X) |  | | | | | | | | |

Transmit data masking allows an element enabled for transmit to have its DX pin set to the high-impedance state during its transmit period. In systems where symmetric transmit and receive provides software benefits, this feature allows transmit elements to be disabled on a shared serial bus. A similar feature is not needed for receive, because multiple receptions cannot cause serial bus contention.

NOTE: DX is masked or driven to the high-impedance state:

- During inter-packet intervals.
- When an element is masked regardless of whether it is enabled.
- When an element is disabled.

Following are descriptions of how each XMCM bit value affects operation in normal multichannel selection mode:

- XMCM = 00b: The serial port transmits data over the DX pin for the number of elements programmed in XFRLEN1. Thus, DX is driven during transmit.
- XMCM = 01b: Only those elements that need to be transmitted are selected via XP[A/B]BLK and XCER. Only these selected elements are written to DXR and ultimately transmitted. In other words, if XINTM = 00b, which implies that an XINT is generated for every DXR-to-XSR copy, the number of XINT generated is equal to the number of elements selected via XCER (and *not* equal to XFRLEN1).
- XMCM = 10b: All elements are enabled, which means all the elements in a data frame (XFRLEN1) are written to DXR and DXR-to-XSR copies occur at their respective times. However, DX is driven only for those elements that are selected via XP[A/B]BLK and XCER; otherwise, it is placed in the high-impedance state. In this case, if XINTM = 00b, the number of interrupts generated due to every DXR-to-XSR copy would equal the number of elements in that frame (XFRLEN1).
- XMCM = 11b: This mode is a combination of the XMCM = 01b and 10b cases. In this mode, symmetric transmit and receive operation is forced. Select desired receive channels by setting RCER[A/B]. Symmetric operation occurs when a device transmits and receives on the same set of subframes. These subframes are determined by setting RP[A/B]BLK. The elements in each of these subframes can then be enabled/selected using RCER for receive. The transmit side uses the same blocks as the receive side (thus the value of X(P/A)BLK does not matter). In this mode, all elements are disabled, so DR and DX are in the high-impedance state. For receiving, an RBR-to-DRR copy occurs only for those elements that are selected via RP(A/B)BLK and RCER. If RINT were to be generated for every RBR-to-DRR copy, it would occur as many times as the number of elements selected in RCER (and *not* the number of elements programmed in RFRLEN1). For transmitting, the same subframe that is used for reception is used to maintain symmetry, so the value XP[A/B]BLK does not matter. DXR is loaded, and DXR-to-XSR copy occurs for all the elements that are enabled via RP[A/B]BLK. However, DX is driven only for those elements that are selected via XCER. The elements enabled in XCER can be either a subset of, or the same as, those selected in RCER. Therefore, if XINTM = 00b, transmit interrupts to the CPU would be generated the same number of times as the number of elements selected in RCER (not XCER).

The following four figures show the activity on the McBSP pins for all of the preceding XMCM bit values with the following conditions:

- (R/X)PHASE = 0: Single-phase frame for multichannel selection enabled
- FRLLEN1 = 011b: 4-element frame
- WDLEN1 = Any valid serial element length

In the following illustrations, the arrows indicating the occurrence of events are only sample indications.

Figure 43. XMCM = 00b FOR XMCM Operation

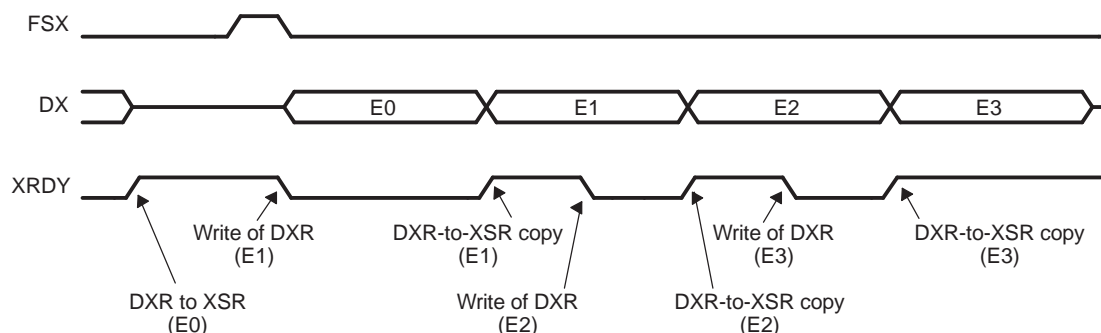

Figure 44. XMCM = 01b, XPABLK = 00b, XCER = 1010b for XMCM Operation

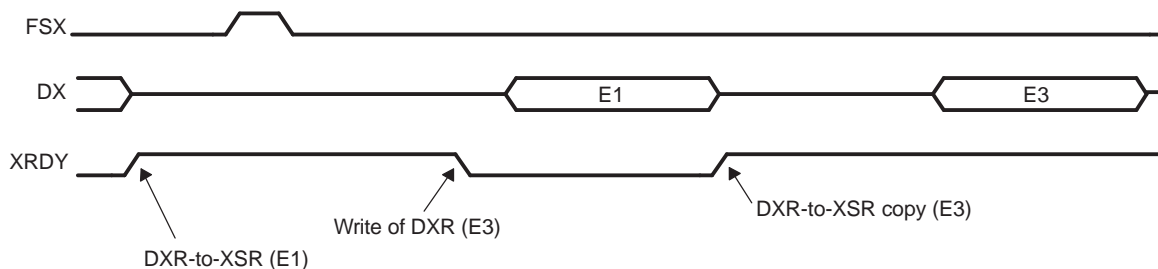

Figure 45. XMCM = 10b, XPABLK = 00b, XCER = 1010b for XMCM Operation

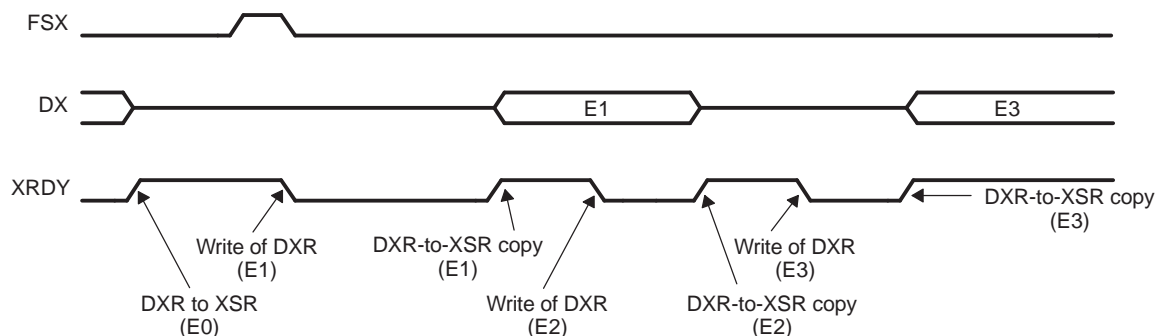
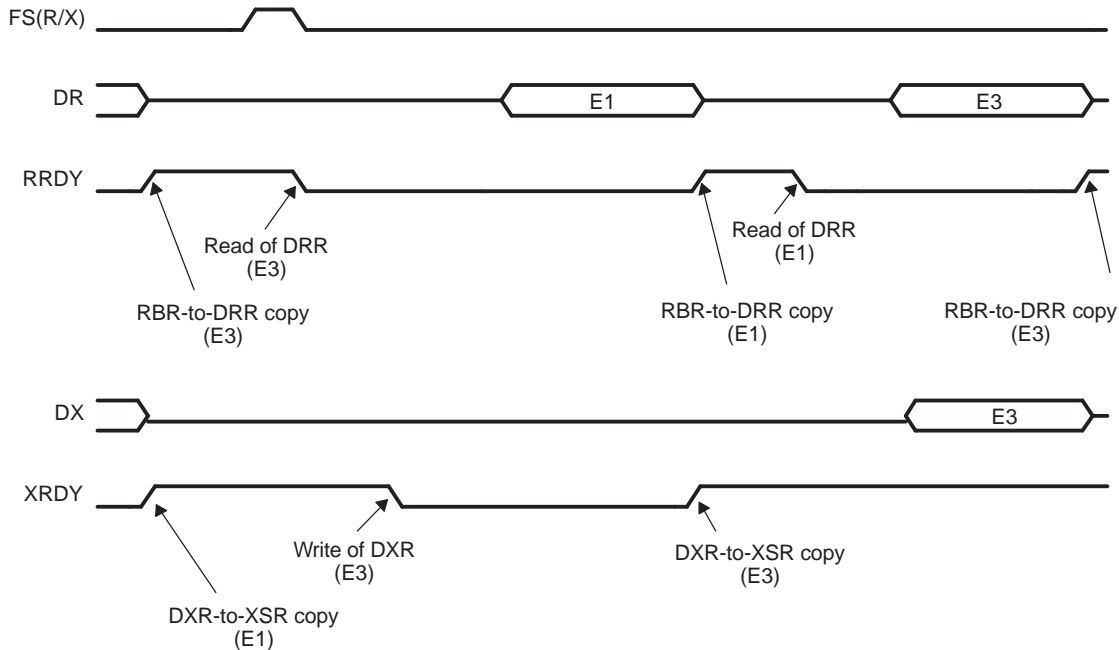

Figure 46. XMCM = 11b, RPABLK = 00b, XPABLK = X, RCER = 1010b, XCER = 1000b for XMCM Operation



8.3 Changing Element Selection

Using the multichannel selection feature, a static group of 32 elements can be enabled and remains enabled with no CPU intervention until this allocation is modified. An arbitrary number of, group of, or all of the elements within a frame can be accessed by updating the block allocation registers during the course of the frame in response to the end-of-subframe interrupts (see Section 8.4).

NOTE: Do not affect the currently selected subframe when changing the selection.

The currently selected subframe is readable through the RCBLK and XCBLK bits in MCR for receive and transmit, respectively. The associated channel enable register cannot be modified if it is selected by the appropriate (R/X)P[A/B]BLK register to point toward the current subframe. Similarly, the (R/X)PABLK and (R/X)PBBLK bits in MCR cannot be modified while pointing to or being changed to point to the currently selected subframe. If the total number of elements is 16 or less, the current partition is always pointed to. In this case, only a reset of the serial port can change the element enabling.

8.4 End-of-Subframe Interrupt

At the end of every subframe (16 elements or less) boundary during multichannel operation, the receive interrupt (RINT), if RINTM = 01b in SPCR, or transmit interrupt (XINT), if XINTM = 01b in SPCR, is generated to the CPU. This interrupt indicates that a new partition has been crossed. You can then check the current partition and change the selection of subframes in the A and/or B partitions if they do not point to the current subframe. These interrupts are two CPU-clock high pulses. If RINTM = XINTM = 01b when (R/X)MCM = 0 (non-multichannel operation), interrupts are not generated.

8.5 Enhanced Multichannel Selection Mode

In addition to the normal multichannel selection mode, the C6474 McBSP has the enhanced multichannel selection mode that allows up to 128 channels to be enabled at any given time. The enhanced multichannel selection mode is selected by setting the enhanced receive multichannel selection enable bit (RMCME) and the enhanced transmit multichannel selection enable bit (XMCME) in MCR to 1. This mode works in conjunction with six additional enhanced receive/transmit channel enable registers in the C6474 McBSP: RCERE1, RCERE2, RCERE3, XCERE1, XCERE2, and XCERE3. The RCER and XCER described in Section 11.8 are replaced by the RCERE0 and XCERE1, respectively, in the C6474 McBSP.

When the RMCME and XMCME bits are cleared to zero, the C6474 McBSP is in the normal multichannel selection mode. For a detailed description, see [Section 8.2](#). In normal multichannel selection mode, RCERE1-RCERE3 and XCERE1-XCERE3 in the C6474 device are not used; RCERE0 and XCERE0 in the C6474 device function as RCER and XCER, respectively.

When the RMCME and XMCME bits are set to 1, the C6474 McBSP has 128-channel selection capability. RCERE0-RCERE3 and XCERE0-XCERE3 are used to enable up to 128 channels. Since up to 128 channels can be selected at one time, the (R/X)P[A/B]BLK and (R/X)CBLK values in MCR have no effect in this mode. But, if necessary, the (R/X)CBLK value can be read to determine the subframe that is active. Perform the following to enable up to 128 channels:

- Enable the selected channels in XCERE0-XCERE3 and RCERE0-RCERE3.
- Set RMCME = XMCME = 1 in MCR.
- Set RMCM and XMCM in MCR as desired.

Following are descriptions of how each XMCM bit value affects operation in the enhanced multichannel selection mode (similar to its function in normal multichannel selection mode):

- XMCM = 00b: The serial port transmits data over the DX pin for the number of elements programmed in XFRLN1. Thus, DX is driven during transmit.
- XMCM = 01b: Only those elements that need to be transmitted are selected via XCERE0-XCERE3. Only these selected elements are written to DXR and ultimately transmitted. In other words, if XINTM = 00b, which implies that an XINT is generated for every DXR-to-XSR copy, the number of XINT generated is equal to the number of elements selected via XCERE0-XCERE3 (and *not* equal to XFRLN1).
- XMCM = 10b: All elements are enabled, which means all the elements in a data frame (XFRLN1) are written to DXR and DXR-to-XSR copies occur at their respective times. However, DX is driven only for those elements that are selected via XCERE0-XCERE3, and is placed in the high-impedance state otherwise. In this case, if XINTM = 00b, the number of interrupts generated due to every DXR-to-XSR copy would equal the number of elements in that frame (XFRLN1).
- XMCM = 11b: This mode is a combination of the XMCM = 01b and 10b cases. In this mode, symmetric transmit and receive operation is forced. Select the desired receive channels by setting RCERE0-RCERE3. The elements enabled in XCERE0-XCERE3 can be either a subset of or the same as those selected in RCERE0-RCERE3. In this mode all elements are disabled, so DR and DX are in the high-impedance state. For receiving, an RBR-to-DRR copy occurs only for those elements that are selected via RCERE0-RCERE3. If RINT were to be generated for every RBR-to-DRR copy, it would occur as many times as the number of elements selected in RCERE0-RCERE3 (and *not* the number of elements programmed in RFRLN1). For transmitting, DXR is loaded and a DXR-to-XSR copy occurs for all the elements that are enabled via RCERE0-RCERE3. However, DX is driven only for those elements that are selected via XCER. Therefore, if XINTM = 00b, transmit interrupts to the CPU would be generated the same number of times as the number of elements selected in RCERE0-RCERE3 (not XCERE0-XCERE3).

8.6 DX Enabler: DXENA

The DXENA bit in SPCR controls the high impedance enable on the DX pin. When DXENA = 1, the McBSP enables extra delay for the DX pin turn-on time. This feature is useful for McBSP multichannel operations, such as in a time-division multiplexed (TDM) system. The McBSP supports up to 128 channels in a multichannel operation. These channels can be driven by different devices in a TDM data communication line, such as the T1/E1 line. In any multichannel operation where multiple devices transmit over the same DX line, you need to ensure that no two devices transmit data simultaneously, which results in bus contention. Enough dead time should exist between the transmission of the first data bit of the current device and the transmission of the last data bit of the previous device. In other words, the last data bit of the previous device needs to be disabled to a high-impedance state before the next device begins transmitting data to the same data line, as shown in Figure 47.

Figure 47. DX Timing for Multichannel Operation

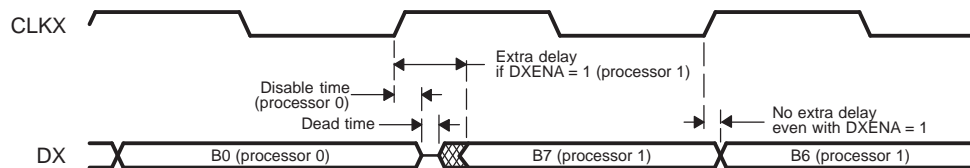

When two McBSPs are used to transmit data over the same TDM line, bus contention occurs if DXENA = 0. The first McBSP turns off the transmission of the last data bit (changes DX from valid to a high-impedance state) after a disable time specified in the device-specific data sheet. As shown in Figure 47, this disable time is measured from the CLKX active clock edge. The next McBSP turns on its DX pin (changes from a high-impedance state to valid) after a delay time. Again, this delay time is measured from the CLKX active clock edge. Bus contention occurs because the dead time between the two devices is not enough. You need to apply alternative software or hardware methods to ensure proper multichannel operation in this case.

If you set DXENA = 1 in the second McBSP, the second McBSP turns on its DX pin after some extra delay time. This ensures that the previous McBSP on the same DX line is disabled before the second McBSP starts driving out data. The DX enabler controls only the high-impedance enable on the DX pin, not the data itself. Data is shifted out to the DX pin at the same time as in the case when DXENA = 0. The only difference is that with DXENA = 1, the DX pin is masked to a high-impedance state for some extra CPU cycles before the data is seen on the TDM data line. Therefore, only the first bit of data is delayed. For the exact amount of delay, see the device-specific data sheet.

9 SPI Protocol: CLKSTP

A system conforming to the SPI protocol has a master-slave configuration. The SPI protocol is a 4-wire interface composed of serial data in (master in slave out or MISO), serial data out (master out slave in or MOSI), shift clock (SCK), and an active (low) slave enable (\overline{SS}) signal. Communication between the master and the slave is determined by the presence or absence of the master clock. Data transfer is initiated by the detection of the master clock and is terminated on absence of the master clock. The slave has to be enabled during this period of transfer. When the McBSP is the master, the slave enable is derived from the master transmit frame sync pulse (FSX). Example block diagrams of the McBSP as a master and as a slave are shown in [Figure 48](#) and [Figure 49](#), respectively.

Figure 48. SPI Configuration: McBSP as the Master

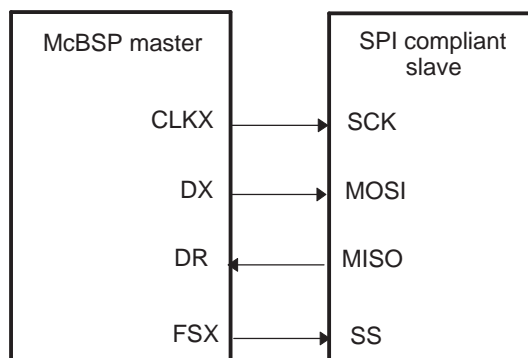
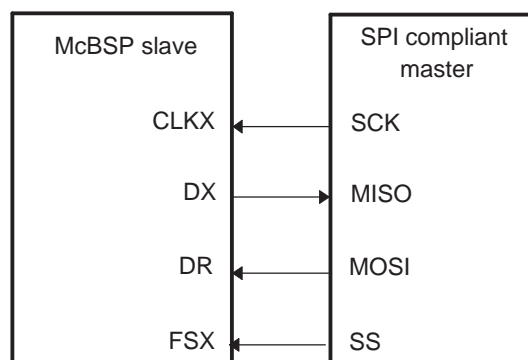

Figure 49. Configuration: McBSP as the Slave



The clock stop mode (CLKSTP) of the McBSP provides compatibility with the SPI protocol. The McBSP supports two SPI transfer formats that are specified by the clock stop mode bits (CLKSTP) in SPCR. The CLKSTP bits in conjunction with the CLKXP bit in PCR allows serial clocks to be stopped between transfers using one of four possible timing variations. [Figure 50](#) and [Figure 51](#) show the timing diagrams of the two SPI transfer formats and the four timing variations.

NOTE: The digital loopback mode (DLB = 1 in SPCR cannot be used in conjunction with the clock stop mode (CLKSTP = 1x).)

Figure 50. SPI Transfer with CLKSTP = 10b

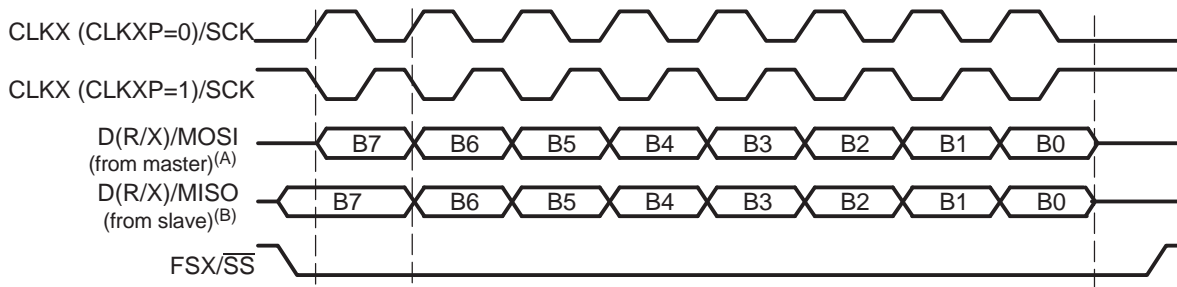

- A If the McBSP is the SPI master (CLKXM = 1), MOSI=DX. If the McBSP is the SPI slave (CLKXM = 0), MOSI = DR.
 B If the McBSP is the SPI master (CLKXM = 1), MISO=DR. If the McBSP is the SPI slave (CLKXM = 0), MISO = DX.

Figure 51. SPI Transfer with CLKSTP = 11b

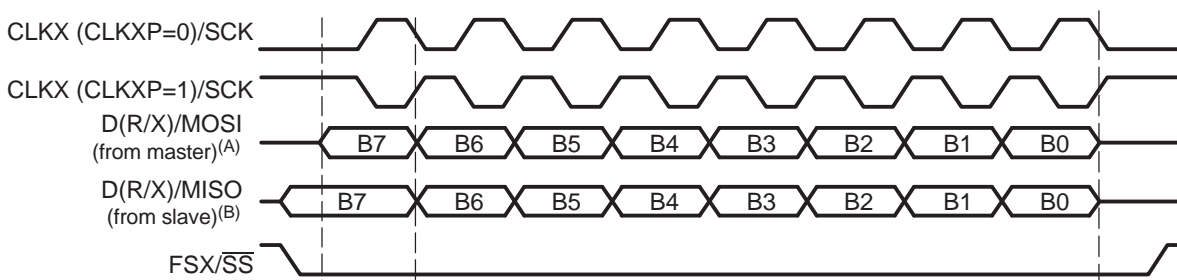

- A If the McBSP is the SPI master (CLKXM = 1), MOSI=DX. If the McBSP is the SPI slave (CLKXM = 0), MOSI = DR.
 B If the McBSP is the SPI master (CLKXM = 1), MISO=DR. If the McBSP is the SPI slave (CLKXM = 0), MISO = DX.

The CLKSTP bits in SPCR and the CLKXP bit in PCR select the appropriate clock scheme for a particular SPI interface. The CLKSTP and CLKXP bits determine the following conditions:

- Whether clock stop mode is enabled or not
- In clock stop mode, whether the clock is high or low when stopped
- In clock stop mode, whether the first clock edge occurs at the start of the first data bit or at the middle of the first data bit

The CLKXP bit selects the edge on which data is transmitted (driven) and received (sampled).

Figure 50 is the timing diagram when CLKSTP = 10b. In this SPI transfer format, the transition of the first clock edge (CLKX) marks the beginning of data transfer, provided the slave enable (FSX/SS) is already asserted. Data transfer is synchronized to the first clock edge.

Figure 51 is the timing diagram when CLKSTP = 11b. Data transfer begins before the transition of the serial clock. Therefore, the transition of the slave enable signal FSX/SS from high to low, instead of the transition of the serial clock, marks the beginning of transfer in this SPI transfer format. In SPI master mode, as well as SPI slave mode, the McBSP requires an FSX/SS edge for each transfer. This means the FSX/SS signal must toggle for each word. The McBSP clock stop mode requires single-phase frames ((R/X)PHASE = 0) and one element per frame ((R/X)FRLLEN = 0).

When the McBSP is configured to operate in SPI mode, both the transmitter and the receiver operate together as a master or a slave. The McBSP is a master when it generates clocks. When the McBSP is the SPI master, CLKX drives both its own internal receive clock (CLKR) and the serial clock (SCK) of the SPI slave. The FSR and CLKR signals should not be used in SPI mode. These do not function as SPI signals like the FSX and CLKX signals. In conjunction with CLKSTP enabled, CLKXM = 1 (in PCR) indicates that the McBSP is a master, and CLKXM = 0 indicates that the McBSP is an SPI slave. The slave enable signal (FSX/SS) enables the serial data input and output driver on the slave device (the device not providing the output clock).

9.1 **McBSP Operation as the SPI Master**

When the McBSP is the SPI master, it generates the master clock CLKX and the slave enable FSX. Therefore, CLKX should be configured as an output (CLKXM = 1) and FSX should be configured as an output that can be connected to the slave enable (\overline{SS}) input on the slave device (FSXM = 1). The DXR-to-XSR transfer of each element generates the slave enable FSX (FSGM = 0 in SRGR). Therefore to receive an element in SPI master mode, the McBSP must also simultaneously transmit an element (write to DXR) in order to generate the necessary slave enable FSX. The FSX needs to be asserted (low) to enable the slave before the McBSP starts shifting out data on the DX pin (see the MOSI and FSX waveforms in [Figure 50](#) and [Figure 51](#)). Therefore, the XDATDLY and RDATDLY bits must be programmed to 1. When the McBSP is the SPI master, an XDATDLY value of 0 or 2 causes undefined operation and an RDATDLY value of 0 causes the received data to be shifted incorrectly.

As the SPI master, the McBSP generates CLKX and FSX through the internal sample rate generator. As discussed in [Section 4.3.1](#), the CLKSM bit in SRGR should be set to specify either the CPU clock or the external clock input (CLKS) as the clock source to the internal sample rate generator. The CLKGDV (clock divide ratio) in SRGR should be programmed to generate CLKX at the required SPI data rate. The McBSP generates a continuous clock (CLKX) internally and gates the clock off (stops the clock) to the external interface when transfers are finished. The McBSP receive clock is provided from the internal continuously running clock, so the receiver and transmitter both work internally as if clocks do not stop. Selection of the clock stop modes overrides the frame generator bit fields (FPER and FWID) in SRGR.

9.2 **McBSP Operation as the SPI Slave**

When the McBSP is an SPI slave device, the master clock CLKX and slave enable FSX are generated by an external SPI master, as shown in [Figure 49](#). Thus, the CLKX and FSX pins are configured as inputs by clearing the CLKXM and FSXM bits in PCR to 0. In SPI mode, the FSX and CLKX inputs are also utilized as the internal FSR and CLKR signals for data reception. Data transfer is synchronized to the master clock CLKX and the internal serial port logic performs transfers using only the exact number of input clock pulses CLKX per data bit. The external master needs to assert FSX (low) before the transfer of data begins. FSX is used in its asynchronous form and it controls the McBSP initial drive of data to the DX pin.

When the McBSP is a slave, the (R/X)DATDLY bits in the receive/transmit control register ((R/X)CR) should be cleared to 0. XDATDLY = 0 ensures that the first data to be transmitted is available on the DX pin. The MISO waveform in [Figure 50](#) and [Figure 51](#) shows how the McBSP transmits data as an SPI slave. RDATDLY = 0 ensures that the McBSP is ready to receive data from the SPI master as soon as it detects the serial clock CLKX. Depending on the clock stop mode used, data is received at various clock edges.

Although the CLKX signal is generated externally by the master, the internal sample rate generator of the McBSP must be enabled for proper SPI slave mode operation. The internal sample rate clock is then used to synchronize the input clock (CLKX) and frame sync (FSX) from the master to the CPU clock. Accordingly, the CLKSM bit in SRGR should be left at the default value (CLKSM = 1) to specify the CPU clock as the clock source of the sample rate generator. Furthermore, the CLKGDV bits in SRGR must be set to a value such that the rate of the internal clock CLKG is at least eight times that of the SPI data rate. This rate is achieved by programming the sample rate generator to its maximum speed (CLKGDV = 1) for all SPI transfer rates.

9.3 McBSP Initialization for SPI Mode

The operation of the serial port during device reset, transmitter reset, and receiver reset is described in [Section 3.1](#). For McBSP operation as a master or a slave in SPI mode, you must follow these steps for proper initialization:

1. Set $XRST = RRST = 0$ in SPCR.
2. Program the necessary McBSP configuration registers (and not the data registers) as required when the serial port is in the reset state ($XRST = RRST = 0$). Write the desired value into the CLKSTP bits in SPCR.
3. Set the GRST bit to 1 in SPCR to get the sample rate generator out of reset.
4. Wait two bit clocks for the McBSP to reinitialize.
5. Depending upon whether the CPU or DMA services the McBSP, perform step (a) if the CPU is used, or step (b) if the DMA is used.
 - (a) If the CPU is used to service the McBSP, set $XRST = RRST = 1$ to enable the serial port. Note that the value written to SPCR at this time should have only the reset bits changed to 1 and the remaining bit-fields should have the same values as in steps 2 and 4 above.
 - (b) If the DMA is used to perform data transfers, the DMA should be initialized first with the appropriate read/write syncs and the start bit set to run. The DMA waits for the synchronization events to occur. Now, pull the McBSP out of reset by setting $XRST = RRST = 1$.
6. Wait two bit clocks for the receiver and transmitter to become active.

10 McBSP Pins as General-Purpose I/O

Two conditions allow the serial port pins (CLKX, FSX, DX, CLKR, FSR, DR, and CLKS) to be used as general-purpose I/O pins rather than serial port pins:

- The related portion (transmitter or receiver) of the serial port is in reset: (R/X)RST = 0 in SPCR
- General-purpose I/O is enabled for the related portion of the serial port: (R/X)IOEN = 1 in PCR

The PCR bits configure each of the McBSP pins as general-purpose inputs or outputs, as shown in [Table 15](#). In the case of FS(R/X), FS(R/X)M = 0 configures the pin as an input and FS(R/X)M = 1 configures the pin as an output. When configured as an output, the value driven on FS(R/X) is the value stored in FS(R/X)P. If configured as an input, the FS(R/X)P becomes a read-only bit that reflects the status of that signal. CLK(R/X)M and CLK(R/X)P work similarly for CLK(R/X). When the transmitter is selected as general-purpose I/O, the value of the DXSTAT bit in PCR is driven onto DX. DR is always an input and its value is held in the DRSTAT bit in PCR. To configure CLKS as a general-purpose input, both the transmitter and receiver have to be in the reset state and (R/X)IOEN has to be set to 1, because (R/X)IOEN is always an input to the McBSP and it affects both transmit and receive operations.

Table 15. Configuration of Pins as General Purpose I/O

| Pin | General-Purpose I/O Enabled When... | Output | | Input | |
|------|--------------------------------------|----------------------------|--------------------------|----------------------------|-------------------------|
| | | Selected as Output When... | Output Value Driven From | Selected as Input When ... | Input Value Readable on |
| CLKX | XRST = 0, XIOEN = 1 | CLKXM = 1 | CLKXP | CLKXM = 0 | CLKXP |
| FSX | XRST = 0, XIOEN = 1 | FSXM = 1 | FSXP | FSXM = 0 | FSXP |
| DX | XRST = 0, XIOEN = 1 | Always | DX_STAT | Never | N/A |
| CLKR | RRST = 0, RIOEN = 1 | CLKRM = 1 | CLKRP | CLKRM = 0 | CLKRP |
| FSR | RRST = 0, RIOEN = 1 | FSRM = 1 | FSRP | FSRM = 0 | FSRP |
| DR | RRST = 0, RIOEN = 1 | Never | N/A | Always | DR_STAT |
| CLKS | RRST = XRST = 0 RIOEN = XIOEN = 1 | Never | N/A | Always | CLKS_STAT |

11 McBSP Registers

[Table 16](#) lists the registers for the C6474 DSP. For the memory address of these registers, see the device-specific data sheet.

On the C6474 McBSP, the control registers are accessible via the internal configuration bus. You should halt the McBSP before making changes to the serial port control register (SPCR), receive control register (RCR), transmit control register (XCR), and pin control register (PCR). Changes made to these registers without halting the McBSP could result in an undefined state.

Table 16. McBSP Registers

| Acronym | Register Name | McBSPs on Device | | See |
|---------|--|------------------|---------|-------------------------------|
| | | McBSP 0 | McBSP 1 | |
| RBR | Receive buffer register | RBR0 | RBR1 | |
| RSR | Receive shift register | RSR0 | RSR1 | |
| XSR | Transmit shift register | XSR0 | XSR1 | |
| DRR | Data receive register | DRR0 | DRR1 | Section 11.1 |
| DXR | Data transmit register | DXR0 | DXR1 | Section 11.2 |
| SPCR | Serial port control register | SPCR0 | SPCR1 | Section 11.3 |
| RCR | Receive control register | RCR0 | RCR1 | Section 11.4 |
| XCR | Transmit control register | XCR0 | XCR1 | Section 11.5 |
| SRGR | Sample rate generator register | SRGR0 | SRGR1 | Section 11.6 |
| MCR | Multichannel control register | MCR0 | MCR1 | Section 11.7 |
| RCERE0 | Receive Channel Enable Register Partition A/B | RCERE00 | RCERE01 | Section 11.10 |
| XCERE0 | Transmit Channel Enable Register Partition A/B | XCERE00 | XCERE01 | Section 11.11 |
| RCERE1 | Receive Channel Enable Register Partition C/D | RCERE10 | RCERE11 | Section 11.10 |
| XCERE1 | Transmit Channel Enable Register Partition C/D | XCERE10 | XCERE11 | Section 11.11 |
| RCERE2 | Receive Channel Enable Register Partition E/F | RCERE20 | RCERE21 | Section 11.10 |
| XCERE2 | Transmit Channel Enable Register Partition E/F | XCERE20 | XCERE21 | Section 11.11 |
| RCERE3 | Receive Channel Enable Register Partition G/H | RCERE30 | RCERE31 | Section 11.10 |
| XCERE3 | Transmit Channel Enable Register Partition G/H | XCERE30 | XCERE31 | Section 11.11 |
| PCR | Pin control register | PCR0 | PCR1 | Section 11.12 |
| PID | Peripheral Identification Register | PID0 | PID1 | |

11.1 Data Receive Register (DRR)

The data receive register (DRR) contains the value to be written to the data bus. For devices with an EDMA controller, DRR is mapped to memory locations on both the EDMA bus (data port) and the peripheral bus (configuration bus). For the memory address of these registers, see the device-specific data sheet. DRR is accessible via the peripheral bus and via the EDMA bus. Both the CPU and the EDMA controller can access DRR in all the memory-mapped locations. An access to *any* EDMA bus location is equivalent to an access to DRR of the corresponding McBSP. For example, a read from any word-aligned address in a DRR location on the EDMA bus is equivalent to a read from the DRR of the corresponding McBSP on the peripheral bus. The EDMA controller should be set up to use the EDMA bus for serial port servicing, freeing up the peripheral bus for other functions.

The data receive register (DRR) is shown in [Figure 52](#) and described in [Table 17](#).

Figure 52. Data Receive Register (DRR)

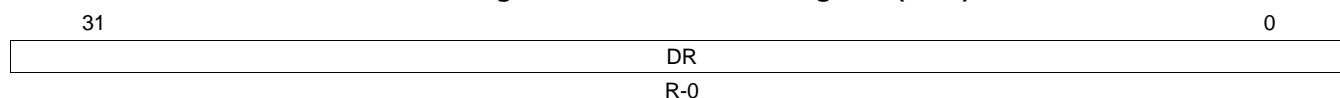

LEGEND: R = Read only; -n = value after reset

Table 17. Data Receive Register (DRR) Field Descriptions

| Bit | Field | Value | Description |
|------|-------|--------------|--|
| 31-0 | DR | 0-FFFF FFFFh | Data receive register value to be written to the data bus. |

11.2 Data Transmit Register (DXR)

The data transmit register (DXR) contains the value to be loaded into the data transmit shift register (XSR). For devices with an EDMA controller, DXR is mapped to memory locations on both the EDMA bus (data port) and the peripheral bus (configuration bus). For the memory address of these registers, see the device-specific data sheet. DXR is accessible via the peripheral bus and the EDMA bus. Both the CPU and the EDMA controller can access DXR in all the memory-mapped locations. An access to *any* EDMA bus location is equivalent to an access to DXR of the corresponding McBSP. For example, a write to any word-aligned address in a DXR location on the EDMA bus is equivalent to a write to the DXR of the corresponding McBSP on the peripheral bus. The EDMA controller should be set up to use the EDMA bus for serial port servicing, freeing up the peripheral bus for other functions.

The data transmit register (DXR) is shown in [Figure 53](#) and described in [Table 18](#).

Figure 53. Data Transmit Register (DXR)

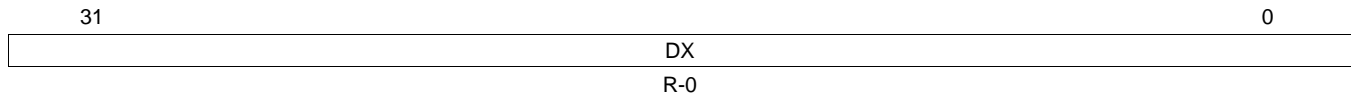

LEGEND: R = Read only; -n = value after reset

Table 18. Data Transmit Register (DXR) Field Descriptions

| Bit | Field | Value | Description |
|------|-------|--------------|--|
| 31-0 | DX | 0-FFFF FFFFh | Data transmit register value to be loaded into the data transmit shift register (XSR). |

11.3 Serial Port Control Register (SPCR)

The serial port is configured via the serial port control register (SPCR) and the pin control register (PCR). The SPCR contains McBSP status control bits.

The serial port control register (SPCR) is shown in [Figure 54](#) and described in [Table 19](#).

Figure 54. Serial Port Control Register (SPCR)

| | | | | | | | | | | | | | | | |
|----------|--|----------|--|--------|--|----------|--|--------|--|-------|--|-------|----|----|--|
| 31 | | | | | | | | | | 26 | | 25 | 24 | | |
| Reserved | | | | | | | | | | FREE | | SOFT | | | |
| R-0 | | | | | | | | | | R/W-0 | | R/W-0 | | | |
| 23 | | 22 | | 21 | | 20 | | 19 | | 18 | | 17 | | 16 | |
| FRST | | GRST | | XINTM | | XSYNCERR | | XEMPTY | | XRDY | | XRST | | | |
| R/W-0 | | R/W-0 | | R/W-0 | | R/W-0 | | R-0 | | R-0 | | R/W-0 | | | |
| 15 | | 14 | | 13 | | 12 | | 11 | | 10 | | 8 | | | |
| DLB | | RJUST | | CLKSTP | | Reserved | | | | | | | | | |
| R/W-0 | | R/W-0 | | R/W-0 | | R-0 | | | | | | | | | |
| 7 | | 6 | | 5 | | 4 | | 3 | | 2 | | 1 | | 0 | |
| DXENA | | Reserved | | RINTM | | RSYNCERR | | RFULL | | RRDY | | RRST | | | |
| R/W-0 | | R-0 | | R/W-0 | | R/W-0 | | R-0 | | R-0 | | R/W-0 | | | |

LEGEND: R = Read only; R/W = Read/ Write; -n = value after reset

Table 19. Serial Port Control Register (SPCR) Field Descriptions

| Bit | Field | Value | Description |
|-------|----------|-------|--|
| 31-26 | Reserved | 0 | Reserved. The reserved bit location is always read as 0. A value written to this field has no effect. |
| 25 | FREE | | Free-running enable mode bit. This bit is used in conjunction with SOFT bit to determine state of serial port clock during emulation halt. |
| | | 0 | Free-running mode is disabled. During emulation halt, SOFT bit determines operation of McBSP. |
| 24 | SOFT | 1 | Free-running mode is enabled. During emulation halt, serial clocks continue to run. |
| | | | Soft bit enable mode bit. This bit is used in conjunction with FREE bit to determine state of serial port clock during emulation halt. This bit has no effect if FREE = 1. |
| 23 | FRST | 0 | Soft mode is disabled. Serial port clock stops immediately during emulation halt, thus aborting any transmissions. |
| | | 1 | Soft mode is enabled. During emulation halt, serial port clock stops after completion of current transmission. |
| 22 | GRST | | Frame-sync generator reset bit. |
| | | 0 | Frame-synchronization logic is reset. Frame-sync signal (FSG) is not generated by the sample-rate generator. |
| 21-20 | XINTM | 1 | Frame-sync signal (FSG) is generated after (FPER + 1) number of CLKG clocks; that is, all frame counters are loaded with their programmed values. |
| | | | Sample-rate generator reset bit. |
| 19 | XSYNCERR | 0 | Sample-rate generator is reset. |
| | | 1 | Sample-rate generator is taken out of reset. CLKG is driven as per programmed value in sample-rate generator register (SRGR). |
| 19 | XINTM | 0-3h | Transmit interrupt (XINT) mode bit. |
| | | 0 | Reserved. |
| | | 1h | XINT is generated by end-of-block or end-of-frame in multichannel operation. |
| | | 2h | XINT is generated by a new frame synchronization. |
| 19 | XSYNCERR | 3h | XINT is generated by XSYNCERR. |
| | | | Transmit synchronization error bit. Writing a 1 to XSYNCERR sets the error condition when the transmitter is enabled (XRST = 1). Thus, it is used mainly for testing purposes or if this operation is desired. |
| | | 0 | No synchronization error is detected. |
| | | 1 | Synchronization error is detected. |

Table 19. Serial Port Control Register (SPCR) Field Descriptions (continued)

| Bit | Field | Value | Description |
|-------|----------|---|---|
| 18 | XEMPTY | 0 1 | Transmit shift register empty bit. XSR is empty. XSR is not empty. |
| 17 | XRDY | 0 1 | Transmitter ready bit. Transmitter is not ready. Transmitter is ready for new data in DXR. |
| 16 | XRST | 0 1 | Transmitter reset bit resets or enables the transmitter. Serial port transmitter is disabled and in reset state. Serial port transmitter is enabled. |
| 15 | DLB | 0 1 | Digital loop back mode enable bit. Digital loop back mode is disabled. Digital loop back mode is enabled. |
| 14-13 | RJUST | 0-3h 0 1h 2h 3h | Receive sign-extension and justification mode bit. Right-justify and zero-fill MSBs in DRR. Right-justify and sign-extend MSBs in DRR. Left-justify and zero-fill LSBs in DRR. Reserved |
| 12-11 | CLKSTP | 0-3h 0 1h 2h 3h 2h 3h | Clock stop mode bit. In SPI mode, operates in conjunction with CLKXP bit of pin control register (PCR). Clock stop mode is disabled. Normal clocking for non-SPI mode. Reserved In SPI mode with data sampled on rising edge (CLKXP = 0): Clock starts with rising edge without delay. Clock starts with falling edge with delay. In SPI mode with data sampled on falling edge (CLKXP = 1): Clock starts with falling edge without delay. Clock starts with falling edge with delay. |
| 10-8 | Reserved | 0 | Reserved. The reserved bit location is always read as 0. A value written to this field has no effect. |
| 7 | DXENA | 0 1 | DX enabler bit. DX enabler is off. DX enabler is on. |
| 6 | Reserved | 0 | Reserved. The reserved bit location is always read as 0. A value written to this field has no effect. |
| 5-4 | RINTM | 0-3h 0 1h 2h 3h | Receive interrupt (RINT) mode bit. Reserved. RINT is generated by end-of-block or end-of-frame in multichannel operation. RINT is generated by a new frame synchronization. RINT is generated by RSYNCERR. |
| 3 | RSYNCERR | 0 1 | Receive synchronization error bit. Writing a 1 to RSYNCERR sets the error condition when the receiver is enabled (RRST = 1). Thus, it is used mainly for testing purposes or if this operation is desired. No synchronization error is detected. Synchronization error is detected. |
| 2 | RFULL | 0 1 | Receive shift register full bit. RBR is not in overrun condition. DRR is not read, RBR is full, and RSR is also full with new word. |
| 1 | RRDY | 0 1 | Receiver ready bit. Receiver is not ready. Receiver is ready with data to be read from DRR. |

Table 19. Serial Port Control Register (SPCR) Field Descriptions (continued)

| Bit | Field | Value | Description |
|-----|-------|-------|--|
| 0 | RRST | 0 | The serial port receiver is disabled and in reset state. |
| | | 1 | The serial port receiver is enabled. |

11.4 Receive Control Register (RCR)

The receive control register (RCR) configures parameters of the receive operations.

The receive control register (RCR) is shown in [Figure 55](#) and described in [Table 20](#).

Figure 55. Receive Control Register (RCR)

| | | | | | | | | | |
|----------|--------|---------|----------|----------|-------|---------|----|----|----|
| 31 | 30 | 24 | 23 | 21 | 20 | 19 | 18 | 17 | 16 |
| RPHASE | RFRLN2 | RWDLEN2 | RWDLEN2 | RCOMPAND | RFIG | RDATDLY | | | |
| R/W-0 | R/W-0 | R/W-0 | R/W-0 | R/W-0 | R/W-0 | R/W-0 | | | |
| 15 | 14 | 8 | 7 | 5 | 4 | 3 | 0 | | |
| Reserved | RFRLN1 | RWDLEN1 | RWDREVRS | Reserved | | | | | |
| R-0 | R/W-0 | R/W-0 | R/W-0 | R-0 | | | | | |

LEGEND: R = Read only; R/ W = Read/Write; -n = value after reset

Table 20. Receive Control Register (RCR) Field Descriptions

| Bit | Field | Value | Description |
|-------|--------|---|---|
| 31 | RPHASE | 0 1 | Receive phases bit. Single-phase frame Dual-phase frame |
| 30-24 | RFRLN2 | 0-7Fh 0 1 2 3 4 5 6 7 8 9 10 11 12 13 14 15 16 17 18 19 20 21 22 23 24 25 26 27 28 29 | (RFRLN2 + 1) specifies the receive frame length (number of words) in phase 2. 1 word in phase 2 2 words in phase 2 3 words in phase 2 4 words in phase 2 5 words in phase 2 6 words in phase 2 7 words in phase 2 8 words in phase 2 9 words in phase 2 10 words in phase 2 11 words in phase 2 12 words in phase 2 13 words in phase 2 14 words in phase 2 15 words in phase 2 16 words in phase 2 17 words in phase 2 18 words in phase 2 19 words in phase 2 20 words in phase 2 21 words in phase 2 22 words in phase 2 23 words in phase 2 24 words in phase 2 25 words in phase 2 26 words in phase 2 27 words in phase 2 28 words in phase 2 29 words in phase 2 30 words in phase 2 |

Table 20. Receive Control Register (RCR) Field Descriptions (continued)

| Bit | Field | Value | Description |
|-----|-------|-------|---------------------|
| | | 30 | 31 words in phase 2 |
| | | 31 | 32 words in phase 2 |
| | | 32 | 33 words in phase 2 |
| | | 33 | 34 words in phase 2 |
| | | 34 | 35 words in phase 2 |
| | | 35 | 36 words in phase 2 |
| | | 36 | 37 words in phase 2 |
| | | 37 | 38 words in phase 2 |
| | | 38 | 39 words in phase 2 |
| | | 39 | 40 words in phase 2 |
| | | 40 | 41 words in phase 2 |
| | | 41 | 42 words in phase 2 |
| | | 42 | 43 words in phase 2 |
| | | 43 | 44 words in phase 2 |
| | | 44 | 45 words in phase 2 |
| | | 45 | 46 words in phase 2 |
| | | 46 | 47 words in phase 2 |
| | | 47 | 48 words in phase 2 |
| | | 48 | 49 words in phase 2 |
| | | 49 | 50 words in phase 2 |
| | | 50 | 51 words in phase 2 |
| | | 51 | 52 words in phase 2 |
| | | 52 | 53 words in phase 2 |
| | | 53 | 54 words in phase 2 |
| | | 54 | 55 words in phase 2 |
| | | 55 | 56 words in phase 2 |
| | | 56 | 57 words in phase 2 |
| | | 57 | 58 words in phase 2 |
| | | 58 | 59 words in phase 2 |
| | | 59 | 60 words in phase 2 |
| | | 60 | 61 words in phase 2 |
| | | 61 | 62 words in phase 2 |
| | | 62 | 63 words in phase 2 |
| | | 63 | 64 words in phase 2 |
| | | 64 | 65 words in phase 2 |
| | | 65 | 66 words in phase 2 |
| | | 66 | 67 words in phase 2 |
| | | 67 | 68 words in phase 2 |
| | | 68 | 69 words in phase 2 |
| | | 69 | 70 words in phase 2 |
| | | 70 | 71 words in phase 2 |
| | | 71 | 72 words in phase 2 |
| | | 72 | 73 words in phase 2 |
| | | 73 | 74 words in phase 2 |
| | | 74 | 75 words in phase 2 |
| | | 75 | 76 words in phase 2 |
| | | 76 | 77 words in phase 2 |

Table 20. Receive Control Register (RCR) Field Descriptions (continued)

| Bit | Field | Value | Description |
|-----|-------|-------|----------------------|
| | | 77 | 78 words in phase 2 |
| | | 78 | 79 words in phase 2 |
| | | 79 | 80 words in phase 2 |
| | | 80 | 81 words in phase 2 |
| | | 81 | 82 words in phase 2 |
| | | 82 | 83 words in phase 2 |
| | | 83 | 84 words in phase 2 |
| | | 84 | 85 words in phase 2 |
| | | 85 | 86 words in phase 2 |
| | | 86 | 87 words in phase 2 |
| | | 87 | 88 words in phase 2 |
| | | 88 | 89 words in phase 2 |
| | | 89 | 90 words in phase 2 |
| | | 90 | 91 words in phase 2 |
| | | 91 | 92 words in phase 2 |
| | | 92 | 93 words in phase 2 |
| | | 93 | 94 words in phase 2 |
| | | 94 | 95 words in phase 2 |
| | | 95 | 96 words in phase 2 |
| | | 96 | 97 words in phase 2 |
| | | 97 | 98 words in phase 2 |
| | | 98 | 99 words in phase 2 |
| | | 99 | 100 words in phase 2 |
| | | 100 | 101 words in phase 2 |
| | | 101 | 102 words in phase 2 |
| | | 102 | 103 words in phase 2 |
| | | 103 | 104 words in phase 2 |
| | | 104 | 105 words in phase 2 |
| | | 105 | 106 words in phase 2 |
| | | 106 | 107 words in phase 2 |
| | | 107 | 108 words in phase 2 |
| | | 108 | 109 words in phase 2 |
| | | 109 | 110 words in phase 2 |
| | | 110 | 111 words in phase 2 |
| | | 111 | 112 words in phase 2 |
| | | 112 | 113 words in phase 2 |
| | | 113 | 114 words in phase 2 |
| | | 114 | 115 words in phase 2 |
| | | 115 | 116 words in phase 2 |
| | | 116 | 117 words in phase 2 |
| | | 117 | 118 words in phase 2 |
| | | 118 | 119 words in phase 2 |
| | | 119 | 120 words in phase 2 |
| | | 120 | 121 words in phase 2 |
| | | 121 | 122 words in phase 2 |
| | | 122 | 123 words in phase 2 |
| | | 123 | 124 words in phase 2 |

Table 20. Receive Control Register (RCR) Field Descriptions (continued)

| Bit | Field | Value | Description |
|-------|----------|-------|--|
| | | 124 | 125 words in phase 2 |
| | | 125 | 126 words in phase 2 |
| | | 126 | 127 words in phase 2 |
| | | 127 | 128 words in phase 2 |
| 23-21 | RWDLEN2 | 0-7h | Specifies the receive word length (number of bits) in phase 2. |
| | | 0 | Receive word length is 8 bits. |
| | | 1h | Receive word length is 12 bits. |
| | | 2h | Receive word length is 16 bits. |
| | | 3h | Receive word length is 20 bits. |
| | | 4h | Receive word length is 24 bits. |
| | | 5h | Receive word length is 32 bits. |
| | | 6h-7h | Reserved |
| 20-19 | RCOMPAND | 0-3h | Receive companding mode bit. Modes other than 00 are only enabled when RWDLEN1/2 bit is 000 (indicating 8-bit data). |
| | | 0 | No companding. |
| | | 1h | No companding, 8-bit data transfer starts with LSB first. |
| | | 2h | Compand using μ -law for receive data. |
| | | 3h | Compand using A-law for receive data. |
| 18 | RFIG | | Receive frame ignore bit. |
| | | 0 | Receive frame-synchronization pulses after the first pulse restarts the transfer. |
| | | 1 | Receive frame-synchronization pulses after the first pulse are ignored. |
| 17-16 | RDATDLY | 0-3h | Receive data delay bit. |
| | | 0 | 0-bit data delay |
| | | 1h | 1-bit data delay |
| | | 2h | 2-bit data delay |
| | | 3h | Reserved |
| 15 | Reserved | 0 | Reserved. The reserved bit location is always read as 0. A value written to this field has no effect. |
| 14-8 | RFRLLEN1 | 0-7Fh | (RFRLLEN1 + 1) specifies the receive frame length (number of words) in phase 1. |
| | | 0 | 1 word in phase 1 |
| | | 1 | 2 words in phase 1 |
| | | 2 | 3 words in phase 1 |
| | | 3 | 4 words in phase 1 |
| | | 4 | 5 words in phase 1 |
| | | 5 | 6 words in phase 1 |
| | | 6 | 7 words in phase 1 |
| | | 7 | 8 words in phase 1 |
| | | 8 | 9 words in phase 1 |
| | | 9 | 10 words in phase 1 |
| | | 10 | 11 words in phase 1 |
| | | 11 | 12 words in phase 1 |
| | | 12 | 13 words in phase 1 |
| | | 13 | 14 words in phase 1 |
| | | 14 | 15 words in phase 1 |
| | | 15 | 16 words in phase 1 |
| | | 16 | 17 words in phase 1 |
| | | 17 | 18 words in phase 1 |
| | | 18 | 19 words in phase 1 |
| | | 19 | 20 words in phase 1 |

Table 20. Receive Control Register (RCR) Field Descriptions (continued)

| Bit | Field | Value | Description |
|-----|-------|-------|---------------------|
| | | 20 | 21 words in phase 1 |
| | | 21 | 22 words in phase 1 |
| | | 22 | 23 words in phase 1 |
| | | 23 | 24 words in phase 1 |
| | | 24 | 25 words in phase 1 |
| | | 25 | 26 words in phase 1 |
| | | 26 | 27 words in phase 1 |
| | | 27 | 28 words in phase 1 |
| | | 28 | 29 words in phase 1 |
| | | 29 | 30 words in phase 1 |
| | | 30 | 31 words in phase 1 |
| | | 31 | 32 words in phase 1 |
| | | 32 | 33 words in phase 1 |
| | | 33 | 34 words in phase 1 |
| | | 34 | 35 words in phase 1 |
| | | 35 | 36 words in phase 1 |
| | | 36 | 37 words in phase 1 |
| | | 37 | 38 words in phase 1 |
| | | 38 | 39 words in phase 1 |
| | | 39 | 40 words in phase 1 |
| | | 40 | 41 words in phase 1 |
| | | 41 | 42 words in phase 1 |
| | | 42 | 43 words in phase 1 |
| | | 43 | 44 words in phase 1 |
| | | 44 | 45 words in phase 1 |
| | | 45 | 46 words in phase 1 |
| | | 46 | 47 words in phase 1 |
| | | 47 | 48 words in phase 1 |
| | | 48 | 49 words in phase 1 |
| | | 49 | 50 words in phase 1 |
| | | 50 | 51 words in phase 1 |
| | | 51 | 52 words in phase 1 |
| | | 52 | 53 words in phase 1 |
| | | 53 | 54 words in phase 1 |
| | | 54 | 55 words in phase 1 |
| | | 55 | 56 words in phase 1 |
| | | 56 | 57 words in phase 1 |
| | | 57 | 58 words in phase 1 |
| | | 58 | 59 words in phase 1 |
| | | 59 | 60 words in phase 1 |
| | | 60 | 61 words in phase 1 |
| | | 61 | 62 words in phase 1 |
| | | 62 | 63 words in phase 1 |
| | | 63 | 64 words in phase 1 |
| | | 64 | 65 words in phase 1 |
| | | 65 | 66 words in phase 1 |
| | | 66 | 67 words in phase 1 |

Table 20. Receive Control Register (RCR) Field Descriptions (continued)

| Bit | Field | Value | Description |
|-----|-------|-------|----------------------|
| | | 67 | 68 words in phase 1 |
| | | 68 | 69 words in phase 1 |
| | | 69 | 70 words in phase 1 |
| | | 70 | 71 words in phase 1 |
| | | 71 | 72 words in phase 1 |
| | | 72 | 73 words in phase 1 |
| | | 73 | 74 words in phase 1 |
| | | 74 | 75 words in phase 1 |
| | | 75 | 76 words in phase 1 |
| | | 76 | 77 words in phase 1 |
| | | 77 | 78 words in phase 1 |
| | | 78 | 79 words in phase 1 |
| | | 79 | 80 words in phase 1 |
| | | 80 | 81 words in phase 1 |
| | | 81 | 82 words in phase 1 |
| | | 82 | 83 words in phase 1 |
| | | 83 | 84 words in phase 1 |
| | | 84 | 85 words in phase 1 |
| | | 85 | 86 words in phase 1 |
| | | 86 | 87 words in phase 1 |
| | | 87 | 88 words in phase 1 |
| | | 88 | 89 words in phase 1 |
| | | 89 | 90 words in phase 1 |
| | | 90 | 91 words in phase 1 |
| | | 91 | 92 words in phase 1 |
| | | 92 | 93 words in phase 1 |
| | | 93 | 94 words in phase 1 |
| | | 94 | 95 words in phase 1 |
| | | 95 | 96 words in phase 1 |
| | | 96 | 97 words in phase 1 |
| | | 97 | 98 words in phase 1 |
| | | 98 | 99 words in phase 1 |
| | | 99 | 100 words in phase 1 |
| | | 100 | 101 words in phase 1 |
| | | 101 | 102 words in phase 1 |
| | | 102 | 103 words in phase 1 |
| | | 103 | 104 words in phase 1 |
| | | 104 | 105 words in phase 1 |
| | | 105 | 106 words in phase 1 |
| | | 106 | 107 words in phase 1 |
| | | 107 | 108 words in phase 1 |
| | | 108 | 109 words in phase 1 |
| | | 109 | 110 words in phase 1 |
| | | 110 | 111 words in phase 1 |
| | | 111 | 112 words in phase 1 |
| | | 112 | 113 words in phase 1 |
| | | 113 | 114 words in phase 1 |

Table 20. Receive Control Register (RCR) Field Descriptions (continued)

| Bit | Field | Value | Description |
|-----|----------|-------|---|
| | | 114 | 115 words in phase 1 |
| | | 115 | 116 words in phase 1 |
| | | 116 | 117 words in phase 1 |
| | | 117 | 118 words in phase 1 |
| | | 118 | 119 words in phase 1 |
| | | 119 | 120 words in phase 1 |
| | | 120 | 121 words in phase 1 |
| | | 121 | 122 words in phase 1 |
| | | 122 | 123 words in phase 1 |
| | | 123 | 124 words in phase 1 |
| | | 124 | 125 words in phase 1 |
| | | 125 | 126 words in phase 1 |
| | | 126 | 127 words in phase 1 |
| | | 127 | 128 words in phase 1 |
| 7-5 | RWDLEN1 | 0-7h | Specifies the receive word length (number of bits) in phase 1. |
| | | 0 | Receive word length is 8 bits. |
| | | 1h | Receive word length is 12 bits. |
| | | 2h | Receive word length is 16 bits. |
| | | 3h | Receive word length is 20 bits. |
| | | 4h | Receive word length is 24 bits. |
| | | 5h | Receive word length is 32 bits. |
| | | 6h-7h | Reserved |
| 4 | RWDREVRS | | Receive 32-bit reversal enable bit. |
| | | 0 | 32-bit reversal is disabled. |
| | | 1 | 32-bit reversal is enabled. 32-bit data is received LSB first. RWDLEN1/2 bit should be set to 5h (32-bit operation); otherwise, operation is undefined. |
| 3-0 | Reserved | 0 | Reserved. The reserved bit location is always read as 0. A value written to this field has no effect. |

11.5 Transmit Control Register (XCR)

The transmit control register (XCR) configures parameters of the transmit operations.

The transmit control register (XCR) is shown in [Figure 56](#) and described in [Table 21](#).

Figure 56. Transmit Control Register (XCR)

| | | | | | | | | | |
|----------|--------|---------|----------|----------|---------|----|----|----|----|
| 31 | 30 | 24 | 23 | 21 | 20 | 19 | 18 | 17 | 16 |
| XPHASE | XFRLN2 | XWDLEN2 | XCOMPAND | XFIG | XDATDLY | | | | |
| R/W-0 | R/W-0 | R/W-0 | R/W-0 | R/W-0 | R/W-0 | | | | |
| 15 | 14 | 8 | 7 | 5 | 4 | 3 | 0 | | |
| Reserved | XFRLN1 | XWDLEN1 | XWDREVRS | Reserved | | | | | |
| R-0 | R/W-0 | R/W-0 | R/W-0 | R-0 | | | | | |

LEGEND: R = Read only; R/ W = Read/Write; -n = value after reset

Table 21. Transmit Control Register (XCR) Field Descriptions

| Bit | Field | Value | Description |
|-------|--------|---|--|
| 31 | XPHASE | 0 1 | Transmit phases bit. Single-phase frame Dual-phase frame |
| 30-24 | XFRLN2 | 0-7Fh 0 1 2 3 4 5 6 7 8 9 10 11 12 13 14 15 16 17 18 19 20 21 22 23 24 25 26 27 28 29 | (XFRLN2 + 1) specifies the transmit frame length (number of words) in phase 2. 1 word in phase 2 2 words in phase 2 3 words in phase 2 4 words in phase 2 5 words in phase 2 6 words in phase 2 7 words in phase 2 8 words in phase 2 9 words in phase 2 10 words in phase 2 11 words in phase 2 12 words in phase 2 13 words in phase 2 14 words in phase 2 15 words in phase 2 16 words in phase 2 17 words in phase 2 18 words in phase 2 19 words in phase 2 20 words in phase 2 21 words in phase 2 22 words in phase 2 23 words in phase 2 24 words in phase 2 25 words in phase 2 26 words in phase 2 27 words in phase 2 28 words in phase 2 29 words in phase 2 30 words in phase 2 |

Table 21. Transmit Control Register (XCR) Field Descriptions (continued)

| Bit | Field | Value | Description |
|-----|-------|-------|---------------------|
| | | 30 | 31 words in phase 2 |
| | | 31 | 32 words in phase 2 |
| | | 32 | 33 words in phase 2 |
| | | 33 | 34 words in phase 2 |
| | | 34 | 35 words in phase 2 |
| | | 35 | 36 words in phase 2 |
| | | 36 | 37 words in phase 2 |
| | | 37 | 38 words in phase 2 |
| | | 38 | 39 words in phase 2 |
| | | 39 | 40 words in phase 2 |
| | | 40 | 41 words in phase 2 |
| | | 41 | 42 words in phase 2 |
| | | 42 | 43 words in phase 2 |
| | | 43 | 44 words in phase 2 |
| | | 44 | 45 words in phase 2 |
| | | 45 | 46 words in phase 2 |
| | | 46 | 47 words in phase 2 |
| | | 47 | 48 words in phase 2 |
| | | 48 | 49 words in phase 2 |
| | | 49 | 50 words in phase 2 |
| | | 50 | 51 words in phase 2 |
| | | 51 | 52 words in phase 2 |
| | | 52 | 53 words in phase 2 |
| | | 53 | 54 words in phase 2 |
| | | 54 | 55 words in phase 2 |
| | | 55 | 56 words in phase 2 |
| | | 56 | 57 words in phase 2 |
| | | 57 | 58 words in phase 2 |
| | | 58 | 59 words in phase 2 |
| | | 59 | 60 words in phase 2 |
| | | 60 | 61 words in phase 2 |
| | | 61 | 62 words in phase 2 |
| | | 62 | 63 words in phase 2 |
| | | 63 | 64 words in phase 2 |
| | | 64 | 65 words in phase 2 |
| | | 65 | 66 words in phase 2 |
| | | 66 | 67 words in phase 2 |
| | | 67 | 68 words in phase 2 |
| | | 68 | 69 words in phase 2 |
| | | 69 | 70 words in phase 2 |
| | | 70 | 71 words in phase 2 |
| | | 71 | 72 words in phase 2 |
| | | 72 | 73 words in phase 2 |
| | | 73 | 74 words in phase 2 |
| | | 74 | 75 words in phase 2 |
| | | 75 | 76 words in phase 2 |
| | | 76 | 77 words in phase 2 |

Table 21. Transmit Control Register (XCR) Field Descriptions (continued)

| Bit | Field | Value | Description |
|-----|-------|-------|----------------------|
| | | 77 | 78 words in phase 2 |
| | | 78 | 79 words in phase 2 |
| | | 79 | 80 words in phase 2 |
| | | 80 | 81 words in phase 2 |
| | | 81 | 82 words in phase 2 |
| | | 82 | 83 words in phase 2 |
| | | 83 | 84 words in phase 2 |
| | | 84 | 85 words in phase 2 |
| | | 85 | 86 words in phase 2 |
| | | 86 | 87 words in phase 2 |
| | | 87 | 88 words in phase 2 |
| | | 88 | 89 words in phase 2 |
| | | 89 | 90 words in phase 2 |
| | | 90 | 91 words in phase 2 |
| | | 91 | 92 words in phase 2 |
| | | 92 | 93 words in phase 2 |
| | | 93 | 94 words in phase 2 |
| | | 94 | 95 words in phase 2 |
| | | 95 | 96 words in phase 2 |
| | | 96 | 97 words in phase 2 |
| | | 97 | 98 words in phase 2 |
| | | 98 | 99 words in phase 2 |
| | | 99 | 100 words in phase 2 |
| | | 100 | 101 words in phase 2 |
| | | 101 | 102 words in phase 2 |
| | | 102 | 103 words in phase 2 |
| | | 103 | 104 words in phase 2 |
| | | 104 | 105 words in phase 2 |
| | | 105 | 106 words in phase 2 |
| | | 106 | 107 words in phase 2 |
| | | 107 | 108 words in phase 2 |
| | | 108 | 109 words in phase 2 |
| | | 109 | 110 words in phase 2 |
| | | 110 | 111 words in phase 2 |
| | | 111 | 112 words in phase 2 |
| | | 112 | 113 words in phase 2 |
| | | 113 | 114 words in phase 2 |
| | | 114 | 115 words in phase 2 |
| | | 115 | 116 words in phase 2 |
| | | 116 | 117 words in phase 2 |
| | | 117 | 118 words in phase 2 |
| | | 118 | 119 words in phase 2 |
| | | 119 | 120 words in phase 2 |
| | | 120 | 121 words in phase 2 |
| | | 121 | 122 words in phase 2 |
| | | 122 | 123 words in phase 2 |
| | | 123 | 124 words in phase 2 |

Table 21. Transmit Control Register (XCR) Field Descriptions (continued)

| Bit | Field | Value | Description |
|-------|----------|-------|---|
| | | 124 | 125 words in phase 2 |
| | | 125 | 126 words in phase 2 |
| | | 126 | 127 words in phase 2 |
| | | 127 | 128 words in phase 2 |
| 23-21 | XWDLEN2 | 0-7Fh | Specifies the transmit word length (number of bits) in phase 2. |
| | | 0 | Transmit word length is 8 bits. |
| | | 1h | Transmit word length is 12 bits. |
| | | 2h | Transmit word length is 16 bits. |
| | | 3h | Transmit word length is 20 bits. |
| | | 4h | Transmit word length is 24 bits. |
| | | 5h | Transmit word length is 32 bits. |
| | | 6h-7h | Reserved |
| 20-19 | XCOMPAND | 0-3h | Transmit companding mode bit. Modes other than 00 are only enabled when XWDLEN1/2 bit is 000 (indicating 8-bit data). |
| | | 0 | No companding. |
| | | 1h | No companding, 8-bit data transfer starts with LSB first. |
| | | 2h | Compand using μ -law for transmit data. |
| | | 3h | Compand using A-law for transmit data. |
| 18 | XFIG | | Transmit frame ignore bit. |
| | | 0 | Transmit frame-synchronization pulses after the first pulse restarts the transfer. |
| | | 1 | Transmit frame-synchronization pulses after the first pulse are ignored. |
| 17-16 | XDATDLY | 0-3h | Transmit data delay bit. |
| | | 0 | 0-bit data delay |
| | | 1h | 1-bit data delay |
| | | 2h | 2-bit data delay |
| | | 3h | Reserved |
| 15 | Reserved | 0 | Reserved. The reserved bit location is always read as 0. A value written to this field has no effect. |
| 14-8 | XFRLEN1 | 0-7Fh | (XFRLEN1 + 1) specifies the transmit frame length (number of words) in phase 1. |
| | | 0 | 1 word in phase 1 |
| | | 1 | 2 words in phase 1 |
| | | 2 | 3 words in phase 1 |
| | | 3 | 4 words in phase 1 |
| | | 4 | 5 words in phase 1 |
| | | 5 | 6 words in phase 1 |
| | | 6 | 7 words in phase 1 |
| | | 7 | 8 words in phase 1 |
| | | 8 | 9 words in phase 1 |
| | | 9 | 10 words in phase 1 |
| | | 10 | 11 words in phase 1 |
| | | 11 | 12 words in phase 1 |
| | | 12 | 13 words in phase 1 |
| | | 13 | 14 words in phase 1 |
| | | 14 | 15 words in phase 1 |
| | | 15 | 16 words in phase 1 |
| | | 16 | 17 words in phase 1 |
| | | 17 | 18 words in phase 1 |
| | | 18 | 19 words in phase 1 |
| | | 19 | 20 words in phase 1 |

Table 21. Transmit Control Register (XCR) Field Descriptions (continued)

| Bit | Field | Value | Description |
|-----|-------|-------|---------------------|
| | | 20 | 21 words in phase 1 |
| | | 21 | 22 words in phase 1 |
| | | 22 | 23 words in phase 1 |
| | | 23 | 24 words in phase 1 |
| | | 24 | 25 words in phase 1 |
| | | 25 | 26 words in phase 1 |
| | | 26 | 27 words in phase 1 |
| | | 27 | 28 words in phase 1 |
| | | 28 | 29 words in phase 1 |
| | | 29 | 30 words in phase 1 |
| | | 30 | 31 words in phase 1 |
| | | 31 | 32 words in phase 1 |
| | | 32 | 33 words in phase 1 |
| | | 33 | 34 words in phase 1 |
| | | 34 | 35 words in phase 1 |
| | | 35 | 36 words in phase 1 |
| | | 36 | 37 words in phase 1 |
| | | 37 | 38 words in phase 1 |
| | | 38 | 39 words in phase 1 |
| | | 39 | 40 words in phase 1 |
| | | 40 | 41 words in phase 1 |
| | | 41 | 42 words in phase 1 |
| | | 42 | 43 words in phase 1 |
| | | 43 | 44 words in phase 1 |
| | | 44 | 45 words in phase 1 |
| | | 45 | 46 words in phase 1 |
| | | 46 | 47 words in phase 1 |
| | | 47 | 48 words in phase 1 |
| | | 48 | 49 words in phase 1 |
| | | 49 | 50 words in phase 1 |
| | | 50 | 51 words in phase 1 |
| | | 51 | 52 words in phase 1 |
| | | 52 | 53 words in phase 1 |
| | | 53 | 54 words in phase 1 |
| | | 54 | 55 words in phase 1 |
| | | 55 | 56 words in phase 1 |
| | | 56 | 57 words in phase 1 |
| | | 57 | 58 words in phase 1 |
| | | 58 | 59 words in phase 1 |
| | | 59 | 60 words in phase 1 |
| | | 60 | 61 words in phase 1 |
| | | 61 | 62 words in phase 1 |
| | | 62 | 63 words in phase 1 |
| | | 63 | 64 words in phase 1 |
| | | 64 | 65 words in phase 1 |
| | | 65 | 66 words in phase 1 |
| | | 66 | 67 words in phase 1 |

Table 21. Transmit Control Register (XCR) Field Descriptions (continued)

| Bit | Field | Value | Description |
|-----|-------|-------|----------------------|
| | | 67 | 68 words in phase 1 |
| | | 68 | 69 words in phase 1 |
| | | 69 | 70 words in phase 1 |
| | | 70 | 71 words in phase 1 |
| | | 71 | 72 words in phase 1 |
| | | 72 | 73 words in phase 1 |
| | | 73 | 74 words in phase 1 |
| | | 74 | 75 words in phase 1 |
| | | 75 | 76 words in phase 1 |
| | | 76 | 77 words in phase 1 |
| | | 77 | 78 words in phase 1 |
| | | 78 | 79 words in phase 1 |
| | | 79 | 80 words in phase 1 |
| | | 80 | 81 words in phase 1 |
| | | 81 | 82 words in phase 1 |
| | | 82 | 83 words in phase 1 |
| | | 83 | 84 words in phase 1 |
| | | 84 | 85 words in phase 1 |
| | | 85 | 86 words in phase 1 |
| | | 86 | 87 words in phase 1 |
| | | 87 | 88 words in phase 1 |
| | | 88 | 89 words in phase 1 |
| | | 89 | 90 words in phase 1 |
| | | 90 | 91 words in phase 1 |
| | | 91 | 92 words in phase 1 |
| | | 92 | 93 words in phase 1 |
| | | 93 | 94 words in phase 1 |
| | | 94 | 95 words in phase 1 |
| | | 95 | 96 words in phase 1 |
| | | 96 | 97 words in phase 1 |
| | | 97 | 98 words in phase 1 |
| | | 98 | 99 words in phase 1 |
| | | 99 | 100 words in phase 1 |
| | | 100 | 101 words in phase 1 |
| | | 101 | 102 words in phase 1 |
| | | 102 | 103 words in phase 1 |
| | | 103 | 104 words in phase 1 |
| | | 104 | 105 words in phase 1 |
| | | 105 | 106 words in phase 1 |
| | | 106 | 107 words in phase 1 |
| | | 107 | 108 words in phase 1 |
| | | 108 | 109 words in phase 1 |
| | | 109 | 110 words in phase 1 |
| | | 110 | 111 words in phase 1 |
| | | 111 | 112 words in phase 1 |
| | | 112 | 113 words in phase 1 |
| | | 113 | 114 words in phase 1 |

Table 21. Transmit Control Register (XCR) Field Descriptions (continued)

| Bit | Field | Value | Description |
|-----|----------|-------|--|
| | | 114 | 115 words in phase 1 |
| | | 115 | 116 words in phase 1 |
| | | 116 | 117 words in phase 1 |
| | | 117 | 118 words in phase 1 |
| | | 118 | 119 words in phase 1 |
| | | 119 | 120 words in phase 1 |
| | | 120 | 121 words in phase 1 |
| | | 121 | 122 words in phase 1 |
| | | 122 | 123 words in phase 1 |
| | | 123 | 124 words in phase 1 |
| | | 124 | 125 words in phase 1 |
| | | 125 | 126 words in phase 1 |
| | | 126 | 127 words in phase 1 |
| | | 127 | 128 words in phase 1 |
| 7-5 | XWDLEN1 | 0-7h | Specifies the transmit word length (number of bits) in phase 1. |
| | | 0 | Transmit word length is 8 bits. |
| | | 1h | Transmit word length is 12 bits. |
| | | 2h | Transmit word length is 16 bits. |
| | | 3h | Transmit word length is 20 bits. |
| | | 4h | Transmit word length is 24 bits. |
| | | 5h | Transmit word length is 32 bits. |
| | | 6h-7h | Reserved |
| 4 | XWDREVRS | | Transmit 32-bit bit reversal feature enable bit. |
| | | 0 | 32-bit bit reversal is disabled. |
| | | 1 | 32-bit bit reversal is enabled. 32-bit data is transmitted LSB first. XWDLEN1/2 bit should be set to 5h (32-bit operation); otherwise, operation is undefined. |
| 3-0 | Reserved | 0 | Reserved. The reserved bit location is always read as 0. A value written to this field has no effect. |

11.6 Sample Rate Generator Register (SRGR)

The sample rate generator register (SRGR) controls the operation of various features of the sample rate generator.

The sample rate generator register (SRGR) is shown in [Figure 57](#) and described in [Table 22](#).

Figure 57. Sample Rate Generator Register (SRGR)

| | | | | | |
|-------|--------|-------|-------|--------|-------|
| 31 | 30 | 29 | 28 | 27 | 16 |
| GSYNC | CLKSTP | CLKSM | FSGM | FPER | |
| R/W-0 | R/W-0 | R/W-1 | R/W-0 | R/W-0 | |
| | | | | 8 | 7 |
| 15 | FWID | | | CLKGDV | |
| | | | | R/W-0 | R/W-1 |

LEGEND: R/W = Read/Write; -n = value after reset

Table 22. Sample Rate Generator Register (SRGR) Field Descriptions

| Bit | Field | Value | Description |
|-------|--------|--------|---|
| 31 | GSYNC | 0 1 | Sample-rate generator clock synchronization bit is only used when the external clock (CLKS) drives the sample-rate generator clock (CLKSM = 0). The sample-rate generator clock (CLKG) is free running. The sample-rate generator clock (CLKG) is running; however, CLKG is resynchronized and frame-sync signal (FSG) is generated only after detecting the receive frame-synchronization signal (FSR). Also, frame period (FPER) is a don't care because the period is dictated by the external frame-sync pulse. |
| 30 | CLKSP | 0 1 | CLKS polarity clock edge select bit is only used when the external clock (CLKS) drives the sample-rate generator clock (CLKSM = 0). Rising edge of CLKS generates CLKG and FSG. Falling edge of CLKS generates CLKG and FSG. |
| 29 | CLKSM | 0 1 | McBSP sample-rate generator clock mode bit. Sample-rate generator clock is derived from the CLKS pin. Sample-rate generator clock is derived from CPU clock. |
| 28 | FSGM | 0 1 | Sample-rate generator transmit frame-synchronization mode bit is only used when FSXM = 1 in PCR. Transmit frame-sync signal (FSX) is generated on every DXR-to-XSR copy. When FSGM = 0, FWID bit and FPER bit are ignored. Transmit frame-sync signal (FSX) is driven by the sample-rate generator frame-sync signal (FSG). |
| 27-16 | FPER | 0-FFFh | Frame period value plus 1 specifies when the next frame-sync signal becomes active. Range is 1 to 4096 sample-rate generator clock (CLKG) periods. |
| 15-8 | FWID | 0-FFFh | Frame width value plus 1 specifies the width of the frame-sync pulse (FSG) during its active period. |
| 7-0 | CLKGDV | 0-FFFh | Sample-rate generator clock (CLKG) divider value is used as the divide-down number to generate the required sample-rate generator clock frequency. |

11.7 Multichannel Control Register (MCR)

The multichannel control register (MCR) contains fields that control the multichannel selection mode. The enhanced 128-channel selection mode (selected by the RMCME and XMCME bits), which allows the McBSP to select 128 channels at any time.

The multichannel control register (MCR) is shown in [Figure 58](#) and described in [Table 23](#).

Figure 58. Multichannel Control Register (MCR)

| | | | | | | | | | | |
|----------|----|-------|--------|--------|-------|----------|----|-------|----|----|
| 31 | 26 | 25 | 24 | 23 | 22 | 21 | 20 | 18 | 17 | 16 |
| Reserved | | XMCME | XPBBLK | XPABLK | XCBLK | XMCM | | | | |
| R-0 | | R/W-0 | R/W-0 | R/W-0 | R-0 | R/W-0 | | | | |
| 15 | 10 | 9 | 8 | 7 | 6 | 5 | 4 | 2 | 1 | 0 |
| Reserved | | RMCME | RPBBLK | RPABLK | RCBLK | Reserved | | RMCM | | |
| R-0 | | R/W-0 | R/W-0 | R/W-0 | R-0 | R-0 | | R/W-0 | | |

LEGEND: R = Read, W = Write, n = value at reset

Table 23. Multichannel Control Register (MCR) Field Descriptions

| Bit | Field | Value | Description |
|-------|----------|---|---|
| 31-26 | Reserved | 0 | Reserved. The reserved bit location is always read as 0. A value written to this field has no effect. |
| 25 | XMCME | 0 1 | Transmit 128-channel selection enable bit works in conjunction with the RMCME bit. Normal 32-channel selection is enabled. Six additional registers (XCER1-XCER3) are used to enable 128-channel selection. |
| 24-23 | XPBBLK | 0-3h 0 1h 2h 3h | Transmit partition B subframe bit. Enables 16 contiguous channels in each subframe. Subframe 1. Channel 16 to channel 31 Subframe 3. Channel 48 to channel 63 Subframe 5. Channel 80 to channel 95 Subframe 7. Channel 112 to channel 127 |
| 22-21 | XPABLK | 0-3h 0 1h 2h 3h | Transmit partition A subframe bit. Enables 16 contiguous channels in each subframe. Subframe 0. Channel 0 to channel 15 Subframe 2. Channel 32 to channel 47 Subframe 4. Channel 64 to channel 79 Subframe 6. Channel 96 to channel 111 |
| 20-18 | XCBLK | 0-7h 0 1h 2h 3h 4h 5h 6h 7h | Transmit current subframe bit. Subframe 0. Channel 0 to channel 15 Subframe 1. Channel 16 to channel 31 Subframe 2. Channel 32 to channel 47 Subframe 3. Channel 48 to channel 63 Subframe 4. Channel 64 to channel 79 Subframe 5. Channel 80 to channel 95 Subframe 6. Channel 96 to channel 111 Subframe 7. Channel 112 to channel 127 |
| 17-16 | XMCM | 0-3h 0 1h 2h 3h | Transmit multichannel selection enable bit. All channels are enabled without masking (DX is always driven during transmission of data). DX is masked or driven to a high-impedance state during (a) interpacket intervals, (b) when a channel is masked regardless of whether it is enabled, or (c) when a channel is disabled. All channels are disabled and, therefore, masked by default. Required channels are selected by enabling XP[A/B]BLK and XCER[A/B] appropriately. Also, these selected channels are not masked and, therefore, DX is always driven. All channels are enabled, but masked. Selected channels enabled using XP[A/B]BLK and XCER[A/B] are unmasked. All channels are disabled and, therefore, masked by default. Required channels are selected by enabling RP[A/B]BLK and RCER[A/B] appropriately. Selected channels can be unmasked by RP[A/B]BLK and XCER[A/B]. This mode is used for symmetric transmit and receive operation. |

Table 23. Multichannel Control Register (MCR) Field Descriptions (continued)

| Bit | Field | Value | Description |
|-------|----------|---|---|
| 15-10 | Reserved | 0 | Reserved. The reserved bit location is always read as 0. A value written to this field has no effect. |
| 9 | RMCME | 0 1 | Receive 128-channel selection enable bit works in conjunction with the XMCME bit. Normal 32-channel selection is enabled. Six additional registers (RCER1-RCER3) are used to enable 128-channel selection. |
| 8-7 | RPBBLK | 0-3h 0 1h 2h 3h | Receive partition B subframe bit. Enables 16 contiguous channels in each subframe. Subframe 1. Channel 16 to channel 31 Subframe 3. Channel 48 to channel 63 Subframe 5. Channel 80 to channel 95 Subframe 7. Channel 112 to channel 127 |
| 6-5 | RPABLK | 0-3h 0 1h 2h 3h | Receive partition A subframe bit. Enables 16 contiguous channels in each subframe. Subframe 0. Channel 0 to channel 15 Subframe 2. Channel 32 to channel 47 Subframe 4. Channel 64 to channel 79 Subframe 6. Channel 96 to channel 111 |
| 4-2 | RCBLK | 0-7h 0 1h 2h 3h 4h 5h 6h 7h | Receive current subframe bit. Subframe 0. Channel 0 to channel 15 Subframe 1. Channel 16 to channel 31 Subframe 2. Channel 32 to channel 47 Subframe 3. Channel 48 to channel 63 Subframe 4. Channel 64 to channel 79 Subframe 5. Channel 80 to channel 95 Subframe 6. Channel 96 to channel 111 Subframe 7. Channel 112 to channel 127 |
| 1 | Reserved | 0 | Reserved. The reserved bit location is always read as 0. A value written to this field has no effect. |
| 0 | RMCM | 0 1 | Receive multichannel selection enable bit. All 128 channels are enabled. All channels are disabled by default. Required channels are selected by enabling RP[A/B]BLK and RCER[A/B] appropriately. |

11.8 Receive Channel Enable Register (RCER)

The receive channel enable register (RCER) is used to enable any of the 32 elements for a receive. Of the 32 elements, 16 belong to a subframe in partition A and the other 16 belong to a subframe in partition B. The RCEA and RCEB fields in RCER enable elements within the 16-channel elements in partitions A and B, respectively. The RPABLK and RPBBLK bits in MCR determine which 16-element subframes are selected.

The receive channel enable register (RCER) is shown in [Figure 59](#) and described in [Table 24](#).

Figure 59. Receive Channel Enable Register (RCER)

| | | |
|----|-------|----|
| 31 | RCEB | 16 |
| | R/W-0 | |
| 15 | RCEA | 0 |
| | R/W-0 | |

LEGEND: R/W = Read/Write; -n = value after reset

Table 24. Receive Channel Enable Register (RCER) Field Descriptions

| Bit | Field | Value | Description |
|-------|-------|--------------|--|
| 31-16 | RCEB | 0-FFFFh 0 | A 16-bit unsigned value used to disable (bit value = 0) or enable (bit value = 1) reception of the <i>n</i> th channel within the odd-numbered 16-channel-wide subframe in partition B. The 16-channel-wide subframe is selected by the RPBBLK bit in MCR. Reception to the <i>n</i> th channel is disabled. |
| 15-0 | RCEA | 0-FFFFh 0 | A 16-bit unsigned value used to disable (bit value = 0) or enable (bit value = 1) reception of the <i>n</i> th channel within the even-numbered 16-channel-wide subframe in partition A. The 16-channel-wide subframe is selected by the RPABLK bit in MCR. Reception of the <i>n</i> th channel is disabled. |

11.9 Transmit Channel Enable Registers (XCER)

The transmit channel enable register (XCER) is used to enable any of the 32 elements for a transmit. Of the 32 elements, 16 belong to a subframe in partition A and the other 16 belong to a subframe in partition B. The XCEA and XCEB fields in XCER enable elements within the 16-channel elements in partitions A and B, respectively. The XPABLK and XPBBLK bits in MCR determine which 16-element subframes are selected.

The transmit channel enable registers (XCER) are shown in [Figure 60](#) and described in [Table 25](#).

Figure 60. Transmit Channel Enable Registers (XCER)



LEGEND: R/W = Read/Write; -n = value after reset

Table 25. Transmit Channel Enable Register (XCER) Field Descriptions

| Bit | Field | Value | Description |
|-------|-------|------------------|--|
| 31-16 | XCEB | 0-FFFFh 0 | A 16-bit unsigned value used to disable (bit value = 0) or enable (bit value = 1) transmission of the <i>n</i> th channel within the odd-numbered 16-channel-wide subframe in partition B. The 16-channel-wide subframe is selected by the XPBBLK bit in MCR. Transmission of the <i>n</i> th channel is disabled. |
| 15-0 | XCEA | 0-FFFFh 0 | A 16-bit unsigned value used to disable (bit value = 0) or enable (bit value = 1) transmission of the <i>n</i> th channel within the even-numbered 16-channel-wide subframe in partition A. The 16-channel-wide subframe is selected by the XPABLK bit in MCR. Transmission of the <i>n</i> th channel is disabled. |

11.10 Enhanced Receive Channel Enable Registers (RCERE0-3)

Table 27 shows the 128 channels in a multichannel data stream and their corresponding enable bits in RCEREn.

Each McBSP has four receive channel enable registers of the format shown in Figure 61 (RCERE0, RCERE1, RCERE2, and RCERE3). These four registers are used to enable any of 128 elements for receive.

Table 26 provides a summary description that applies to any bit x of a receive channel enable register.

These I/O-mapped registers are only used when the receiver is configured to allow individual enabling and disabling of the channels (RMCM = 1).

Figure 61. Format of the Enhanced Receive Channel Enable Registers (RCERE0-3)

| | | | | | | | |
|----------|----------|----------|----------|----------|----------|---------|---------|
| 31 | 30 | 29 | 28 | 27 | 26 | 25 | 24 |
| RCERyz15 | RCERyz14 | RCERyz13 | RCERyz12 | RCERyz11 | RCERyz10 | 9 | 8 |
| R/W-0 | R/W-0 | R/W-0 | R/W-0 | R/W-0 | R/W-0 | R/W-0 | R/W-0 |
| 23 | 22 | 21 | 20 | 19 | 18 | 17 | 16 |
| RCERyz7 | RCERyz6 | RCERyz5 | RCERyz4 | RCERyz3 | RCERyz2 | RCERyz1 | RCERyz0 |
| R/W-0 | R/W-0 | R/W-0 | R/W-0 | R/W-0 | R/W-0 | R/W-0 | R/W-0 |
| 15 | 14 | 13 | 12 | 11 | 10 | 9 | 8 |
| RCERxz15 | RCERxz14 | RCERxz13 | RCERxz12 | RCERxz11 | RCERxz10 | RCERxz9 | RCERxz8 |
| R/W-0 | R/W-0 | R/W-0 | R/W-0 | R/W-0 | R/W-0 | R/W-0 | R/W-0 |
| 7 | 6 | 5 | 4 | 3 | 2 | 1 | 0 |
| RCERxz7 | RCERxz6 | RCERxz5 | RCERxz4 | RCERxz3 | RCERxz2 | RCERxz1 | RCERxz0 |
| R/W-0 | R/W-0 | R/W-0 | R/W-0 | R/W-0 | R/W-0 | R/W-0 | R/W-0 |

LEGEND: R = Read only; R/W = Read/ Write; -n = value after reset

Table 26. Format of the Enhanced Receive Channel Enable Registers (RCERE0-3) Field Descriptions

| Bit | Field | Value | Description |
|-------|-------|-------|--|
| 31-16 | RCEx | | Receive channel enable bit For receive multichannel selection mode (RMCM = 1): |
| | | 0 | Disable the channel that is mapped to RCEx. |
| | | 1 | Enable the channel that is mapped to RCEx. |

11.10.1 RCEREs Used in the Receive Multichannel Selection Mode

For multichannel selection operation, the assignment of channels to the RCEREs depends on whether 32 or 128 channels are individually selectable, as defined by the RMCME bit. For each of these two cases,

Table 27 shows which block of channels is assigned to each of the RCEREs used. For each RCER, Table 27 shows which channel is assigned to each of the bits.

Table 27. Use of the Enhanced Receive Channel Enable Registers

| Number of Selectable Channels | Block Assignments | | Channel Assignments | |
|-------------------------------|-------------------|--|---------------------|---------------------------------|
| | RCEREx | Block Assigned ⁽¹⁾ | Bit in RCEREx | Channel Assigned ⁽¹⁾ |
| 32 (RMCME = 0) | RCERE0 | Channels n to (n+15) | RCE0 | Channel n |
| | | | RCE1 | Channel (n+1) |
| | | The block of channels is chosen with the RPABLK bits | RCE2 | Channel (n+2) |
| | | | - | |
| | | Channels m to (m+15) | RCE15 | Channel (n+15) |
| | | | RCE16 | Channel m |
| | | The block of channels is chosen with the RPBBLK bits | RCE17 | Channel (m+1) |
| | | | RCE18 | Channel (m+2) |
| | | - | | |
| | | RCE31 | Channel (m+15) | |
| 128 (RMCME = 1) | RCERE0 | Block 0 | RCE0 | Channel |
| | | | RCE1 | Channel 1 |
| | | | RCE2 | Channel 2 |
| | | | - | |
| | | | RCE15 | Channel 15 |
| | | | RCE16 | Channel 16 |
| | | Block 1 | RCE17 | Channel 17 |
| | | | RCE18 | Channel 18 |
| | | - | | |
| | | RCE31 | Channel 31 | |
| | RCERE1 | Block 2 | RCE0 | Channel 32 |
| | | | RCE1 | Channel 33 |
| | | | RCE2 | Channel 34 |
| | | | - | |
| | | | RCE15 | Channel 47 |
| | | | RCE16 | Channel 48 |
| | | Block 3 | RCE17 | Channel 49 |
| | | | RCE18 | Channel 50 |
| | | - | | |
| | | RCE31 | Channel 63 | |
| RCERE2 | Block 4 | RCE0 | Channel 64 | |
| | | RCE1 | Channel 65 | |
| | | RCE2 | Channel 66 | |
| | | - | | |
| | | RCE15 | Channel 79 | |
| | | | | |

⁽¹⁾ n is any even numbered clock 0, 2, 4, or 6. m is any odd numbered block 1, 3, 5, or 7.

Table 27. Use of the Enhanced Receive Channel Enable Registers (continued)

| Number of Selectable Channels | Block Assignments | | Channel Assignments | |
|-------------------------------|-------------------|-------------------------------|---------------------|---------------------------------|
| | RCEREx | Block Assigned ⁽¹⁾ | Bit in RCEREx | Channel Assigned ⁽¹⁾ |
| | | Block 5 | RCE16 | Channel 80 |
| | | | RCE17 | Channel 81 |
| | | | RCE18 | Channel 82 |
| | | | - | |
| | | | RCE31 | Channel 95 |
| | RCERE3 | Block 6 | RCE0 | Channel 96 |
| | | | RCE1 | Channel 97 |
| | | | RCE2 | Channel 98 |
| | | | - | |
| | | | RCE15 | Channel 111 |
| | | Block 7 | RCE16 | Channel 112 |
| | | | RCE17 | Channel 113 |
| | | | RCE18 | Channel 114 |
| | | | - | |
| | | | RCE31 | Channel 127 |

RCERE0 is the only register used in normal mode (up to 32 channels can be selected in Partitions A and B, RMCME = XMCME = 0 in MCR). All four registers are used when in enhanced mode (up to 128 channels can be selected in all Partitions, RMCME = XMCME = 1 in MCR).

11.11 Enhanced Transmit Channel Enable Registers (XCERE0-3)

Each McBSP has four transmit channel enable registers of the form shown in [Figure 62](#).

[Table 28](#) provides a summary description that applies to each bit XCE_x of a transmit channel enable register. The I/O-mapped XCERs are only used when the transmitter is configured to allow individual disabling/enabling and masking/unmasking of the channels (XMCM is nonzero).

Figure 62. Format of the Enhanced Transmit Channel Enable Registers (XCERE0-3)

| | | | | | | | |
|---------|---------|---------|---------|---------|---------|--------|--------|
| 31 | 30 | 29 | 28 | 27 | 26 | 25 | 24 |
| XCEyz15 | XCEyz14 | XCEyz13 | XCEyz12 | XCEyz11 | XCEyz10 | XCEyz9 | XCEyz8 |
| R/W-0 | R/W-0 | R/W-0 | R/W-0 | R/W-0 | R/W-0 | R/W-0 | R/W-0 |
| 23 | 22 | 21 | 20 | 19 | 18 | 17 | 16 |
| XCEyz7 | XCEyz6 | XCEyz5 | XCEyz4 | XCEyz3 | XCEyz2 | XCEyz1 | XCEyz0 |
| R/W-0 | R/W-0 | R/W-0 | R/W-0 | R/W-0 | R/W-0 | R/W-0 | R/W-0 |
| 15 | 14 | 13 | 12 | 11 | 10 | 9 | 8 |
| XCExz15 | XCExz14 | XCExz13 | XCExz12 | XCExz11 | XCExz10 | XCExz9 | XCExz8 |
| R/W-0 | R/W-0 | R/W-0 | R/W-0 | R/W-0 | R/W-0 | R/W-0 | R/W-0 |
| 7 | 6 | 5 | 4 | 3 | 2 | 1 | 0 |
| XCExz7 | XCExz6 | XCExz5 | XCExz4 | XCExz3 | XCExz2 | XCExz1 | XCExz0 |
| R/W-0 | R/W-0 | R/W-0 | R/W-0 | R/W-0 | R/W-0 | R/W-0 | R/W-0 |

LEGEND: R = Read only; R/W = Read/ Write; -n = value after reset

Table 28. Description for Bit x of a Transmit Channel Enable Register (XCERE0-3) Field Descriptions

| Bit | Field | Value | Description |
|------|------------------|-------|---|
| 31-0 | XCE _x | | Transmit channel enable bit. The role of this bit depends on which transmit multichannel mode is selected with the XMCM bits. |
| | | 0 | Disable and mask the channel that is mapped to XCE _x . |
| | | 1 | Enable and unmask the channel that is mapped to XCE _x . |
| | | | For multichannel selection mode when XMCM = 01b (all channels disabled unless selected): |
| | | 0 | Mask the channel that is mapped to XCE _x . |
| | | 1 | Unmask the channel that is mapped to XCE _x . |
| | | | For multichannel selection mode when XMCM = 10b (all channels enabled but masked unless selected): |
| | | 0 | Mask the channel that is mapped to XCE _x . Even if this channel is enabled by the corresponding receive channel enable bit, this channel's data cannot appear on the DX pin. |
| | | 1 | Unmask the channel that is mapped to XCE _x . Even if this channel is also enabled by the corresponding receive channel enable bit, full transmission can occur. |

11.11.1 XCEREs Used in a Transmit Multichannel Selection Mode

For multichannel selection operation, the assignment of channels to the XCEREs depends on whether 32 or 128 channels are individually selectable, as defined by the XMCM bit. These two cases are shown in Table 29. Table 29 shows which block of channels is assigned to each XCER that is used. For each XCER, Table 29 shows which channel is assigned to each of the bits.

NOTE: When XMCM = 11b (for symmetric transmission and reception), the transmitter uses the receive channel enable registers (RCERs) to enable channels and uses the XCERs to unmask channels for transmission.

Table 29. Use of the Enhanced Transmit Channel Enable Registers

| Number of Selectable Channels | Block Assignments | | Channel Assignments | | |
|-------------------------------|-------------------|---|--|---------------------------------|---------------|
| | XCEREx | Block Assigned ⁽¹⁾ | Bit in XCEREx | Channel Assigned ⁽¹⁾ | |
| 32 (XMCM = 0) | XCERE0 | Channels n to (n+15) | XCE0 | Channel n | |
| | | When XMCM = 01b or 10b, the block of channels is chosen with the XPABLK bits. | XCE1 | Channel (n+1) | |
| | | | XCE2 | Channel (n+2) | |
| | | | XCE3 | Channel (n+3) | |
| | | | XCE4 | Channel (n+4) | |
| | | | XCE5 | Channel (n+5) | |
| | | | XCE6 | Channel (n+6) | |
| | | | XCE7 | Channel (n+7) | |
| | | | XCE8 | Channel (n+8) | |
| | | | XCE9 | Channel (n+9) | |
| | | | XCE10 | Channel (n+10) | |
| | | XCE11 | Channel (n+11) | | |
| | | XCE12 | Channel (n+12) | | |
| | | XCE13 | Channel (n+13) | | |
| | | XCE14 | Channel (n+14) | | |
| | | XCE15 | Channel (n+15) | | |
| | | Channels m to (m+15) | XCE16 | Channel m | |
| | | When XMCM = 01b or 10b, the block of channels is chosen with the XPBBLK bits. | XCE17 | Channel (m+1) | |
| | | | When XMCM = 11b, the block is chosen with the RPBBLK bits. | XCE18 | Channel (m+2) |
| | | | | XCE19 | Channel (m+3) |
| | | | | XCE20 | Channel (m+4) |
| | | | | XCE21 | Channel (m+5) |
| XCE22 | Channel (m+6) | | | | |

⁽¹⁾ n is any even numbered clock 0, 2, 4, or 6. m is any odd numbered block 1, 3, 5, or 7.

Table 29. Use of the Enhanced Transmit Channel Enable Registers (continued)

| Number of Selectable Channels | Block Assignments | | Channel Assignments | |
|-------------------------------|-------------------|-------------------------------|---------------------|---------------------------------|
| | XCEREx | Block Assigned ⁽¹⁾ | Bit in XCEREx | Channel Assigned ⁽¹⁾ |
| | | | XCE23 | Channel (m+7) |
| | | | XCE24 | Channel (m+8) |
| | | | XCE25 | Channel (m+9) |
| | | | XCE26 | Channel (m+10) |
| | | | XCE27 | Channel (m+11) |
| | | | XCE28 | Channel (m+12) |
| | | | XCE29 | Channel (m+13) |
| | | | XCE30 | Channel (m+14) |
| | | | XCE31 | Channel (m+15) |
| 128 (XMCME = 1) | XCERE0 | Block 0 | XCE0 | Channel |
| | | | XCE1 | Channel 1 |
| | | | XCE2 | Channel 2 |
| | | | XCE3 | Channel 3 |
| | | | XCE4 | Channel 4 |
| | | | XCE5 | Channel 5 |
| | | | XCE6 | Channel 6 |
| | | | XCE7 | Channel 7 |
| | | | XCE8 | Channel 8 |
| | | | XCE9 | Channel 9 |
| | | | XCE10 | Channel 10 |
| | | | XCE11 | Channel 11 |
| | | | XCE12 | Channel 12 |
| | | | XCE13 | Channel 13 |
| | | | XCE14 | Channel 14 |
| | | | XCE15 | Channel 15 |
| | | Block 1 | XCE16 | Channel 16 |
| | | | XCE17 | Channel 17 |
| | | | XCE18 | Channel 18 |
| | | | XCE19 | Channel 19 |
| | | | XCE20 | Channel 20 |
| | | | XCE21 | Channel 21 |
| | | | XCE22 | Channel 22 |
| | | | XCE23 | Channel 23 |
| | | | XCE24 | Channel 24 |
| | | | XCE25 | Channel 25 |
| | | | XCE26 | Channel 26 |
| | | | XCE27 | Channel 27 |
| | | | XCE28 | Channel 28 |
| | | | XCE29 | Channel 29 |
| | | | XCE30 | Channel 30 |
| | | | XCE31 | Channel 31 |

Table 29. Use of the Enhanced Transmit Channel Enable Registers (continued)

| Number of Selectable Channels | Block Assignments | | Channel Assignments | |
|-------------------------------|-------------------|-------------------------------|---------------------|---------------------------------|
| | XCEREx | Block Assigned ⁽¹⁾ | Bit in XCEREx | Channel Assigned ⁽¹⁾ |
| | XCERE1 | Block 2 | XCE0 | Channel 32 |
| | | | XCE1 | Channel 33 |
| | | | XCE2 | Channel 34 |
| | | | XCE3 | Channel 35 |
| | | | XCE4 | Channel 36 |
| | | | XCE5 | Channel 37 |
| | | | XCE6 | Channel 38 |
| | | | XCE7 | Channel 39 |
| | | | XCE8 | Channel 40 |
| | | | XCE9 | Channel 41 |
| | | | XCE10 | Channel 42 |
| | | | XCE11 | Channel 43 |
| | | | XCE12 | Channel 44 |
| | | | XCE13 | Channel 45 |
| | | | XCE14 | Channel 46 |
| | | | XCE15 | Channel 47 |
| | | Block 3 | XCE16 | Channel 48 |
| | | | XCE17 | Channel 49 |
| | | | XCE18 | Channel 50 |
| | | | XCE19 | Channel 51 |
| | | | XCE20 | Channel 52 |
| | | | XCE21 | Channel 53 |
| | | | XCE22 | Channel 54 |
| | | | XCE23 | Channel 55 |
| | | | XCE24 | Channel 56 |
| | | | XCE25 | Channel 57 |
| | | | XCE26 | Channel 58 |
| | | | XCE27 | Channel 59 |
| | | | XCE28 | Channel 60 |
| | | | XCE29 | Channel 61 |
| | | | XCE30 | Channel 62 |
| | | | XCE31 | Channel 63 |

Table 29. Use of the Enhanced Transmit Channel Enable Registers (continued)

| Number of Selectable Channels | Block Assignments | | Channel Assignments | |
|-------------------------------|-------------------|-------------------------------|---------------------|---------------------------------|
| | XCEREx | Block Assigned ⁽¹⁾ | Bit in XCEREx | Channel Assigned ⁽¹⁾ |
| | XCERE2 | Block 4 | XCE0 | Channel 64 |
| | | | XCE1 | Channel 65 |
| | | | XCE2 | Channel 66 |
| | | | XCE3 | Channel 67 |
| | | | XCE4 | Channel 68 |
| | | | XCE5 | Channel 69 |
| | | | XCE6 | Channel 70 |
| | | | XCE7 | Channel 71 |
| | | | XCE8 | Channel 72 |
| | | | XCE9 | Channel 73 |
| | | | XCE10 | Channel 74 |
| | | | XCE11 | Channel 75 |
| | | | XCE12 | Channel 76 |
| | | | XCE13 | Channel 77 |
| | XCE14 | Channel 78 | | |
| | Block 5 | XCE15 | Channel 79 | |
| | | XCE16 | Channel 80 | |
| | | XCE17 | Channel 81 | |
| | | XCE18 | Channel 82 | |
| | | XCE19 | Channel 83 | |
| | | XCE20 | Channel 84 | |
| | | XCE21 | Channel 85 | |
| | | XCE22 | Channel 86 | |
| | | XCE23 | Channel 87 | |
| | | XCE24 | Channel 88 | |
| | | XCE25 | Channel 89 | |
| | | XCE26 | Channel 90 | |
| | | XCE27 | Channel 91 | |
| | | XCE28 | Channel 92 | |
| | | XCE29 | Channel 93 | |
| | | XCE30 | Channel 94 | |
| XCE31 | | Channel 95 | | |

Table 29. Use of the Enhanced Transmit Channel Enable Registers (continued)

| Number of Selectable Channels | Block Assignments | | Channel Assignments | |
|-------------------------------|-------------------|-------------------------------|---------------------|---------------------------------|
| | XCEREx | Block Assigned ⁽¹⁾ | Bit in XCEREx | Channel Assigned ⁽¹⁾ |
| | XCERE3 | Block 6 | XCE0 | Channel 96 |
| | | | XCE1 | Channel 97 |
| | | | XCE2 | Channel 98 |
| | | | XCE3 | Channel 99 |
| | | | XCE4 | Channel 100 |
| | | | XCE5 | Channel 101 |
| | | | XCE6 | Channel 102 |
| | | | XCE7 | Channel 103 |
| | | | XCE8 | Channel 104 |
| | | | XCE9 | Channel 105 |
| | | | XCE10 | Channel 106 |
| | | | XCE11 | Channel 107 |
| | | | XCE12 | Channel 108 |
| | | | XCE13 | Channel 109 |
| | | | XCE14 | Channel 110 |
| | | | XCE15 | Channel 111 |
| | | Block 7 | XCE16 | Channel 112 |
| | | | XCE17 | Channel 113 |
| | | | XCE18 | Channel 114 |
| | | | XCE19 | Channel 115 |
| | | | XCE20 | Channel 116 |
| | | | XCE21 | Channel 117 |
| | | | XCE22 | Channel 118 |
| | | | XCE23 | Channel 119 |
| | | | XCE24 | Channel 120 |
| | | | XCE25 | Channel 121 |
| | | | XCE26 | Channel 122 |
| | | | XCE27 | Channel 123 |
| | | | XCE28 | Channel 124 |
| | | | XCE29 | Channel 125 |
| | | | XCE30 | Channel 126 |
| | | | XCE31 | Channel 127 |

11.12 Pin Control Register (PCR)

The serial port is configured via the serial port control register (SPCR) and the pin control register (PCR). The PCR is also used to configure the serial port pins as general-purpose inputs or outputs during receiver and/or transmitter reset (for more information, see [Section 10](#)). The PCR contains McBSP status control bits.

The PCR is shown in [Figure 63](#) and described in [Table 30](#).

Figure 63. Pin Control Register (PCR)

| | | | | | | | | | |
|-------------------------|----------|--------|--------|-------|-------|-------|-------|--|----|
| 31 | Reserved | | | | | | | | 16 |
| R-0 | | | | | | | | | |
| 15 | 14 | 13 | 12 | 11 | 10 | 9 | 8 | | |
| Reserved | | XIOEN | RIOEN | FSXM | FSRM | CLKXM | CLKRM | | |
| R-0 | | R/W-0 | R/W-0 | R/W-0 | R/W-0 | R/W-0 | R/W-0 | | |
| 7 | 6 | 5 | 4 | 3 | 2 | 1 | 0 | | |
| Reserved ^(A) | CLKSSTAT | DXSTAT | SRSTAT | FSXP | FSRP | CLKXP | CLKRP | | |
| R-0 | R-0 | R/W-0 | R-0 | R/W-0 | R/W-0 | R/W-0 | R/W-0 | | |

LEGEND: R = Read only; R/W = Read/Write; -n = value after reset

A. If writing to this field, always write the default value of 0 to ensure proper McBSP operation.

Table 30. Pin Control Register (PCR) Field Descriptions

| Bit | Field | Value | Description |
|-------|----------|-------|--|
| 31-14 | Reserved | 0 | Reserved. The reserved bit location is always read as 0. A value written to this field has no effect. |
| 13 | XIOEN | 0 | Transmit general-purpose I/O mode only when transmitter is disabled (XRST = 0 in SPCR). DX, FSX, and CLKX pins are configured as serial port pins and do not function as general-purpose I/O pins. |
| | | 1 | DX pin is configured as general-purpose output pin; FSX and CLKX pins are configured as general-purpose I/O pins. These serial port pins do not perform serial port operations. |
| 12 | RIOEN | 0 | Receive general-purpose I/O mode only when receiver is disabled (RRST = 0 in SPCR). DR, FSR, CLKR, and CLKS pins are configured as serial port pins and do not function as general-purpose I/O pins. |
| | | 1 | DR and CLKS pins are configured as general-purpose input pins; FSR and CLKR pins are configured as general-purpose I/O pins. These serial port pins do not perform serial port operations. |
| 11 | FSXM | 0 | Transmit frame-synchronization mode bit. Frame-synchronization signal is derived from an external source. |
| | | 1 | Frame-synchronization signal is determined by FSGM bit in SRGR. |
| 10 | FSRM | 0 | Receive frame-synchronization mode bit. Frame-synchronization signal is derived from an external source. FSR is an input pin. |
| | | 1 | Frame-synchronization signal is generated internally by the sample-rate generator. FSR is an output pin, except when GSYNC = 1 in SRGR. |
| 9 | CLKXM | 0 | Transmitter clock mode bit. CLKX is an input pin and is driven by an external clock. |
| | | 1 | CLKX is an output pin and is driven by the internal sample-rate generator. |
| | | 0 | In SPI mode when CLKSTP in SPCR is a non-zero value: MCBSP is a slave and clock (CLKX) is driven by the SPI master in the system. CLKR is internally driven by CLKX. |
| | | 1 | MCBSP is a master and generates the clock (CLKX) to drive its receive clock (CLKR) and the shift clock of the SPI-compliant slaves in the system. |

Table 30. Pin Control Register (PCR) Field Descriptions (continued)

| Bit | Field | Value | Description |
|-----|----------|-------|---|
| 8 | CLKRM | | Receiver clock mode bit. |
| | | 0 | Digital loop back mode is disabled (DLB = 0 in SPCR): CLKR is an input pin and is driven by an external clock. |
| | | 1 | CLKR is an output pin and is driven by the internal sample-rate generator. |
| | | | Digital loop back mode is enabled (DLB = 1 in SPCR): |
| | | 0 | Receive clock (not the CLKR pin) is driven by transmit clock (CLKX) that is based on CLKXM bit. CLKR pin is in high-impedance state. |
| | | 1 | CLKR is an output pin and is driven by the transmit clock. The transmit clock is based on CLKXM bit. |
| 7 | Reserved | 0 | Reserved. The reserved bit location is always read as 0. A value written to this field has no effect. If writing to this field, always write the default value of 0 to ensure proper McBSP operation. |
| 6 | CLKSSTAT | | CLKS pin status reflects value on CLKS pin when configured as a general-purpose input pin. |
| | | 0 | CLKS pin reflects a logic low. |
| | | 1 | CLKS pin reflects a logic high. |
| 5 | DXSTAT | | DX pin status reflects value driven to DX pin when configured as a general-purpose output pin. |
| | | 0 | DX pin reflects a logic low. |
| | | 1 | DX pin reflects a logic high. |
| 4 | DRSTAT | | DR pin status reflects value on DR pin when configured as a general-purpose input pin. |
| | | 0 | DR pin reflects a logic low. |
| | | 1 | DR pin reflects a logic high. |
| 3 | FSXP | | Transmit frame-synchronization polarity bit. |
| | | 0 | Transmit frame-synchronization pulse is active high. |
| | | 1 | Transmit frame-synchronization pulse is active low. |
| 2 | FSRP | | Receive frame-synchronization polarity bit. |
| | | 0 | Receive frame-synchronization pulse is active high. |
| | | 1 | Receive frame-synchronization pulse is active low. |
| 1 | CLKXP | | Transmit clock polarity bit. |
| | | 0 | Transmit data sampled on rising edge of CLKX. |
| | | 1 | Transmit data sampled on falling edge of CLKX. |
| 0 | CLKRP | | Receive clock polarity bit. |
| | | 0 | Receive data sampled on falling edge of CLKR. |
| | | 1 | Receive data sampled on rising edge of CLKR. |

Appendix A Revision History

This revision history highlights the technical changes made to the document in this revision.

Table 31. McBSP Revision History

| See | Additions/Modifications/Deletions |
|-------------------------------|---|
| Section 1 | Modified section |
| Section 3.2.1 | Deleted last sentence |
| Section 3.2.2 | Deleted last sentence |
| Section 3.3 | Changed (R/X)INTM = 00b to Reserved |
| Section 4.5.7 | Modified list items |
| Table 20 | Modified Description for Bits 20-19 and Bit 4 |
| Table 21 | Modified Description for Bits 20-19 and Bit 4 |

IMPORTANT NOTICE

Texas Instruments Incorporated and its subsidiaries (TI) reserve the right to make corrections, modifications, enhancements, improvements, and other changes to its products and services at any time and to discontinue any product or service without notice. Customers should obtain the latest relevant information before placing orders and should verify that such information is current and complete. All products are sold subject to TI's terms and conditions of sale supplied at the time of order acknowledgment.

TI warrants performance of its hardware products to the specifications applicable at the time of sale in accordance with TI's standard warranty. Testing and other quality control techniques are used to the extent TI deems necessary to support this warranty. Except where mandated by government requirements, testing of all parameters of each product is not necessarily performed.

TI assumes no liability for applications assistance or customer product design. Customers are responsible for their products and applications using TI components. To minimize the risks associated with customer products and applications, customers should provide adequate design and operating safeguards.

TI does not warrant or represent that any license, either express or implied, is granted under any TI patent right, copyright, mask work right, or other TI intellectual property right relating to any combination, machine, or process in which TI products or services are used. Information published by TI regarding third-party products or services does not constitute a license from TI to use such products or services or a warranty or endorsement thereof. Use of such information may require a license from a third party under the patents or other intellectual property of the third party, or a license from TI under the patents or other intellectual property of TI.

Reproduction of TI information in TI data books or data sheets is permissible only if reproduction is without alteration and is accompanied by all associated warranties, conditions, limitations, and notices. Reproduction of this information with alteration is an unfair and deceptive business practice. TI is not responsible or liable for such altered documentation. Information of third parties may be subject to additional restrictions.

Resale of TI products or services with statements different from or beyond the parameters stated by TI for that product or service voids all express and any implied warranties for the associated TI product or service and is an unfair and deceptive business practice. TI is not responsible or liable for any such statements.

TI products are not authorized for use in safety-critical applications (such as life support) where a failure of the TI product would reasonably be expected to cause severe personal injury or death, unless officers of the parties have executed an agreement specifically governing such use. Buyers represent that they have all necessary expertise in the safety and regulatory ramifications of their applications, and acknowledge and agree that they are solely responsible for all legal, regulatory and safety-related requirements concerning their products and any use of TI products in such safety-critical applications, notwithstanding any applications-related information or support that may be provided by TI. Further, Buyers must fully indemnify TI and its representatives against any damages arising out of the use of TI products in such safety-critical applications.

TI products are neither designed nor intended for use in military/aerospace applications or environments unless the TI products are specifically designated by TI as military-grade or "enhanced plastic." Only products designated by TI as military-grade meet military specifications. Buyers acknowledge and agree that any such use of TI products which TI has not designated as military-grade is solely at the Buyer's risk, and that they are solely responsible for compliance with all legal and regulatory requirements in connection with such use.

TI products are neither designed nor intended for use in automotive applications or environments unless the specific TI products are designated by TI as compliant with ISO/TS 16949 requirements. Buyers acknowledge and agree that, if they use any non-designated products in automotive applications, TI will not be responsible for any failure to meet such requirements.

Following are URLs where you can obtain information on other Texas Instruments products and application solutions:

| Products | | Applications | |
|-----------------------------|--|----------------------------|--|
| Amplifiers | amplifier.ti.com | Audio | www.ti.com/audio |
| Data Converters | dataconverter.ti.com | Automotive | www.ti.com/automotive |
| DLP® Products | www.dlp.com | Communications and Telecom | www.ti.com/communications |
| DSP | dsp.ti.com | Computers and Peripherals | www.ti.com/computers |
| Clocks and Timers | www.ti.com/clocks | Consumer Electronics | www.ti.com/consumer-apps |
| Interface | interface.ti.com | Energy | www.ti.com/energy |
| Logic | logic.ti.com | Industrial | www.ti.com/industrial |
| Power Mgmt | power.ti.com | Medical | www.ti.com/medical |
| Microcontrollers | microcontroller.ti.com | Security | www.ti.com/security |
| RFID | www.ti-rfid.com | Space, Avionics & Defense | www.ti.com/space-avionics-defense |
| RF/IF and ZigBee® Solutions | www.ti.com/lprf | Video and Imaging | www.ti.com/video |
| | | Wireless | www.ti.com/wireless-apps |