

Should You Power Your Industrial Sensors with a Linear or Switching Regulator?



Stephen Ott

Modern factories feature automated systems that rely on feedback from many sensors across the factory floor to maintain high productivity. These factories use a digital fieldbus to aggregate the enormous amount of data that the sensors collect. The more data that the sensors gather, the better the system can adapt and operate.

As a result, modern fieldbus-connected industrial sensors must detect signals at a faster and more precise rate and output that information as a digital signal versus a conventional analog signal. This functionality requires more powerful processors for the sensors. Plus, because there are more of these sensors in the factory, the form factor is shrinking. The increased power requirements and shrinking form factor are forcing a change from the proven linear regulator solution to a switching regulator solution.

Using a switching regulator poses new challenges. A switching regulator will have a larger form factor because of the additional area that the inductor requires. You must consider the regulator's switching frequency in relation to the frequency of the measurement signal. The layout of the switcher is more critical. A poorly designed switching regulator will raise the noise floor and generate unwanted electromagnetic compatibility (EMC) that will interfere with the detection of small signals.

Fortunately, there are now integrated inductor DC/DC switching regulators available that minimize many of these challenges. Integrating the inductor reduces the switch-node area and makes an optimal layout much easier. The switching frequency of new DC/DC converters has increased significantly, enabling the use of small-chip inductors and ceramic capacitors to make the DC/DC switcher the smallest option.

The new LMZM23601 power module integrates a DC/DC converter, inductor, Vcc filter capacitor and boot capacitor in a 3mm-by-3.8 mm-by-1.6mm package. It can handle input voltages up to 36V and steps down to voltages from 15V to 2.5V (with fixed 5V and 3.3V options) while delivering up to 1A of output current. As you can see in [Figure 1](#), you can realize a complete 1A solution in a minimal amount of board space.

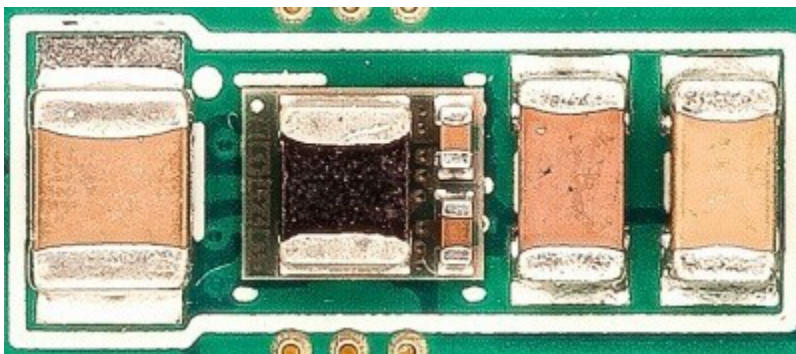

Figure 1. The LMZM23601 Solution for 3.3V or 5V Outputs at up to 1A

Let's take a look at how the LMZM23601 compares to the traditional linear regulator options for a field transmitter application with these requirements:

- Input voltage: 10V to 30V, 24V nominal.
- Output voltage: 3.3V.
- Output current: 35mA.
- Temperature range: -40°C to 85°C ambient.

- Board area: 40mm by 4.5mm.

As [Table 1](#) shows, the LMZM23601 is at an advantage in terms of package area and thermals compared to a linear regulator in a mini small-outline package (MSOP)-8. Note that the $R_{\theta JA}$ specified in [Table 1](#) is only a reference for comparison, since it will be much higher in an actual sensor application given the limited amount of board space and copper. A Joint Electron Device Engineering Council (JEDEC) or an evaluation module (EVM) calculates the typical $R_{\theta JA}$ value found in the data sheet. As an example, the LMZM23601 $R_{\theta JA}$ of 45°C/W is based on a 30mm-by-30mm two-layer board.

Table 1. LMZM23601 vs Linear Regulator Design Options by Package Type

Design option	Package footprint (mm)	Package area (mm ²)	Package thermals $R_{\theta JA}$ (°C/W)
LMZM23601	3 x 3.8	11.4	45
Linear – MSOP-8	5 x 3	15.0	60
Linear – heat-sink thin-shrink small outline package (HTSSOP)	5.1 x 6.6	33.7	39.7
Linear – transistor outline (TO)-252	10.7 x 15.9	169.4	26.9
Linear – TO-263	10.4 x 6.7	69.7	24.7

Looking at [Table 2](#), the linear regulator is dissipating $(24V-3.3V) \times 35mA = \sim 0.93W$ of power, while the LMZM23601 is dissipating only 0.116W. The temperature rise in the MSOP-8 package linear regulator results in a junction temperature above the standard integrated circuit (IC) junction temperature of 125°C, while the junction temperature for the LMZM23601 is 90°C based on a 45°C/W $R_{\theta JA}$. Even multiplying the $R_{\theta JA}$ by a factor of five would still yield a T_j max below the junction temperature.

Table 2. Thermal considerations for a 24V-to-3.3V conversion at 35mA

Design option	Power dissipation (W)	Temperature rise (°C)	Junction temperature (°C)
LMZM23601	0.1155	5.2	90
Linear – MSOP-8	0.9355	56.13	141

From this example, it is clear that a linear regulator is not a viable option in terms of thermals. The trade-off of going with a switching solution (even a module such as the LMZM23601) is that you now must consider the output ripple. As shown in [Figure 2](#), the output ripple from a standard LMZM23601 design for a 3.3V output is about 3mV peak to peak.

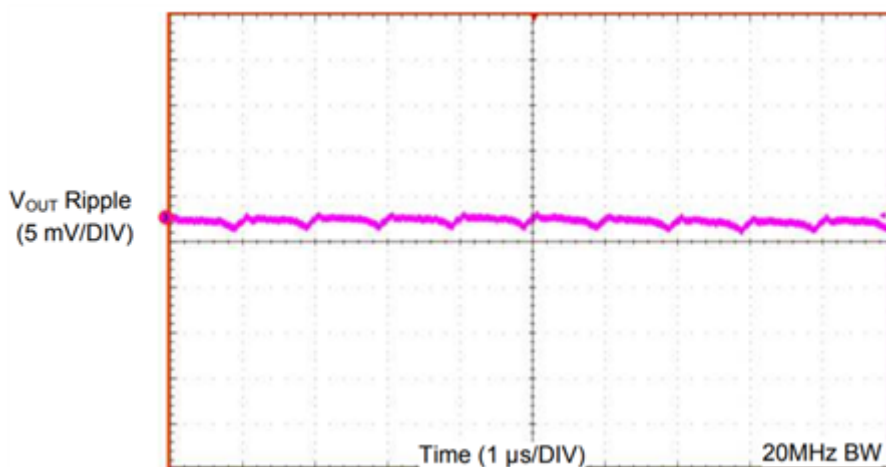

Figure 2. Output Ripple from the LMZM23601EVM for a 3.3V Output

To further reduce the output ripple, you can use a second-stage filter like the one shown in [Figure 3](#). [Figure 4](#) shows that the output ripple has been reduced from 3mV peak to peak to <1mV peak to peak.

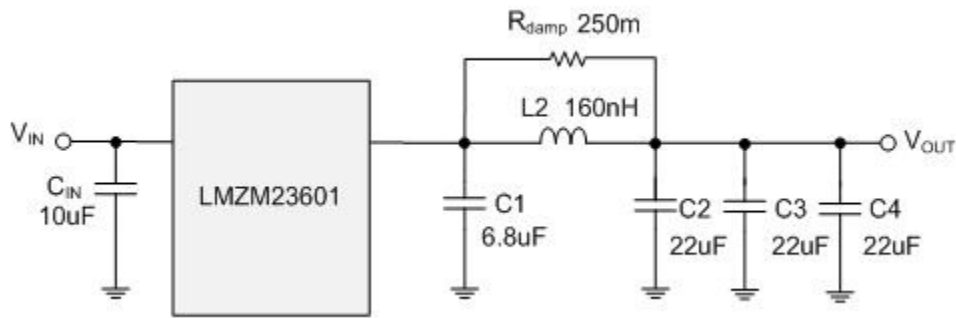

Figure 3. The LMZM23601 with a Second-stage Filter

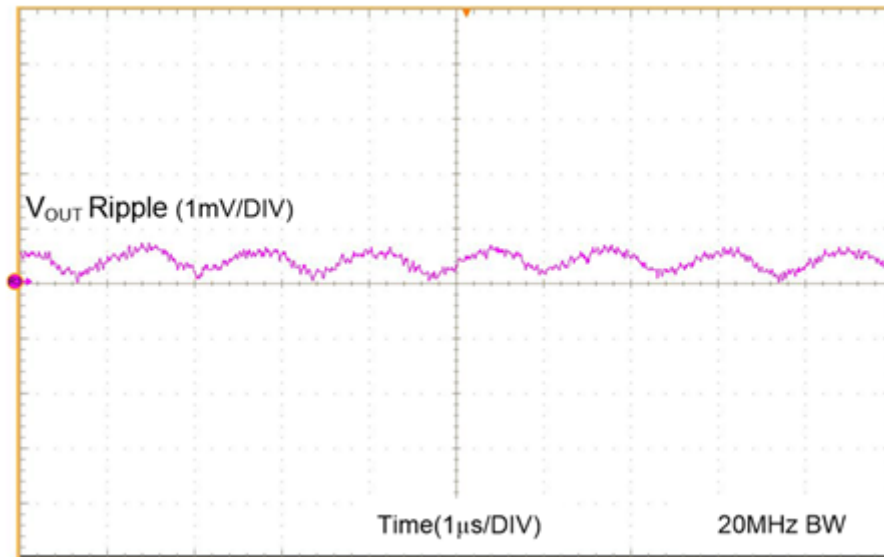

Figure 4. LMZM23601 Output-voltage Ripple with a Second-stage Filter

For industrial sensors with tight board space requirements, a switching regulator is the only viable option. The LMZM23601 integrated inductor delivers high performance in a solution size smaller than a linear regulator, but with the efficiency of a switching regulator.

Additional Resources

- Read the blog: [“Design a second-stage filter for sensitive applications.”](#)
- Download the application report, [“Semiconductor and IC Package Thermal Metrics.”](#)

IMPORTANT NOTICE AND DISCLAIMER

TI PROVIDES TECHNICAL AND RELIABILITY DATA (INCLUDING DATA SHEETS), DESIGN RESOURCES (INCLUDING REFERENCE DESIGNS), APPLICATION OR OTHER DESIGN ADVICE, WEB TOOLS, SAFETY INFORMATION, AND OTHER RESOURCES "AS IS" AND WITH ALL FAULTS, AND DISCLAIMS ALL WARRANTIES, EXPRESS AND IMPLIED, INCLUDING WITHOUT LIMITATION ANY IMPLIED WARRANTIES OF MERCHANTABILITY, FITNESS FOR A PARTICULAR PURPOSE OR NON-INFRINGEMENT OF THIRD PARTY INTELLECTUAL PROPERTY RIGHTS.

These resources are intended for skilled developers designing with TI products. You are solely responsible for (1) selecting the appropriate TI products for your application, (2) designing, validating and testing your application, and (3) ensuring your application meets applicable standards, and any other safety, security, regulatory or other requirements.

These resources are subject to change without notice. TI grants you permission to use these resources only for development of an application that uses the TI products described in the resource. Other reproduction and display of these resources is prohibited. No license is granted to any other TI intellectual property right or to any third party intellectual property right. TI disclaims responsibility for, and you will fully indemnify TI and its representatives against, any claims, damages, costs, losses, and liabilities arising out of your use of these resources.

TI's products are provided subject to [TI's Terms of Sale](#) or other applicable terms available either on [ti.com](https://www.ti.com) or provided in conjunction with such TI products. TI's provision of these resources does not expand or otherwise alter TI's applicable warranties or warranty disclaimers for TI products.

TI objects to and rejects any additional or different terms you may have proposed.

Mailing Address: Texas Instruments, Post Office Box 655303, Dallas, Texas 75265
Copyright © 2023, Texas Instruments Incorporated