

The benefits of extreme precision from buried Zener technology in calibration



Jackson Wightman

Precision test equipment relies on precise data converters to make sure that any measurements taken accurately represent the device under test. For test and measurement, any offset error, gain error or decrease in the effective number of bits will negatively affect the measurements generated. Unfortunately, however, it's not possible to design all of these errors out of a high-precision system. Things like temperature drift or long-term drift will eventually present themselves in the form of a gain or offset error. For this reason, calibration must occur, in order to make sure that any measurements taken are accurate.

For calibration to be effective, there must be unchanging voltage levels available. Colloquially, you might call this a “golden reference.” As the analog-to-digital converter (ADC) or digital-to-analog converter (DAC) measures these known voltage levels, it can compare the results and use any differences to determine the gain and offset error. [Figure 1](#) illustrates an example configuration of this circuit.

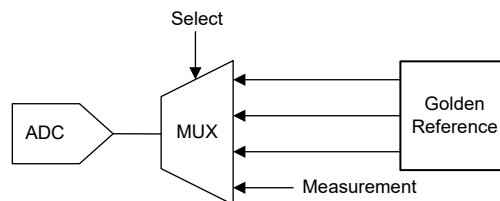

Figure 1. Example circuit configuration for ADC calibration

After quantifying the gain and offset error, software can compensate for the difference. This method of calibration is essential to maintaining accurate measurements for test applications, and it is totally reliant on the golden reference, which gets as close to unchanging as possible. Of course, no circuit is completely unchanging, so even a highly precise voltage reference does exhibit small amounts of drift with time.

Buried Zener diode voltage references and their importance in calibration

A golden reference that shifts with time affects the entire system’s accuracy. Parameters of a golden reference that affect system accuracy include long-term drift, temperature drift and noise.

Selecting a voltage reference that minimizes the errors caused by the parameters listed in Table 1 will lead to the selection of a buried Zener voltage reference that has an internal heater. Buried Zener voltage references provide a voltage level that drifts minimally with time and temperature and has ultra-low noise. An example of such a device is the [REF80](#) from TI. Table 1 also includes some REF80 performance specifications.

Table 1. Voltage reference parameters and REF80 specifications

Voltage reference parameter	Specification
Long-term drift	10ppm (0 to 336 hours) 0.9ppm (336 to 1,000 hours)
Temperature drift	0.05ppm/°C typical 0.2ppm/°C maximum
0.1Hz to 10Hz noise	0.16ppm _{p-p}

0.1Hz to 10Hz noise and temperature drift affect the output of the voltage reference, therefore leading to calibration errors. The most important specification to consider for calibration is long-term drift, however, because that is the parameter that directly affects how often you need to calibrate the entire system.

Increasing time between system calibration in semiconductor test equipment

When calibrating ADCs and DACs throughout test and measurement equipment, a buried Zener voltage reference helps determine how the ADC and DAC output values have shifted. And although buried Zener voltage references shift very little with time, in high-precision test equipment you must still account for even small variations in the output voltage. Many test and measurement systems require calibrating the golden reference after a number of months to ensure that system calibration dependent on the golden reference remains accurate. [Figure 2](#) shows the long-term drift of the REF80.

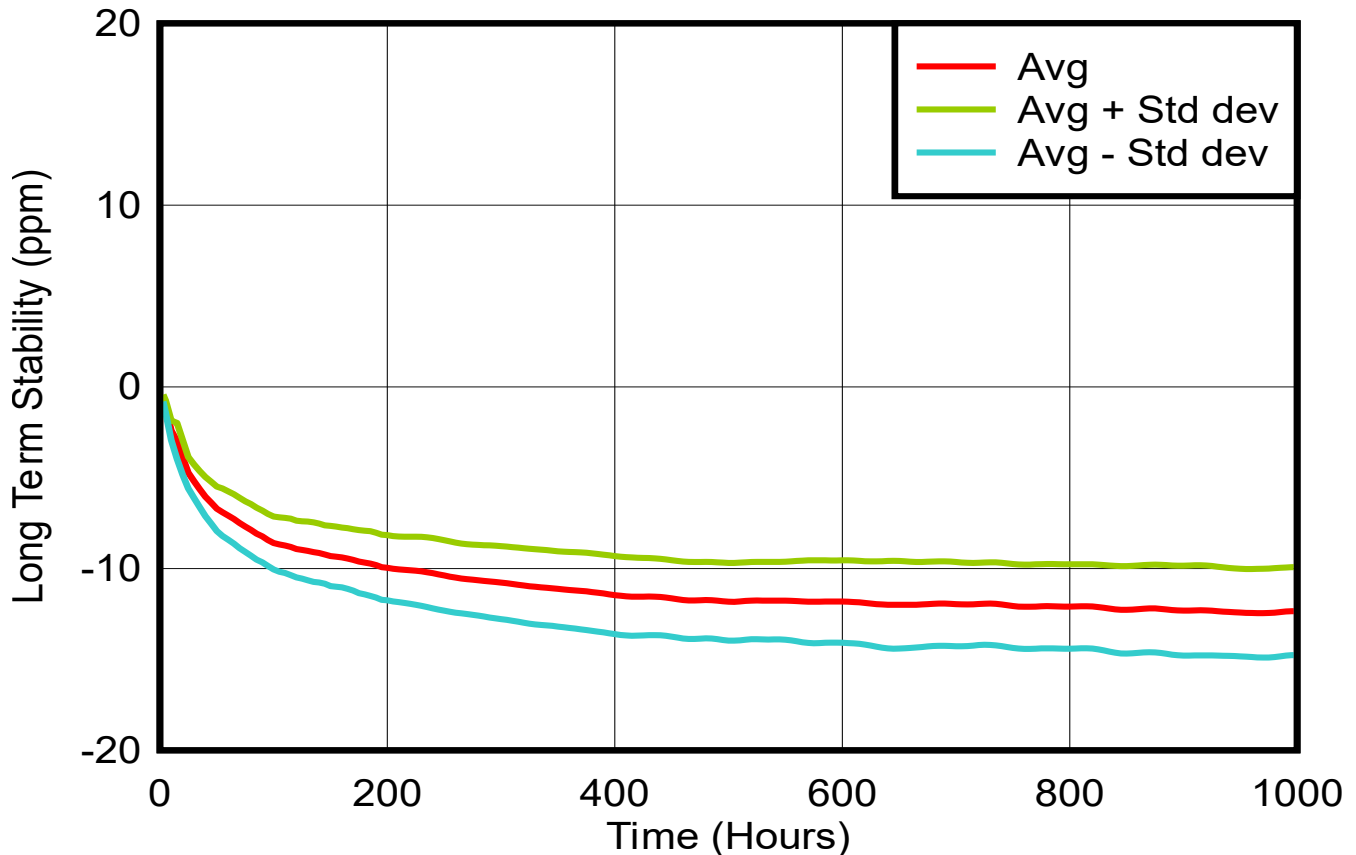

Figure 2. REF80 output voltage long-term drift

There are a few important aspects of Figure 2 that demonstrate why the REF80 is a good fit for the calibration of highly precise test and measurement systems. First, most of the output voltage drift happens in the first 336 hours, or 14 days, of device operation. This is important, because the quicker the output voltage drift settles, the less there is a need for calibration because the output voltage does not drift nearly as much. In other words, the decrease in long-term drift also decreases the number of calibrations needed. For a parametric measurement unit in automated test equipment, this outcome is especially pertinent (see [Figure 3](#)).

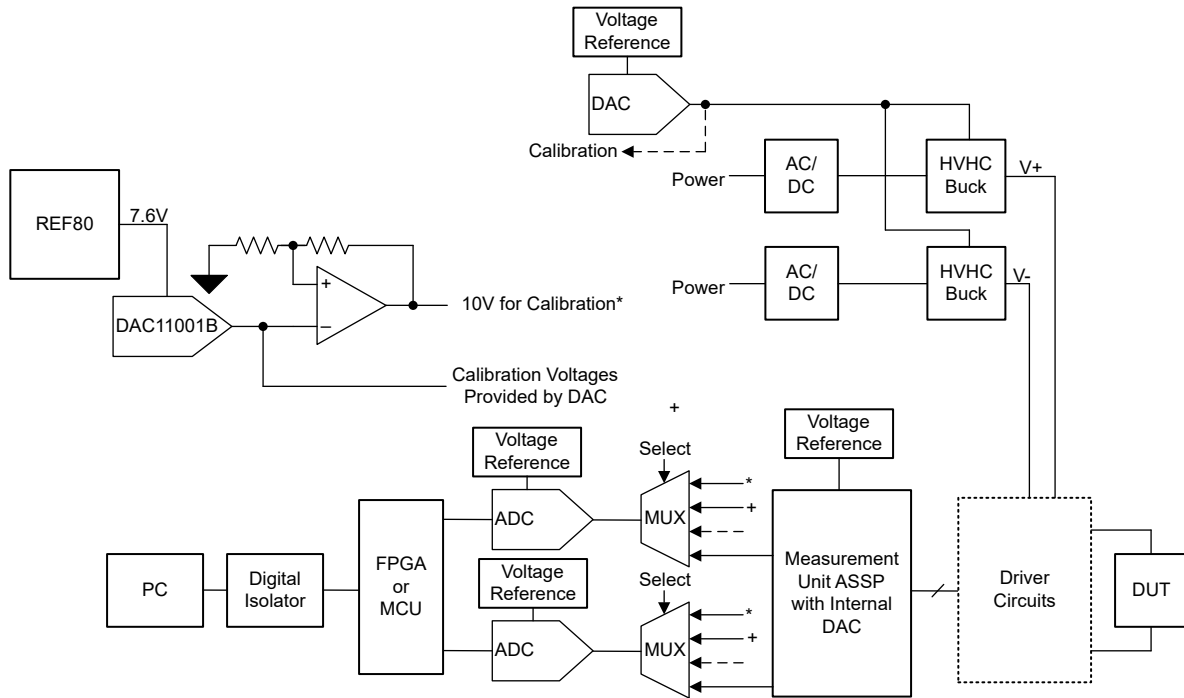

Figure 3. Block diagram of a parametric measurement unit in automated test equipment

Automated test equipment must be calibrated after a certain number of months to ensure that the golden reference output voltage drift has not affected the precision of the tester measurements. Each time calibration occurs, the entire system must go offline, which costs time and money. Using a buried Zener voltage reference such as the REF80 will decrease the time needed for and cost of calibration.

Conclusion

Using the REF80 with advanced calibration methods can allow precise test and measurement applications to maintain accurate for as long as possible. Without precision the likes of what REF80 can produce, test and measurement would fail to provide the necessary results to keep advanced electronics on the path of progression. As we strive to do our best to usher in a new era of precision, devices like the REF80 can lead the way.

Additional resources

- Download the [REF80 evaluation module](#).

Trademarks

All trademarks are the property of their respective owners.

IMPORTANT NOTICE AND DISCLAIMER

TI PROVIDES TECHNICAL AND RELIABILITY DATA (INCLUDING DATA SHEETS), DESIGN RESOURCES (INCLUDING REFERENCE DESIGNS), APPLICATION OR OTHER DESIGN ADVICE, WEB TOOLS, SAFETY INFORMATION, AND OTHER RESOURCES "AS IS" AND WITH ALL FAULTS, AND DISCLAIMS ALL WARRANTIES, EXPRESS AND IMPLIED, INCLUDING WITHOUT LIMITATION ANY IMPLIED WARRANTIES OF MERCHANTABILITY, FITNESS FOR A PARTICULAR PURPOSE OR NON-INFRINGEMENT OF THIRD PARTY INTELLECTUAL PROPERTY RIGHTS.

These resources are intended for skilled developers designing with TI products. You are solely responsible for (1) selecting the appropriate TI products for your application, (2) designing, validating and testing your application, and (3) ensuring your application meets applicable standards, and any other safety, security, regulatory or other requirements.

These resources are subject to change without notice. TI grants you permission to use these resources only for development of an application that uses the TI products described in the resource. Other reproduction and display of these resources is prohibited. No license is granted to any other TI intellectual property right or to any third party intellectual property right. TI disclaims responsibility for, and you will fully indemnify TI and its representatives against, any claims, damages, costs, losses, and liabilities arising out of your use of these resources.

TI's products are provided subject to [TI's Terms of Sale](#) or other applicable terms available either on [ti.com](https://www.ti.com) or provided in conjunction with such TI products. TI's provision of these resources does not expand or otherwise alter TI's applicable warranties or warranty disclaimers for TI products.

TI objects to and rejects any additional or different terms you may have proposed.

Mailing Address: Texas Instruments, Post Office Box 655303, Dallas, Texas 75265
Copyright © 2024, Texas Instruments Incorporated