

# Optimizing system fault detection in real-time control systems with edge AI-enabled MCUs



Michael Wang and Zhen Yu

With current discussions on artificial intelligence (AI) and neural networks mostly focusing on generative applications (generating images, text and videos), it's easy to overlook practical examples where AI will revolutionize electronics in industrial and infrastructure applications.

But even though AI in real-time control systems for [motor drives](#), [solar energy](#) (as shown in [Figure 1](#)) and [battery-management](#) applications won't garner the same number of headlines as a new large language model, the use of edge AI for fault detection can significantly affect system efficiency, safety and productivity.



**Figure 1. Solar panel array**

In this article, I'll discuss how an integrated microcontroller (MCU) can enhance fault detection in high-voltage, real-time control systems. These MCUs use an integrated neural-network processing unit (NPU) to run convolutional neural network (CNN) models to help reduce latency and power usage when monitoring for system faults. Integrating [edge AI](#) capabilities into the same MCU that is managing real-time control can help you optimize system designs while enhancing overall performance.

## Motor bearing and solar arc faults

Reliable operation of motor drive and solar systems requires fast and predictable system fault detection in order to help reduce false alerts, while also monitoring for motor-bearing anomalies and real faults. There are two types of faults that edge AI-enabled MCUs can monitor:

- A motor-bearing fault occurs when there are abnormal conditions or deterioration in the bearings of an electric motor. Detecting these faults is vital to prevent unexpected failures, reduce downtime, and reduce maintenance costs.
- A solar arc fault is an arc discharge that occurs when electricity flows through an unintended path such as air. Solar arc faults are often caused by insulation breakdown, loose connections, or other faults in solar systems. The discharge can generate intense heat, leading to fires or damage to the electrical system. Monitoring and detecting solar arc faults can help prevent dangerous events and ensure the safety and reliability of solar systems.

Without responsive monitoring, a system may experience unplanned downtime or system failure from an actual fault or false alarm, impacting operational efficiency and operator safety. For example, a false alarm in a solar inverter could lead to system downtime and require an inspection, impacting productivity. The missed detection of a live arc could also increase the risk of fire or system damage.

Some motor-bearing fault monitoring methods employ multiple devices in addition to an MCU for real-time control, monitoring through vibration analysis, temperature monitoring and acoustic measurements. This discrete-based approach then uses rules-based detection based on the data to monitor for potential faults, which require manual interpretation and can miss early-stage faults, or fail to detect fault types accurately.

Similarly, the traditional method for arc fault detection is to analyze current signals in the frequency domain and then apply threshold-based rules to detect arc fault signals. But both methods require a lot of system expertise and are limited in their adaptivity and sensitivity, limiting detection accuracy. Also, adding discrete devices to a system for fault monitoring in addition to a dedicated real-time control MCU for motor control can increase system complexity.

Integrated edge-AI based fault detection capabilities that run CNN models locally in a real-time MCU such as the [TMS320F28P550SJ](#) may help improve fault detection rates, helping avoid false alarms while providing better predictive maintenance. With edge AI, these systems can learn and adapt to their environment in order to optimize real-time control, increasing overall system reliability, safety and efficiency while reducing downtime, see [Figure 2](#).

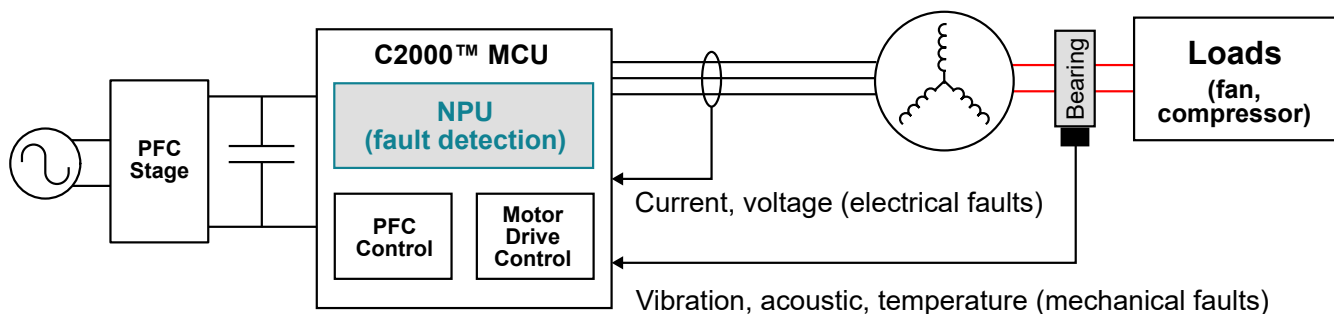

**Figure 2. An edge AI-enabled fault monitoring solution in a real-time control system**

---

## How CNN models enhance fault monitoring and detection in real-time control systems

A CNN model for motor bearing and arc fault detection can learn complex patterns from raw sensor data such as vibration signals, and then detect subtle variations indicative of bearing faults.

CNN models excel in sensor data analysis for fault detection and predictive maintenance because they can autonomously learn from raw or pre-processed sensor data such as motor vibration signals, solar DC currents, or battery voltage and current. The direct extraction of meaningful features without manual intervention enables robust and accurate detection. Meanwhile, sensor data representing variable working conditions and different hardware variations, and different preprocessing algorithms such as Fast Fourier Transform (FFT) can be leveraged to increase the model's adaptability, noise immunity, and reliability, while reducing the total detection or inferencing latency.

Because CNNs can handle large data volumes efficiently and perform well across different operating conditions, they are useful for real-time monitoring and predictive maintenance in industrial settings. Leveraging CNN models in these environments enables earlier and more effective detection of motor bearing faults, improving equipment reliability and operational efficiency.

For motor drives, CNNs can identify fault patterns such as bearing wear or rotor imbalance from vibration or current signals. In solar energy systems, CNNs can detect anomalies in DC current waveforms for arc fault detection. In battery-management applications, CNN models can analyze battery charging profile lifetime, battery health monitoring and battery state-of-charge estimation. Their adaptability ensures accurate fault detection in dynamic conditions, while real-time processing optimizes efficiency.

### Conclusion

In applications such as motor drives and solar systems, real-time fault detection ensures both operational safety and long-term reliability. The ability to accurately identify faults or predict failures in advance significantly enhances system reliability, preventing costly downtime and improving overall performance. Edge AI offers a revolutionary approach, dramatically boosting fault detection precision by processing data locally and in real time, reducing latency and increasing responsiveness.

### Trademarks

All trademarks are the property of their respective owners.

## IMPORTANT NOTICE AND DISCLAIMER

TI PROVIDES TECHNICAL AND RELIABILITY DATA (INCLUDING DATA SHEETS), DESIGN RESOURCES (INCLUDING REFERENCE DESIGNS), APPLICATION OR OTHER DESIGN ADVICE, WEB TOOLS, SAFETY INFORMATION, AND OTHER RESOURCES "AS IS" AND WITH ALL FAULTS, AND DISCLAIMS ALL WARRANTIES, EXPRESS AND IMPLIED, INCLUDING WITHOUT LIMITATION ANY IMPLIED WARRANTIES OF MERCHANTABILITY, FITNESS FOR A PARTICULAR PURPOSE OR NON-INFRINGEMENT OF THIRD PARTY INTELLECTUAL PROPERTY RIGHTS.

These resources are intended for skilled developers designing with TI products. You are solely responsible for (1) selecting the appropriate TI products for your application, (2) designing, validating and testing your application, and (3) ensuring your application meets applicable standards, and any other safety, security, regulatory or other requirements.

These resources are subject to change without notice. TI grants you permission to use these resources only for development of an application that uses the TI products described in the resource. Other reproduction and display of these resources is prohibited. No license is granted to any other TI intellectual property right or to any third party intellectual property right. TI disclaims responsibility for, and you will fully indemnify TI and its representatives against, any claims, damages, costs, losses, and liabilities arising out of your use of these resources.

TI's products are provided subject to [TI's Terms of Sale](#) or other applicable terms available either on [ti.com](https://www.ti.com) or provided in conjunction with such TI products. TI's provision of these resources does not expand or otherwise alter TI's applicable warranties or warranty disclaimers for TI products.

TI objects to and rejects any additional or different terms you may have proposed.

Mailing Address: Texas Instruments, Post Office Box 655303, Dallas, Texas 75265  
Copyright © 2024, Texas Instruments Incorporated