

***CDCM7005 (BGA Package)
Evaluation Module Manual
HPA/High Speed Communications***

User's Guide

IMPORTANT NOTICE

Texas Instruments Incorporated and its subsidiaries (TI) reserve the right to make corrections, modifications, enhancements, improvements, and other changes to its products and services at any time and to discontinue any product or service without notice. Customers should obtain the latest relevant information before placing orders and should verify that such information is current and complete. All products are sold subject to TI's terms and conditions of sale supplied at the time of order acknowledgment.

TI warrants performance of its hardware products to the specifications applicable at the time of sale in accordance with TI's standard warranty. Testing and other quality control techniques are used to the extent TI deems necessary to support this warranty. Except where mandated by government requirements, testing of all parameters of each product is not necessarily performed.

TI assumes no liability for applications assistance or customer product design. Customers are responsible for their products and applications using TI components. To minimize the risks associated with customer products and applications, customers should provide adequate design and operating safeguards.

TI does not warrant or represent that any license, either express or implied, is granted under any TI patent right, copyright, mask work right, or other TI intellectual property right relating to any combination, machine, or process in which TI products or services are used. Information published by TI regarding third-party products or services does not constitute a license from TI to use such products or services or a warranty or endorsement thereof. Use of such information may require a license from a third party under the patents or other intellectual property of the third party, or a license from TI under the patents or other intellectual property of TI.

Reproduction of information in TI data books or data sheets is permissible only if reproduction is without alteration and is accompanied by all associated warranties, conditions, limitations, and notices. Reproduction of this information with alteration is an unfair and deceptive business practice. TI is not responsible or liable for such altered documentation.

Resale of TI products or services with statements different from or beyond the parameters stated by TI for that product or service voids all express and any implied warranties for the associated TI product or service and is an unfair and deceptive business practice. TI is not responsible or liable for any such statements.

Following are URLs where you can obtain information on other Texas Instruments products and application solutions:

Products		Applications	
Amplifiers	amplifier.ti.com	Audio	www.ti.com/audio
Data Converters	dataconverter.ti.com	Automotive	www.ti.com/automotive
DSP	dsp.ti.com	Broadband	www.ti.com/broadband
Interface	interface.ti.com	Digital Control	www.ti.com/digitalcontrol
Logic	logic.ti.com	Military	www.ti.com/military
Power Mgmt	power.ti.com	Optical Networking	www.ti.com/opticalnetwork
Microcontrollers	microcontroller.ti.com	Security	www.ti.com/security
		Telephony	www.ti.com/telephony
		Video & Imaging	www.ti.com/video
		Wireless	www.ti.com/wireless

Mailing Address: Texas Instruments
Post Office Box 655303 Dallas, Texas 75265

EVM IMPORTANT NOTICE

Texas Instruments (TI) provides the enclosed product(s) under the following conditions:

This evaluation kit being sold by TI is intended for use for **ENGINEERING DEVELOPMENT OR EVALUATION PURPOSES ONLY** and is not considered by TI to be fit for commercial use. As such, the goods being provided may not be complete in terms of required design-, marketing-, and/or manufacturing-related protective considerations, including product safety measures typically found in the end product incorporating the goods. As a prototype, this product does not fall within the scope of the European Union directive on electromagnetic compatibility and therefore may not meet the technical requirements of the directive.

Should this evaluation kit not meet the specifications indicated in the EVM User's Guide, the kit may be returned within 30 days from the date of delivery for a full refund. **THE FOREGOING WARRANTY IS THE EXCLUSIVE WARRANTY MADE BY SELLER TO BUYER AND IS IN LIEU OF ALL OTHER WARRANTIES, EXPRESSED, IMPLIED, OR STATUTORY, INCLUDING ANY WARRANTY OF MERCHANTABILITY OR FITNESS FOR ANY PARTICULAR PURPOSE.**

The user assumes all responsibility and liability for proper and safe handling of the goods. Further, the user indemnifies TI from all claims arising from the handling or use of the goods. Please be aware that the products received may not be regulatory compliant or agency certified (FCC, UL, CE, etc.). Due to the open construction of the product, it is the user's responsibility to take any and all appropriate precautions with regard to electrostatic discharge.

EXCEPT TO THE EXTENT OF THE INDEMNITY SET FORTH ABOVE, NEITHER PARTY SHALL BE LIABLE TO THE OTHER FOR ANY INDIRECT, SPECIAL, INCIDENTAL, OR CONSEQUENTIAL DAMAGES.

TI currently deals with a variety of customers for products, and therefore our arrangement with the user **is not exclusive.**

TI assumes **no liability for applications assistance, customer product design, software performance, or infringement of patents or services described herein.**

Please read the EVM User's Guide and, specifically, the EVM Warnings and Restrictions notice in the EVM User's Guide prior to handling the product. This notice contains important safety information about temperatures and voltages. For further safety concerns, please contact the TI application engineer.

Persons handling the product must have electronics training and observe good laboratory practice standards.

No license is granted under any patent right or other intellectual property right of TI covering or relating to any machine, process, or combination in which such TI products or services might be or are used.

Mailing Address:

Texas Instruments
Post Office Box 655303
Dallas, Texas 75265

EVM WARNINGS AND RESTRICTIONS

It is important to operate this EVM within the supply voltage range of 3 V and 3.6 V.

Exceeding the specified input range may cause unexpected operation and/or irreversible damage to the EVM. If there are questions concerning the input range, please contact a TI field representative prior to connecting the input power.

Applying loads outside of the specified output range may result in unintended operation and/or possible permanent damage to the EVM. Please consult the EVM User's Guide prior to connecting any load to the EVM output. If there is uncertainty as to the load specification, please contact a TI field representative.

During normal operation, some circuit components may have case temperatures greater than 45°C. The EVM is designed to operate properly with certain components above 60°C as long as the input and output ranges are maintained. These components include but are not limited to linear regulators, switching transistors, pass transistors, and current sense resistors. These types of devices can be identified using the EVM schematic located in the EVM User's Guide. When placing measurement probes near these devices during operation, please be aware that these devices may be very warm to the touch.

Mailing Address:

Texas Instruments
Post Office Box 655303
Dallas, Texas 75265

Read This First

About This Manual

This manual explains how to use the CDCM7005 evaluation module (EVM) and provides guidelines to build the customer's own systems. The manual includes schematics, layout, bill of materials, and a software description.

How to Use This Manual

This document contains the following chapters:

- Chapter 1—Introduction
- Chapter 2—Quick Start
- Chapter 3—EVM Hardware
- Chapter 4—Serial Peripheral Interface (SPI) Software
- Chapter 5—Schematics, Board Layout, and Parts List

Related Documentation From Texas Instruments

- CDCM7005 Data Sheet, SCASXXX, Texas Instruments

FCC Warning

This equipment is intended for use in a laboratory test environment only. It generates, uses, and can radiate radio frequency energy and has not been tested for compliance with the limits of computing devices pursuant to subpart J of part 15 of FCC rules, which are designed to provide reasonable protection against radio frequency interference. Operation of this equipment in other environments may cause interference with radio communications, in which case the user at his own expense will be required to take whatever measures may be required to correct this interference.

If You Need Assistance. . .

If you need assistance with this device, please email
clocks_apps@list.ti.com

Contents

1	Introduction	1-1
1.1	CDCM7005 Functional Block Diagram	1-2
2	Quick Start	2-1
3	EVM Hardware	3-1
3.1	Board View and Connector Location	3-2
3.2	Hardware Configuration	3-3
3.2.1	Power Supply (P1, P2)	3-3
3.2.2	Onboard Switches and Indicators (SW1–SW2, D1–D4)	3-3
3.2.3	Programming Interfaces (J30, J31)	3-3
3.2.4	Loop Filter (J32–J34)	3-4
3.2.5	High-Speed Outputs and Inputs (J1–J4, J6–J11, J13, J14, J22, and J23)	3-4
3.2.6	VCXO Inputs and Outputs (J16–J18)	3-4
3.2.7	AC-Coupling at PRI_REF (C1, R4, R6) and SEC_REF (C5, R13, R15)	3-5
4	Serial Peripheral Interface (SPI) Software	4-1
4.1	Functional Description	4-2
4.2	Software Installation	4-2
5	Application Level Circuit Diagram	5-1
5.1	Application Circuit Diagram	5-2
5.1.1	Passive Loop Filter	5-2
5.1.2	External Active Loop Filter Using OPA341	5-3
6	Parts List, Board Layouts, and Schematics	6-1
6.1	Parts List	6-2
6.2	Board Layout	6-4
6.3	Schematic	6-9

Figures

3-1	Board View	3-2
4-1	Screen View	4-2
5-1	CDCM7005 With a Passive Loop Filter Configuration	5-2
5-2	CDCM7005 With an External Active Loop Filter Using OPA341	5-3
6-1	Component View and Silkscreen (Top Side)	6-5
6-2	Component View and Silkscreen (Bottom Side)	6-6
6-3	Top Layer View	6-7
6-4	Bottom Layer View	6-8
6-5	Ground Plane View	6-9
6-6	Power Layer View	6-10

Tables

3-1	Connectors, Switches, and Indicators	3-4
3-2	Filter Configurations	3-5

Introduction

The CDCM7005 is a high-performance, low phase noise and low skew clock synchronizer that synchronizes an on-board voltage controlled crystal oscillator (VC(X)O) frequency to an external reference clock. The device operates up to 1.3 GHz. The PLL loop bandwidth and damping factor can be adjusted to meet different system requirements by selecting the external VC(X)O, loop filter components, frequency for PFD, and charge pump current. Each of the five differential LVPECL and five LVCMOS pair outputs can be programmed by a serial peripheral interface (SPI). The SPI allows individual control of the frequency and enable/disable state of each output. As the system requires external components like a loop filter and VC(X)O, this EVM provides an easy method to evaluate and modify the performance and parameters of the clock system in conjunction with the specific customer application. Loop bandwidth can be selected as low as 10 Hz or less, allowing the device to clean the system's clock jitter.

In non PLL mode, the CDCM7005 can be used as a simple LVPECL or LVCMOS buffer with divider options.

Topic	Page
1.1 CDCM7005 Functional Block Diagram	1-2

1.1 CDCM7005 Functional Block Diagram

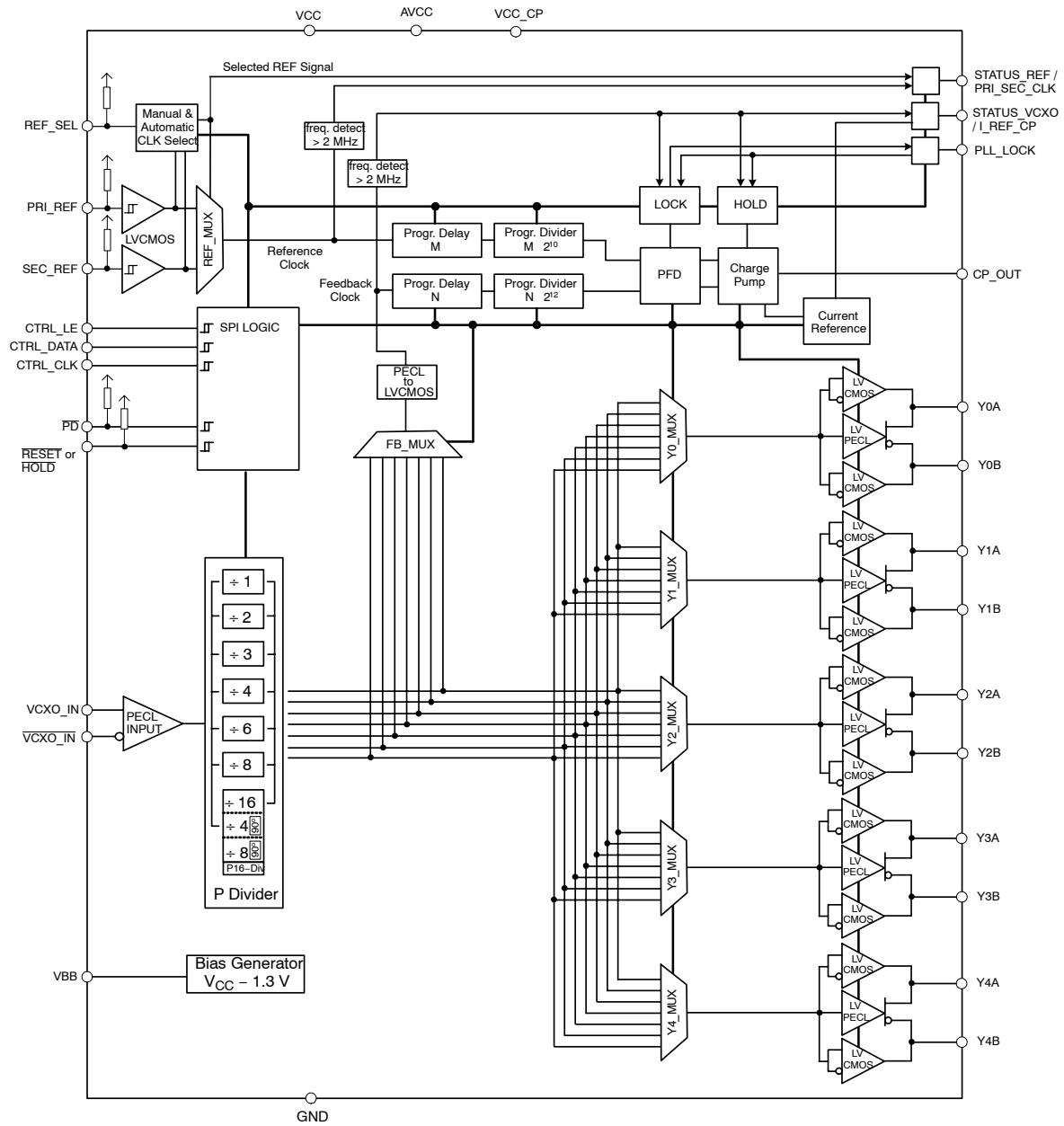

Quick Start

In order to setup the EVM quickly and to take some measurements at default settings, the following actions are required:

- Supply 3.3 V to P1, LED D4 will be on.
- Apply a single-ended reference clock to the reference clock input PRI_REF (pin A1) or SEC_REF (pin B1). For default setting, the reference clock must be 1/8th of the VC(X)O frequency. If REF_SEL is set to 1, then PRI_REF is selected. If REF_SEL is set to 0, then SEC_REF is selected. This selection can be realized via J26 (header 1 and 2 is high; header 2 and 3 is low).
- Connect Y0/Y0B (or Y1/Y1B) to oscilloscope in order to check an output signal. Ensure the oscilloscope has 50 Ω to ground termination.

After power up, D1 is on if there is a valid reference clock and D2 is on if there is a valid VC(X)O clock for the CDCM7005. If D3 turns on, then the reference clock and the VC(X)O clocks are phase locked.

EVM Hardware

This chapter discusses the EVM hardware.

Topic	Page
3.1 Board View and Connector Location	3-2
3.2 Hardware Configuration	3-3

3.1 Board View and Connector Location

Figure 3–1. Board View

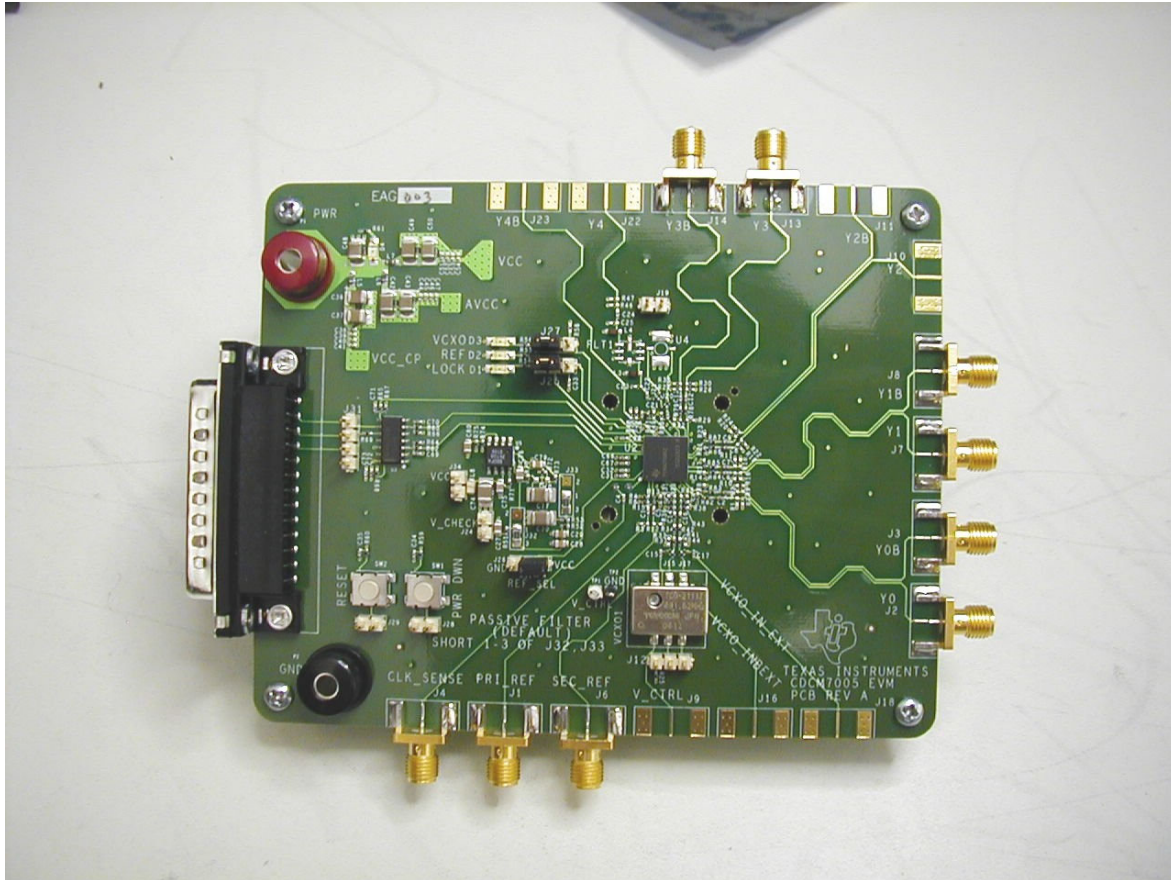

3.2 Hardware Configuration

This section describes the board configuration using on-board jumpers and solder bridges.

3.2.1 Power Supply (P1, P2)

- Supply 3.3 V \pm 10% on P1 and P2 using a stabilized external power supply.
 - **WARNING: Never supply more than 3.6 V on P1.**

3.2.2 Onboard Switches and Indicators (SW1–SW2, D1–D4)

- Push SW1 to enter the power-down mode of the CDCM7005 device. Then all current sources are switched off, all outputs are switched into 3-state, and all dividers (M, N, and P) are reset to default.
- Push SW2 to enter the reset mode of the device. The charge pump (CP) is switched to 3-state and all counters (N, M, P) are reset to zero (the initial divider settings are maintained in SPI).
- The three status outputs of the CDCM7005 are fed to LED indicators. D1 on indicates a valid reference input clock signal. D2 is on if the VC(X)O input clock is valid and D3 turns on if the PLL has been locked.
- D4 indicates power supply

Note:

In case of a low input impedance of the VC(X)O control voltage input, there is a possibility D3 may not turn on to indicate locking.

3.2.3 Programming Interfaces (J30, J31)

The SPI of the device is used for writing to the control register of the device. It consists of three control lines CTRL_CLK, CTRL_DATA, and CTRL_LE. There are four 30-bit wide RAM registers, which can be addressed by the two LSBs of a transferred word. Every transmitted word must have 32 bits, starting with MSB. After supplying power or activating the power-down mode, the registers are loaded with the device default values internally (see the CDCM7005 data sheet, SCAS793). However, if specific register settings are required for any applications, there are two ways to program the device externally:

- Connect the parallel port cable to the PC and EVM parallel port. This needs control S/W (see Chapter 4).

3.2.4 Loop Filter (J32–J34)

The loop filter is one of the key elements determining the loop bandwidth of the PLL. The loop filter converts the charge pump current into the control voltage for the voltage controlled oscillator. The phase difference between the input clocks of the phase frequency detector determines the width of the charge pump output current pulses. These high frequency pulses are transformed into a voltage to control the oscillator.

Basically, three types of loop filters are implemented on the EVM.

- Passive loop filter
- External active loop filter using an external low-noise OPA.

Filter types can be selected by soldering bridges J32–J34, see Table 3–1. Control voltage of the VC(X)O can be measured at J9 or TP1. If an external OPA is used, it needs to be switched on by connecting J34. For example, passive filter operation is provided when pads 1 and 3 of J33 are solder bridged and pads 1 and 3 of J32 are solder bridged.

Default setting: Passive Loop Filter

Table 3–1. Filter Configurations

Bridge	Passive Filter	Active With An External OPA
J33	1–3	1–2
J34	Open	Closed
J32	1–3	1–2

3.2.5 High-Speed Outputs and Inputs (J1–J4, J6–J11, J13, J14, J22, and J23)

The CDCM7005 drives five differential LVPECL outputs. All PECL outputs are ac-coupled and terminated with 150 Ω to GND. This is in contrast to typical LVPECL termination, which requires $V_{CC} - 2$ V as termination voltage. The reason is to simplify the power supply scheme. The device output's trace impedance is 50 Ω and traces are matched in length. All outputs have options for pullup and pulldown resistors.

When the CDCM7005 is powered up, it defaults to five LVPECL outputs. However, this EVM is configured as follows:

- Y0 – Y2 = LVPECL
- Y3, Y4 = LVCMOS (in addition Y4 has an option for a custom filter)

The reference input clock signal has to be applied to J1 or J6. The reference input clock signal can be sensed on J4. In this case, close the bridge J5 (the oscilloscope's 50 Ω may be used to terminate the 50- Ω trace). The reference input clock sense line is matched to the LVPECL outputs line to avoid any additional delay offset. The input is ac-coupled (C4).

3.2.6 VC(X)O Inputs and Outputs (J16–J18)

The CDCM7005 requires an external VC(X)O in order to complete the PLL loop. The VC(X)O adjusts the frequency and phase depending on the control voltage level coming from the loop filter and provide the input clock to the LVPECL block.

Another option would be to use an external source via J16 and J18.

3.2.7 AC-Coupling at PRI_REF (C1, R4, R6) and SEC_REF (C5, R13, R15)

An ac-coupling is provided at PRI_REF and SEC_REF to ease the use of the CDCM7005 with different signaling levels (LVCMOS, LVPECL, LVDS,...). However, the ac-coupling will increase the PLL stabilization time after power up due to transient effects. It also increases the switching time between PRI_REF and SEC_REF in case of automatic reference clock switching. Therefore, the ac-coupling must be removed for optimized system performance (C1 and C5 has to be replaced with an 0- Ω resistor and R4, R6, R13, and R15 have to be removed).

Serial Peripheral Interface (SPI) Software

This chapter discusses the serial peripheral interface software.

Topic	Page
4.1 Functional Description	4-2
4.2 Software Installation	4-2

4.1 Functional Description

Programming software here as described is intended for programming the internal control register of the CDCM7005. The software runs under Windows98, NT, 2000, and XP. A quick installation is required prior to use. See the *Software Installation* section.

There are several cases where programming is mandatory.

As a rule of thumb here are some examples:

- Use of active loop filter
- Change of divider ratio or disable of certain LVPECL/LVCMOS outputs
- Select between LVPECL or LVCMOS output
- Change of phase offset, (Delay M/N), or selection of 90° or 180° phase shift
- Change of charge pump output current.
- Widening the lock detect window

Figure 4–1. Screen View

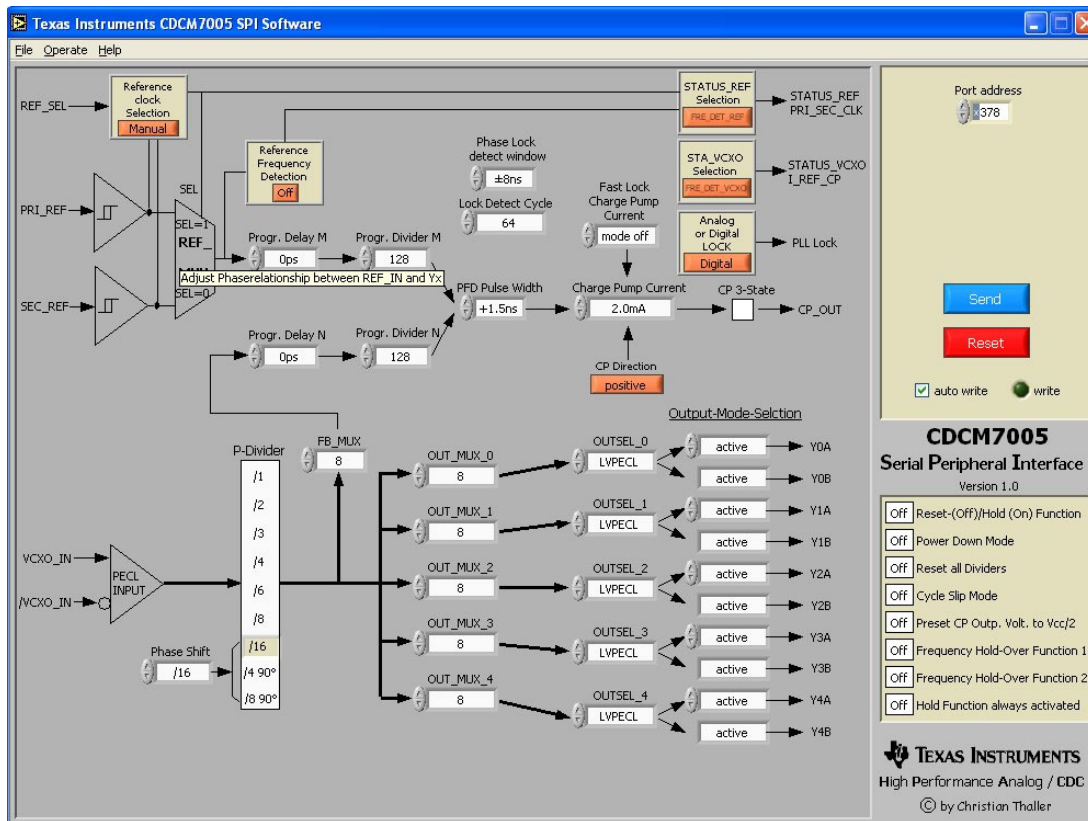

4.2 Software Installation

Follow the steps below in order to install the SPI control software:

- 1) Run program setup.exe in the Installer folder
- 2) Reboot your computer
- 3) Run the Software from Start -> Programs -> CDCM7005_EVM -> CDCM7005_EVM

Application Circuit Diagram

This chapter discusses the application circuit diagram.

Topic	Page
5.1 Application Circuit Diagram	5-2

5.1 Application Circuit Diagram

The following applications sections the two loop filter configurations are discussed.

5.1.1 Passive Loop Filter

The passive loop filter is a second order filter (two poles, one zero). The zero is required for the overall loop stability. R1, C1, and C2 generate the dominant pole of the system. A second pole is introduced by R2 and C3.

Figure 5–1. CDCM7005 With a Passive Loop Filter Configuration

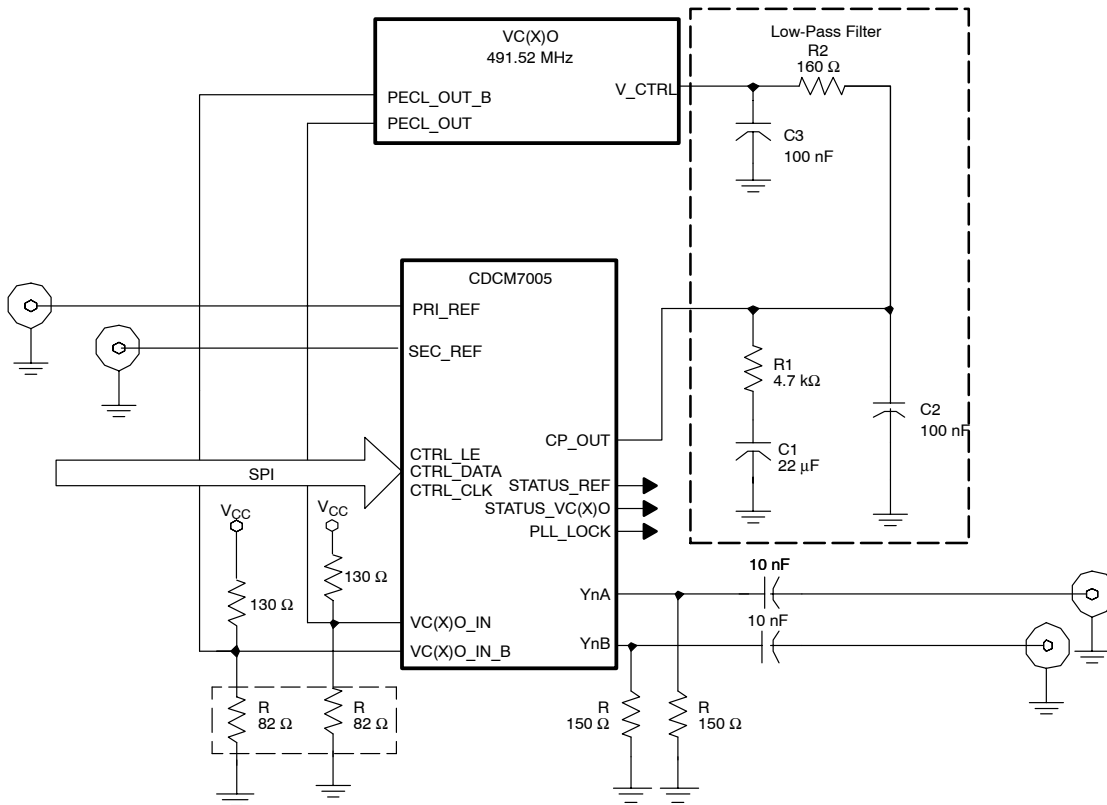

5.1.2 External Active Loop Filter Using OPA341

Figure 5-2. CDCM7005 With a External Active Loop Filter Using OPA341

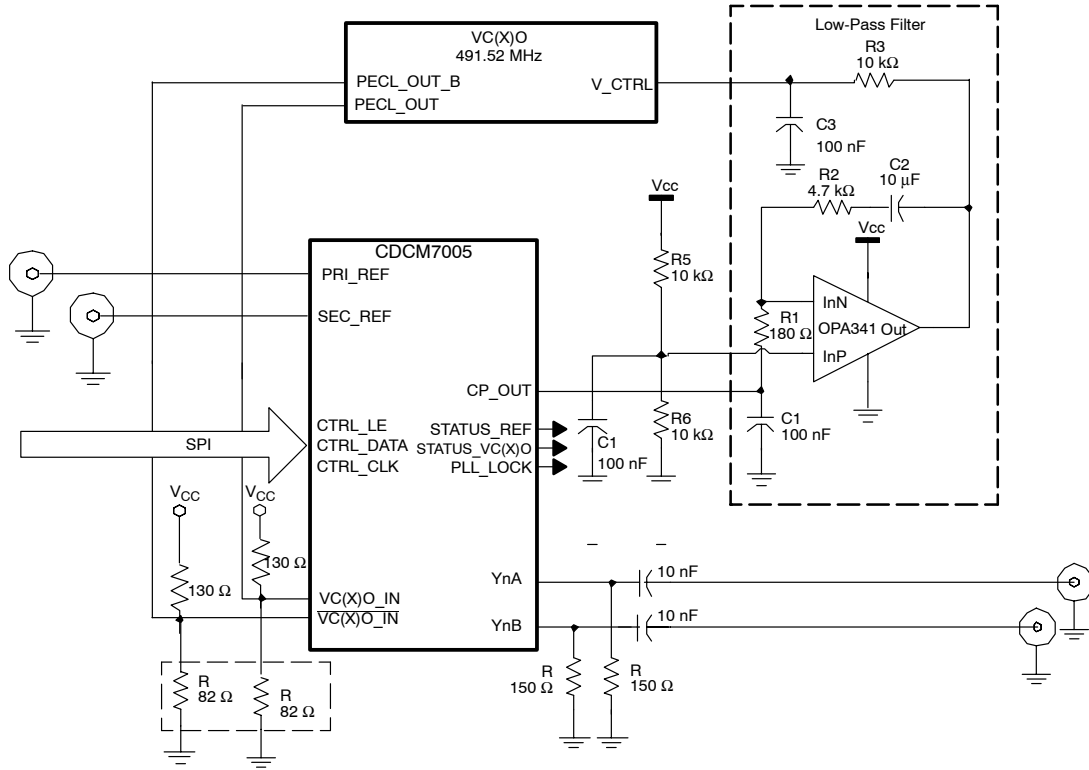

Parts List, Board Layout, and Schematic

This chapter contains the parts list, board layout, and schematic for the CDCM7005 EVM.

Topic	Page
6.1 Parts List	6-2
6.2 Board Layout	6-4
6.3 Schematic	6-8

6.1 Parts List

Item	QTY	Reference Designator	Footprint	Part	Part Number
1	24	C1-C9, C12, C13, C15, C17, C26, C40, C41, C46, C47, C53, C54, C56-C58, C66	smd_cap_0402	10 nF	Panasonic ECJ-0EB1E103K
2	2	C72, C10	smd_cap_0402	100 nF	Panasonic ECJ-0EB1E104K
3	7	C11, C32, C62-C64, C68, C73	smd_cap_0402	100 pF	Panasonic ECJ-0EB1E101K
4	2	C14, C16	smd_cap_0402	0 Ω	Panasonic ERJ-2GE0R00X
5	1	C18	smd_cap_0402	1000 pF	Panasonic ECJ-0EB1E102K
6	1	C19	smd_cap_0603	1 μ F	Panasonic ECJ-1VF1C105Z
7	2	C20, C22	smd_cap_0402	0.1 μ F	Panasonic ECJ-0EB1A104K
8	1	C21	smd_cap_0402	10 nF	Panasonic ECJ-0EB1E103K
9	1	C23	smd_cap_0402	NU 1.1 pF	NU Rohm MCH155A1R1CK
10	1	C24	smd_cap_0402	22 pF	Panasonic ECJ-0EC1H220J
11	1	C25	smd_cap_0402	NU 1 pF	NU Rohm MCH155A1R1CK
12	7	C27-C29, C75, C76, C79, C80	smd_cap_0805	0.1 μ F	Panasonic ECP-U1C104MA5
13	1	C30	smd_cap_1210	22 μ F	Murata GRM32ER71A226KE20L
14	1	C31	smd_cap_0402	22 nF	Panasonic ECJ-0EB1E104K
15	3	C33-C35	smd_cap_0402	10 nF	Panasonic ECJ-0EF1H103Z
16	4	C36, C42, C48, C49	smd_cap_1210_pol	22 μ F	Panasonic ECS-T1CC226R
		C49	smd_cap_1210_pol	22 μ F	Panasonic ECS-T1CC226R
17	5	C37, C43, C50, C55, C65	smd_cap_1210_pol	10 μ F	Panasonic ECS-H1CC106R
18	3	C38, C44, C51	smd_cap_0402	100 nF	Yageo 04022F104Z7B20D
19	3	C39, C45, C52	smd_cap_0402	33 nF	AVX 0402YD333KAT2A
20	4	C59-C61, C67	smd_cap_0402	2.2 nF	AVX 0402YC223KAT2A
21	3	C69-C71	smd_cap_0402	10 pF	Panasonic ECD-G0E100C

Item	QTY	Reference Designator	Footprint	Part	Part Number
22	2	C74	smd_cap_1210	10 μ F	Murata GRM32DR61E106KA12L
		C77	smd_cap_1210	10 μ F	Murata GRM32DR61E106KA12L
23	1	C78	smd_cap_0805	NU	Panasonic ECP-U1C104MA5
24	3	D1-D3	smd_led_1206	Amber	Lite-On LTST-C150AKT
25	1	D4	smd_led_1206	GREEN	Lite-On LTST-C150KGKT
26	1	FLT1	ts-38s	TS-38S	Toyocom Filter
27	7	J1-J4, J6-J8	sma_alt	SMA	Johnson Comp 142-0701-841
28	1	J5	jumper2	HEADER 2	
29	9	J9-J11, J13, J14, J16, J18, J22, J23	sma_alt	NU_SMA	Johnson Comp 142-0701-841
30	4	J12, J25, J26, J27	hdr3_100ctr	HDR3	Header 3 pos, 0.1 ctr
31	2	J17, J15	smd_bridge_0402	SMD3P_BRIDGE	Panasonic ERJ-2GE0R00X
32	1	J19	jumper2	HDR2	Header 2 pos, 0.1 ctr
33	2	J21, J20	smd_bridge_0402	SMD3P_BRIDGE	Panasonic ERJ-2GE0R00X
34	3	J24, J28, J29	jumper2	HDR2	Header 2 pos, 0.1 ctr
35	1	J30	dcon25m	PARALLEL PORT	SPC Technology DB-25P-PCB
36	1	J31	jumper4	HDR4	Header 4 pos, 0.1 ctr
37	2	J33, J32	JUMPER3_SMD_WVIA_CD C7005	HDR 3_cdc7005	Use 0 W to short pins (see assy dwg)
38	1	J34	jumper2	HDR2	Header 3 pos, 0.1 ctr
39	1	L1	smd_cap_0603	75 Ω at 100 MHz	Murata BLM18BA750SN1D
40	1	L2	smd_cap_0603	470 nH	Murata LQW18ANR47J00D
41	2	L4, L3	smd_cap_0603	180 nH	Panasonic ELJ-FJR18JF2
42	3	L5-L7	smd_cap_0603	75 Ω at 100 MHz	Murata BLM18BA750SN1D
43	1	L8	smd_cap_0805	2.2 nH	J W Miller Magnetics PM0805-2N2M
44	1	P1	banana_jack	PWR_IN	SPC Technologies 845R
45	1	P2	banana_jack	GND	SPC Technologies 845B
46	18	R1, R2, R7, R9, R10, R11, R16, R18-R20, R22, R24, R26, R27, R30, R35, R48, R50	smd_res_0402	NU 100 Ω	Panasonic ERJ-2RKF1000X
47	2	R3, R12	smd_res_0402	NU	Panasonic ERJ-2GEJ510X

Parts List

Item	QTY	Reference Designator	Footprint	Part	Part Number
48	7	R4, R6, R13, R15, R62, R63, R65	smd_res_0402	100 Ω	Panasonic ERJ-2RKF1000X
49	6	R5, R8, R14, R17, R21, R23	smd_res_0402	150 Ω	Panasonic ERJ-2RKF1500X
50	10	R25, R57, R59, R60, R68-R71, R74, R75	smd_res_0402	10 k Ω	Panasonic ERJ-2RKF1002X
51	2	R28, R45	smd_res_0402	NU 0 Ω	Panasonic ERJ-2GE0R00X
52	4	R29, R32, R49, R80	smd_res_0402	NU 150 Ω	Panasonic ERJ-2RKF1500X
53	2	R38, R31	smd_res_0402	130 Ω	Panasonic ERJ-2GEJ131X
54	10	R33, R34, R41, R42, R82, -R87	smd_res_0402	0 Ω	Panasonic ERJ-2GE0R00X
55	2	R43, R36	smd_res_0402	82 Ω	Panasonic ERJ-2GEJ820X
56	2	R37, R44	smd_res_0402	NU	NU
57	2	R39, R40	smd_res_0402	62 W	Panasonic ERJ-2GEJ620X
58	2	R47, R46	smd_res_0402	NU 100	Panasonic ERJ-2RKF1000X
59	4	R51, R64, R66, R67	smd_res_0402	100 k Ω	Panasonic ERJ-2RKF1003X
60	1	R52	smd_res_0402	160 Ω	Panasonic ERJ-2RKF1002X
61	2	R53, R72	smd_res_0402	4.7 k Ω	Panasonic ERJ-2RKF1472X
62	3	R54-R56	smd_res_0402	750	Panasonic ERJ-2GEJ131X
63	1	R58	smd_res_0402	NU 12K 1%	Panasonic ERJ-2RKF4121X
64	1	R61	smd_cap_0402	1.5 k Ω	Panasonic ERJ-2RKF1501X
65	1	R73	smd_res_0402	180 Ω	Panasonic ERJ-2RKF1472X
66	3	R78, R79, R81	smd_res_0402	22 Ω	Panasonic ERJ-2GEJ220X
67	2	SW2, SW1	switch_reset	SW PUSHBUTTON	KT11P3JM
68	2	TP1, TP2	testpin_30dia	T POINT R	Test point
69	1	U2	mbga_pt8mm_64_skt	CDCM7005	Texas Instruments CDCM7005
70	1	U3	soic14	SN74LV125	Texas Instruments SN74LV125AD
71	1	U4	soic_round_4	NU SGA-4586	NU Sirenza SGA-4586
72	1	U5	soic8	OPA341	Texas Instruments OPA341UA
73	1	VCXO1	VCXO_6	VCXO_6	Toyocom VCXO
74	4	MP3	STAND OFF		Legs for PCB
75	4	MP2	SCREW		Legs for PCB

6.2 Board Layout

Figure 6–1. Component View and Silkscreen (Top View)

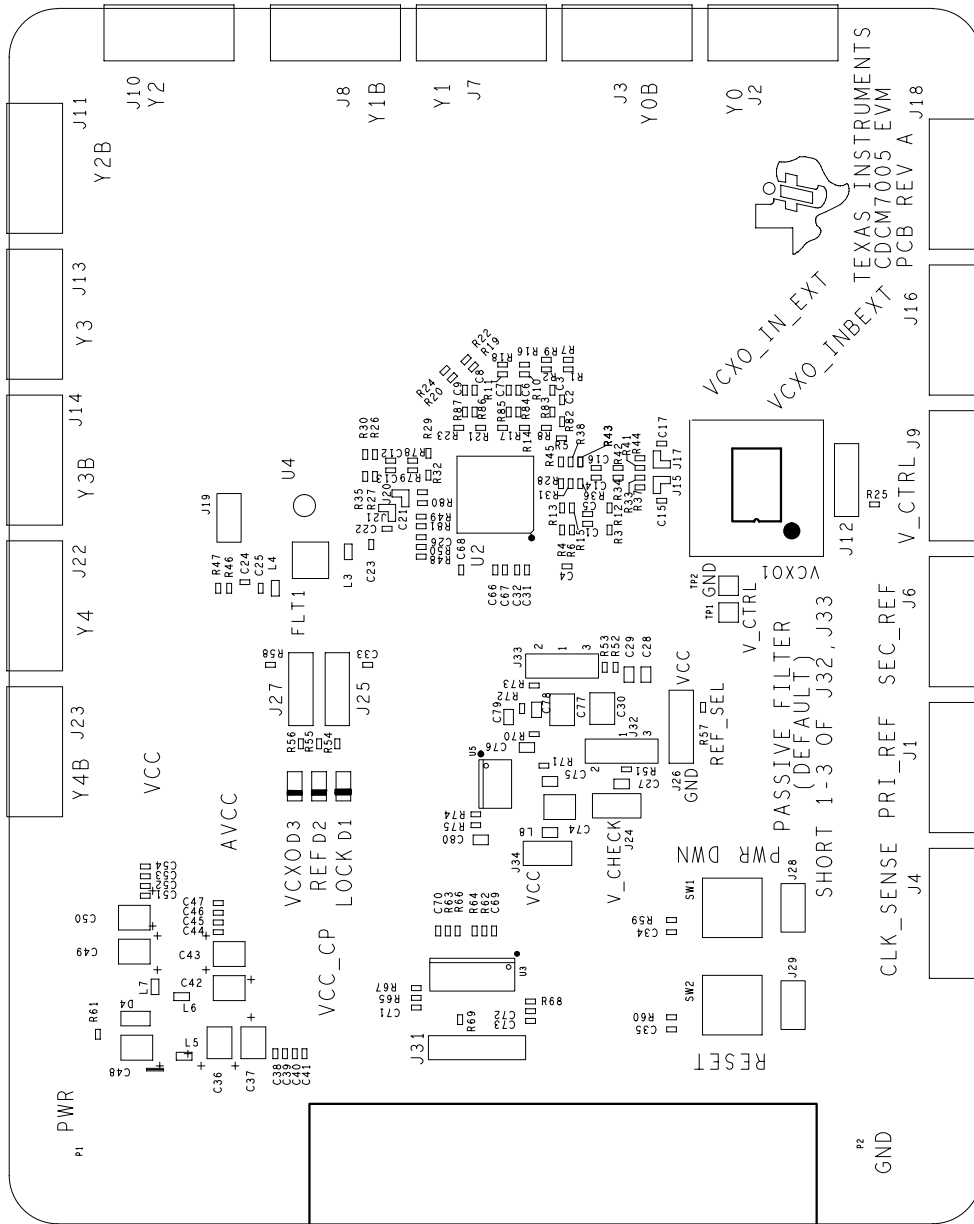

TEXAS INSTRUMENTS
CDCM7005 EVM
PCB REV A
SILKSCREEN TOP
SHEET 7 OF 11

Figure 6-2. Component View and Silkscreen (Bottom View)

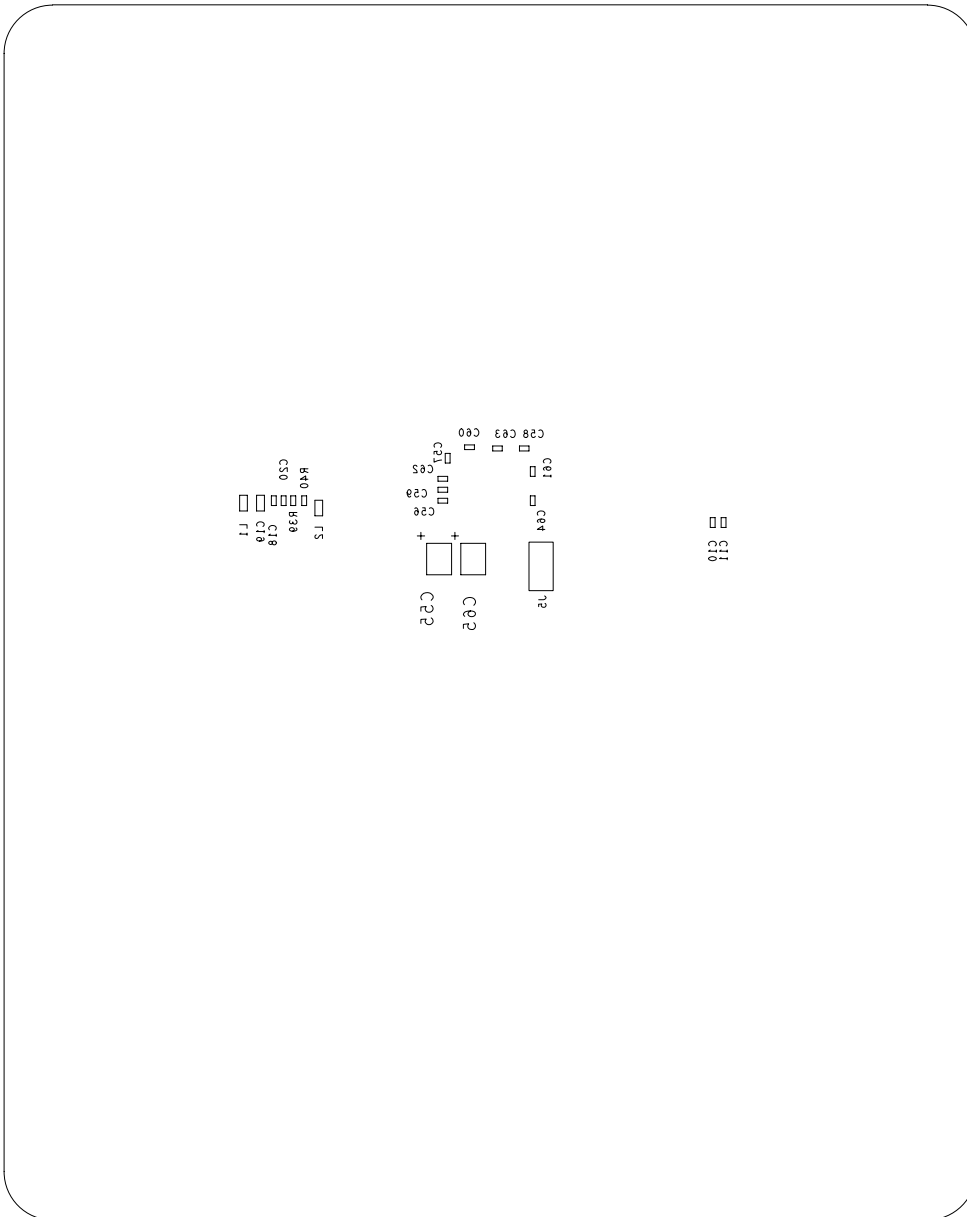

TEXAS INSTRUMENTS
 CDCM7005 EVM
 PCB REV. A
 SILKSCREEN BOTTOM
 SHEET 8 OF 11

Figure 6-3. Top Layer View

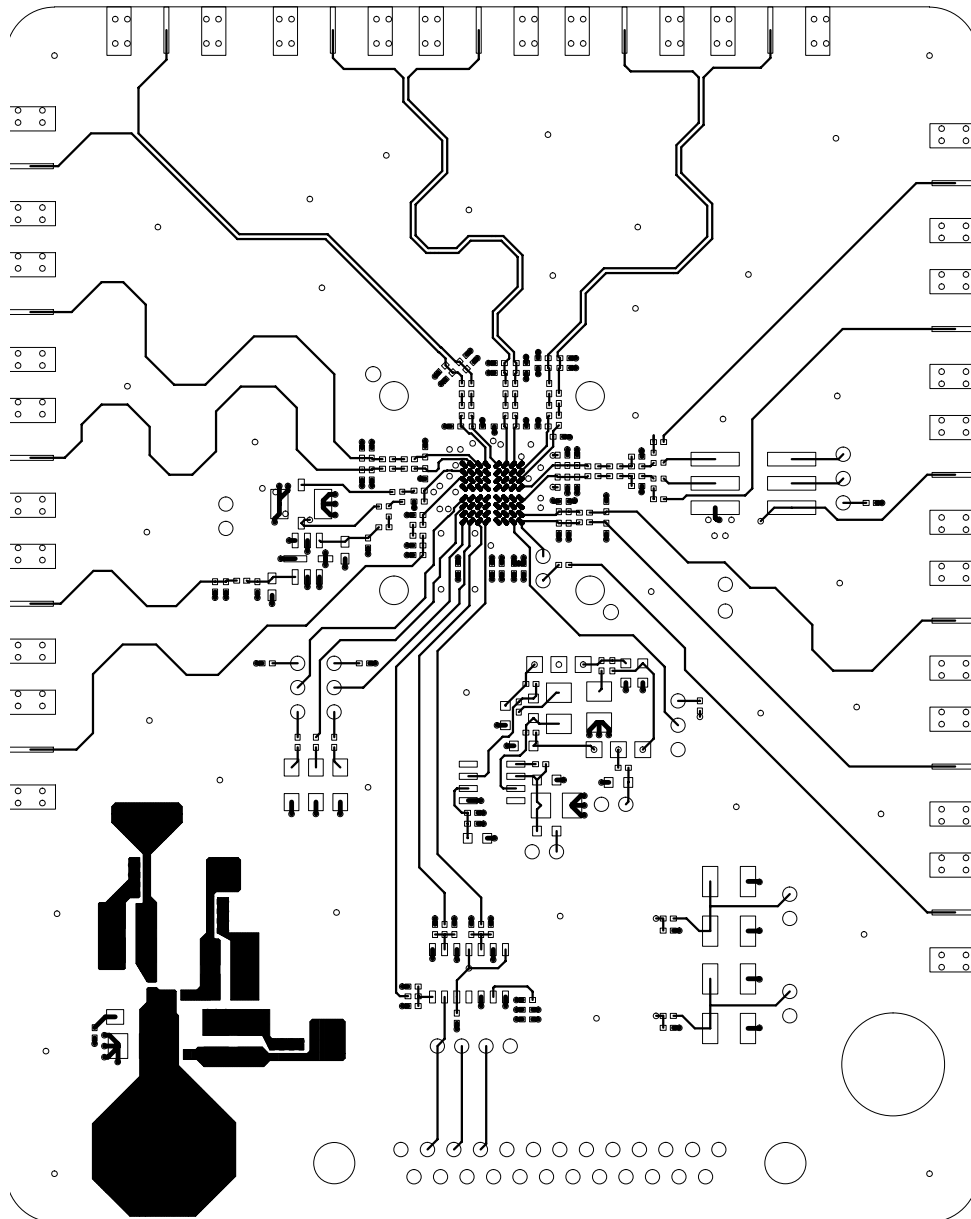

TEXAS INSTRUMENTS
DCM7005_EVM
PCB REV A
TOP SIDE - LAYER 1
SHEET 1

Figure 6-4. Bottom Layer View

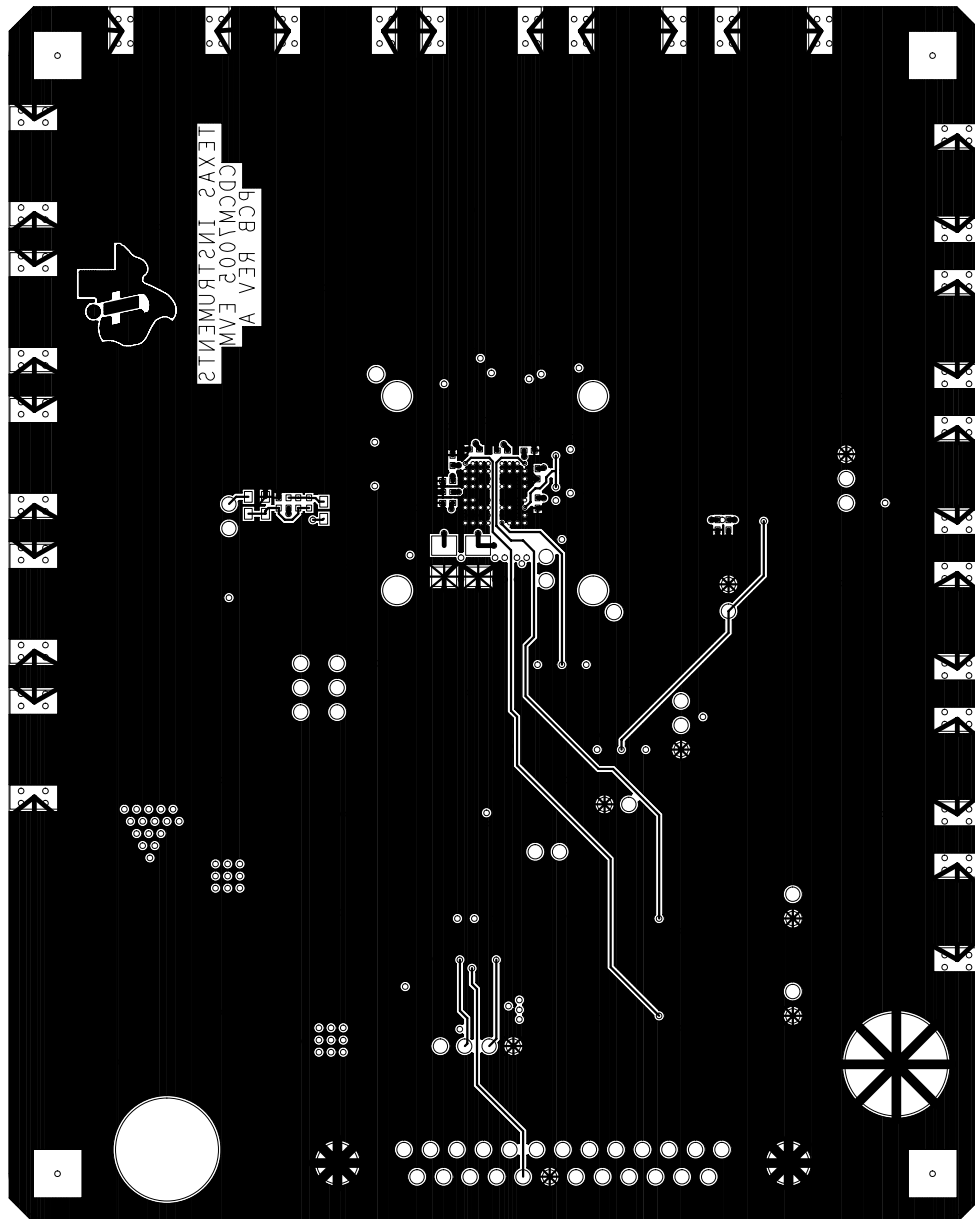

TEXAS INSTRUMENTS
CDCM1003 EVM
PCB REV A
BOTTOM SIDE - LAYER 4
SHEET 4 OF 11

Figure 6-5. Ground Plane View

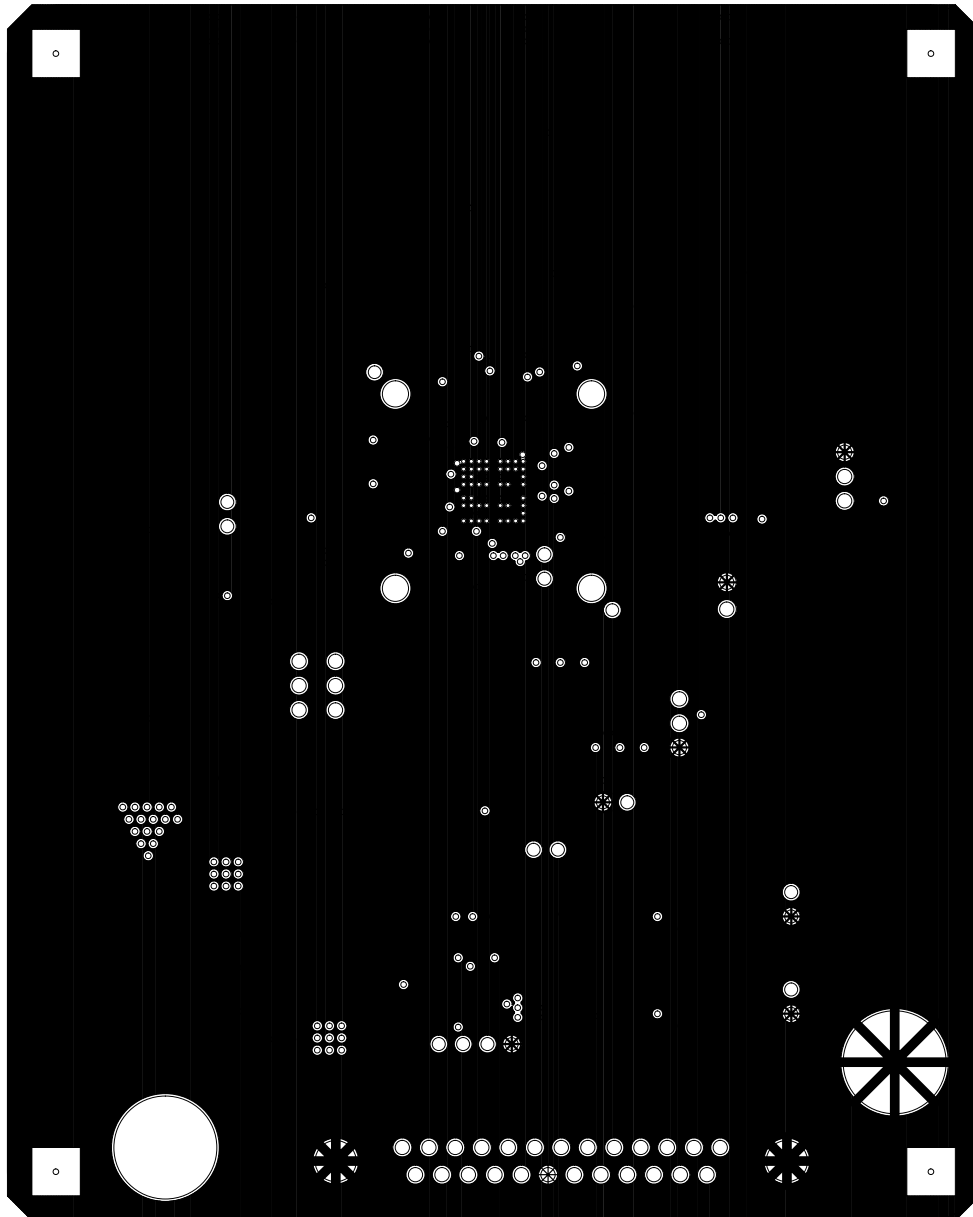

TEXAS INSTRUMENTS
CDCM7005 EVM
PCB REV A
GROUND PLANE_1 LAYER 2
SHEET 2 OF 11

Figure 6–6. Power Layer View

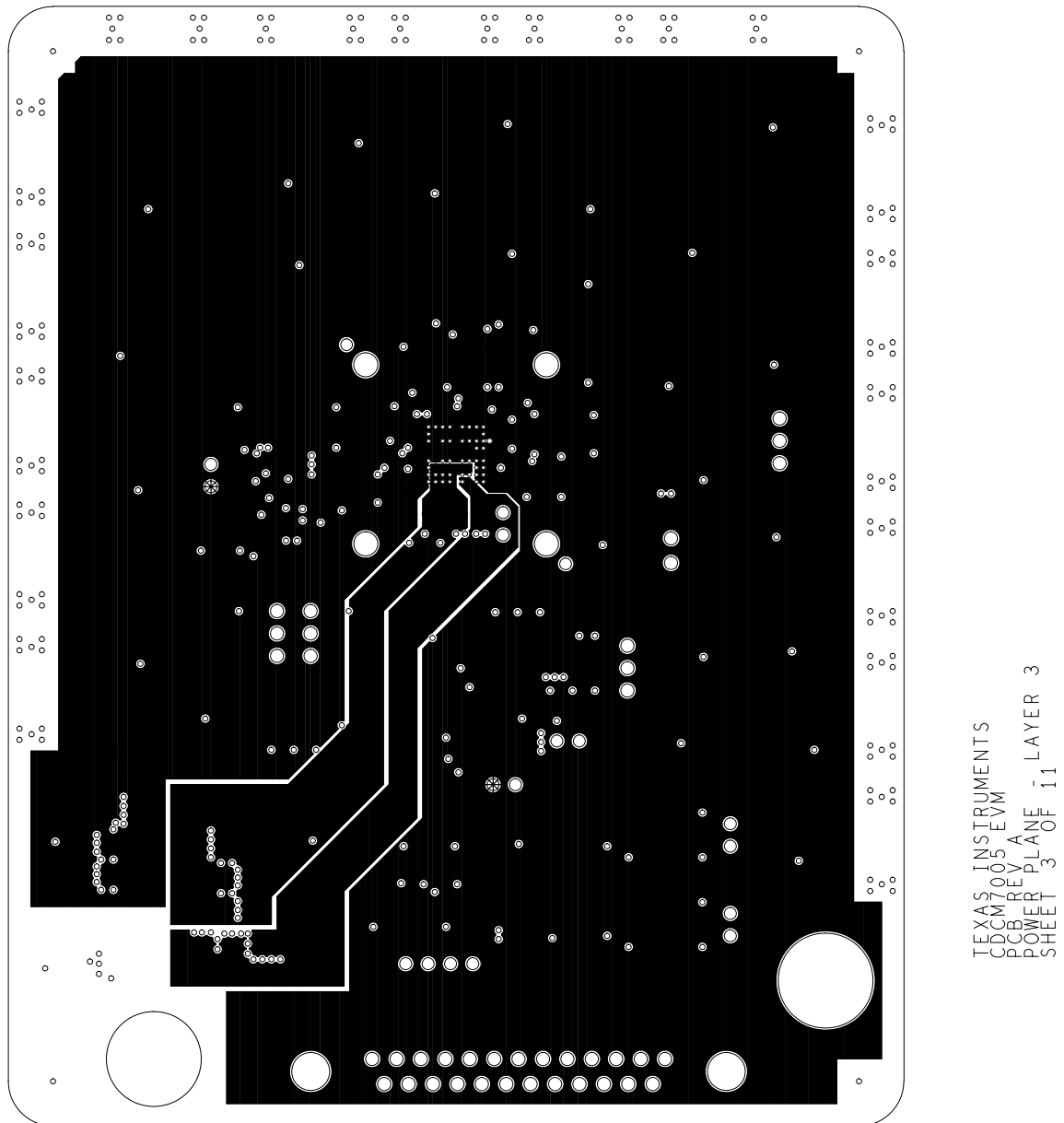

6.3 Schematic

The following page contains the schematic for the CDCM7005.

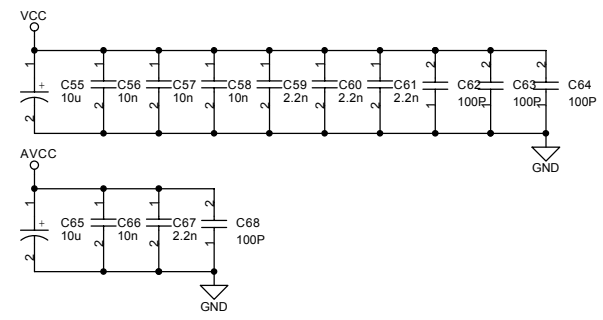
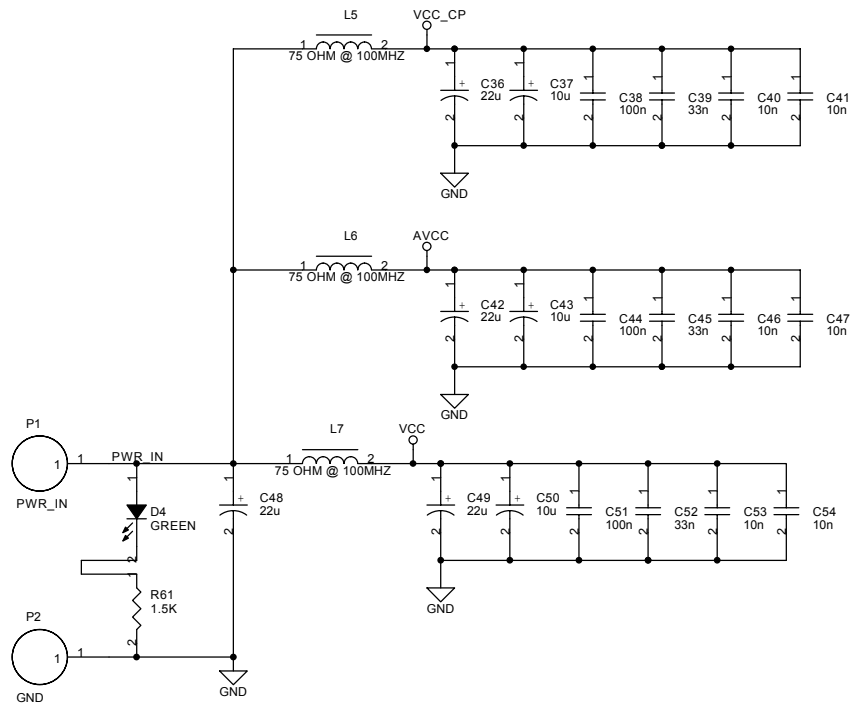

TEXAS INSTRUMENTS

Title: **CDCM7005_BGA Evaluation Module**

Size B	Document Number	Rev A
	CDCM7005EVM_BGA-SCH	

Date: Thursday, January 06, 2005 Sheet 4 of 5

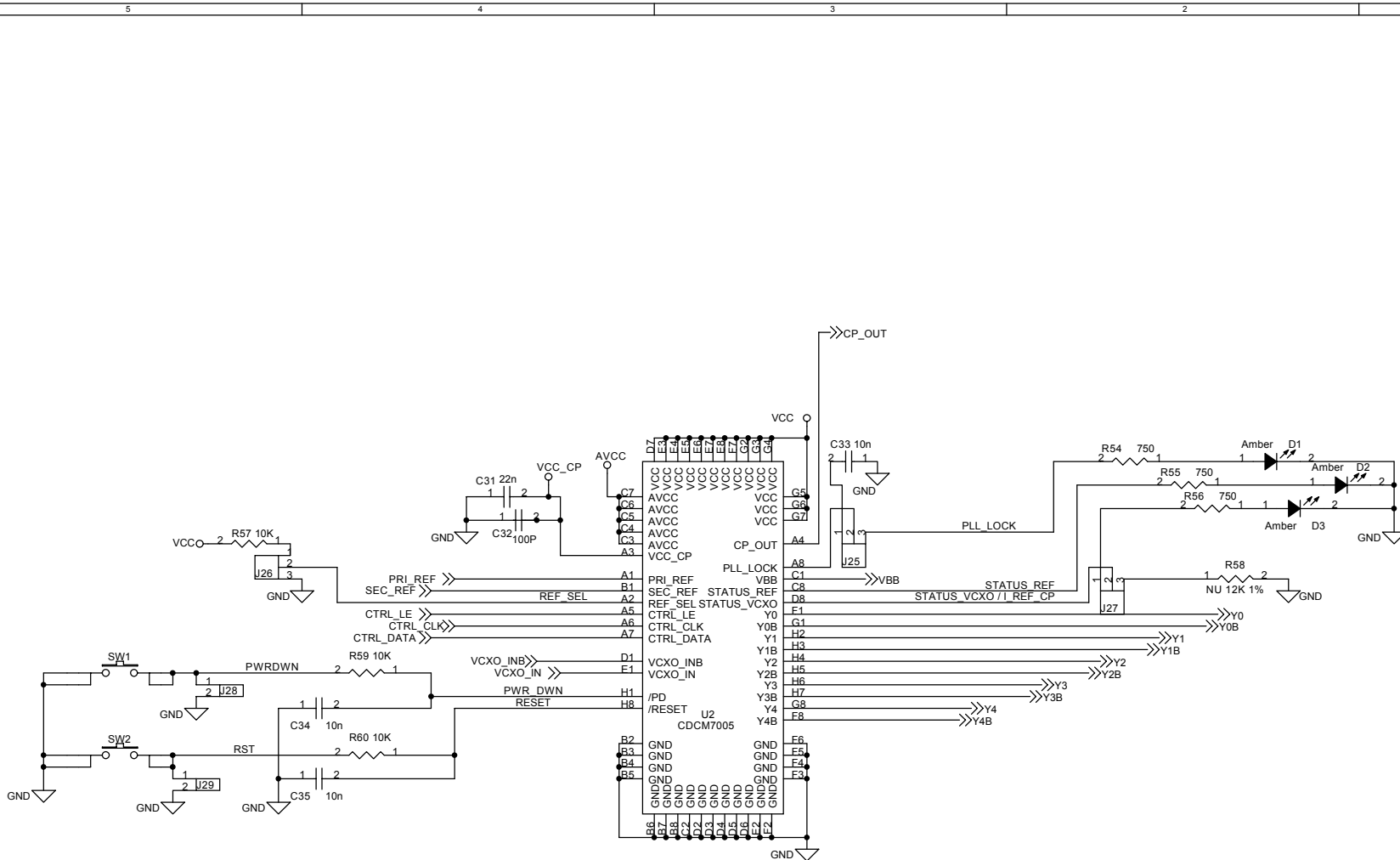

TEXAS INSTRUMENTS

Title: **CDCM7005_BGA Evaluation Module**

Size B Document Number **CDCM7005EVM_BGA-SCH** Rev A

Date: Thursday, January 06, 2005 Sheet 3 of 5

Passive Filter (Default Setting): short pin 1 & 3 on J32, J33
Active Filter w/ External Op Amp: short pin 1 & 2 on J32, J33, J34

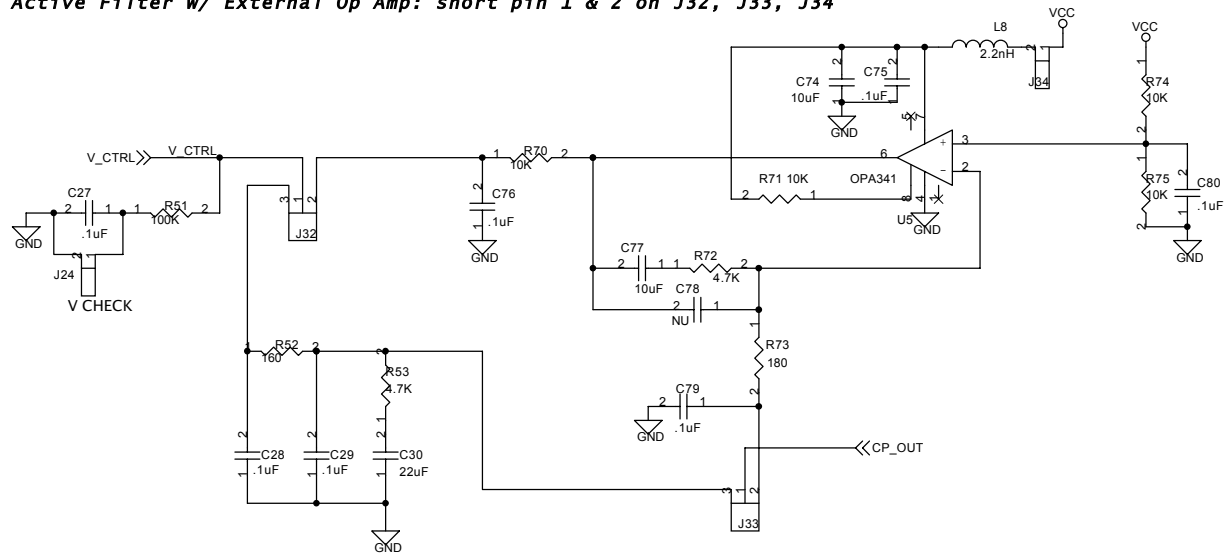

Title		
CDCM7005_BGA Evaluation Module		
Size	Document Number	Rev
B	CDCM7005EVM_BGA-SCH	A
Date:	Thursday, January 06, 2005	Sheet 1 of 5

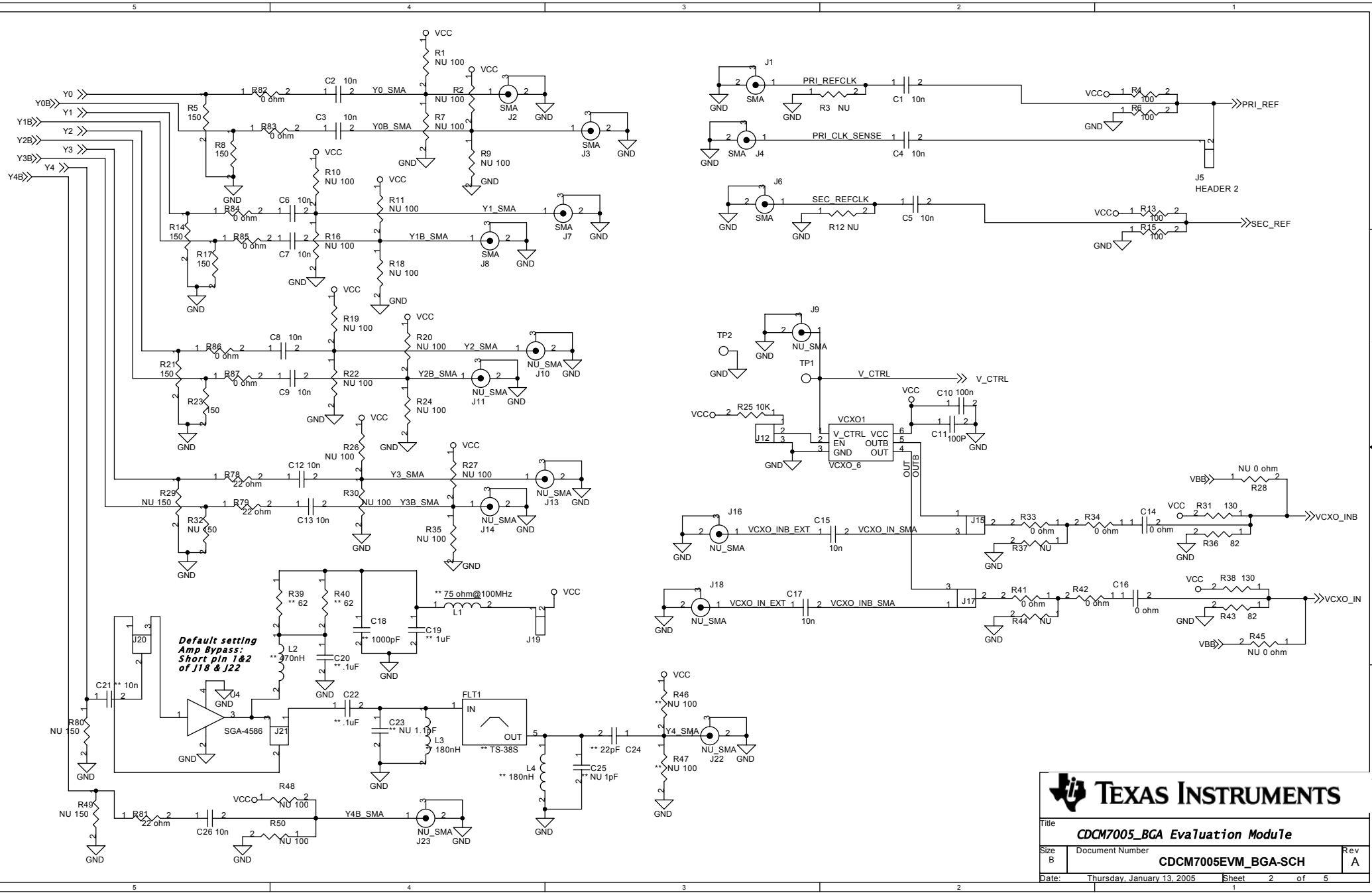

**Default setting
Amp Bypass:
Short pin 1&2
of J18 & J22**

TEXAS INSTRUMENTS

Title CDCM7005_BGA Evaluation Module		
Size B	Document Number CDCM7005EVM_BGA-SCH	Rev A
Date: Thursday, January 13, 2005	Sheet 2	of 5

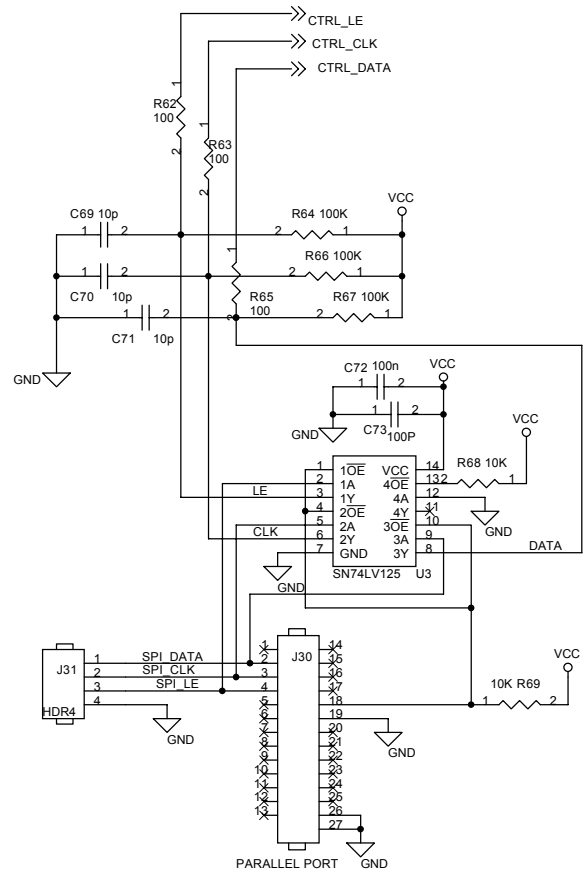

TEXAS INSTRUMENTS

Title: **CDCM7005_BGA Evaluation Module**

Size B	Document Number	Rev A
	CDCM7005EVM_BGA-SCH	

Date: Thursday, January 06, 2005 Sheet 5 of 5