

EVM User's Guide: BQ25308EVM

BQ25308 Evaluation Module



Description

The BQ25308 is a highly-integrated standalone switch-mode battery charger for 1-cell Li-ion and Li-polymer, and LiFePO₄ batteries. The BQ25308 supports 4.1V to 17V input voltage and 3A fast charge current. The integrated current sensing topology of the device enables high charge efficiency and low BOM cost. The best-in-class 200nA low quiescent current of the device conserves battery energy and maximizes the shelf time for portable devices. The BQ25308 is available in a 3x3 WQFN package for easy 2-layer layout and space limited applications.

Features

- Standalone charger and easy to configure
- High-efficiency, 1.2MHz, synchronous switchmode buck charger
 - 92.5% charge efficiency at 2A from 5V input for 1-cell battery
 - 91.8% charge efficiency at 2A from 9V input for 1-cell battery
- Single input to support USB input and high voltage adapters
 - Support 4.1V - 17V input voltage range with 28V absolute maximum input voltage rating
 - Input Voltage Dynamic Power Management (VINDPM) tracking battery voltage

- 3.6V / 4.05V / 4.15V / 4.2V charge voltage
- 3.0A maximum fast charge current
- 200nA low battery leakage current at 4.5V VBAT
- 4.25µA VBUS supply current in IC disable mode
- Charge accuracy
 - ±0.5% charge voltage regulation
 - ±10% charge current regulation
- Safety
 - Disable charge for dead battery condition
 - Thermal regulation and thermal shutdown
 - Input Under-Voltage Lockout (UVLO) and OverVoltage Protection (OVP)
 - Battery overcharge protection
 - Safety timer for precharge and fast charge
 - Charge disabled if current setting pin ICHG is open or short
 - Cold/hot battery temperature protection
 - Fault report on STAT pin

Applications

- [Wireless speaker](#)
- [Barcode scanner](#)
- [Gaming](#)
- [Cradle charger](#)
- [Cordless power tool](#)
- [Building automation](#)
- [Medical](#)

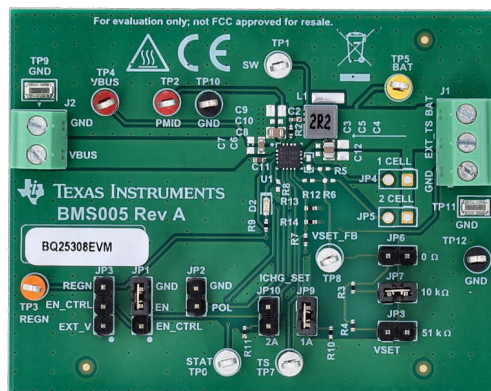

BQ25308EVM Hardware Board

1 Evaluation Module Overview

1.1 Introduction

The BQ25308EVM is an evaluation kit for the BQ25308 integrated battery charge management IC.

This user's guide provides detailed testing instructions for the BQ25308 evaluation module (EVM). Also included are descriptions of the necessary equipment, equipment setup, procedures, the printed-circuit board layouts, schematics, and the bill of materials (BOM).

Throughout this user's guide, the abbreviations *EVM*, *BMS005*, and the term *evaluation module* are synonymous with the BQ25308 evaluation module, unless otherwise noted.

1.2 Kit Contents

Item	Quantity
BQ25308EVM	1

1.3 Specification

PARAMETER	CONDITIONS	MIN	TYP	MAX	UNIT
V _{BUS}		4.1		17	V
V _{BAT}				4.2	V
TS				5	V
I _{V_{BUS}}				3	A
I _{sw}				3	A

1.4 Device Information

For detailed features and operation, refer to [Table 1-1](#) for the device and data sheet.

Table 1-1. Device Data Sheet

Device	Data Sheet	EVM Label	Variant
BQ25308	SLUSFD7	BQ25308EVM	009

The BMS005 evaluation module (EVM) is a complete charger module for evaluating an integrated, standalone, synchronous buck battery charger using the device listed above.

2 Hardware

2.1 I/O Descriptions

Table 2-1 lists the input and output connections available on this EVM and the respective descriptions.

Table 2-1. EVM I/O Connections

Jack	Description
J1(1) – GND	Ground.
J1(2) – EXT_TS	Connect to thermistor of external battery.
J1(3) – BATTERY	Positive rail of the charger battery input, connected to the positive terminal of the external battery.
J2(1) – GND	Ground.
J2(2) – VIN	Positive rail of the charger input voltage.

Table 2-2 lists the jumper and shunt installations available on this EVM and the respective descriptions.

Table 2-2. EVM Jumper and Shunt Installation

Jack	Description	BQ2530X Setting
SH-JP1	EN pull-up rail selection. 1-2 pulls EN up to external VDD (EN_CTRL either REGN or external voltage source depending on JP3 configuration). 2-3 pulls EN down to GND.	JP1 2-3 Installed
SH-JP2	POL pull-up rail selection. 1-2 POL pull down to GND.	Shunt not installed
SH-JP3	EN external VDD rail selection (EN_CTRL). 1-2 pulls EN_CTRL to external voltage supply connected to JP3-1. 2-3 pulls EN_CTRL to REGN.	Shunt not installed
SH-JP4	Not used for BQ25308.	Jumper not installed
SH-JP5	Not used for BQ25308.	Jumper not installed
SH-JP6	VSET Short to GND. For charge regulation voltage corresponding to this setting, refer to data sheet of the respective battery charger IC shown in Table 1-1.	Installed
SH-JP7	VSET Resistor pull down to GND of 10.2kΩ. For charge regulation voltage corresponding to this setting, refer to data sheet of the respective battery charger IC shown in Table 1-1.	Shunt not installed
SH-JP8	VSET Resistor pull down to GND of 51.1kΩ. For charge regulation voltage corresponding to this setting, refer to data sheet of the respective battery charger IC shown in Table 1-1.	Shunt not installed
SH-JP9	ICHG Resistor pull down to GND with 40.2kΩ to set charge current to 1A.	Installed
SH-JP10	ICHG Resistor pull down to GND with 20kΩ to set charge current to 2A.	Shunt not installed

For recommended operating conditions, refer to data sheet of the respective battery charger IC shown in Table 1-1.

2.2 Equipment

This section includes a list of supplies required to perform tests on this EVM.

1. **Power Supply #1 (PS1):** A power supply capable of supplying 5V at 3A is required. While this part can handle larger voltage and current, a larger voltage and current is not necessary for this procedure.
Power Supply #2 (PS2): A power supply capable of supplying 5V at 1A is required.
2. **Loads:** Load #1 (4-Quadrant Supply, Constant Voltage < 4.5V): A *Kepeco* Load, BOP, 20-5M, DC 0 to ±20 V, 0 to ±5 A (or higher).
Alternative Option: A 0–20 V/0–5 A, > 30-W DC electronic load set in a constant voltage loading mode.
3. **Meters:** (4x) *Fluke 75* multimeters (equivalent or better).
4. No software is required to test this part.

2.3 Equipment Setup

1. Review EVM connections in [Table 2-1](#).
2. Set PS1 for 5V DC, 2A current limit and then turn off the supply.
3. Set PS2 for 3V DC, 2A current limit and then turn off the supply.
4. Connect the output of PS1 to J2 (VBUS and PGND) as shown in [Figure 2-1](#).
5. Connect a voltage meter across TP4 (VBUS) and TP9 (PGND), or across J2.
6. Turn on Load #1 as shown in [Figure 2-1](#), set to constant voltage mode, and output to 2.5V. Disable Load.
7. Connect one voltage meter across TP5 (BAT) and TP11 (PGND) or across J1-3 and J1-1 as shown in [Figure 2-1](#).
8. Connect one voltage meter across TP2 (PMID) and TP10 (PGND).
9. Connect the output of PS2 to TP7 (TS) and TP12 (PGND) as shown in [Figure 2-1](#).
10. Install shunts as shown in [Table 2-2](#).

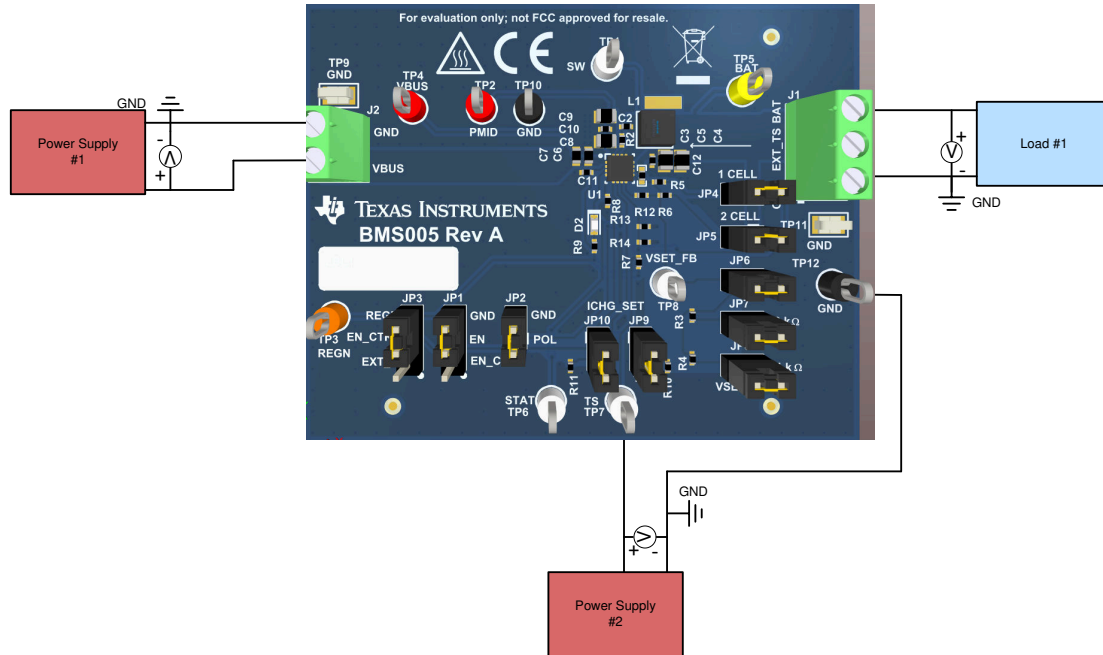

Figure 2-1. Original Test Setup for BMS005

3 Implementation Results

3.1 Test Setup and Results

3.1.1 Test Procedure

3.1.1.1 Initial Settings

Use the following steps to enable the BQ25308 EVM test setup:

1. Make sure [Section 2.3](#) steps have been followed.
2. Turn on PS1.
 - Measure → VPMID (PMID-TP2 and PGND-TP10) = 5.00V ± 0.3V.
 - Completely disconnect PS1 from J2 if different voltage value is seen on PMID.

Note

Completely disconnect Load #1 from BATTERY connections if different value is seen.

3.1.1.2 Precharge Mode Verification

1. Turn on PS2
2. Enable Load #1 and take measurements as follows:
 - a. **Measure** → VBAT (BAT-TP5 and PGND-TP11) = 2.5V ± 0.1V
 - b. **Observe** → STAT LED (D2) on
 - c. **Measure** → IBAT for respective battery charger IC from [Table 3-1](#).

Table 3-1. Precharge Current Measurement

	BQ2530XEVM
IBAT	100mA ± 50mA

3.1.1.3 Fast Charge Mode Verification

1. Change Load #1 to 3.7V and take measurements as follows:
 - a. **Measure** → VBAT (BAT-TP5 and PGND-TP11) = 3.7V ± 0.1V
 - b. **Observe** → STAT LED (D2) on
 - c. **Measure** → IBAT for respective battery charger IC from [Table 3-2](#)

Table 3-2. Fast Charge Current Measurement

	BQ2530XEVM
IBAT	1000mA ± 100mA

3.1.1.4 Battery Temperature Monitoring Verification

1. Turn on PS2 and take measurements as follows:
 - a. **Measure** → VTS (TS-TP7 and PGND-TP12) = 3V ± 0.1V
 - b. **Observe** → STAT LED (D2) on
 - c. **Measure** → IBAT for respective battery charger IC from [Table 3-2](#).
2. Change PS2 to 4.5V and take measurements as follows:
 - a. **Measure** → VTS (TS-TP7 and PGND-TP12) = 4.5V ± 0.1V
 - b. **Observe** → STAT LED (D2) blinking at 1Hz to indicate a fault
 - c. **Measure** → IBAT = 0A ± 10mA
 - d. Battery charger is operating in COLD

For more information on TS threshold, refer to data sheet of respective battery charger IC in [Table 1-1](#).

3. Change PS2 to 0V and take measurements as follows:
 - a. **Measure** → VTS (TS-TP7 and PGND-TP12) = 0V ± 0.1V
 - b. **Observe** → STAT LED (D2) blinking at 1Hz to indicate a fault
 - c. **Measure** → IBAT = 0A ± 10mA
 - d. Battery charger is operating in HOT

For more information on TS threshold, refer to data sheet of respective battery charger IC in [Table 1-1](#).

3.1.1.5 Helpful Tips

1. BQ25308EVM is configured by default to operate with TS in normal range. If external thermistor is available, connect external thermistor at J1(2)-EXT_TS and J1(1)-PGND, and remove R14.
2. The leads and cables to the various power supplies, batteries and loads have resistance. The current meters also have series resistance. The charger dynamically reduces charge current depending on the voltage sensed at the VBUS pin (using the VINDPM feature), BAT pin (as part of normal termination), and TS pin (through the battery temperature monitoring feature via battery thermistor). Therefore, voltmeters must be used to measure the voltage as close to the IC pins as possible instead of relying on the digital readouts of the power supply.
3. When using a source meter that can source and sink current as your battery simulator, TI highly recommends adding a large (1000+ μ F) capacitor at the EVM BATTERY and GND connectors to simulate a real battery. Configuring the source meter for 4-wire sensing eliminates the need for a separate voltmeter to measure the voltage at the BAT pin.

When using 4-wire sensing, always make sure that the sensing leads are connected to prevent accidental overvoltage by the power leads.

4 Hardware Design Files

4.1 Schematic

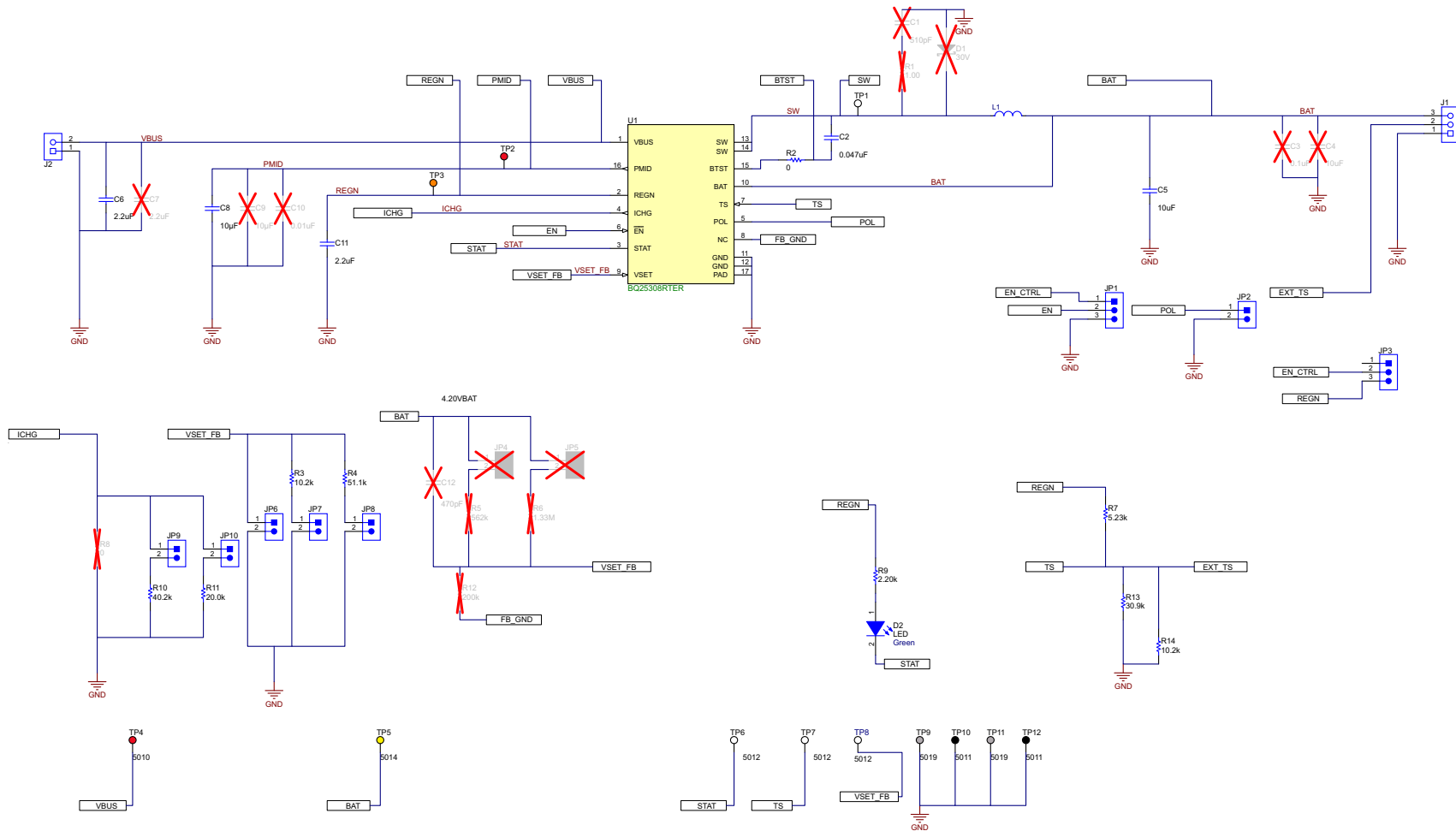

Figure 4-1. Schematic

4.2 PCB Layout

Minimize the switching node rise and fall times for minimum switching loss. Proper layout of the components minimizing high-frequency current path loop is important to prevent electrical and magnetic field radiation and high-frequency resonant problems. This PCB layout priority list must be followed in the order presented for proper layout:

1. Place the input capacitor as close as possible to the PMID pin and GND pin connections and use the shortest copper trace connection or GND plane.
2. Place the inductor input terminal as close to the SW pin as possible. Minimize the copper area of this trace to lower electrical and magnetic field radiation but make the trace wide enough to carry the charging current. Do not use multiple layers in parallel for this connection. Minimize parasitic capacitance from this area to any other trace or plane.
3. Put an output capacitor near to the inductor and the IC. Tie ground connections to the IC ground with a short copper trace connection or GND plane.
4. Place decoupling capacitors next to the IC pins and make the trace connection as short as possible.
5. A critical point is that the exposed power pad on the backside of the IC package must be soldered to the PCB ground. Make sure that there are sufficient thermal vias directly under the IC connecting to the ground plane on the other layers.
6. The via size and number must be enough for a given current path.
7. For more layout guidelines and recommendations refer to the data sheet of the respective battery charger IC.
8. See the EVM design for the recommended component placement with trace and via locations. For the QFN information, refer to [Quad Flatpack No-Lead Logic Packages Application Report](#) and [QFN and SON PCB Attachment Application Report](#).

4.2.1 Board Layout

The board layout is shown in [Figure 4-2](#) to [Figure 4-7](#).

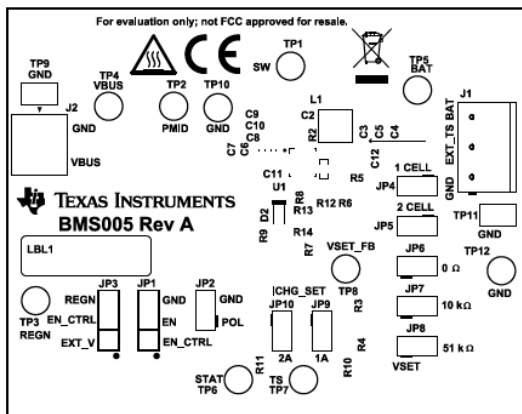

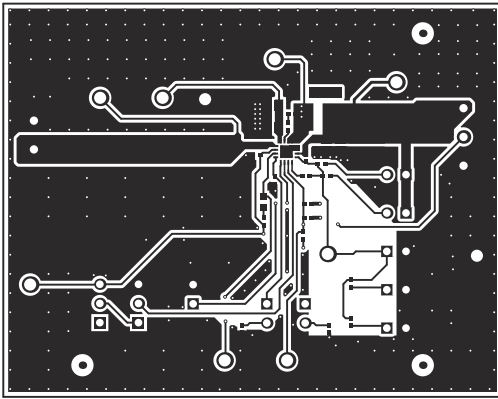

Figure 4-4. Top Layer

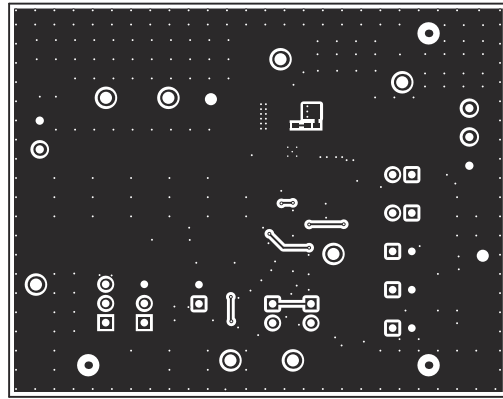

Figure 4-5. Bottom Layer

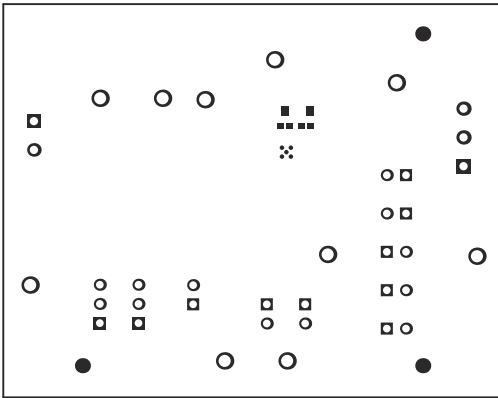

Figure 4-6. Bottom Solder

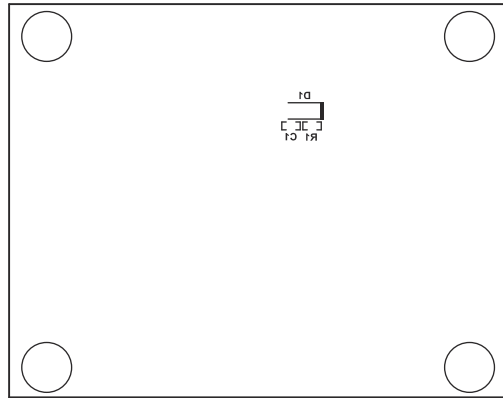

Figure 4-7. Bottom Overlay

4.3 Bill of Materials

Table 4-1 lists the BQ25308EVM BOM.

Table 4-1. BQ25308EVM Bill of Materials

Designator	Quantity	Value	Description	Package Reference	PartNumber	Manufacturer	Alternate Part Number ⁽¹⁾	Alternate Manufacturer ⁽¹⁾
!PCB1	1		Printed Circuit Board		BMS005	Any		
C2	1	0.047 μ F	CAP, CERM, 0.047 μ F, 25V, \pm 10%, X7R, 0402	0402	GRM155R71E473KA88D	MuRata		
C5	1	10 μ F	CAP, CERM, 10 μ F, 16V, \pm 20%, X7R, 0805	0805	EMK212BB7106MG-T	Taiyo Yuden		
C6	1	2.2 μ F	CAP, CERM, 2.2 μ F, 35V, \pm 10%, X5R, 0603	0603	GRM188R6YA225KA12D	MuRata		
C8	1	10 μ F	CAP, CERM, 10 μ F, 25V, \pm 10%, X5R, 0805	0805	CC0805KKX5R8BB106	Yageo		
C11	1	2.2 μ F	CAP, CERM, 2.2 μ F, 16V, \pm 10%, X5R, 0402	0402	GRM155R61C225KE11D	MuRata		
D2	1	Green	LED, Green, SMD	1.6x0.8x0.8mm	LTST-C190GKT	Lite-On		
H1, H2, H3, H4	4		Bump, Hemisphere, 0.25 X 0.075, Clear	75x250 mil	SJ5382	3M		
J1	1		Terminal Block Receptacle, 3x1, 3.81mm, R/A, TH	Term Block, 3 pos	1727023	Phoenix Contact		
J2	1		Conn Term Block, 2POS, 3.81mm, TH	2POS Terminal Block	1727010	Phoenix Contact		
JP1, JP3	2		Header, 100mil, 3x1, Tin, TH	Header, 3 PIN, 100mil, Tin	PEC03SAAN	Sullins Connector Solutions		
JP2, JP6, JP7, JP8, JP9, JP10	6		Header, 100mil, 2x1, Tin, TH	Header, 2 PIN, 100mil, Tin	PEC02SAAN	Sullins Connector Solutions		
L1	1	1 μ H	SMD power inductor, 14.6m Ω DCR	SMD2, 4mm x 4mm	MAPM0420LA1R0M-LF	Microgate		
LBL1	1		Thermal Transfer Printable Labels, 0.650" W x 0.200" H - 10,000 per roll	PCB Label 0.650 x 0.200 inch	THT-14-423-10	Brady		
R2	1	0	RES, 0, 5%, 0.063 W, 0402	0402	RC0402JR-070RL	Yageo America		
R3, R14	2	10.2k	RES, 10.2 k, 1%, 0.063 W, AEC-Q200 Grade 0, 0402	0402	CRCW040210K2FKE D	Vishay-Dale		
R4	1	51.1k	RES, 51.1 k, 1%, 0.063 W, AEC-Q200 Grade 0, 0402	0402	CRCW040251K1FKE D	Vishay-Dale		
R7	1	5.23k	RES, 5.23 k, 1%, 0.063 W, AEC-Q200 Grade 0, 0402	0402	CRCW04025K23FKE D	Vishay-Dale		
R9	1	2.20k	RES, 2.20 k, 1%, 0.063 W, AEC-Q200 Grade 0, 0402	0402	CRCW04022K20FKE D	Vishay-Dale		

Table 4-1. BQ25308EVM Bill of Materials (continued)

Designator	Quantity	Value	Description	Package Reference	PartNumber	Manufacturer	Alternate Part Number ⁽¹⁾	Alternate Manufacturer ⁽¹⁾
R10	1	40.2k	RES, 40.2 k, 1%, 0.063 W, AEC-Q200 Grade 0, 0402	0402	CRCW040240K2FKE D	Vishay-Dale		
R11	1	20.0k	RES, 20.0 k, 1%, 0.063 W, AEC-Q200 Grade 0, 0402	0402	CRCW040220K0FKE D	Vishay-Dale		
R13	1	30.9k	RES, 30.9 k, 1%, 0.063 W, AEC-Q200 Grade 0, 0402	0402	CRCW040230K9FKE D	Vishay-Dale		
SH-JP1, SH-JP6, SH-JP9	3	1x2	Shunt, 100mil, Gold plated, Black	Shunt	SNT-100-BK-G	Samtec	969102-0000-DA	3M
TP1, TP6, TP7, TP8	4		Test Point, Multipurpose, White, TH	White Multipurpose Testpoint	5012	Keystone		
TP2, TP4	2		Test Point, Multipurpose, Red, TH	Red Multipurpose Testpoint	5010	Keystone		
TP3	1		Test Point, Multipurpose, Orange, TH	Orange Multipurpose Testpoint	5013	Keystone		
TP5	1		Test Point, Multipurpose, Yellow, TH	Yellow Multipurpose Testpoint	5014	Keystone		
TP9, TP11	2		Test Point, Miniature, SMT	Test Point, Miniature, SMT	5019	Keystone		
TP10, TP12	2		Test Point, Multipurpose, Black, TH	Black Multipurpose Testpoint	5011	Keystone		
U1	1		Standalone 17V/3.0A Single Cell Battery Charger, RTE0016C (WQFN-16)	RTE0016C	BQ25308RTER	Texas Instruments	BQ25308RTET	Texas Instruments
C1	0	510pF	CAP, CERM, 510pF, 25V, ±5%, C0G/NP0, 0402	0402	GRM1555C1E511JA0 1D	MuRata		
C3	0	0.1µF	CAP, CERM, 0.1µF, 50V, ±10%, X7R, 0402	0402	C1005X7R1H104K05 0BB	TDK		
C4	0	10µF	CAP, CERM, 10µF, 16V, ±20%, X7R, 0805	0805	EMK212BB7106MG-T	Taiyo Yuden		
C7	0	2.2µF	CAP, CERM, 2.2µF, 35V, ±10%, X5R, 0603	0603	GRM188R6YA225KA 12D	MuRata		
C9	0	10µF	CAP, CERM, 10µF, 25V, ±10%, X5R, 0805	0805	CC0805KKX5R8BB10 6	Yageo		
C10	0	0.01µF	CAP, CERM, 0.01µF, 50V, ±10%, C0G/NP0, 0402	0402	GCM155R71H103KA 55D	MuRata		
C12	0	0.01µF	CAP, CERM, 0.01µF, 16V, ±10%, X7R, 0402	0402	C0402C103K4RACT U	Kemet		
D1	0	30V	Diode, Schottky, 30V, 1A, SOD-123	SOD-123	B130LAW-7-F	Diodes Inc.		

Table 4-1. BQ25308EVM Bill of Materials (continued)

Designator	Quantity	Value	Description	Package Reference	PartNumber	Manufacturer	Alternate Part Number ⁽¹⁾	Alternate Manufacturer ⁽¹⁾
FID1, FID2, FID3, FID4, FID5, FID6	0		Fiducial mark. There is nothing to buy or mount.	N/A	N/A	N/A		
JP4, JP5	0		Header, 100mil, 2x1, Tin, TH	Header, 2 PIN, 100mil, Tin	PEC02SAAN	Sullins Connector Solutions		
R1	0	1.00	RES, 1.00, 1%, 0.063 W, AEC-Q200 Grade 0, 0402	0402	CRCW04021R00FKE D	Vishay-Dale		
R5	0	562k	RES, 562 k, 1%, 0.063 W, AEC-Q200 Grade 0, 0402	0402	CRCW0402562KFKE D	Vishay-Dale		
R6	0	1.33Meg	RES, 1.33M, 1%, 0.063 W, AEC-Q200 Grade 0, 0402	0402	CRCW04021M33FKE D	Vishay-Dale		
R8	0	0	RES, 0, 5%, 0.063 W, 0402	0402	RC0402JR-070RL	Yageo America		
R12	0	200k	RES, 200 k, 1%, 0.063 W, AEC-Q200 Grade 0, 0402	0402	CRCW0402200KFKE D	Vishay-Dale		
SH-JP2, SH-JP3, SH-JP4, SH-JP5, SH-JP7, SH-JP8, SH-JP10	0	1x2	Shunt, 100mil, Gold plated, Black	Shunt	SNT-100-BK-G	Samtec	969102-0000-DA	3M

(1) Unless otherwise noted in the Alternate Part Number and/or Alternate Manufacturer columns, all parts can be substituted with equivalents.

5 Additional Information

5.1 Trademarks

All trademarks are the property of their respective owners.

STANDARD TERMS FOR EVALUATION MODULES

1. *Delivery:* TI delivers TI evaluation boards, kits, or modules, including any accompanying demonstration software, components, and/or documentation which may be provided together or separately (collectively, an "EVM" or "EVMs") to the User ("User") in accordance with the terms set forth herein. User's acceptance of the EVM is expressly subject to the following terms.
 - 1.1 EVMs are intended solely for product or software developers for use in a research and development setting to facilitate feasibility evaluation, experimentation, or scientific analysis of TI semiconductors products. EVMs have no direct function and are not finished products. EVMs shall not be directly or indirectly assembled as a part or subassembly in any finished product. For clarification, any software or software tools provided with the EVM ("Software") shall not be subject to the terms and conditions set forth herein but rather shall be subject to the applicable terms that accompany such Software
 - 1.2 EVMs are not intended for consumer or household use. EVMs may not be sold, sublicensed, leased, rented, loaned, assigned, or otherwise distributed for commercial purposes by Users, in whole or in part, or used in any finished product or production system.
2. *Limited Warranty and Related Remedies/Disclaimers:*
 - 2.1 These terms do not apply to Software. The warranty, if any, for Software is covered in the applicable Software License Agreement.
 - 2.2 TI warrants that the TI EVM will conform to TI's published specifications for ninety (90) days after the date TI delivers such EVM to User. Notwithstanding the foregoing, TI shall not be liable for a nonconforming EVM if (a) the nonconformity was caused by neglect, misuse or mistreatment by an entity other than TI, including improper installation or testing, or for any EVMs that have been altered or modified in any way by an entity other than TI, (b) the nonconformity resulted from User's design, specifications or instructions for such EVMs or improper system design, or (c) User has not paid on time. Testing and other quality control techniques are used to the extent TI deems necessary. TI does not test all parameters of each EVM. User's claims against TI under this Section 2 are void if User fails to notify TI of any apparent defects in the EVMs within ten (10) business days after delivery, or of any hidden defects with ten (10) business days after the defect has been detected.
 - 2.3 TI's sole liability shall be at its option to repair or replace EVMs that fail to conform to the warranty set forth above, or credit User's account for such EVM. TI's liability under this warranty shall be limited to EVMs that are returned during the warranty period to the address designated by TI and that are determined by TI not to conform to such warranty. If TI elects to repair or replace such EVM, TI shall have a reasonable time to repair such EVM or provide replacements. Repaired EVMs shall be warranted for the remainder of the original warranty period. Replaced EVMs shall be warranted for a new full ninety (90) day warranty period.

WARNING

Evaluation Kits are intended solely for use by technically qualified, professional electronics experts who are familiar with the dangers and application risks associated with handling electrical mechanical components, systems, and subsystems.

User shall operate the Evaluation Kit within TI's recommended guidelines and any applicable legal or environmental requirements as well as reasonable and customary safeguards. Failure to set up and/or operate the Evaluation Kit within TI's recommended guidelines may result in personal injury or death or property damage. Proper set up entails following TI's instructions for electrical ratings of interface circuits such as input, output and electrical loads.

NOTE:

EXPOSURE TO ELECTROSTATIC DISCHARGE (ESD) MAY CAUSE DEGRADATION OR FAILURE OF THE EVALUATION KIT; TI RECOMMENDS STORAGE OF THE EVALUATION KIT IN A PROTECTIVE ESD BAG.

3 Regulatory Notices:

3.1 United States

3.1.1 Notice applicable to EVMs not FCC-Approved:

FCC NOTICE: This kit is designed to allow product developers to evaluate electronic components, circuitry, or software associated with the kit to determine whether to incorporate such items in a finished product and software developers to write software applications for use with the end product. This kit is not a finished product and when assembled may not be resold or otherwise marketed unless all required FCC equipment authorizations are first obtained. Operation is subject to the condition that this product not cause harmful interference to licensed radio stations and that this product accept harmful interference. Unless the assembled kit is designed to operate under part 15, part 18 or part 95 of this chapter, the operator of the kit must operate under the authority of an FCC license holder or must secure an experimental authorization under part 5 of this chapter.

3.1.2 For EVMs annotated as FCC – FEDERAL COMMUNICATIONS COMMISSION Part 15 Compliant:

CAUTION

This device complies with part 15 of the FCC Rules. Operation is subject to the following two conditions: (1) This device may not cause harmful interference, and (2) this device must accept any interference received, including interference that may cause undesired operation.

Changes or modifications not expressly approved by the party responsible for compliance could void the user's authority to operate the equipment.

FCC Interference Statement for Class A EVM devices

NOTE: This equipment has been tested and found to comply with the limits for a Class A digital device, pursuant to part 15 of the FCC Rules. These limits are designed to provide reasonable protection against harmful interference when the equipment is operated in a commercial environment. This equipment generates, uses, and can radiate radio frequency energy and, if not installed and used in accordance with the instruction manual, may cause harmful interference to radio communications. Operation of this equipment in a residential area is likely to cause harmful interference in which case the user will be required to correct the interference at his own expense.

FCC Interference Statement for Class B EVM devices

NOTE: This equipment has been tested and found to comply with the limits for a Class B digital device, pursuant to part 15 of the FCC Rules. These limits are designed to provide reasonable protection against harmful interference in a residential installation. This equipment generates, uses and can radiate radio frequency energy and, if not installed and used in accordance with the instructions, may cause harmful interference to radio communications. However, there is no guarantee that interference will not occur in a particular installation. If this equipment does cause harmful interference to radio or television reception, which can be determined by turning the equipment off and on, the user is encouraged to try to correct the interference by one or more of the following measures:

- Reorient or relocate the receiving antenna.
- Increase the separation between the equipment and receiver.
- Connect the equipment into an outlet on a circuit different from that to which the receiver is connected.
- Consult the dealer or an experienced radio/TV technician for help.

3.2 Canada

3.2.1 For EVMs issued with an Industry Canada Certificate of Conformance to RSS-210 or RSS-247

Concerning EVMs Including Radio Transmitters:

This device complies with Industry Canada license-exempt RSSs. Operation is subject to the following two conditions:

(1) this device may not cause interference, and (2) this device must accept any interference, including interference that may cause undesired operation of the device.

Concernant les EVMs avec appareils radio:

Le présent appareil est conforme aux CNR d'Industrie Canada applicables aux appareils radio exempts de licence. L'exploitation est autorisée aux deux conditions suivantes: (1) l'appareil ne doit pas produire de brouillage, et (2) l'utilisateur de l'appareil doit accepter tout brouillage radioélectrique subi, même si le brouillage est susceptible d'en compromettre le fonctionnement.

Concerning EVMs Including Detachable Antennas:

Under Industry Canada regulations, this radio transmitter may only operate using an antenna of a type and maximum (or lesser) gain approved for the transmitter by Industry Canada. To reduce potential radio interference to other users, the antenna type and its gain should be so chosen that the equivalent isotropically radiated power (e.i.r.p.) is not more than that necessary for successful communication. This radio transmitter has been approved by Industry Canada to operate with the antenna types listed in the user guide with the maximum permissible gain and required antenna impedance for each antenna type indicated. Antenna types not included in this list, having a gain greater than the maximum gain indicated for that type, are strictly prohibited for use with this device.

Concernant les EVMs avec antennes détachables

Conformément à la réglementation d'Industrie Canada, le présent émetteur radio peut fonctionner avec une antenne d'un type et d'un gain maximal (ou inférieur) approuvé pour l'émetteur par Industrie Canada. Dans le but de réduire les risques de brouillage radioélectrique à l'intention des autres utilisateurs, il faut choisir le type d'antenne et son gain de sorte que la puissance isotrope rayonnée équivalente (p.i.r.e.) ne dépasse pas l'intensité nécessaire à l'établissement d'une communication satisfaisante. Le présent émetteur radio a été approuvé par Industrie Canada pour fonctionner avec les types d'antenne énumérés dans le manuel d'usage et ayant un gain admissible maximal et l'impédance requise pour chaque type d'antenne. Les types d'antenne non inclus dans cette liste, ou dont le gain est supérieur au gain maximal indiqué, sont strictement interdits pour l'exploitation de l'émetteur.

3.3 Japan

3.3.1 *Notice for EVMs delivered in Japan:* Please see http://www.tij.co.jp/llds/ti_ja/general/eStore/notice_01.page 日本国内に輸入される評価用キット、ボードについては、次のところをご覧ください。

<https://www.ti.com/ja-jp/legal/notice-for-evaluation-kits-delivered-in-japan.html>

3.3.2 *Notice for Users of EVMs Considered "Radio Frequency Products" in Japan:* EVMs entering Japan may not be certified by TI as conforming to Technical Regulations of Radio Law of Japan.

If User uses EVMs in Japan, not certified to Technical Regulations of Radio Law of Japan, User is required to follow the instructions set forth by Radio Law of Japan, which includes, but is not limited to, the instructions below with respect to EVMs (which for the avoidance of doubt are stated strictly for convenience and should be verified by User):

1. Use EVMs in a shielded room or any other test facility as defined in the notification #173 issued by Ministry of Internal Affairs and Communications on March 28, 2006, based on Sub-section 1.1 of Article 6 of the Ministry's Rule for Enforcement of Radio Law of Japan,
2. Use EVMs only after User obtains the license of Test Radio Station as provided in Radio Law of Japan with respect to EVMs, or
3. Use of EVMs only after User obtains the Technical Regulations Conformity Certification as provided in Radio Law of Japan with respect to EVMs. Also, do not transfer EVMs, unless User gives the same notice above to the transferee. Please note that if User does not follow the instructions above, User will be subject to penalties of Radio Law of Japan.

【無線電波を送信する製品の開発キットをお使いになる際の注意事項】 開発キットの中には技術基準適合証明を受けていないものがあります。技術適合証明を受けていないものご使用に際しては、電波法遵守のため、以下のいずれかの措置を取っていただく必要がありますのでご注意ください。

1. 電波法施行規則第6条第1項第1号に基づく平成18年3月28日総務省告示第173号で定められた電波暗室等の試験設備でご使用いただく。
2. 実験局の免許を取得後ご使用いただく。
3. 技術基準適合証明を取得後ご使用いただく。

なお、本製品は、上記の「ご使用にあたっての注意」を譲渡先、移転先に通知しない限り、譲渡、移転できないものとします。

上記を遵守頂けない場合は、電波法の罰則が適用される可能性があることをご留意ください。日本テキサス・インスツルメンツ株式会社
東京都新宿区西新宿 6 丁目 2 4 番 1 号
西新宿三井ビル

3.3.3 *Notice for EVMs for Power Line Communication:* Please see http://www.tij.co.jp/llds/ti_ja/general/eStore/notice_02.page

電力線搬送波通信についての開発キットをお使いになる際の注意事項については、次のところをご覧ください。 <https://www.ti.com/ja-jp/legal/notice-for-evaluation-kits-for-power-line-communication.html>

3.4 European Union

3.4.1 *For EVMs subject to EU Directive 2014/30/EU (Electromagnetic Compatibility Directive):*

This is a class A product intended for use in environments other than domestic environments that are connected to a low-voltage power-supply network that supplies buildings used for domestic purposes. In a domestic environment this product may cause radio interference in which case the user may be required to take adequate measures.

-
4. *EVM Use Restrictions and Warnings:*
 - 4.1 EVMS ARE NOT FOR USE IN FUNCTIONAL SAFETY AND/OR SAFETY CRITICAL EVALUATIONS, INCLUDING BUT NOT LIMITED TO EVALUATIONS OF LIFE SUPPORT APPLICATIONS.
 - 4.2 User must read and apply the user guide and other available documentation provided by TI regarding the EVM prior to handling or using the EVM, including without limitation any warning or restriction notices. The notices contain important safety information related to, for example, temperatures and voltages.
 - 4.3 *Safety-Related Warnings and Restrictions:*
 - 4.3.1 User shall operate the EVM within TI's recommended specifications and environmental considerations stated in the user guide, other available documentation provided by TI, and any other applicable requirements and employ reasonable and customary safeguards. Exceeding the specified performance ratings and specifications (including but not limited to input and output voltage, current, power, and environmental ranges) for the EVM may cause personal injury or death, or property damage. If there are questions concerning performance ratings and specifications, User should contact a TI field representative prior to connecting interface electronics including input power and intended loads. Any loads applied outside of the specified output range may also result in unintended and/or inaccurate operation and/or possible permanent damage to the EVM and/or interface electronics. Please consult the EVM user guide prior to connecting any load to the EVM output. If there is uncertainty as to the load specification, please contact a TI field representative. During normal operation, even with the inputs and outputs kept within the specified allowable ranges, some circuit components may have elevated case temperatures. These components include but are not limited to linear regulators, switching transistors, pass transistors, current sense resistors, and heat sinks, which can be identified using the information in the associated documentation. When working with the EVM, please be aware that the EVM may become very warm.
 - 4.3.2 EVMs are intended solely for use by technically qualified, professional electronics experts who are familiar with the dangers and application risks associated with handling electrical mechanical components, systems, and subsystems. User assumes all responsibility and liability for proper and safe handling and use of the EVM by User or its employees, affiliates, contractors or designees. User assumes all responsibility and liability to ensure that any interfaces (electronic and/or mechanical) between the EVM and any human body are designed with suitable isolation and means to safely limit accessible leakage currents to minimize the risk of electrical shock hazard. User assumes all responsibility and liability for any improper or unsafe handling or use of the EVM by User or its employees, affiliates, contractors or designees.
 - 4.4 User assumes all responsibility and liability to determine whether the EVM is subject to any applicable international, federal, state, or local laws and regulations related to User's handling and use of the EVM and, if applicable, User assumes all responsibility and liability for compliance in all respects with such laws and regulations. User assumes all responsibility and liability for proper disposal and recycling of the EVM consistent with all applicable international, federal, state, and local requirements.
 5. *Accuracy of Information:* To the extent TI provides information on the availability and function of EVMs, TI attempts to be as accurate as possible. However, TI does not warrant the accuracy of EVM descriptions, EVM availability or other information on its websites as accurate, complete, reliable, current, or error-free.
 6. *Disclaimers:*
 - 6.1 EXCEPT AS SET FORTH ABOVE, EVMS AND ANY MATERIALS PROVIDED WITH THE EVM (INCLUDING, BUT NOT LIMITED TO, REFERENCE DESIGNS AND THE DESIGN OF THE EVM ITSELF) ARE PROVIDED "AS IS" AND "WITH ALL FAULTS." TI DISCLAIMS ALL OTHER WARRANTIES, EXPRESS OR IMPLIED, REGARDING SUCH ITEMS, INCLUDING BUT NOT LIMITED TO ANY EPIDEMIC FAILURE WARRANTY OR IMPLIED WARRANTIES OF MERCHANTABILITY OR FITNESS FOR A PARTICULAR PURPOSE OR NON-INFRINGEMENT OF ANY THIRD PARTY PATENTS, COPYRIGHTS, TRADE SECRETS OR OTHER INTELLECTUAL PROPERTY RIGHTS.
 - 6.2 EXCEPT FOR THE LIMITED RIGHT TO USE THE EVM SET FORTH HEREIN, NOTHING IN THESE TERMS SHALL BE CONSTRUED AS GRANTING OR CONFERRING ANY RIGHTS BY LICENSE, PATENT, OR ANY OTHER INDUSTRIAL OR INTELLECTUAL PROPERTY RIGHT OF TI, ITS SUPPLIERS/LICENSORS OR ANY OTHER THIRD PARTY, TO USE THE EVM IN ANY FINISHED END-USER OR READY-TO-USE FINAL PRODUCT, OR FOR ANY INVENTION, DISCOVERY OR IMPROVEMENT, REGARDLESS OF WHEN MADE, CONCEIVED OR ACQUIRED.
 7. *USER'S INDEMNITY OBLIGATIONS AND REPRESENTATIONS.* USER WILL DEFEND, INDEMNIFY AND HOLD TI, ITS LICENSORS AND THEIR REPRESENTATIVES HARMLESS FROM AND AGAINST ANY AND ALL CLAIMS, DAMAGES, LOSSES, EXPENSES, COSTS AND LIABILITIES (COLLECTIVELY, "CLAIMS") ARISING OUT OF OR IN CONNECTION WITH ANY HANDLING OR USE OF THE EVM THAT IS NOT IN ACCORDANCE WITH THESE TERMS. THIS OBLIGATION SHALL APPLY WHETHER CLAIMS ARISE UNDER STATUTE, REGULATION, OR THE LAW OF TORT, CONTRACT OR ANY OTHER LEGAL THEORY, AND EVEN IF THE EVM FAILS TO PERFORM AS DESCRIBED OR EXPECTED.
-

8. *Limitations on Damages and Liability:*

8.1 *General Limitations.* IN NO EVENT SHALL TI BE LIABLE FOR ANY SPECIAL, COLLATERAL, INDIRECT, PUNITIVE, INCIDENTAL, CONSEQUENTIAL, OR EXEMPLARY DAMAGES IN CONNECTION WITH OR ARISING OUT OF THESE TERMS OR THE USE OF THE EVMS , REGARDLESS OF WHETHER TI HAS BEEN ADVISED OF THE POSSIBILITY OF SUCH DAMAGES. EXCLUDED DAMAGES INCLUDE, BUT ARE NOT LIMITED TO, COST OF REMOVAL OR REINSTALLATION, ANCILLARY COSTS TO THE PROCUREMENT OF SUBSTITUTE GOODS OR SERVICES, RETESTING, OUTSIDE COMPUTER TIME, LABOR COSTS, LOSS OF GOODWILL, LOSS OF PROFITS, LOSS OF SAVINGS, LOSS OF USE, LOSS OF DATA, OR BUSINESS INTERRUPTION. NO CLAIM, SUIT OR ACTION SHALL BE BROUGHT AGAINST TI MORE THAN TWELVE (12) MONTHS AFTER THE EVENT THAT GAVE RISE TO THE CAUSE OF ACTION HAS OCCURRED.

8.2 *Specific Limitations.* IN NO EVENT SHALL TI'S AGGREGATE LIABILITY FROM ANY USE OF AN EVM PROVIDED HEREUNDER, INCLUDING FROM ANY WARRANTY, INDEMNITY OR OTHER OBLIGATION ARISING OUT OF OR IN CONNECTION WITH THESE TERMS, , EXCEED THE TOTAL AMOUNT PAID TO TI BY USER FOR THE PARTICULAR EVM(S) AT ISSUE DURING THE PRIOR TWELVE (12) MONTHS WITH RESPECT TO WHICH LOSSES OR DAMAGES ARE CLAIMED. THE EXISTENCE OF MORE THAN ONE CLAIM SHALL NOT ENLARGE OR EXTEND THIS LIMIT.

9. *Return Policy.* Except as otherwise provided, TI does not offer any refunds, returns, or exchanges. Furthermore, no return of EVM(s) will be accepted if the package has been opened and no return of the EVM(s) will be accepted if they are damaged or otherwise not in a resalable condition. If User feels it has been incorrectly charged for the EVM(s) it ordered or that delivery violates the applicable order, User should contact TI. All refunds will be made in full within thirty (30) working days from the return of the components(s), excluding any postage or packaging costs.

10. *Governing Law:* These terms and conditions shall be governed by and interpreted in accordance with the laws of the State of Texas, without reference to conflict-of-laws principles. User agrees that non-exclusive jurisdiction for any dispute arising out of or relating to these terms and conditions lies within courts located in the State of Texas and consents to venue in Dallas County, Texas. Notwithstanding the foregoing, any judgment may be enforced in any United States or foreign court, and TI may seek injunctive relief in any United States or foreign court.

Mailing Address: Texas Instruments, Post Office Box 655303, Dallas, Texas 75265
Copyright © 2023, Texas Instruments Incorporated

IMPORTANT NOTICE AND DISCLAIMER

TI PROVIDES TECHNICAL AND RELIABILITY DATA (INCLUDING DATA SHEETS), DESIGN RESOURCES (INCLUDING REFERENCE DESIGNS), APPLICATION OR OTHER DESIGN ADVICE, WEB TOOLS, SAFETY INFORMATION, AND OTHER RESOURCES "AS IS" AND WITH ALL FAULTS, AND DISCLAIMS ALL WARRANTIES, EXPRESS AND IMPLIED, INCLUDING WITHOUT LIMITATION ANY IMPLIED WARRANTIES OF MERCHANTABILITY, FITNESS FOR A PARTICULAR PURPOSE OR NON-INFRINGEMENT OF THIRD PARTY INTELLECTUAL PROPERTY RIGHTS.

These resources are intended for skilled developers designing with TI products. You are solely responsible for (1) selecting the appropriate TI products for your application, (2) designing, validating and testing your application, and (3) ensuring your application meets applicable standards, and any other safety, security, regulatory or other requirements.

These resources are subject to change without notice. TI grants you permission to use these resources only for development of an application that uses the TI products described in the resource. Other reproduction and display of these resources is prohibited. No license is granted to any other TI intellectual property right or to any third party intellectual property right. TI disclaims responsibility for, and you will fully indemnify TI and its representatives against, any claims, damages, costs, losses, and liabilities arising out of your use of these resources.

TI's products are provided subject to [TI's Terms of Sale](#) or other applicable terms available either on [ti.com](https://www.ti.com) or provided in conjunction with such TI products. TI's provision of these resources does not expand or otherwise alter TI's applicable warranties or warranty disclaimers for TI products.

TI objects to and rejects any additional or different terms you may have proposed.

Mailing Address: Texas Instruments, Post Office Box 655303, Dallas, Texas 75265
Copyright © 2024, Texas Instruments Incorporated