

# EVM User's Guide: BQ25770GEVM, BQ25773GEVM BQ2577xGEVM Evaluation Module



## Description

The BQ2577xGEVM is a complete high-power high-efficiency battery charger using SMBus or I<sup>2</sup>C-controlled NVDC dual phase buck boost charge controller BQ2577xG. The EVM drives GAN FETs for high efficiency. The input voltage range is from 3.5V to 40V, with a programmable output of 2–5 cells and a charge current range of 0A to 16.3A. This BQ2577xGEVM allows the users to evaluate the function and performance of the BQ2577xG with step-by-step instructions. The BQ2577xGEVM also serves as a reference design with complete schematic, layout and Bill of Materials (BOM).

## Get Started

1. Order the BQ2577xGEVM from [ti.com](https://www.ti.com).
2. Download the latest [BQStudio GUI](#).
3. Follow this step-by-step user's guide.

## Features

- Supports 3.5V to 40V input source
  - 3.5V to 40V, 0A to 8.2A input operating range and 2–5 cell battery configuration
  - Supports USB 2.0, USB 3.0, USB 3.1 (USB Type-C®) and USB-C PD
  - Supports USB OTG with 3V to 5V adjustable output

- Supports Fast Role Swap (FRS) feature for USB\_PD
- High efficiency with GAN FETs
- Narrow VDC (NVDC) power path management
  - Battery supplements the system when the adapter is fully-loaded
- 600kHz or 800kHz switching frequency for low profile inductor
- SMBus (BQ25770G) or I<sup>2</sup>C(BQ25773G) port for best system performance and status reporting
- Power and current monitor for CPU throttling
- Safety
  - Thermal regulation and thermal shutdown
  - Input, system and battery overvoltage protection
  - Input, MOSFET and inductor overcurrent protection
- Supports Vmin Active Protection (VAP) mode for Intel® platform
- Charge status outputs for LED or host processor
- Test points available for key signals with easy probe hook-up
- Jumpers available for easy-to-change reconfiguration

## Applications

- [Standard notebook PC](#), [Chromebook™](#)
- [Appliances: battery charger](#), [oxygen concentrator](#)

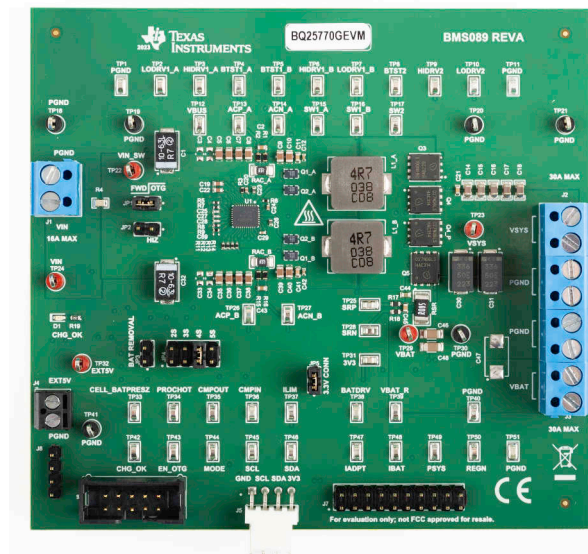

# 1 Evaluation Module Overview

## 1.1 Introduction

The BQ2577xGEVM evaluation module is designed for evaluating an SMBus or I<sup>2</sup>C-controlled buck boost charger BQ2577xG. The BQ2577xGEVM also serves as a reference design with complete schematic, layout and Bill of Materials (BOM). This user's guide describes the characteristics, operation, and use of the BQ2577xGEVM evaluation board.

## 1.2 Kit Contents

The evaluation kit includes a full power BQ2577xGEVM.

### Note

This EVM kit does not include the EV2400 interface device; the EV2400 must be ordered separately to evaluate the BQ2577xGEVM.

## 1.3 Specification

**Table 1-1. Recommended Operating Conditions**

Symbol	Description	MIN	TYP	MAX	Unit
Supply voltage, $V_{IN}$	Input voltage from AC adapter input	3.5		40	V
Battery voltage, $V_{BAT}$	Voltage applied at VBAT terminal	0		23	V
Supply current, $I_{AC}$	Maximum input current from AC adapter input (RAC=10 mΩ)	0		8.2	A
Output current, $I_{out}$	System current or charge current	0		16.3	A
Operating junction temperature range, $T_J$		0		125	°C

## 1.4 Device Information

The BQ2577xG is a synchronous NVDC buck-boost battery charge controller to charge a 2- to 5-cell battery from a wide range of input sources including USB adapters, extended power range (EPR) USB-C Power Delivery (PD) sources, standard power range (SPR) USB-C Power Delivery (PD) sources and traditional adapters. The BQ2577xG offers a low component count, high efficiency device for space constrained, 2- to 5-cell battery charging applications.

## 2 Hardware

### 2.1 General Description

The NVDC configuration allows the system to be regulated at the battery voltage, but does not drop below the system minimum voltage. The system keeps operating even when the battery is completely discharged or removed. When load power exceeds the input source rating, the battery supplement mode prevents the input source from being overloaded.

During power up, the charger sets the converter to buck, boost, or buck-boost configuration based on the input source and battery conditions. During the charging cycle, the charger automatically transits among buck, boost, and buck-boost configuration without host control.

The BQ2577xG monitors adapter current, battery current, and system power. The flexibly programmed PROCHOT output goes directly to the CPU for throttle back, when needed.

For more details, please see the [BQ2577xG: 40V, SMBus or I<sup>2</sup>C, 2- to 5-Cell, Narrow VDC Dual Phase Buck-Boost Battery Charge Controller for GaN HEMT With System Power Monitor and Processor Hot Monitor](#) data sheet.

Table 2-1 lists the I/O descriptions.

**Table 2-1. I/O Description**

Jack	Description
J1-VIN	Input: positive terminal
J1-PGND	Input: negative terminal (ground terminal)
J2-VSYS	Connected to system output
J2-PGND	Ground
J3-VBAT	Connected to battery pack output
J3-PGND	Ground
J4-EXT5V	Connected to external 5V supply
J4-PGND	Ground
J5-ILIM_HIZ	External converter disable
J5-CHRG_OK	CHRG_OK output
J5-EN_OTG	External OTG enable pin
J5-CELL_control	External battery removal control; logic high to pull the CELL pin down
J6-3V3	Onboard 3.3V output
J6-SDA	SMBUS or I <sup>2</sup> C SDA
J6-SCL	SMBUS or I <sup>2</sup> C SCL
J6-GND	Ground
J8-SDA	SMBUS or I <sup>2</sup> C SDA
J8-SCL	SMBUS or I <sup>2</sup> C SCL
J8-GND	Ground

Table 2-2 displays the controls and key parameters settings.

**Table 2-2. Controls and Key Parameters Setting**

Jumper	Description	Factory Setting
JP1	Jumper on: Bat removal Jumper off: Cell setting by JP4	Not installed
JP2	Jumper on: Forward Mode Jumper off: OTG Mode	Installed
JP3	For input current setting: Jumper on: Enter HiZ mode. Jumper off: Allow pre-bias EXTLIM	Not installed
JP4	CELL setting: 2S: JP4(1-2), measure CELL pin voltage 2V 3S: JP4(3-4), measure CELL pin voltage 2.75V 4S: JP4(5-6), measure CELL pin voltage 3.76V 5S: JP4(7-8), measure CELL pin voltage 5V	4S setting: JP4(5-6)
JP5	Jumper on: Onboard 3.3V LDO enabled Jumper off: Disconnect onboard 3.3V LDO	Installed

## 2.2 Definitions

This procedure details how to configure the BMS089 evaluation board. For the test procedure, the following naming conventions are followed. Refer to [Section 3.1](#) for details.

VXXX:	External voltage supply name (VIN, VSYS, VBAT).
LOADy:	External load name (LOADy).
V(TPyyy):	Voltage at internal test point TPyyy. For example, V(TP12) means the voltage at TP12.
V(Jxx):	Voltage at jack terminal Jxx.
V(TP(XXX)):	Voltage at test point "XXX". For example, V(ACDET) means the voltage at the test point which is marked as "ACDET".
V(XXX, YYY):	Voltage across point XXX and YYY.
I(JXX(YYY)):	Current going out from the YYY terminal of jack XX.
Jxx(BBB):	Terminal or pin BBB of jack xx.
JPxx ON :	Internal jumper JPxx terminals are shorted.
JPxx OFF:	Internal jumper JPxx terminals are open.
JPxx (-YY-) ON:	Internal jumper JPxx adjacent terminals marked as "YY" are shorted.
Measure: → A,B	Check specified parameters A, B. If measured values are not within specified limits, the device under test has failed.
Observe → A,B	Observe if A, B occurs. If A or B does not occur, the device under test has failed.

[Section 3.2](#) have locations for jumpers, test points, and individual components.

## 2.3 Equipment

The following list of equipment is required for EVM testing:

1. **Power Supplies:** A power supply capable of supplying 40V at 20A is required.
2. **Load #1:** A 40V, 20A system DC electronic load.
3. **Load #2 :** A Kepco load: BOP25-40MG, DC 0 to  $\pm 25$  V, 0 to  $\pm 40$  A (or higher), or equivalent.
4. **Meters:** Six Fluke 75 multimeters (three voltage meters and three current meters), or equivalent.
5. **Computer:** A computer with at least one USB port and a USB cable.
6. **EV2400 Communication Kit**
7. **Software:** Download and properly install bqStudio from <https://www.ti.com/tool/BQSTUDIO>.

## 2.4 Equipment Setup

The test setup for BMS089 is shown in Figure 2-1. Please refer to the test setup and follow the guidelines below.

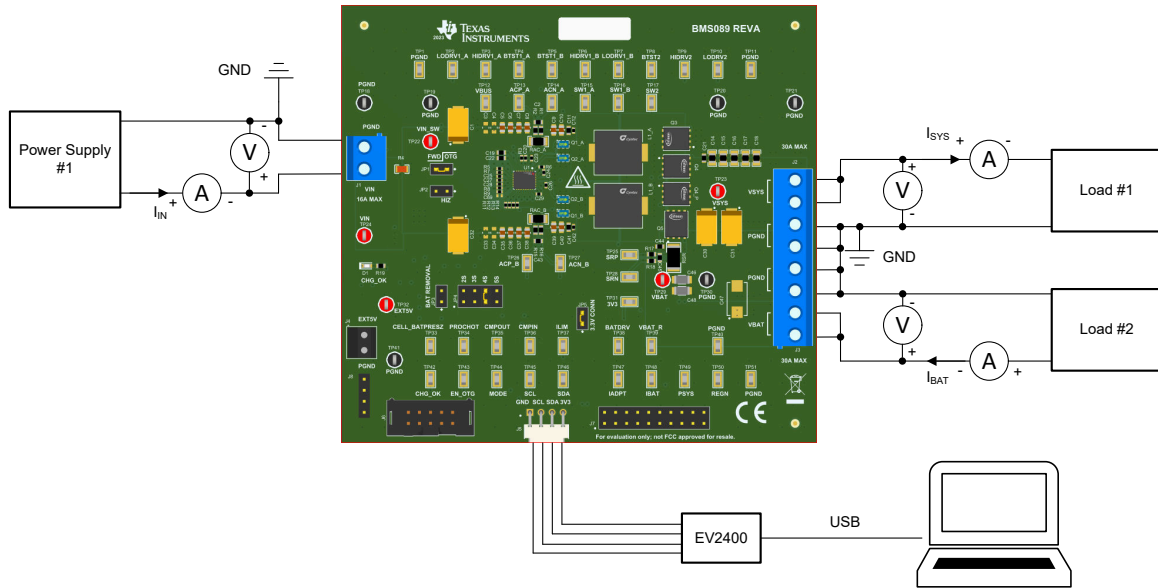

**Figure 2-1. Test Setup for BMS089 (BQ2577xGEVM)**

Use the following guidelines to set up the equipment:

1. Set power supply #1 for 20V DC, 9A current limit and then turn off the supply.
2. Connect the output of power supply #1 in series with a current meter to J1 (VIN and PGND).
3. Connect a voltage meter across J1 (VIN) and J1 (PGND).
4. Connect load #1 in series with a current meter to J2 (Vsys and PGND). Connect a voltage meter across J2 (Vsys and PGND). Set 2A at the constant current mode. Turn off load #1.
5. Connect Load #2 in series with a current meter to J3 (VBAT and PGND). Connect a voltage meter across J3 (VBAT and PGND). Set 15V at KEPCO load output. Turn off load #2.

### Note

Add a 100 $\mu$ F capacitor on the BAT pin when testing without a real battery.

Connect J8 to the EV2400. Connect J8 to the SMBus PORT 1 (BQ25770G) or I<sup>2</sup>C PORT 2 (BQ25773G) on the EV2400. Figure 2-2 shows the connections.

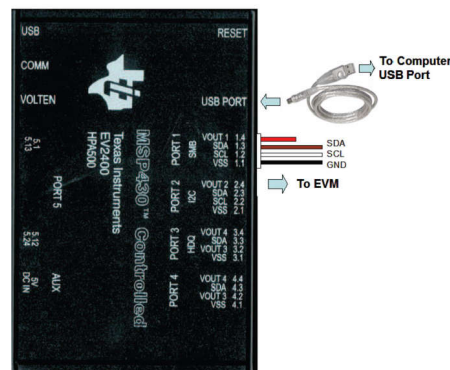

The figure shows the SMBus version EVM connection. If the user is using the BQ25773GEVM, then move the connector to the I<sup>2</sup>C port.

**Figure 2-2. EV2400 Connections**

1. Install jumpers as indicated in [Table 2-2](#).
2. Turn on the computer and power supply #1. Open the bqStudio software.
  - a. Select *Charger* and click the *Next* button.

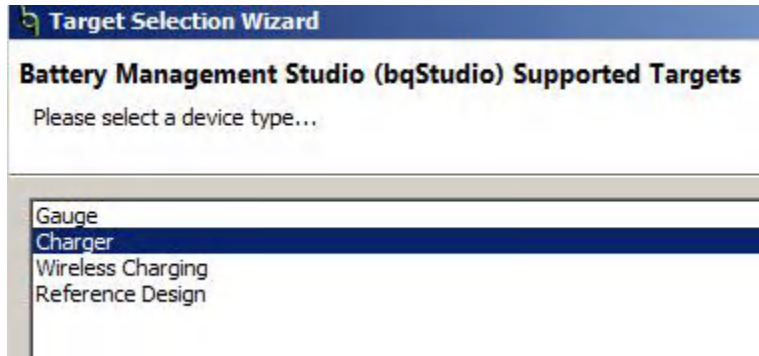

- b. For SMBus BQ25770G, select *Charger\_1\_00\_BQ25770\_770G.bqz* on the *Select a Target Page*. For I<sup>2</sup>C BQ25773G, select *Charger\_1\_00\_BQ25773\_773G.bqz* on the *Select a Target Page*.
- c. After selecting the target device, click the *Read Register* button and the interface in [Figure 2-3](#) is presented. *Device ACK OK* appears on the top right corner of window to indicate a successful communication.

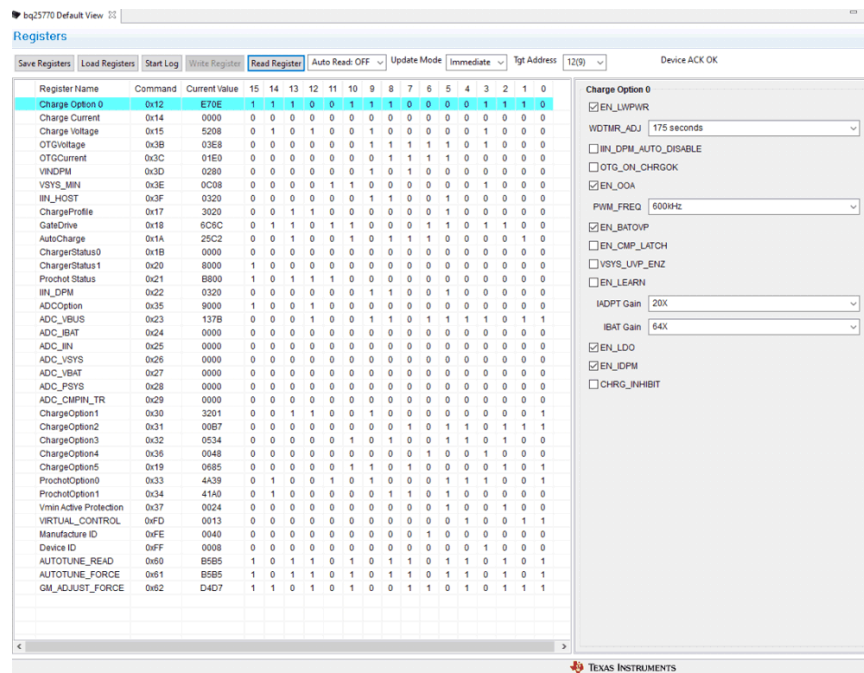

**Figure 2-3. Main Window of the BQ2577xG Evaluation Software**

## 2.5 Procedure

### 2.5.1 Charge Function

To evaluate the charge function, please follow below step-by-step instructions:

---

#### Note

To write registers using bqStudio software, change update mode to *Manual*, enter the new values in the *Current Value* column in the register map, press *Write Register* button, press *Read Register* to read back and confirm the write. Alternatively, the user can click each register bit or choose a value from the right-side panel, then press *Write Register* button.

---

1. Make sure the steps in [Section 2.4](#) are followed.
2. Set the power supply #1 to 20V, 9A current limit, then turn on the power supply.
3. Set the load #2 to 15V, then turn on load #2 (VBAT load).
4. Set the load #1 to 2A, then turn on load #1 (VSYS load).
5. Confirm the *Tgt Address* is *12(9)* for BQ25770G or *D6(6B)* for BQ25773G in BQStudio.
6. Disable Watchdog timer.  
Write *870E* to charge option 0 register .  
Measure →  $V(J1(V_{IN})) = 20V \pm 0.5 V$   
Measure →  $V(TP53(CHRG\_OK)) = 3V \text{ to } 4.5V$   
Measure →  $V(TP38(REGN)) = 5V \pm 1 V$   
Measure →  $V(TP54(ILIM\_HIZ)) = 3V$
7. Set inductor L/DCR time constant in AUTOTUNE\_FORCE register.  
Write *A8A8* to 0x61 register.
8. Set inductor DCR in GM\_ADJUST\_FORCE register.  
Write *B2B3* to 0x62 register.
9. Set Charge Voltage Register.  
Write "41A0" (16.8V) to charge voltage register.
10. Set Charge Current Register.  
Write "0800"(2048mA) to charge current register.
11. Measure →  $V(J2(SYS)) = 15V \pm 0.5V$   
Measure →  $V(J3(VBAT)) = 15V \pm 0.5V$   
Measure →  $I(J3(VBAT)) = 2A \pm 0.5A$ .

## 2.5.2 OTG Function

To evaluate the OTG function, please follow below step-by-step instructions:

1. Use load #2 as a battery source, set to 15V or connect a 15V power supply to J3.
2. Disconnect the power supply #1 from J1. (The connection must be physically removed from the board).
3. Connect load #1 to the J1.
4. Set inductor L/DCR time constant in AUTOTUNE\_FORCE register.  
Write "A8A8" to 0x61 register.
5. Set inductor DCR in GM\_ADJUST\_FORCE register.  
Write "B2B3" to 0x62 register.
6. Write 03E8 (5000mV) to the OTG voltage register.
7. Write 01E0 (3000mA) to the OTG current register.
8. Remove JP2 to enable the OTG function.
9. Check EN\_OTG bit in Charge Option 3 ON (EN\_OTG=1). See [Figure 2-4](#).
10. Set load #1 to 2A, then turn on the load.

Measure  $\rightarrow V(J1(V_{IN})) = 5V \pm 1V$

Measure  $\rightarrow I(J1(V_{IN})) = 2A \pm 0.5A$

The screenshot shows the TI Registers tool interface. The 'Registers' tab is active, and the 'Read Register' button is highlighted. The 'Tgt Address' is set to 12(9). The 'Device ACK' status is OK. The main table displays various registers, with 'ChargeOption3' (address 0x32) highlighted in blue. The current value of this register is 1534, and its binary representation is 000101010011001100. The bit at position 1 (EN\_OTG) is set to 1. On the right side, the 'ChargeOption3' configuration panel is visible, with the 'EN\_OTG' checkbox checked.

Register Name	Command	Current Value	15	14	13	12	11	10	9	8	7	6	5	4	3	2	1	0
Charge Option 0	0x12	E70E	1	1	1	0	0	1	1	1	0	0	0	0	0	1	1	0
Charge Current	0x14	0000	0	0	0	0	0	0	0	0	0	0	0	0	0	0	0	0
Charge Voltage	0x15	5208	0	1	0	1	0	0	1	0	0	0	0	0	0	1	0	0
OTG Voltage	0x3B	03E8	0	0	0	0	0	0	1	1	1	1	1	1	1	0	0	0
OTG Current	0x3C	01E0	0	0	0	0	0	0	0	1	1	1	1	1	0	0	0	0
VINDPM	0x3D	0290	0	0	0	0	0	1	0	1	0	0	0	0	0	0	0	0
VSYS_MIN	0x3E	0C08	0	0	0	0	1	1	0	0	0	0	0	0	1	0	0	0
IN_HOST	0x3F	0320	0	0	0	0	0	1	1	0	0	1	0	0	0	0	0	0
ChargeProfile	0x17	3020	0	0	1	1	0	0	0	0	0	0	0	0	1	0	0	0
GateDrive	0x18	6C6C	0	1	1	0	1	1	0	0	0	1	1	0	1	1	0	0
AutoCharge	0x1A	25C2	0	0	1	0	0	1	0	1	1	1	0	0	0	0	0	1
ChargerStatus0	0x1B	0000	0	0	0	0	0	0	0	0	0	0	0	0	0	0	0	0
ChargerStatus1	0x20	8000	1	0	0	0	0	0	0	0	0	0	0	0	0	0	0	0
Prochot Status	0x21	B800	1	0	1	1	1	0	0	0	0	0	0	0	0	0	0	0
IN_DPM	0x22	0320	0	0	0	0	0	0	1	1	0	0	1	0	0	0	0	0
ADCOption	0x35	9000	1	0	0	1	0	0	0	0	0	0	0	0	0	0	0	0
ADC_VBUS	0x23	137B	0	0	0	1	0	0	1	1	0	1	1	1	1	0	1	1
ADC_IBAT	0x24	0000	0	0	0	0	0	0	0	0	0	0	0	0	0	0	0	0
ADC_IN	0x25	0000	0	0	0	0	0	0	0	0	0	0	0	0	0	0	0	0
ADC_VSYS	0x26	0000	0	0	0	0	0	0	0	0	0	0	0	0	0	0	0	0
ADC_IBAT	0x27	0000	0	0	0	0	0	0	0	0	0	0	0	0	0	0	0	0
ADC_PSYS	0x28	0000	0	0	0	0	0	0	0	0	0	0	0	0	0	0	0	0
ADC_CMPN_TR	0x29	0000	0	0	0	0	0	0	0	0	0	0	0	0	0	0	0	0
ChargeOption1	0x30	3201	0	0	1	1	0	0	1	0	0	0	0	0	0	0	0	1
ChargeOption2	0x31	00B7	0	0	0	0	0	0	0	0	0	1	0	1	1	0	1	1
ChargeOption3	0x32	1534	0	0	0	1	0	1	0	1	0	1	0	0	1	1	0	1
ChargeOption4	0x36	0048	0	0	0	0	0	0	0	0	0	0	1	0	0	1	0	0
ChargeOption5	0x19	0685	0	0	0	0	0	1	1	0	1	0	0	0	0	1	0	1
ProchotOption0	0x33	4A39	0	1	0	0	1	0	1	0	0	0	0	1	1	1	0	0
ProchotOption1	0x34	41A0	0	1	0	0	0	0	0	1	1	0	1	0	0	0	0	0
Vmin Active Protection	0x37	0024	0	0	0	0	0	0	0	0	0	0	0	1	0	0	1	0
VIRTUAL_CONTROL	0xFD	0113	0	0	0	0	0	0	0	0	1	0	0	0	1	0	0	1
Manufacture ID	0xFE	0040	0	0	0	0	0	0	0	0	0	0	0	1	0	0	0	0
Device ID	0xFF	0008	0	0	0	0	0	0	0	0	0	0	0	0	1	0	0	0
AUTOTUNE_READ	0x60	B5B5	1	0	1	1	0	1	0	1	1	1	0	1	1	0	1	0
AUTOTUNE_FORCE	0x61	B5B5	1	0	1	1	0	1	0	1	1	0	1	1	0	1	0	1
GM_ADJUST_FORCE	0x62	D4D7	1	1	0	1	0	1	0	0	1	1	0	1	0	1	1	1

Figure 2-4. Check EN\_OTG bit in Charge Option 3 register



### 3 Hardware Design Files

#### 3.1 Schematic

Figure 3-1 shows the EVM schematic.

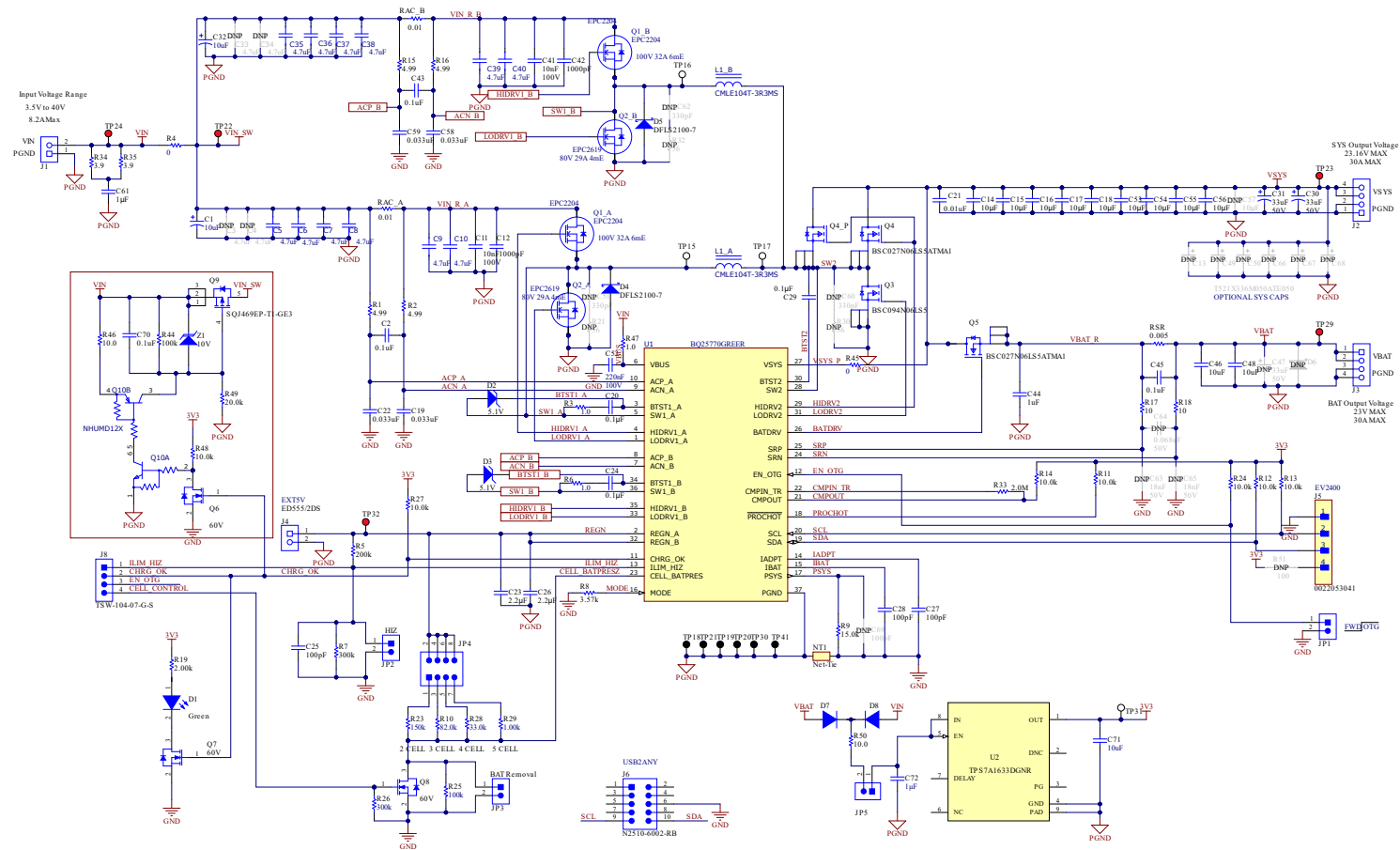

1. U1 is BQ25770G for BQ25770GEVM, while BQ25773G for BQ25773GEVM. 2. DNP means "Do Not Populate".

**Figure 3-1. BQ2577xGEVM Schematic**

### 3.2 PCB Layout

Figure 3-2 through Figure 3-9 illustrate the board assembly and layout images.

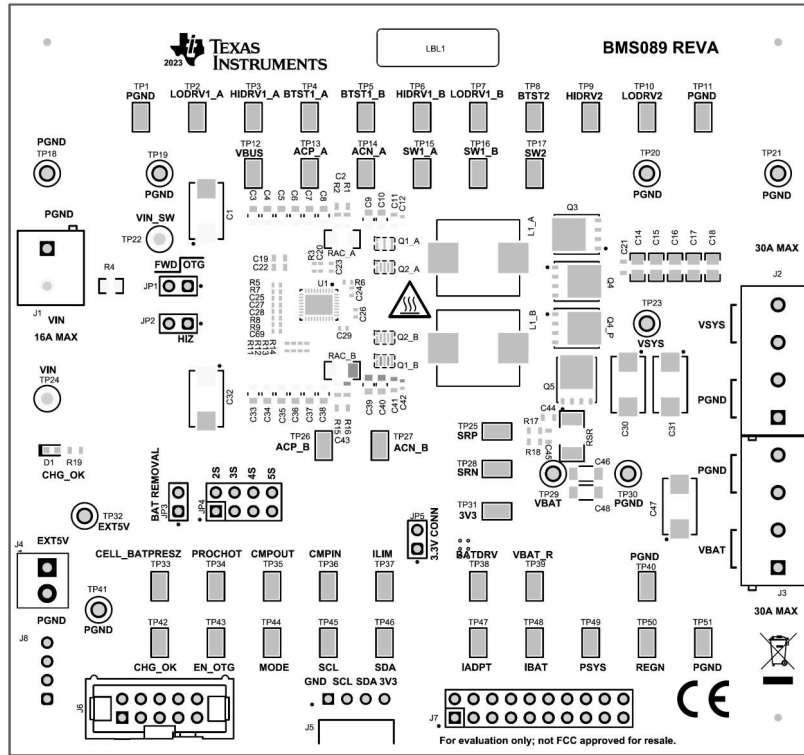

Figure 3-2. Top Assembly

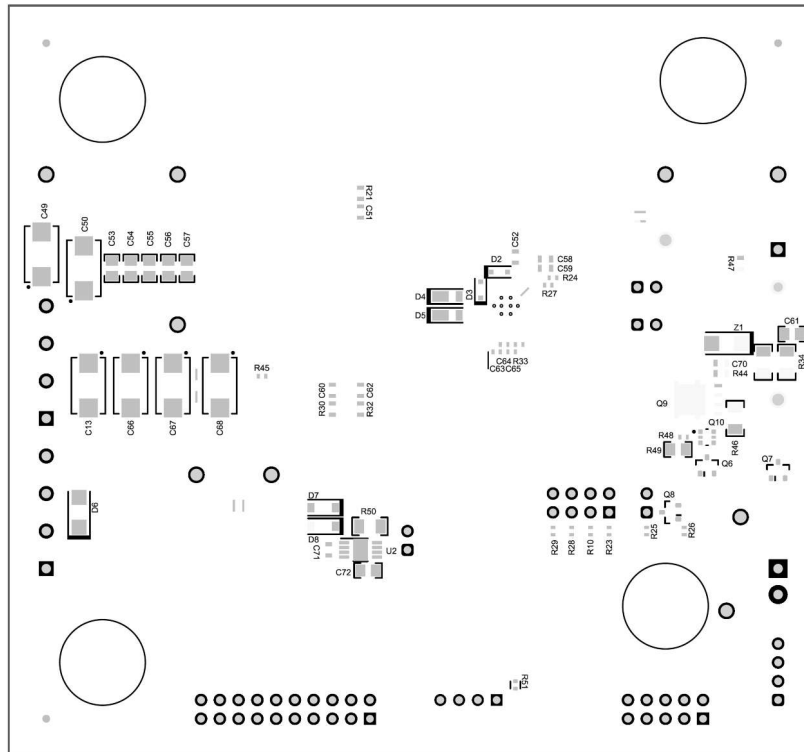

Figure 3-3. Bottom Assembly

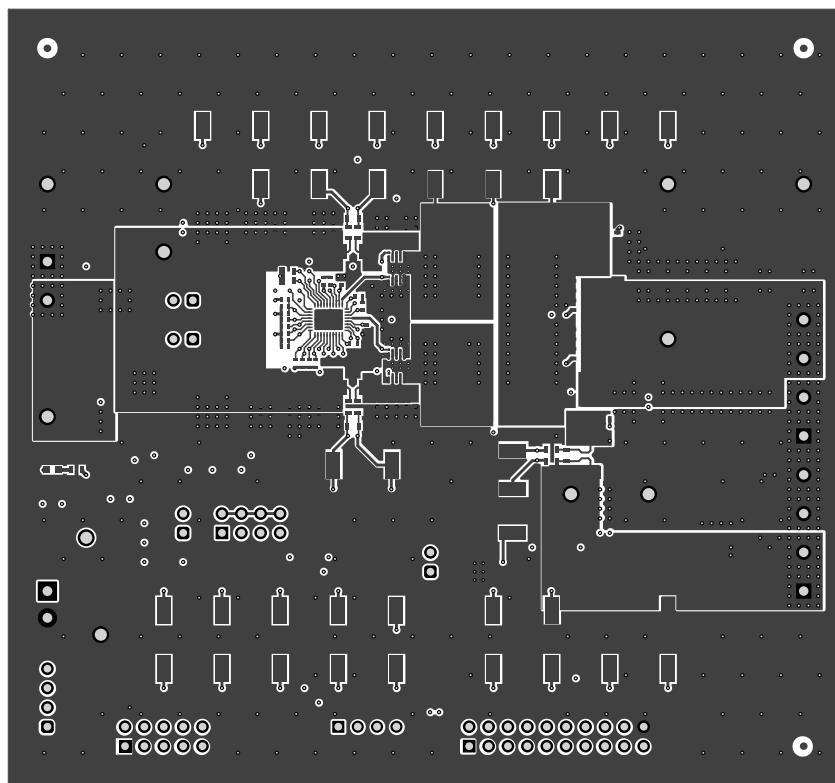

Figure 3-4. PCB Layer 1

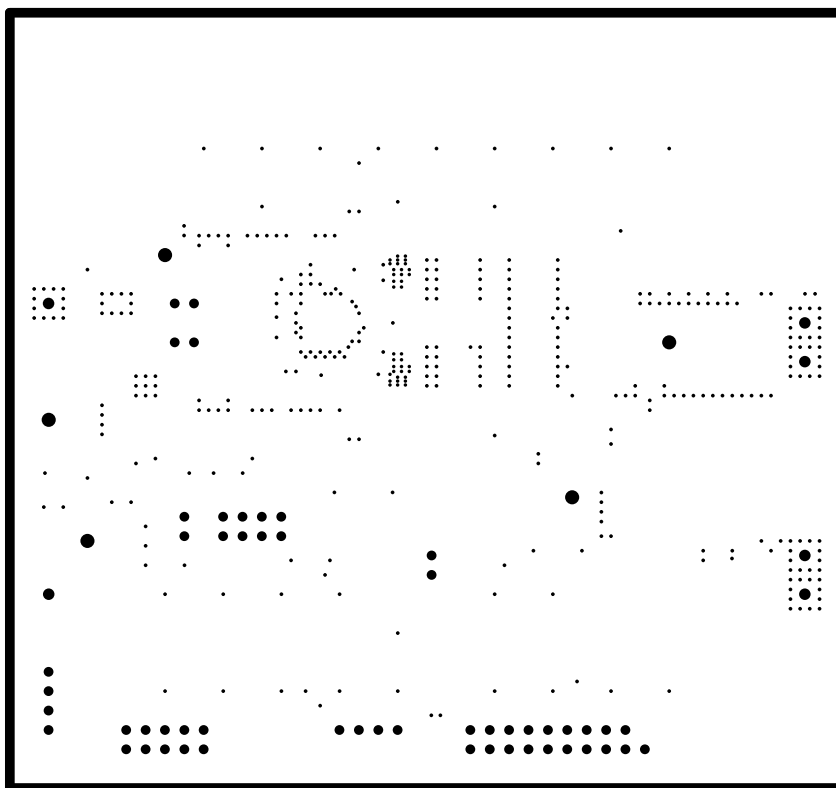
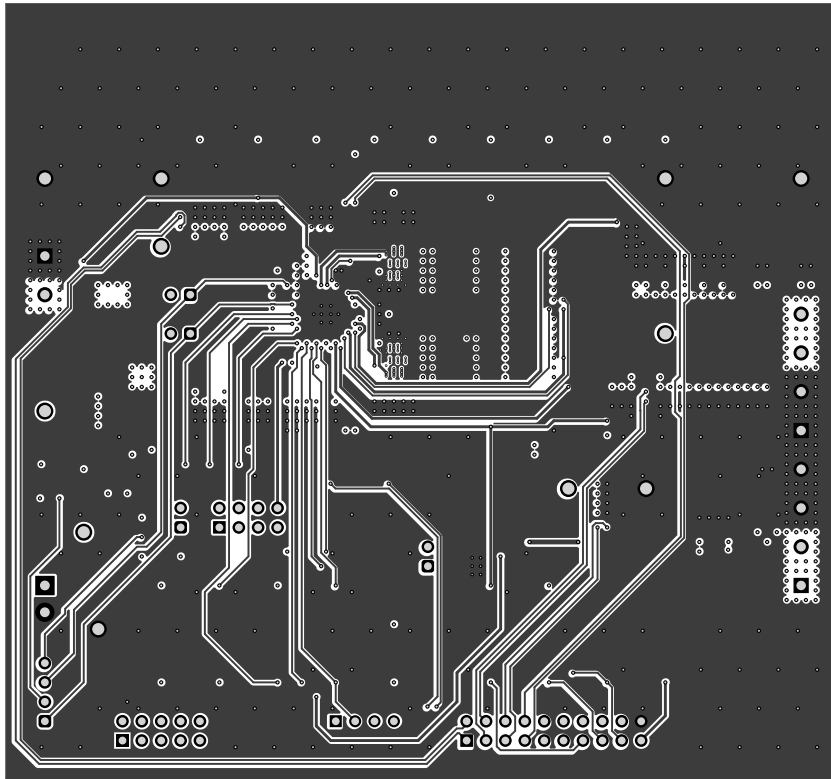
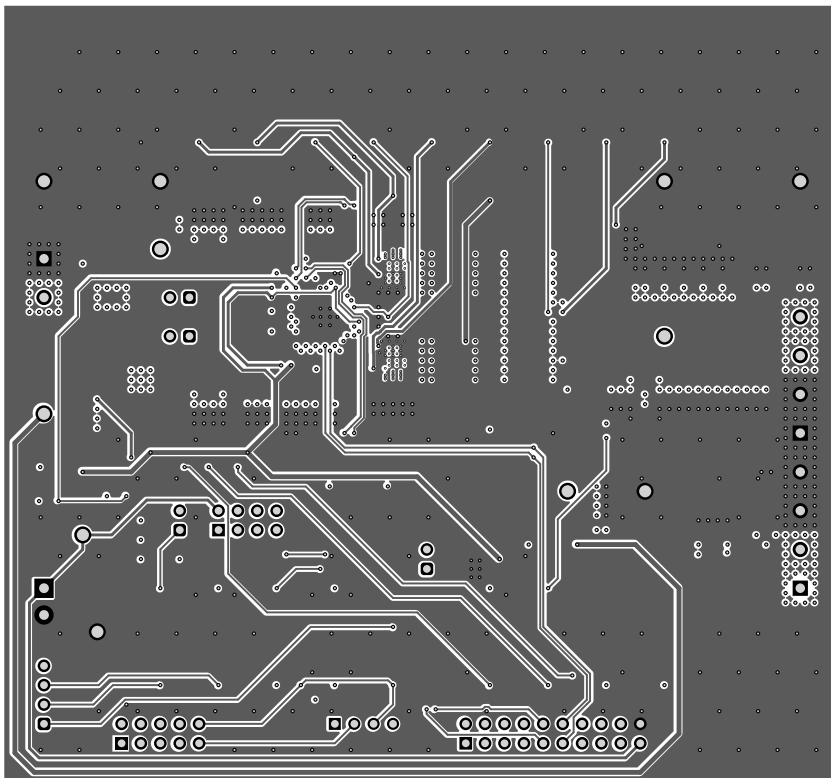

Figure 3-5. PCB Layer 2 (Negative)



**Figure 3-6. PCB Layer 3**



**Figure 3-7. PCB Layer 4**

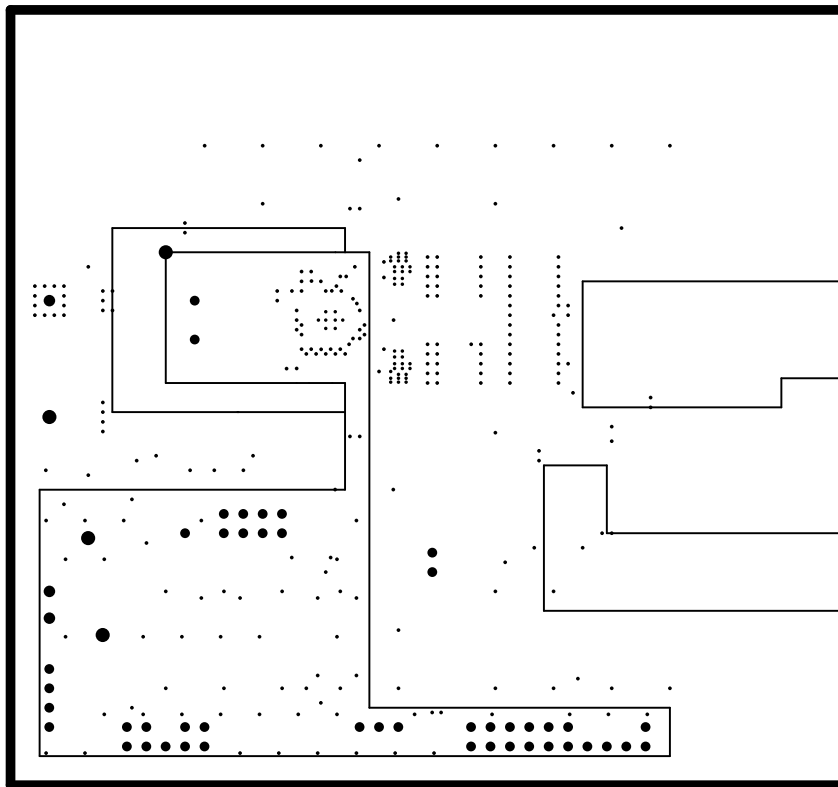

**Figure 3-8. PCB Layer 5 (Negative)**

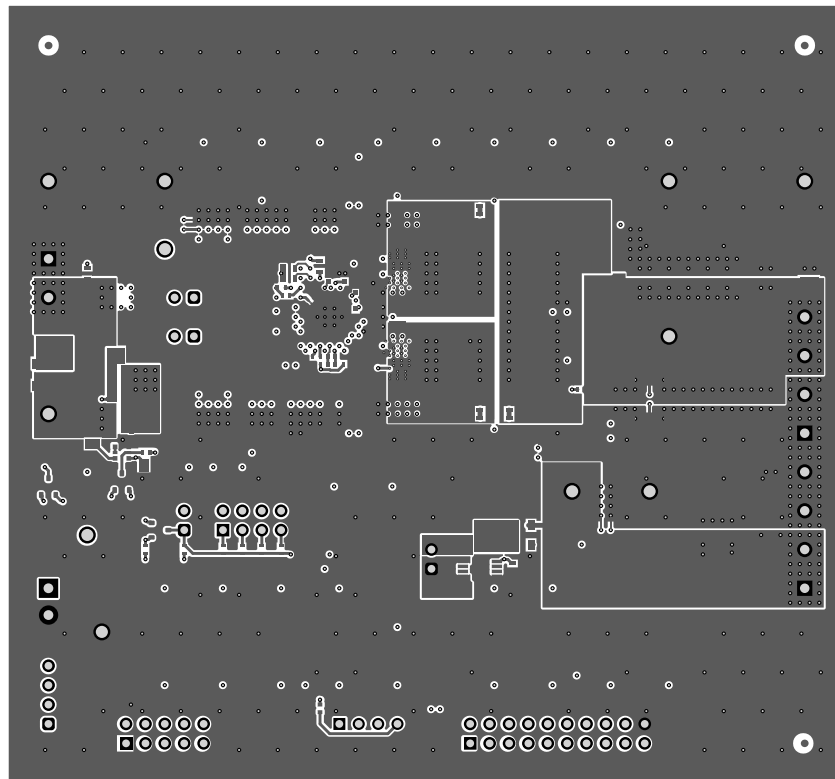

**Figure 3-9. PCB Layer 6**

### 3.3 Bill of Materials

Table 3-1 lists the BQ2577xEVM bill of materials.

**Table 3-1. BQ2577xEVM Bill of Materials**

Designator	Qty	Value	Description	Package Reference	Part Number	Manufacturer
!PCB1	1		Printed Circuit Board		BMS089	Any
C1, C32	2	10uF	CAP, TA, 10uF, 63V, +/- 10%, 0.6 ohm, SMD	7343-43	TR3E106K063C0600	Vishay-Sprague
C2, C43, C45, C70	4	0.1uF	CAP, CERM, 0.1uF, 50V, +/- 10%, X7R, AEC-Q200 Grade 1, 0603	603	CGA3E2X7R1H104K080AA	TDK
C5, C6, C7, C8, C9, C10, C35, C36, C37, C38, C39, C40	12	4.7uF	4.7uF ±10% 100V Ceramic Capacitor X5R 0805 (2012 Metric)	805	C2012X5R2A475K125AC	TDK
C11, C41	2	0.01uF	CAP, CERM, 0.01uF, 100V, +/- 5%, X7R, 0603	603	C0603C103J1RACTU	Kemet
C12, C42	2	1000pF	CAP, CERM, 1000pF, 100V, +/- 10%, X7R, 0402	402	GRM155R72A102KA01D	MuRata
C14, C15, C16, C17, C18, C53, C54, C55, C56	9	10uF	CAP, CERM, 10uF, 50V, +/- 10%, JB, 0805	805	GRM21BR61H106KE43L	muRata
C19, C22, C58, C59	4	0.033uF	CAP, CERM, 0.033uF, 100V, +/- 10%, X7S, AEC-Q200 Grade 1, 0603	603	CGA3E3X7S2A333K080AB	TDK
C20, C24, C29	3	0.1uF	CAP, CERM, 0.1uF, 25V, +/- 10%, X7R, AEC-Q200 Grade 1, 0402	402	CGA2B3X7R1E104K050BB	TDK
C21	1	0.01uF	CAP, CERM, 0.01uF, 50V, +/- 5%, X7R, 0603	603	C0603C103J5RACTU	Kemet
C23, C26	2	2.2uF	CAP, CERM, 2.2uF, 25V, +/- 20%, X5R, 0402	402	GRM155R61E225ME15D	MuRata
C25, C27, C28	3	100pF	CAP, CERM, 100pF, 50V, +/- 5%, C0G/NP0, 0402	402	GRM1555C1H101JA01D	MuRata
C30, C31	2	33uF	CAP, Tantalum Polymer, 33uF, 50V, +/- 20%, 0.05 ohm, 7343-43 SMD	7343-43	T521X336M050ATE050	Kemet
C44	1	1uF	CAP, CERM, 1uF, 50V, +/- 10%, X5R, 0603	603	C1608X5R1H105K080AB	TDK
C46, C48	2	10uF	CAP, CERM, 10uF, 35V, +/- 10%, X7R, 1206	1206	C3216X7R1V106K160AC	TDK
C52	1	0.22uF	CAP, CERM, 0.22uF, 100V, +/- 20%, X7S, AEC-Q200 Grade 1, 0603	603	HMK107C7224MAHTE	Taiyo Yuden
C61, C72	2	1uF	CAP, CERM, 1uF, 100V, +/- 10%, X7S, 0805	805	C2012X7S2A105K125AE	TDK
C71	1	10uF	CAP, CERM, 10uF, 35V, +/- 20%, X5R, 0603	603	GRM188R6YA106MA73D	Murata
D1	1	Green	LED, Green, SMD	1.6x0.8x0.8mm	LTST-C190GKT	Lite-On
D2, D3	2	5.1V	Diode, Zener, 5.1V, 400 mW, SOD-323F	SOD-323F	D3Z5V1BF-7	Diodes Inc.
D4, D5	2	100V	Diode, Schottky, 100V, 2A, PowerDI123	PowerDI123	DFLS2100-7	Diodes Inc.
D7, D8	2	100V	Diode, Switching, 100V, 0.3A, AEC-Q101, SOD-123	SOD-123	1N4148WQ-7-F	Diodes Inc.
H3, H4, H5, H6	4		Bumpon, Hemisphere, 0.44 X 0.20, Clear	Transparent Bumpon	SJ-5303 (CLEAR)	3M
J1	1		Terminal Block, 5.08mm, 2x1, Brass, TH	2x1 5.08mm Terminal Block	ED120/2DS	On-Shore Technology

**Table 3-1. BQ2577xEVM Bill of Materials (continued)**

Designator	Qty	Value	Description	Package Reference	Part Number	Manufacturer
J2, J3	2		Terminal Block, 5.08mm, 4x1, Brass, TH	4x1 5.08mm Terminal Block	ED120/4DS	On-Shore Technology
J4	1		Terminal Block, 3.5mm Pitch, 2x1, TH	7.0x8.2x6.5mm	ED555/2DS	On-Shore Technology
J5	1		Connector Header Through Hole, Right Angle 4 position 0.100" (2.54mm)	HDR4	22053041	Molex
J6	1		Header (shrouded), 100mil, 5x2, High-Temperature, Gold, TH	5x2 Shrouded header	N2510-6002-RB	3M
J7	1		Header, 100mil, 10x2, Gold, TH	10x2 Header	TSW-110-07-G-D	Samtec
J8	1		Header, 100mil, 4x1, Gold, TH	4x1 Header	TSW-104-07-G-S	Samtec
JP1, JP2, JP3, JP5	4		Header, 100mil, 2x1, Gold, TH	2x1 Header	TSW-102-07-G-S	Samtec
JP4	1		Header, 100mil, 4x2, Gold, TH	4x2 Header	TSW-104-07-G-D	Samtec
L1_A, L1_B	2		FIXED IND 3.3UH 10.7A 11.8 MOHM	SMT_IND_10MM85_1 0MM0	CMLE104T-3R3MS	Cyntec
LBL1	1		Thermal Transfer Printable Labels, 0.650" W x 0.200" H - 10,000 per roll	PCB Label 0.650 x 0.200 inch	THT-14-423-10	Brady
Q1_A, Q1_B	2		100V 32A 6mE		EPC2204	EPC
Q2_A, Q2_B	2		100V 29A 4mE		EPC2619	EPC
Q3	1		N-Channel 60V 100A (Tc) 83W (Tc) Surface Mount PG-TDSON-8-7	TDSON8	BSC094N06LS5	Infineon
Q4, Q4_P, Q5	3		N-Channel 60V 100A (Tc) 83W (Tc) Surface Mount PG-TDSON-8-7	TDSON8	BSC027N06LS5ATMA1	Infineon
Q6, Q7, Q8	3	60V	MOSFET, N-CH, 60V, 0.26A, SOT-23	SOT-23	2N7002ET1G	ON Semiconductor
Q9	1	-80V	MOSFET, P-CH, -80 V, -32 A, AEC-Q101, PowerPAK_SO-8L	PowerPAK_SO-8L	SQJ469EP-T1-GE3	Vishay-Siliconix
Q10	1	80V	Pre-Biased Bipolar Transistor (BJT) 1 NPN, 1 PNP - Pre-Biased (Dual) 80V 100mA 170MHz, 150MHz 350mW Surface Mount 6-TSSOP	TSSOP6	NHUMD12X	Nexperia
R1, R2, R15, R16	4	4.99	RES, 4.99, 1%, 0.1 W, AEC-Q200 Grade 0, 0603	603	CRCW06034R99FKEA	Vishay-Dale
R3, R6	2	1	RES, 1.0, 5%, 0.063 W, AEC-Q200 Grade 0, 0402	402	CRCW04021R00JNED	Vishay-Dale
R4	1	0	RES, 0, 1%, 0.5 W, 0805	805	5106	Keystone
R5	1	200k	RES, 200 k, 1%, 0.063 W, AEC-Q200 Grade 0, 0402	402	CRCW0402200KFKED	Vishay-Dale
R7, R26	2	300k	RES, 300 k, 1%, 0.063 W, AEC-Q200 Grade 0, 0402	402	CRCW0402300KFKED	Vishay-Dale
R8	1	3.57k	RES, 3.57 k, 1%, 0.063 W, AEC-Q200 Grade 0, 0402	402	CRCW04023K57FKED	Vishay-Dale
R9	1	15.0k	RES, 15.0 k, 1%, 0.063 W, AEC-Q200 Grade 0, 0402	402	CRCW040215K0FKED	Vishay-Dale

**Table 3-1. BQ2577xEVM Bill of Materials (continued)**

Designator	Qty	Value	Description	Package Reference	Part Number	Manufacturer
R10	1	82.0k	RES, 82.0 k, 1%, 0.063 W, 0402	402	RC0402FR-0782KL	Yageo America
R11, R12, R13, R14, R24, R27, R48	7	10.0k	RES, 10.0 k, 1%, 0.063 W, AEC-Q200 Grade 0, 0402	402	CRCW040210K0FKED	Vishay-Dale
R17, R18	2	10	RES, 10, 5%, 0.1 W, AEC-Q200 Grade 0, 0603	603	CRCW060310R0JNEA	Vishay-Dale
R19	1	2.00k	RES, 2.00 k, 1%, 0.1 W, AEC-Q200 Grade 0, 0603	603	CRCW06032K00FKEA	Vishay-Dale
R23	1	150k	RES, 150 k, 1%, 0.063 W, AEC-Q200 Grade 0, 0402	402	CRCW0402150KFKED	Vishay-Dale
R25	1	100k	RES, 100 k, 1%, 0.0625 W, 0402	402	RC0402FR-07100KL	Yageo America
R28	1	33.0k	RES, 33.0 k, 1%, 0.063 W, 0402	402	RC0402FR-0733KL	Yageo America
R29	1	1.00k	RES, 1.00 k, 1%, 0.063 W, AEC-Q200 Grade 0, 0402	402	CRCW04021K00FKED	Vishay-Dale
R33	1	2.0Meg	RES, 2.0M, 5%, 0.063 W, AEC-Q200 Grade 0, 0402	402	CRCW04022M00JNED	Vishay-Dale
R34, R35	2	3.9	RES, 3.9, 5%, 0.25 W, AEC-Q200 Grade 0, 1206	1206	CRCW12063R90JNEA	Vishay-Dale
R44	1	100k	RES, 100 k, 1%, 0.1 W, 0603	603	RC0603FR-07100KL	Yageo
R45	1	0	RES, 0, 5%, 0.063 W, AEC-Q200 Grade 0, 0402	402	CRCW04020000Z0ED	Vishay-Dale
R46, R50	2	10	RES, 10.0, 1%, 0.25 W, AEC-Q200 Grade 0, 1206	1206	ERJ-8ENF10R0V	Panasonic
R47	1	1	RES, 1.0, 5%, 0.1 W, AEC-Q200 Grade 0, 0603	603	CRCW06031R00JNEA	Vishay-Dale
R49	1	20.0k	RES, 20.0 k, 1%, 0.125 W, AEC-Q200 Grade 0, 0805	805	CRCW080520K0FKEA	Vishay-Dale
RAC_A, RAC_B	2	0.01	RES, 0.01, 1%, 1 W, 1206	1206	WSLP1206R0100FEA	Vishay-Dale
RSR	1	0.005	RES, 0.005, 1%, 1.5 W, 2010	2010	CSNL2010FT5L00	Stackpole Electronics Inc
SH-JP1, SH-JP4, SH- JP5	3	1x2	Shunt, 100mil, Gold plated, Black	Shunt	SNT-100-BK-G	Samtec
TP1, TP2, TP3, TP4, TP5, TP6, TP7, TP8, TP9, TP10, TP11, TP12, TP13, TP14, TP15, TP16, TP17, TP25, TP26, TP27, TP28, TP31, TP33, TP34, TP35, TP36, TP37, TP38, TP39, TP40, TP42, TP43, TP44, TP45, TP46, TP47, TP48, TP49, TP50, TP51	40		Test Point, Miniature, SMT	Test point_Keystone_Minia ture	5015	Keystone Electronics
TP18, TP19, TP20, TP21, TP30, TP41	6		Test Point, Multipurpose, Black, TH	Black Multipurpose Test point	5011	Keystone Electronics
TP22, TP23, TP24, TP29, TP32	5		Test Point, Multipurpose, Red, TH	Red Multipurpose Test point	5010	Keystone Electronics



**Table 3-1. BQ2577xEVM Bill of Materials (continued)**

Designator	Qty	Value	Description	Package Reference	Part Number	Manufacturer
U1	1		40V, SMBus, 2- to 5-Cell, Narrow VDC Quasi Dual Phase Buck-Boost Battery Charge Controller With System Power Monitor and Processor Hot Monitor	WQFN36	BQ25770GREER (BQ25773GREER)	Texas Instruments
U2	1		60V, 5uA IQ Low-Dropout 100mA Linear Regulator with Enable and Power Good, DGN0008C (VSSOP-8)	DGN0008C	TPS7A1633DGNR	Texas Instruments
Z1	1	10V	Diode, TVS, Uni, 10V, 17 Vc, 400 W, 23.5A, SMA	SMA	SMAJ10A	Littelfuse
C3, C4, C33, C34	0	4.7µF	4.7µF ±10% 100V Ceramic Capacitor X5R 0805 (2012 Metric)	805	C2012X5R2A475K125AC	TDK
C13, C47, C49, C50, C66, C67, C68	0	33uF	CAP, Tantalum Polymer, 33uF, 50V, +/- 20%, 0.05 ohm, 7343-43 SMD	7343-43	T521X336M050ATE050	Kemet
C51, C60, C62	0	330pF	CAP, CERM, 330pF, 50V, +/- 10%, X7R, 0603	603	GRM188R71H331KA01D	MuRata
C57	0	10uF	CAP, CERM, 10µF, 50V, +/- 10%, JB, 0805	805	GRM21BR61H106KE43L	muRata
C63, C65	0	0.018uF	CAP, CERM, 0.018uF, 50V, +/- 10%, X7R, 0402	402	GRM155R71H183KA12D	MuRata
C64	0	0.068uF	CAP, CERM, 0.068uF, 50V, +/- 10%, X7R, AEC-Q200 Grade 1, 0402	402	CGA2B3X7R1H683K050BB	TDK
C69	0	100pF	CAP, CERM, 100pF, 50V, +/- 5%, C0G/NP0, 0402	402	GRM1555C1H101JA01D	MuRata
D6	0	40V	Diode, Schottky, 40V, 2A, SMA	SMA	B240A-13-F	Diodes Inc.
R21, R30, R32	0	56	RES, 56, 5%, 0.1 W, AEC-Q200 Grade 0, 0603	603	CRCW060356R0JNEA	Vishay-Dale
R51	0	100	100 ±5% 0.063W, 1/16W Chip Resistor 0402 (1005 Metric) Moisture Resistant Thick Film	402	RC0402JR-13100RL	Yageo
SH-JP2, SH-JP3	0	1x2	Shunt, 100mil, Gold plated, Black	Shunt	SNT-100-BK-G	Samtec

## 4 Additional Information

### 4.1 Trademarks

Chromebook™ is a trademark of Google LLC.

USB Type-C® is a registered trademark of USB Implementer's Forum, Inc..

Intel® is a registered trademark of Intel.

All trademarks are the property of their respective owners.

## STANDARD TERMS FOR EVALUATION MODULES

1. *Delivery:* TI delivers TI evaluation boards, kits, or modules, including any accompanying demonstration software, components, and/or documentation which may be provided together or separately (collectively, an "EVM" or "EVMs") to the User ("User") in accordance with the terms set forth herein. User's acceptance of the EVM is expressly subject to the following terms.
  - 1.1 EVMs are intended solely for product or software developers for use in a research and development setting to facilitate feasibility evaluation, experimentation, or scientific analysis of TI semiconductor products. EVMs have no direct function and are not finished products. EVMs shall not be directly or indirectly assembled as a part or subassembly in any finished product. For clarification, any software or software tools provided with the EVM ("Software") shall not be subject to the terms and conditions set forth herein but rather shall be subject to the applicable terms that accompany such Software
  - 1.2 EVMs are not intended for consumer or household use. EVMs may not be sold, sublicensed, leased, rented, loaned, assigned, or otherwise distributed for commercial purposes by Users, in whole or in part, or used in any finished product or production system.
2. *Limited Warranty and Related Remedies/Disclaimers:*
  - 2.1 These terms do not apply to Software. The warranty, if any, for Software is covered in the applicable Software License Agreement.
  - 2.2 TI warrants that the TI EVM will conform to TI's published specifications for ninety (90) days after the date TI delivers such EVM to User. Notwithstanding the foregoing, TI shall not be liable for a nonconforming EVM if (a) the nonconformity was caused by neglect, misuse or mistreatment by an entity other than TI, including improper installation or testing, or for any EVMs that have been altered or modified in any way by an entity other than TI, (b) the nonconformity resulted from User's design, specifications or instructions for such EVMs or improper system design, or (c) User has not paid on time. Testing and other quality control techniques are used to the extent TI deems necessary. TI does not test all parameters of each EVM. User's claims against TI under this Section 2 are void if User fails to notify TI of any apparent defects in the EVMs within ten (10) business days after delivery, or of any hidden defects with ten (10) business days after the defect has been detected.
  - 2.3 TI's sole liability shall be at its option to repair or replace EVMs that fail to conform to the warranty set forth above, or credit User's account for such EVM. TI's liability under this warranty shall be limited to EVMs that are returned during the warranty period to the address designated by TI and that are determined by TI not to conform to such warranty. If TI elects to repair or replace such EVM, TI shall have a reasonable time to repair such EVM or provide replacements. Repaired EVMs shall be warranted for the remainder of the original warranty period. Replaced EVMs shall be warranted for a new full ninety (90) day warranty period.

### **WARNING**

**Evaluation Kits are intended solely for use by technically qualified, professional electronics experts who are familiar with the dangers and application risks associated with handling electrical mechanical components, systems, and subsystems.**

**User shall operate the Evaluation Kit within TI's recommended guidelines and any applicable legal or environmental requirements as well as reasonable and customary safeguards. Failure to set up and/or operate the Evaluation Kit within TI's recommended guidelines may result in personal injury or death or property damage. Proper set up entails following TI's instructions for electrical ratings of interface circuits such as input, output and electrical loads.**

**NOTE:**

**EXPOSURE TO ELECTROSTATIC DISCHARGE (ESD) MAY CAUSE DEGRADATION OR FAILURE OF THE EVALUATION KIT; TI RECOMMENDS STORAGE OF THE EVALUATION KIT IN A PROTECTIVE ESD BAG.**

### 3 Regulatory Notices:

#### 3.1 United States

##### 3.1.1 Notice applicable to EVMs not FCC-Approved:

**FCC NOTICE:** This kit is designed to allow product developers to evaluate electronic components, circuitry, or software associated with the kit to determine whether to incorporate such items in a finished product and software developers to write software applications for use with the end product. This kit is not a finished product and when assembled may not be resold or otherwise marketed unless all required FCC equipment authorizations are first obtained. Operation is subject to the condition that this product not cause harmful interference to licensed radio stations and that this product accept harmful interference. Unless the assembled kit is designed to operate under part 15, part 18 or part 95 of this chapter, the operator of the kit must operate under the authority of an FCC license holder or must secure an experimental authorization under part 5 of this chapter.

##### 3.1.2 For EVMs annotated as FCC – FEDERAL COMMUNICATIONS COMMISSION Part 15 Compliant:

#### **CAUTION**

This device complies with part 15 of the FCC Rules. Operation is subject to the following two conditions: (1) This device may not cause harmful interference, and (2) this device must accept any interference received, including interference that may cause undesired operation.

Changes or modifications not expressly approved by the party responsible for compliance could void the user's authority to operate the equipment.

#### **FCC Interference Statement for Class A EVM devices**

*NOTE: This equipment has been tested and found to comply with the limits for a Class A digital device, pursuant to part 15 of the FCC Rules. These limits are designed to provide reasonable protection against harmful interference when the equipment is operated in a commercial environment. This equipment generates, uses, and can radiate radio frequency energy and, if not installed and used in accordance with the instruction manual, may cause harmful interference to radio communications. Operation of this equipment in a residential area is likely to cause harmful interference in which case the user will be required to correct the interference at his own expense.*

#### **FCC Interference Statement for Class B EVM devices**

*NOTE: This equipment has been tested and found to comply with the limits for a Class B digital device, pursuant to part 15 of the FCC Rules. These limits are designed to provide reasonable protection against harmful interference in a residential installation. This equipment generates, uses and can radiate radio frequency energy and, if not installed and used in accordance with the instructions, may cause harmful interference to radio communications. However, there is no guarantee that interference will not occur in a particular installation. If this equipment does cause harmful interference to radio or television reception, which can be determined by turning the equipment off and on, the user is encouraged to try to correct the interference by one or more of the following measures:*

- Reorient or relocate the receiving antenna.
- Increase the separation between the equipment and receiver.
- Connect the equipment into an outlet on a circuit different from that to which the receiver is connected.
- Consult the dealer or an experienced radio/TV technician for help.

#### 3.2 Canada

##### 3.2.1 For EVMs issued with an Industry Canada Certificate of Conformance to RSS-210 or RSS-247

#### **Concerning EVMs Including Radio Transmitters:**

This device complies with Industry Canada license-exempt RSSs. Operation is subject to the following two conditions:

(1) this device may not cause interference, and (2) this device must accept any interference, including interference that may cause undesired operation of the device.

#### **Concernant les EVMs avec appareils radio:**

Le présent appareil est conforme aux CNR d'Industrie Canada applicables aux appareils radio exempts de licence. L'exploitation est autorisée aux deux conditions suivantes: (1) l'appareil ne doit pas produire de brouillage, et (2) l'utilisateur de l'appareil doit accepter tout brouillage radioélectrique subi, même si le brouillage est susceptible d'en compromettre le fonctionnement.

#### **Concerning EVMs Including Detachable Antennas:**

Under Industry Canada regulations, this radio transmitter may only operate using an antenna of a type and maximum (or lesser) gain approved for the transmitter by Industry Canada. To reduce potential radio interference to other users, the antenna type and its gain should be so chosen that the equivalent isotropically radiated power (e.i.r.p.) is not more than that necessary for successful communication. This radio transmitter has been approved by Industry Canada to operate with the antenna types listed in the user guide with the maximum permissible gain and required antenna impedance for each antenna type indicated. Antenna types not included in this list, having a gain greater than the maximum gain indicated for that type, are strictly prohibited for use with this device.

### Concernant les EVMs avec antennes détachables

Conformément à la réglementation d'Industrie Canada, le présent émetteur radio peut fonctionner avec une antenne d'un type et d'un gain maximal (ou inférieur) approuvé pour l'émetteur par Industrie Canada. Dans le but de réduire les risques de brouillage radioélectrique à l'intention des autres utilisateurs, il faut choisir le type d'antenne et son gain de sorte que la puissance isotrope rayonnée équivalente (p.i.r.e.) ne dépasse pas l'intensité nécessaire à l'établissement d'une communication satisfaisante. Le présent émetteur radio a été approuvé par Industrie Canada pour fonctionner avec les types d'antenne énumérés dans le manuel d'usage et ayant un gain admissible maximal et l'impédance requise pour chaque type d'antenne. Les types d'antenne non inclus dans cette liste, ou dont le gain est supérieur au gain maximal indiqué, sont strictement interdits pour l'exploitation de l'émetteur.

#### 3.3 Japan

3.3.1 *Notice for EVMs delivered in Japan:* Please see [http://www.tij.co.jp/lstds/ti\\_ja/general/eStore/notice\\_01.page](http://www.tij.co.jp/lstds/ti_ja/general/eStore/notice_01.page) 日本国内に輸入される評価用キット、ボードについては、次のところをご覧ください。

<https://www.ti.com/ja-jp/legal/notice-for-evaluation-kits-delivered-in-japan.html>

3.3.2 *Notice for Users of EVMs Considered "Radio Frequency Products" in Japan:* EVMs entering Japan may not be certified by TI as conforming to Technical Regulations of Radio Law of Japan.

If User uses EVMs in Japan, not certified to Technical Regulations of Radio Law of Japan, User is required to follow the instructions set forth by Radio Law of Japan, which includes, but is not limited to, the instructions below with respect to EVMs (which for the avoidance of doubt are stated strictly for convenience and should be verified by User):

1. Use EVMs in a shielded room or any other test facility as defined in the notification #173 issued by Ministry of Internal Affairs and Communications on March 28, 2006, based on Sub-section 1.1 of Article 6 of the Ministry's Rule for Enforcement of Radio Law of Japan,
2. Use EVMs only after User obtains the license of Test Radio Station as provided in Radio Law of Japan with respect to EVMs, or
3. Use of EVMs only after User obtains the Technical Regulations Conformity Certification as provided in Radio Law of Japan with respect to EVMs. Also, do not transfer EVMs, unless User gives the same notice above to the transferee. Please note that if User does not follow the instructions above, User will be subject to penalties of Radio Law of Japan.

【無線電波を送信する製品の開発キットをお使いになる際の注意事項】 開発キットの中には技術基準適合証明を受けていないものがあります。技術適合証明を受けていないものご使用に際しては、電波法遵守のため、以下のいずれかの措置を取っていただく必要がありますのでご注意ください。

1. 電波法施行規則第6条第1項第1号に基づく平成18年3月28日総務省告示第173号で定められた電波暗室等の試験設備でご使用いただく。
2. 実験局の免許を取得後ご使用いただく。
3. 技術基準適合証明を取得後ご使用いただく。

なお、本製品は、上記の「ご使用にあたっての注意」を譲渡先、移転先に通知しない限り、譲渡、移転できないものとします。

上記を遵守頂けない場合は、電波法の罰則が適用される可能性があることをご留意ください。日本テキサス・イ

ンスツルメンツ株式会社

東京都新宿区西新宿 6 丁目 2 4 番 1 号

西新宿三井ビル

3.3.3 *Notice for EVMs for Power Line Communication:* Please see [http://www.tij.co.jp/lstds/ti\\_ja/general/eStore/notice\\_02.page](http://www.tij.co.jp/lstds/ti_ja/general/eStore/notice_02.page)

電力線搬送波通信についての開発キットをお使いになる際の注意事項については、次のところをご覧ください。 <https://www.ti.com/ja-jp/legal/notice-for-evaluation-kits-for-power-line-communication.html>

#### 3.4 European Union

3.4.1 *For EVMs subject to EU Directive 2014/30/EU (Electromagnetic Compatibility Directive):*

This is a class A product intended for use in environments other than domestic environments that are connected to a low-voltage power-supply network that supplies buildings used for domestic purposes. In a domestic environment this product may cause radio interference in which case the user may be required to take adequate measures.

- 
4. *EVM Use Restrictions and Warnings:*
    - 4.1 EVMS ARE NOT FOR USE IN FUNCTIONAL SAFETY AND/OR SAFETY CRITICAL EVALUATIONS, INCLUDING BUT NOT LIMITED TO EVALUATIONS OF LIFE SUPPORT APPLICATIONS.
    - 4.2 User must read and apply the user guide and other available documentation provided by TI regarding the EVM prior to handling or using the EVM, including without limitation any warning or restriction notices. The notices contain important safety information related to, for example, temperatures and voltages.
    - 4.3 *Safety-Related Warnings and Restrictions:*
      - 4.3.1 User shall operate the EVM within TI's recommended specifications and environmental considerations stated in the user guide, other available documentation provided by TI, and any other applicable requirements and employ reasonable and customary safeguards. Exceeding the specified performance ratings and specifications (including but not limited to input and output voltage, current, power, and environmental ranges) for the EVM may cause personal injury or death, or property damage. If there are questions concerning performance ratings and specifications, User should contact a TI field representative prior to connecting interface electronics including input power and intended loads. Any loads applied outside of the specified output range may also result in unintended and/or inaccurate operation and/or possible permanent damage to the EVM and/or interface electronics. Please consult the EVM user guide prior to connecting any load to the EVM output. If there is uncertainty as to the load specification, please contact a TI field representative. During normal operation, even with the inputs and outputs kept within the specified allowable ranges, some circuit components may have elevated case temperatures. These components include but are not limited to linear regulators, switching transistors, pass transistors, current sense resistors, and heat sinks, which can be identified using the information in the associated documentation. When working with the EVM, please be aware that the EVM may become very warm.
      - 4.3.2 EVMs are intended solely for use by technically qualified, professional electronics experts who are familiar with the dangers and application risks associated with handling electrical mechanical components, systems, and subsystems. User assumes all responsibility and liability for proper and safe handling and use of the EVM by User or its employees, affiliates, contractors or designees. User assumes all responsibility and liability to ensure that any interfaces (electronic and/or mechanical) between the EVM and any human body are designed with suitable isolation and means to safely limit accessible leakage currents to minimize the risk of electrical shock hazard. User assumes all responsibility and liability for any improper or unsafe handling or use of the EVM by User or its employees, affiliates, contractors or designees.
    - 4.4 User assumes all responsibility and liability to determine whether the EVM is subject to any applicable international, federal, state, or local laws and regulations related to User's handling and use of the EVM and, if applicable, User assumes all responsibility and liability for compliance in all respects with such laws and regulations. User assumes all responsibility and liability for proper disposal and recycling of the EVM consistent with all applicable international, federal, state, and local requirements.
  5. *Accuracy of Information:* To the extent TI provides information on the availability and function of EVMs, TI attempts to be as accurate as possible. However, TI does not warrant the accuracy of EVM descriptions, EVM availability or other information on its websites as accurate, complete, reliable, current, or error-free.
  6. *Disclaimers:*
    - 6.1 EXCEPT AS SET FORTH ABOVE, EVMS AND ANY MATERIALS PROVIDED WITH THE EVM (INCLUDING, BUT NOT LIMITED TO, REFERENCE DESIGNS AND THE DESIGN OF THE EVM ITSELF) ARE PROVIDED "AS IS" AND "WITH ALL FAULTS." TI DISCLAIMS ALL OTHER WARRANTIES, EXPRESS OR IMPLIED, REGARDING SUCH ITEMS, INCLUDING BUT NOT LIMITED TO ANY EPIDEMIC FAILURE WARRANTY OR IMPLIED WARRANTIES OF MERCHANTABILITY OR FITNESS FOR A PARTICULAR PURPOSE OR NON-INFRINGEMENT OF ANY THIRD PARTY PATENTS, COPYRIGHTS, TRADE SECRETS OR OTHER INTELLECTUAL PROPERTY RIGHTS.
    - 6.2 EXCEPT FOR THE LIMITED RIGHT TO USE THE EVM SET FORTH HEREIN, NOTHING IN THESE TERMS SHALL BE CONSTRUED AS GRANTING OR CONFERRING ANY RIGHTS BY LICENSE, PATENT, OR ANY OTHER INDUSTRIAL OR INTELLECTUAL PROPERTY RIGHT OF TI, ITS SUPPLIERS/LICENSORS OR ANY OTHER THIRD PARTY, TO USE THE EVM IN ANY FINISHED END-USER OR READY-TO-USE FINAL PRODUCT, OR FOR ANY INVENTION, DISCOVERY OR IMPROVEMENT, REGARDLESS OF WHEN MADE, CONCEIVED OR ACQUIRED.
  7. *USER'S INDEMNITY OBLIGATIONS AND REPRESENTATIONS.* USER WILL DEFEND, INDEMNIFY AND HOLD TI, ITS LICENSORS AND THEIR REPRESENTATIVES HARMLESS FROM AND AGAINST ANY AND ALL CLAIMS, DAMAGES, LOSSES, EXPENSES, COSTS AND LIABILITIES (COLLECTIVELY, "CLAIMS") ARISING OUT OF OR IN CONNECTION WITH ANY HANDLING OR USE OF THE EVM THAT IS NOT IN ACCORDANCE WITH THESE TERMS. THIS OBLIGATION SHALL APPLY WHETHER CLAIMS ARISE UNDER STATUTE, REGULATION, OR THE LAW OF TORT, CONTRACT OR ANY OTHER LEGAL THEORY, AND EVEN IF THE EVM FAILS TO PERFORM AS DESCRIBED OR EXPECTED.

8. *Limitations on Damages and Liability:*

8.1 *General Limitations.* IN NO EVENT SHALL TI BE LIABLE FOR ANY SPECIAL, COLLATERAL, INDIRECT, PUNITIVE, INCIDENTAL, CONSEQUENTIAL, OR EXEMPLARY DAMAGES IN CONNECTION WITH OR ARISING OUT OF THESE TERMS OR THE USE OF THE EVMS , REGARDLESS OF WHETHER TI HAS BEEN ADVISED OF THE POSSIBILITY OF SUCH DAMAGES. EXCLUDED DAMAGES INCLUDE, BUT ARE NOT LIMITED TO, COST OF REMOVAL OR REINSTALLATION, ANCILLARY COSTS TO THE PROCUREMENT OF SUBSTITUTE GOODS OR SERVICES, RETESTING, OUTSIDE COMPUTER TIME, LABOR COSTS, LOSS OF GOODWILL, LOSS OF PROFITS, LOSS OF SAVINGS, LOSS OF USE, LOSS OF DATA, OR BUSINESS INTERRUPTION. NO CLAIM, SUIT OR ACTION SHALL BE BROUGHT AGAINST TI MORE THAN TWELVE (12) MONTHS AFTER THE EVENT THAT GAVE RISE TO THE CAUSE OF ACTION HAS OCCURRED.

8.2 *Specific Limitations.* IN NO EVENT SHALL TI'S AGGREGATE LIABILITY FROM ANY USE OF AN EVM PROVIDED HEREUNDER, INCLUDING FROM ANY WARRANTY, INDEMNITY OR OTHER OBLIGATION ARISING OUT OF OR IN CONNECTION WITH THESE TERMS, , EXCEED THE TOTAL AMOUNT PAID TO TI BY USER FOR THE PARTICULAR EVM(S) AT ISSUE DURING THE PRIOR TWELVE (12) MONTHS WITH RESPECT TO WHICH LOSSES OR DAMAGES ARE CLAIMED. THE EXISTENCE OF MORE THAN ONE CLAIM SHALL NOT ENLARGE OR EXTEND THIS LIMIT.

9. *Return Policy.* Except as otherwise provided, TI does not offer any refunds, returns, or exchanges. Furthermore, no return of EVM(s) will be accepted if the package has been opened and no return of the EVM(s) will be accepted if they are damaged or otherwise not in a resalable condition. If User feels it has been incorrectly charged for the EVM(s) it ordered or that delivery violates the applicable order, User should contact TI. All refunds will be made in full within thirty (30) working days from the return of the components(s), excluding any postage or packaging costs.

10. *Governing Law:* These terms and conditions shall be governed by and interpreted in accordance with the laws of the State of Texas, without reference to conflict-of-laws principles. User agrees that non-exclusive jurisdiction for any dispute arising out of or relating to these terms and conditions lies within courts located in the State of Texas and consents to venue in Dallas County, Texas. Notwithstanding the foregoing, any judgment may be enforced in any United States or foreign court, and TI may seek injunctive relief in any United States or foreign court.

Mailing Address: Texas Instruments, Post Office Box 655303, Dallas, Texas 75265  
Copyright © 2023, Texas Instruments Incorporated

## IMPORTANT NOTICE AND DISCLAIMER

TI PROVIDES TECHNICAL AND RELIABILITY DATA (INCLUDING DATA SHEETS), DESIGN RESOURCES (INCLUDING REFERENCE DESIGNS), APPLICATION OR OTHER DESIGN ADVICE, WEB TOOLS, SAFETY INFORMATION, AND OTHER RESOURCES "AS IS" AND WITH ALL FAULTS, AND DISCLAIMS ALL WARRANTIES, EXPRESS AND IMPLIED, INCLUDING WITHOUT LIMITATION ANY IMPLIED WARRANTIES OF MERCHANTABILITY, FITNESS FOR A PARTICULAR PURPOSE OR NON-INFRINGEMENT OF THIRD PARTY INTELLECTUAL PROPERTY RIGHTS.

These resources are intended for skilled developers designing with TI products. You are solely responsible for (1) selecting the appropriate TI products for your application, (2) designing, validating and testing your application, and (3) ensuring your application meets applicable standards, and any other safety, security, regulatory or other requirements.

These resources are subject to change without notice. TI grants you permission to use these resources only for development of an application that uses the TI products described in the resource. Other reproduction and display of these resources is prohibited. No license is granted to any other TI intellectual property right or to any third party intellectual property right. TI disclaims responsibility for, and you will fully indemnify TI and its representatives against, any claims, damages, costs, losses, and liabilities arising out of your use of these resources.

TI's products are provided subject to [TI's Terms of Sale](#) or other applicable terms available either on [ti.com](https://www.ti.com) or provided in conjunction with such TI products. TI's provision of these resources does not expand or otherwise alter TI's applicable warranties or warranty disclaimers for TI products.

TI objects to and rejects any additional or different terms you may have proposed.

Mailing Address: Texas Instruments, Post Office Box 655303, Dallas, Texas 75265  
Copyright © 2024, Texas Instruments Incorporated