

LP873327-Q1 Technical Reference Manual

This document provides the register bit values for the one-time programmable (OTP) bits of the orderable part number, LP873327RHDRQ1 / LP873327RHDTQ1.

1 Introduction

This technical reference manual can be used as a reference for the LP873327-Q1 default register bits after OTP memory download. This technical reference manual does not provide information about the electrical characteristics, external components, package, or the functionality of the device. For this information and the full register map, refer to the [LP8733xx-Q1 Dual High-Current Buck Converter and Dual Linear Regulator data sheet](#).

2 OTP Memory Device Settings

This section lists all of the device settings that are downloaded from OTP memory.

[Table 1](#) lists the device settings for I²C and OTP revision ID values.

Table 1. Device Identification and I²C Settings

	Description	Bit Name	LP873327-Q1
I ² C address			0x60
DEVICE_ID	Device specific ID code	DEVICE_ID	0x0
OTP_ID	Identification code for OTP version	OTP_ID	0x27

[Table 2](#) lists the device settings for BUCK0 and BUCK1. The maximum allowed slew-rate for BUCKx depends on the output capacitance. Refer to the [LP8733xx-Q1 Dual High-Current Buck Converter and Dual Linear Regulator data sheet](#) for output capacitance boundary conditions.

Table 2. BUCK0 and BUCK1 OTP Settings

	Description	Bit Name	LP873327-Q1
	Buck phase configuration (2 single phase BUCKs or combined 2 phase, denoted as 1+1 or 2-phase)		1+1
	Switching frequency		2 MHz
	Spread spectrum	EN_SPREAD_SPEC	Enabled
BUCK0	Output voltage	BUCK0_VSET	1.800 V
	Enable, EN-pin or I ² C register	BUCK0_EN_PIN_CTRL	EN-pin
	Control for BUCK0	BUCK0_EN	High
	Force PWM mode or auto mode	BUCK0_FPWM	Force PWM
	Peak current limit	BUCK0_ILIM	4 A
	Maximum load current limit	NA	3 A
	Slew rate	BUCK0_SLEW_RATE	3.8 mV/us
	Startup delay	BUCK0_STARTUP_DELAY	0 ms
Shutdown delay	BUCK0_SHUTDOWN_DELAY	7.5 ms	

Table 2. BUCK0 and BUCK1 OTP Settings (continued)

	Description	Bit Name	LP873327-Q1
BUCK1	Output voltage	BUCK1_VSET	1.115 V
	Enable, EN-pin or I ² C register	BUCK1_EN_PIN_CTRL	EN-pin
	Control for BUCK1	BUCK1_EN	High
	Force PWM mode or auto mode	BUCK1_FPWM	Force PWM
	Peak current limit	BUCK1_ILIM	4 A
	Maximum load current limit	NA	3 A
	Slew rate	BUCK1_SLEW_RATE	1.9 mV/us
	Startup delay	BUCK1_STARTUP_DELAY	10 ms
	Shutdown delay	BUCK1_SHUTDOWN_DELAY	0 ms

Table 3 lists the device settings for LDO0 and LDO1.

Table 3. LDO0 and LDO1 OTP Settings

	Description	Bit Name	LP873327-Q1
LDO0	Output voltage	LDO0_VSET	2.500 V
	Enable, EN-pin or I ² C register	LDO0_EN_PIN_CTRL	EN-pin
	Control for LDO0	LDO0_EN	High
	Startup delay	LDO0_STARTUP_DELAY	10 ms
	Shutdown delay	LDO0_SHUTDOWN_DELAY	0 ms
LDO1	Output voltage	LDO1_VSET	1.800 V
	Enable, EN-pin or I ² C register	LDO1_EN_PIN_CTRL	EN-pin
	Control for LDO1	LDO1_EN	High
	Startup delay	LDO1_STARTUP_DELAY	0 ms
	Shutdown delay	LDO1_SHUTDOWN_DELAY	7.5 ms

Table 4 lists the device settings for GPIOs.

Table 4. EN, CLKIN, and GPIO Pin Settings

	Description	Bit Name	LP873327-Q1
EN pin	EN pin pulldown resistor enable or disable	EN_PD	Enabled
CLKIN pin	CLKIN or GPO2 mode selection	CLKIN_PIN_SEL	CLKIN
	CLKIN pin pulldown resistor enable or disable (applicable for both CLKIN and GPO2 modes.)	CLKIN_PD	Enabled
	Frequency of external clock when connected to CLKIN	EXT_CLK_FREQ	2 MHz
	Enable for the internal PLL. When PLL disabled, internal RC OSC is used	EN_PLL	Enabled
GPO	GPO output type (push-pull or open drain)	GPO_OD	OD
	Enable, EN-pin or I ² C register	GPO_EN_PIN_CTRL	EN-pin
	Control for GPO	GPO_EN	High
	Startup delay	GPO_STARTUP_DELAY	5 ms
	Shutdown delay	GPO_SHUTDOWN_DELAY	2.5 ms
GPO2	GPO2 output type (push-pull or open drain)	GPO2_OD	OD
	Enable, EN-pin or I ² C register	GPO2_EN_PIN_CTRL	EN-pin
	Control for GPO2	GPO2_EN	High
	Startup delay	GPO2_STARTUP_DELAY	0 ms
	Shutdown delay	GPO2_SHUTDOWN_DELAY	0 ms

Table 5 lists the device PGOOD settings.

Table 5. PGOOD OTP Settings

	Description	Bit Name	LP873327-Q1
Signals monitored by PGOOD	BUCK0 output voltage	EN_PGOOD_BUCK0	Yes
	BUCK1 output voltage	EN_PGOOD_BUCK1	Yes
	LDO0 output voltage	EN_PGOOD_LDO0	Yes
	LDO1 output voltage	EN_PGOOD_LDO1	Yes
	Thermal warning	EN_PGOOD_TWARN	No
PGOOD mode selections	PGOOD thresholds for BUCK0, BUCK1 (Undervoltage and Window (undervoltage and overvoltage))	PGOOD_WINDOW_BUCK	Window
	PGOOD thresholds for LDO0, LDO1 (Undervoltage and Window (undervoltage and overvoltage))	PGOOD_WINDOW_LDO	Window
	PGOOD operating mode (detecting UNUSUAL situations or detecting UNVALID situations)	PGOOD_MODE	Detecting UNUSUAL situations
	PGOOD signal mode (status or latched until fault source read)	PG_FAULT_GATES_PGOOD	Status
	PGOOD output mode (push-pull or open drain)	PGOOD_OD	OD
	PGOOD polarity (active high or active low)	PGOOD_POL	Active High

Table 6 lists the device protection settings.

Table 6. Protections OTP Settings

	Description	Bit Name	LP873327-Q1
Protections	Thermal warning level (125°C or 137°C)	TDIE_WARN_LEVEL	140°C
	Input overvoltage protection	NA	Enabled

Table 7 lists the device settings for interrupts. When an interrupt from an event is unmasked, an interrupt is generated on the nINT pin.

Table 7. Interrupt Mask Settings

	Interrupt event	Bit Name	LP873327-Q1
General	PGOOD pin changing active to inactive	PGOOD_INT_MASK	Masked
	Sync clock appears or disappears	SYNC_CLK_MASK	Masked
	Thermal warning	TDIE_WRN_MASK	Unmasked
	Load measurement ready	I_MEAS_MASK	Masked
	Register reset	RESET_REG_MASK	Masked
BUCK0	Buck0 PGood active	BUCK0_PGR_MASK	Masked
	Buck0 PGood inactive	BUCK0_PGF_MASK	Masked
	Buck0 current limit	BUCK0_ILIM_MASK	Masked
BUCK1	Buck1 PGood active	BUCK1_PGR_MASK	Masked
	Buck1 PGood inactive	BUCK1_PGF_MASK	Masked
	Buck1 current limit	BUCK1_ILIM_MASK	Masked
LDO0	LDO0 PGood active	LDO0_PGR_MASK	Masked
	LDO0 PGood inactive	LDO0_PGF_MASK	Masked
	LDO0 current limit	LDO0_ILIM_MASK	Masked
LDO1	LDO1 PGood active	LDO1_PGR_MASK	Masked
	LDO1 PGood inactive	LDO1_PGF_MASK	Masked
	LDO1 current limit	LDO1_ILIM_MASK	Masked

3 Power-up and Power Down Sequence

This section shows the power-up and power-down sequence for the device. The power-up and power-down delays for each rail are shown in [Section 2](#).

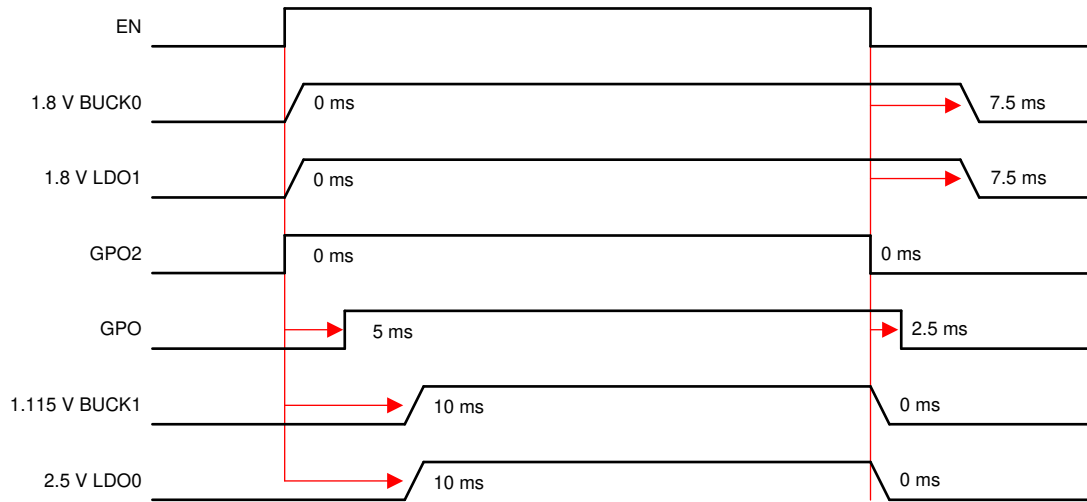

Figure 1. LP873327-Q1 Power-up and Power Down Sequence

4 Register Bits Loaded From OTP Memory

Table 8 lists the register bit values loaded from the OTP memory during device start-up.

Table 8. Summary of Control Registers

Address	Register Name	Bit	LP873327-Q1 Value
0x00	DEV_REV	DEVICE_ID[1:0]	0x0
0x01	OTP_REV	OTP_ID[7:0]	0x27
0x02	BUCK0_CTRL_1	BUCK0_FPWM	0x1
0x02	BUCK0_CTRL_1	BUCK0_EN_PIN_CTRL	0x1
0x02	BUCK0_CTRL_1	BUCK0_EN	0x1
0x03	BUCK0_CTRL_2	BUCK0_ILIM[2:0]	0x5
0x03	BUCK0_CTRL_2	BUCK0_SLEW_RATE[2:0]	0x4
0x04	BUCK1_CTRL_1	BUCK1_FPWM	0x1
0x04	BUCK1_CTRL_1	BUCK1_EN_PIN_CTRL	0x1
0x04	BUCK1_CTRL_1	BUCK1_EN	0x1
0x05	BUCK1_CTRL_2	BUCK1_ILIM[2:0]	0x5
0x05	BUCK1_CTRL_2	BUCK1_SLEW_RATE[2:0]	0x5
0x06	BUCK0_VOUT	BUCK0_VSET[7:0]	0xB1
0x07	BUCK1_VOUT	BUCK1_VSET[7:0]	0x64
0x08	LDO0_CTRL	LDO0_EN_PIN_CTRL	0x1
0x08	LDO0_CTRL	LDO0_EN	0x1
0x09	LDO1_CTRL	LDO1_EN_PIN_CTRL	0x1
0x09	LDO1_CTRL	LDO1_EN	0x1
0x0A	LDO0_VOUT	LDO0_VSET[4:0]	0x11
0x0B	LDO1_VOUT	LDO1_VSET[4:0]	0xA
0x0C	BUCK0_DELAY	BUCK0_SHUTDOWN_DELAY[3:0]	0xF
0x0C	BUCK0_DELAY	BUCK0_STARTUP_DELAY[3:0]	0x0
0x0D	BUCK1_DELAY	BUCK1_SHUTDOWN_DELAY[3:0]	0x0
0x0D	BUCK1_DELAY	BUCK1_STARTUP_DELAY[3:0]	0xA
0x0E	LDO0_DELAY	LDO0_SHUTDOWN_DELAY[3:0]	0x0
0x0E	LDO0_DELAY	LDO0_STARTUP_DELAY[3:0]	0xA
0x0F	LDO1_DELAY	LDO1_SHUTDOWN_DELAY[3:0]	0xF
0x0F	LDO1_DELAY	LDO1_STARTUP_DELAY[3:0]	0x0
0x10	GPO_DELAY	GPO_SHUTDOWN_DELAY[3:0]	0x5
0x10	GPO_DELAY	GPO_STARTUP_DELAY[3:0]	0x5
0x11	GPO2_DELAY	GPO2_SHUTDOWN_DELAY[3:0]	0x0
0x11	GPO2_DELAY	GPO2_STARTUP_DELAY[3:0]	0x0
0x12	GPO_CTRL	GPO2_OD	0x1
0x12	GPO_CTRL	GPO2_EN_PIN_CTRL	0x1
0x12	GPO_CTRL	GPO2_EN	0x1
0x12	GPO_CTRL	GPO_OD	0x1
0x12	GPO_CTRL	GPO_EN_PIN_CTRL	0x1
0x12	GPO_CTRL	GPO_EN	0x1
0x13	CONFIG	STARTUP_DELAY_SEL	0x1
0x13	CONFIG	SHUTDOWN_DELAY_SEL	0x0
0x13	CONFIG	CLKIN_PIN_SEL	0x1
0x13	CONFIG	CLKIN_PD	0x1
0x13	CONFIG	EN_PD	0x1
0x13	CONFIG	TDIE_WARN_LEVEL	0x1
0x13	CONFIG	EN_SPREAD_SPEC	0x1
0x14	PLL_CTRL	EN_PLL	0x1
0x14	PLL_CTRL	EXT_CLK_FREQ[4:0]	0x1
0x15	PGOOD_CTRL_1	PGOOD_POL	0x0

Table 8. Summary of Control Registers (continued)

Address	Register Name	Bit	LP873327-Q1 Value
0x15	PGOOD_CTRL_1	PGOOD_OD	0x1
0x15	PGOOD_CTRL_1	PGOOD_WINDOW_LDO	0x1
0x15	PGOOD_CTRL_1	PGOOD_WINDOW_BUCK	0x1
0x15	PGOOD_CTRL_1	EN_PGOOD_LDO1	0x1
0x15	PGOOD_CTRL_1	EN_PGOOD_LDO0	0x1
0x15	PGOOD_CTRL_1	EN_PGOOD_BUCK1	0x1
0x15	PGOOD_CTRL_1	EN_PGOOD_BUCK0	0x1
0x16	PGOOD_CTRL_2	EN_PGOOD_TWARN	0x0
0x16	PGOOD_CTRL_2	PG_FAULT_GATES_PGOOD	0x0
0x16	PGOOD_CTRL_2	PGOOD_MODE	0x0
0x20	TOP_MASK_1	PGOOD_INT_MASK	0x1
0x20	TOP_MASK_1	SYNC_CLK_MASK	0x1
0x20	TOP_MASK_1	TDIE_WARN_MASK	0x0
0x20	TOP_MASK_1	I_MEAS_MASK	0x1
0x21	TOP_MASK_2	RESET_REG_MASK	0x1
0x22	BUCK_MASK	BUCK1_PGF_MASK	0x1
0x22	BUCK_MASK	BUCK1_PGR_MASK	0x1
0x22	BUCK_MASK	BUCK1_ILIM_MASK	0x1
0x22	BUCK_MASK	BUCK0_PGF_MASK	0x1
0x22	BUCK_MASK	BUCK0_PGR_MASK	0x1
0x22	BUCK_MASK	BUCK0_ILIM_MASK	0x1
0x23	LDO_MASK	LDO1_PGF_MASK	0x1
0x23	LDO_MASK	LDO1_PGR_MASK	0x1
0x23	LDO_MASK	LDO1_ILIM_MASK	0x1
0x23	LDO_MASK	LDO0_PGF_MASK	0x1
0x23	LDO_MASK	LDO0_PGR_MASK	0x1
0x23	LDO_MASK	LDO0_ILIM_MASK	0x1

Mechanical, Packaging, and Orderable Information

The following pages include mechanical, packaging, and orderable information. This information is the most current data available for the designated devices. This data is subject to change without notice and revision of this document. For browser-based versions of this data sheet, refer to the left-hand navigation.

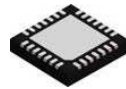

RHD0028W

PACKAGE OUTLINE

VQFN - 1 mm max height

PLASTIC QUAD FLATPACK - NO LEAD

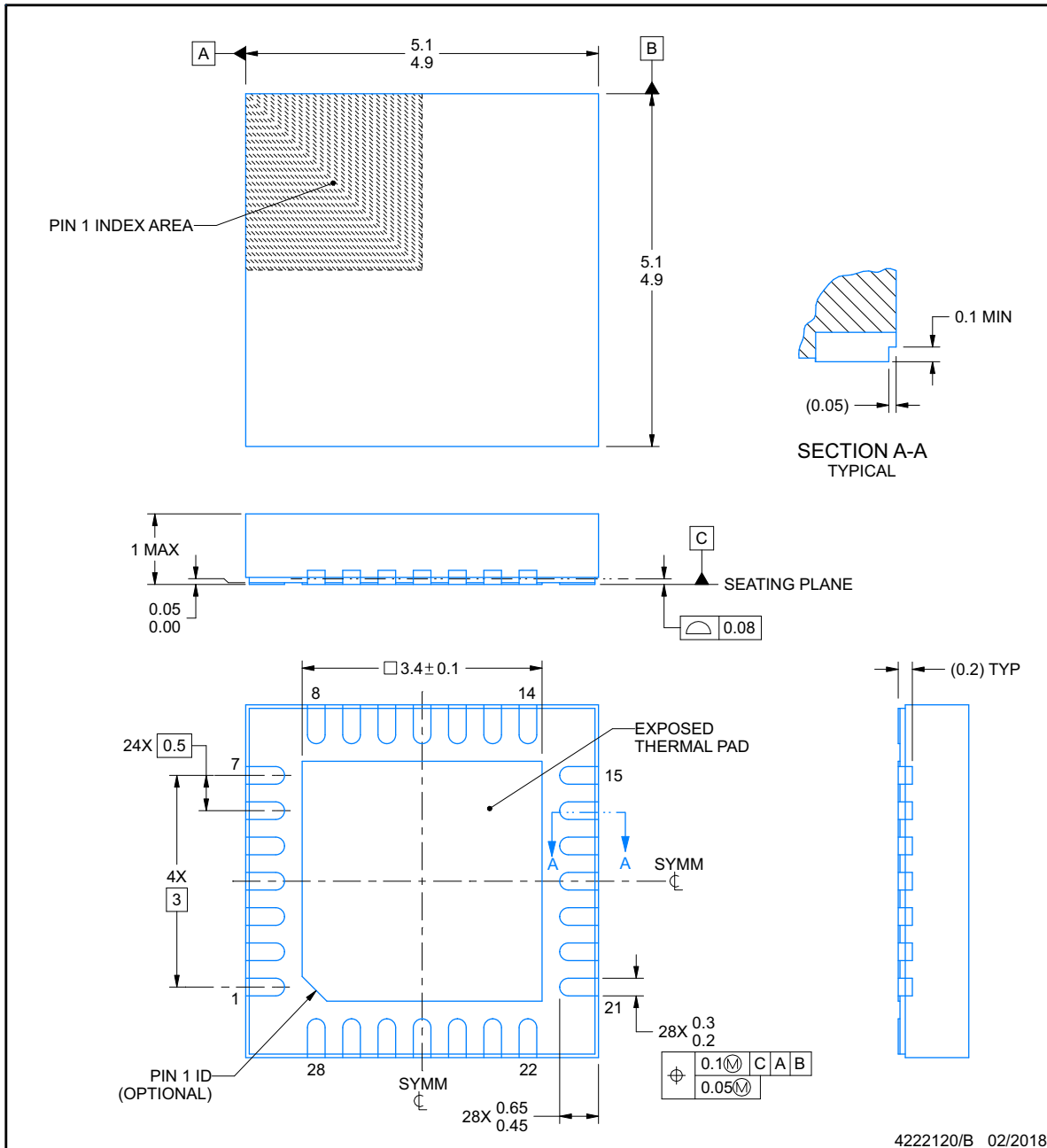

NOTES:

1. All linear dimensions are in millimeters. Any dimensions in parenthesis are for reference only. Dimensioning and tolerancing per ASME Y14.5M.
2. This drawing is subject to change without notice.
3. The package thermal pad must be soldered to the printed circuit board for thermal and mechanical performance.

EXAMPLE BOARD LAYOUT

RHD0028W

VQFN - 1 mm max height

PLASTIC QUAD FLATPACK - NO LEAD

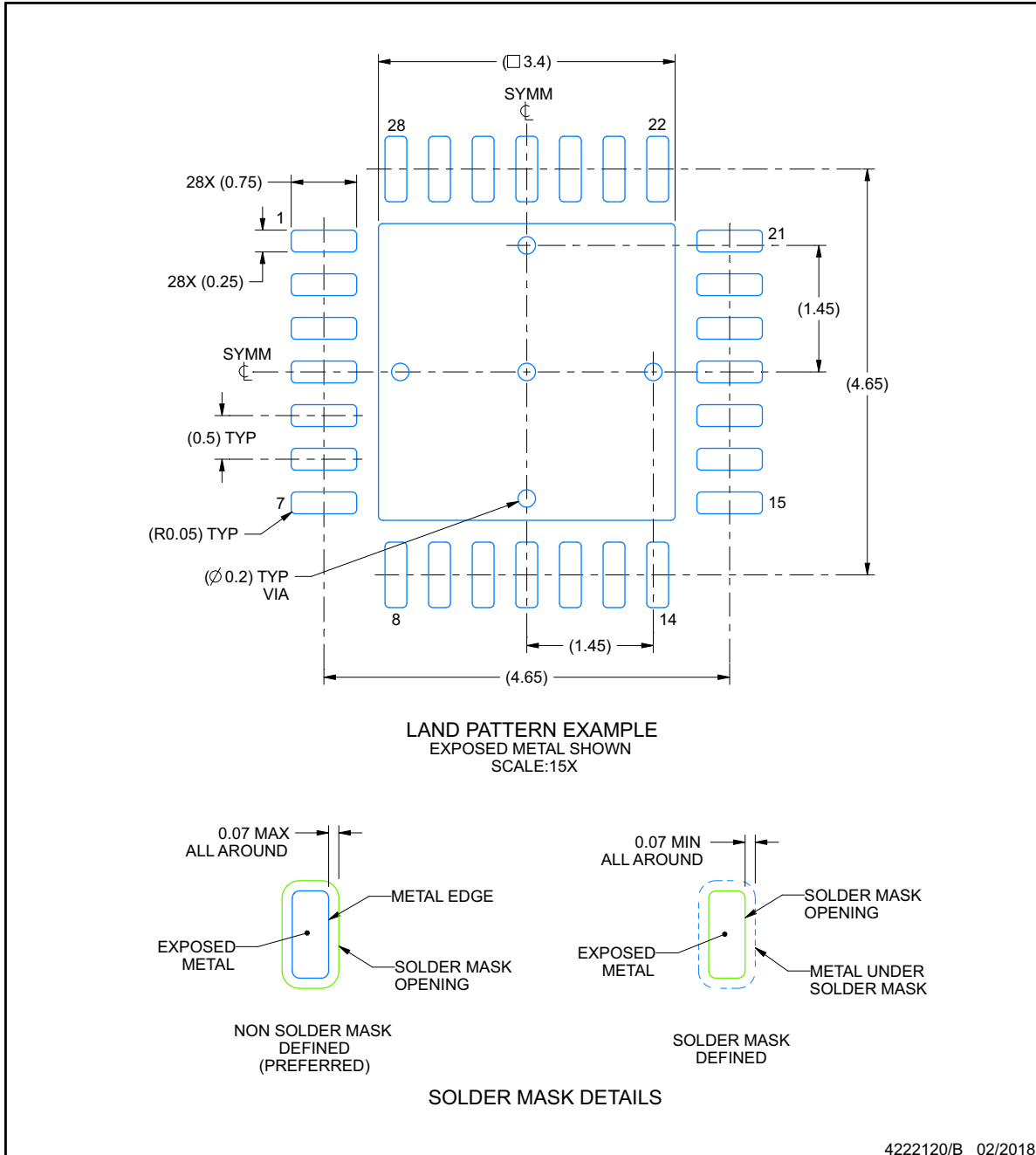

NOTES: (continued)

4. This package is designed to be soldered to a thermal pad on the board. For more information, see Texas Instruments literature number SLUA271 (www.ti.com/lit/slua271).

EXAMPLE STENCIL DESIGN

RHD0028W

VQFN - 1 mm max height

PLASTIC QUAD FLATPACK - NO LEAD

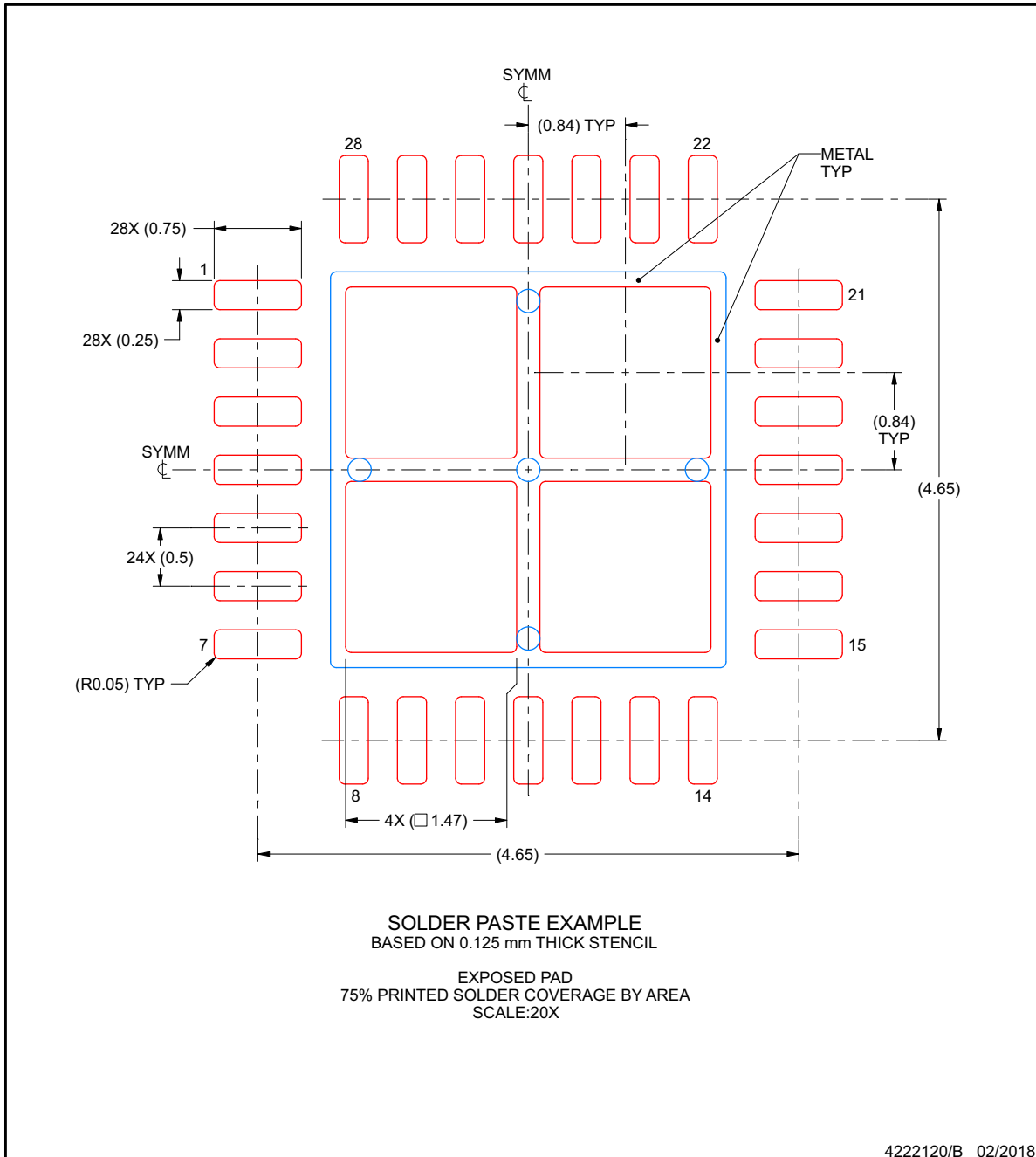

NOTES: (continued)

5. Laser cutting apertures with trapezoidal walls and rounded corners may offer better paste release. IPC-7525 may have alternate design recommendations.

1 Packaging Information

Orderable Device	Status ⁽¹⁾	Package Type	Package Drawing	Pins	Package Qty	Eco Plan ⁽²⁾	Lead/Ball Finish ⁽³⁾	MSL Peak Temp ⁽⁴⁾	Op Temp (°C)	Device Marking ⁽⁵⁾⁽⁶⁾
LP873327RHDRQ1	ACTIVE	VQFN	RHD	28	3000	Green (RoHS & no Sb/Br)	CU SN	Level-2-260C-1 YEAR	-40 to 125	LP8733 27RHDRQ1
LP873327RHDTQ1	ACTIVE	VQFN	RHD	28	250	Green (RoHS & no Sb/Br)	CU SN	Level-2-260C-1 YEAR	-40 to 125	LP8733 27RHDTQ1

- ⁽¹⁾ The marketing status values are defined as follows:
ACTIVE: Product device recommended for new designs.
LIFEBUY: TI has announced that the device will be discontinued, and a lifetime-buy period is in effect.
NRND: Not recommended for new designs. Device is in production to support existing customers, but TI does not recommend using this part in a new design.
PRE_PROD Unannounced device, not in production, not available for mass market, nor on the web, samples not available.
PREVIEW: Device has been announced but is not in production. Samples may or may not be available.
OBSOLETE: TI has discontinued the production of the device.
- ⁽²⁾ Eco Plan - The planned eco-friendly classification: Pb-Free (RoHS), Pb-Free (RoHS Exempt), or Green (RoHS & no Sb/Br) - please check <http://www.ti.com/productcontent> for the latest availability information and additional product content details.
TBD: The Pb-Free/Green conversion plan has not been defined.
Pb-Free (RoHS): TI's terms "Lead-Free" or "Pb-Free" mean semiconductor products that are compatible with the current RoHS requirements for all 6 substances, including the requirement that lead not exceed 0.1% by weight in homogeneous materials. Where designed to be soldered at high temperatures, TI Pb-Free products are suitable for use in specified lead-free processes.
Pb-Free (RoHS Exempt): This component has a RoHS exemption for either 1) lead-based flip-chip solder bumps used between the die and package, or 2) lead-based die adhesive used between the die and leadframe. The component is otherwise considered Pb-Free (RoHS compatible) as defined above.
Green (RoHS & no Sb/Br): TI defines "Green" to mean Pb-Free (RoHS compatible), and free of Bromine (Br) and Antimony (Sb) based flame retardants (Br or Sb do not exceed 0.1% by weight in homogeneous material)
- ⁽³⁾ Lead/Ball Finish - Orderable Devices may have multiple material finish options. Finish options are separated by a vertical ruled line. Lead/Ball Finish values may wrap to two lines if the finish value exceeds the maximum column width.
- ⁽⁴⁾ MSL, Peak Temp. -- The Moisture Sensitivity Level rating according to the JEDEC industry standard classifications, and peak solder temperature.
- ⁽⁵⁾ There may be additional marking, which relates to the logo, the lot trace code information, or the environmental category on the device
- ⁽⁶⁾ Multiple Device markings will be inside parentheses. Only one Device Marking contained in parentheses and separated by a "~" will appear on a device. If a line is indented then it is a continuation of the previous line and the two combined represent the entire Device Marking for that device.

Important Information and Disclaimer: The information provided on this page represents TI's knowledge and belief as of the date that it is provided. TI bases its knowledge and belief on information provided by third parties, and makes no representation or warranty as to the accuracy of such information. Efforts are underway to better integrate information from third parties. TI has taken and continues to take reasonable steps to provide representative and accurate information but may not have conducted destructive testing or chemical analysis on incoming materials and chemicals. TI and TI suppliers consider certain information to be proprietary, and thus CAS numbers and other limited information may not be available for release.

In no event shall TI's liability arising out of such information exceed the total purchase price of the TI part(s) at issue in this document sold by TI to Customer on an annual basis.

1.1 Tape and Reel Information

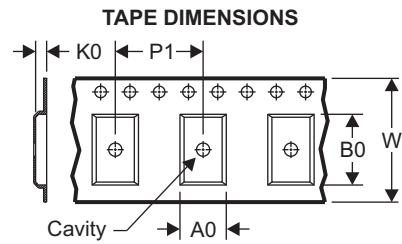
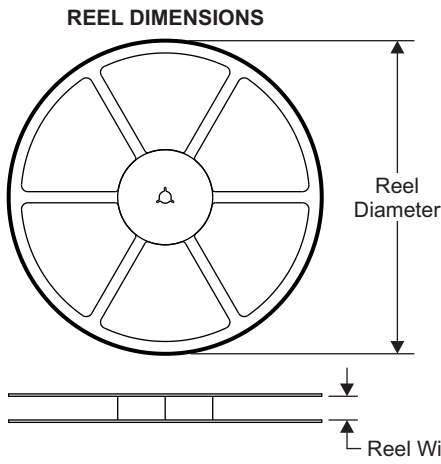

A0	Dimension designed to accommodate the component width
B0	Dimension designed to accommodate the component length
K0	Dimension designed to accommodate the component thickness
W	Overall width of the carrier tape
P1	Pitch between successive cavity centers

QUADRANT ASSIGNMENTS FOR PIN 1 ORIENTATION IN TAPE

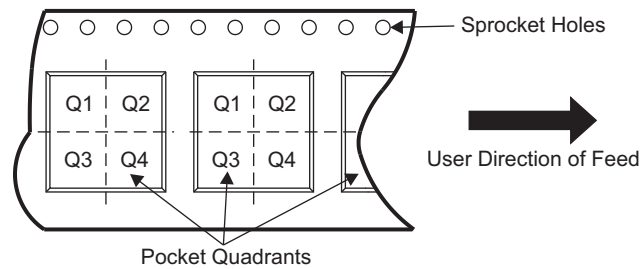

Device	Package Type	Package Drawing	Pins	SPQ	Reel Diameter (mm)	Reel Width W1 (mm)	A0 (mm)	B0 (mm)	K0 (mm)	P1 (mm)	W (mm)	Pin1 Quadrant
LP873327RHDRQ1	VQFN	RHD	28	3000	330.0	12.4	5.25	5.25	1.1	8.0	12.0	Q2
LP873327RHDTQ1	VQFN	RHD	28	250	330.0	12.4	5.25	5.25	1.1	8.0	12.0	Q2

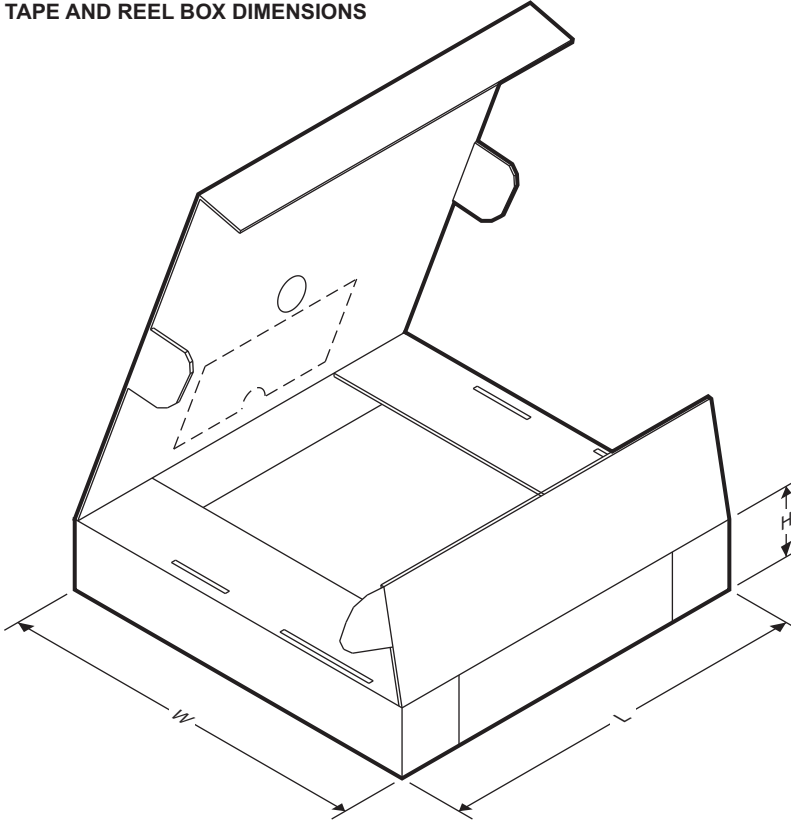
TAPE AND REEL BOX DIMENSIONS

Device	Package Type	Package Drawing	Pins	SPQ	Length (mm)	Width (mm)	Height (mm)
LP873327RHDRQ1	VQFN	RHD	28	3000	370.0	355.0	55.0
LP873327RHDTQ1	VQFN	RHD	28	250	370.0	355.0	55.0

IMPORTANT NOTICE AND DISCLAIMER

TI PROVIDES TECHNICAL AND RELIABILITY DATA (INCLUDING DATASHEETS), DESIGN RESOURCES (INCLUDING REFERENCE DESIGNS), APPLICATION OR OTHER DESIGN ADVICE, WEB TOOLS, SAFETY INFORMATION, AND OTHER RESOURCES "AS IS" AND WITH ALL FAULTS, AND DISCLAIMS ALL WARRANTIES, EXPRESS AND IMPLIED, INCLUDING WITHOUT LIMITATION ANY IMPLIED WARRANTIES OF MERCHANTABILITY, FITNESS FOR A PARTICULAR PURPOSE OR NON-INFRINGEMENT OF THIRD PARTY INTELLECTUAL PROPERTY RIGHTS.

These resources are intended for skilled developers designing with TI products. You are solely responsible for (1) selecting the appropriate TI products for your application, (2) designing, validating and testing your application, and (3) ensuring your application meets applicable standards, and any other safety, security, or other requirements. These resources are subject to change without notice. TI grants you permission to use these resources only for development of an application that uses the TI products described in the resource. Other reproduction and display of these resources is prohibited. No license is granted to any other TI intellectual property right or to any third party intellectual property right. TI disclaims responsibility for, and you will fully indemnify TI and its representatives against, any claims, damages, costs, losses, and liabilities arising out of your use of these resources.

TI's products are provided subject to TI's Terms of Sale (www.ti.com/legal/termsofsale.html) or other applicable terms available either on ti.com or provided in conjunction with such TI products. TI's provision of these resources does not expand or otherwise alter TI's applicable warranties or warranty disclaimers for TI products.

Mailing Address: Texas Instruments, Post Office Box 655303, Dallas, Texas 75265
Copyright © 2020, Texas Instruments Incorporated