

AFE5832LP 32-Channel Ultrasound AFE With 18.5-mW/Channel Power, 4-nV/√Hz, 12-Bit, 40-MSPS or 10-Bit, 50-MSPS Output and Passive CW Mixer

1 Features

- 32-Channel AFE for Ultrasound Applications:
 - LNA, Attenuator, LPF, ADC, and CW Mixer
 - Digital Time Gain Compensation (DTGC)
 - Total Gain Range: 0 dB to 48 dB
- Low-Noise Amplifier (LNA) With Programmable Gain:
 - Low Current Noise of 1pA/rtHz
 - Gain: 21 dB, 18 dB, and 15 dB
 - Linear Input Range: up to 700 mV_{PP}
- Programmable Attenuator (ATTEN):
 - Attenuation Range (Steps of 0.125 dB): 0 to 36 dB
 - Digital TGC Engine
- Programmable Gain Amplifier (PGA):
 - Gain: 21 dB, 24 dB, and 27 dB
- Third-Order, Linear-Phase, Low-Pass Filter (LPF):
 - Cut-off Frequency From 10 MHz to 25 MHz
- 16 ADCs Converting at 12-Bit, 80 MSPS or 10-Bit, 100 MSPS:
 - Each ADC Converts Two Sets of Inputs at Half Rate
 - 12-Bit Mode: 72-dBFS SNR
 - 10-Bit Mode: 61-dBFS SNR
- TGC Mode Power :
 - Lowest Power of 18.5 mW/Ch in Low Power Mode, 4 nV/rtHz, 10-Bit, 20 MSPS, LVDS (2x rate)
 - 27.8 mW/Ch at 3 nV/rtHz in Low Noise Mode at 12-Bit, 40 MSPS
 - 24.4 mW/Ch at 4 nV/rtHz in Low Power Mode

at 12-Bit, 40 MSPS

- Excellent Device-to-Device Gain Matching:
 - ±0.5 dB (Typical)
- Harmonic Distortion: –55 dBc level
- Fast and Consistent Overload Recovery
- Continuous Wave (CW) Path With:
 - Low Close-In Phase Noise of –148 dBc/Hz at 1-kHz Frequency Offset off 5-MHz Carrier
 - Power Consumption With No Signal: 10 mW/Ch
 - Phase Resolution: λ/16
 - 12-dB Suppression on Third and Fifth Harmonics
- LVDS Interface with a Speed Up to 1-Gbps
- Small Package: 15-mm × 15-mm NFBGA-289

2 Applications

- Medical Ultrasound Imaging
- Nondestructive Evaluation Equipment
- Sonar Imaging Equipment
- In-Probe Electronics

3 Description

The AFE5832LP is a highly integrated, analog front-end (AFE) solution specifically designed for portable ultrasound systems where high performance, low power, and small size are required.

Device Information⁽¹⁾

PART NUMBER	PACKAGE	BODY SIZE (NOM)
AFE5832LP	nFBGA (289)	15.00 mm × 15.00 mm

(1) For all available packages, see the orderable addendum at the end of the data sheet.

Simplified Block Diagram

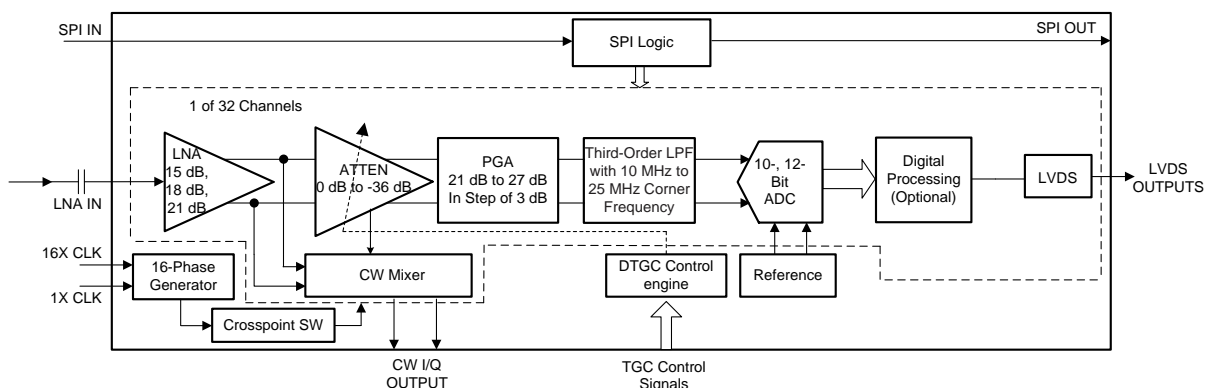

Table of Contents

1 Features	1	6.2 Receiving Notification of Documentation Updates....	4
2 Applications	1	6.3 Community Resources.....	4
3 Description	1	6.4 Trademarks	4
4 Revision History	2	6.5 Electrostatic Discharge Caution.....	4
5 Description (continued)	3	6.6 Glossary	4
6 Device and Documentation Support	4	7 Mechanical, Packaging, and Orderable Information	5
6.1 Documentation Support	4		

4 Revision History

NOTE: Page numbers for previous revisions may differ from page numbers in the current version.

DATE	REVISION	NOTES
December 2018	*	Initial release

5 Description (continued)

The device is realized through a multichip module (MCM) with two dies: 1 VCA die and 1 ADC die. The VCA die has 32 channels that interface with the 16 channels of the ADC die. Each ADC channel alternately converts an odd and an even VCA channel.

Each channel in the VCA die can be configured in either of two modes: time-gain-compensation (TGC) mode or continuous wave (CW) mode. In the TGC mode, each channel includes a low-noise amplifier (LNA), a programmable attenuator (ATTEN), a programmable gain amplifier and a third-order, low-pass filter (LPF). The LNA gain is programmable to 21 dB, 18 dB, or 15 dB. The ATTEN supports an attenuation range of 0 dB to 36 dB, with digital control for the attenuation. The PGA provides gain options from 21 dB to 27 dB in steps of 3 dB. The LPF cutoff frequency can be set between 10 MHz and 25 MHz to support ultrasound applications with different frequencies. In the CW mode, the output of the LNA goes to a low-power passive mixer with 16 selectable phase delays. Different phase delays can be applied to each analog input signal to perform an on-chip beamforming operation. A harmonic filter in the CW mixer suppresses the third and fifth harmonic to enhance the sensitivity of the CW Doppler measurement.

The 16 channels of the ADC die can be configured to operate with a resolution of 12 bits or 10 bits. The ADC resolution can be traded off with conversion rate and can operate at maximum speeds of 80 MSPS and 100 MSPS at 12-bit and 10-bit resolution, respectively. Because each ADC alternately converts two VCA channels, the resulting maximum sample rate of each of the 32 channels of the AFE is 40 MSPS and 50 MSPS in the 12-bit and 10-bit modes, respectively. The ADC is designed to scale its power with sampling rate. The output interface of the ADC comes out through a low-voltage differential signaling (LVDS), which can easily interface with low-cost field-programmable gate arrays (FPGAs).

A very low-power AFE solution makes it suitable for system with strict battery-life requirement.

The AFE is available in a 15 mm × 15 mm 289-pin NFBGA package and is pin-compatible with the AFE5832 family.

6 Device and Documentation Support

6.1 Documentation Support

6.1.1 Related Documentation

For related documentation see the following:

- [AFE5818 16-Channel, Ultrasound, Analog Front-End with 140-mW/Channel Power, 0.75-nV/√Hz Noise, 14-Bit, 65-MSPS or 12-Bit, 80-MSPS ADC, and Passive CW Mixer](#)
- [ADS8413 16-BIT, 2-MSPS, LVDS SERIAL INTERFACE, SAR ANALOG-TO-DIGITAL CONVERTER](#)
- [ADS8472 16-BIT, 1-MSPS, PSEUDO-BIPOLAR, FULLY DIFFERENTIAL INPUT, MICROPOWER SAMPLING ANALOG-TO-DIGITAL CONVERTER WITH PARALLEL INTERFACE, REFERENCE](#)
- [CDCE72010 Ten Output High Performance Clock Synchronizer, Jitter Cleaner, and Clock Distributor](#)
- [CDCM7005 3.3-V High Performance Clock Synchronizer and Jitter Cleaner](#)
- [ISO724x High-Speed, Quad-Channel Digital Isolators](#)
- [LMK0480x Low-Noise Clock Jitter Cleaner with Dual Loop PLLs](#)
- [OPA1632 High-Performance, Fully-Differential Audio Operational Amplifier](#)
- [OPA2x11 1.1-nV/√Hz Noise, Low Power, Precision Operational Amplifier](#)
- [SN74AUP1T04 LOW POWER, 1.8/2.5/3.3-V INPUT, 3.3-V CMOS OUTPUT, SINGLE INVERTER GATE](#)
- [THS413x High-Speed, Low-Noise, Fully-Differential I/O Amplifiers](#)
- [MicroStar BGA Packaging Reference Guide](#)

6.2 Receiving Notification of Documentation Updates

To receive notification of documentation updates, navigate to the device product folder on ti.com. In the upper right corner, click on *Alert me* to register and receive a weekly digest of any product information that has changed. For change details, review the revision history included in any revised document.

6.3 Community Resources

The following links connect to TI community resources. Linked contents are provided "AS IS" by the respective contributors. They do not constitute TI specifications and do not necessarily reflect TI's views; see TI's [Terms of Use](#).

TI E2E™ Online Community *TI's Engineer-to-Engineer (E2E) Community*. Created to foster collaboration among engineers. At e2e.ti.com, you can ask questions, share knowledge, explore ideas and help solve problems with fellow engineers.

Design Support *TI's Design Support* Quickly find helpful E2E forums along with design support tools and contact information for technical support.

6.4 Trademarks

E2E is a trademark of Texas Instruments. All other trademarks are the property of their respective owners.

6.5 Electrostatic Discharge Caution



This integrated circuit can be damaged by ESD. Texas Instruments recommends that all integrated circuits be handled with appropriate precautions. Failure to observe proper handling and installation procedures can cause damage.

ESD damage can range from subtle performance degradation to complete device failure. Precision integrated circuits may be more susceptible to damage because very small parametric changes could cause the device not to meet its published specifications.

6.6 Glossary

SLYZ022 — *TI Glossary*.

This glossary lists and explains terms, acronyms, and definitions.

7 Mechanical, Packaging, and Orderable Information

The following pages include mechanical, packaging, and orderable information. This information is the most current data available for the designated devices. This data is subject to change without notice and revision of this document. For browser-based versions of this data sheet, refer to the left-hand navigation.

PACKAGING INFORMATION

Orderable Device	Status (1)	Package Type	Package Drawing	Pins	Package Qty	Eco Plan (2)	Lead finish/ Ball material (6)	MSL Peak Temp (3)	Op Temp (°C)	Device Marking (4/5)	Samples
AFE5832LPZAV	ACTIVE	NFBGA	ZAV	289	126	RoHS & Green	SNAGCU	Level-3-260C-168 HR	0 to 85	AFE5832LP	Samples

(1) The marketing status values are defined as follows:

ACTIVE: Product device recommended for new designs.

LIFEBUY: TI has announced that the device will be discontinued, and a lifetime-buy period is in effect.

NRND: Not recommended for new designs. Device is in production to support existing customers, but TI does not recommend using this part in a new design.

PREVIEW: Device has been announced but is not in production. Samples may or may not be available.

OBSOLETE: TI has discontinued the production of the device.

(2) **RoHS:** TI defines "RoHS" to mean semiconductor products that are compliant with the current EU RoHS requirements for all 10 RoHS substances, including the requirement that RoHS substance do not exceed 0.1% by weight in homogeneous materials. Where designed to be soldered at high temperatures, "RoHS" products are suitable for use in specified lead-free processes. TI may reference these types of products as "Pb-Free".

RoHS Exempt: TI defines "RoHS Exempt" to mean products that contain lead but are compliant with EU RoHS pursuant to a specific EU RoHS exemption.

Green: TI defines "Green" to mean the content of Chlorine (Cl) and Bromine (Br) based flame retardants meet JS709B low halogen requirements of <=1000ppm threshold. Antimony trioxide based flame retardants must also meet the <=1000ppm threshold requirement.

(3) MSL, Peak Temp. - The Moisture Sensitivity Level rating according to the JEDEC industry standard classifications, and peak solder temperature.

(4) There may be additional marking, which relates to the logo, the lot trace code information, or the environmental category on the device.

(5) Multiple Device Markings will be inside parentheses. Only one Device Marking contained in parentheses and separated by a "-" will appear on a device. If a line is indented then it is a continuation of the previous line and the two combined represent the entire Device Marking for that device.

(6) Lead finish/Ball material - Orderable Devices may have multiple material finish options. Finish options are separated by a vertical ruled line. Lead finish/Ball material values may wrap to two lines if the finish value exceeds the maximum column width.

Important Information and Disclaimer:The information provided on this page represents TI's knowledge and belief as of the date that it is provided. TI bases its knowledge and belief on information provided by third parties, and makes no representation or warranty as to the accuracy of such information. Efforts are underway to better integrate information from third parties. TI has taken and continues to take reasonable steps to provide representative and accurate information but may not have conducted destructive testing or chemical analysis on incoming materials and chemicals. TI and TI suppliers consider certain information to be proprietary, and thus CAS numbers and other limited information may not be available for release.

In no event shall TI's liability arising out of such information exceed the total purchase price of the TI part(s) at issue in this document sold by TI to Customer on an annual basis.

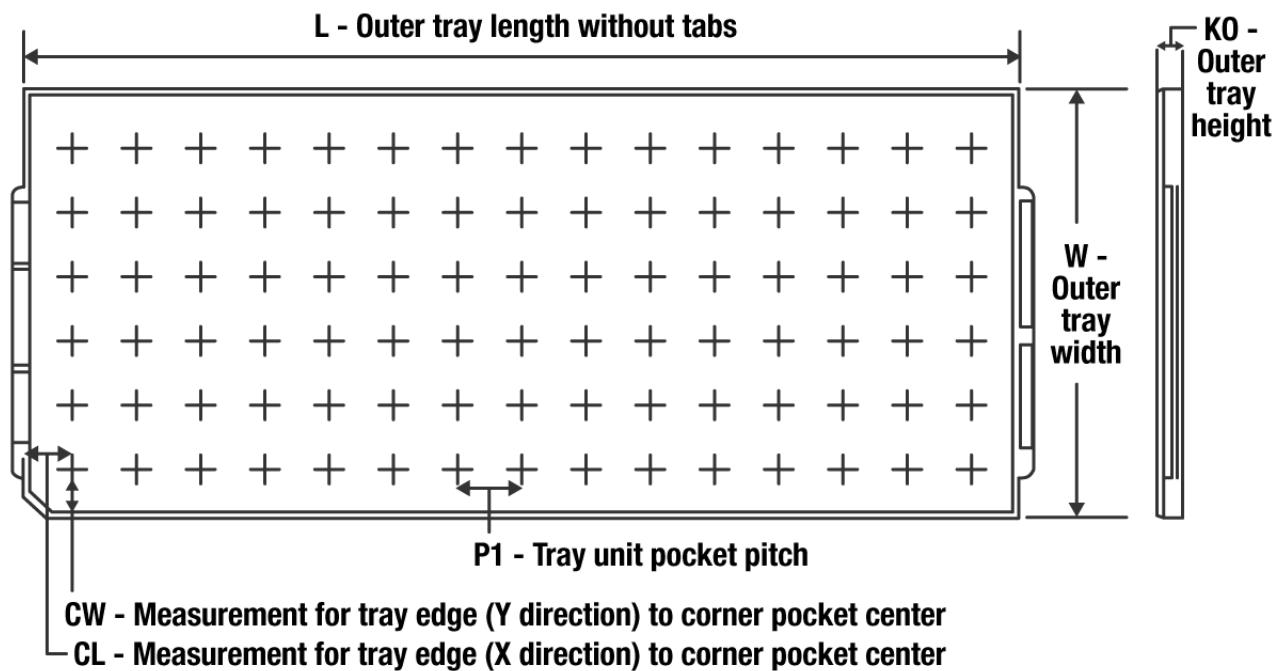
TRAY

Chamfer on Tray corner indicates Pin 1 orientation of packed units.

*All dimensions are nominal

Device	Package Name	Package Type	Pins	SPQ	Unit array matrix	Max temperature (°C)	L (mm)	W (mm)	K0 (µm)	P1 (mm)	CL (mm)	CW (mm)
AFE5832LPZAV	ZAV	NFBGA	289	126	7 X 18	150	315	135.9	7620	17.2	11.3	16.35

ZAV (S-PBGA-N289)

PLASTIC BALL GRID ARRAY

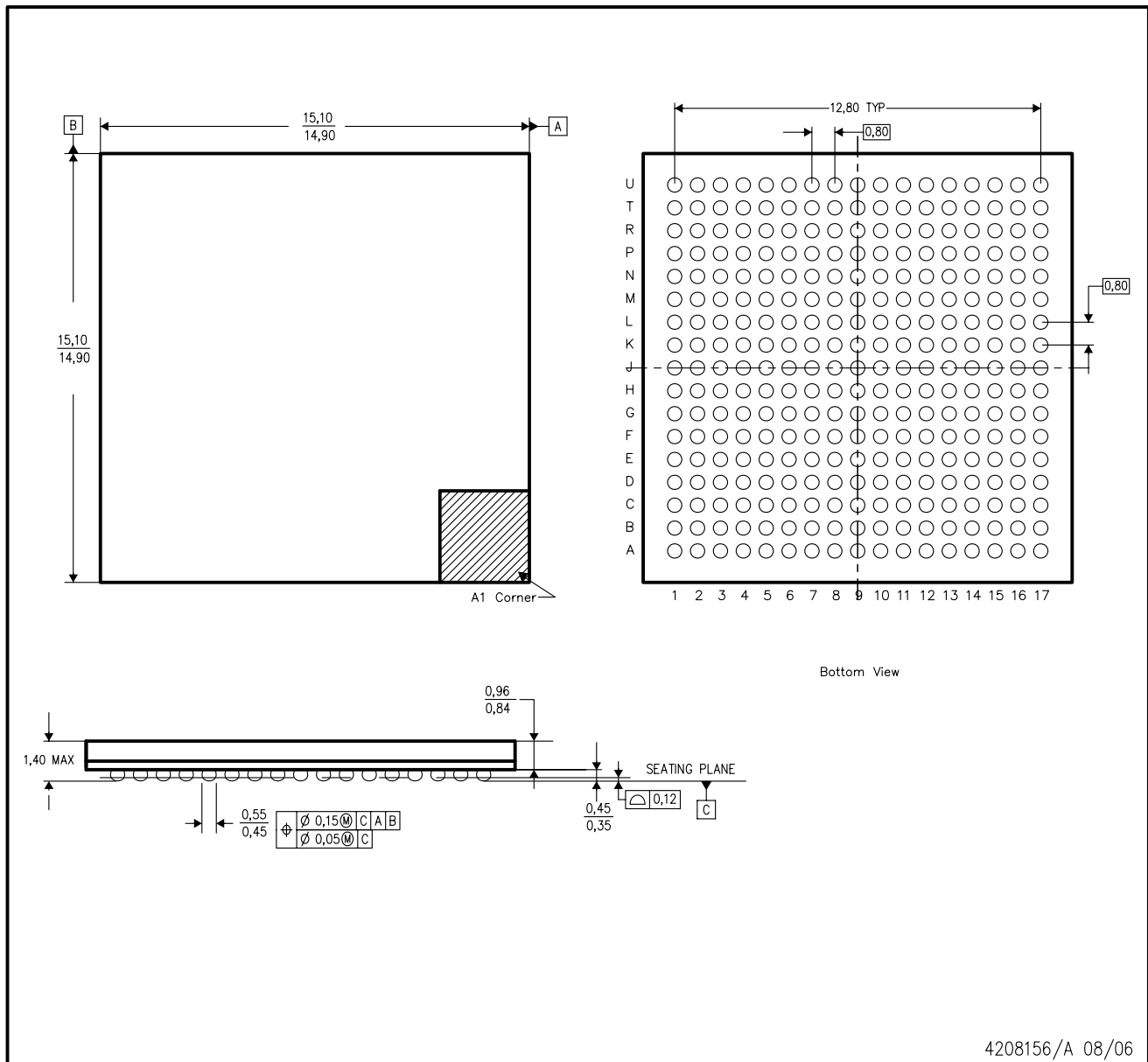

- NOTES:
- A. All linear dimensions are in millimeters.
 - B. This drawing is subject to change without notice.
 - C. This is a lead-free solder ball design.

IMPORTANT NOTICE AND DISCLAIMER

TI PROVIDES TECHNICAL AND RELIABILITY DATA (INCLUDING DATA SHEETS), DESIGN RESOURCES (INCLUDING REFERENCE DESIGNS), APPLICATION OR OTHER DESIGN ADVICE, WEB TOOLS, SAFETY INFORMATION, AND OTHER RESOURCES "AS IS" AND WITH ALL FAULTS, AND DISCLAIMS ALL WARRANTIES, EXPRESS AND IMPLIED, INCLUDING WITHOUT LIMITATION ANY IMPLIED WARRANTIES OF MERCHANTABILITY, FITNESS FOR A PARTICULAR PURPOSE OR NON-INFRINGEMENT OF THIRD PARTY INTELLECTUAL PROPERTY RIGHTS.

These resources are intended for skilled developers designing with TI products. You are solely responsible for (1) selecting the appropriate TI products for your application, (2) designing, validating and testing your application, and (3) ensuring your application meets applicable standards, and any other safety, security, regulatory or other requirements.

These resources are subject to change without notice. TI grants you permission to use these resources only for development of an application that uses the TI products described in the resource. Other reproduction and display of these resources is prohibited. No license is granted to any other TI intellectual property right or to any third party intellectual property right. TI disclaims responsibility for, and you will fully indemnify TI and its representatives against, any claims, damages, costs, losses, and liabilities arising out of your use of these resources.

TI's products are provided subject to [TI's Terms of Sale](#) or other applicable terms available either on ti.com or provided in conjunction with such TI products. TI's provision of these resources does not expand or otherwise alter TI's applicable warranties or warranty disclaimers for TI products.

TI objects to and rejects any additional or different terms you may have proposed.

Mailing Address: Texas Instruments, Post Office Box 655303, Dallas, Texas 75265
Copyright © 2022, Texas Instruments Incorporated